

ABB ACS180 Frequency Inverter Easy Start Guide



The ABB ACS180 Frequency Inverter range is available to order from inverterdrive.com

Step-by-step guidance for wiring, configuring and commissioning the ABB ACS180 Inverter, with parameter explanations, diagrams, and essential setup instructions.

This guide is designed to complement the official manufacturer manual and should not be used as a substitute for it.



This product is not a safety device. All safety considerations including but not limited to Emergency Stop provision should be assessed separately and are outside the scope of this guide.

Contents

Page 1	Contents
Page 2	Power and Motor Connections (Single Phase)
Page 3	Power and Motor Connections (Three Phase)
Page 4	Motor Connections - Star and Delta
Page 5	Parameters - Overview Parameters to Set Before Use
Page 6-7	How to Set a Parameter Value
Page 8	How to Operate from the Keypad
Page 9	How to Enable Sensorless Vector Mode
Page 10	How to Connect and Configure a Potentiometer for Remote Speed Control
Page 11	How to Connect and Configure a Run Forward or Run Reverse Switch
Page 12	How to Connect and Configure a Run/Stop Switch with Forward/Reverse Selection
Page 13	How to Configure 3-wire Control with Run and Stop Pushbuttons and a Forward Reverse Selection Switch
Page 14	Brake Resistor Connection
Page 15	STO (Safe Torque Off) Connections
Page 16	How to Reset the Inverter to Factory Defaults

1. Power and Motor Connections (Single Phase)



Before you begin, confirm that the inverter and all cables are completely isolated from the power supply, have been isolated for at least 5 minutes and that the motor is not turning.



Notes:

The illustration above is based on the 0.37kW rating (size R0). The terminals for other ratings are similarly labelled.

The supply voltage must match the Inverter specification.

Applying 400V to a 230V unit will cause damage to the Inverter.

Important:

The order of the three motor phases determines the initial direction the motor turns.

This can be reversed by swapping any two phases.

Use screened or armoured cable between the Inverter and motor and ensure it is grounded as shown.

Easy Start Guide

ABB ACS180 Frequency Inverter

2. Power and Motor Connections (Three Phase)



Before you begin, confirm that the inverter and all cables are completely isolated from the power supply, have been isolated for at least 5 minutes and that the motor is not turning.

POWER

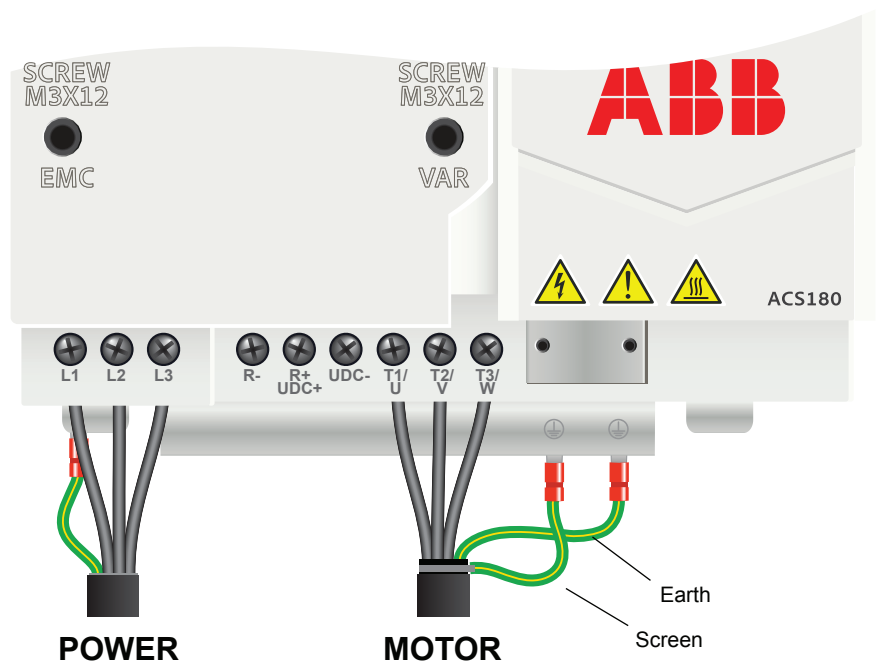

Notes:

The illustrations above are based on the 0.75kW 400V rating (size R0) and 15kW 400V rating (size R4).

The supply voltage must match the Inverter specification.

Applying 400V to a 230V unit will cause damage to the Inverter.

Important:

The order of the three motor phases determines the initial direction the motor turns.

This can be reversed by swapping any two phases.

Use screened or armoured cable between the Inverter and motor and ensure it is grounded as shown.

3. Motor Connections - Star and Delta

Dual voltage induction motors typically include terminal boxes with six points. The points can be connected together with links in one of two ways to suit one of the two rated voltages.

The two ways of connecting the links are shown below. These are known as 'Star' (the higher voltage) or 'Delta' (the lower voltage).

The selection of Star or Delta is not optional and must match the supply voltage.

Dual voltage motor name plates include symbols to represent voltage and full load current in each configuration.

Delta is represented by a triangle and Star by a Y (Wye).

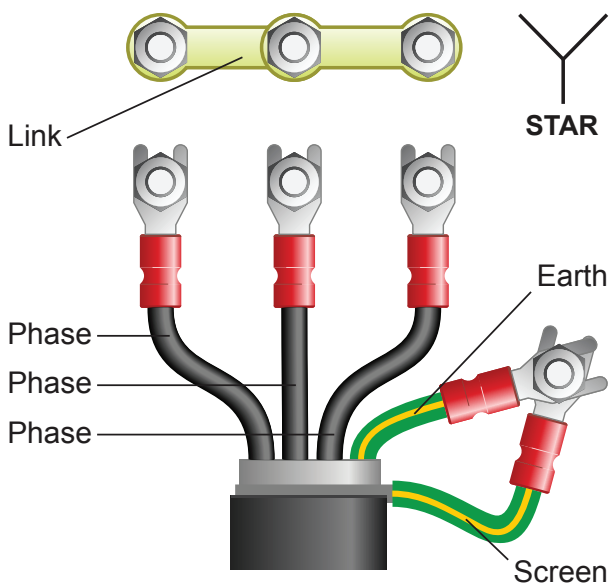

3.1 Motor Connected in STAR (or Wye):

For safety purposes, Star (shown opposite) is the default configuration for small motors (usually to 3kW) and is sometimes known as 'two at one side'.

Only two links are required for Star. Double-up the links if changing from Delta to allow the motor to be changed back in future.

The order of the three phases determines the direction the motor turns.

Note that the manufacturer recommends that the cable screen is earthed at both ends.

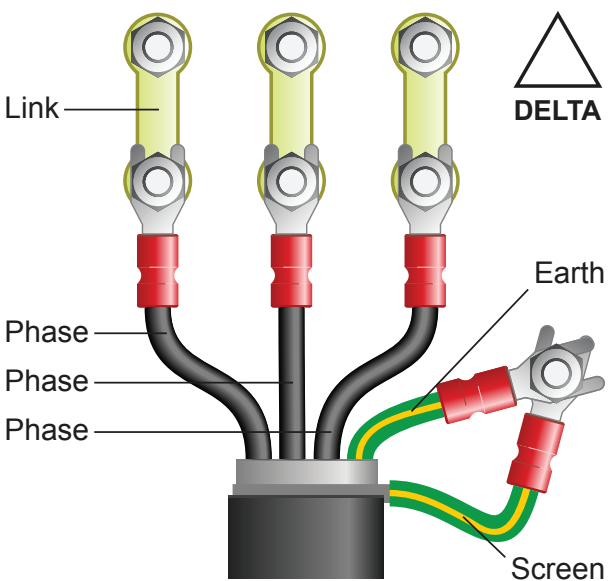

3.2 Motor Connected in DELTA:

The link configuration is shown in the illustration opposite and is sometimes referred to as 'three-a-breast'.

The order of the three phases determines the direction the motor turns.

Note that the manufacturer recommends that the cable screen is earthed at both ends.

4. Parameters - Overview

The Inverter contains a number of settings which can be changed to tailor it for use in a wide range of applications. These settings are known as parameters.

Parameters are typically referred to by code or number (e.g. 99.06 = Motor Current) with a description available in the manual.

The parameters contain critical information essential for correct operation of the

Inverter. Please see the recommendations below; Inverters that are not commissioned correctly may underperform or trip unexpectedly.

The parameters listed in section 5 are intended to provide a starting point for basic operation of the ACS180 AC Inverter.

The ACS180 product manual should be used for all other parameters.

5. Parameters to Set Before Use

Set the following parameters to allow the ACS180 to control a 50Hz induction motor in V/F control (scalar).

Further parameters are required to determine the speed and command reference, see sections 9, 10, 11 and 12.

See section 6 to learn how to set a parameter value

5.1 Parameters to Check and Values to Set

Parameter	Description	How to Set
21.03	Stop Mode	Default is 1, ramp to stop. Default will suit most applications. Set to 0 for coast to stop.
28.72	Acceleration Time (sec)	Default is 3 sec. Default will suit most applications. For fan loads longer may be required, eg 10 seconds.
28.73	Deceleration Time (sec)	Default is 3 sec. Default will suit most applications. For fan loads longer may be required, eg 10 seconds.
30.13	Minimum Frequency	Default is -50Hz. Change if required. If a minimum running speed is required set to 20Hz, for example. This parameter only applies when the motor control mode is set to scalar (see 99.04 below).
30.14	Maximum Frequency	Default is 50Hz. Change if required. This parameter only applies when the motor control mode is set to scalar (see 99.04 below).
97.01	Switching Frequency (kHz)	Default is 4kHz. Default will suit most applications. Increase to reduce motor noise but with caution as this will de-rate the unit.
97.20	V/F Ratio (U/F)	Default is 0, linear. Default will suit many applications. For fan and pump loads set to 1, squared.
99.03	Motor Type	Default is 0 for standard AC induction motor (asynchronous). Set to match motor type.
99.04	Motor Control Mode	Default is 1, V/F (Scalar). Default will suit many applications. See section 8 for sensorless vector control for high starting torque applications.
99.06	Motor Current (A)	Default is rating dependant. Set to value on the motor nameplate.
99.07	Motor Voltage (V)	Default is rating dependant. Set to value on the motor nameplate.
99.09	Motor Frequency (rpm)	Default is rating dependant. Set to value on the motor nameplate.
99.11	Motor Power Factor	Default is 0. Set to value on the motor nameplate if specified.

6. How to Set a Parameter Value



6.1 Home Screen

Press the “Back” button repeatedly until the “Home Screen” (speed display) is visible as shown.

Press the “OK” button to open the main menu: ≡

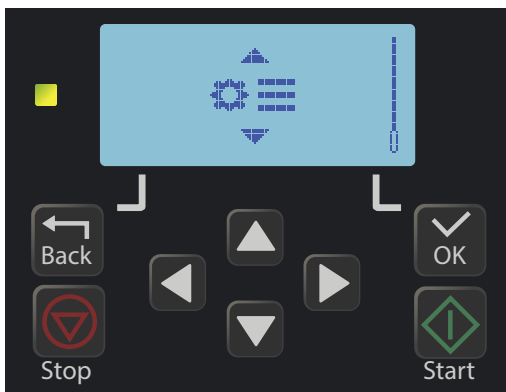

6.2 Main Menu Items

Use the ▲ and ▼ keys to scroll through the 5 submenus:



... Motor Data ... Motor Control ... Control Macros ... Diagnostics ... Parameters ...

In this example we will set parameter 99.06, motor current.

Select the parameters submenu as shown and press the “OK” button.

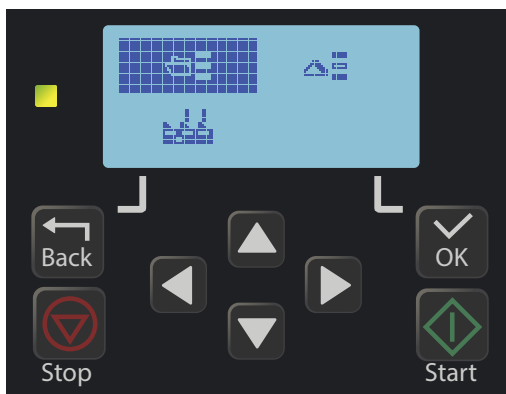

6.3 Select Complete Parameter List

Use the ▲ and ▼ and ◀ and ▶ keys to select the complete parameter list as shown and press the “OK” button.



6.4 Selecting the Parameter List

Use the ▲ and ▼ keys to select a parameter group.

For parameter 99.06 select 99 and press the “OK” button.

6. How to Set a Parameter Value (continued)

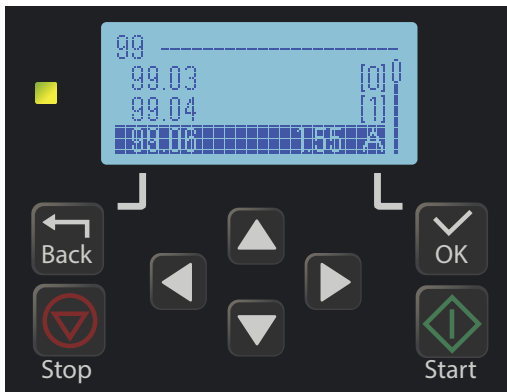

6.5 Selecting a Specific Parameter

The currently selected parameter group is indicated in the top left corner of the display.

Use the ▲ and ▼ keys to highlight parameter 99.06 (motor current).

Note: Without accessing the parameter you can see its value, in this instance 1.55A.

Press the “OK” button to edit the parameter value.



6.6 Changing a Parameter

Use the ◀ and ▶ keys to highlight the digit you need to change.

Use the ▲ and ▼ keys to change the value.

In this example, we have changed the value to 1.42A.

Press the “OK” button to save the changes.

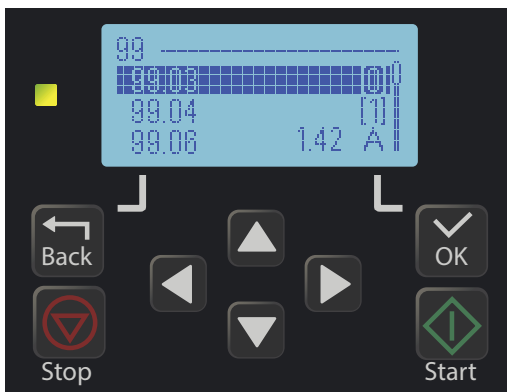

6.7 Parameter Change Complete

The parameter value is now saved and is visible in the parameter list as shown.

Press the “Back” button to return to the parameter group list or press the “Back” button repeatedly to return to the “Home Screen” (as indicated in section 6.1).

7. How to Operate the Inverter from the Keypad

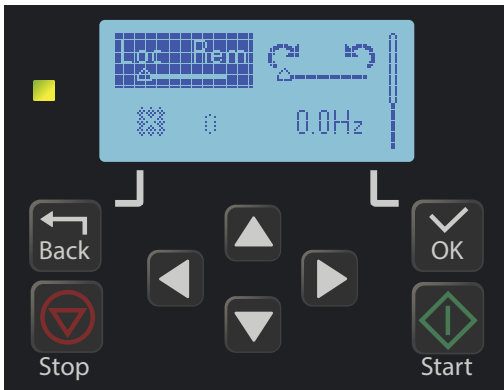

7.1 Select “Local” Control Mode

Press the “Back” button repeatedly until the “Loc Rem” option is visible.

Then, press the “OK” button to toggle between “Local” and “Remote” control.

Ensure that “Local” control is selected as shown.



7.2 Set the Speed Reference

Press the “Back” button repeatedly until the “Home Screen” (speed display) is visible. The display will show “Loc” on the top-left when in “Local” control and “Rem” when in “Remote” control.

Use the ▲ and ▼ keys to set the local speed reference as required. A negative value will change direction. In this example, we have set the speed reference to 40.0Hz.

The speed reference can be seen on the top right as shown.



7.3 Press the Green “Start” Button to Start the Motor.

Press the green “Start” button. The motor will accelerate to the speed reference.

The output speed is indicated in the centre of the display. The arrow icons rotate to indicate that the motor is running.

Whilst running, the speed reference can be changed using the ▲ and ▼ keys. The arrow icons will become dotted when the motor is accelerating or decelerating.



7.4 Press the Red “Stop” Button to Stop the Motor.

Press the red “Stop” button to stop the motor.

Whilst the motor is decelerating the output speed in the centre of the display will reduce to zero.

The arrow icons rotate until the motor has stopped.

Note: The local speed reference value is stored and will be retained after a power cycle.

8. How to Enable Sensorless Vector Mode

The standard operating mode for the ACS180 range is V/F. This is the simplest form of operation and controls volts and frequency to vary the speed of a standard induction motor.

The ACS180 range can also be operated in Sensorless Vector Mode. This can improve the motor performance without requiring a separate feedback device.

In order to improve performance, sensorless vector requires a number of values to build a 'model' of the motor it is controlling. These are described below.

Note: Sensorless vector control is not suitable where the motor rating is significantly less than the Inverter rating or where more than one motor is being controlled from a single Inverter.

8.1 Parameters to Set for a Constant Torque (heavy duty) Load

Parameter	Description	How to Set
23.12	Acceleration Time (sec)	Default is 3 sec. Change if required. This parameter only applies when the motor control mode is set to vector (see 99.04 below).
23.13	Deceleration Time (sec)	Default is 3 sec. Change if required. This parameter only applies when the motor control mode is set to vector (see 99.04 below).
99.04	Motor Control Mode	Default is 1, scalar, set to 0 vector for sensorless vector control.
99.13	ID Run Request	Default is 3 standstill. Default required in this instance. The parameter resets to 0 once auto-tune (ID Run) is complete.

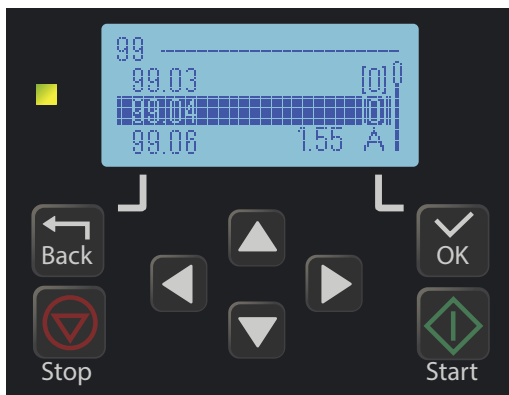

8.2 Sensorless Vector Setup

⚠ **Reset to factory defaults as detailed in section 15. This is only required at initial set up and will reset all parameters** ⚠

Set motor parameters as detailed in section 5. Select local control (Loc) as detailed in section 7.

Set parameter 99.04 to 0 for vector control. An AFF6 warning will appear which can be ignored.

Press "Back" continuously until you can see the "Home Screen". Note that the speed references are now in rpm.



8.3 The Auto-tune Process

Press "Start" on the keypad. The ACS180 starts the auto-tune (ID Run). The direction arrow will move clockwise but the motor will not turn (standstill auto-tune).

The green indicator will flash until complete. When the indicator stops flashing the auto-tune is complete.

Note: You must ensure the motor is loaded (not bare shaft) when operated in vector control otherwise it will trip overspeed (7310).

9. How to Connect and Configure a Potentiometer for Remote Speed Control

If speed control via the integrated keypad is unsuitable for the application, a remote potentiometer can be used instead.

This provides the benefit of allowing motor speed to be controlled from a more convenient location such as a cabinet door or on the machine itself. Any potentiometer from 1kΩ to 10kΩ can be used.

9.1 Parameters to set

Parameter	Description	How to Set
28.11	Frequency Reference (EXT1)	Default is 1, analogue input 1. Set to 2, analogue input 2.
12.25	AI2 Unit Selection	Default is 10 for mA. Set to 2 for volts.
30.13	Minimum Frequency	Default is -50Hz. Default will suit many applications. If a minimum running speed is required set to 20Hz, for example.
30.14	Maximum Frequency	Default is 50Hz. Default will suit many applications. Change if required.

9.2 Connecting the Potentiometer

To use a potentiometer with the ACS180, the drive must be set to “Remote” control mode: press the “Back” button repeatedly until the display shows “Loc Rem”, then press “OK” if “Rem” is not already selected.

A wiring diagram is shown opposite. The most important connection is the centre terminal or ‘wiper’. The wiper will output a variable voltage between 0 and 10V and should be connected to AI2 (15) on the Inverter. It is this voltage which provides the speed signal with 0V being the slowest and 10V the fastest.

If the rotation of the potentiometer is the opposite to that required, reverse connections AGND (16) and 10V (23).

Use shielded cable between the potentiometer and Inverter.

The default minimum output frequency is 0Hz when AI2 is 0V and is determined by parameter 30.13.

The default maximum output frequency is 50Hz when AI2 is 10V and is determined by parameter 30.14.

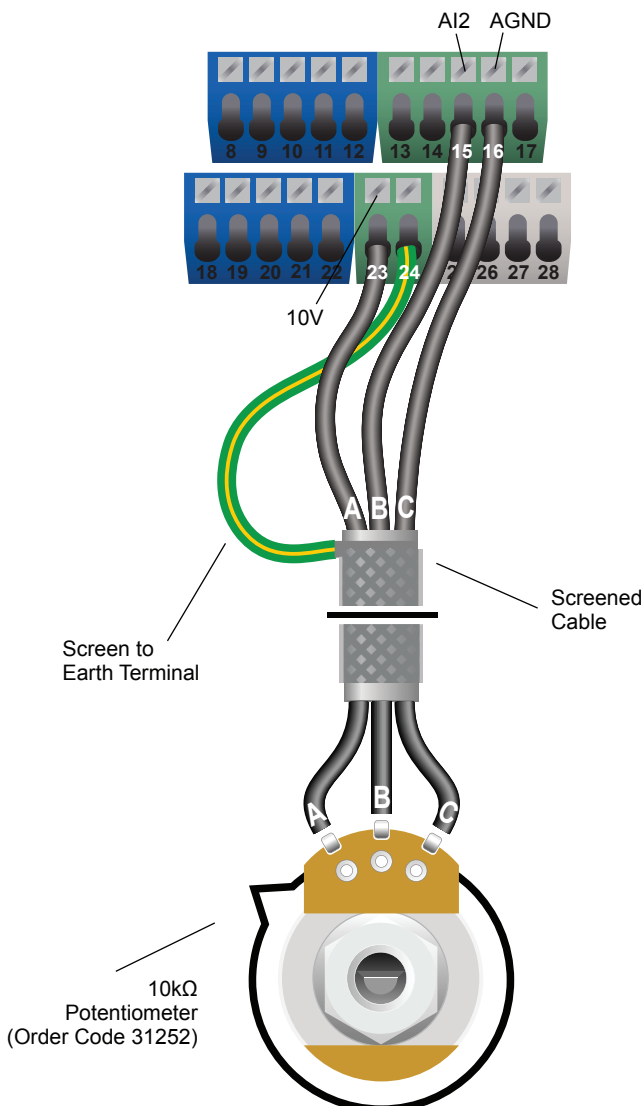

10. How to Connect and Configure a Run Forward or Run Reverse Switch

The procedure described in section 7 enables run stop operation via the inverter keypad.

If this is unsuitable for the application, a remote switch can be used instead.

10.1 Parameters to set for Remote Run/Stop

Parameter	Description	How to Set
20.01	External Commands (EXT1)	Default is 2, run/stop with rev select. Set to 3, run fwd and run rev.
30.13	Minimum Frequency	Default is -50Hz. Set to required speed reference value, eg 20Hz.

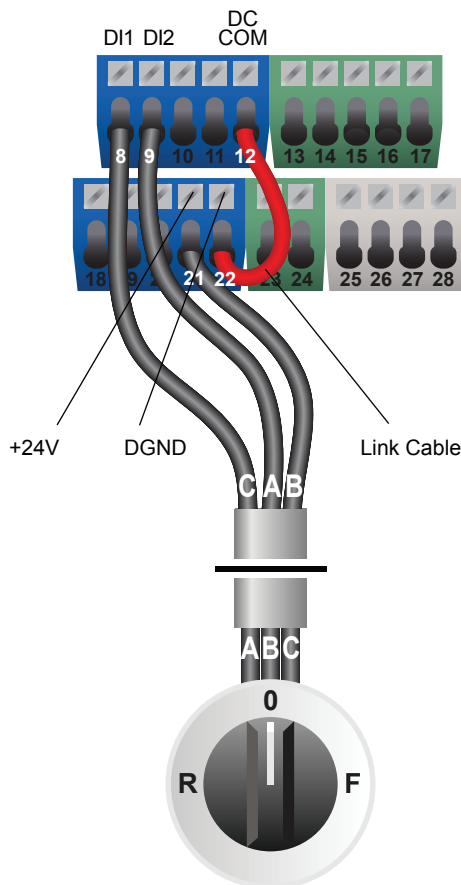

Switch, 3 Position Normally Open 'Run Forward / Stop / Run Reverse'
Order Code 32901

10.2 Connecting the Switch

To use the terminals on the ACS180, the drive must be set to "Remote" control mode: press the "Back" button repeatedly until the display shows "Loc Rem", then press "OK" if "Rem" is not already selected.

A wiring diagram is shown in the illustration opposite. Terminal 21 (+24V) is the positive logic (PNP) for digital inputs 8 (DI1) and 9 (DI2).

A suitable 3 position 'normally open' switch should be installed between terminal 21 (+24V) and terminals 8 (DI1) and 9 (DI2). The centre position should remain open circuit.

When a connection is made between terminals 8 (DI1) and 21 (+24V), the motor will run forward. When terminals 9 (DI2) and 21 (+24V) are connected the motor will run in reverse.

The motor speed is determined by parameter 30.13.

Note: The red link cable shown opposite is required, or the switch will not operate.

11. How to Connect and Configure a Run/Stop Switch with Forward/Reverse Selection

The procedure described in section 7 enables run stop operation via the inverter keypad.

If this is unsuitable for the application, a remote switch can be used instead.

This section explains how to enable 2-wire control with run/stop and forward/reverse commands via individual selector switches.

The direction switch can be omitted if the motor will always run forward.

11.1 Parameters to set for Remote Run/Stop

Parameter	Description	How to Set
20.01	External Commands (EXT1)	Default is 2, run/stop with rev select. Set to 2, default required in this instance.
30.13	Minimum Frequency	Default is -50Hz. Set to required speed reference value, eg 20Hz.

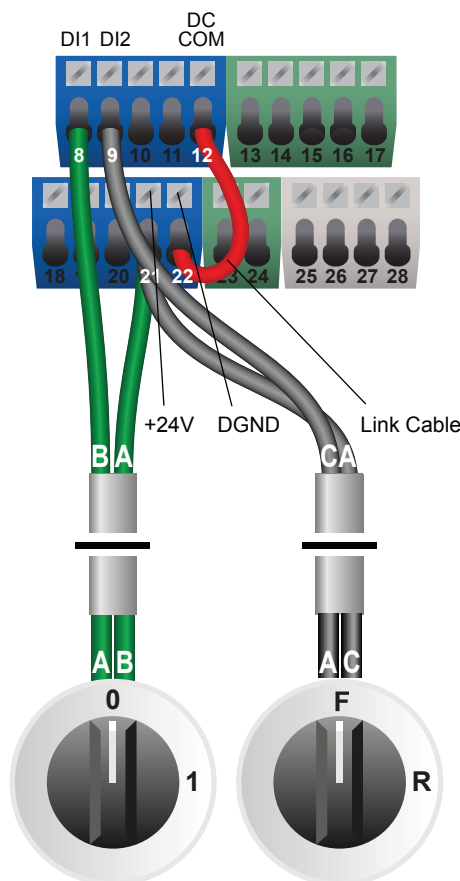

Switch, 2 Position Normally Open 'Run/Stop' Order Code 32900
 Switch, 2 Position Normally Open 'Forward/Reverse' Order Code 32900

11.2 Connecting the Switch

To use the terminals on the ACS180, the drive must be set to "Remote" control mode: press the "Back" button repeatedly until the display shows "Loc Rem", then press "OK" if "Rem" is not already selected.

A wiring diagram is shown in the illustration opposite. Terminal 21 (+24V) is the positive logic (PNP) for Digital Inputs 8 (DI1) and 9 (DI2).

Two suitable 2 position 'normally open' switches should be installed between 21 (+24V) and terminals 8 (DI1) and 9 (DI2).

When a connection is made between terminals 8 (DI1) and 21 (+24V), the motor will run, when the connection opens the motor will stop. When terminals 9 (DI2) and 21 (+24V) are connected the reverse direction is selected.

The motor speed is determined by parameter 30.13.

The forward/reverse switch only selects the direction of rotation; it will not start or stop the motor.

Note: The red link cable shown opposite is required, or the switch will not operate.

12. How to Configure 3-Wire Control with Run and Stop Pushbuttons and a Forward Reverse Selection Switch

The procedure described in section 7 enables run stop operation via the Inverter keypad. If this is unsuitable for the application, remote switches can be used instead.

This section explains how to enable 3-wire control with run, stop and forward/reverse commands using two pushbuttons and a selector switch.

If reverse control is not required the direction selector switch can be omitted.

12.1 Parameters to set for Remote Run/Stop

Parameter	Description	How to Set
20.01	External Command (EXT1)	Default is 2 run/stop with rev select, Set to 5 for 3-wire control.
20.05	Ext1 in3 Source	Default is 0, Always off. Set to 4, to assign DI3 for direction selection.
22.22	Constant Speed Sel1	Default is 4, DI3. Set to 5 to allow DI3 to be reassigned.
28.22	Constant Frequency Sel1	Default is 4, DI3. Set to 5 to allow DI3 to be reassigned.
30.13	Minimum Frequency	Default is -50Hz. Set to a positive value eg 10Hz.

Alternatively, 3-wire control can be enabled using Macro 11 (parameter 96.04)

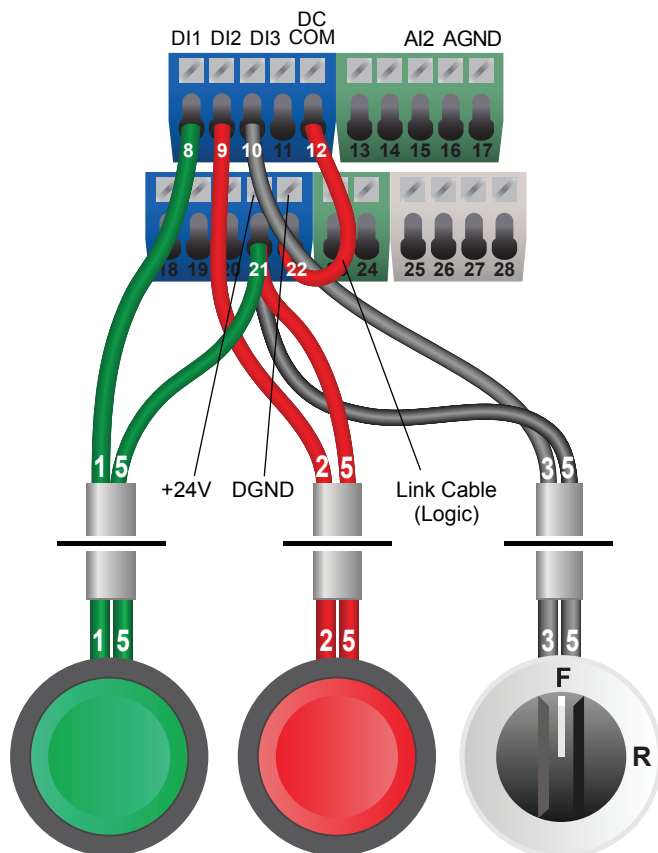

Pushbutton Normally Open 'Run' Order Code 32896
 Pushbutton Normally Closed 'Stop' Order Code 32895
 Switch, 2 Position Normally Open 'Forward/Reverse' Order Code 32902

12.2 Connecting the Switches

To use the terminals on the ACS180, the drive must be set to "Remote" control mode: press the "Back" button repeatedly until the display shows "Loc Rem", then press "OK" if "Rem" is not already selected.

For 'run' and 'stop' two suitable pushbuttons should be installed between terminals 8 (DI1) and 21 (+24V) for the 'run' command and terminals and 9 (DI2) and 21 (+24V) for the 'stop' command. The 'run' contact should be 'normally open' and the 'stop' contact should be 'normally closed'.

One suitable 2 position 'normally open' switch should be installed between terminals 10 (DI3) and 21 (+24V) for direction selection.

A momentary connection between 8 (DI1) and 21 (+24V) will start the motor. It will continue to run until the connection between 9 (DI2) and 21 (+24V) is broken. Direction can be reversed by closing the connection between 10 (DI3) and 21 (+24V).

Note: The red link cable shown opposite is required, or the switch will not operate.

13. Brake Resistor Connection



Before you begin, confirm that the inverter and all cables are completely isolated from the power supply, have been isolated for at least 5 minutes and that the motor is not turning.

By default, the ACS180 automatically extends the deceleration time if it cannot slow a high inertia load within the specified time.

For applications that require faster stopping, dynamic braking can be used to maintain or reduce the deceleration time by safely absorbing the excess energy generated during braking.

This requires the addition of a braking resistor, which dissipates the regenerated energy as heat. The resistor must be correctly sized to suit both the inverter and the application.

In addition, the ACS180 must be configured to disable voltage monitoring to enable the braking resistor. If voltage monitoring is disabled without a resistor connected, the drive may trip with **fault code 3210**.

13.1 Parameters to set for Dynamic Braking

Parameter	Description	How to Set
30.30	Overtoltage Control	Default is 1, enabled. Set to 0, disabled. Do not disable unless the drive is fitted with a suitable braking resistor.

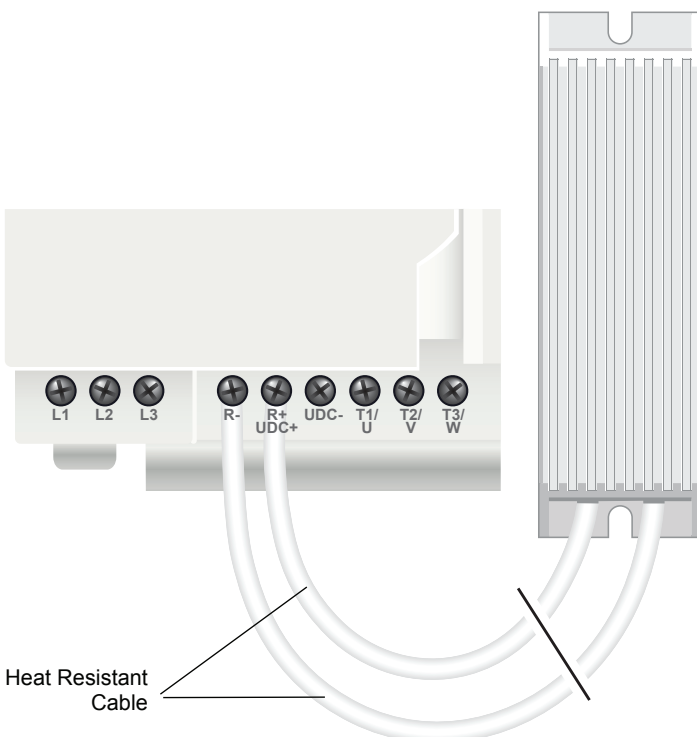

13.2 Connecting the Resistor

A wiring diagram is shown in the illustration opposite. Connect the brake resistor to the R+UDC+ and R- terminals on the Inverter. The order of the connections is unimportant.

The brake resistor may get hot in operation. Ensure that it is mounted in a suitable position at least 10cm away from other items.

It is essential that a resistor of the correct rating is used. Consult the manufacturer's manual or product listing at inverterdrive.com for further information.

Dynamic braking is only available for frame size R2 and above.

14. STO (Safe Torque Off) Connections



This section is an overview only. You must also refer to the manual provided by the manufacturer for full details of STO functionality.

Safe Torque Off (STO) is a feature that is included on all ACS180 products.

STO provides a facility to disable the output of the Inverter so that the motor it is controlling cannot be operated ie. that no torque can be applied. However, it does not provide any form of braking so will not prevent the load from rotating the motor.

The STO function is only effective when wired to suitable safety devices that detect an 'unsafe' situation. A safety assessment of the machinery is required by suitably qualified personnel to identify what should be considered unsafe and what safety devices are appropriate for the application.

It is not recommended to stop a motor using the Inverter STO function. The motor should be stopped before the STO feature is activated.

STO does not isolate the electrical supply. Therefore the Inverter must be isolated from the supply before any maintenance is carried out.

14.1 STO Links

The ACS180 is supplied with links configured so that the Inverter can be used with the STO disabled. The 'STO Disabled' illustration shows this arrangement.

If the STO is to be used, remove the links and insert a suitable safety circuit.

STO Disabled

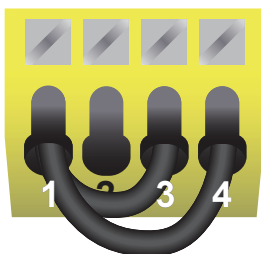

STO Enabled

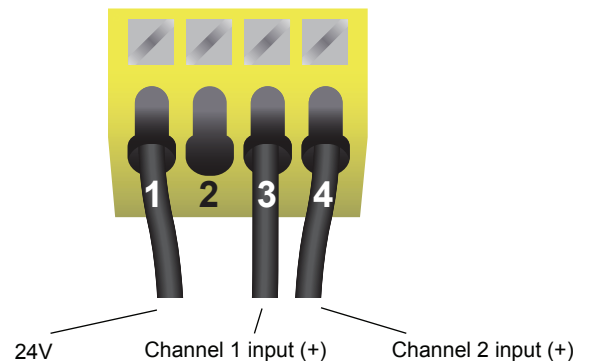

14.2 Keypad

When a dual channel safety device is wired to the Inverter and both channels are closed (safe) the Inverter can be operated as normal.

If one or both of the channels open the Inverter will indicate an STO fault and cannot be operated. When the safety circuit changes to closed (safe) the ACS180 can be reset by pressing OK.



15. How to Reset the Inverter to Factory Defaults

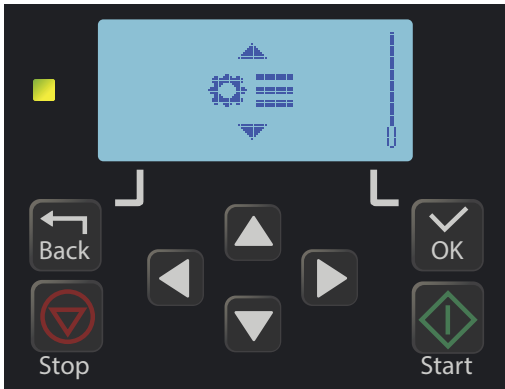

15.1 Access the Parameter List

Press the “Back” button repeatedly until the “Home Screen” is visible (as shown in section 15.4).

Press the “OK” button to access the main menu: ☰

Use the ▼ key until the parameter icon is displayed (as shown on the left).

Press the “OK” button to select the parameter sub group.

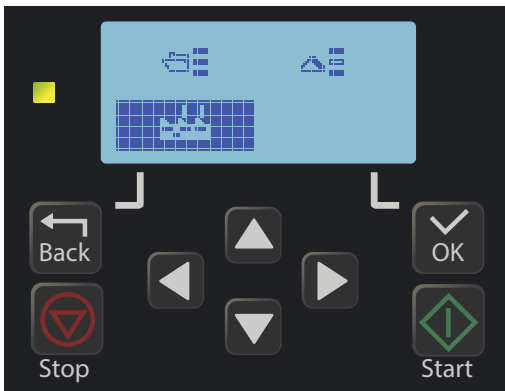

15.2 Select Factory Reset

Use the ▼ key to select the factory icon.

Press the “OK” button to select factory reset.

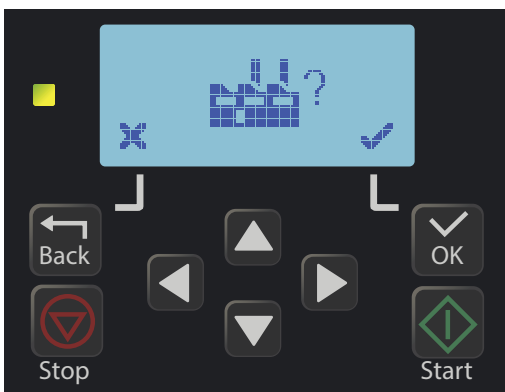

15.3 Confirm Factory Reset

There are 2 options ✓ (OK) or ✕ (back / cancel).

Press the “OK” button to start the factory reset.

During the process the display will go blank briefly and you will hear the internal relay switch off and on.



15.4 The Inverter Resets

When complete, the “Home Screen” will appear as shown on the left.

Note: All parameters will be reset including the motor parameters.