

Delta MS300 Frequency Inverter Easy Start Guide



The Delta MS300 Frequency Inverter range is available to order from inverterdrive.com

This guide is intended to complement the user manual provided by the manufacturer. It is provided as a basic introduction to the product for Inverter Drive Supermarket customers. It should not be used as a replacement for the manual issued by the manufacturer.



This product is not a safety device. All safety considerations including but not limited to Emergency Stop provision should be assessed separately and are outside the scope of this guide.

Contents

Page 1	Contents
Page 2	Power and Motor Connections (Single Phase)
Page 3	Power and Motor Connections (Three Phase)
Page 4	Motor Connections - Star and Delta
Page 5	Parameters - Overview Parameters to be Set Before Use
Page 6	How to Set a Parameter Value
Page 7	How to Operate the Inverter from the Keypad
Page 8	How to Enable Sensorless Vector Mode
Page 9	How to Connect and Configure a Potentiometer for Remote Speed Control
Page 10	How to Connect and Configure a Run Forward or Run Reverse Switch
Page 11	How to Connect and Configure a Run/Stop Switch with Forward/Reverse Selection
Page 12	How to Configure 3-Wire Control with Run and Stop Pushbuttons and a Forward Reverse Selection Switch
Page 13	Brake Resistor Connection
Page 14	STO (Safe Torque Off) Connections
Page 15	How to Reset the Inverter to Factory Defaults

1. Power and Motor Connections (Single Phase)



Before you begin, confirm that the inverter and all cables are completely isolated from the power supply, have been isolated for at least 5 minutes and that the motor is not turning.

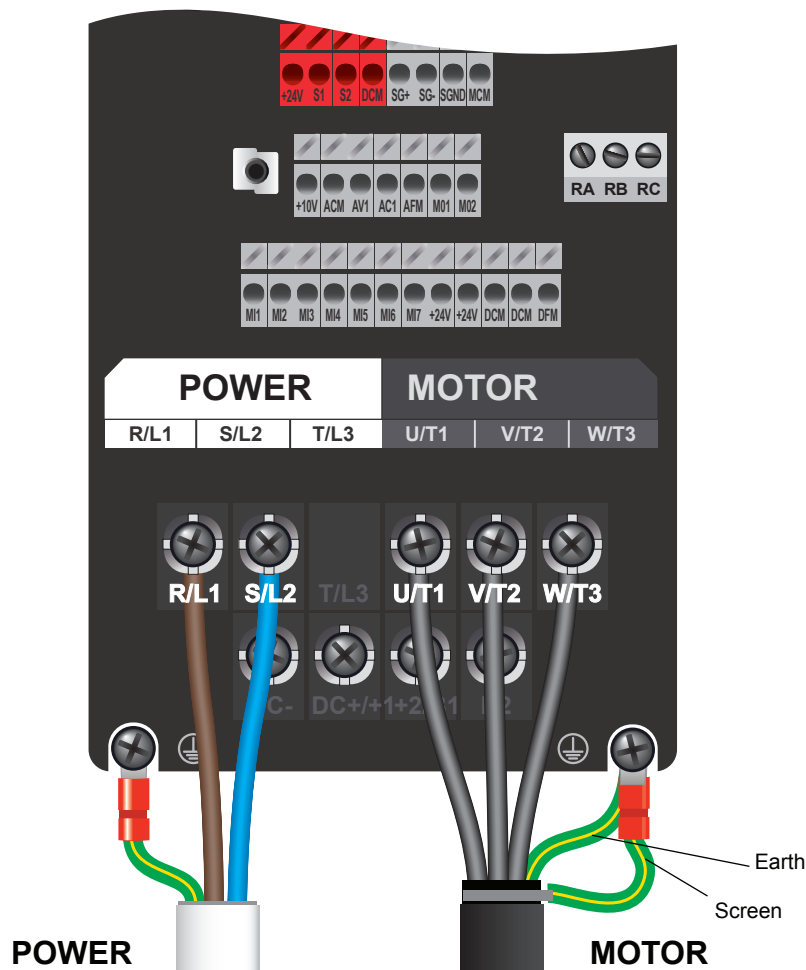

Notes:

The illustration above is based on the 2.2kW rating (size C). The terminals for other ratings are similarly labelled.

The supply voltage must match the Inverter specification.

Applying 400V to a 230V unit will cause damage to the Inverter.

Important:

The order of the three motor phases determines the initial direction the motor turns.

This can be reversed by swapping any two phases or changing the Inverter parameters.

Use screened or armoured cable between the Inverter and motor and ensure it is grounded as shown.

2. Power and Motor Connections (Three Phase)



Before you begin, confirm that the inverter and all cables are completely isolated from the power supply, have been isolated for at least 5 minutes and that the motor is not turning.

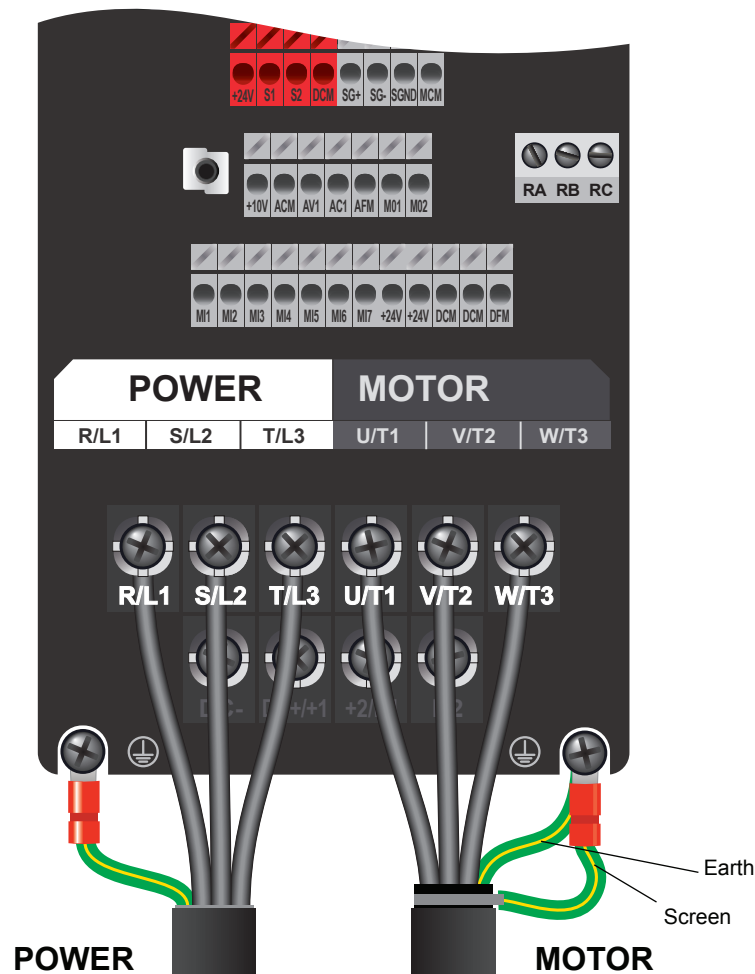

Notes:

The illustration above is based on the 2.2kW rating (size C).

The supply must match the Inverter specification.

Applying 400V to a 230V unit will cause damage to the Inverter.

Important:

The order of the three motor phases determines the initial direction the motor turns.

This can be reversed by swapping any two phases or changing the Inverter parameters.

Use screened or armoured cable between the Inverter and motor and ensure it is grounded as shown.

3. Motor Connections - Star and Delta

Dual voltage induction motors typically include terminal boxes with six points. The points can be connected together with links in one of two ways to suit one of the two rated voltages.

The two ways of connecting the links are shown below. These are known as 'Star' (the higher voltage) or 'Delta' (the lower voltage).

The selection of Star or Delta is not optional and must match the supply voltage.

Dual voltage motor name plates include symbols to represent voltage and full load current in each configuration.

Delta is represented by a triangle and Star by a Y (Wye).

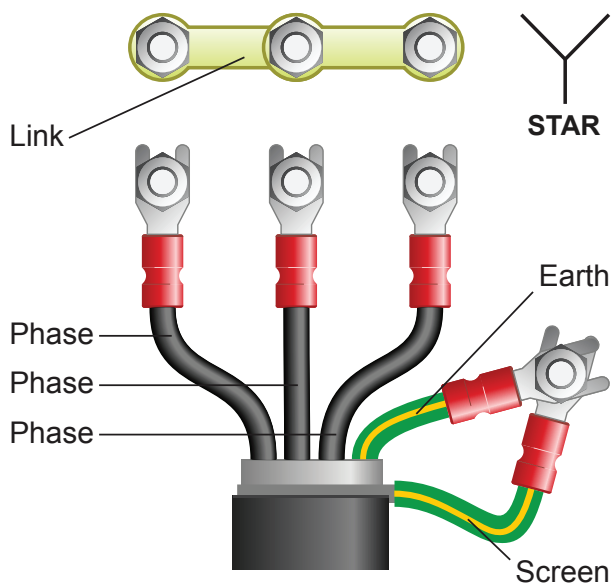

3.1 Motor Connected in STAR (or Wye):

For safety purposes, Star (shown opposite) is the default configuration for small motors (usually to 3kW) and is sometimes known as 'two at one side'.

Only two links are required for Star. Double-up the links if changing from Delta to allow the motor to be changed back in future.

The order of the three phases determines the direction the motor turns.

Note that the manufacturer recommends that the cable screen is earthed at both ends.

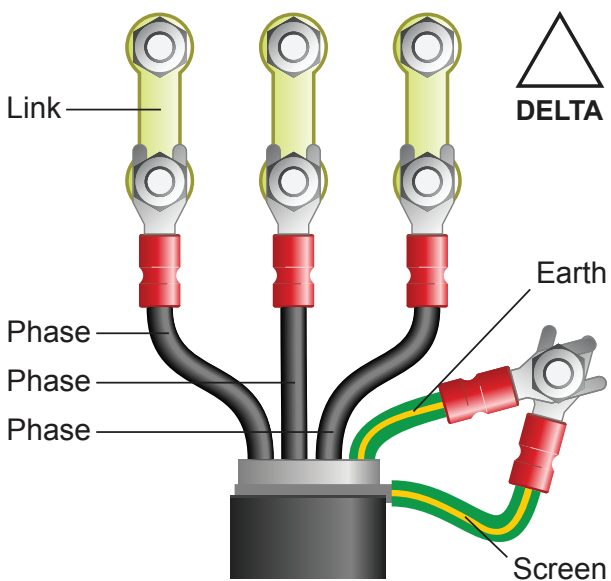

3.2 Motor Connected in DELTA:

The link configuration is shown in the illustration opposite and is sometimes referred to as 'three-a-breast'.

The order of the three phases determines the direction the motor turns.

Note that the manufacturer recommends that the cable screen is earthed at both ends.

4. Parameters - Overview

The Inverter contains a number of settings which can be changed to tailor it for use in a wide range of applications. These settings are known as parameters.

Parameters are typically referred to by code or number (e.g. 05.01 = motor full load current) with a description available in the manual.

The parameters contain critical information essential for correct operation of the Inverter. Please see the recommendations below; Inverters that are not commissioned correctly may underperform or trip unexpectedly.

The parameters listed in section 5 are intended to provide a starting point for basic operation of the MS300 Inverter. The MS300 product manual should be used for all other parameters.

5. Parameters to Set Before Use

Set the following parameters to allow the MS300 to control a 50Hz induction motor in V/F control.

Further parameters are required to determine the speed and command reference, see sections 9, 10, 11 and 12.

See section 6 to learn how to set a parameter value

5.1 Parameters to Check and Values to Set

Parameter	Description	How to Set
00.02	Parameter Reset	Default is 0, not active. Set to 9 for default values for 50Hz operation. △ This is only required at initial set up and will reset <u>all</u> parameters △
00.11	Speed Control Mode	Default is 0, V/F control. Default will suit most applications. See page 8 for sensorless vector control for high torque applications.
00.16	Load Selection	Default is 1, heavy duty load. Default is suitable for constant torque loads. For variable torque (fan type) loads set this value to 0.
00.17	Carrier Frequency (kHz)	Default is 4kHz. Default is suitable for most applications. Increase to reduce motor noise but with caution as this may de-rate the unit.
00.22	Stop Method	Default is 0, ramp to stop. Default is suitable for many applications. Set to 1 for coast to stop.
01.00	Maximum Frequency (Hz)	Default is 50Hz (00.02 reset). Default is suitable for many applications.
01.01	Base Frequency (Hz)	Default is 50Hz (00.02 reset). Motor frequency. Set to value on motor nameplate.
01.02	Base Voltage (V)	Default is product dependant. Normally the same voltage as the supply eg. 230V or 400V.
01.11	Lower Limit Output Freq (Hz)	Default is 0.5Hz. Default is suitable for many applications.
01.12	Acceleration Time 1 (sec)	Default is 10s. Default is suitable for many applications.
01.13	Deceleration Time 1 (sec)	Default is 10s. Default is suitable for many applications.
05.01	Motor Full Load Current (A)	Default is product dependant. Set to value on motor nameplate.
05.02	Motor Rated Power (kW)	Default is product dependant. Set to value on motor nameplate.
05.03	Motor Rated Speed (rpm)	Default is 1410 rpm or 1710 rpm. Set to value on motor nameplate.
05.04	Number of Motor Poles	Default is 4. Set to match motor. Eg. 4 pole motor rpm is around 1450rpm; 2 pole motor is around 2800 rpm.

6. How to Set a Parameter Value



6.1 Find Parameter Groups

This example demonstrates the steps required to set parameter `05.01` motor full load current in amps.

With the motor stopped and any fault or alarm messages cleared press the MODE key three times, then the ENTER key once to access the parameter list.

The display will show parameter group `00` or the last parameter group changed.



6.2 Find a Parameter Group eg. 05

There are a total of 15 parameter groups:



Use the ▲ and ▼ keys to cycle through the parameter groups.

Find parameter group `05` and press ENTER to select.



6.3 Find a Parameter eg. 05.01

The display will show `05.00` to indicate parameter `00` within group `05`.

Use the ▲ and ▼ keys to navigate to parameter `05.01`.

Press ENTER to select.



6.4 Change a Parameter Value

Use the ▲ and ▼ keys to increase or decrease the value. In this example we have set the value to `1.74` A which is the rated current of our motor.

Press ENTER to save the changes. 'End' will show briefly before returning to the selected parameter.

Use the arrow keys to find another parameter in the same group or press MODE to return to the parameter group or press MODE twice to return to the top menu.

7. How to Operate the Inverter from the Keypad



7.1 Select Local Control

As default the MS300 is set for keypad control.

To confirm that keypad control is active, check that the value of parameters `00.20` and `00.21` are both set to 0.

In keypad control there are 2 ways to set the speed reference; the keypad arrow keys or the keypad mounted potentiometer.



7.2 Setting the Speed Reference with the ▲ and ▼ keys

When `00.20` is set to 0 the speed is changed using the keypad keys. Also, parameter `00.21` should be set to 0 for keypad control.

Before attempting to set the speed reference, press the MODE key repeatedly until the speed reference (prefixed with F) is displayed.

Use the ▲ and ▼ keys to set the speed reference to `35.00`.



7.3 Selecting the Speed Reference with the Front Mounted Potentiometer

When `00.20` is set to 7 the speed is changed using the front mounted potentiometer. Also, parameter `00.21` should be set to 0 for keypad control.

As before, press the MODE key repeatedly until the speed reference (prefixed with F) is displayed.

Use the potentiometer to set the speed reference as required, for example `41.09`, as shown.



7.4 Start and Stop the Motor

Press the green RUN key to start the motor.
Press the red STOP key to stop the motor.

When running the 'run' indicator will show on the keypad.

During deceleration the 'run' indicator will flash until stopped.

Note: The keypad speed reference is stored, so it will be remembered after the Inverter is powered off.

8. How to Enable Sensorless Vector Mode

The standard operating mode for the MS300 is V/F. This is the simplest form of operation and controls volts and frequency to vary the speed of a standard induction motor.

The MS300 can also be operated in Sensorless Vector Mode. This can improve the motor performance without requiring a separate feedback device.

In order to improve performance, sensorless vector requires a number of values to build a 'model' of the motor it is controlling. These are described below.

Note: Sensorless vector control is not suitable where the motor rating is significantly less than the Inverter rating or where more than one motor is being controlled from a single Inverter.

8.1 Parameters to Check and Values to Set for a Constant Torque (heavy duty) Load

Parameter	Description	How to Set
00.02	Parameter Reset	Default is 0, not active. Set to 9 for default values for 50Hz operation. ⚠ This is only required at initial set up and will reset <u>all</u> parameters ⚠
00.11	Speed Control Mode	Default is 0, V/F control. Set to 5 for sensorless vector control.
01.01	Base Frequency (Hz)	Default is 50Hz. Set to value on motor nameplate.
01.02	Base Voltage (V)	Default is product dependant. Set to value on motor nameplate. Normally the same voltage as the supply eg 230V or 400V.
05.01	Motor Full Load Current (A)	Default is product dependant. Set to value on motor nameplate.
05.02	Motor Rated Power (kW)	Default is product dependant. Set to value on motor nameplate.
05.03	Motor Rated Speed (rpm)	Default is 1410 rpm or 1710 rpm. Set to value on motor nameplate.
05.04	Number of Motor Poles	Default is 4. Set to match motor. Eg. 4 pole motor rpm is around 1450rpm.



8.2 Sensorless Vector Setup

Once the above parameters have been changed and checked select parameter 05.00. As default this value is 0. Change to 1 then press ENTER.

Important! Ensure the motor is unloaded - ie that it is decoupled from the load and 'bare shaft' before starting the auto-tune.



8.3 The Auto-tune Process

Press the RUN key to start the auto-tune. The MS300 display will flash 'tUn' and the run lamp will illuminate. Once complete the display will return to the 'F' prefix speed reference.

Note: This test may take a couple of minutes with long pauses. Do not interrupt the auto-tune process to ensure the process completes correctly.

9. How to Connect and Configure a Potentiometer for Remote Speed Control

If speed control via the integrated keypad is unsuitable for the application, a remote potentiometer can be used instead.

This provides the benefit of allowing motor speed to be controlled from a more convenient location such as a cabinet door or on the machine itself.

Any potentiometer from 5kΩ to 10kΩ can be used.

The number of turns required depends on the application. Both single and multiturn potentiometers are available from our website inverterdrive.com.

9.1 Parameters to Check and Values to Set

Parameter	Description	How to Set
03.28	AV1 Range	Default is 0 for 0-10V. Default is required for this example.
03.00	AV1 Selection	Default is 1 for "frequency command". Default is required for this example.
00.20	Master Frequency Command (Auto)	Default is 0 for "keypad control". Set to 2 for "external analogue input".

9.2 Connecting the Potentiometer

A wiring diagram is shown in the illustration opposite. The most important connection is the centre terminal or 'wiper'. The wiper will output a variable voltage between 0 and 10V and should be connected to AV1 on the Inverter; 0V being the slowest and 10V the fastest.

If the rotation of the potentiometer is the opposite to that required (i.e. turn anti-clockwise to increase speed instead of clockwise) reverse connections ACM and 10V.

Use shielded cable between the potentiometer and Inverter and ensure that the cable screen is connected to the Inverter earth terminal only.

The default minimum output frequency is 0Hz (0V input) and is determined by parameter 01.11 (lower limit). If this value is changed, ensure that parameter 01.34 (zero speed mode) is set to 2.

The default maximum output frequency is 50Hz (10V input) and is determined by parameter 01.00 (max frequency).

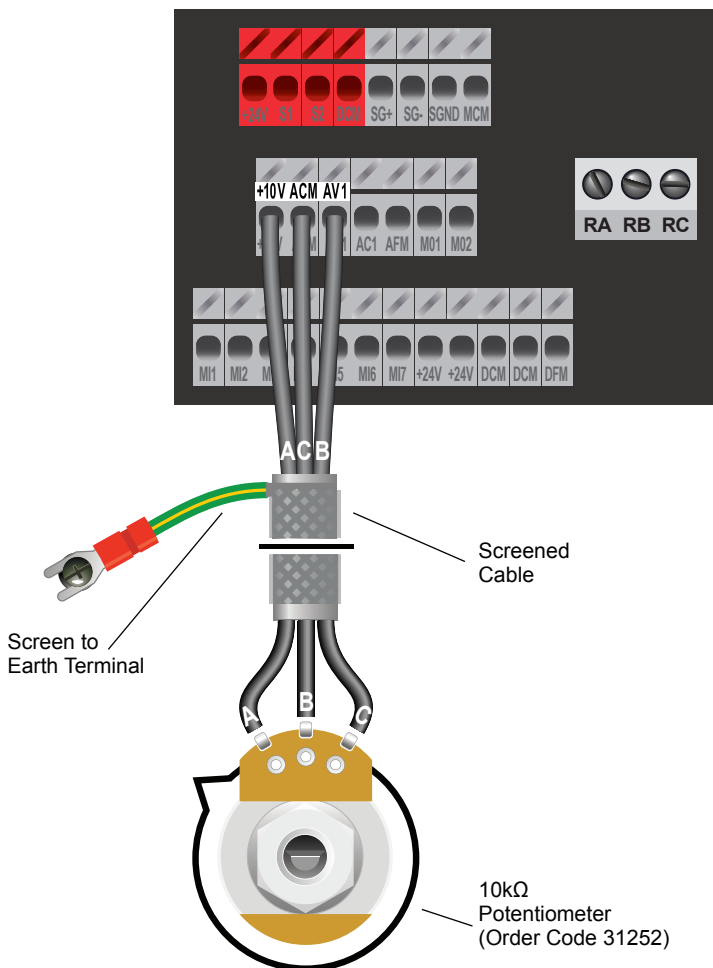

10. How to Connect and Configure a Run Forward or Run Reverse Switch

The procedure described in section 7 enables Run Stop operation via the Inverter keypad.

If this is unsuitable for the application, a remote switch can be used instead.

This section explains how to enable 2-wire control with Run Forward / Stop / Run Reverse commands via a single selector switch.

If reverse control is not required the Run Reverse connection can be omitted.

10.1 Parameters to Check and Values to Set

Parameter	Description	How to Set
00.21	Operation Command Source (Auto)	Default is 0 for "keypad control". Set to 1 for "terminal control".
02.00	Operation Control	Default is 1 for "2-wire control Run FWD". Default is required for this example.

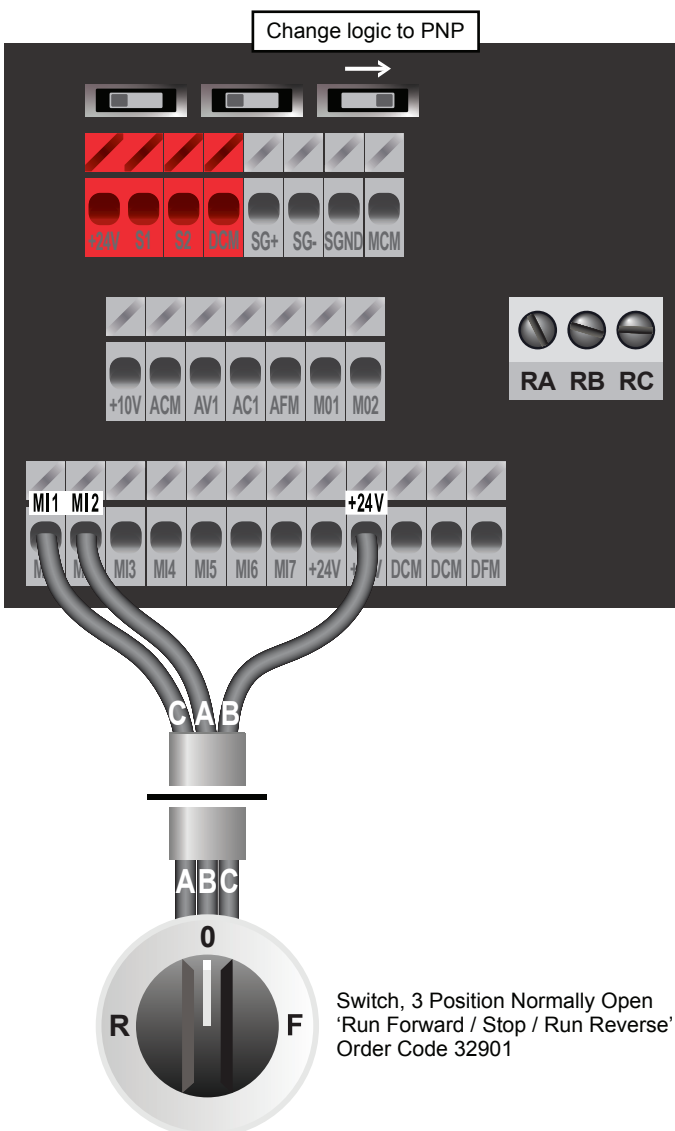

10.2 Connecting the Switch

A wiring diagram is shown in the illustration opposite. 24V is the positive logic (PNP) for terminals MI1 to MI7.

A suitable 3 position 'normally open' switch should be installed between +24V and terminals MI1 and MI2. The centre position should remain open circuit.

When a connection is made between terminals MI1 and +24V, the motor will run forward. When terminals MI2 and +24V are connected the motor will run in reverse.

The motor speed is determined by the local speed ref or analogue input depending on the speed reference selection (see section 9).

NPN / PNP selection is made using the switch as indicated in the diagram. As default the switch position is NPN (left), change to PNP (right) when using 24V as shown.

If NPN is preferred, use DCM instead of 24V.

NPN / PNP selection must match the wiring otherwise the digital inputs will not function.

11. How to Connect and Configure a Run/Stop Switch with Forward/Reverse Selection

The procedure described in section 7 enables Run Stop operation via the Inverter keypad.

If this is unsuitable for the application, a remote switch can be used instead.

This section explains how to enable 2-wire control with Run/Stop and Forward/Reverse commands via separate switches.

If reverse control is not required the direction selector switch can be omitted.

11.1 Parameters to Check and Values to Set

Parameter	Description	How to Set
00.21	Operation Command Source	Default is 0 for "keypad control". Set to 1 for terminal control.
02.00	Operation Control	Default is 1 for "2-wire control Run FWD". Set to 2 for 2-wire control Run/Stop with direction control.

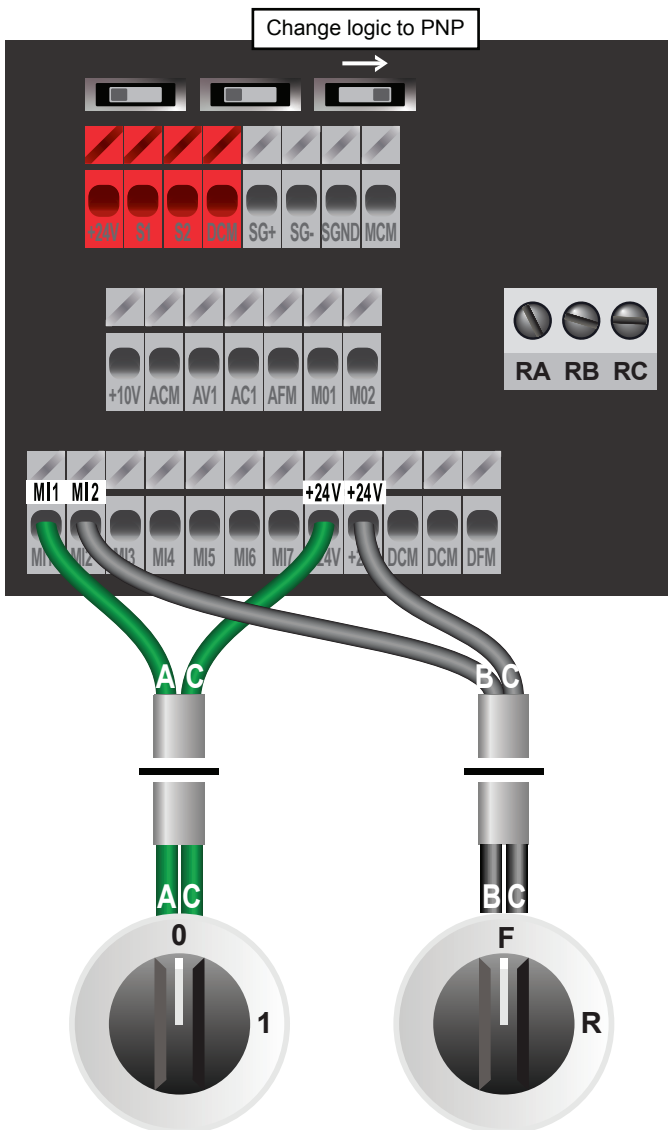

11.2 Connecting the Switch

A wiring diagram is shown in the illustration opposite. 24V is the positive logic (PNP) for terminals MI1 to MI7.

Two suitable 2 position (normally open) switches should be installed between +24V and terminals MI1 and MI2.

When a connection is made between terminals MI1 and +24V the motor will run, when the connection opens the motor will stop. When terminals MI2 and +24V are connected the reverse direction is selected.

The motor speed is determined by the local speed ref or analogue input depending on the speed reference selection (see section 9).

Note that the Forward/Reverse switch only selects the direction of rotation; it will not start or stop the motor. The direction selected is indicated on the keypad. The direction switch can be omitted if only 1 direction is required.

NPN / PNP selection is made using the switch as indicated in the diagram. As default the switch position is NPN (left), change to PNP (right) when using +24V as shown.

If NPN is preferred, use DCM instead of +24V.

NPN / PNP selection must match the wiring otherwise the digital inputs will not function.

Switch, 2 Position Normally Open 'Run/Stop' Order Code 32900
 Switch, 2 Position Normally Open 'Forward/Reverse' Order Code 32900

12. How to Configure 3-wire Control with Run and Stop Pushbuttons and a Forward Reverse Selection Switch

The procedure described in section 7 enables Run Stop operation via the Inverter keypad. If this is unsuitable for the application, remote switches can be used instead.

This section explains how to enable 3-wire control with Run, Stop and Forward/Reverse commands using 2 momentary pushbuttons and a selector switch.

If reverse control is not required the direction selector switch can be omitted.

12.1 Parameters to Check and Values to Set

Parameter	Description	How to Set
00.21	Operation Command Source	Default is 0 for "keypad control". Set to 1 for terminal control.
02.00	Operation Control	Default is 1 for "2-wire control Run FWD". Set to 3 for 3-wire control. Run/Stop with direction control.

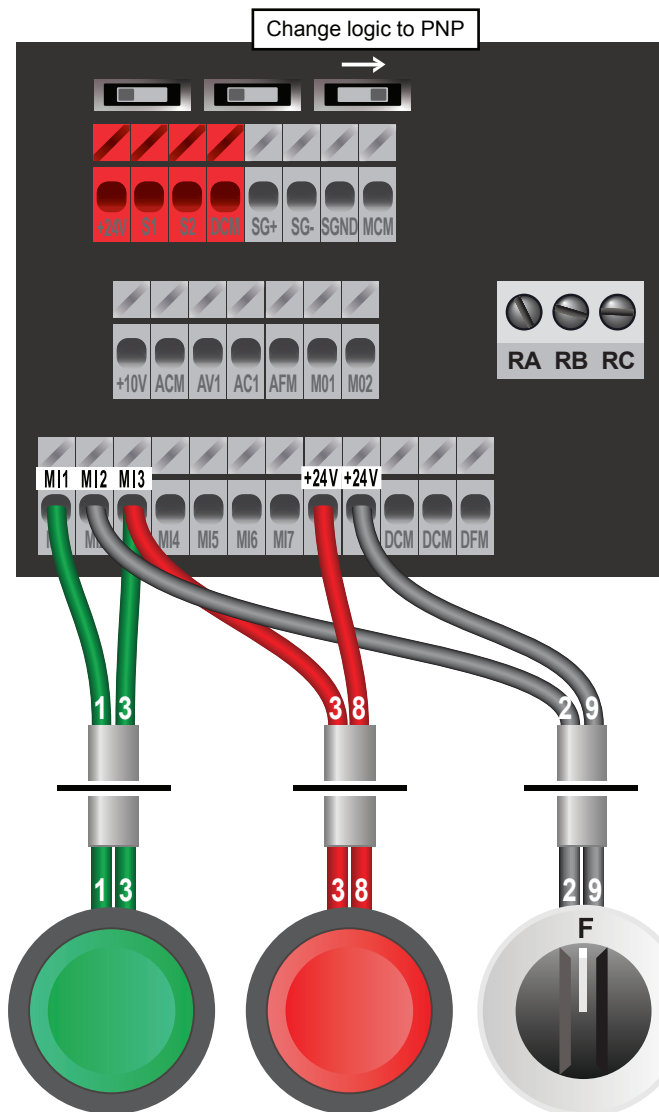

12.2 Connecting the Switches

A wiring diagram is shown in the illustration opposite. 24V is the positive logic (PNP) for terminals MI1 to MI7.

For the 'run' command a pushbutton 'normally open' is required between MI1 and MI3, for the 'stop' command a pushbutton 'normally closed' is required between MI3 and +24V.

A two position 'normally open' switch should be installed between terminals MI2 and +24V for direction selection. This switch will only set the direction and will not stop or start the motor.

The motor speed is determined by the local speed ref or analogue input depending on the speed reference selection (see section 9).

A momentary connection between MI1 and MI3 will start the motor. It will continue to run until the connection between MI3 and +24V is broken. Direction can be reversed by closing the connection between MI2 and +24V.

NPN / PNP selection is made using the switch as indicated in the diagram. As default the switch position is NPN (left), change to PNP (right) when using 24V as shown.

If NPN is preferred, use DCM instead of 24V.

NPN / PNP selection must match the wiring otherwise the digital inputs will not function.

Pushbutton Normally Open "Run" Order Code 32896
 Pushbutton Normally Closed "Stop" Order Code 32895
 Switch, 2 Position Normally Open "Forward/Reverse" Order Code 32902

13. Brake Resistor Connection



Before you begin, confirm that the inverter and all cables are completely isolated from the power supply, have been isolated for at least 5 minutes and that the motor is not turning.

High inertia loads can cause overvoltage trips during deceleration and lead to 'ovS' error messages. In many cases, the solution is to increase the deceleration time to compensate.

However, if the application requires it, dynamic braking can be enabled to maintain or reduce deceleration times by absorbing the energy generated by such loads.

A brake resistor is first installed to absorb braking energy and dissipate it as heat. The resistor must be correctly sized for both the Inverter and the application.

The brake chopper within the MS300 must be enabled to ensure that when excessive braking energy is detected it redirects the energy into the braking resistor.

13.1 Parameters to Check and Values to Set

Parameter	Description	How to Set
01.49	Regen Energy Restriction	Default is 0 for "no restriction". Set to 1 to enable voltage monitoring parameters.
06.01	Stall Prevention	Default is enabled (380V or 760V). Set to 0 to disable this function and ensure deceleration time is not extended.
06.02	Over Voltage Prevention	Default is 0 for "traditional over-voltage stall prevention". Default is required.

13.2 Connecting the Resistor

A wiring diagram is shown in the illustration opposite. Connect the brake resistor to the +2/B1 and BR terminals on the Inverter - the order is unimportant.

The brake resistor may get hot in operation. Ensure that it is mounted in a suitable position at least 10cm away from other items.

It is important that a resistor of the correct rating is used. Consult the manufacturer's manual or product listing at inverterdrive.com for further information.

There is a link between DC+ / +1 and +2 / B1; DO NOT remove this link as the Inverter will not operate.

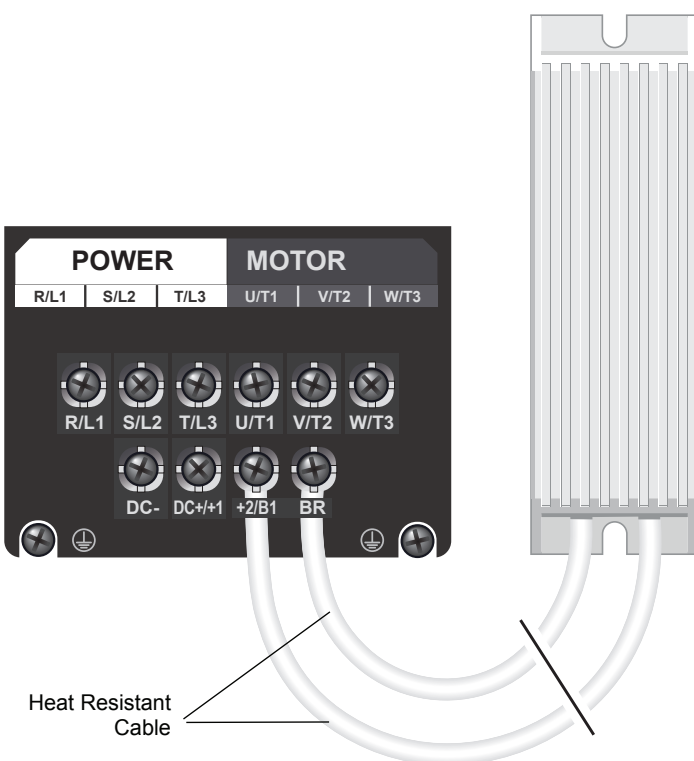

14. STO (Safe Torque Off) Connections



This section is an overview only. You must also refer to the manual provided by the manufacturer for full details of STO functionality.

Safe Torque Off (STO) is a feature that is included on all MS300 products.

STO provides a facility to disable the output of the Inverter so that the motor it is controlling cannot be operated ie. that no torque can be applied. However, it does not provide any form of braking so will not prevent the load from rotating the motor.

The STO function is only effective when wired to suitable safety devices that detect an 'unsafe' situation. A safety assessment of the machinery is required by suitably qualified personnel to identify what should be considered unsafe and what safety devices are appropriate for the application.

It is not recommended to stop a motor using the Inverter STO function. The motor should be stopped before the STO feature is activated.

STO does not isolate the electrical supply. Therefore the Inverter must be isolated from the supply before any maintenance is carried out.

14.1 STO Links

The MS300 is supplied with links configured so that the Inverter can be used with the STO

disabled. If the STO is required remove both links and replace with a suitable safety device.

STO Disabled

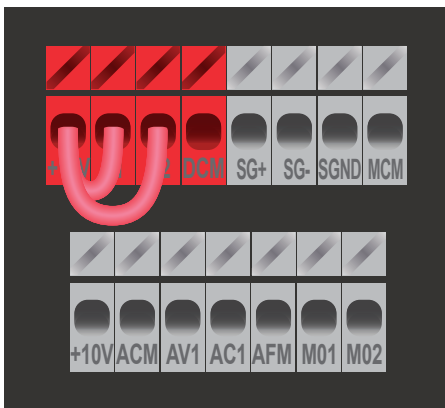

Internal 24V is used to disable the safety function. External 24V supply is recommended for safety function operation.

STO Enabled

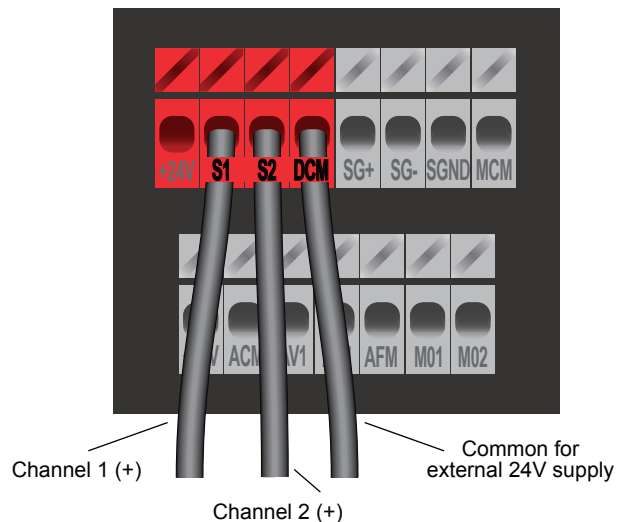

14.2 Keypad

When a dual channel safety device is wired to the Inverter and both channels are closed (safe) the Inverter can be operated as normal.

If one or both of the channels open, the Inverter will indicate an STO fault and cannot be operated.



15. How to Reset the Inverter to Factory Defaults



15.1 Access the Parameter List

With the motor stopped and any fault or alarm messages cleared press the MODE key three times, then the ENTER key once to access the parameter list.

The display will show parameter group 00 or the last parameter group changed.



15.2 Select Parameter 00.02

Use the ▲ and ▼ keys to locate parameter group 00 then press ENTER.

The parameter number will now show next to the parameter group.

Use ▲ and ▼ keys to select parameter number 00.02 then press ENTER.



15.3 Set the Value to 9

The default is 0. Use the ▲ and ▼ keys to change the value from 0 to 9 to load the 50Hz default values. Press ENTER to reset the parameter values.



15.4 The Inverter Resets

Once complete the keypad will display *End* briefly before reverting to the speed reference of F50.00.

Note: The value of 00.02 returns to 0 once reset is complete.