

## Universal Motors UMB1 Frequency Inverter (to 2.2kW)

# Easy Start Guide



The Universal Motors UMB1 Frequency Inverter range is available to order from [inverterdrive.com](http://inverterdrive.com)

This guide provides step-by-step instructions for wiring, configuring, and commissioning the Universal Motors UMB1 inverter. It includes parameter explanations, wiring diagrams, and essential setup guidance. The document is intended to complement the official manufacturer's manual and must not be used as a replacement for it.



**This product is not a safety device. All safety considerations including but not limited to Emergency Stop provision should be assessed separately and are outside the scope of this guide.**

## Contents

Page 1	Contents
Page 2	Power and Motor Connections (Single Phase)
Page 3	Power and Motor Connections (Three Phase)
Page 4	Motor Connections - Star and Delta
Page 5	Parameters - Overview Parameters to Set Before Use
Page 6	How to Set a Parameter Value
Page 7	How to Operate the Inverter from the Keypad
Page 8	How to Enable Sensorless Vector Mode
Page 9	How to Connect and Configure a Potentiometer for Remote Speed Control
Page 10	How to Connect and Configure a Run Forward or Run Reverse Switch
Page 11	How to Connect and Configure a Run/Stop Switch with Forward/Reverse Selection
Page 12	How to Configure 3-Wire Control with Run and Stop Pushbuttons and a Forward Reverse Selection Switch
Page 13	Brake Resistor Connection
Page 14	EMC Filter Connection (Optional)
Page 15	STO (Safe Torque Off) Connections
Page 16	How to Reset the Inverter to Factory Defaults

# Easy Start Guide

Universal Motors UMB1 Frequency Inverter (to 2.2kW)

## 1. Power and Motor Connections (Single Phase)



**Before you begin, confirm that the inverter and all cables are completely isolated from the power supply, have been isolated for at least 5 minutes and that the motor is not turning.**

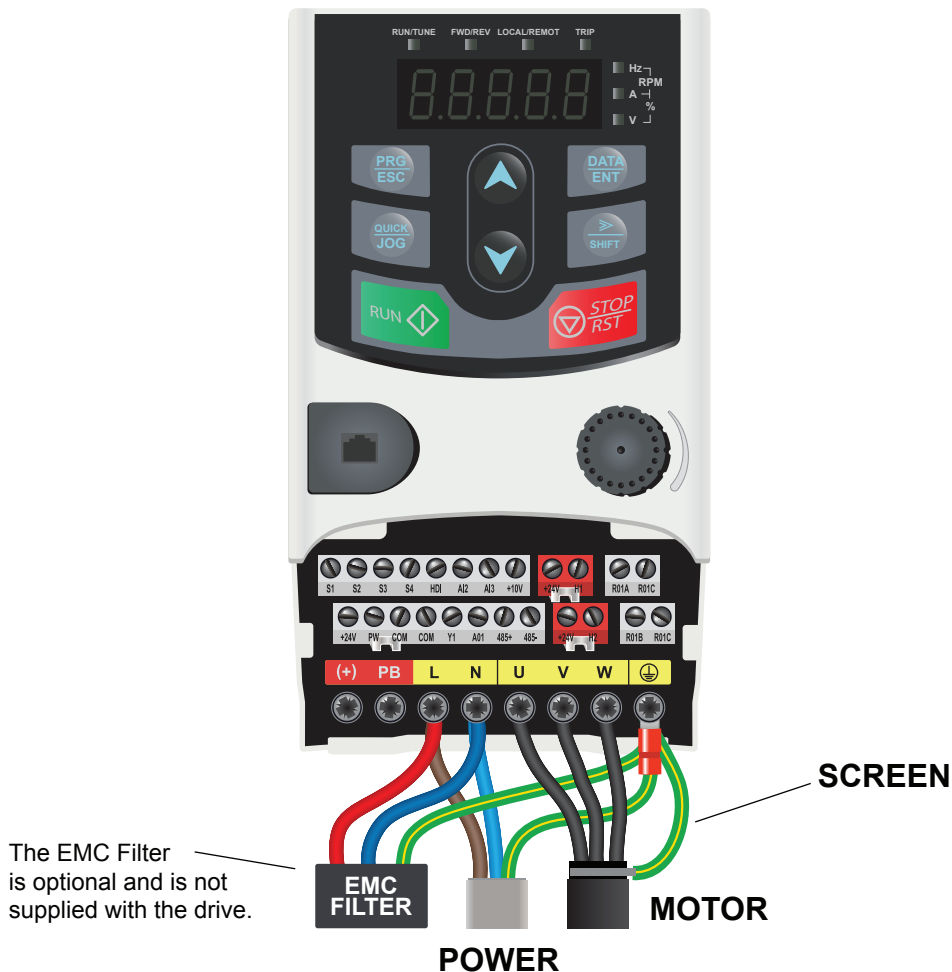

### Notes:

The illustration above is based on the 0.75kW rating (size 1). The terminals for other ratings are similarly labelled.

The supply must match the Inverter specification.

Applying 400V to a 230V unit will cause damage to the Inverter.

### Important:

The order of the three motor phases determines the initial direction the motor turns.

This can be reversed by swapping any two phases or changing the Inverter parameters.

Use screened or armoured cable between the Inverter and motor and ensure it is grounded as shown.

## 2. Power and Motor Connections (Three Phase)



Before you begin, confirm that the inverter and all cables are completely isolated from the power supply, have been isolated for at least 5 minutes and that the motor is not turning.

Size 2

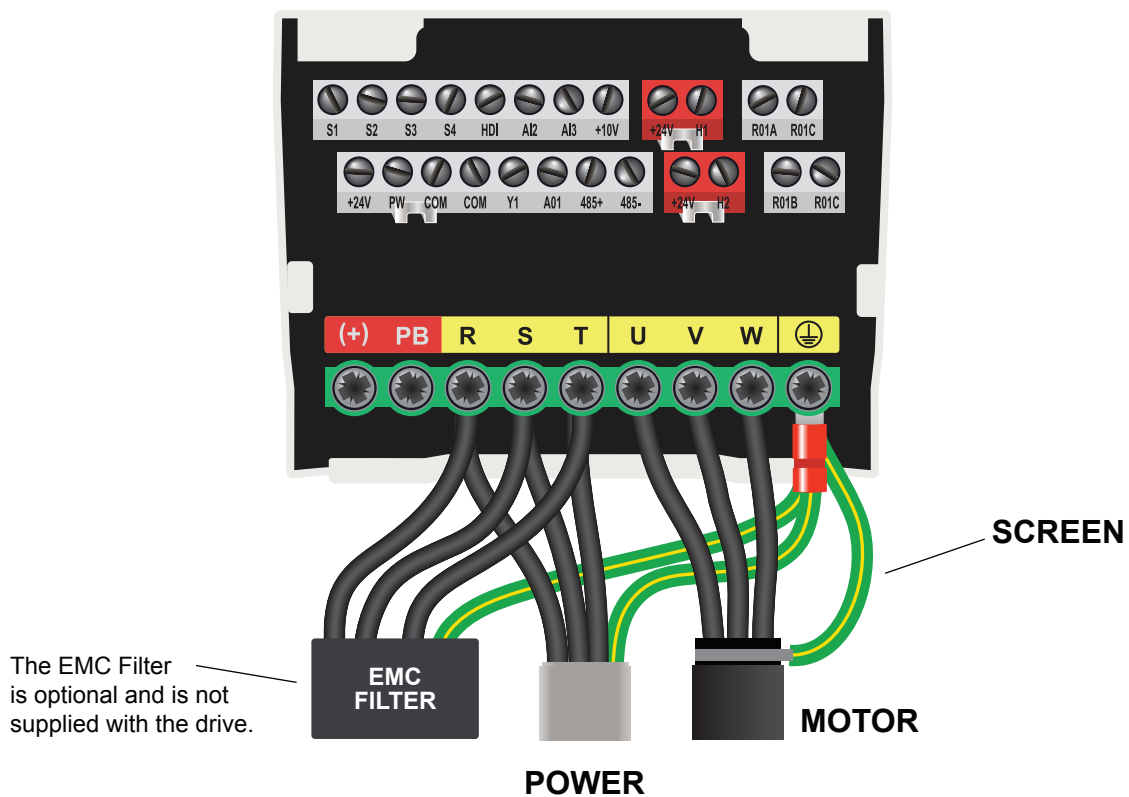

### Notes:

The illustration above is based on the 1.5kW (size 2) rating. The terminals for other ratings are similarly labelled.

The supply voltage must match the Inverter specification.

Applying 400V to a 230V unit will cause damage to the Inverter.

### Important:

The order of the three motor phases determines the initial direction the motor turns.

This can be reversed by swapping any two phases.

Use screened or armoured cable between the Inverter and motor and ensure it is grounded as shown.

## 3. Motor Connections - Star and Delta

Dual voltage induction motors typically include terminal boxes with six points. The points can be connected together with links in one of two ways to suit one of the two rated voltages.

The two ways of connecting the links are shown below. These are known as 'Star' (the higher voltage) or 'Delta' (the lower voltage).

**The selection of Star or Delta is not optional and must match the supply voltage.**

Dual voltage motor name plates include symbols to represent voltage and full load current in each configuration.

Delta is represented by a triangle and Star by a Y (Wye).

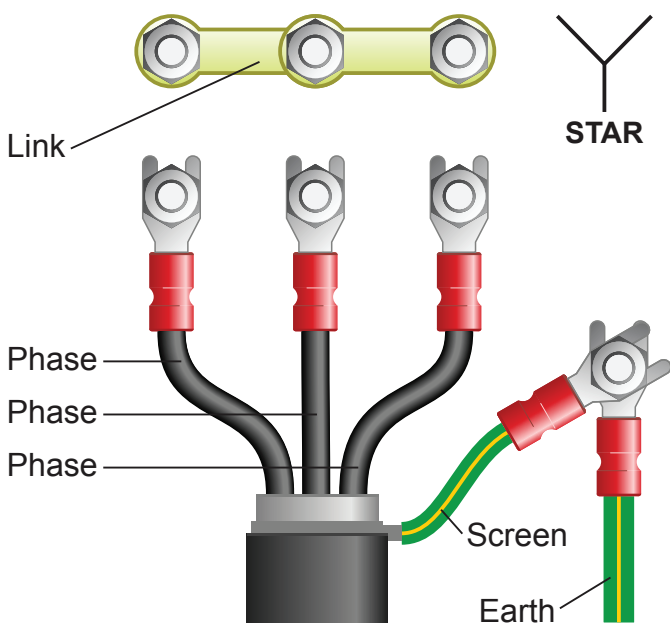

### 3.1 Motor Connected in STAR (or Wye):

For safety purposes, Star (shown opposite is the default configuration for small motors (usually to 3kW) and is sometimes known as 'two at one side'.

Only two links are required for Star. Double-up the links if changing from Delta to allow the motor to be changed back in future.

The order of the three phases determines the direction the motor turns.

*Note that the manufacturer recommends that the cable screen is earthed at both ends and the motor and inverter are permanently and separately earthed.*

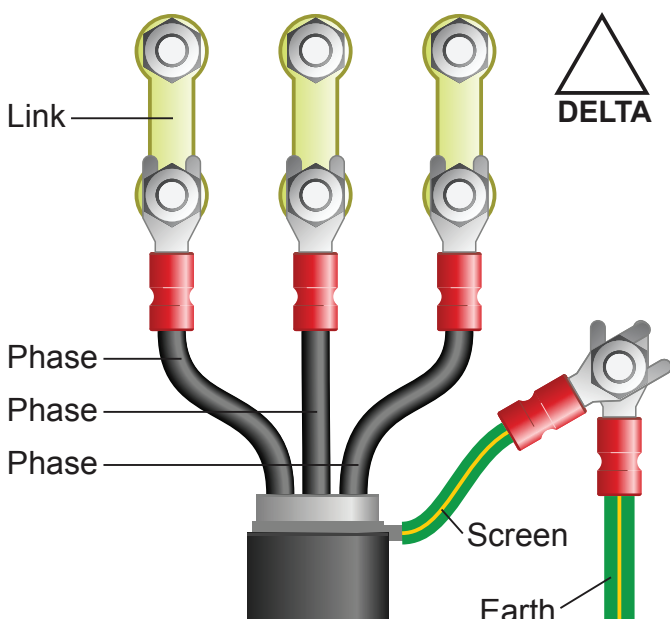

### 3.2 Motor Connected in DELTA:

The link configuration is shown in the illustration opposite and is sometimes referred to as 'three-a-breast'.

The order of the three phases determines the direction the motor turns.

*Note that the manufacturer recommends that the cable screen is earthed at both ends and the motor and inverter are permanently and separately earthed.*

### 4. Parameters - Overview

The Inverter contains a number of settings which can be changed to tailor it for use in a wide range of applications. These settings are known as parameters.

Parameters are typically referred to by code or number (e.g. P02.05 = rated current) with a description available in the manual.

The parameters contain critical information essential for correct operation of the Inverter. Please see the recommendations below; Inverters that are not commissioned correctly may underperform or trip unexpectedly.

The parameters listed in section 5 are intended to provide a starting point for basic operation of the UMB1 Inverter. The UMB1 product manual should be used for all other parameters.

### 5. Parameters to Set Before Use

Set the following parameters to allow the UMB1 to control a 50Hz induction motor in V/F control.

Further parameters are required to determine the speed and command reference, see sections 9, 10, 11 and 12.

**See section 6 to learn how to set a parameter value**

#### 5.1 Parameters to Check and Values to Set

Parameter	Description	How to Set
P00.00	Speed Control Mode	Default is <b>2</b> , V/F control. Default will suit most applications. See page 8 for sensorless vector control for high torque applications.
P00.04	Upper Limit of Running Freq (Hz)	Default is <b>50Hz</b> . Default is suitable for many applications.
P00.05	Lower Limit of Running Freq (Hz)	Default is <b>0Hz</b> . Default is suitable for many applications.
P00.11	Acceleration Time (s)	Default is <b>10s</b> . Default is suitable for many applications.
P00.12	Deceleration Time (s)	Default is <b>10s</b> . Default is suitable for many applications.
P00.14	Carrier Frequency	Default is rating dependant. Default is suitable for most applications. Increase to reduce motor noise but with caution as this will de-rate the unit.
P01.08	Stop Selection	Default is <b>0</b> , ramp to stop. Default is suitable for many applications. Set to 1 for coast to stop.
P02.01	Rated Power (of motor) (kW)	Default is product dependant. <b>Set to value on motor nameplate.</b>
P02.02	Rated Frequency (of motor) (Hz)	Default is 50Hz, motor frequency. <b>Set to value on motor nameplate.</b>
P02.03	Rated Speed (of motor) (rpm)	Default is 1400rpm (50Hz). <b>Set to value on motor nameplate.</b>
P02.04	Rated Voltage (of motor) (V)	Default is product dependant. <b>Set to value on motor nameplate</b> , normally 230V or 400V and will match the supply voltage.
P02.05	Rated Current (of motor) (A)	Default is product dependant. <b>Set to value on motor nameplate.</b>
P04.00	V/F Curve Setting	Default is <b>0</b> , linear. Default will suit constant torque (heavy duty) applications. For variable torque (fan and centrifugal pump) applications, set to 4.

## 6. How to Set a Parameter Value



### 6.1 Select the Parameter Group

In this example, we will set the value of parameter **P02.05 (motor rated current)**.

With the motor stopped and any fault or alarm messages cleared press the  $\frac{\text{PRG}}{\text{ESC}}$  key repeatedly until the parameter group menu (prefixed with P) is displayed.

Use the  $\blacktriangle$  and  $\blacktriangledown$  keys to select parameter group P02.

Press  $\frac{\text{DATA}}{\text{ENT}}$  to select parameters within this group.



### 6.2 Select the Parameter

Use the  $\blacktriangle$  and  $\blacktriangledown$  keys to select parameter P02.05.

Press  $\frac{\text{DATA}}{\text{ENT}}$  to edit the value.



### 6.3 Set the Parameter Value

Use the  $\blacktriangle$  and  $\blacktriangledown$  keys to set the required value. In this example 1.4A.

Use the shift key to move between digits if required.

To save the changes press  $\frac{\text{DATA}}{\text{ENT}}$ .

Once the changes are saved, the display will show the next parameter in the group.

Press  $\frac{\text{PRG}}{\text{ESC}}$  to return to the parameter group and  $\frac{\text{PRG}}{\text{ESC}}$  again to return to the main display.

## 7. How to Operate the Inverter from the Keypad



### 7.1 Select Local Control

As default the UMB1 is set for keypad control.

If this may have changed, ensure the value of parameter P00.01 (start/stop command) is set to 0 for local control.

To learn how to set a parameter value refer to section 6.



### 7.2 Set the Speed Reference with the ▲ and ▼ Keys

Set the value of P00.06 to 0 using the ▲ and ▼ keys and P00.09 to 0 (keypad frequency command).

Press the  $\frac{\text{PRG}}{\text{ESC}}$  button repeatedly until the speed reference is displayed (the Hz indicator will illuminate).

Use the ▲ and ▼ keys to set the desired speed. **Use the shift key to move between digits.**

Note: The keypad speed reference is stored, so it will be remembered after the Inverter is powered off.



### 7.3 Or, select the Speed Reference with the Dial

Set the value of P00.06 to 1 (dial) and P00.09 to 0 (keypad frequency command).

Press the  $\frac{\text{PRG}}{\text{ESC}}$  button repeatedly until the speed reference is displayed (the Hz indicator will illuminate).

Turn the dial to set the desired speed.



### 7.4 Start and Stop the Motor

Press the green RUN key to start the motor.  
Press the red STOP key to stop the motor.

When running the 'run' indicator will illuminate.

During deceleration the 'run' indicator will remain on until the motor is stopped.

## 8. How to Enable Sensorless Vector Mode

The standard operating mode for the UMB1 is V/F. This is the simplest form of operation and controls volts and frequency to vary the speed of a standard induction motor. The manufacturer refers to this as SVPWM.

The UMB1 can also be operated in sensorless vector mode. This can improve the motor performance without requiring a separate feedback device.

In order to improve performance, sensorless vector requires a number of values to build a 'model' of the motor it is controlling. These are described below.

**Note: Sensorless vector control is not suitable where the motor rating is significantly less than the Inverter rating or where more than one motor is being controlled from a single Inverter.**

### 8.1 Parameters to Check and Values to Set for a Constant Torque (heavy duty) Load

Parameter	Description	How to Set
P00.00	Speed Control Mode	Default is 2, V/F control. Set to <b>0</b> for sensorless vector control (SVC).
P02.01	Rated Power (of motor) (kW)	Default is product dependant. <b>Set to value on motor nameplate.</b>
P02.02	Rated Freq (of motor) (Hz)	Default is 50Hz. Motor frequency. <b>Set to value on motor nameplate.</b>
P02.03	Rated Speed (of motor) (rpm)	Default is 1400rpm. <b>Set to value on motor nameplate.</b>
P02.04	Rated Voltage (of motor) (V)	Default is product dependant. <b>Set to value on motor nameplate.</b> Will normally be 230V or 400V and will match the supply voltage.
P02.05	Rated Current (of motor) (A)	Default is product dependant. <b>Set to value on motor nameplate.</b>



### 8.2 Sensorless Vector Setup

Once the above parameters have been changed, an auto-tune can be run.

Set the value of parameter P00.15 to 2 to perform a static auto-tune.

As soon as this value is set, RUN appears on the display.



### 8.3 The Auto-tune Process

Press RUN to start the auto-tune. The display will initially show run-1 with the tune and remote indicators flashing.

The process takes a few minutes and changes from Tune-1 to Tune-2 to Tune-3 as it progresses.

Once complete, - END - will briefly appear on the display.

**Note: The keypad RUN key will only start the auto-tune if P00.01 is set to 0.**

## 9. How to Connect and Configure a Potentiometer for Remote Speed Control

If speed control via the integrated keypad is unsuitable for the application, a remote potentiometer can be used instead.

This provides the benefit of allowing motor speed to be controlled from a more convenient location such as a cabinet door or on the machine itself.

Any potentiometer from 5kΩ to 10kΩ can be used.

The number of turns required depends on the application. Both single and multiturn potentiometers are available from our website [inverterdrive.com](http://inverterdrive.com).

### 9.1 Parameters to Check and Values to Set

Parameter	Description	How to Set
P00.03	Max Output Frequency (Hz)	Default is <b>50Hz</b> . Default will suit many applications.
P00.07	Frequency Command B	Default is <b>2</b> , analogue input 2 (AI2). Default is required in this example.
P00.09	Frequency Source Combination	Default is 0, frequency command A. Set to <b>1</b> , frequency command B.
P05.38	Low Limit of AI2 (%)	Default is <b>0%</b> . Default will suit many applications.
P05.40	Upper Limit of AI2 (%)	Default is <b>100%</b> . Default will suit many applications.

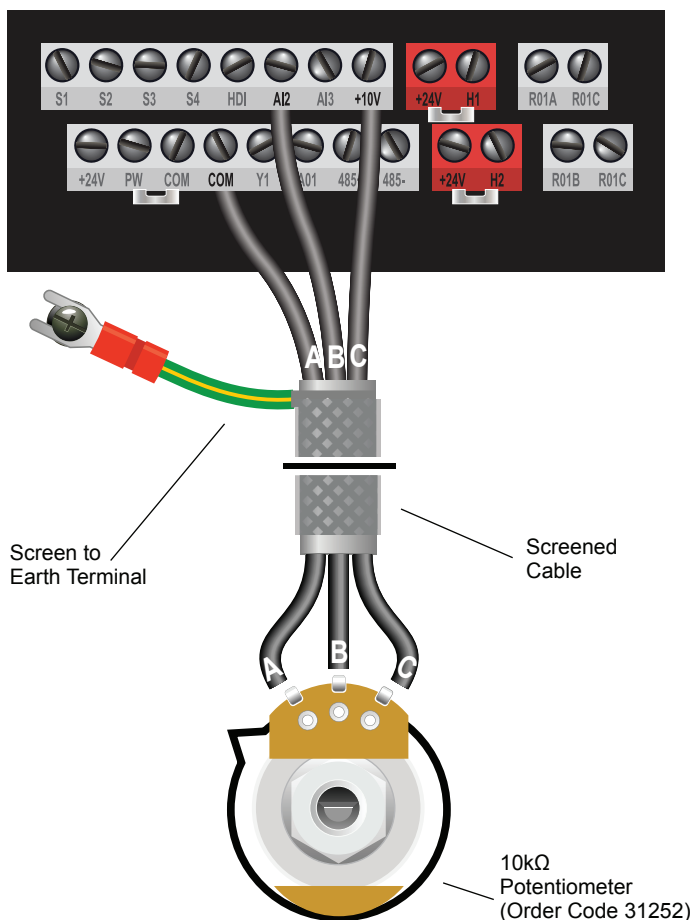

### 9.2 Connecting the Potentiometer

In the wiring diagram opposite, the most important connection is the centre terminal or 'wiper'. The wiper will output a variable voltage between 0 and 10V and should be connected to AI2 on the Inverter. It is this voltage which provides the speed signal with 0V being the slowest and 10V the fastest.

If the rotation of the potentiometer is the opposite to that required reverse connections COM and +10V.

Use shielded cable between the potentiometer and inverter and ensure that the cable screen is connected to the inverter earth terminal only.

The default minimum output frequency is 0Hz and is determined by parameter P05.38. Setting P05.38 to 60% ensures that the motor will not run at a speed below 30Hz.

The default maximum output frequency is 50Hz and is determined by parameter P05.40. Setting P05.40 to 90% will limit the maximum speed to 45Hz when speed reference is 10V.

## 10. How to Connect and Configure a Run Forward or Run Reverse Switch

The procedure described in section 7 enables Run / Stop operation via the Inverter keypad.

If this is unsuitable for the application, a remote switch can be used instead.

This section explains how to enable 2-wire control with Run Forward / Stop / Run Reverse commands via a single selector switch.

If reverse control is not required the Run / Reverse connection can be omitted.

### 10.1 Parameters to Check and Values to Set

Parameter	Description	How to Set
P00.01	Run Command	Default is 0, keypad control. Set to <b>1</b> for terminal control.
P05.01	S1 Terminal Function	Default is <b>1</b> , run forward. Default is required in this example.
P05.02	S2 Terminal Function	Default is 4, forward jog. Set to <b>2</b> for run reverse operation.
P05.13	Terminal Control Mode	Default is <b>0</b> , run forward / run reverse. Default is required in this example.

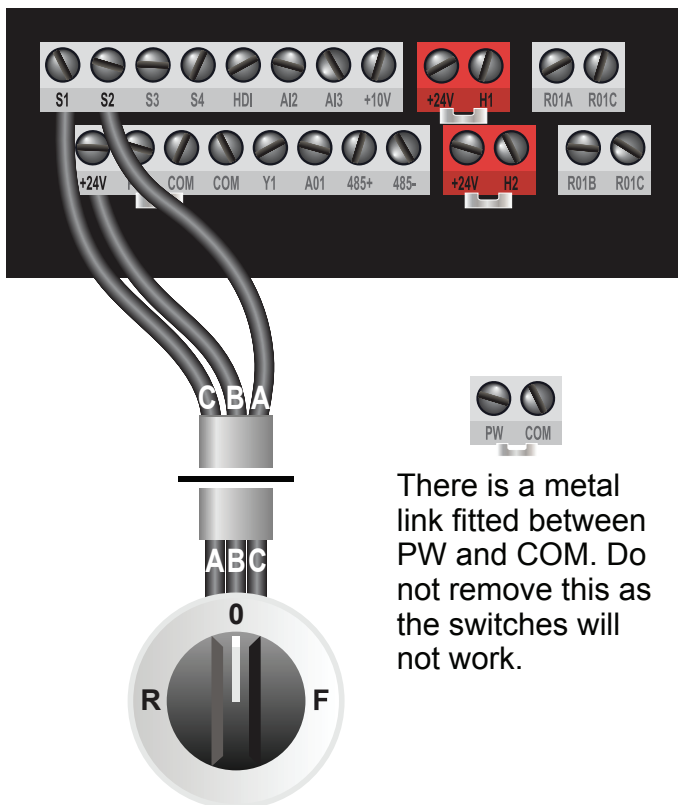

There is a metal link fitted between PW and COM. Do not remove this as the switches will not work.

Switch, 3 Position  
Normally Open  
'Run Forward / Stop / Run Reverse'  
Order Code 32901

### 10.2 Connecting the Switch

A wiring diagram is shown in the illustration opposite. +24V is the positive logic (PNP) for terminals S1 and S2.

A suitable 3 position 'normally open' switch should be installed between +24V and terminals S1 and S2. The centre position should remain open circuit.

When a connection is made between terminals S1 and +24V, the motor will run forward. When terminals S2 and +24V are connected the motor will run in reverse.

**The motor speed is determined by the local speed ref or analogue input depending on the speed reference selection.**

## 11. How to Connect and Configure a Run/Stop Switch with Forward/Reverse Selection

The procedure described in section 7 enables Run / Stop operation via the Inverter keypad.

If this is unsuitable for the application, a remote switch can be used instead.

This section explains how to enable 2-wire control with Run / Stop and Forward / Reverse commands via a single selector switch.

If reverse control is not required the direction selector switch can be omitted.

### 11.1 Parameters to Check and Values to Set

Parameter	Description	How to Set
<i>P00.01</i>	Run Command	Default is 0, keypad control. Set to <b>1</b> for terminal control.
<i>P05.01</i>	S1 Terminal Function	Default is <b>1</b> , run forward. Default is required in this example.
<i>P05.02</i>	S2 Terminal Function	Default is 4, forward jog. Set to <b>2</b> for reverse operation.
<i>P05.13</i>	Terminal Control Mode	Default is 0, run forward / run reverse. Set to <b>1</b> for run with reverse select.

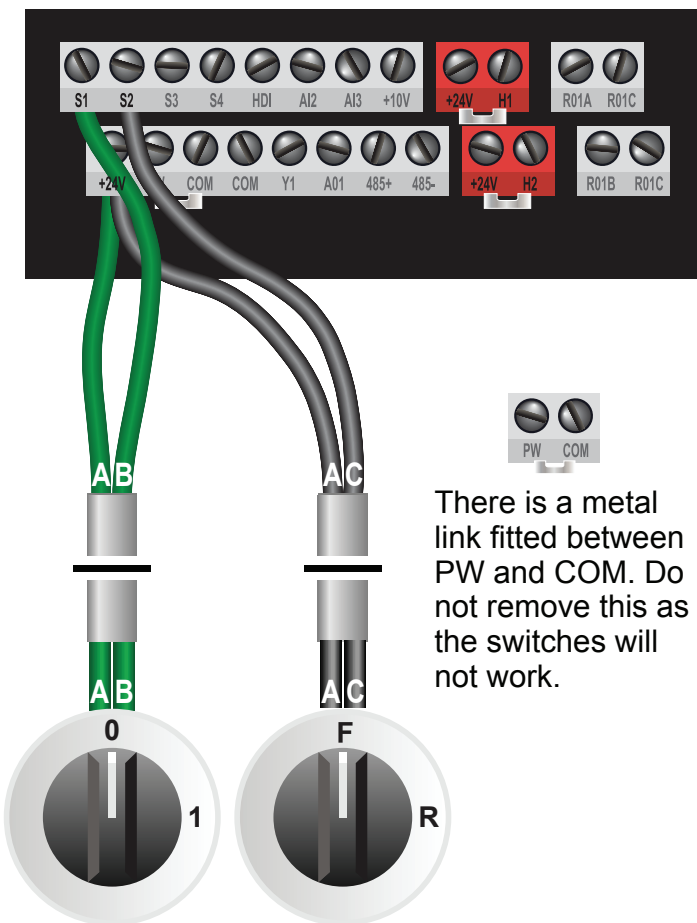

### 11.2 Connecting the Switch

A wiring diagram is shown in the illustration opposite. +24V is the positive logic (PNP) for terminals S1 and S2.

Two suitable 2 position 'normally open' switches should be installed between +24V and terminals S1 and S2.

When a connection is made between terminals S1 and +24V the motor will run, when the connection opens the motor will stop. When terminals S2 and +24V are connected the reverse direction is selected.

**The motor speed is determined by the local speed ref or analogue input depending on the speed reference selection.**

Note that the forward / reverse switch only selects the direction of rotation; it will not start or stop the motor. The direction selected is indicated on the keypad. The direction switch can be omitted if only 1 direction is required.

Switch, 2 Position Normally Open 'Run/Stop' Order Code 32902  
 Switch, 2 Position Normally Open 'Forward/Reverse' Order Code 32902

## 12. How to Configure 3-wire Control with Run and Stop Pushbuttons and a Forward Reverse Selection Switch

The procedure described in section 7 enables Run / Stop operation via the Inverter keypad. If this is unsuitable for the application, remote switches can be used instead.

This section explains how to enable 3-wire control with Run / Stop and Forward / Reverse commands using 2 momentary pushbuttons and a selector switch.

If reverse control is not required the direction selector switch can be omitted.

### 12.1 Parameters to Check and Values to Set

Parameter	Description	How to Set
P00.01	Run Command	Default is 0, keypad control. Set to 1 for terminal control.
P05.01	S1 Terminal Function	Default is 1, run forward. Default is required in this example.
P05.02	S2 Terminal Function	Default is 4, forward jog. Set to 2 for reverse operation.
P05.03	S3 Terminal Function	Default is 7, fault reset. Set to 3 for normally closed operation.
P05.13	Terminal Control Mode	Default is 0, run forward / run reverse. Set to 2 for 3-wire control.

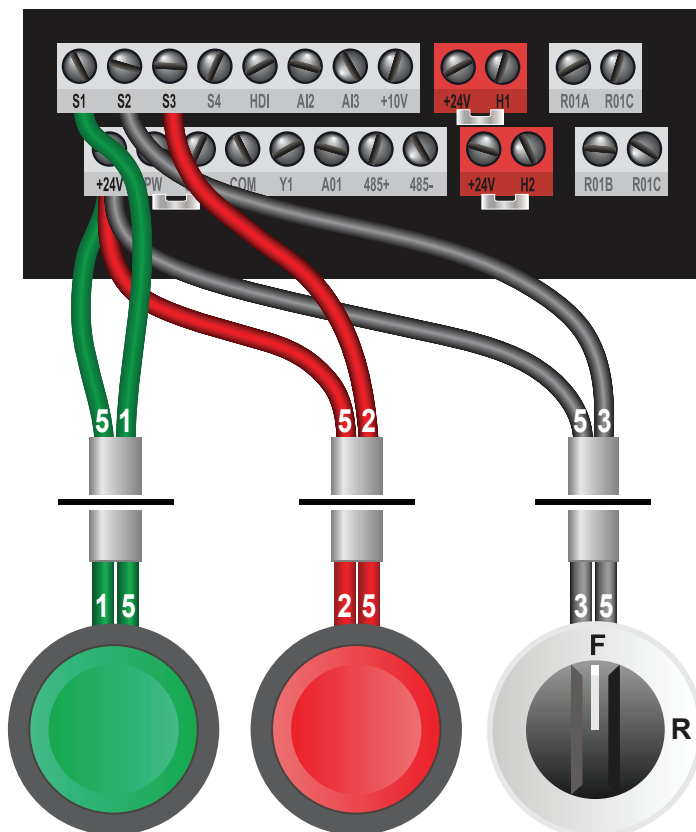

### 12.2 Connecting the Switches

A wiring diagram is shown in the illustration opposite. +24V is the positive logic (PNP) for terminals S1, S2 and S3.

Two suitable pushbuttons should be installed between terminals +24V and S1 for the 'run' command and between terminals +24V and S3 for the 'stop' command.

The 'run' contact should be 'normally open' and the 'stop' contact should be 'normally closed'.

One suitable 2 position 'normally open' switch should be installed between terminals 24V and S2 for direction selection.

**The motor speed is determined by the local speed ref or analogue input depending on the speed reference selection.**

A momentary connection between +24V and S1 will start the motor. It will continue to run until the connection between 24V and S3 is broken. Direction can be reversed by closing the connection between 24V and S2.

**Note: There is a metal link fitted between PW and COM. Do not remove this as the switches will not work.**

Pushbutton Normally Open "Run" Order Code 32896  
 Pushbutton Normally Closed "Stop" Order Code 32895  
 Switch, 2 Position Normally Open "Forward/Reverse" Order Code 32902

## 13. Brake Resistor Connection



**Before you begin, confirm that the inverter and all cables are completely isolated from the power supply, have been isolated for at least 5 minutes and that the motor is not turning.**

High inertia loads can cause overvoltage trips during deceleration and lead to 'OV2' error messages. In many cases, the solution is to increase the deceleration time to compensate.

However, if the application requires it, dynamic braking can be enabled to maintain or reduce

deceleration times by absorbing the energy generated by such loads.

A brake resistor is first installed to absorb braking energy and dissipate it as heat. The resistor must be correctly sized for both the Inverter and the application.

### 13.1 Parameters to Check and Values to Set

Parameter	Description	How to Set
P08.37	Energy Brake Enable	Default is 0, disabled. Set to 1, enabled.
P08.38	Brake and Threshold Voltage	Default is 380V for 230V supply and 700V for 400V supply. Set to min value of <b>375V</b> for 230V supply or <b>685V</b> for 400V supply.
P11.03	Overvoltage Stall Protection	Default is 1, enabled. Set to <b>0</b> , disabled only when a suitable brake resistor is fitted.

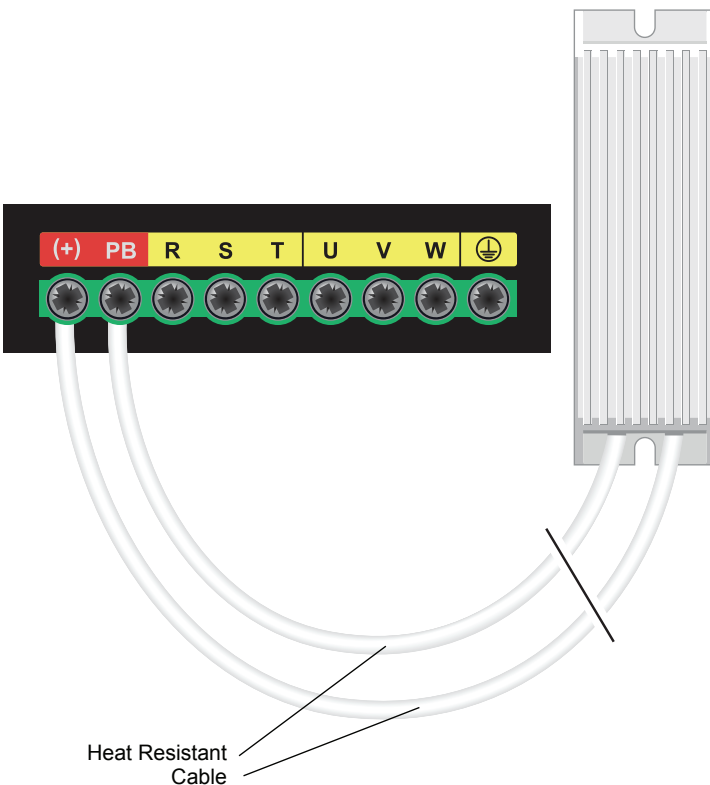

### 13.2 Connecting the Resistor

A wiring diagram is shown in the illustration opposite. Connect the brake resistor to the (+) and PB terminals on the Inverter - the order is unimportant.

The brake resistor may get hot in operation. Ensure that it is mounted in a suitable position at least 10cm away from other items.

It is important that a resistor of the correct rating is used. Consult the manufacturer's manual or product listing at [inverterdrive.com](http://inverterdrive.com) for further information.

## 14. EMC Filter Connection (Optional)

UMB1 AC Inverters are not supplied with an EMC filter. However, an external EMC filter is available to order if required.

These filters are fitted at the base of the UMB1 in parallel with the AC input terminals.

Connection details are shown below for a 0.75kW frame size 1 230V unit, and 1.5kW frame size 2 400V unit, but other frame sizes are similar.

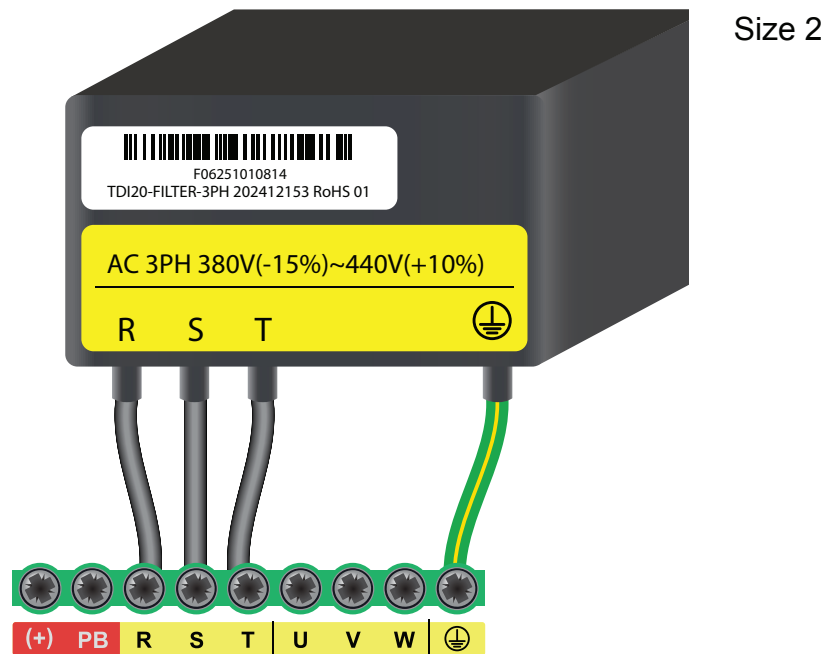
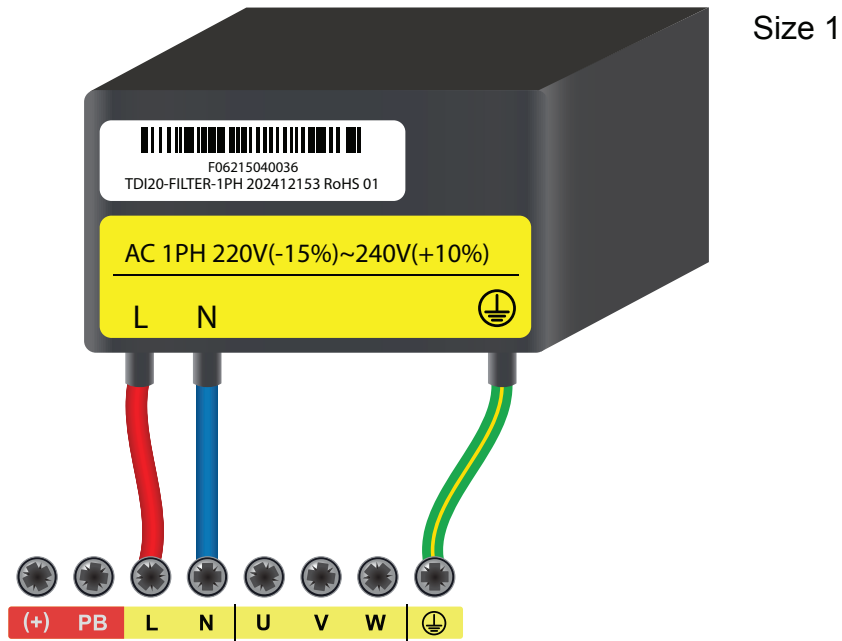

## 15. STO (Safe Torque Off) Connections



**This section is an overview only. You must also refer to the manual provided by the manufacturer for full details of STO functionality.**

Safe Torque Off (STO) is a feature that is included on all UMB1 products.

STO provides a facility to disable the output of the Inverter so that the motor is it controlling cannot be operated ie. that no torque can be applied. However, it does not provide any form of braking so will not prevent the load from rotating the motor.

The STO function is only effective when wired to suitable safety devices that detect an 'unsafe' situation. A safety assessment of the machinery is required by suitably qualified personnel to identify what should be considered unsafe and what safety devices are appropriate for the application.

It is not recommended to stop a motor using the Inverter STO function. The motor should be stopped before the STO feature is activated.

STO does not isolate the electrical supply. Therefore the Inverter must be isolated from the supply before any maintenance is carried out.

### 15.1 STO Links

The UMB1 is supplied with links configured so that the Inverter can be used with the

STO disabled. The 'STO Disabled' illustration shows this arrangement. If the STO is to be used remove both links.

#### STO Disabled

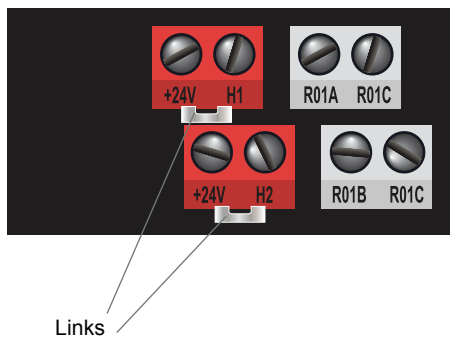

#### STO Enabled

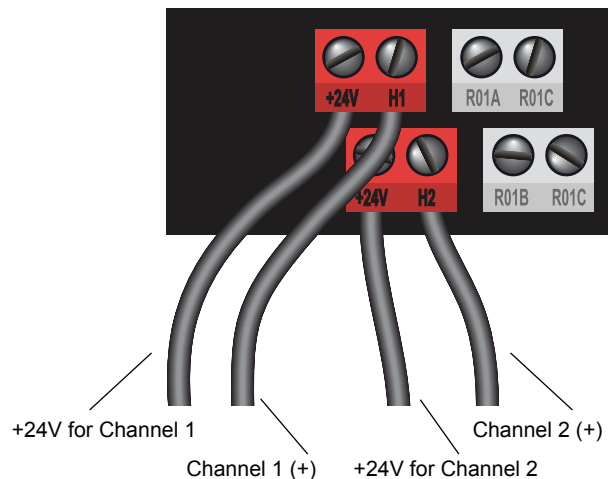

### 15.2 Keypad

When a dual channel safety device is wired to the Inverter and both channels are closed (safe) the Inverter can be operated as normal.

If one or both of the channels open, the Inverter will indicate an STO fault and cannot be operated.

To reset an STO trip, power-cycle the drive.



## 16. How to Reset the Inverter to Factory Defaults



### 16.1 Select Parameter Group P00

With the motor stopped and any fault or alarm messages cleared press the  $\frac{\text{PRG}}{\text{ESC}}$  key to access parameter groups.

Use the  $\blacktriangle$  and  $\blacktriangledown$  keys to select parameter group P00.

Press  $\frac{\text{DATA}}{\text{ENT}}$  to select parameters within this group.



### 16.2 Select Parameter P00.18

Use the  $\blacktriangle$  and  $\blacktriangledown$  keys to select parameter P00.18.

Press  $\frac{\text{DATA}}{\text{ENT}}$  to edit the value.



### 16.3 Set the Value to 1

Use the  $\blacktriangle$  and  $\blacktriangledown$  keys to set the value of P00.18 to 1.

Press  $\frac{\text{DATA}}{\text{ENT}}$  to save the change.

Note: the value of P00.18 will return to 0 when reset is complete.

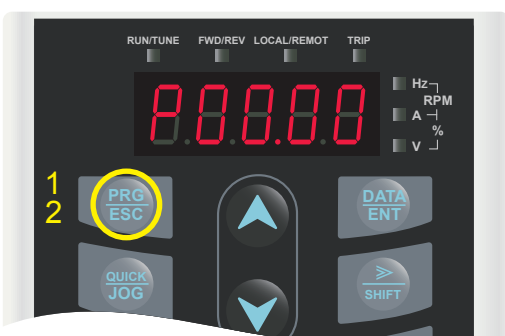

### 16.4 The Inverter Resets

Once the process is complete, P00.00 will be displayed with the last digit flashing.

To return to the main display press  $\frac{\text{PRG}}{\text{ESC}}$  twice.

Note: setting P00.18 to 1 will reset all parameters including motor parameters. To reset without changing motor parameters set P00.18 to 6 instead of 1.