

890

Quickstart Manual

890CS/CD (Common Bus) Drives Frames E & F with STO SIL3/PLe

HA501028U000 Issue 3

1) **What is Safe Torque Off (STO)?**

It is an electronic means of preventing the 890 drive from delivering torque and power to its connected motor. The 890 drive contains this feature as standard. It is a two channel, hardware implemented system. It has the highest possible safety rating for a variable speed drive. It is certified by BGIA, the German Trades Association for Industrial Safety, to Performance Level e (PLe) for a category 3 implementation to EN ISO 13849-1 with an equivalent Safety Integrity Level 3 (SIL 3).

All STO connections are made at terminal block X11.

2) **Where Could STO be Used?**

In safety control schemes for safety ratings up to category 3 PLe or SIL3. To replace expensive but less reliable drive output contactors, including for emergency stop purposes. The 890 STO function can also be used to implement Safe Stop 1 (SS1).

3) **To Use the STO Function - What Should I Do Next?**

Read and observe all the requirements in the STO chapter 6 of the Engineering Reference Manual contained on the supplied CD, use the appropriate standards and risk assessments.

4) **Replacing a NON STO Drive OR the STO Function is Not Required - What Should I Do Next?**

Simply disable the STO function by Linking –

X11/01 and X11/03 to X14/03 (24V) and separately link X11/02 OR X11/04 to X14/04 (0V).

The rest of this quick start manual then applies.

5) **On Start Up the MMI Displays “ ***Tripped*** SAFE TORQUE OFF” or on a 6511 MMI “^ASTO ” . Why?**

Because no connections to X11/01 OR X11/03, they are at 0V, the STO feature has been enabled i.e. failed safe. Simply disable the STO feature by fitting the links described in item 4) above.

© Copyright 2011 Parker Hannifin Manufacturing Limited

All rights strictly reserved. No part of this document may be stored in a retrieval system, or transmitted in any form or by any means to persons not employed by a Parker Hannifin Manufacturing Ltd., without written permission from Parker Hannifin Manufacturing Ltd. Although every effort has been taken to ensure the accuracy of this document it may be necessary, without notice, to make amendments or correct omissions. Parker Hannifin Manufacturing Ltd., cannot accept responsibility for damage, injury, or expenses resulting therefrom.

Contents

	<i>Page</i>
Safety	4
Hazards to Personnel	4
Application Risk	4
• Risk Assessment	5
• Accessibility	5
• Protective Insulation	5
• RCDs	5
Introduction	7
About this QuickStart	7
Overview	8
Installation	9
Mounting Dimensions (890CS)	10
• Ventilation	10
• Environmental Conditions	10
Mounting Dimensions (890CD)	11
890CS Power Connections	12
890CS Control Connections	13
890CD Frame E Power Connections	14
890CD Frame F Power Connections	15
890CD Control Connections	16
890CD Feedback Connections	17
Drive Start-up	18
Before Applying Power:	18
Powering-up the 890CS	19
Powering-up each 890CD	19
890CD Set-up	20
Motor Data	20
Quick Setup Parameters	20
Autotune	21
Running in Local	22
Running in Remote	22
Appendix A: Using the 6511 Keypad	23
The Menu Structure	24
Appendix B: Using the 6901 Keypad	25
The Menu Structure	26
Appendix C: Analog and Digital I/O	27
890CD Control Terminals	28
890CD Control Terminals	29
Appendix D: Electrical Ratings	30
890CS Common Bus Supply	30
890CD Frame E, 400V	31
890CD Frame F, 400V	32
890CD Frame E, 500V	33
890CD Frame F, 500V	34
Appendix E: Compliance	35
EMC Emissions	35
EMC Connections	35
Planning Cable Runs	36

Safety

IMPORTANT Please read this information *BEFORE* installing the equipment.

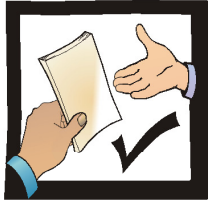

This manual is for anyone installing, operating and servicing this unit.



You must be technically competent to install and operate this unit.

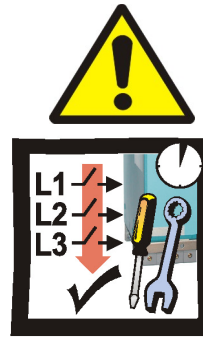

Before working on the unit, isolate the mains supply from terminals L1, L2 and L3 and wait 3 minutes.

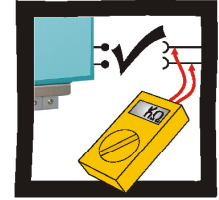

Disconnect the unit from circuits when doing high voltage resistance checks.

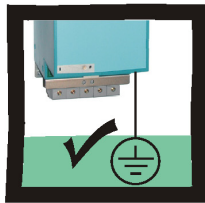

The unit must be **permanently earthed** due to the high earth leakage current.

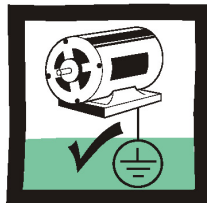

The drive motor must be connected to an appropriate safety earth.



Electrostatic discharge sensitive parts : observe static control precautions.

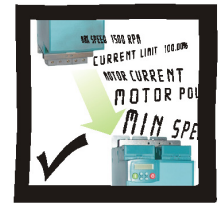

Copy existing 890 parameters to any replacement 890 unit

Hazards to Personnel

This equipment can endanger life through rotating machinery and high voltages. Failure to observe the following will constitute an **ELECTRICAL SHOCK HAZARD**.

Metal parts may reach a temperature of 70 degrees Centigrade in operation.

Before working on the equipment, ensure isolation of the mains supply from terminals L1, L2 and L3. The equipment contains high value capacitors which discharge slowly after removal of the mains supply. Wait for at least 3 minutes for the dc link terminals (DC+ and DC-) to discharge to safe voltage levels (<50V). Measure the DC+ and DC- terminal voltage with a meter to confirm that the voltage is less than 50V.

Do not apply external voltage sources (mains supply or otherwise) to any of the braking terminals (DBR+, DBR-, DC+, INT or EXT).

Application Risk

The specifications, processes and circuitry described herein are for guidance only and may need to be adapted to the user's specific application.

Parker SSD Drives does not guarantee the suitability of the equipment described in the Manual for individual applications.

Risk Assessment

Under fault conditions, power loss or other operating conditions not intended, the equipment may not operate as specified. In particular:

- The motor speed may not be controlled
- The direction of rotation of the motor may not be controlled
- The motor may be energized

If the STO feature of the 890 drive is to be used, the user must undertake a risk assessment for the application. The user must then verify that their design, which includes the 890 drive, satisfies the Performance Level (PL) or Safety Integrity Level (SIL) required by the risk assessment.

Under no circumstances must the STO feature be used without first reading and fully understanding chapter 6 (Safe Torque Off) of the Engineering Reference Manual. All safety warnings therein must be observed.

Accessibility

All live power terminals are IP20 rated only, since the equipment is intended to be installed within a normally-closed cubicle or enclosure, which itself requires a tool to open.

Protective Insulation

- All control and signal terminals are SELV, i.e. protected by double insulation. Ensure all wiring is rated for the highest system voltage.

NOTE *Thermal sensors contained within the motor must be single/basic insulated.*

- All exposed metalwork in the Drive is protected by basic insulation and bonding to a safety earth.

RCDs

Not recommended for use with this product. Where their use is mandatory, use only Type B RCDs (EN61009).

Caution

This is a product of the restricted sales distribution class according to IEC 61800-3. It is designated as “professional equipment” as defined in EN61000-3-2. Permission of the supply authority shall be obtained before connection to the low voltage supply.

Introduction

The 890 Common Bus units are designed for speed control of standard ac 3-phase motors. The common bus scheme consists of one 890CS (Common Bus Supply) and one or more 890CD (Common Bus Drives).

3-phase power is supplied to the 890CS. Power (DC) is bussed from the 890CS to all 890CDs using the DC+ and DC- terminals. A motor is connected to each 890CD unit.

- Control the system remotely using configurable analogue and digital inputs and outputs.
- Control the 890CD locally using the 6901 Keypad.
- Use the Design System Explorer Configuration Tool (DSE 890) to give access to 890CD parameters, diagnostic messages, trip settings and application programming.
- Fit Options to the 890CD to give serial communications and closed loop speed control.

IMPORTANT *Motors used must be suitable for Inverter duty.*

About this QuickStart

This QuickStart will:

- Familiarise you with the terminals and operation of the unit.
- Provide ***basic** installation details and a quick set-up procedure.
- Show you how to Autotune the 890CD and start the motor.

** Because the 890 is a system product and we have no knowledge of your application, we detail the quickest way to power-up the drive using a simple earthing scheme with minimal control wiring. Refer to the full Engineering Reference Manual for items not covered in this QuickStart.*

Provided with every 890 unit is a:

- Quickstart
- Compact disk containing the Engineering Reference Manual and DSE Configuration Tool
- 890 Installation Kit and instruction leaflet
- Keypad
- Customer-ordered Options

This QuickStart assumes that:

- You are a qualified technician with experience of installing this type of equipment.
- You are familiar with the relevant standards and Local Electric Codes (which take precedence).
- You have read and understood the Safety information provided at the front of this QuickStart.
- You realise that this guide contains only basic information and that you may need to refer to the Engineering Reference Manual to complete your installation.
- You are not using the Safe Torque Off (STO) feature of this product and that you will disable it as instructed in this QuickStart manual.
Safety Note – Use of the STO feature requires full compliance with the STO chapter 6 of the Engineering Reference Manual to which the user must first refer.

Overview

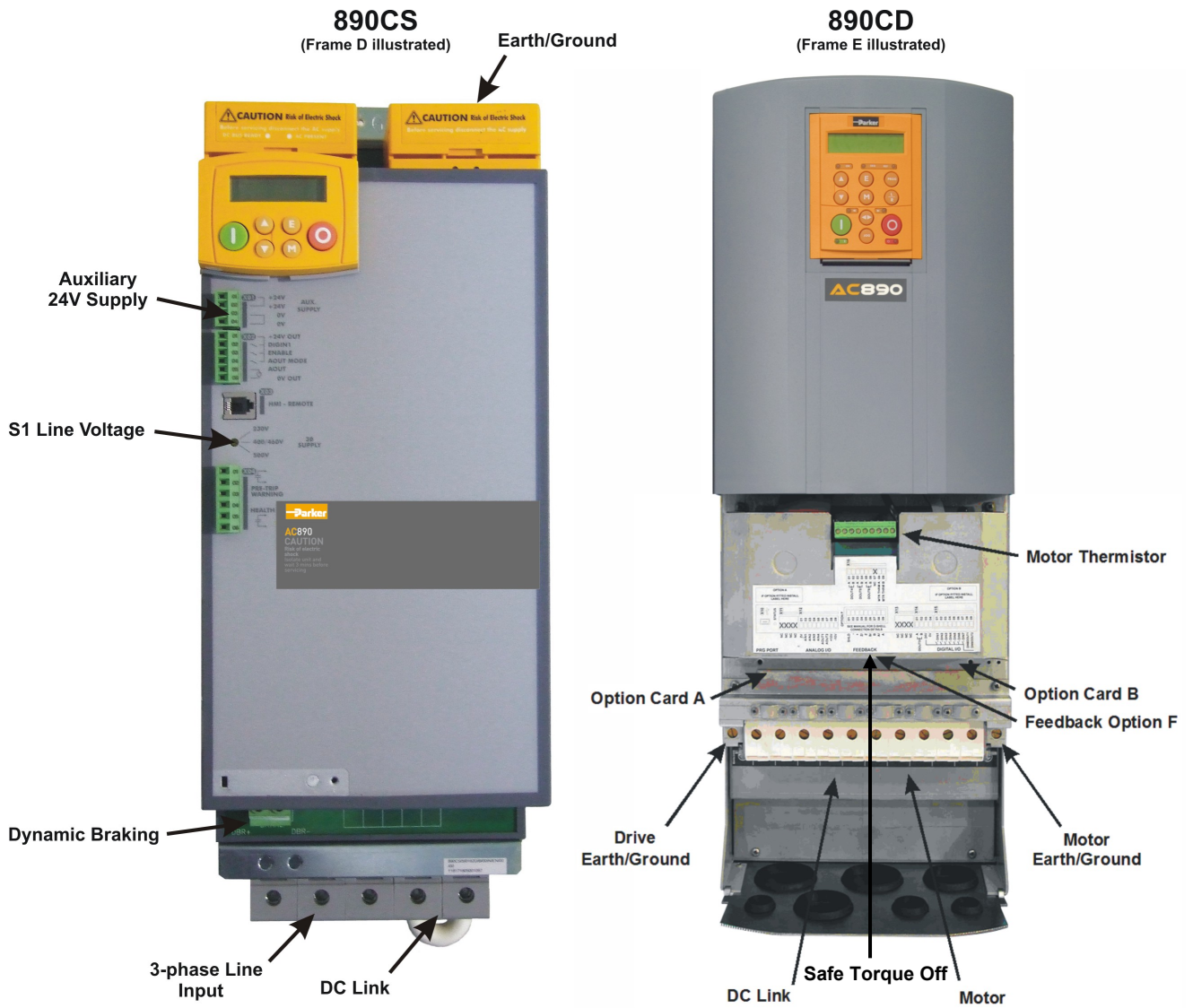

Installation

A simplified installation is shown below. This installation is **not** EMC compliant. For European installations and countries with EMC legislation refer to the 890 Engineering Reference Manual, Appendix C.

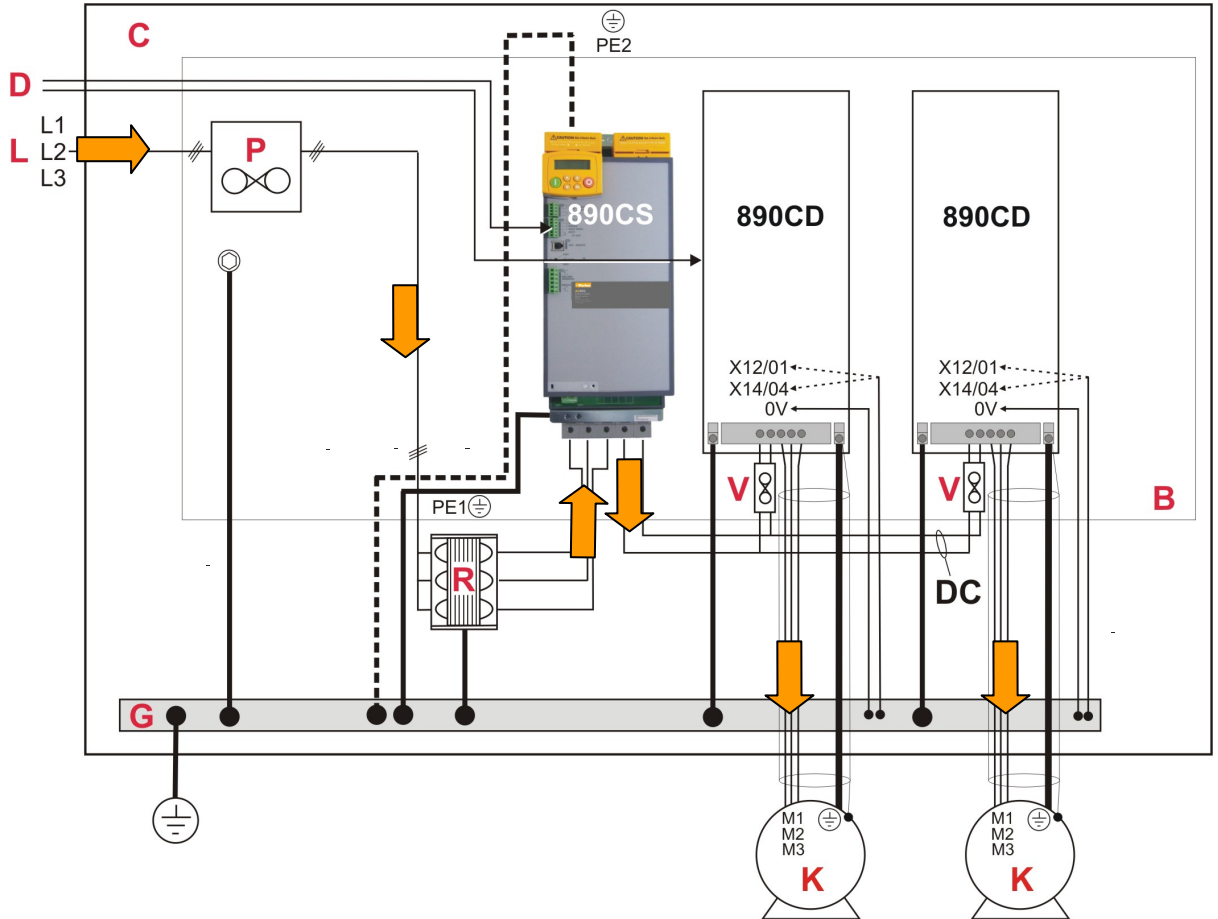

KEY

- B** Back-plate
- C** Cubicle
- D** Control Wiring Terminals
- G** Supply Protective Earth/Ground
- K** Motor (M1, M2, M3)
- L** 3Ø Power Supply Cable (L1, L2, L3)
- P** Fuse or circuit breaker
- R** AC Line Reactor
- V** Fuse

890 Installation Kit

The 890 Installation Kit can be attached to the bottom of the 890CS unit. It can also be fixed to the top of the unit.

The kit provides several options for earth/ground connections. It also includes the brackets for DIN rail mounting the unit. Refer to the instructions in the kit and use the appropriate parts.

* Permanent Earthing

The unit must be **permanently earthed** according to EN 50178: For permanent earthing, one conductor, PE1, of >10mm² cross-section is required; or two individual incoming protective earth conductors, PE1 & PE2, of <10mm² cross-section. Each earth conductor must be suitable for the fault current according to EN 60204.

Mounting Dimensions (890CS)

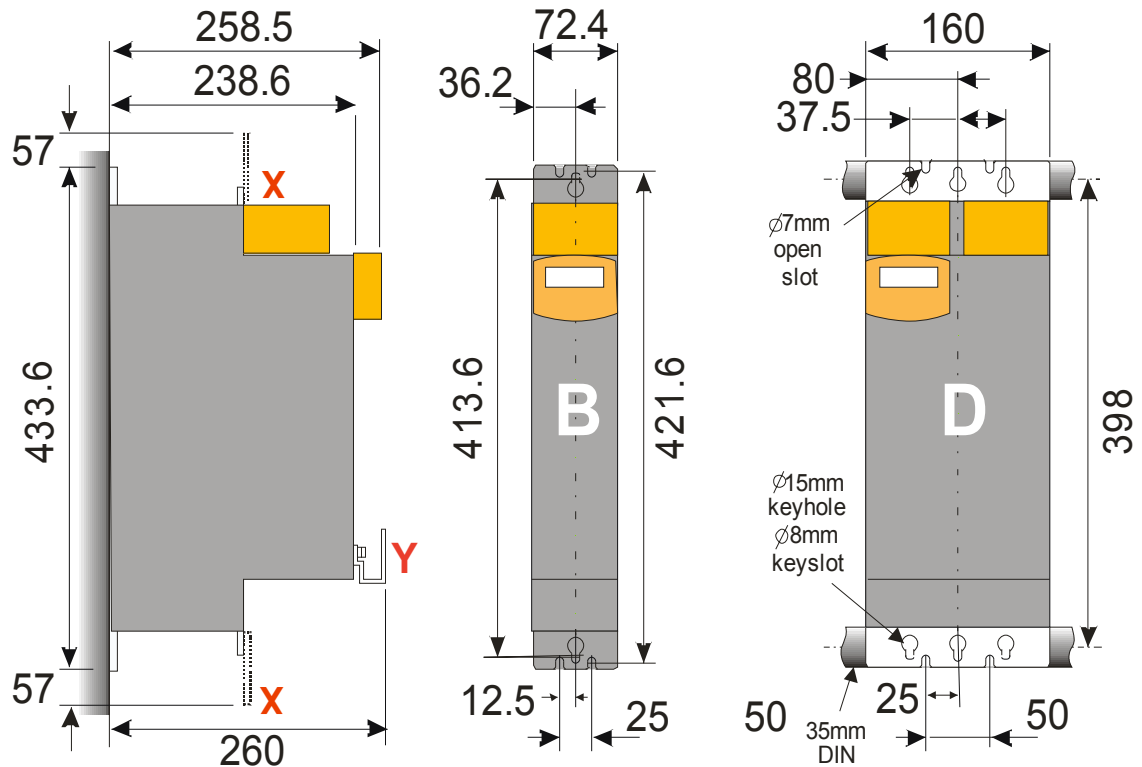

Dimensions are in millimeters (X: Power Bracket - 890 Installation Kit)

The units must be installed in a cubicle. Mount the supply unit using the keyholes and slots or on a 35mm DIN rail using the 890 Installation Kit supplied.

Ventilation

890CS units can be mounted side-by-side with no clearance. A minimum of 150mm (6 inches) free-air space must be allowed at the top and bottom of each unit. If mounting units above or below other equipment, the top and bottom distances should be added for overall clearance between units.

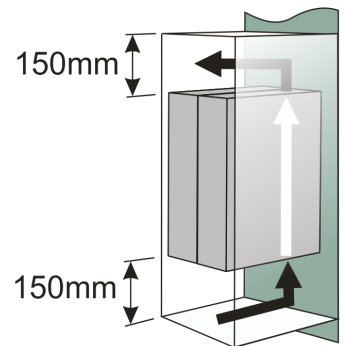

Environmental Conditions

Operating ambient temperature	0°C to 45°C (32°F to 113°F)
Enclosure rating	IP20 – UL(cUL) Open type
Atmosphere	Dust free, non flammable, non-corrosive, <85% humidity, non-condensing

Mounting Dimensions (890CD)

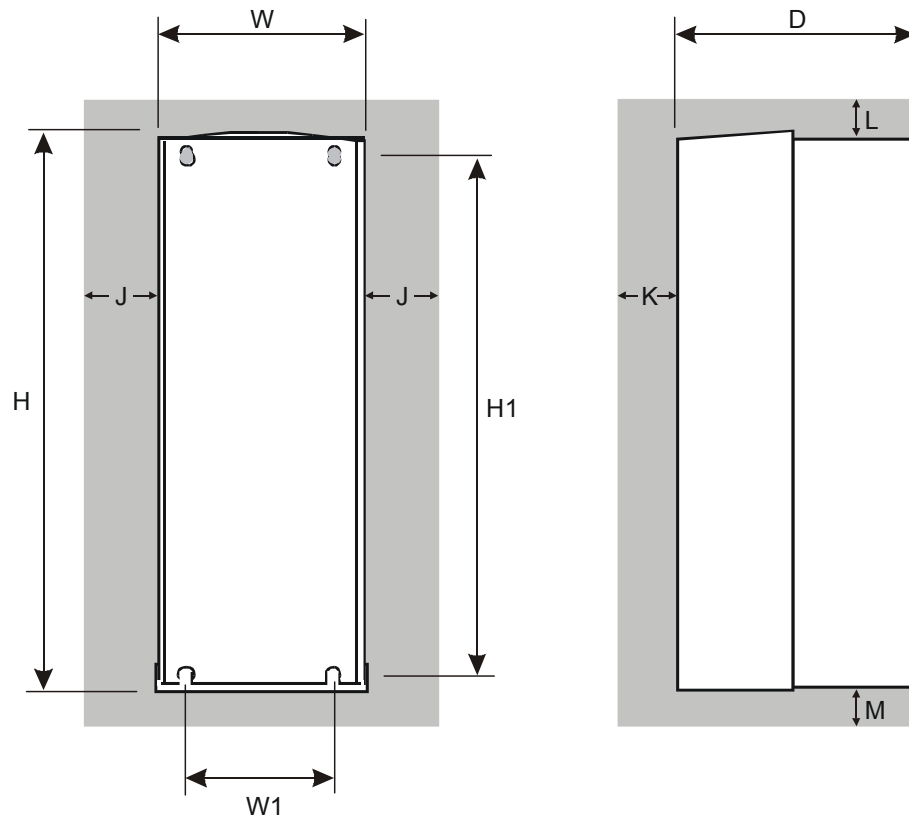

The units must be installed in a cubicle. Mount the drive using the keyholes and slots.

Models	Maximum Weight: kg/lbs	H	H1	W	W1	D	Air Clearance				Fixings
							J	K	L	M	
Frame E	32.5/72	668.6 (26.3)	630.0 (24.8)	257.0 (10.1)	150.0 (5.9)	312 (12.3)	0 (zero)	25 (1)	70 (2.8)	70 (2.8)	Use M6 fixings
Frame F	41/90.4	720.0 (28.3)	700.0 (27.6)	257.0 (10.1)	150.0 (5.9)	355.0 (14.0)	0 (zero)	25 (1)	70 (2.8)	70 (2.8)	Use M6 fixings
All dimensions are in millimeters (inches)											

Ventilation

The drive gives off heat during normal operation. Mount it to allow free flow of air through the ventilation slots and heatsink. The mounting surface must be normally cool. Maintain the minimum air clearances. Clearances are additive when mounting two 890 units together. Ensure heat from adjacent equipment is not transmitted. Maintain the clearance requirements of other equipment.

Environmental Conditions

Operating ambient temperature 0°C to 45°C (32°F to 113°F)
 Enclosure rating IP20 – UL(cUL) Open type

Atmosphere Dust free, non flammable, non-corrosive, <85% humidity,
 non-condensing

890CS Power Connections

1 Connect 3-phase power in any order to L1, L2, L3.

Maximum wire sizes:

- Frame B1: 10mm²/8AWG
- Frame B2: 16mm²/4AWG
- Frame D1: 50mm²/ 1/0AWG
- Frame D2: 95mm²/ 4/0AWG

- A 3% line reactor **MUST** be fitted.
- Use branch circuit protection (circuit breaker and/or fuses)

Refer to Appendix D for Drive rating details

2 Connect the earth/ground wire to the bottom ground bracket.

Maximum wire sizes:

- Frame B1: 10mm²/8AWG
- Frame B2: 16mm²/4AWG
- Frame D1: 50mm²/ 1/0AWG
- Frame D2: 95mm²/ 4/0AWG

3 An External Braking Resistor is optional. Connect it between DBR+ and DBR- for high inertial loads. We recommend using a thermal overload switch to protect the braking circuit.

DO NOT apply external voltage sources (mains supply or otherwise) to the braking terminals.

4 Connect the DC Link wires to the DC+ and DC- terminals.

Maximum wire sizes:

- Frame B1: 10mm²/8AWG
- Frame B2: 25mm²/4AWG
- Frame D1: 70mm²/ 2/0AWG
- Frame D2: 95mm²/ 4/0AWG

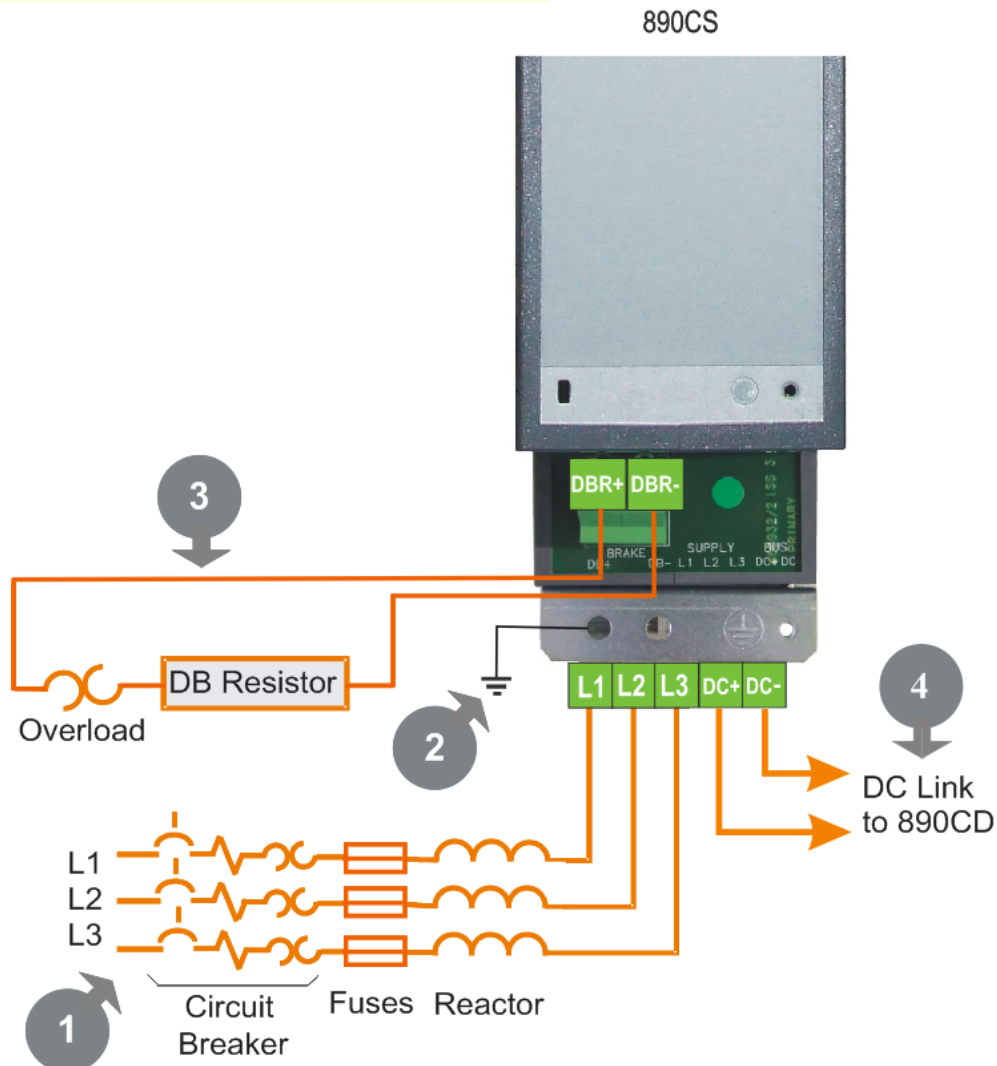

890CS Control Connections

A Voltage Selection

Use a small slotted screwdriver to set the rotary switch S1 to match the voltage of the incoming 3-phase power.

NOTE: This is factory set to 500V. This MUST be set to the incoming line voltage.

B 24V Aux Supply

- Connect a 24VDC power supply across terminals X01/01 and X01/04 (mandatory).
24VDC in terminal X01/01
0VDC in terminal X01/04

C Sequencing

Connect a volt-free contact

- RUN (maintained contact) across terminals X02/01 and X02/03**

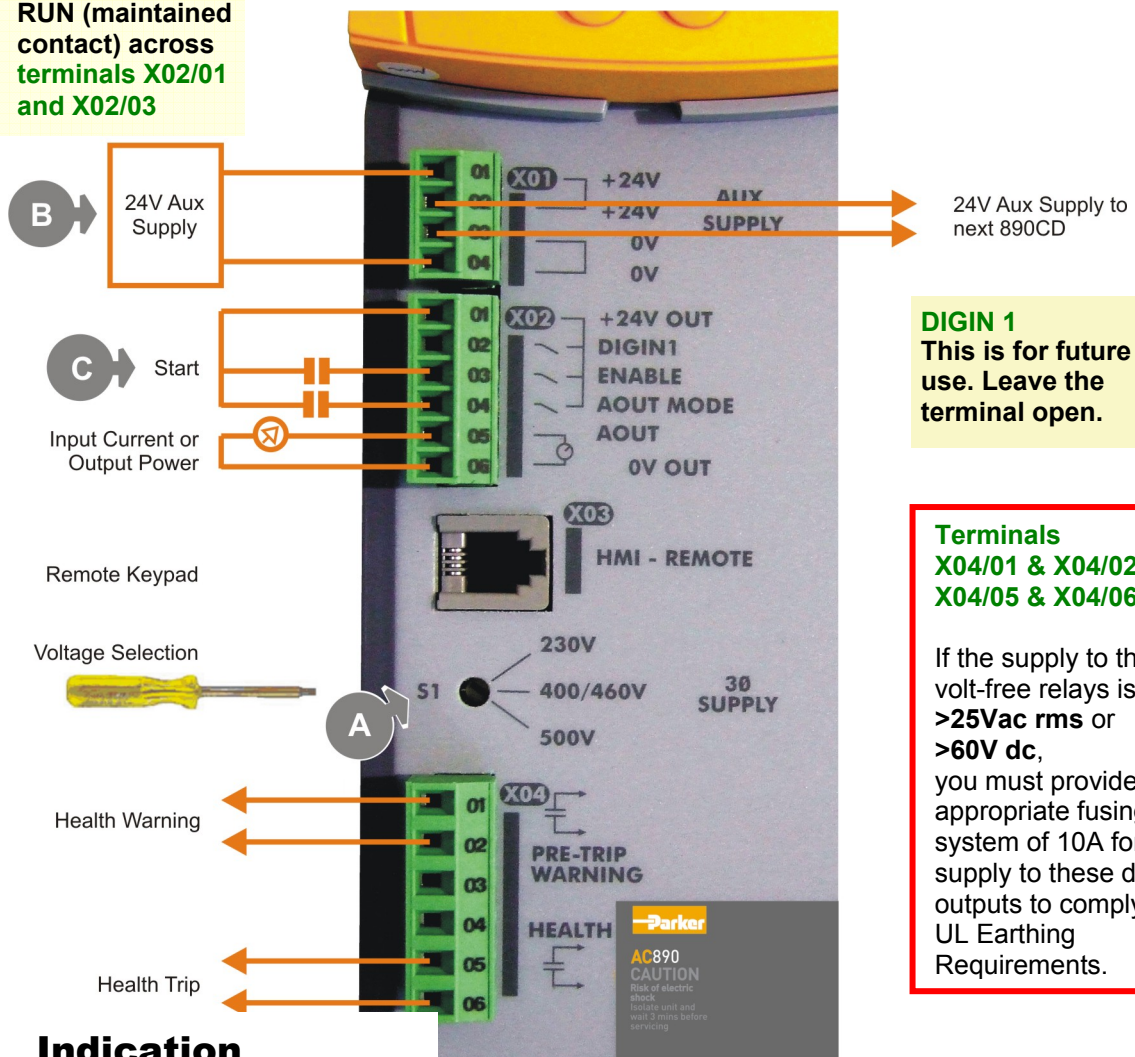

Indication

- Terminals X02/05 and X02/06** provide an analog output proportional to Input Current or Power.
- Terminals X04/01 and X04/02** provide a Health warning contact signalling an impending fault.
- Terminals X04/05 and X04/06** provide a Health Trip contact signalling the drive has faulted.

890CD Frame E Power Connections

5

Connect motor leads to M1/U, M2/V, M3/W.
Maximum wire sizes:

Frame E: 50mm²/1AWG (without crimp)
70mm²/ 1/0AWG (with crimp)

- Connect the earth/ground wire from the terminal box of the motor directly to the earth/ground terminal.

Maximum wire sizes:

Frame E: 50mm²/1AWG (without crimp)
70mm²/ 1/0AWG (with crimp)

- If not using shielded cable, run motor leads in an enclosed metal conduit bonded to the drive at one end and the motor at the other.

6

Connect the earth/ground wire to the earth/ground terminal.

Maximum wire sizes:

Frame E: 50mm²/1AWG (without crimp)
70mm²/ 1/0AWG (with crimp)

7

Connect the DC Link.

Maximum wire sizes:

Frame E: 50mm²/1AWG (without crimp)
70mm²/ 1/0AWG (with crimp)

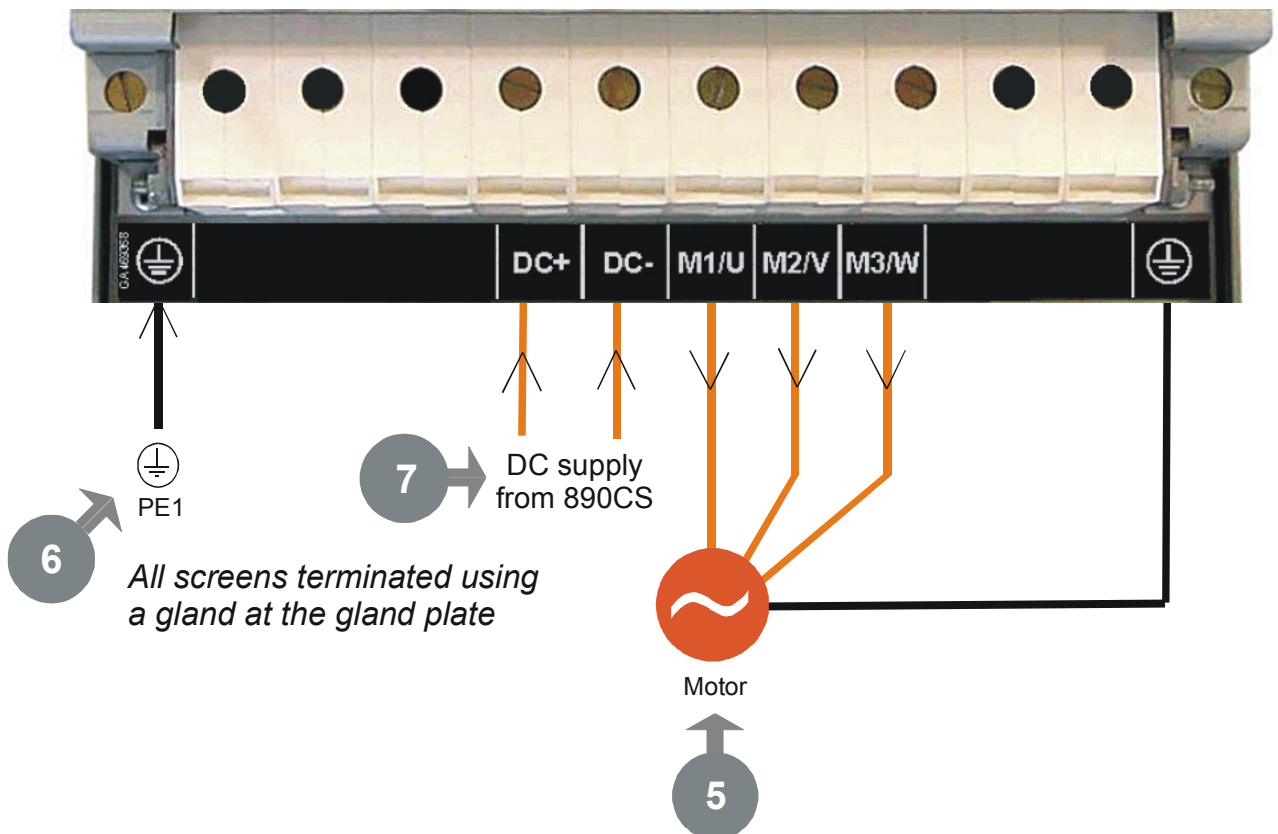

890CD Frame F Power Connections

5

Connect motor leads to M1/U, M2/V, M3/W.
Maximum wire sizes:

Frame F: 95mm²/ 4/0AWG (without crimp)
95mm²/ 4/0AWG (with crimp)

- Connect the earth/ground wire from the terminal box of the motor directly to the earth/ground terminal.

Maximum wire sizes:

Frame F: 95mm²/ 4/0AWG (without crimp)
95mm²/ 4/0AWG (with crimp)

- If not using shielded cable, run motor leads in an enclosed metal conduit bonded to the drive at one end and the motor at the other.

6

Connect the earth/ground wire to the earth/ground terminal.

Maximum wire sizes:

Frame F: 95mm²/ 4/0AWG (without crimp)
95mm²/ 4/0AWG (with crimp)

7

Connect the DC Link.

Maximum wire sizes:

Frame F: 95mm²/ 4/0AWG (without crimp)
95mm²/ 4/0AWG (with crimp)

8

Connect the 115 or 220Vac auxiliary supply for the internal fans to AUX 1 and AUX 2 (in any order).

See block 5 of the Model Number:
1F = 115Vac, 2F = 220Vac.

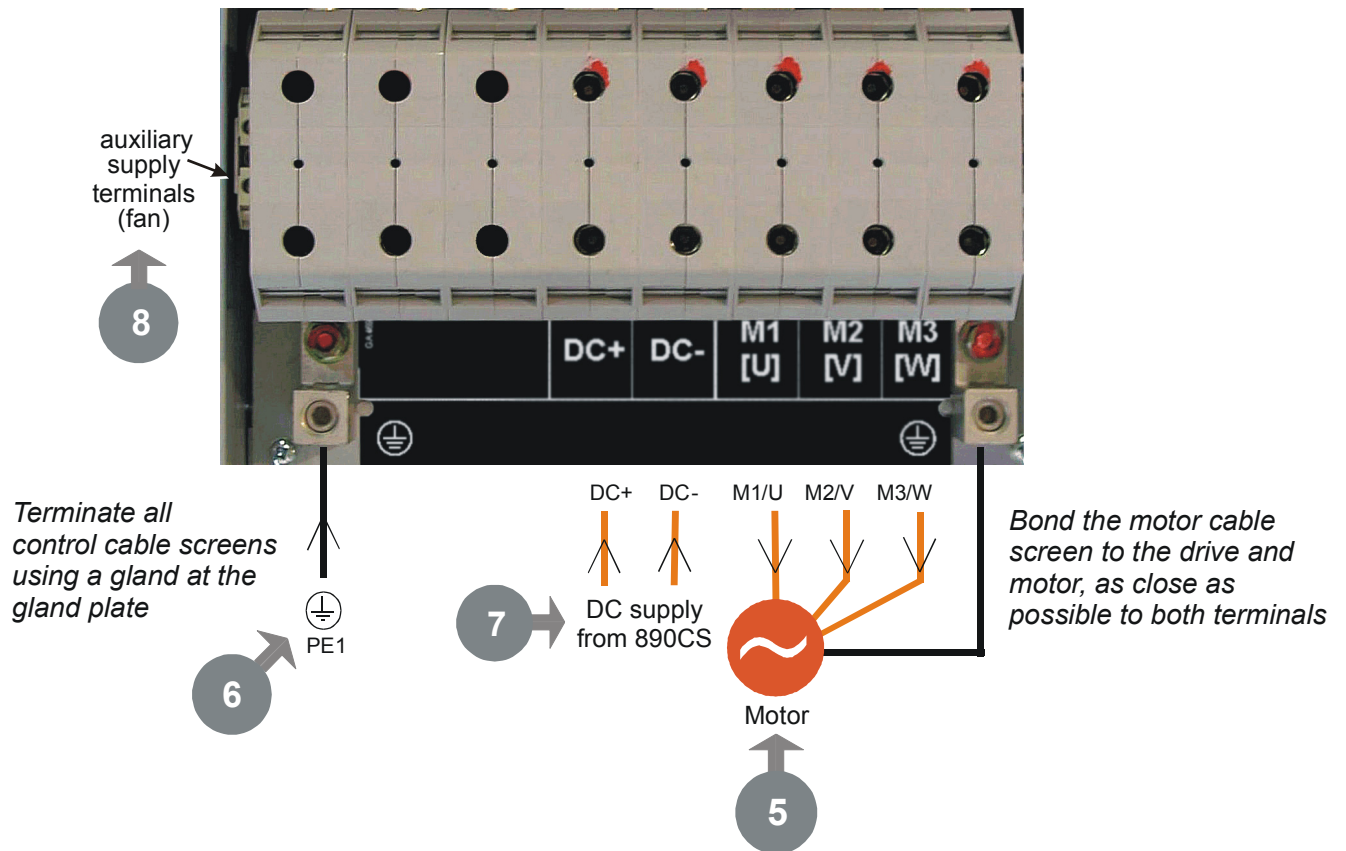

890CD Control Connections

A Speed Reference

- Connect a 10kΩ potentiometer at terminal block X12 (Analog I/P 3)
- High (CW): terminal X12/08
- Wiper: terminal X12/04
- Low (CCW): terminal X12/01
- Connect the shield to earth/ground

OR

- External 2-wire speed reference between terminals X12/01(-) and X12/04(+)
- Connect the shield to earth ground

B Sequencing

- Connect volt-free contacts as required
- RUN (maintained contact) terminal X14/03 and terminal X15/02

C Thermistor

- Connect motor thermal switch or thermistor to terminals X16/08 & X16/09. Drive will trip when the thermal switch opens, or when the thermistor resistance exceeds 4kΩ maximum (PTC Type A : IEC 34-11 Part 2)
- If the motor does not have a protective device (thermistor), jumper these terminals. The drive needs the thermistor inputs connected for it to run.

Analog

- SPEED FEEDBACK
10V = ±100% speed at terminal X12/0 6
- TORQUE FEEDBACK
10V = ±200% torque at terminal X12/07
- ANALOG COMMON
0V at terminal X12/0 1

Digital

- DRIVE HEALTH
Relay dry contact (24V rated) at terminal X14/01 and terminal X14/02
- RUNNING
24V sourcing output at terminal X15/08
- ZERO SPEED
24V sourcing output at terminal X15/09
- DIGITAL COMMON
0V at terminal X14/04

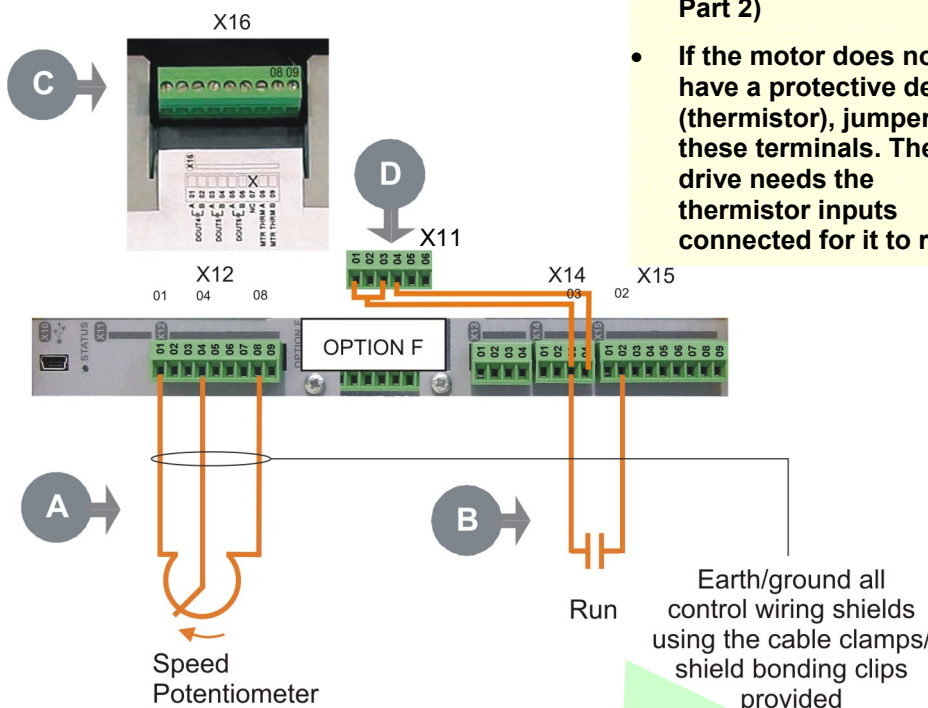

D Safe Torque Off

To disable STO:

- Connect X14/03 to X11/01 and X11/03
- Connect X14/04 to X11/04

To use the STO feature the user must read and fully understand chapter 6 of the Engineering Reference Manual.

The control terminals will accept a single wire of size 1.5mm²/16AWG. For two wires per terminal, use smaller gauge wire such as 0.5mm²/22AWG.

This is a basic connection diagram.
For more detailed information on control connections, refer to Appendix C.

890CD Feedback Connections

This section is only for closed loop vector and induction servo applications. Skip this page if there is no encoder or resolver mounted on the motor.

Incremental Pulse Encoders

The default settings for the drive are for 2048 line, quadrature, incremental pulse encoders with differential outputs operating from a 10VDC supply.

- Z channel (Marker pulse) connections are not necessary for running the drive, but inputs are provided for positioning and servo applications. The supply voltage to the encoder is set in the Quick Setup menu. Range 10 VDC to 20 VDC

Use the Keypad to set the following options:

Supply Voltage - PULSE ENC VOLTS

Number of lines per revolution - ENCODER LINES parameter

* Encoder direction - ENCODER INVERT

** Used to match the encoder direction to the motor direction. When TRUE, changes the sign of the measured speed and the direction of the position count. It is necessary to set up this parameter when in CLOSED-LOOP VEC mode, as the encoder direction must be correct for this mode to operate.*

Using other types of encoders requires the 890 DSE Configuration Tool and the setting of other parameters. Refer to the 890 Engineering Reference Manual for details of these parameters.



OPTION F Terminal Block

- 01 Shield
- 02 Supply -
- 03 Supply +
- 04 Channel Z/
- 05 Channel Z
- 06 Channel B/
- 07 Channel B
- 08 Channel A/
- 09 Channel A

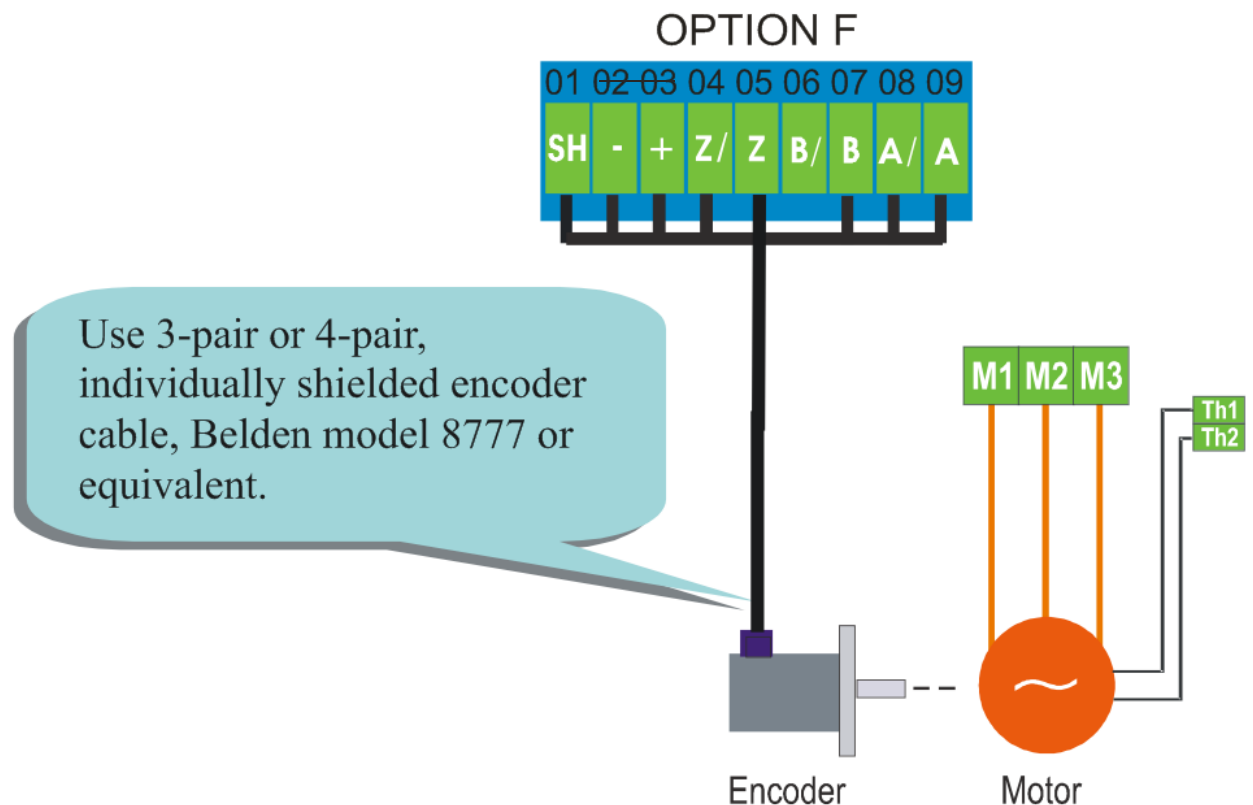

Drive Start-up

Before Applying Power:

- Read the Safety section at the front of the QuickStart.
- Ensure that all local electric codes are met.
- Check for damage to equipment.
- Check for loose ends, clippings, filings, drilling swarf etc. lodged in the drive and system.
- Check all external wiring circuits of the system - power, control, motor and earth connections.
- Ensure that unexpected rotation of the motor in either direction will not result in damage, bodily harm or injury. Disconnect the load from the motor shaft, if possible.
- Check the state of the Motor Thermistor and Brake Resistor connectors. Check external run contacts are open. Check external speed setpoints are all at zero.
- Ensure that nobody is working on another part of the system which will be affected by powering up.
- Ensure that other equipment will not be adversely affected by powering up.
- Check motor stator connections are correctly wired for Star or Delta as necessary for drive output voltage.
- On the 890CS drive, set the line voltage on rotary switch S1.
- Check that the STO feature has been disabled. See page 14 of this Quickstart.
- DANGER: some motors and control methods are not suitable for use with STO. Refer to chapter 6 of the Engineering Reference Manual for full details.

If all connections have been checked, it is time to **POWER-UP the drive**

Powering-up the 890CS

Initial Power-up Sequence

1. **A three-phase supply is NOT necessary at this stage.**
2. Before applying 3-phase power, ensure that an appropriate 3% line reactor has been fitted. This is a pre-requisite of any input section.
3. Ensure ENABLE is low, (0V), X02/03 (connect a temporary switch or remove terminal block).
4. Switch on the 24VDC auxiliary power supply to the 890CS drive.
5. Check the voltage setting on the 890CS keypad (it will appear as soon as you apply power) and ensure it matches your incoming line voltage. If not, switch off the 24VDC, correct the setting of rotary voltage selector switch S1 then switch the 24VDC back on.
6. There are no parameters to set-up the 890CS unit.
7. Check that the run signal on each 890CD is inactive, unless motor rotation is required at this time.
8. **At this stage, apply 3-phase power to the 890CS.** Changing ENABLE to high (24V OUT), will cause the 890CS to power up the DC Link.

Normal Power-up Sequence

The simplest way to power up the 890CS is to connect the ENABLE input to 24V OUT then power up the 3-phase power and the 24VDC auxiliary power supply together. The 890CS will immediately power up the DC Link.

Powering-up each 890CD

1. By now, the whole system has power applied to it.
2. The following sections cover getting the pertinent motor data, setting the appropriate parameters (using the keypad) and performing an autotune.

890CD Set-up

Appendix B contains information about the 6901 keypad menus and parameter names.

Motor Data

Before attempting to set up the drive, you will need some motor information. This is found on the motor nameplate. The information you will need is listed below:

- Base Volts
- Base frequency
- Base RPM
- Full load amps
- No load amps (mag current)
- Connection (star or delta)

Quick Setup Parameters

The following is a list of the Quick Setup parameters you must check before starting the drive. Set only the ones marked with “x” in the table below, under the intended mode of operation.

		<u>V/Hz</u>	<u>SV</u>	<u>Vector</u>
Control Mode	Select the intended operating mode	x	x	x
Max Speed	Motor RPM at full process speed	x	x	x
V/F shape	Usually Linear. Choose fan curve only for fans	x		
Motor Current	Motor full load current from motor nameplate	x	x	x
Motor Base Freq	Motor nameplate frequency	x	x	x
Motor Voltage	Motor nameplate voltage	x	x	x
Nameplate RPM	Motor nameplate RPM	x	x	x
Motor Poles	See Note		x	x
Pulse Enc Volts	Set between 10-20V to match encoder			x
Encoder Lines	Pulses per Revolution of encoder			x
Encoder Invert	Changes polarity of encoder feedback			x
Autotune Enable	Drive will Autotune if started		x	x
Mag Current	Enter the No-Load Amps from the motor nameplate	x	x*	x*

* if performing a Stationary Autotune.

NOTE Some of the parameters are product code dependent, that is, they are different for each frame size and power rating. For example, the unit will be set for either 50Hz or 60Hz operation:

Motor Poles for 60Hz 2 poles = 3600 rpm, 4 poles = 1800 rpm, 6 poles = 1200 rpm
Motor Poles for 50Hz 2 poles = 3000 rpm, 4 poles = 1500 rpm, 6 poles = 1000 rpm

Autotune

This section is only for operating in Sensorless or Closed-loop Vector modes. If the drive is in V/Hz mode, Autotune is unnecessary and does not activate.

- Ensure that MAX SPEED is greater than NAMEPLATE RPM for a successful autotune.
- In the QUICK SETUP menu, set AUTOTUNE ENABLE to TRUE.

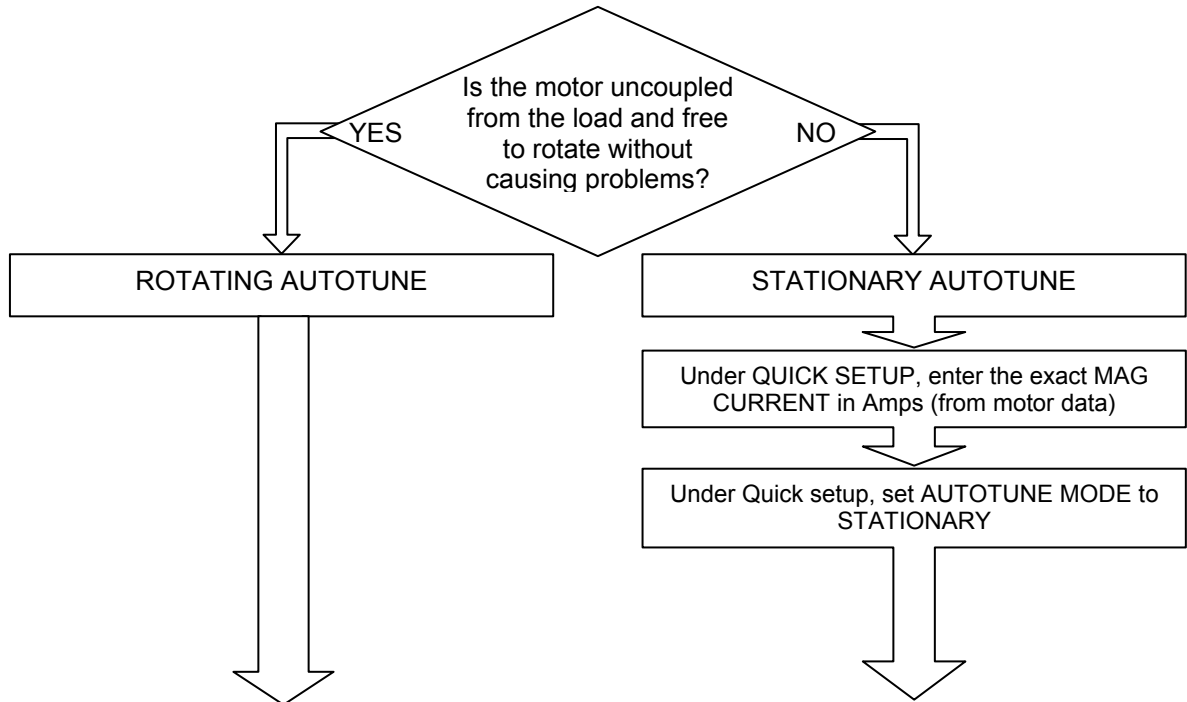

- On the 890CD keypad select LOCAL mode. Set SETPOINT (LOCAL) to 0.0%.
- Press the green RUN button. The drive will begin autotuning. The drive will stop without errors if autotune is successful.
- Go to SYSTEM::SAVE CONFIG::APPLICATION and UP arrow to save your settings.

Running in Local

- On the 890CD keypad select LOCAL mode. The display will show the Local Setpoint : 0.0%
- Use the UP arrow to set a Local Setpoint, say 20%.
- Press the green RUN button. The motor will accelerate to the desired speed and maintain it. Adjust RAMP ACCEL TIME in Quick Setup to the desired level.
- Press the red STOP button. The motor will decelerate to a stop. Adjust RAMP DECEL TIME in Quick Setup to desired level. If the drive trips on Overvoltage, extend the RAMP DECEL TIME or connect a braking resistor. Refer to the 890 Engineering Reference Manual.

Go to SYSTEM::SAVE CONFIG::APPLICATION and UP arrow to save your settings Values are stored during power-down.

Running in Remote

- On the 890CD keypad select REMOTE mode. The display will show the remote Setpoint : ?.?% (The value displayed depends on the external speed reference).
- Dial in a speed setpoint using the Speed potentiometer until the display reads 20%.
- Start the drive by closing the Start contact between terminal X14/03 and terminal X15/02. The motor will accelerate to the desired speed and maintain it. Adjust RAMP ACCEL TIME in Quick Setup to the desired level.
- Open the Start contact. The motor will decelerate to a stop. Adjust RAMP DECEL TIME in Quick Setup to desired level. If the drive trips on Overvoltage, extend the RAMP DECEL TIME or connect a braking resistor. Refer to the 890 Engineering Reference Manual..

Go to SYSTEM::SAVE CONFIG::APPLICATION and UP arrow to save your settings Values are stored during power-down.

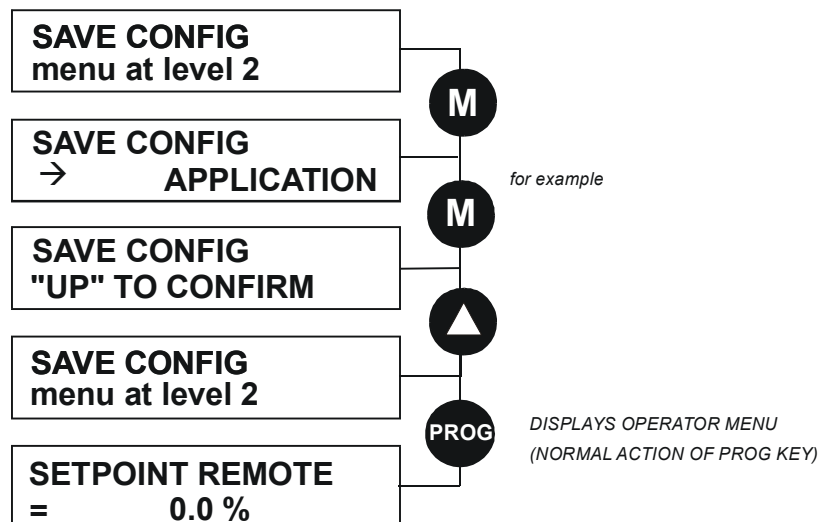

Appendix A: Using the 6511 Keypad





The 6511 is the keypad that comes as standard with the 890CS product. It is a one-line backlit LCD with units and symbols for different functions. It is used as a diagnostic tool.

From power-up, the keypad displays the Software Version, and then times-out to show the Remote Setpoint, as shown opposite.



To change Operating Mode:

On the 890CS you can change between local and remote mode from any point on the MMI.

Mode	Action
Remote to Local	Hold the Stop key  down until LOC is displayed 
Local to Remote	Hold the Stop key  down until LOC and  are removed

To display the software version (890CS):

Press and hold  to display software version.

To display the line voltage rating (890CS):

As above, then press  or  to toggle between software version and line voltage rating.

To Start in Local Mode:

Press 

To Stop in Local Mode:

Press 

Displays diagnostics, parameter and trip information

Displays the units for the value:
S for seconds, **A** for current in Amps, **V** for voltage in Volts, **%** for percentage, **Hz** for frequency in Hertz

Indicates motor shaft direction (890CD), or DC link enabled (890CS)



Indicates Local Mode (Remote Mode when not visible)

The Menu Structure

The main menu for the 890CS is shown below. The unit will initialise in Remote Mode from factory conditions. The Keypad will display the Output Power (%). This is the first of five diagnostics.

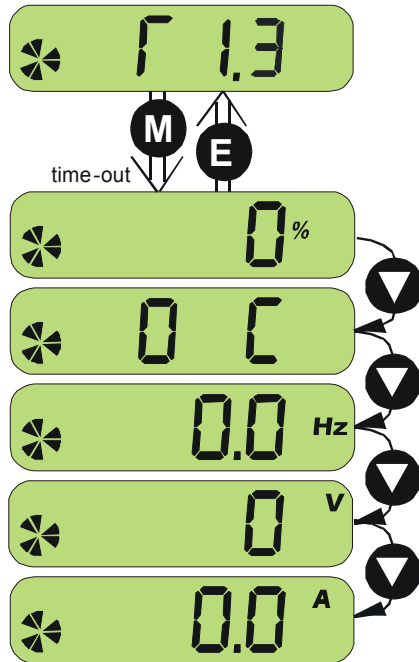

Welcome Screen Displays the software version of the unit

*From the Welcome Screen, the display times-out (alternatively you can press the **M** key) to show the first of 5 diagnostics:*

Output Power As a percentage of nominal full power for the selected input voltage

Heatsink Temp The heatsink temperature in Centigrade

Supply Frequency The real time frequency of the input supply in Hz

DC Link Volts $V_{ac} (rms) \times \sqrt{2} = dc \text{ link Volts}$ (when motor stopped)

Input Current The real time input current in Amps

Appendix B: Using the 6901 Keypad

The 6901 keypad has a two-line backlit LCD display with units and symbols. It can be used to setup and configure the 890 in plain language. It can also be used to operate the drive in Local mode from its Start and Stop buttons, Jog and reverse.

To display the Software Version and Voltage Rating:

Press **E** repeatedly to display the Welcome Screen

Press **M** to return to the Menus

To Start in Local Mode:

Press **I**

To Stop in Local Mode:

Press **O**



SEQ and REF LEDs are On when in Local mode

Menus :	E exit a menu	M sub-menu or parameter	▲ scroll up	▼ scroll down
Parameters :	E exit parameter	M make writable	▲ previous parameter	▼ next parameter
Edit	E stop editing	M show PREF (hold)	▲ increment value	▼ decrement value

To change Operating Mode:

From power-up, the keypad displays the Software Version, and then times-out to show the Remote Setpoint.

Mode	Action
Remote to Local	Toggle between modes using the L/R key L/R SEQ and REF LEDs are On when in Local
Local to Remote	Toggle between modes using the L/R key L/R SEQ and REF LEDs are Off when in Remote

The Menu Structure

The main menus are shown below. Each menu contains parameters.

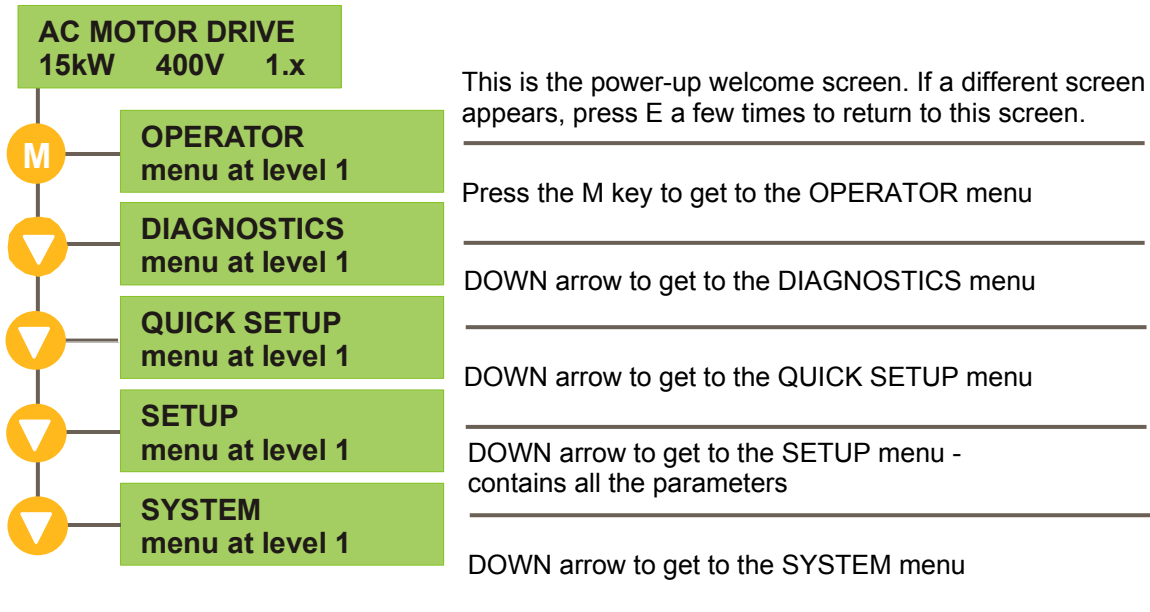

NOTE Refer to the Engineering Reference Manual for a list of available parameters.

Appendix C: Analog and Digital I/O

The terminal function names apply to the factory shipping configuration. These terminals may have different functions if the configuration has been modified using DSE.

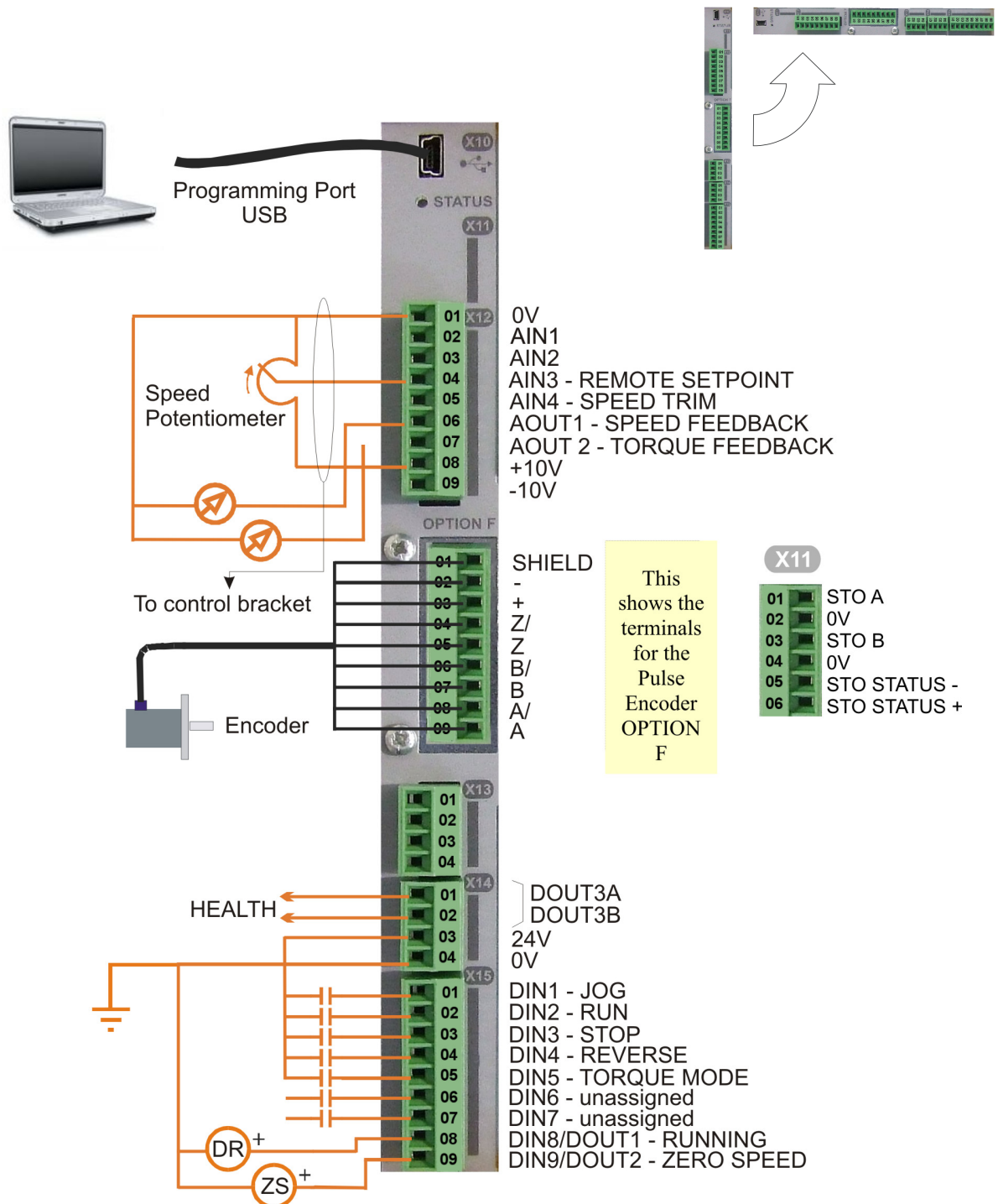

890CD Control Terminals

The terminal function names apply to the factory shipping configuration. These terminals may have different functions if the configuration has been modified using DSE.

- Analog I/O connector is X12
- Analog I/O resolution is 12 bit plus sign
- Digital I/O connector is X15
- Digital I/O is 24VDC, sourced, active high

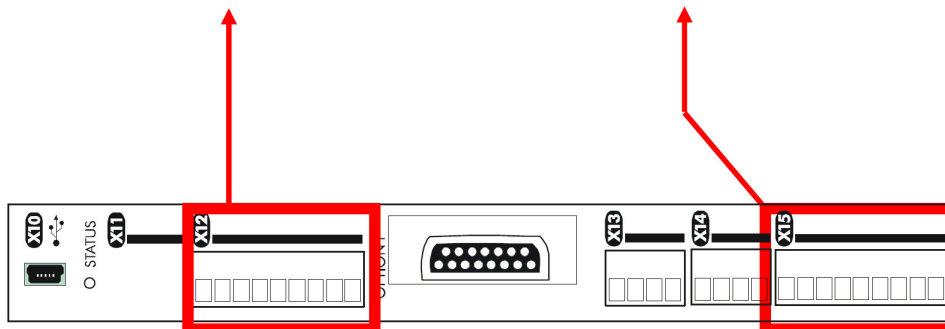

Terminal	Name	Range	Description
ANALOG I/O			
X12/01	0V		0V reference for analog I/O
X12/02	AIN1	0-10V, ±10V	Analog Input 1 Configurable (default = diff I/P +)
X12/03	AIN2	0-10V, ±10V	Analog Input 2 Configurable (default = diff I/P -)
X12/04	AIN3	±10V, 0-10V, 0-20mA, 4-20mA	Analog Input 3 Configurable (default = remote setpoint I/P)
X12/05	AIN4	±10V, 0-10V, 0-20mA, 4-20mA	Analog Input 4 Configurable (default = speed trim I/P)
X12/06	AOUT1	±10V (10V=100%speed)	Analog Output 1 Configurable (default = speed feedback O/P)
X12/07	AOUT2	±10V (10V=200% torque)	Analog Output 2 Configurable (default = torque feedback O/P)
X12/08	+10V REF	+10V	10V reference for analog i/o. Load 10mA maximum
X12/09	-10V REF	-10V	10V reference for analog i/o. Load 10mA maximum
DIGITAL I/O			
X15/01	DIN1	0 or 24V	Configurable Digital Input 1 (default = Jog)
X15/02	DIN2	0 or 24V	Configurable Digital Input 2 (default = Run)
X15/03	DIN3	0 or 24V	Configurable Digital Input 3 (default = Stop)
X15/04	DIN4	0 or 24V	Configurable Digital Input 4 (default = Reverse)
X15/05	DIN5	0 or 24V	Configurable Digital Input 5 (default = Torque mode)
X15/06	DIN6	0 or 24V	Configurable Digital Input 6 (default = Unassigned)
X15/07	DIN7	0 or 24V	Configurable Digital Input 7 (default = Unassigned)
X15/08	DIN8/DOUT1	0 or 24V	Configurable Digital Input/output (default : digital input = Running)
X15/09	DIN9/DOUT2	0 or 24V	Configurable Digital Input/output (default : digital input = Zero Speed)

890CD Control Terminals

Terminal	Name	Range	Description
SAFE TORQUE OFF (STO)			
X11/01	STO A	To disable STO: connect to X14/03	 <p>To use the STO feature, the user must read and fully understand chapter 6 (Safe Torque Off) of the Engineering Reference Manual.</p>
X11/02	STO 0V	To disable STO: do not connect	
X11/03	STO B	To disable STO: connect to X14/03	
X11/04	STO 0V	To disable STO: connect to X14/04	
X11/05	STO STATUS -ve	To disable STO: do not connect	
X11/06	STO STATUS +ve	To disable STO: do not connect	

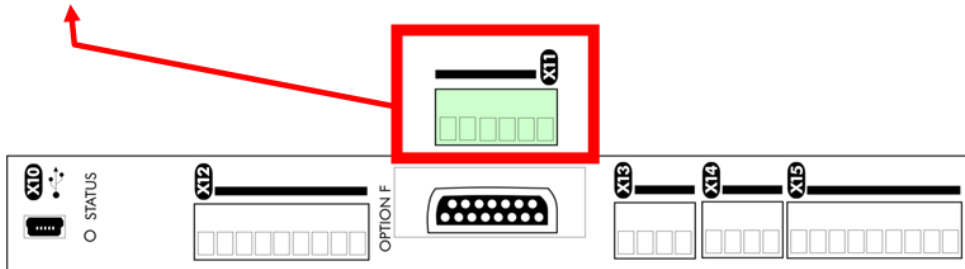

Appendix D: Electrical Ratings

890CS Common Bus Supply

890CS Common Bus Supply			
Output current must not be exceeded under steady state operating conditions. Operating voltage is 208V to 500V ±10%. Output overload 150% overload for 60 seconds. Prospective short circuit current : Frame B 65kA, Frame D 100kA.			
FRAME B : 32A AC rms Input Current (nominal power 15kW)			
Model Number	890CS/5/0032B		
Nominal Operating Voltage	Vac	208/230	380/415
Output Power	7.5kW/10HP	15kW	460
Input Current	A	32	25HP
Continuous RMS Output Current	A	40	
Dynamic Brake Current Rating	A	20	20
			20
FRAME B : 54A AC rms Input Current (nominal power 30kW)			
Model Number	890CS/5/0054B		
Nominal Operating Voltage	Vac	208/230	380/415
Output Power	15kW/20HP	30kW	460
Input Current	A	54	45HP
Continuous RMS Output Current	A	65	
Dynamic Brake Current Rating	A	40	40
			40
FRAME D : 108A AC rms Input Current (nominal power 60kW)			
Model Number	890CS/5/0108D		
Nominal Operating Voltage	Vac	208/230	380/415
Output Power	30kW/40HP	60kW	460
Input Current	A	108	90HP
Continuous RMS Output Current	A	135	
Dynamic Brake Current Rating	A	75	75
			75
FRAME D : 162A AC rms Input Current (nominal power 90kW)			
Model Number	890CS/5/0162D		
Nominal Operating Voltage	Vac	208/230	380/415
Output Power	45kW/60HP	90kW	460
Input Current	A	162	135HP
Continuous RMS Output Current	A	200	
Dynamic Brake Current Rating	A	100	100
			100

890CD Frame E, 400V

890CD Frame E, 400V Power Supply = 380-460V ±10%, 50/60Hz ±5% Motor power, output current and input current must not be exceeded under steady state operating conditions. Input currents listed at 560V DC (from 400Vac 50Hz) for kW ratings and 650V DC (from 460Vac 60Hz) for Hp ratings, assuming a 3% line choke is fitted to the 890CS unit.							
Model Number (Europe)	Catalog Number (North America)	Motor Power	Output Current (A) (note 1)	DC Input Current rms (A)	Heatsink Power Loss (W)	Total Power Loss (W)	Maximum Switching Frequency (kHz)
FRAME E : Prospective short circuit current 65kA.							
Constant Torque (Output Overload Motoring 150% for 60s, 180% for 0.5s short term rating)							
890CD/4/0073E/..		37kW	73	82	546	665	3, 6
	890CD/4/0073E/..	50Hp	73	72	546	665	3, 6
	890CD/4/0087E/..	45kW	87	100	645	645	3, 6
	890CD/4/0087E/..	60Hp	87	87	645	645	3, 6
Quadratic Torque (Output Overload Motoring 110% for 60s)							
	890CD/4/0073E/..	45kW	87	102	667	795	3
	890CD/4/0073E/..	60Hp	87	88	667	795	3
	890CD/4/0087E/..	55kW	105	123	791	939	3
	890CD/4/0087E/..	75Hp	105	107	791	939	3

Note 1: Up to the highest supply voltage that maintains shaft power less than the product power rating, for a typical induction motor. Derated for operation above this supply voltage.

890CD Frame F, 400V

890CD Frame F, 400V Power Supply = 380-460V ±10%, 50/60Hz ±5% Motor power, output current and input current must not be exceeded under steady state operating conditions. Input currents listed at 560V DC (from 400Vac 50Hz) for kW ratings and 650V DC (from 460Vac 60Hz) for Hp ratings, assuming a 3% line choke is fitted to the 890CS unit.							
Model Number (Europe)	Catalog Number (North America)	Motor Power	Output Current (A) (note 1)	DC Input Current rms (A)	Heatsink Power Loss (W)	Total Power Loss (W)	Maximum Switching Frequency (kHz)
FRAME F : Prospective short circuit current 65kA.							
Constant Torque (Output Overload Motoring 150% for 60s, 180% for 0.5s short term rating)							
890CD/4/0105F/..		55kW	105	123	665	965	3
	890CD/4/0105F/..	75Hp	100	107	645	875	3
	890CD/4/0145F/..	75kW	145	166	992	1342	3
	890CD/4/0145F/..	100Hp	130	144	872	1172	3
	890CD/4/0156F/..	90kW	180	203	1190	1650	3
	890CD/4/0156F/..	125Hp	156	176	1040	1480	3
	890CD/4/0180F/..	90kW	180	203	1190	1650	3
	890CD/4/0180F/..	150Hp	180	213	1370	1880	3
Quadratic Torque							
	890CD/4/0105F/..	75kW	145	166	1024	1294	3
	890CD/4/0105F/..	100Hp	125	144	824	1124	3
	890CD/4/0145F/..	90kW	165	203	1172	1542	3
	890CD/4/0145F/..	125Hp	156	176	932	1372	3
	890CD/4/0156F/..	110kW	205	245	1407	1557	3
	890CD/4/0156F/..	150Hp	180	213	1277	1787	3

Note 1: Up to the highest supply voltage that maintains shaft power less than the product power rating, for a typical induction motor. Derated for operation above this supply voltage.

890CD Frame E, 500V

890CD Frame E, 500V

Power Supply = 380-500V ±10%, 50/60Hz ±5%

Motor power, output current and input current must not be exceeded under steady state operating conditions. Input currents listed at 705V DC (from 500Vac 50Hz) for kW ratings, assuming a 3% line choke is fitted to the 890CS unit. 500V unit full power ratings are only available at 500V. The unit can be operated between 380-500V supply voltage with reduced output power below 500V.

Model Number (Europe)	Catalog Number (North America)	Motor Power	Output Current (A) (note 1)	DC Input Current rms (A)	Heatsink Power Loss (W)	Total Power Loss (W)	Maximum Switching Frequency (kHz)
FRAME E : Prospective short circuit current 65kA.							
Constant Torque (Output Overload Motoring 150% for 60s, 180% for 0.5s short term rating)							
890CD/5/0073E/..	-	37kW	67	66	615	727	3, 6
890CD/5/0087E/..	-	45kW	79	80	722	848	3, 6
Quadratic Torque (Output Overload Motoring 110% for 60s)							
890CD/5/0073E/..	-	45kW	79	82	532	660	3
890CD/5/0087E/..	-	55kW	98	98	627	775	3

Note 1: Up to the highest supply voltage that maintains shaft power less than the product power rating, for a typical induction motor. Derated for operation above this supply voltage.

890CD Frame F, 500V

890CD Frame F, 500V

Power Supply = 380-500V ±10%, 50/60Hz ±5%

Motor power, output current and input current must not be exceeded under steady state operating conditions. Input currents listed at 705V DC (from 500Vac 50Hz) for kW ratings, assuming a 3% line choke is fitted to the 890CS unit. 500V unit full power ratings are only available at 500V. The unit can be operated between 380-500V supply voltage with reduced output power below 500V.

Model Number (Europe)	Catalog Number (North America)	Motor Power	Output Current (A) (note 1)	DC Input Current rms (A)	Heatsink Power Loss (W)	Total Power Loss (W)	Maximum Switching Frequency (kHz)
FRAME F : Prospective short circuit current 65kA.							
Constant Torque (Output Overload Motoring 150% for 60s, 180% for 0.5s short term rating)							
890CD/5/0105F/..	-	55kW	100	98	645	875	3
890CD/5/0145F/..	-	75kW	125	133	872	1172	3
890CD/5/0156F/..	-	90kW	156	162	1040	1480	3
Quadratic Torque (Output Overload Motoring 110% for 60s)							
890CD/5/0105F/..	-	75kW	125	133	824	1124	3
890CD/5/0145F/..	-	90kW	156	162	932	1372	3

Note 1: Up to the highest supply voltage that maintains shaft power less than the product power rating, for a typical induction motor. Derated for operation above this supply voltage.

Appendix E: Compliance

A comprehensive guide to product compliance is available in the full product manual.

Warning Where there is a conflict between EMC and safety requirements personnel safety shall always take precedence.

Operation of this equipment requires detailed installation and operation instructions provided in the installation/operation manual intended for use on this product. This information is provided on the CD ROM included in the container this device was packaged in. It should be retained with this device at all times.

Caution: This is a product of the restricted sales distribution class according to IEC 61800-3. It is designated as “professional equipment” as defined in EN61000-3. Permission of the supply authority shall be obtained before connection to the low voltage supply.

In a domestic environment this product may cause radio interference in which case supplementary mitigation measures may be required.

This equipment contains electrostatic discharge (ESD) sensitive parts. Observe static control precautions when handling, installing and servicing this product.

EMC Emissions

Radiated Emissions comply with EN61800-3 category C1, C2 and C3 when installed in accordance with instructions in Chapter 4 / 5 refer to “mounting the unit”.

Conducted Emissions comply with EN61800-3 category C3 without external filter and category C1 and C2 when fitted with specified external filter.

Immunity complies with the requirement of EN61800-3, for equipment intended for use in the second environment.

EMC Connections

For compliance with the EMC requirements, the “0V/signal ground” is to be separately earthed. When a number of units are used in a system, these terminals should be connected together at a single, local earthing point.

Control and signal connections should be made with screened cables, with the screen connected only at the VSD end. However, if high frequency noise is still a problem, earth screen at the non VSD end via a 0.1µF capacitor.

Note: Connect the control and signal screens (at the VSD end) to the VSD protective earth point, and not to the control board terminals.

Motor cables should have a 360° bond to ensure a low impedance connection, as per the figure below;

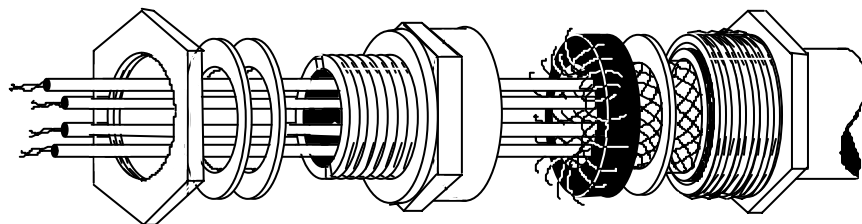

Planning Cable Runs

- ◆ Use the shortest possible motor cable lengths.
- ◆ Use a single length of cable to a star junction point to feed multiple motors.
- ◆ Keep electrically noisy and sensitive cables apart. If this is not possible parallel cable runs should be separated by at least 0.25 meters, for runs longer than 10 meters, separation should be increased proportionally.
- ◆ Sensitive cables should cross noisy cables at 90°.
- ◆ Never run sensitive cables close or parallel to the motor, dc link and braking chopper circuit for any distance.
- ◆ Never run supply, dc link or motor cables in the same bundle as the signal/control and feedback cables, even if they are screened.
- ◆ Ensure EMC filter input and output cables are separately routed and do not couple across the filter.

