

# ACS480 drives

## Quick installation and start-up guide



### Safety instructions

Read the safety instructions in the *ACS480 Hardware manual* (3AXD50000047392 [EN]).

**WARNING!** Obey these safety instructions to prevent physical injury or death, or damage to the equipment. If you are not a qualified electrician, do not do electrical installation or maintenance work.

- Keep the drive in its package until you install it. After unpacking, protect the drive from dust, debris and moisture.
- Use the required personal protective equipment: safety shoes with metal toe cap, safety glasses, protective gloves, etc.
- Disconnect all possible voltage sources. Lock and tag.
- When the drive or connected equipment is energized, do not do work on the drive, motor cable, motor, control cables or control circuits.
- After you disconnect the input power, wait for five minutes to let the DC bus capacitors discharge. Measure and make sure that the,
  - DC voltage between the DC bus terminals (UDC+, UDC-, R-) is 0 V.
  - DC voltage between the DC bus terminals (UDC+, UDC-, R-) and ground (PE) is 0V.
- Make sure that the equipment is not energized. Use a multimeter with an impedance of at least 1 Mohm. Make sure that the,
  - voltage between the drive input power terminals (L1, L2, L3) and the ground (PE) is 0 V.
  - phase to phase voltage between the drive input power terminals (L1, L2, L3) is 0 V.
  - voltage between the drive output terminals (T1/U, T2/V, T3/W) and the ground (PE) is 0 V.
  - phase to phase voltage between drive output terminals (T1/U, T2/V, T3/W) is 0 V AC.
- If you use a permanent magnet synchronous motor, do not do work on the drive when the motor rotates. A permanent magnet motor that rotates energizes the drive and the input power terminals.

**WARNING!** The installation, start-up and operation of this equipment requires detailed instructions. Refer to the detailed instructions in the *ACS480 Hardware manual* (3AXD50000047392 [EN]) and *ACS480 Firmware manual* (3AXD50000047399 [EN]). You can download these manuals from the ABB website or order hard copies of the manuals with the delivery. Keep this guide near the unit at all times.

### 1. Examine the installation area

The drive is intended for cabinet installation and has a degree of protection of IP20 / UL open type.

Make sure that in the installation area:

- There is sufficient cooling and hot air does not recirculate.
- There is sufficient space above and below the drive for cooling. Refer to *Free space requirements*.
- The ambient conditions are suitable. Refer to *Ambient conditions*.
- The mounting surface is non-flammable and can hold the weight of the drive. Refer to *Dimensions and weights*.
- Materials near the drive are non-flammable.

### 2. Install the drive

You can install the drive with screws or to a DIN rail [Top Hat, W x H = 35 x 7.5 mm (1.4 x 0.3 in)].

Installation requirements:

- Make sure that there is a minimum of 75 mm (2.9 in) of free space at the top and bottom of the drive for cooling air.
- You can install the R1, R2, R3 and R4 drives tilted by up to 90 degrees, from vertical to fully horizontal orientation.
- You can install several drives side by side. Side-mounted options require approximately 20 mm (0.8 in) of space on the right side of the drive.

**WARNING!** Do not install the drive upside down. Make sure that the cooling air exhaust (at the top) is always above the cooling air inlet (at the bottom).

#### To install the drive with screws

- Make marks onto the surface for the mounting holes. Refer to *Dimensions and weights*. The R3 and R4 drives come with a mounting template.
- Make the holes for the mounting screws and install suitable plugs or anchors.
- Start to tighten the screws into the mounting holes.

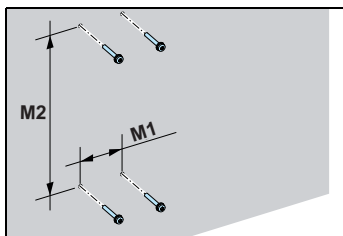

- Install the drive onto the mounting screws.
- Tighten the mounting screws.

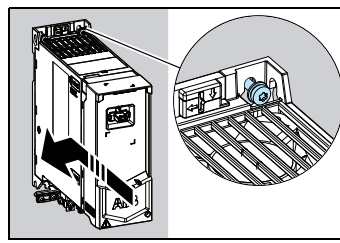

#### To install the drive to a DIN rail

- Move the locking part to the left.
- Push and hold the locking button down.
- Put the top tabs of the drive onto the top edge of the DIN installation rail.
- Put the drive against the bottom edge of the DIN installation rail.
- Release the locking button.
- Move the locking part to the right.
- Make sure that the drive is correctly installed.
- To remove the drive, use a flat-head screwdriver to open the locking part.

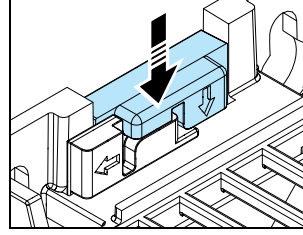
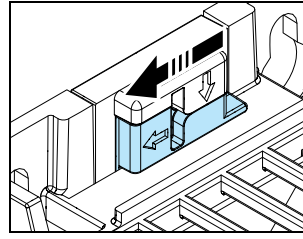

### 3. Measure the insulation resistance

**Drive:** Do not do voltage tolerance or insulation resistance tests on the drive, because this can cause damage to the drive.

**Input power cable:** Before you connect the input power cable, measure the insulation of the input power cable. Obey the local regulations.

**Motor and motor cable:**

- Make sure that the motor cable is connected to the motor and disconnected from the drive output terminals T1/U, T2/V and T3/W.
- Use a voltage of 1000 V DC to measure the insulation resistance between each phase conductor and the protective earth conductor. The insulation resistance of an ABB motor must be more than 100 Mohm (at 25 °C/77 °F). For the insulation resistance of other motors, refer to the manufacturer's documentation. Moisture in the motor decreases the insulation resistance. If you think that there is moisture in the motor, dry the motor and do the measurement again.

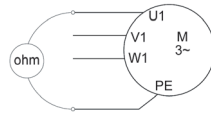

### 4. Select the cables

See the drive hardware manual for the cable selection instructions.

**Note:**

**Input power cable:** IEC/EN 61800-5-1 requires two protective earth (ground) conductors.

**Motor cable:** ABB recommends to use symmetrical shielded cable (VFD cable) for the best EMC performance.

**Control cable:** Use a double-shielded twisted-pair cable for the analog signals. Use a double- or single-shielded cable for the digital, relay and I/O signals. Do not mix 24 V and 115/230 V signals in the same cable.

### 5. Connect the power cables

#### Connection diagram (shielded cables)

If you do wiring in conduits, see the drive hardware manual for more information.

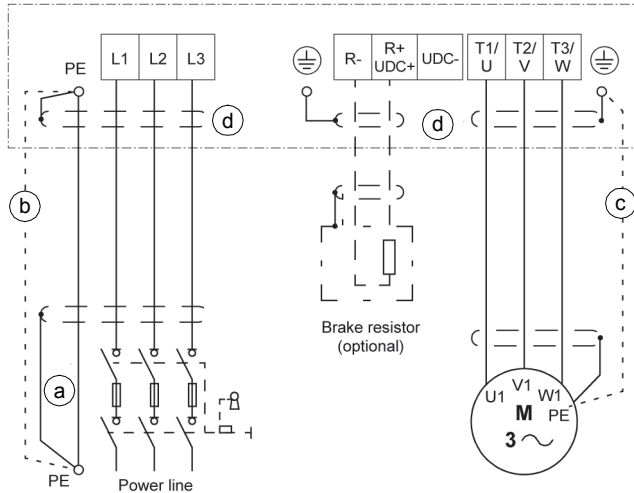

- Two grounding conductors. Use two conductors, if the cross-section of the grounding conductor is less than 10 mm<sup>2</sup> Cu (8 AWG) or 16 mm<sup>2</sup> Al (6 AWG) (IEC/EN 61800-5-1). For example, use the cable shield in addition to the fourth conductor.
- Separate grounding cable (line side). Use it if the conductivity of the fourth conductor or shield is not sufficient for the protective grounding.
- Separate grounding cable (motor side). Use it if the conductivity of the shield is not sufficient for the protective grounding, or there is no symmetrically constructed grounding conductor in the cable.
- 360-degree grounding of the cable shield. This is required for the motor cable and brake resistor cable, and recommended for the input power cable.

#### Connection procedure (shielded cables)

If you do wiring in conduits, see the drive hardware manual for more information.

**WARNING!** Obey the safety instructions in the *ACS480 Hardware manual* (3AXD50000047392 [EN]). If you ignore them, injury or death, or damage to the equipment can occur.

**WARNING!** Make sure that the drive is compatible with the power supply system. You can connect all drive types to a symmetrically grounded TN-S system. You can also connect the UL (NEC) drive types to a corner-grounded system. For other power supply systems, you may need to disconnect the EMC filter or the ground-to-phase varistor. For more information, see the drive hardware manual.

- Open the front cover. To open the front cover, loosen the locking screw and lift the front cover up.
- Strip the motor cable.
- Ground the motor cable shield under the grounding clamp.
- Twist the motor cable shield into a bundle, mark it accordingly and connect it to the grounding terminal.
- Connect the phase conductors of the motor cable to the T1/U, T2/V and T3/W motor terminals. Torque the terminals to 0.8 N-m (7 lbf-in).

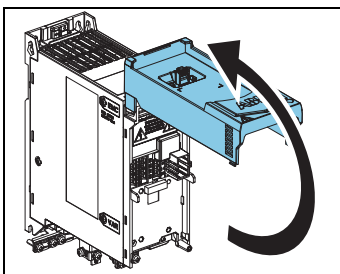

- If applicable, connect the brake resistor cable to the R- and UDC+ terminals. Torque the terminals to 0.8 N-m (7 lbf-in). Use a shielded cable and ground the shield under the grounding clamp.
- Strip the input power cable.
- If the input power cable has a shield, twist it into a bundle, mark it and connect it to the grounding terminal.
- Connect the PE conductor of the input power cable to the grounding terminal. If it is necessary, use a second PE conductor.
- Connect the phase conductors of the input power cable to the L1, L2 and L3 input terminals. Torque the terminals to 0.8 N-m (7 lbf-in).
- Mechanically attach the cables on the outside of the drive.

**Note!** If you power up the drive before you install the I/O or fieldbus module, the drive gives a warning.

### 6. Install the communication module

To install the communication module (I/O module or fieldbus module):

- Open the front cover.
- Align the communication module contacts with the contacts on the drive.
- Carefully push the communication module into position.
- Push the locking tab in.
- Tighten the locking screw to fully attach and electrically ground the communication module.

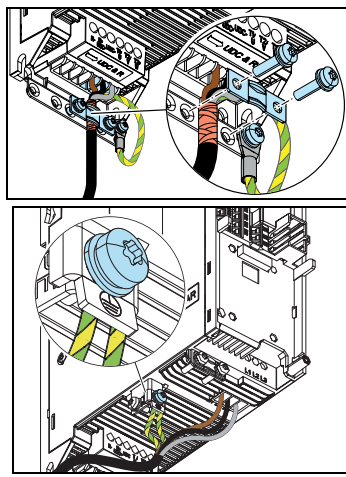

### 7. Connect the control cables

#### Connection procedure

Do the connections according to the default control connections of the application macro that you select. For the connections of the factory default macro (ABB standard macro), refer to *Default I/O connections (ABB standard macro)*. For the other macros, refer to the *ACS480 Firmware manual* (3AXD50000047399 [EN]).

**Note:**

- If you do not use the I/O module, select the ABB limited macro.
- This is an IEC compliant connection procedure. For the UL(NEC) connection, see the HW manual.

Keep the signal wire pairs twisted as near to the terminals as possible to prevent inductive coupling.

- Strip a part of the outer shield of the control cable for grounding.
- Use a cable tie to ground the outer shield to the grounding tab.
- Strip the control cable conductors.
- Connect the conductors to the correct control terminals. Torque the terminals to 0.5 N-m (4 lbf-in).
- Connect the shields of the twisted pairs and grounding wires to the SCR terminal. Torque the terminals to 0.5 N-m (4 lbf-in).
- Mechanically attach the control cables on the outside of the drive.
- Close the front cover and tighten the locking screw.

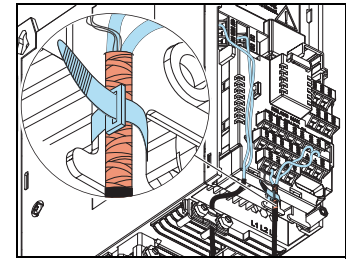

#### Default I/O connections (ABB standard macro)

Terminal	Description	Base unit
<b>Reference voltage and analog I/O</b>		
SCR	Signal cable shield (screen)	
AI1	Output freq./speed ref: 0...10 V	
AGND	Analog input circuit common	
+10 V	Reference voltage 10 V DC	
AI2	Not configured	
AGND	Analog input circuit common	
AO1	Output frequency: 0...20 mA	
AO2	Output current: 0...20 mA	
AGND	Analog output circuit common	
<b>Aux. voltage output and programmable digital inputs</b>		
+24 V	Aux. voltage output +24 V DC, max. 250 mA	×
DGND	Aux. voltage output common	×
DCOM	Digital input common for all	×
DI1	Stop (0)/Start (1)	×
DI2	Forward (0)/Reverse (1)	×
DI3	Constant frequency/speed selection	
DI4	Constant frequency/speed selection	
DI5	Ramp set 1 (0)/Ramp set 2 (1)	
DI6	Not configured	
<b>Relay outputs</b>		
RO1C	Ready	×
RO1A	250 V AC/30 V DC	×
RO1B	2 A	×
RO2C	Running	
RO2A	250 V AC/30 V DC	
RO2B	2 A	
RO3C	Fault (-1)	
RO3A	250 V AC/30 V DC	
RO3B	2 A	
<b>EIA-485 Modbus RTU</b>		
B+	Embedded Modbus RTU (EIA-485)	
A-		
DGND		
TERM&BIAS	Serial data link termination switch	
<b>Safe torque off</b>		
SGND	Safe torque off. Factory connection. Both circuits must be closed for the drive to start.	×
IN1		×
IN2		×
OUT1		×
<b>Auxiliary voltage output</b>		
+24V	Auxiliary voltage output. The alternative terminals have the same supply as the base unit.	
DGND		
DCOM		

**Note:** × refers to terminals in the base unit. Other terminals are in the RIIO-01 I/O extension module (installed in the standard drive variant as default).

## Connecting EIA-485 Modbus RTU terminal to the drive

Connect the fieldbus to the EIA-485 Modbus RTU terminal on the RII0-01 module which is attached to the control unit of the drive. The connection diagram is shown below.

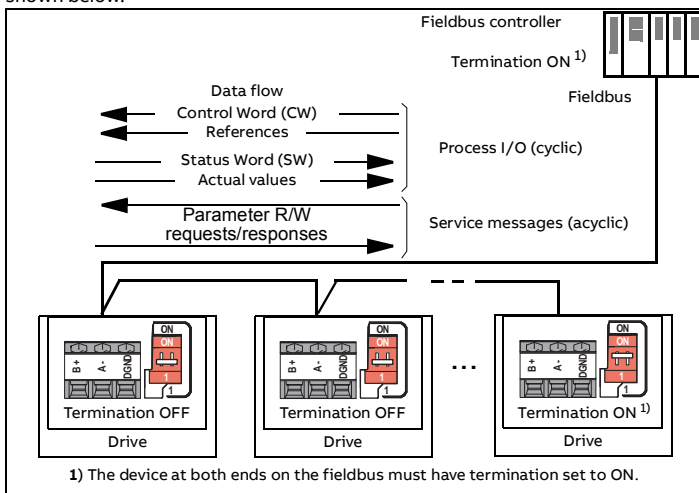

1) The device at both ends on the fieldbus must have termination set to ON.

## 8. Install the control panel

To install the control panel:

1. Close the front cover and tighten the locking screw.
2. Put the bottom edge of the control panel into position.
3. Push the top of the control panel until it locks into position.

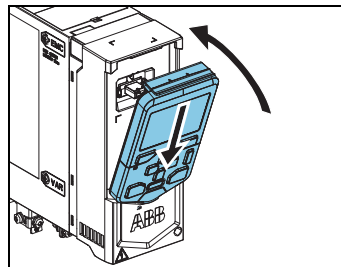

## 9. Start up the drive

For information on the start-up and drive parameters, refer to the *ACS480 Firmware manual* (3AXD50000047399 [EN]).

**WARNING!** Before you start up the drive, make sure that the installation is complete. Make sure that the cover of the drive and the cable box, if included, are in place. Make sure that the motor does not cause danger when it starts. Disconnect the motor from other machinery, if there is a risk of damage or injury.

For information on the user interface, refer to the *ACS-AP-x Assistant control panel user's manual* (3AUA0000085685 [EN]).

The control panel has softkeys below the display to access the corresponding commands, and arrow keys to navigate the menu and change parameter values. Push the "?" button to open the help function.

First start-up:

Make sure that you have the motor data (from the name plate) available.

1. Set the main power to on.

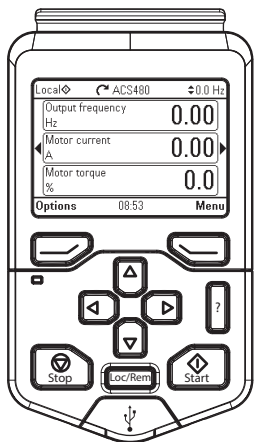

2. Select the user interface language with the arrow keys and set it with the right softkey (OK).



3. Select *Start set-up* and push the right softkey (Next).

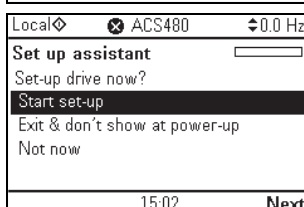

4. Select the localization and push the right softkey (Next).

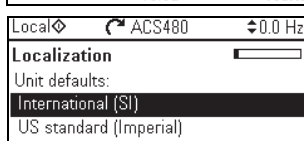

To set up fieldbus communications for a fieldbus adapter, refer to the applicable fieldbus adapter manual and to the *ACS480 Firmware manual* (3AXD50000047399 [EN]).

You can also use *Primary settings* in the Main menu to configure the unit.

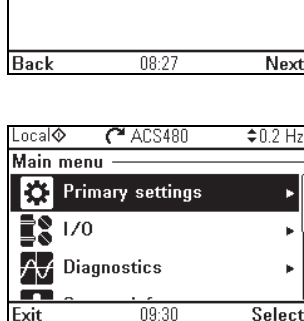

## Fieldbus communication

You can connect the drive to a serial communication link via a fieldbus adapter module or the embedded fieldbus interface. The embedded fieldbus interface is included in the I/O module, and it supports the Modbus RTU protocol. The table shows the minimum set of parameters for embedded Modbus communication. For the fieldbus adapter module settings, refer to the appropriate documentation.

**Note!** Embedded Modbus is valid with the I/O module.

To configure embedded Modbus communication:

1. Connect the fieldbus cable and the required I/O signals. Refer to *Default I/O connections* (ABB standard macro).
2. If it is necessary, set the termination switch to ON.
3. Power up the drive.
4. Select the ABB limited 2-wire macro from *Primary settings* or with parameter 96.04.
5. Configure fieldbus communication from the parameter list.

The minimum parameters that apply to embedded Modbus RTU:

Parameters	Setting
20.01 Ext1 commands	Embedded fieldbus
22.11 Ext1 speed ref 1 (vector)	EFB ref 1
28.11 Ext1 frequency ref1 (scalar)	EFB ref1
31.11 Fault reset selection	DI1
58.01 Protocol enable	Modbus RTU
58.03 Node address	1 (default)
58.04 Baud rate	19,2 kbps (default)
58.05 Parity	8 EVEN 1 (default)

6. If you need to change other parameters, you can set them manually. Refer to the *ACS480 Firmware manual* (3AXD50000047399 [EN]) and the applicable fieldbus adapter documentation.

## Warnings and faults generated by the drive

Warning	Fault	Description
A2A1	2281	Warning: Current calibration is done at the next start. Fault: Output phase current measurement fault.
A2B1	2310	Overcurrent. The output current is more than the internal limit. This can be caused by an earth fault or phase loss.
A2B3	2330	Earth leakage. A load unbalance that is typically caused by an earth fault in the motor or the motor cable.
A2B4	2340	Short circuit. There is a short circuit in the motor or the motor cable.
	3130	Input phase loss. The intermediate DC circuit voltage oscillates.
	3181	Cross connection. The input and motor cable connections are incorrect.
A3A1	3210	DC link overvoltage. There is an overvoltage in the intermediate DC circuit.
A3A2	3220	DC link undervoltage. There is an undervoltage in the intermediate DC circuit.
	3381	Output phase loss. All three phases are not connected to the motor.
A5A0	5091	Safe torque off. The Safe torque off (STO) function is on.
	6681	EFB communication loss. Break in embedded fieldbus communication.
	7510	FBA A communication. Communication lost between drive and fieldbus adapter.
A7AB	-	Extension I/O configuration failure. I/O module is not installed into drive or ABB limited macro is not selected.
AFF6	-	Identification run. The motor ID run occurs at the next start.
FA81	-	Safe torque off 1. The Safe torque off circuit 1 is broken.
FA82	-	Safe torque off 2. The Safe torque off circuit 2 is broken.

For the complete list of warnings and faults, refer to the *ACS480 Firmware manual* (3AXD50000047399 [EN]).

## Ratings

For detailed technical information, refer to the *ACS480 Hardware manual* (3AXD50000047392 [EN]).

### IEC ratings, $U_N = 400$ V

IEC type ACS480-04-...	Input rating	Input with choke	Output ratings								Frame size
			Max. current		Nominal use		Light-duty use		Heavy-duty use		
			$I_L$	$I_N$	$I_{max}$	$I_N$	$P_N$	$P_{Ld}$	$P_{Hd}$	$P_{Hd}$	
	A	A	A	A	kW	A	kW	A	kW		
02A7-4	4.2	2.6	3.2	2.6	0.75	2.5	0.75	1.8	0.55	R1	
03A4-4	5.3	3.3	4.7	3.3	1.1	3.1	1.1	2.6	0.75	R1	
04A1-4	6.4	4.0	5.9	4.0	1.5	3.8	1.5	3.3	1.1	R1	
05A7-4	9.0	5.6	7.2	5.6	2.2	5.3	2.2	4.0	1.5	R1	
07A3-4	11.5	7.2	10.1	7.2	3.0	6.8	3.0	5.6	2.2	R1	
09A5-4	15.0	9.4	13.0	9.4	4.0	8.9	4.0	7.2	3.0	R1	
12A7-4	20.2	12.6	16.9	12.6	5.5	12.0	5.5	9.4	4.0	R2	
018A-4	27.2	17.0	22.7	17.0	7.5	16.2	7.5	12.6	5.5	R3	
026A-4	40.0	25.0	30.6	25.0	11.0	23.8	11.0	17.0	7.5	R3	
033A-4	45.0	32.0	45.0	32.0	15.0	30.5	15.0	25.0	11.0	R4	
039A-4	50.0	38.0	57.6	38.0	18.5	36.0	18.5	32.0	15.0	R4	
046A-4	56.0	45.0	68.4	45.0	22.0	42.8	22.0	38.0	18.5	R4	
050A-4	60.0	50.0	81.0	50.0	22.0	48.0	22.0	45.0	22.0	R4	

### UL (NEC) ratings, $U_N = 460$ V (440-480 V) @ 60 Hz

UL (NEC) type ACS480-04-...	Input rating	Input with choke	Output ratings								Frame size
			Max. current		Nominal use		Light-duty use		Heavy-duty use		
			$I_L$	$I_N$	$I_{max}$	$I_N$	$P_N$	$P_{Ld}$	$P_{Hd}$	$P_{Hd}$	
	A	A	A	A	hp	A	hp	A	hp		
02A1-4	3.4	2.1	3.6	2.1	1.0	2.1	1.0	1.6	0.75	R1	
03A0-4	4.8	3.0	5.2	3.0	1.5	3.0	1.5	2.1	1.0	R1	
03A5-4	5.4	3.4	6.6	3.5	2.0	3.4	2.0	3.0	1.5	R1	
04A8-4	7.7	4.8	8.0	4.8	3.0	4.8	3.0	3.4	2.0	R1	
06A0-4	9.6	6.0	11.2	6.0	3.0	6.0	3.0	4.0	2.0	R1	
07A6-4	12.2	7.6	14.4	7.6	5.0	7.6	5.0	4.8	3.0	R1	
011A-4	17.6	11.0	18.8	11.0	7.5	11.0	7.5	7.6	5.0	R2	
014A-4	22.4	14.0	25.2	14.0	10.0	14.0	10.0	11.0	7.5	R3	
021A-4	33.6	21.0	34.0	21.0	15.0	21.0	15.0	14.0	10.0	R3	
027A-4	37.9	27.0	50.0	27.0	20.0	27.0	20.0	12.0	15.0	R4	
034A-4	44.7	34.0	64.0	34.0	25.0	34.0	25.0	27.0	20.0	R4	
042A-4	50.4	42.0	90.0	42.0	30.0	42.0	30.0	40.0	30.0	R4	

## Fuses

For more information on fuses, circuit breakers and manual motor protectors, refer to the *ACS480 Hardware manual* (3AXD50000047392 [EN]).

## Ambient conditions

Requirement	During operation (installed for stationary use)
Installation altitude	400 V units: 0...4000 m (0...13123 ft) above sea level (with derating above 1000 m [3281 ft]) <sup>1)</sup>
Air temperature	-10...+60 °C (14...140 °F). Above 50 °C (122 °F) derating is required. No frost allowed.
Relative humidity	5... 95% without condensation
Contamination levels (IEC 60721-3-x)	No conductive dust allowed IEC 60721-3-3: 2002 Classification of environmental conditions - Part 3-3: Classification of groups of environmental parameters and their severities - Stationary use of weather protected locations
Shock (IEC 60068-2-27, IATA 1A)	Not allowed
Free fall	Not allowed

1) Altitude derating: Up to 4000 m (13123 ft) is possible for 400 V units, if the maximum switching voltage for the integrated Relay Output 1 is 30 V at 4000 m (13123 ft) (e.g. do not connect 250 V to Relay Output 1). Up to 250 V is permitted up to 2000 m (6562 ft).

For a 3-phase 400 V drive at 4000 m (13123 ft) altitude, only the following power systems are permitted: TN-S, TN-C, TN-CS, TT (not corner earthed).

## Dimensions and weights

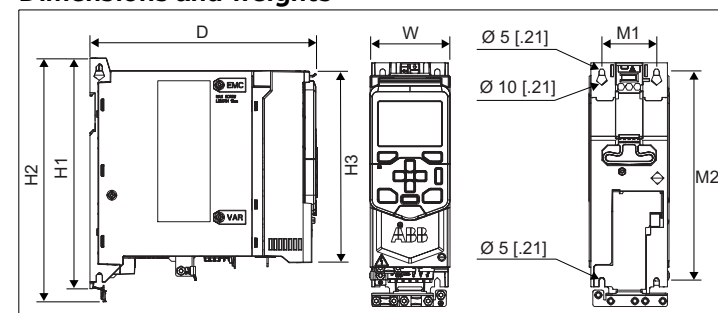

Frame size	Dimensions and weights															
	H1		H2		H3		W		D		M1		M2		Weight	
	mm	in	mm	in	mm	in	mm	in	mm	in	mm	in	mm	in	kg	lb
R1	205	8.1	223	8.8	176	6.9	73	2.8	207	8.2	50	2.0	191	7.5	1.77	3.90
R2	205	8.1	223	8.8	176	6.9	97	3.8	207	8.2	75	2.9	191	7.5	2.35	5.19
R3	205	8.1	220	8.7	176	6.9	172	6.8	207	8.2	148	5.8	191	7.5	3.52	7.76
R4	205	8.1	240	9.5	176	6.9	260	10.2	212	8.4	238	9.4	191	7.5	6.02	13.3

## Free space requirements

Frame size	Free space required							
	Above		Below		On the sides			
	mm	in	mm	in	mm	in		
R1...R4	75		2.9		75	2.9	0	0

**Note:** Side-mounted options require approximately 20 mm (0.8 in) of space on the right side of the drive.

## Certifications

The applicable certifications are shown on the product's type label.



## Declaration of conformity

**ABB**

### EU Declaration of Conformity

Machinery Directive 2006/42/EC

We  
 Manufacturer: ABB Oy  
 Address: Hiomotie 13, 00380 Helsinki, Finland.  
 Phone: +358 10 22 11

declare under our sole responsibility that the following product:  
**Frequency converter**  
**ACS480-04**  
 with regard to the safety function  
**Safe torque off**

is in conformity with all the relevant safety component requirements of EU Machinery Directive 2006/42/EC, when the listed safety function is used for safety component functionality.

The following harmonized standards have been applied:

EN 61800-5-2:2007	Adjustable speed electrical power drive systems – Part 5-2: Safety requirements - Functional
EN 62061:2005 + AC:2010 + A1:2013 + A2:2015	Safety of machinery – Functional safety of safety-related electrical, electronic and programmable electronic control systems
EN ISO 13849-1:2015	Safety of machinery – Safety-related parts of control systems. Part 1: General requirements
EN ISO 13849-2:2012	Safety of machinery – Safety-related parts of the control systems. Part 2: Validation
EN 60204-1:2006 + A1:2009 + AC:2010	Safety of machinery – Electrical equipment of machines – Part 1: General requirements

The following other standards have been applied:

IEC 61508:2010	Functional safety of electrical / electronic / programmable electronic safety-related systems
IEC 61800-5-2:2016	Adjustable speed electrical power drive systems – Part 5-2: Safety requirements - Functional

The product[s] referred in this Declaration of conformity fulfill[s] the relevant provisions of other European Union Directives which are notified in Single EU Declaration of conformity 3AXD10000594967.

Person authorized to compile the technical file:  
 Name and address: Risto Mynttinen, Hiomotie 13, 00380 Helsinki, Finland.

Helsinki, 9 Feb 2018

Manufacturer representative: Vesa Kandell, Vice President, ABB

## Related documents

Document	Code (English)
ACS480 drives hardware manual	3AXD50000047392
ACS480 standard control program firmware manual	3AXD50000047399
ACS480 quick installation and start-up guide	3AXD50000047400
FDNA-01 DeviceNet adapter module quick guide	3AXD50000158515
FENA-01/-11/-21 Ethernet adapter module user's manual	3AUA0000093568
FMBT-21 Modbus/TCP adapter module quick guide	3AXD50000158560
FPBA-01 PROFIBUS DP adapter module user's manual	3AFE68573271
FPNO-21 PROFINET adapter module quick guide	3AXD50000158577

## Online manuals applicable to this product:



List of ACS480 manuals

## Online videos:



ACS480 Installation



ACS480 Cabinet assembly



ACS480 Configuring PID controller