

TDP 0,2 + OG 9, TDPZ 0,2 + OG 9

Tachogenerator/twin tachogenerator and encoder in combination

Solid shaft with EURO flange B10 or housing foot B3 / 25...5000 pulses per revolution

Overview

- Logic level HTL or TTL
- Low response time
- Open circuit voltage 10...150 mV per rpm
- Redundant tachogenerator output (TDPZ)
- EURO flange B10 or housing foot B3
- High signal quality due to patented LongLife technology
- Recognition of sense of rotation possible via control

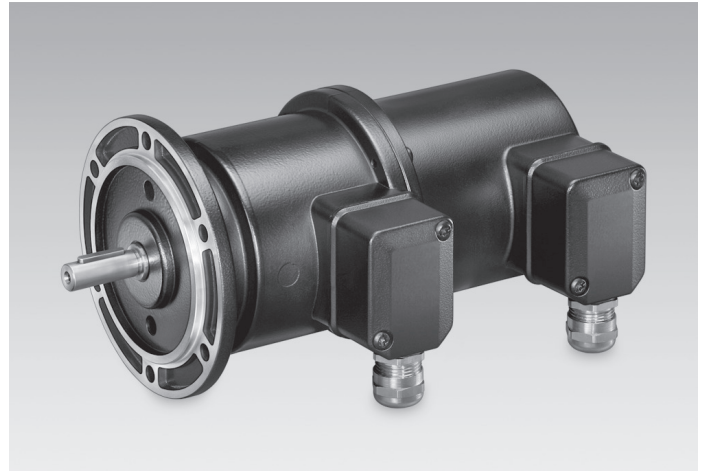

Technical data

Technical data - electrical ratings (encoder)

Voltage supply	9...30 VDC 5 VDC ±5 % 9...26 VDC
Consumption w/o load	≤100 mA
Pulses per revolution	25 ... 5000
Phase shift	90 ° ±20°
Duty cycle	40...60 %
Reference signal	Zero pulse, width 90°
Output frequency	≤120 kHz (≤300 kHz on request)
Output signals	K1, K2, K0 + inverted
Output stages	HTL-P (power linedriver) TTL/RS422
Sensing method	Optical

Technical data - electrical ratings (tachogenerator)

Reversal tolerance	≤0,1 %
Linearity tolerance	≤0,15 %
Temperature coefficient	± 0,05 %/K (open-circuit)
Isolation class	B
Calibration tolerance	±1 %
Climatic test	Humid heat, constant (IEC 60068-2-3, Ca)
Performance	TDP: 12 W (speed ≥3000 rpm) TDPZ: 2x 3 W (speed ≥3000 rpm)
Armature-circuit time-constant	<75 40 μs (TDPZ)
Open-circuit voltage	TDP: 10...150 mV per rpm TDPZ: 20...100 mV per rpm

Technical data - mechanical design

Size (flange)	ø115 mm
Shaft type	ø11 mm solid shaft
Admitted shaft load	≤60 N axial ≤80 N radial
Flange	EURO flange B10 Housing foot B3
Protection DIN EN 60529	IP 55
Operating speed	≤10000 rpm
Torque	1,5 Ncm
Rotor moment of inertia	1,4 kgcm ² (TDP) 1,5 kgcm ² (TDPZ)
Material	Housing: aluminium die-cast Shaft: stainless steel
Operating temperature	-30...+100 °C -25...+100 °C (>3072 pulses)
Resistance	IEC 60068-2-6 Vibration 10 g, 10...2000 Hz IEC 60068-2-27 Shock 100 g, 6 ms
Connection	2x terminal box
Weight approx.	3,3 kg (TDP) 3,5 kg (TDPZ)
Interference immunity	EN 61000-6-2
Emitted interference	EN 61000-6-3
Approval	CE

TDP 0,2 + OG 9, TDPZ 0,2 + OG 9

Tachogenerator/twin tachogenerator and encoder in combination

Solid shaft with EURO flange B10 or housing foot B3 / 25...5000 pulses per revolution

Terminal assignment

View A (see dimension)

Connecting terminal tachogenerator TDP
Polarity for positive rotating direction

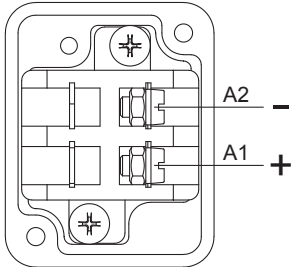

View A (see dimension)

Connecting terminal twin tachogenerator TDPZ
Polarity for positive rotating direction

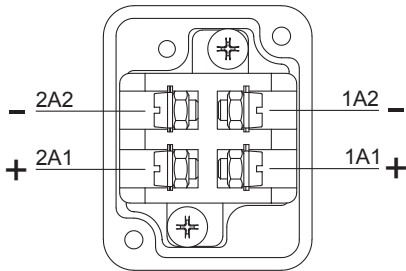

Error: 'Entity 'ampnbsp' not defined ' – near: '>ampnbsp;(see d'

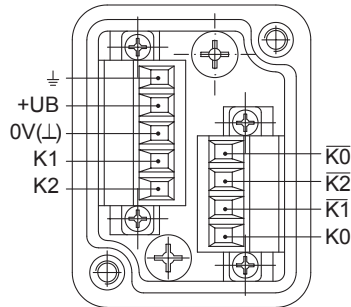

Terminal significance

Encoder incremental

+UB	Voltage supply
0V (L)	Ground
⊥	Earth ground (housing)
K1	Output signal channel 1
K1̄	Output signal channel 1 inverted
K2	Output signal channel 2 (offset by 90° to channel 1)
K2̄	Output signal channel 2 inverted
K0	Zero pulse (reference signal)
K0̄	Zero pulse inverted

Output signals incremental

HTL/TTL

At positive rotating direction (see dimension)

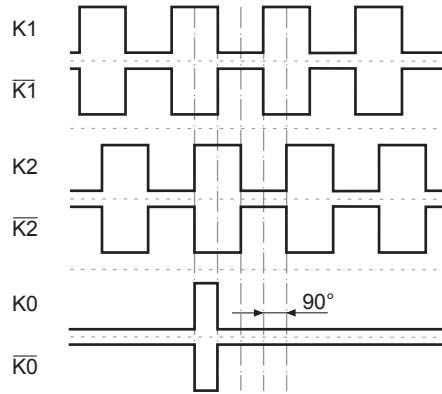

TDP 0,2 + OG 9, TDPZ 0,2 + OG 9

Tachogenerator/twin tachogenerator and encoder in combination

Solid shaft with EURO flange B10 or housing foot B3 / 25...5000 pulses per revolution

Dimensions

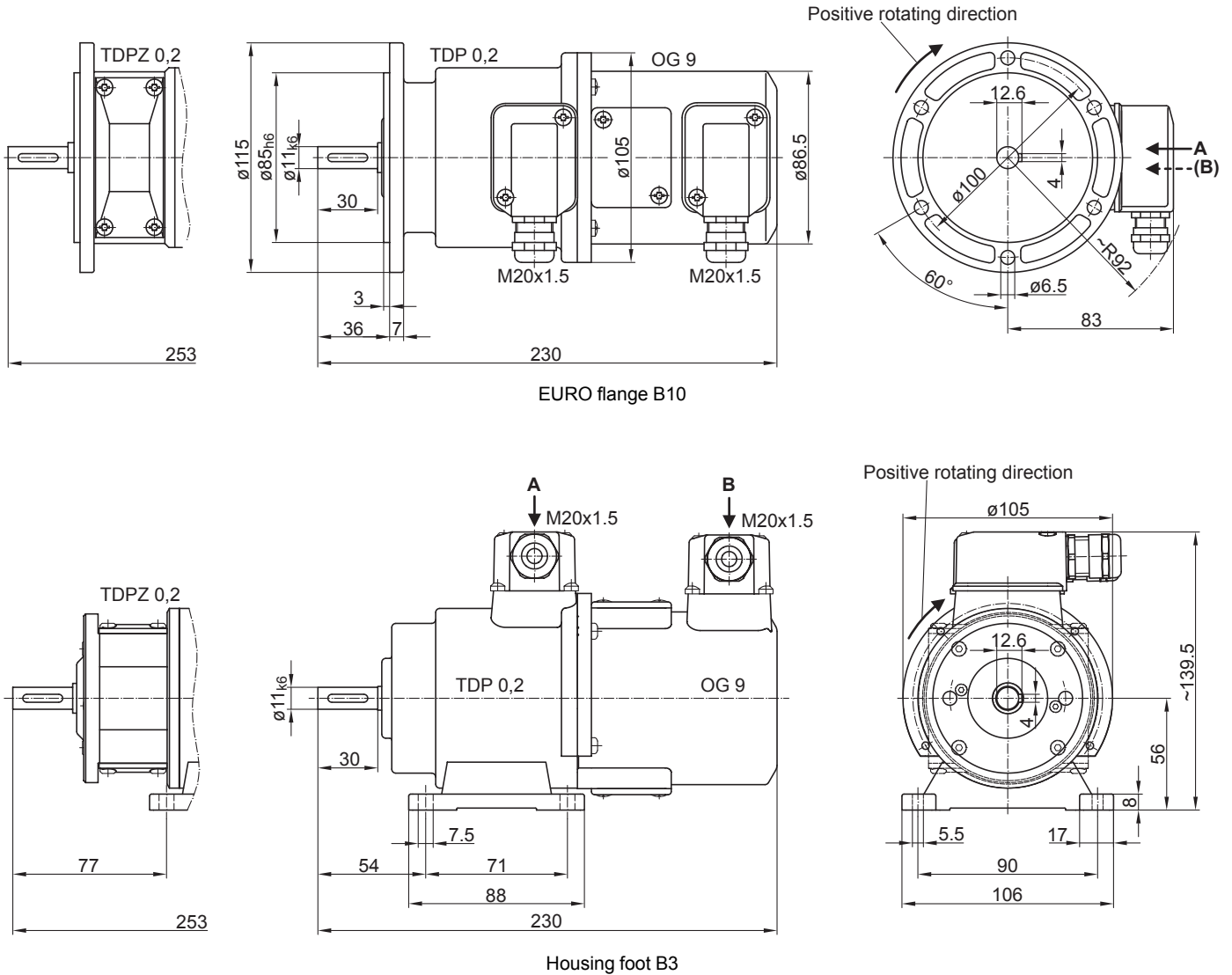

TDP 0,2 + OG 9, TDPZ 0,2 + OG 9

Tachogenerator/twin tachogenerator and encoder in combination

Solid shaft with EURO flange B10 or housing foot B3 / 25...5000 pulses per revolution

Ordering reference

	TDP	#	#####	#####	55	+ OG 9	DN	####	###
Product	TDP								
Tachogenerator + encoder									
Design									
Tachogenerator									
Twin tachogenerator		Z							
Open-circuit voltage									
10 mV per rpm (not available for TDPZ)			0,2LT-6						
20 mV per rpm			0,2LT-7						
30 mV per rpm			0,2LT-10						
40 mV per rpm			0,2LT-5						
60 mV per rpm			0,2LT-4						
100 mV per rpm			0,2LT-3						
150 mV per rpm (not available for TDPZ)			0,2LT-1						
Mounting type									
EURO flange B10				B10					
Housing foot B3				B3					
Protection									
IP 55					55				
Version encoder									
Incremental encoder OG 9						+ OG 9			
Output signals									
K1, K2, K0							DN		
Pulse number⁽¹⁾									
25									25
120									120
128									128
180									180
256									256
360									360
500									500
512									512
720									720
1000									1000
1024									1024
1250									1250
2048									2048
2500									2500
3072									3072
4096									4096
5000									5000
Voltage supply / output stage									
9...30 VDC / output stage HTL with inverted signals									I
5 VDC / output stage TTL with inverted signals									TTL
9...30 VDC / output stage TTL with inverted signals ⁽²⁾									R

(1) Other pulse numbers on request.

(2) <95 pulses: 9...26 VDC / ≥95 pulses: 9...30 VDC

TDP 0,2 + OG 9, TDPZ 0,2 + OG 9

Tachogenerator/twin tachogenerator and encoder in combination

Solid shaft with EURO flange B10 or housing foot B3 / 25...5000 pulses per revolution

Data according to type

Type	Open-circuit voltage U_0 [mV/rpm]	Minimum load required depending on speed range [rpm]			Maximum operating speed n_{max} [rpm]	Armature resistance R_A (20°C) [Ω]	Armature inductance L_A [mH]
		0-3000 R_L [kΩ]	0-6000 R_L [kΩ]	0- n_{max} R_L [kΩ]			
TDP0,2 LT-6	10	≥0.1	≥0.3	≥0.9	10000	3	6
TDP0,2 LT-7	20	≥0.3	≥1.2	≥3.3	10000	11	23
TDP0,2 LT-10	30	≥0.7	≥2.7	≥7.5	10000	26	50
TDP0,2 LT-5	40	≥1.2	≥5	≥13.5	10000	47	90
TDP0,2 LT-4	60	≥2.7	≥11	≥30	10000	99	200
TDP0,2 LT-3	100	≥7.5	≥30	≥30	6000	271	550
TDP0,2 LT-1	150	≥16	---	≥30	4000	630	1260

Twin tachogenerator with redundant output
(The data refer to each of the two tachogenerator outputs)

TDPZ0,2 LT-7	20	≥1.2	≥4.8	≥14	10000	19	45
TDPZ0,2 LT-10	30	≥2.7	≥11	≥30	10000	42	103
TDPZ0,2 LT-5	40	≥4.8	≥20	≥54	10000	70	170
TDPZ0,2 LT-4	60	≥11	≥44	≥120	10000	160	390
TDPZ0,2 LT-3	100	≥30	≥120	---	6000	445	1080

Superimposed ripple (for $\tau_{RC} = 0.7$ ms): ≤0.5% (peak-peak) ≤0.2% (rms)

Replacement switching diagram

Tachogenerator

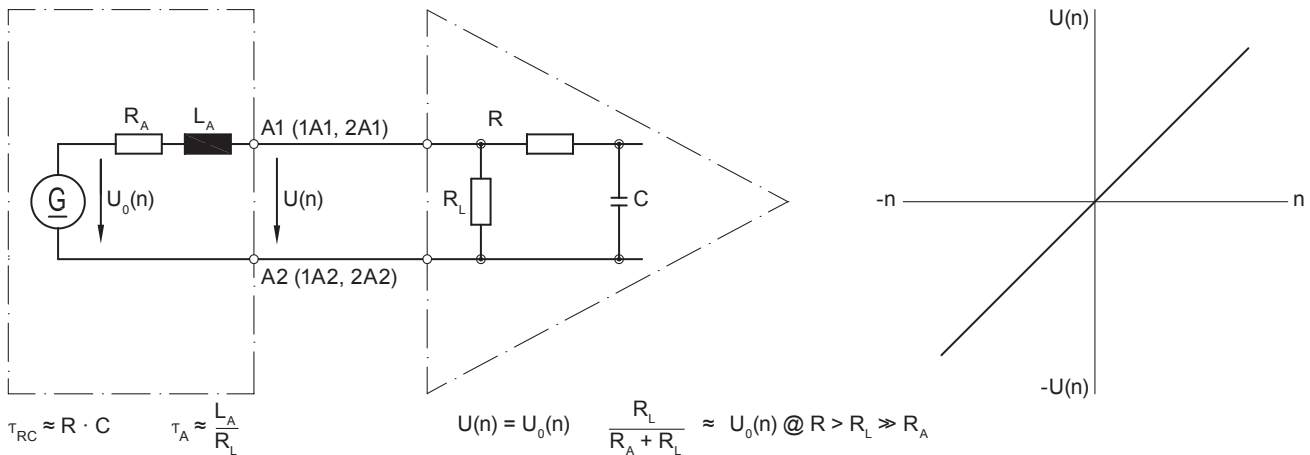

Polarity for positive rotating direction (see dimension) / A1 (1A1, 2A1): + (VDE) / A2 (1A2, 2A2): - (VDE)

Accessories

Mounting accessories

- Spring disk coupling K 35 (shaft ø6...12 mm)
- Spring disk coupling K 50 (shaft ø11...16 mm)
- Spring disk coupling K 60 (shaft ø11...22 mm)

Connectors and cables

- Sensor cable for encoders HEK 8

Diagnostic accessories

- 11075858 Analyzer for encoders HENQ 1100
- 11075880 Analyzer for encoders HENQ 1100 with a power pack

Accessories

Spare parts

- Carbon brushes (on request)