

Synchronous Servomotors MSK

Project planning manual
R911296289

Edition 12



Title	Synchronous Servomotors MSK
Type of Documentation	Project planning manual
Document Typecode	DOK-MOTOR*-MSK*****-PR12-EN-P
Internal File Reference	RS-d170bab768c990d90a6846a500789bc3-5-en-US-2
Purpose of Documentation	<p>This documentation</p> <ul style="list-style-type: none">• explains the features of the product, possibilities for use, operating conditions and operational limits of MSK motors.• contains technical data regarding available MSK motors.• provides information regarding product selection, handling and operation.
Record of revisions	<p>Edition 12, 2018-06</p> <p>See "Editions of this documentation" on page 7</p>
Copyright	<p>© Bosch Rexroth AG 2018</p> <p>All rights reserved, also regarding any disposal, exploitation, reproduction, editing, distribution, as well as in the event of applications for industrial property rights.</p>
Liability	<p>The specified data is intended for product description purposes only and shall not be deemed to be a guaranteed characteristic unless expressly stipulated in the contract. All rights are reserved with respect to the content of this documentation and the availability of the product.</p>

Table of Contents

	Page
1 About this documentation.....	7
1.1 Introduction.....	8
2 Important instructions on use.....	11
2.1 Intended use	11
2.1.1 Introduction.....	11
2.1.2 Areas of use and application.....	11
2.2 Inappropriate use.....	12
3 Safety notes for electric drives and controls.....	13
3.1 Term definition.....	13
3.2 General information.....	14
3.2.1 Using the Safety instructions and passing them on to others.....	14
3.2.2 Requirements for safe use.....	14
3.2.3 Hazards by improper use.....	15
3.3 Danger-related notes.....	16
3.3.1 Protection against Touch of Electric Parts and Housings.....	16
3.3.2 Protective extra-low voltage as protection against electric shock	17
3.3.3 Protection against dangerous movements.....	17
3.3.4 Protection against electromagnetic and magnetic fields during operation and mounting.....	19
3.3.5 Protection against contact with hot parts.....	19
3.3.6 Protection during handling and mounting.....	19
3.3.7 Battery safety.....	20
3.3.8 Protection against pressurized systems.....	20
3.4 Explanation of signal words and the Safety alert symbol.....	21
4 Technical data.....	23
4.1 Description of the specified parameters.....	23
4.2 IndraSize.....	26
4.3 Technical data encoder MSK motors.....	27
4.4 Technical data holding brakes.....	28
4.5 MSK030B Technical data.....	30
4.6 MSK030C Technical data.....	31
4.7 MSK040B Technical data.....	32
4.8 MSK040C Technical data.....	34
4.9 MSK043C Technical data.....	36
4.10 MSK050B Technical data.....	38
4.11 MSK050C Technical data.....	40
4.12 MSK060B Technical data.....	42
4.13 MSK060C Technical data.....	44
4.14 MSK061B Technical data.....	46
4.15 MSK061C Technical data.....	47
4.16 MSK070C Technical data.....	50

Table of Contents

	Page
4.17	MSK070D Technical data..... 53
4.18	MSK070E Technical data..... 56
4.19	MSK071C Technical data..... 59
4.20	MSK071D Technical data..... 62
4.21	MSK071E Technical data..... 65
4.22	MSK075C Technical data..... 68
4.23	MSK075D Technical data..... 71
4.24	MSK075E Technical data..... 74
4.25	MSK076C Technical data..... 77
4.26	MSK100A Technical data..... 79
4.27	MSK100B Technical data..... 82
4.28	MSK100C Technical data..... 85
4.29	MSK100D Technical data..... 88
4.30	MSK101C Technical data..... 91
4.31	MSK101D Technical data..... 94
4.32	MSK101E Technical data..... 97
4.33	MSK103A Technical data..... 100
4.34	MSK103B Technical data..... 101
4.35	MSK103D Technical data..... 102
4.36	MSK131B Technical data..... 103
4.37	MSK131D Technical data..... 105
4.38	MSK133B Technical data..... 107
4.39	MSK133C Technical data..... 110
4.40	MSK133D Technical data..... 113
4.41	MSK133E Technical data..... 117
4.42	MSK133 Technical data fan..... 120
5	Specifications..... 121
5.1	Technical design 121
5.2	MSK030 Specifications..... 122
5.3	MSK040 Specifications..... 123
5.4	MSK043 Specifications..... 124
5.5	MSK050 Specifications..... 125
5.6	MSK060 Specifications..... 126
5.7	MSK060 Specifications fan unit axial..... 127
5.8	MSK060 Specifications fan unit radial..... 128
5.9	MSK061 Specifications..... 129
5.10	MSK061 Specifications fan unit axial..... 130
5.11	MSK061 Specifications fan unit radial..... 131
5.12	MSK070 Specifications..... 132
5.13	MSK070 Specifications fan unit axial..... 133
5.14	MSK070 Specifications fan unit radial..... 134
5.15	MSK071 Specifications..... 135
5.16	MSK071 Specifications liquid cooling..... 136
5.17	MSK071 Specifications fan unit axial..... 137
5.18	MSK071 Specifications fan unit radial..... 138

Table of Contents

	Page
5.19 MSK075 Specifications.....	139
5.20 MSK075 Specifications liquid cooling.....	140
5.21 MSK075 Specifications axial fan unit.....	141
5.22 MSK075 Specifications fan unit radial.....	142
5.23 MSK076 Specifications.....	143
5.24 MSK076 Specifications fan unit axial.....	144
5.25 MSK076 Specifications fan unit radial.....	145
5.26 MSK100 Specifications.....	146
5.27 MSK100 Specifications fan unit axial.....	147
5.28 MSK100 Specifications radial fan unit.....	148
5.29 MSK101 Specifications.....	149
5.30 MSK101 Specifications liquid cooling.....	150
5.31 MSK101 Specifications fan unit axial.....	151
5.32 MSK101 Specifications radial fan unit.....	152
5.33 MSK103 Specifications.....	153
5.34 MSK131 Specifications.....	154
5.35 MSK131 Specifications fan unit axial.....	155
5.36 MSK133 Specifications.....	156
5.37 MSK133 Specifications liquid cooling.....	157
6 Type code.....	159
6.1 MSK type code - structure and description.....	159
6.2 MSK030 Type code.....	161
6.3 MSK040 Type code.....	162
6.4 MSK043 Type code.....	163
6.5 MSK050 Type code.....	164
6.6 MSK060 Type code.....	165
6.7 MSK061 Type code.....	166
6.8 MSK070 Type code.....	167
6.9 MSK071 Type code.....	168
6.10 MSK075 Type code.....	169
6.11 MSK076 Type code.....	170
6.12 MSK100 Type code.....	171
6.13 MSK101 Type code.....	173
6.14 MSK103 Type code	175
6.15 MSK131 Type code.....	176
6.16 MSK133 Type code.....	177
7 Accessories.....	179
7.1 Transmission.....	179
7.2 Fan units for MSK motors.....	180
7.2.1 Fan units area of application.....	180
7.2.2 Fan unit type key.....	181
7.2.3 Fan unit technical data	182
7.2.4 Fan unit selection table.....	184

Table of Contents

	Page
7.2.5	Fan units electrical connection..... 186
7.2.6	Fan units ordering..... 188
7.2.7	Fan units assembly..... 188
7.3	Sealing air connection..... 188
7.3.1	Description..... 188
7.3.2	Technical data..... 188
7.3.3	Ordering data and assignment..... 189
7.3.4	Assembly instructions..... 189
8	Connection technique..... 191
8.1	Overview of the electrical connection technique..... 191
8.2	Plug-in power connector..... 192
8.3	Encoder plug connector..... 195
8.4	Plug connector, rotatable..... 196
8.5	RLK1200 Terminal box..... 198
8.6	Terminal box RLK1300..... 199
8.7	Connection cables..... 199
8.8	Liquid cooling connection 201
9	Operating conditions and application notes..... 203
9.1	Environmental conditions 203
9.1.1	Installation altitude and ambient temperature..... 203
9.1.2	Humidity / temperature 204
9.1.3	Vibration..... 205
9.1.4	Shock..... 206
9.2	Degree of protection..... 207
9.3	Design and installation positions..... 208
9.4	Compatibility with foreign materials..... 210
9.5	Motor paint..... 211
9.6	Output shaft..... 212
9.6.1	Plain shaft..... 212
9.6.2	Output shaft with keyway..... 212
9.6.3	Output shaft with shaft sealing ring..... 212
9.7	Bearing and shaft load..... 214
9.7.1	Radial load, axial load..... 214
9.8	Bearing lifetime..... 219
9.9	Attachment of drive elements..... 220
9.10	Holding brakes..... 221
9.10.1	Holding brake electrically releasing..... 221
9.10.2	Holding brakes safety instructions..... 221
9.10.3	Design of holding brakes..... 222
9.10.4	Holding brake - commissioning and maintenance instructions..... 223
9.11	Acceptances and approvals..... 224
9.11.1	CE..... 224
9.11.2	cURus..... 224

Table of Contents

	Page
9.11.3 EAC	224
9.11.4 RoHS	224
9.11.5 China RoHS 2.....	225
9.12 Motor cooling.....	226
9.12.1 Natural convection.....	226
9.12.2 Fan units.....	226
9.12.3 Liquid cooling.....	227
9.13 Motor temperature monitoring.....	234
9.13.1 General information.....	234
9.13.2 Temperature sensor.....	234
9.14 Operation on external controllers.....	235
10 Transport and storage.....	237
10.1 Transport Instructions.....	237
10.2 Storage instructions.....	238
10.2.1 Storage conditions.....	238
10.2.2 Storage times.....	239
11 Delivery condition, identification, handling.....	241
11.1 Delivery condition.....	241
11.1.1 General information.....	241
11.1.2 Factory inspection.....	241
11.1.3 Customer inspection.....	241
11.2 Identification	242
11.2.1 Scope of delivery.....	242
11.2.2 Type plate.....	242
11.3 Handling.....	244
12 Installation.....	247
12.1 Safety.....	247
12.2 Specialist personnel.....	248
12.3 Mechanical attachment.....	249
12.3.1 Flange attachment.....	249
12.3.2 Foot attachment.....	249
12.3.3 Preparation.....	250
12.3.4 Motor mounting.....	250
12.4 Electrical connection - connect motor.....	252
12.4.1 General information.....	252
12.4.2 Connecting the plug-in connector.....	253
12.5 MSK133 with terminal box type RLK1200, RLK1300.....	254
13 Commissioning, operation and maintenance	259
13.1 Commissioning.....	259
13.2 Operation.....	260
13.3 Shutdown.....	260

Table of Contents

	Page
13.4 Maintenance.....	261
13.4.1 General information.....	261
13.4.2 Cleaning.....	261
13.4.3 Bearings.....	262
13.4.4 Connecting cables.....	262
13.5 Information in case of malfunctions	263
13.6 Disassembly.....	265
14 Environmental protection and disposal	267
14.1 Environmental protection.....	267
14.2 Disposal.....	267
15 Appendix.....	269
15.1 EU Declaration of conformity.....	269
16 Service and support.....	273
Index.....	275

1 About this documentation

Editions of this documentation

Edition	State	Note
01	2004-06	First edition
02	2004-10	Revision, supplements
04	2005-06	Revision, supplements
06	2006-12	Revision, supplements
07	2008-06	Revision, supplements
08	2008-09	Revision, supplements
09	2010-12	Revision, supplements
10	2013-10	Revision, supplements
11		Not published
12	2018-06	MSK050: correction of technical data holding brakes M ₄ (6 Nm) MSK133: revision of characteristic curves, specifications New: Fan unit LEM-RB-192T-x1-NNNA, specifications MSK100, MSK101 Editorial revision

Tab. 1-1: Change history

About this documentation

1.1 Introduction

MSK synchronous servo motors for all requirements

The MSK motor series is characterized in particular by its wide performance spectrum and fine size gradation. The high torque density of these synchronous servo motors enables a particularly compact design with a maximum torque of up to 631 Nm.

Depending on the required accuracy, you can choose between encoder systems with low, medium or high resolution. All encoder variants are available in single-turn or multi-turn versions.

With numerous other options, the MSK motors can be upgraded and precisely tailored to the desired requirements. The MSK series is therefore also suitable for applications that go beyond the classic areas of application for servo motors.

The wide performance spectrum of the MSK motor series is supplemented by a large number of functional options.

In addition to the various encoder systems, numerous other options such as keyway, holding brake and increased concentricity accuracy can be selected. Fan units for axial and radial mounting are available for applications with increased continuous performance.

Just like the MSK motors themselves, the fan motors are also designed with IP65 protection and equipped with an integrated temperature sensor. This not only increases the reliability of the motors. The certified intrinsic safety of the fans ("Thermally Protected F" according to UL) also eliminates the need for external motor protection switches. The motors cover the highest performance requirements with the aid of liquid cooling, which is available for selected sizes.

Document structure

This documentation focuses on the following topics:

Chapter	Title	Content
1	About this documentation	General information
2	Important instructions for use	Safety
3	Safety notes for electric drives and controls	
4	Technical data	Product description (for planners and designers)
5	Specifications	
6	Type code	
7	Accessories	
8	Connection technique	
9	Operating conditions and application notes	
10	Transport and storage	Practical application (for operating and maintenance personnel)
11	Delivery condition, identification, handling	
12	Installation	
13	Commissioning, operation and maintenance	General information
14	Environmental protection and disposal	
15	Appendix	
16	Service & support	
	Index	

Tab. 1-2: Document structure

About this documentation

- Further documentation** For the project planning of drive systems with motors of the MSK series, you will require further documentation, depending on the devices used. Rexroth provides the entire product documentation in the Bosch Rexroth media directory in PDF format.
<http://www.boschrexroth.com/various/utilities/mediadirectory/index.jsp>
- Standards** This documentation refers to German, European and international technical standards. Standard typefaces and standard sheets are protected by copyright and may not be passed on by Rexroth. If need be, please contact the authorized sales outlets or, in Germany, directly:
BEUTH Verlag GmbH
Burggrafenstrasse 6
10787 Berlin
Phone +49-(0)30-26 01-22 60, Fax +49-(0)30-26 01-12 60
Internet: <http://www.din.de/beuth>
Email: postmaster@beuth.de
- External systems** Documentation for external systems connected with Rexroth components is not part of the scope of delivery and must be requested directly from these manufacturers.
- Feedback** For us, your experience is an important part of the improvement process for product and documentation.
Please send your comments to dokusupport@boschrexroth.de.

2 Important instructions on use

2.1 Intended use

2.1.1 Introduction

Rexroth products are developed and manufactured according to the state of the art. Before they are delivered, they are inspected to ensure that they operate safely.

WARNING

Improper product handling may result in personal injury and property damage!

The products must only be used as intended. If they are not used as intended, situations may arise that result in personal injuries or damage to property.



Rexroth, as the manufacturer, does not provide any warranty, assume any liability, or pay any damages for damage caused by products not being used as intended. Any risks resulting from the products not being used as intended are the sole responsibility of the user.

Before using Rexroth products, the following condition precedent must be fulfilled so as to ensure that they are used as intended:

- Everyone who in any way whatsoever handles one of our products must read and understand the corresponding notes regarding safety and regarding the intended use.
- The motors must be left in their original state. It is not allowed to do any constructional modifications. Software products may not be decompiled; their source codes may not be modified.
- Damaged or improperly working products may not be installed or put into operation.
- It must be ensured that the products are installed according to the regulations specified in the documentation.

2.1.2 Areas of use and application

Rexroth IndraDyn A series asynchronous motors ApplicationsMSK are designed to be used as rotary main and servo drive motors. The following are typical fields of application:

- Machine tools
- Printing and paper-processing machines,
- Packaging and Food-processing machines,
- Metal-forming machines
- Robotics

Device types with different driving powers and different interfaces are available for an application-specific use of the motors.

Controlling and monitoring of the motors may require connection of additional sensors and actuators.

Important instructions on use



MSK The motors must only be used with the accessories specified in this documentation. Components that are not explicitly mentioned may neither be attached nor connected. The same is applicable for cables and lines.

Operation is only allowed in the explicitly mentioned configurations and combinations of the component and with the software and firmware specified in the corresponding functional description.

Any connected drive controller must be programmed before startup in order to ensure that the motor executes the functions specifically to the particular application.

MSK The motors may only be operated under the assembly, mounting and installation conditions, in the normal position, and under the environmental conditions (temperature, degree of protection, humidity, EMC etc.) specified in this documentation.

2.2 Inappropriate use

Any use MSK of motors outside of the fields of application mentioned above or under operating conditions and technical data other than those specified in this documentation is considered as "non-intended use".

MSK motors may not be used if . . .

- they are subject to operating conditions which do not comply with the ambient conditions described above; for example, they may not be operated under water, under extreme temperature fluctuations or extreme maximum temperatures;
- the intended application is not explicitly released by Bosch Rexroth. Please be absolutely sure to comply with the instructions given in the general safety instructions!

3 Safety notes for electric drives and controls

3.1 Term definition

System	An installation consists of several devices or systems interconnected for a defined purpose and on a defined site which, however, are not intended to be placed on the market as a single functional unit.
Electrical drive system	An electric drive system comprises all components from mains supply to motor shaft; this includes, for example, electric motor(s), motor encoder(s), supply units and drive controllers, as well as auxiliary and additional components, such as mains filter, mains choke and the corresponding lines and cables.
User	A user is a person installing, commissioning or using a product which has been placed on the market.
User documentation	Application documentation comprises the entire documentation used to inform the user of the product about the use and safety-relevant features for configuring, integrating, installing, mounting, commissioning, operating, maintaining, repairing and decommissioning the product. The following terms are also used for this kind of documentation: Operating Instructions, Commissioning Manual, Instruction Manual, Project Planning Manual, Application Description, etc.
Electrical equipment	Electrical equipment encompasses all devices used to generate, convert, transmit, distribute or apply electrical energy, such as electric motors, transformers, switching devices, cables, lines, power-consuming devices, circuit board assemblies, plug-in units, control cabinets, etc.
Device	A device is a finished product with a defined function, intended for users and placed on the market as an individual piece of merchandise.
Manufacturer	The manufacturer is an individual or legal entity bearing responsibility for the design and manufacture of a product which is placed on the market in the individual's or legal entity's name. The manufacturer can use finished products, finished parts or finished elements, or contract out work to subcontractors. However, the manufacturer must always have overall control and possess the required authority to take responsibility for the product.
Components	A component is a combination of elements with a specified function, which are part of a piece of equipment, device or system. Components of the electric drive and control system are, for example, supply units, drive controllers, mains choke, mains filter, motors, cables, etc.
Machine	A machine is the entirety of interconnected parts or units at least one of which is movable. Thus, a machine consists of the appropriate machine drive elements, as well as control and power circuits, which have been assembled for a specific application. A machine is, for example, intended for processing, treatment, movement or packaging of a material. The term "machine" also covers a combination of machines which are arranged and controlled in such a way that they function as a unified whole.
Product	Examples of a product: Device, component, part, system, software, firmware, among other things.
Project planning manual	A Project Planning Manual is part of the application documentation used to support the sizing and planning of systems, machines or installations.
Qualified personnel	In terms of this application documentation, qualified persons are those persons who are familiar with the installation, mounting, commissioning and operation of the components of the electric drive and control system, as well as with the hazards this implies, and who possess the qualifications their work

Safety notes for electric drives and controls

requires. To comply with these qualifications, it is necessary, among other things,

- 1) to be trained, instructed or authorized to switch electric circuits and devices safely on and off, to ground them and to mark them
- 2) to be trained or instructed to maintain and use adequate safety equipment
- 3) to attend a course of instruction in first aid

Control system A control system comprises several interconnected control components placed on the market as a single functional unit.

3.2 General information

3.2.1 Using the Safety instructions and passing them on to others

Do not attempt to install and operate the components of the electric drive and control system without first reading all documentation provided with the product. Read and understand these safety instructions and all user documentation prior to working with these components. If you do not have the user documentation for the components, contact your responsible Rexroth sales partner. Ask for these documents to be sent immediately to the person or persons responsible for the safe operation of the components.

If the component is resold, rented and/or passed on to others in any other form, these safety instructions must be delivered with the component in the official language of the user's country.

Improper use of these components, failure to follow the safety instructions in this document or tampering with the product, including disabling of safety devices, could result in property damage, injury, electric shock or even death.

3.2.2 Requirements for safe use

Read the following instructions before initial commissioning of the components of the electric drive and control system in order to eliminate the risk of injury and/or property damage. You must follow these safety instructions.

- Rexroth is not liable for damages resulting from failure to observe the safety instructions.
- Read the operating, maintenance and safety instructions in your language before commissioning. If you find that you cannot completely understand the application documentation in the available language, please ask your supplier to clarify.
- Proper and correct transport, storage, mounting and installation, as well as care in operation and maintenance, are prerequisites for optimal and safe operation of the component.
- Only qualified persons may work with components of the electric drive and control system or within its proximity.
- Only use accessories and spare parts approved by Rexroth.
- Follow the safety regulations and requirements of the country in which the components of the electric drive and control system are operated.
- Only use the components of the electric drive and control system in the manner that is defined as appropriate. See chapter "Appropriate Use".
- The ambient and operating conditions given in the available application documentation must be observed.
- Applications for functional safety are only allowed if clearly and explicitly specified in the application documentation "Integrated Safety Technolo-

Safety notes for electric drives and controls

gy". If this is not the case, they are excluded. Functional safety is a safety concept in which measures of risk reduction for personal safety depend on electrical, electronic or programmable control systems.

- The information given in the application documentation with regard to the use of the delivered components contains only examples of applications and suggestions.

The machine and installation manufacturers must

- make sure that the delivered components are suited for their individual application and check the information given in this application documentation with regard to the use of the components,
- make sure that their individual application complies with the applicable safety regulations and standards and carry out the required measures, modifications and complements.
- Commissioning of the delivered components is only allowed once it is sure that the machine or installation in which the components are installed complies with the national regulations, safety specifications and standards of the application.
- Operation is only allowed if the national EMC regulations for the application are met.
- The instructions for installation in accordance with EMC requirements can be found in the section on EMC in the respective application documentation.

The machine or installation manufacturer is responsible for compliance with the limit values as prescribed in the national regulations.

- The technical data, connection and installation conditions of the components are specified in the respective application documentations and must be followed at all times.

National regulations which the user has to comply with

- European countries: In accordance with European EN standards
- United States of America (USA):
 - National Electrical Code (NEC)
 - National Electrical Manufacturers Association (NEMA), as well as local engineering regulations
 - Regulations of the National Fire Protection Association (NFPA)
- Canada: Canadian Standards Association (CSA)
- Other countries:
 - International Organization for Standardization (ISO)
 - International Electrotechnical Commission (IEC)

3.2.3 Hazards by improper use

- High electrical voltage and high working current! Danger to life or serious injury by electric shock!
- High electrical voltage by incorrect connection! Danger to life or injury by electric shock!
- Dangerous movements! Danger to life, serious injury or property damage by unintended motor movements!
- Health hazard for persons with heart pacemakers, metal implants and hearing aids in proximity to electric drive systems!

Safety notes for electric drives and controls

- Risk of burns by hot housing surfaces!
- Risk of injury by improper handling! Injury by crushing, shearing, cutting, hitting!
- Risk of injury by improper handling of batteries!
- Risk of injury by improper handling of pressurized lines!

3.3 Danger-related notes

3.3.1 Protection against Touch of Electric Parts and Housings



This section concerns components of electric drive and control systems with a voltage **over 50 volt**.

In the case of touching parts with a voltage higher than 50 volt, this can be dangerous for personnell and can lead to electric shock. During operation of components of electric drive and control systems, certain parts of these components are inevitably under dangerous voltage.

High electrical voltage! Danger of life, risk of injury due to electric shock or heavy bodily harm.

- Operation, maintenance and/or repair of components of electric drive and control systems may only be done by qualified personnel.
- Observe the general construction and safety instructions about work on high voltage systems.
- Before switching on, establish the fixed connection of the protective conductor to all electric components according to the interconnection diagram.
- Operation, even for short-term measuring and testing purposes, is only permitted with the protective conductor securely connected to the component points provided.
- Disconnect electric components from the mains or from the power supply, before you have contact with electric parts with a voltage higher than 50 V. Secure the electric components against restarting.
- Observe for electrical components:
Please, always wait **30 minutes**, after switch-off, so live capacitors discharge before they have access to electric components. To exclude any danger due to any contact, measure electric voltage of live parts before working.
- Before switch-on install the provided covers and protective devices for the touch guard.
- Do not touch any electric junctions of live components.
- Do not disconnect or connect connectors under voltage.

High housing voltage and high discharge current! Danger! Risk of injury due to electric shock!

- Before switch-on and start-up, ground or connect the components of the drive and control system with the protective conductors on the ground-points.

Safety notes for electric drives and controls

- Connect the protective conductors of the electric drive and control systems always fix and continuously with the external supply network.
- Do a protective conductor connection with a minimum cross section according to the following table.

Cross-sectional area A of the live wires	Minimum cross-sectional area A_{PE} of the protective conductor
$A \leq 16 \text{ mm}^2$	A
$25 \text{ mm}^2 < A \leq 50 \text{ mm}^2$	25 mm ²
$50 \text{ mm}^2 < A$	A / 2

Tab. 3-1: Minimum cross-section of protective conductor connection for motors

3.3.2 Protective extra-low voltage as protection against electric shock

Protective extra-low voltage is used to allow connecting devices with basic insulation to extra-low voltage circuits.

On components of an electric drive and control system provided by Rexroth, all connections and terminals with voltages up to 50 volts are PELV ("Protective Extra-Low Voltage") systems. It is allowed to connect devices equipped with basic insulation (such as programming devices, PCs, notebooks, display units) to these connections.

Danger to life, risk of injury by electric shock! High electrical voltage by incorrect connection!

If extra-low voltage circuits of devices containing voltages and circuits of more than 50 volts (e.g., the mains connection) are connected to Rexroth products, the connected extra-low voltage circuits must comply with the requirements for PELV ("Protective Extra-Low Voltage").

3.3.3 Protection against dangerous movements

Dangerous movements can be caused by faulty control of connected motors. Some common examples are:

- Improper or wrong wiring or cable connection
- Operator errors
- Wrong input of parameters before commissioning
- Malfunction of sensors and encoders
- Defective components
- Software or firmware errors

These errors can occur immediately after equipment is switched on or even after an unspecified time of trouble-free operation.

The monitoring functions in the components of the electric drive and control system will normally be sufficient to avoid malfunction in the connected drives. Regarding personal safety, especially the danger of injury and/or property damage, this alone cannot be relied upon to ensure complete safety. Until the integrated monitoring functions become effective, it must be assumed in any case that faulty drive movements will occur. The extent of faulty drive movements depends upon the type of control and the state of operation.

Safety notes for electric drives and controls

Dangerous movements! Danger to life, risk of injury, serious injury or property damage!

A **risk assessment** must be prepared for the installation or machine, with its specific conditions, in which the components of the electric drive and control system are installed.

As a result of the risk assessment, the user must provide for monitoring functions and higher-level measures on the installation side for personal safety. The safety regulations applicable to the installation or machine must be taken into consideration. Unintended machine movements or other malfunctions are possible if safety devices are disabled, bypassed or not activated.

To avoid accidents, injury and/or property damage:

- Keep free and clear of the machine's range of motion and moving machine parts. Prevent personnel from accidentally entering the machine's range of motion by using, for example:
 - Safety fences
 - Safety guards
 - Protective coverings
 - Light barriers
- Make sure the safety fences and protective coverings are strong enough to resist maximum possible kinetic energy.
- Mount emergency stopping switches in the immediate reach of the operator. Before commissioning, verify that the emergency stopping equipment works. Do not operate the machine if the emergency stopping switch is not working.
- Prevent unintended start-up. Isolate the drive power connection by means of OFF switches/OFF buttons or use a safe starting lockout.
- Make sure that the drives are brought to safe standstill before accessing or entering the danger zone.
- Additionally secure vertical axes against falling or dropping after switching off the motor power by, for example,
 - mechanically securing the vertical axes,
 - adding an external braking/arrestor/clamping mechanism or
 - ensuring sufficient counterbalancing of the vertical axes.
- The standard equipment **motor holding brake** or an external holding brake controlled by the drive controller is **not sufficient to guarantee personal safety!**
- Disconnect electrical power to the components of the electric drive and control system using the master switch and secure them from reconnection ("lock out") for:
 - Maintenance and repair work
 - Cleaning of equipment
 - Long periods of discontinued equipment use
- Prevent the operation of high-frequency, remote control and radio equipment near components of the electric drive and control system and their supply leads. If the use of these devices cannot be avoided, check the machine or installation, at initial commissioning of the electric drive and control system, for possible malfunctions when operating such high-frequency, remote control and radio equipment in its possible positions of normal use. It might possibly be necessary to perform a special electromagnetic compatibility (EMC) test.

3.3.4 Protection against electromagnetic and magnetic fields during operation and mounting

Electromagnetic and magnetic fields!

Health hazard for persons with active implantable medical devices (AIMD) such as pacemakers or passive metallic implants.

- Hazards for the above-mentioned groups of persons by electromagnetic and magnetic fields in the immediate vicinity of drive controllers and the associated current-carrying conductors.
- Entering these areas can pose an increased risk to the above-mentioned groups of persons. They should seek advice from their physician.
- If overcome by possible effects on above-mentioned persons during operation of drive controllers and accessories, remove the exposed persons from the vicinity of conductors and devices.

3.3.5 Protection against contact with hot parts

Hot surfaces of components of the electric drive and control system. Risk of burns!

- Do not touch hot surfaces of, for example, braking resistors, heat sinks, supply units and drive controllers, motors, windings and laminated cores!
- According to the operating conditions, temperatures of the surfaces can be **higher than 60 °C (140 °F)** during or after operation.
- Before touching motors after having switched them off, let them cool down for a sufficient period of time. Cooling down can require **up to 140 minutes!** The time required for cooling down is approximately five times the thermal time constant specified in the technical data.
- After switching chokes, supply units and drive controllers off, wait **15 minutes** to allow them to cool down before touching them.
- Wear safety gloves or do not work at hot surfaces.
- For certain applications, and in accordance with the respective safety regulations, the manufacturer of the machine or installation must take measures to avoid injuries caused by burns in the final application. These measures can be, for example: Warnings at the machine or installation, guards (shields or barriers) or safety instructions in the application documentation.

3.3.6 Protection during handling and mounting

Risk of injury by improper handling! Injury by crushing, shearing, cutting, hitting!

- Observe the relevant statutory regulations of accident prevention.
- Use suitable equipment for mounting and transport.
- Avoid jamming and crushing by appropriate measures.
- Always use suitable tools. Use special tools if specified.
- Use lifting equipment and tools in the correct manner.
- Use suitable protective equipment (hard hat, safety goggles, safety shoes, safety gloves, for example).

Safety notes for electric drives and controls

- Do not stand under hanging loads.
- Immediately clean up any spilled liquids from the floor due to the risk of falling!

3.3.7 Battery safety

Batteries consist of active chemicals in a solid housing. Therefore, improper handling can cause injury or property damage.

Risk of injury by improper handling!

- Do not attempt to reactivate low batteries by heating or other methods (risk of explosion and cauterization).
- Do not attempt to recharge the batteries as this may cause leakage or explosion.
- Do not throw batteries into open flames.
- Do not dismantle batteries.
- When replacing the battery/batteries, do not damage the electrical parts installed in the devices.
- Only use the battery types specified for the product.



Environmental protection and disposal! The batteries contained in the product are considered dangerous goods during land, air, and sea transport (risk of explosion) in the sense of the legal regulations. Dispose of used batteries separately from other waste. Observe the national regulations of your country.

3.3.8 Protection against pressurized systems

According to the information given in the Project Planning Manuals, motors and components cooled with liquids and compressed air can be partially supplied with externally fed, pressurized media, such as compressed air, hydraulics oil, cooling liquids and cooling lubricants. Improper handling of the connected supply systems, supply lines or connections can cause injuries or property damage.

Risk of injury by improper handling of pressurized lines!

- Do not attempt to disconnect, open or cut pressurized lines (risk of explosion).
- Observe the respective manufacturer's operating instructions.
- Before dismounting lines, relieve pressure and empty medium.
- Use suitable protective equipment (safety goggles, safety shoes, safety gloves, for example).
- Immediately clean up any spilled liquids from the floor due to the risk of falling!



Environmental protection and disposal! The agents (e.g., fluids) used to operate the product might not be environmentally friendly. Dispose of agents harmful to the environment separately from other waste. Observe the national regulations of your country.

3.4 Explanation of signal words and the Safety alert symbol

The Safety Instructions in the available application documentation contain specific signal words (DANGER, WARNING, CAUTION or NOTICE) and, where required, a safety alert symbol (in accordance with ANSI Z535.6-2011).

The signal word is meant to draw the reader's attention to the safety instruction and identifies the hazard severity.

The safety alert symbol (a triangle with an exclamation point), which precedes the signal words DANGER, WARNING and CAUTION, is used to alert the reader to personal injury hazards.

DANGER

In case of non-compliance with this safety instruction, death or serious injury **will** occur.

WARNING

In case of non-compliance with this safety instruction, death or serious injury **could** occur.

CAUTION

In case of non-compliance with this safety instruction, minor or moderate injury could occur.

NOTICE

In case of non-compliance with this safety instruction, property damage could occur.

4 Technical data

4.1 Description of the specified parameters

General information The torque-speed characteristics and technical data are given for two different temperature models.

- 60K temperature increase on the housing and
- 100K temperature increase on the motor winding



Observe the specified temperatures when selecting technical data! The respective data are marked with **100K** or **60K**.

60K data The 60K data are given for MSK motors under the following conditions:

- Ambient temperature 40 °C
- Insulated construction
- Maximum temperature increase on housing $\Delta T = 60K$
- For motors with optional holding brake, data are always given for motors **with** holding brake.
- Motors with radial shaft sealing ring

100K data The 100K data are given for MSK motors under the following conditions:

- Ambient temperature 40 °C
- Construction **not** insulated (attachment to steel flange $L \times W \times H$ 450×30×350; or $L \times W \times H$ 120×40×100)
- Maximum temperature increase on the winding $\Delta T = 100K$
- For motors with optional holding brake, data are always given for motors **with** holding brake.
- Motors with radial shaft sealing ring



The machine accuracy can be negatively affected by increased linear expansion in 100K-operation. It is recommended to work with 60K data when planning the systems.

Parameters in the data sheet

Designation	Symbol	Unit	Description
Continuous torque at standstill 60K	M_{0_60}	Nm	Continuous torque that can be applied to the motor output shaft at a speed of ($f_{ei} \geq 0.4$ Hz). At $n = 0$: $M_0 = 0.95 \cdot M_{0_60}$
Continuous current at standstill 60K	I_{0_60}	A	Phase current (crest value) of the motor M_{0_60} required for the continuous torque at standstill.
Continuous torque at standstill 100K	M_{0_100}	Nm	Continuous torque that can be applied to the motor output shaft at a speed of ($f_{ei} \geq 0.4$ Hz). At $n = 0$: $M_0 = 0.85 \cdot M_{0_100}$
Continuous current at standstill 100K	$I_{0_100(eff)}$	A	Phase current (crest value) of the motor M_{0_100} required for the continuous torque at standstill.
Continuous torque at standstill surface	M_{0_S}	Nm	Continuous torque that can be applied to the motor output shaft at a speed of ($f_{ei} \geq 0.4$ Hz). At $n = 0$: $M_0 = 0.8 \cdot M_{0_S}$
Continuous current at standstill surface	$I_{0_S(eff)}$	A	Phase current (crest value) of the motor M_{0_S} required for the continuous torque at standstill.
Continuous torque at standstill liquid	M_{0_L}	Nm	Continuous torque that can be applied to the motor output shaft at a speed of ($f_{ei} \geq 0.4$ Hz). At $n = 0$: $M_0 = 0.75 \cdot M_{0_L}$
Continuous current at standstill liquid	$I_{0_L(eff)}$	A	Phase current (crest value) of the motor M_{0_L} required for the continuous torque at standstill.

Technical data

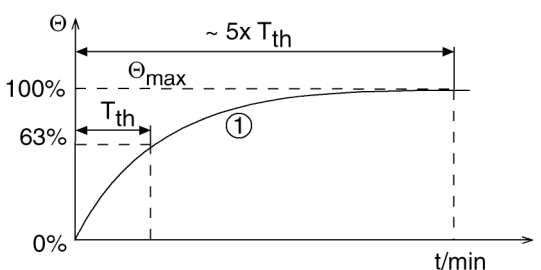
Designation	Symbol	Unit	Description
Maximum torque	M_{\max}	M_{\max}	For maximum current I_{\max} , for approx. 400 ms exchangeable maximum torque. The maximum torque depends on the drive control unit. The only binding maximum torque is that specified in the selection lists.
Maximum current	$I_{\max(\text{eff})}$	A	Maximum, temporarily permissible phase current of the motor winding without adverse effect on the permanent magnet circuit of the motor.
Torque constant at 20 °C	$K_{M,N}$	Nm/A	Ratio of generated torque to motor phase current at motor temperature 20 °C. Valid up to approx. $i = 2 \times I_{0,60}$.
Voltage constant at 20 °C	K_{EMK_1000}	V/min ⁻¹	Root-mean-square value of the induced motor voltage at a motor temperature of 20 °C and 1,000 revolutions per minute.
Winding resistance at 20 °C	R_{12}	Ohm	Measured winding resistance among two strands.
Winding inductivity	L_{12}	mH	Measured inductivity between two strands.
Leakage capacitance	C_{dis}	nF	Capacity of short-circuited power connections U, V, W against the motor housing.
Number of pole pairs	p	-	Quantity of pole pairs of the motor.
Moment of inertia of the rotor	J_{red}	kgm ²	Moment of inertia of the rotor without optional holding brake. Moment of inertia of the holding brake must be added as well.
Thermal time constant	T_{th}	min	<p>Duration of the temperature rise to 63% of the final temperature of the motor housing at motor load with permissible S1 continuous torque. The thermal time constant is determined by the cooling type used.</p>  <p>①: time course of the temperature on the motor housing Θ_{\max}: Highest temperature (motor housing) T_{th}: Thermal time constant</p> <p>Duration of the temperature rise to 63% of the final temperature of the motor housing at motor load with permissible S1 continuous torque. The thermal time constant is determined by the cooling type used.</p>
Maximum speed	n_{\max}	min ⁻¹	Maximum permissible speed of the motor.
Sound pressure level	L_P	dB(A)	Determined values for 1 m distance from motor to measuring point.
Mass	m	kg	Mass of the motor.
Ambient temperature during operation	T_{amb}	°C	0 ... 40 °C
Protection class	-	-	IP protection class acc. to EN 60034
Insulation class	-	-	Insulation class according to DIN EN 60034-1
Holding torque	M_4	Nm	Transmittable holding torque of the holding brake.
Rated voltage	U_N	V	Input voltage of the holding brake.
Rated current	I_N	A	Current consumption of the holding brake.
Connection time	t_1	ms	Time until the holding brake is closed.
Disconnection time	t_2	ms	Time until the holding brake is released.
Moment of inertia of the brake	J_{Br}	kgm ²	Moment of inertia of the holding brake, must be added to the moment of inertia of the motors to determine the total moment of inertia.

Operation mode MSK motors are documented according to test criteria and measuring methods in compliance with EN 60034-1. The specified characteristic curves correspond to operation modes S1 or S3.

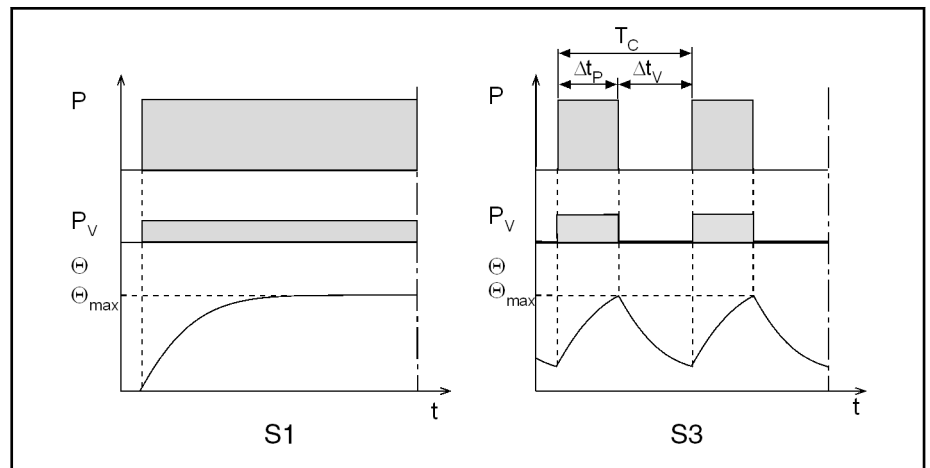

P Load
P_V electrical losses
Θ Temperature
Θ_{max} maximum temperature (motor housing)
t Time
T_C Cycle duration
Δt_P Operating time under constant load
Δt_V Idle time

Fig. 4-1: Operation modes according to EN 60034-1:1998

Duty cycle Operation mode S3 is specified along with the duty cycle (DC) %. The duty cycle is calculated:

$$ED = \frac{\Delta t_P}{T_C} \cdot 100\%$$

ED relative duty cycle in %
Δt_P Operating time under constant load

Fig. 4-2: Relative duty cycle

The values specified in the documentation are determined on the basis of the following values:

Cycle duration: 10 min

Duty cycle DC: 25%

Technical data

Speed-torque characteristic curve

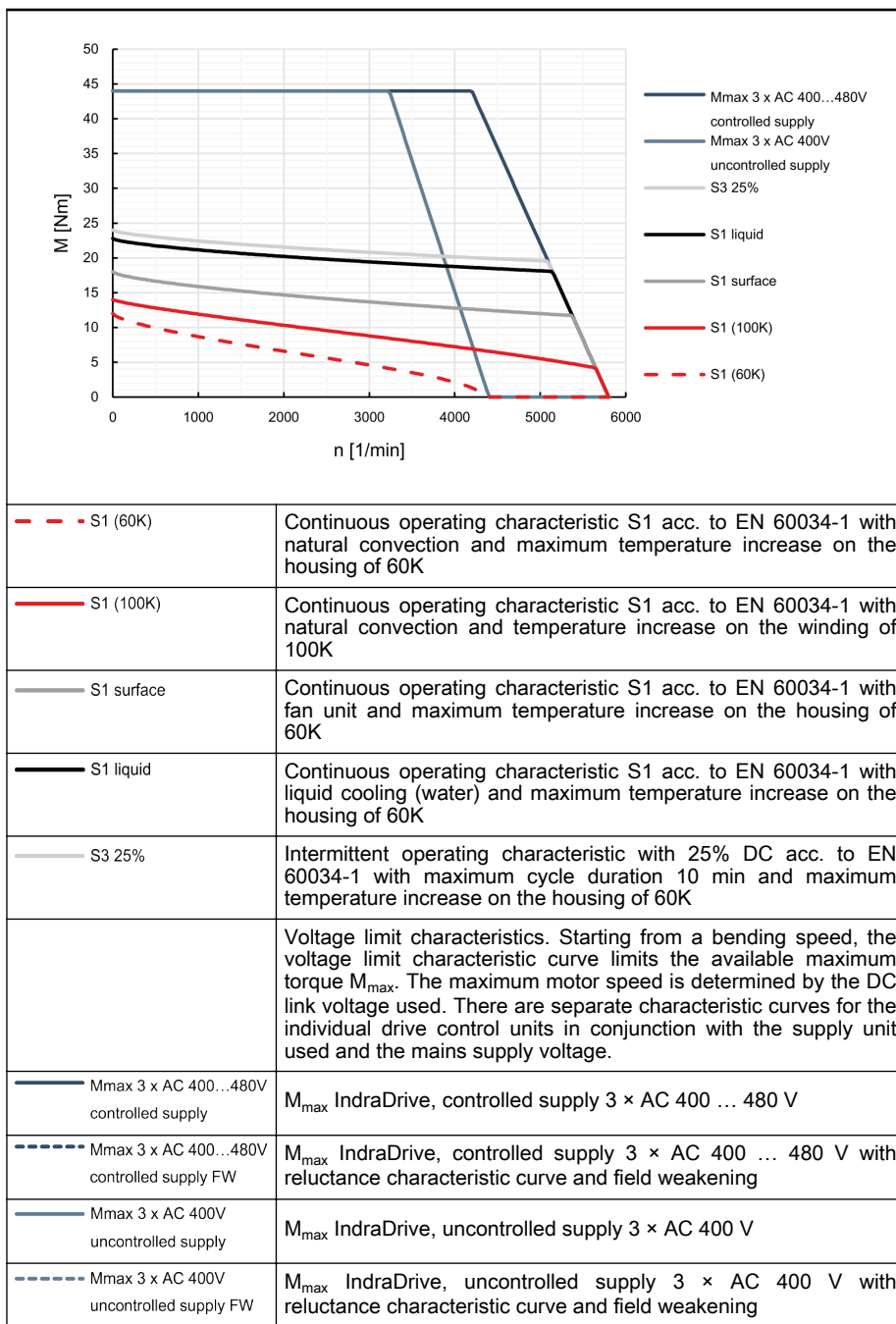

Tab. 4-1: Characteristic curves of motor (example)

4.2 IndraSize

The IndraSize software makes it easy to dimension drive controllers, motors and mechanical gears. The engineering tool covers the entire range of Rexroth drives and motors. Calculate the characteristic curves for your application with IndraSize: www.boschrexroth.com/indraSize

4.3 Technical data encoder MSK motors

Designation	Symbol	Unit	S1	M1	S2	M2	S3	M3
Interface			Hiperface		EnDat 2.1		Hiperface	
Encoder design			Singleturn absolute	Multiturn absolute	Singleturn absolute	Multiturn absolute	Singleturn absolute	Multiturn absolute
Distinguishable revolutions			1	4,096	1	4,096	1	4,096
Signal periods			128		2,048		16	
System accuracy		Angular seconds	±120		±20		±520	
Output signal			1Vss					
Maximum encoder speed		min ⁻¹	12,000	9,000	15,000	12,000		
Max. current consumption	I _{Encoder}	mA	60		150	250	50	
Supply voltage	V _{CC Encoder}	V	7...12		3.6...14		7...12	

Tab. 4-2: Technical data MSK encoder

Calculate position resolution

The actual **position resolution** can be done for every encoder type according to the following calculation.

Calculation example: "Position resolution for M1 encoder"

from table:

Distinguishable revolutions: **4,096**

Number of lines **128**

out of documentation about the controllers:

Encoder resolution ¹⁾: **13 bit**

Position resolution = number of lines x resolution of encoder x distinguishable revolutions

Position resolution = $128 \times 2^{13} \times 4,096 = 4,294,967,296$ Information

¹⁾ Encoder resolution depends from the connected controller.

Encoder Singleturn S1, S2, S3

These encoders permit absolute, indirect position recording within **one** mechanical rotation. The encoders replace separate incremental encoders on the motor.



After a power failure or after the first POWER ON, the axis must always at first be moved to its home position.

Exception: Applications in which the maximum working path is within one mechanical rotation of the motor.

Encoder Multiturn absolute M1, M2, M3

These encoders permit absolute, indirect position recording within **4,096** mechanical rotations. The encoders replace a separate absolute value encoder on the motor. With this encoder version, the absolute position of the axis is preserved even after a switch-off.

Technical data

4.4 Technical data holding brakes

Type	Holding torque	Rated volt- age ¹⁾	Rated current	Maximum con- nection time	Maximum dis- connection time	Moment of in- ertia of the holding brake
	M ₄ Nm	U _N V	I _N A	t ₁ ms	t ₂ ms	J _{br} kg*m ²
MSK030B-____-____-1-____	1.00	24	0.40	14	28	0.0000100
MSK030C-____-____-1-____	1.00	24	0.40	14	28	0.0000100
MSK040B-____-____-1-____	4.00	24	0.50	25	35	0.0000230
MSK040C-____-____-1-____	4.00	24	0.50	25	35	0.0000230
MSK043C-____-____-1-____	4.00	24	0.50	25	35	0.0000230
MSK050B-____-____-1-____	6.00	24	0.65	20	60	0.0001070
MSK050C-____-____-1-____	6.00	24	0.65	20	60	0.0001070
MSK060B-____-____-1-____	10.00	24	0.96	20	40	0.0000600
MSK060C-____-____-1-____	10.00	24	0.96	20	40	0.0000600
MSK061B-____-____-1-____	10.00	24	0.96	25	40	0.0000600
MSK061C-____-____-1-____	10.00	24	0.96	25	40	0.0000600
MSK070C-____-____-1-____	23.00	24	0.79	35	180	0.0003000
MSK070D-____-____-1-____	23.00	24	0.79	35	180	0.0003000
MSK070E-____-____-1-____	23.00	24	0.79	35	180	0.0003000
MSK071C-____-____-1-____	23.00	24	0.79	35	180	0.0003000
MSK071C-____-____-2-____	30.00	24	0.94	40	270	0.0010600
MSK071D-____-____-1-____	23.00	24	0.79	35	180	0.0003000
MSK071D-____-____-2-____	30.00	24	0.94	40	270	0.0010600
MSK071E-____-____-1-____	23.00	24	0.79	35	180	0.0003000
MSK071E-____-____-2-____	30.00	24	0.94	40	270	0.0010600
MSK075C-____-____-1-____	23.00	24	0.79	40	270	0.0003000
MSK075C-____-____-2-____	30.00	24	0.94	40	270	0.0010600
MSK075D-____-____-1-____	23.00	24	0.79	40	270	0.0003000
MSK075D-____-____-2-____	30.00	24	0.94	40	270	0.0010600
MSK075E-____-____-1-____	23.00	24	0.79	40	270	0.0003000
MSK075E-____-____-2-____	30.00	24	0.94	40	270	0.0010600
MSK076C-____-____-1-____	11.00	24	0.71	10	50	0.0001660
MSK100A-____-____-1-____	32.00	24	0.93	15	115	0.0012420
MSK100B-____-____-1-____	32.00	24	0.93	15	115	0.0012420
MSK100B-____-____-2-____	70.00	24	1.29	53	97	0.0030000
MSK100C-____-____-1-____	32.00	24	0.93	15	115	0.0012420
MSK100C-____-____-2-____	70.00	24	1.29	53	97	0.0030000
MSK100D-____-____-1-____	32.00	24	0.93	15	115	0.0012420
MSK100D-____-____-2-____	70.00	24	1.29	53	97	0.0030000
MSK101C-____-____-2-____	70.00	24	1.29	53	97	0.0030000
MSK101D-____-____-2-____	70.00	24	1.29	53	97	0.0030000
MSK101D-____-____-3-____	120.00	24	1.46	80	150	0.0057500
MSK101E-____-____-2-____	70.00	24	1.29	53	97	0.0030000

1) Tolerance ± 10%

Technical data

Type	Holding torque	Rated voltage ¹⁾	Rated current	Maximum connection time	Maximum disconnection time	Moment of inertia of the holding brake
	M ₄ Nm	U _N V	I _N A	t ₁ ms	t ₂ ms	J _{br} kg*m ²
MSK101E-____-____-____3-____	120.00	24	1.46	80	150	0.0057500
MSK103A-____-____-____1-____	33.00	24	0.94	40	270	0.0010600
MSK103B-____-____-____1-____	33.00	24	0.94	40	270	0.0010600
MSK131B-____-____-____1-____	100.00	24	2.00	70	190	0.0053000
MSK131D-____-____-____1-____	100.00	24	2.00	70	190	0.0053000
MSK131D-____-____-____2-____	240.00	24	1.87	130	300	0.0188000
1) Tolerance ± 10%						

Tab. 4-3: Holding brakes - Technical data (optional)

Technical data

4.5 MSK030B Technical data

Designation	Symbol	Unit	MSK030B-0900-NN
Continuous torque at standstill 60 K	M_{0_60}	Nm	0.4
Continuous current at standstill 60 K	$I_{0_60(\text{eff})}$	A	1.5
Continuous torque at standstill 100 K	M_{0_100}	Nm	0.4
Continuous current at standstill 100 K	$I_{0_100(\text{eff})}$	A	1.7
Maximum torque	M_{max}	Nm	1.8
Maximum current	$I_{\text{max}(\text{eff})}$	A	6.8
Torque constant at 20 °C	K_{M_N}	Nm/A	0.29
Voltage constant at 20 °C ¹⁾	K_{EMK_1000}	V/1000 min ⁻¹	17.9
Winding resistance at 20 °C	R_{12}	Ohm	7.2
Winding inductance	L_{12}	mH	8.1
Leakage capacitance of the component	C_{dis}	nF	0.7
Number of pole pairs	p	-	3
Moment of inertia of rotor	J_{red}	kg*m ²	0.00001
Thermal time constant	$T_{\text{th_nom}}$	min	19.0
Maximum speed (electric)	$n_{\text{max el}}$	min ⁻¹	9000
Sound pressure level	L_p	dB[A]	< 75
Mass ²⁾	m	kg	1.3 (1.6)
Ambient temperature during operation	T_{amb}	°C	0 ... 40
Protection class (EN 60034-5)	-	-	IP65
Thermal class (EN 60034-1)	T.CL.	-	155

Last amended: 2014-01-21

- 1) Manufacturing tolerance $\pm 5\%$
 2) (...) Motors with holding brake 1, 2, ...
 Tab. 4-4: Technical data

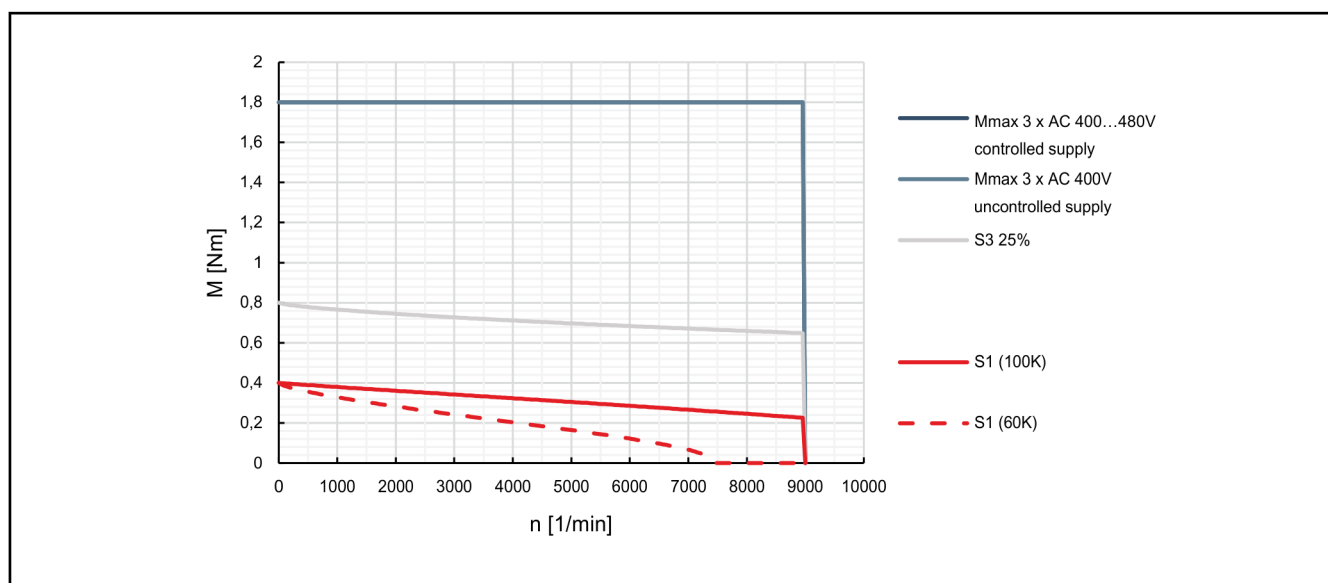

Fig. 4-3: Characteristic curves of motor MSK030B-0900

4.6 MSK030C Technical data

Designation	Symbol	Unit	MSK030C-0900-NN
Continuous torque at standstill 60 K	M_{0_60}	Nm	0.8
Continuous current at standstill 60 K	$I_{0_60(\text{eff})}$	A	1.5
Continuous torque at standstill 100 K	M_{0_100}	Nm	0.9
Continuous current at standstill 100 K	$I_{0_100(\text{eff})}$	A	1.7
Maximum torque	M_{max}	Nm	4.0
Maximum current	$I_{\text{max}(\text{eff})}$	A	6.8
Torque constant at 20 °C	K_{M_N}	Nm/A	0.58
Voltage constant at 20 °C ¹⁾	$K_{\text{EMK_1000}}$	V/1000 min ⁻¹	35.6
Winding resistance at 20 °C	R_{12}	Ohm	9.8
Winding inductance	L_{12}	mH	14.1
Leakage capacitance of the component	C_{dis}	nF	1.3
Number of pole pairs	p	-	3
Moment of inertia of rotor	J_{red}	kg*m ²	0.00003
Thermal time constant	$T_{\text{th_nom}}$	min	12.0
Maximum speed (electric)	$n_{\text{max el}}$	min ⁻¹	9000
Sound pressure level	L_P	dB[A]	< 75
Mass ²⁾	m	kg	1.9 (2.1)
Ambient temperature during operation	T_{amb}	°C	0 ... 40
Protection class (EN 60034-5)	-	-	IP65
Thermal class (EN 60034-1)	T.CL.	-	155

Last amended: 2014-01-21

- 1) Manufacturing tolerance ±5%
 2) (...) Motors with holding brake 1, 2, ...
 Tab. 4-5: Technical data

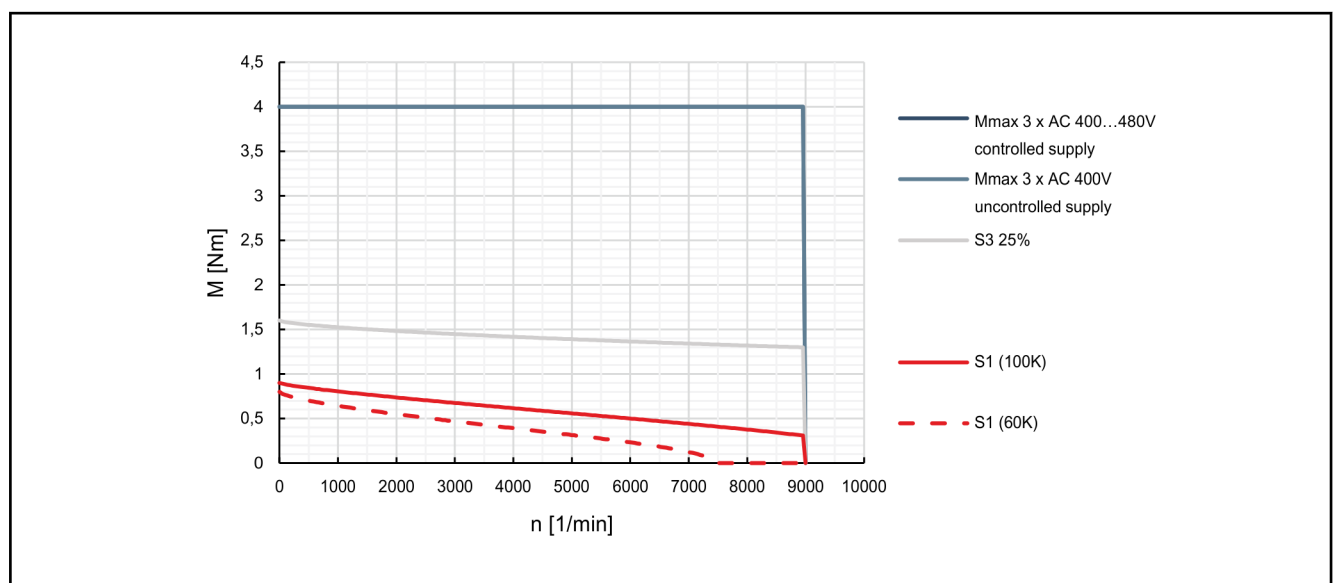

Fig. 4-4: Characteristic curves of motor MSK030C-0900

Technical data

4.7 MSK040B Technical data

Designation	Symbol	Unit	MSK040B-0450-NN	MSK040B-0600-NN
Continuous torque at standstill 60 K	$M_{0,60}$	Nm	1.7	
Continuous current at standstill 60 K	$I_{0,60(\text{eff})}$	A	1.5	2.0
Continuous torque at standstill 100 K	$M_{0,100}$	Nm	1.9	
Continuous current at standstill 100 K	$I_{0,100(\text{eff})}$	A	1.7	2.2
Maximum torque	M_{max}	Nm	5.1	
Maximum current	$I_{\text{max}(\text{eff})}$	A	6.0	8.0
Torque constant at 20 °C	$K_{M,N}$	Nm/A	1.26	0.92
Voltage constant at 20 °C ¹⁾	$K_{EMK,1000}$	V/1000 min ⁻¹	77.8	58.5
Winding resistance at 20 °C	R_{12}	Ohm	14.7	8.4
Winding inductance	L_{12}	mH	64.7	35.4
Leakage capacitance of the component	C_{dis}	nF	1.3	1.5
Number of pole pairs	p	-	4	
Moment of inertia of rotor	J_{red}	kg*m ²	0.00010	
Thermal time constant	$T_{\text{th,nom}}$	min	13.0	
Maximum speed (electric)	$n_{\text{max el}}$	min ⁻¹	6000	7500
Sound pressure level	L_p	dB[A]	< 75	
Mass ²⁾	m	kg	2.8 (3.1)	
Ambient temperature during operation	T_{amb}	°C	0 ... 40	
Protection class (EN 60034-5)	-	-	IP65	
Thermal class (EN 60034-1)	T.CL.	-	155	

Last amended: 2014-04-29

- 1) Manufacturing tolerance $\pm 5\%$
 2) (...) Motors with holding brake 1, 2, ...
 Tab. 4-6: MSK - Technical data

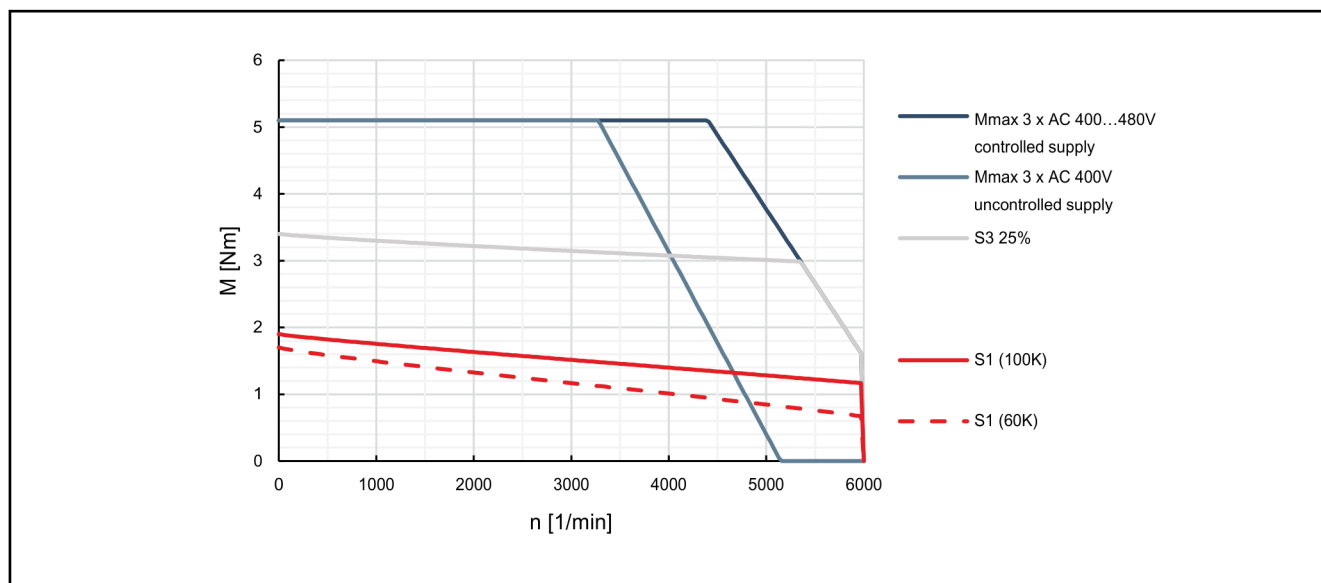

Fig. 4-5: Characteristic curves of motor MSK040B-0450

Technical data

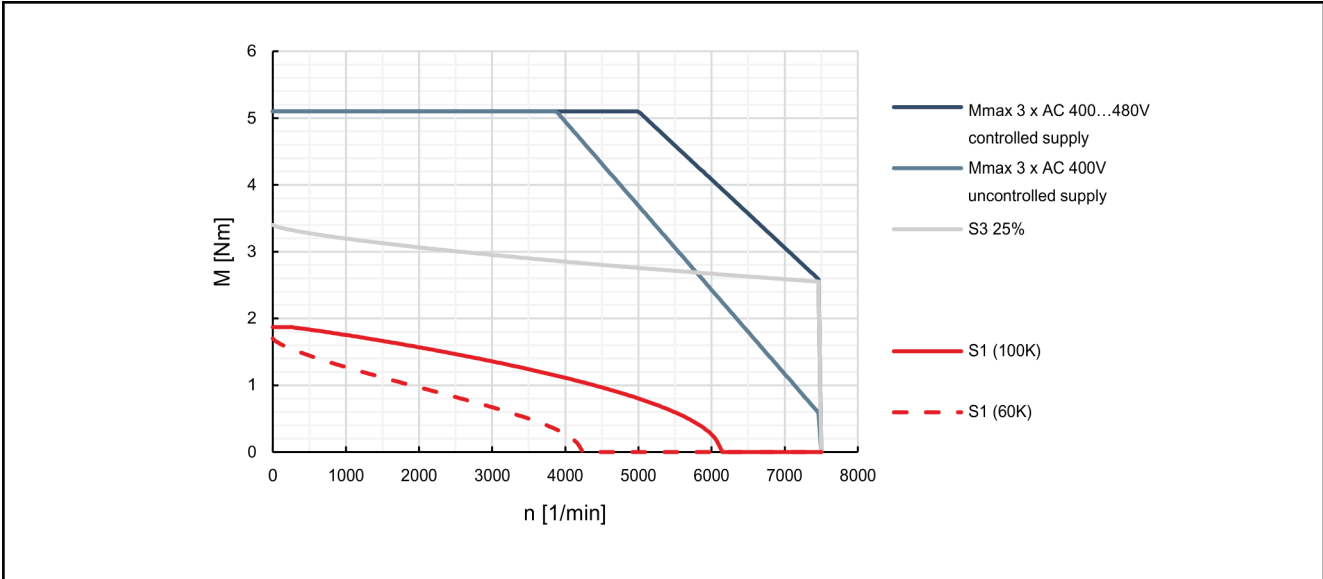

Fig. 4-6: Characteristic curves of motor MSK040B-0600

Technical data

4.8 MSK040C Technical data

Designation	Symbol	Unit	MSK040C-0450-NN	MSK040C-0600-NN
Continuous torque at standstill 60 K	M_{0_60}	Nm	2.7	
Continuous current at standstill 60 K	$I_{0_60(\text{eff})}$	A	2.4	3.1
Continuous torque at standstill 100 K	M_{0_100}	Nm	3.1	
Continuous current at standstill 100 K	$I_{0_100(\text{eff})}$	A	3.1	4.7
Maximum torque	M_{max}	Nm	8.1	
Maximum current	$I_{\text{max}(\text{eff})}$	A	9.6	12.4
Torque constant at 20 °C	K_{M_N}	Nm/A	1.25	0.95
Voltage constant at 20 °C ¹⁾	K_{EMK_1000}	V/1000 min ⁻¹	76.7	58.2
Winding resistance at 20 °C	R_{12}	Ohm	7.4	3.9
Winding inductance	L_{12}	mH	37.9	21.3
Leakage capacitance of the component	C_{dis}	nF	2.0	
Number of pole pairs	p	-	4	
Moment of inertia of rotor	J_{red}	kg*m ²	0.00014	
Thermal time constant	$T_{\text{th_nom}}$	min	16.0	
Maximum speed (electric)	$n_{\text{max el}}$	min ⁻¹	6000	7500
Sound pressure level	L_p	dB[A]	< 75	
Mass ²⁾	m	kg	3.6 (3.9)	
Ambient temperature during operation	T_{amb}	°C	0 ... 40	
Protection class (EN 60034-5)	-	-	IP65	
Thermal class (EN 60034-1)	T.CL.	-	155	

Last amended: 2014-01-21

- 1) Manufacturing tolerance $\pm 5\%$
 2) (...) Motors with holding brake 1, 2, ...
 Tab. 4-7: MSK - Technical data (standard cooling)

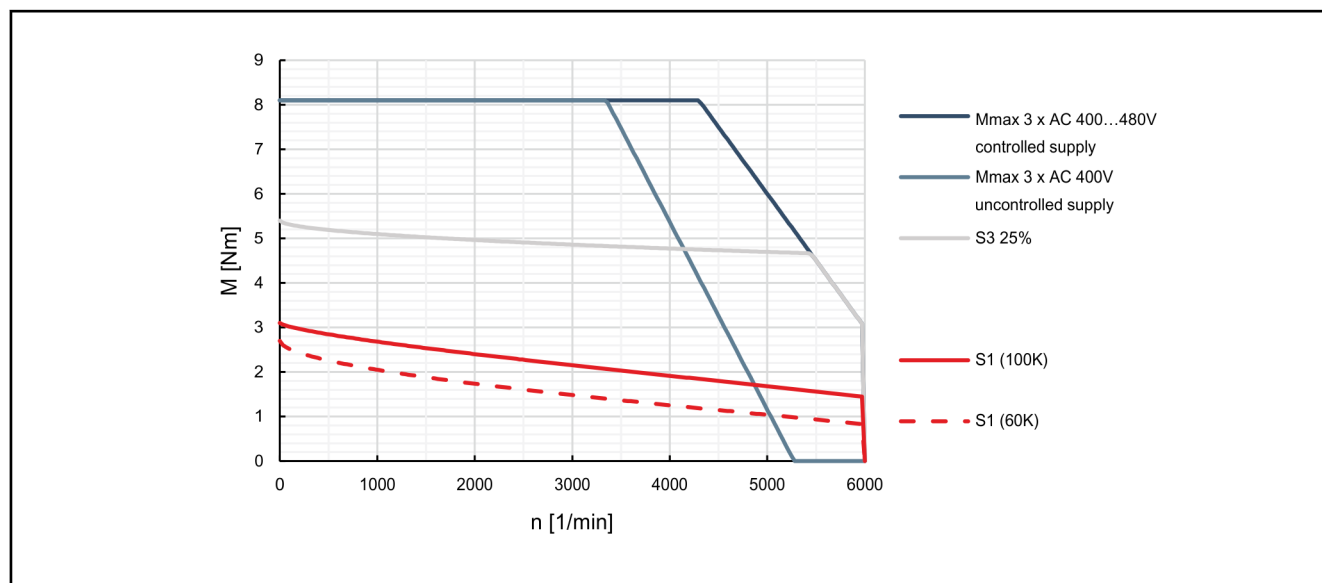

Fig. 4-7: Characteristic curves of motor MSK040C-0450

Technical data

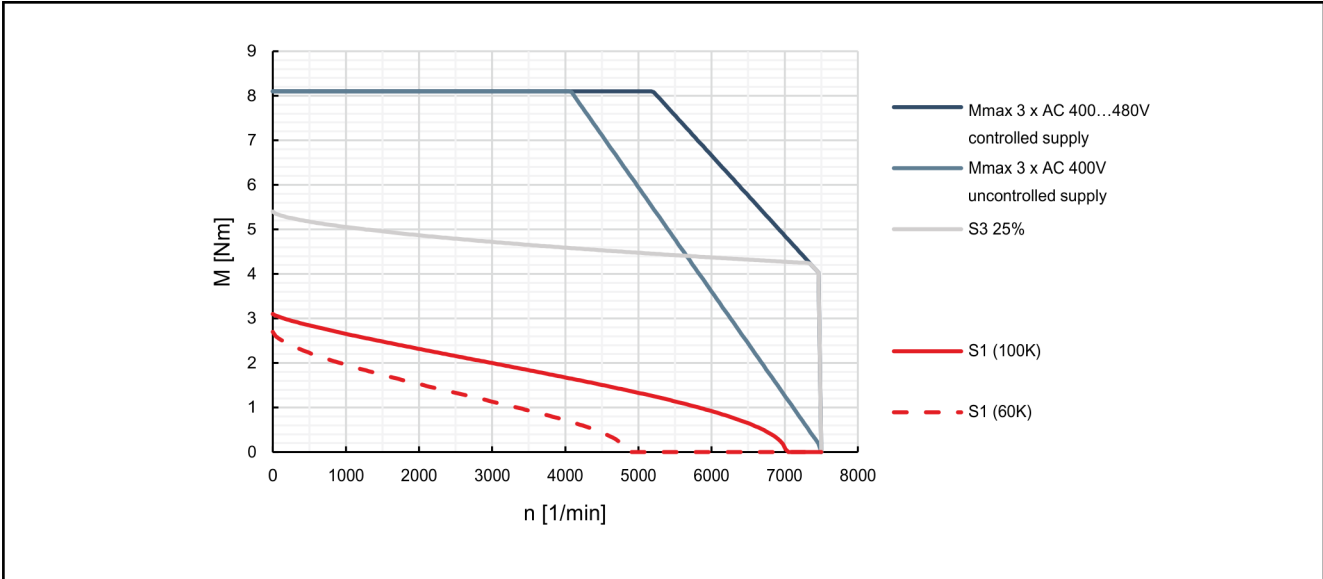

Fig. 4-8: Characteristic curves of motor MSK040C-0600

Technical data

4.9 MSK043C Technical data

Designation	Symbol	Unit	MSK043C-0600-NN
Continuous torque at standstill 60 K	M_{0_60}	Nm	2.7
Continuous current at standstill 60 K	$I_{0_60(\text{eff})}$	A	3.6
Continuous torque at standstill 100 K	M_{0_100}	Nm	3.1
Continuous current at standstill 100 K	$I_{0_100(\text{eff})}$	A	4.3
Maximum torque	M_{max}	Nm	12.5
Maximum current	$I_{\text{max}(\text{eff})}$	A	18.5
Torque constant at 20 °C	K_{M_N}	Nm/A	0.78
Voltage constant at 20 °C ¹⁾	K_{EMK_1000}	V/1000 min ⁻¹	48.0
Winding resistance at 20 °C	R_{12}	Ohm	2.75
Winding inductance	L_{12}	mH	13.4
Leakage capacitance of the component	C_{dis}	nF	2.1
Number of pole pairs	p	-	4
Moment of inertia of rotor	J_{red}	kg*m ²	0.00008
Thermal time constant	$T_{\text{th_nom}}$	min	17.0
Maximum speed (electric)	$n_{\text{max el}}$	min ⁻¹	7500
Sound pressure level	L_p	dB[A]	< 75
Mass ²⁾	m	kg	3.6 (3.9)
Ambient temperature during operation	T_{amb}	°C	0 ... 40
Protection class (EN 60034-5)	-	-	IP65
Thermal class (EN 60034-1)	T.CL.	-	155

Last amended: 2014-01-21

- 1) Manufacturing tolerance ±5%
 2) (...) Motors with holding brake 1, 2, ...
 Tab. 4-8: MSK - Technical data

Technical data

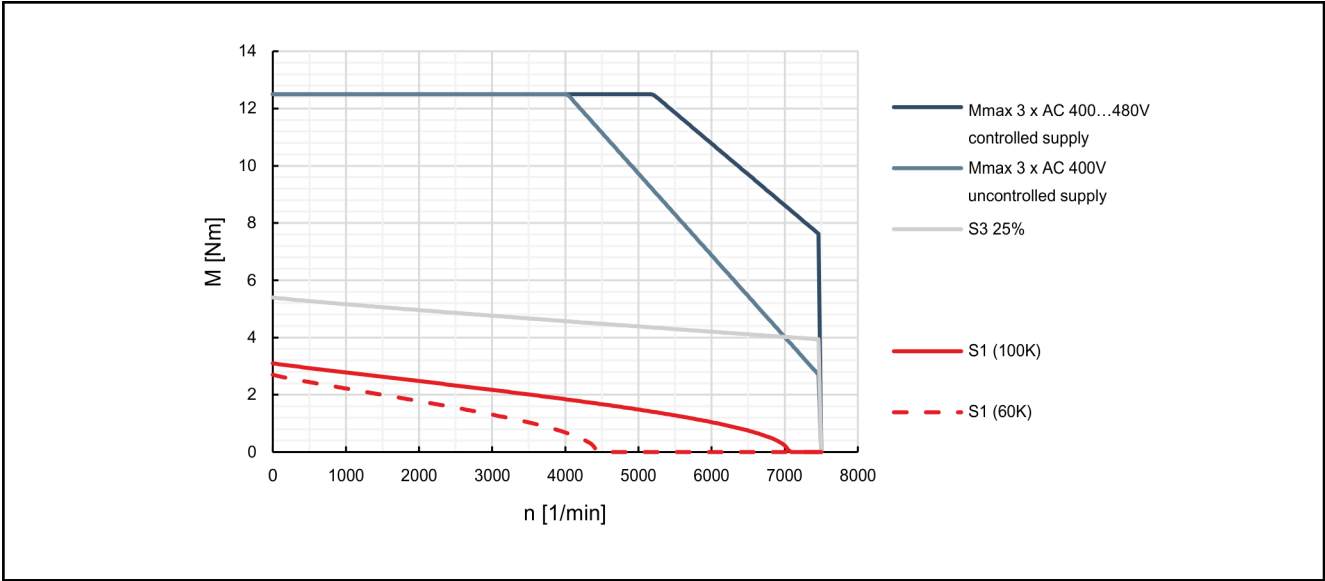

Fig. 4-9: Characteristic curves of motor MSK043C-0600

Technical data

4.10 MSK050B Technical data

Designation	Symbol	Unit	MSK050B-0300-NN	MSK050B-0450-NN	MSK050B-0600-NN
Continuous torque at standstill 60 K	M_{0_60}	Nm	3.0		
Continuous current at standstill 60 K	$I_{0_60(\text{eff})}$	A	1.8	2.8	3.7
Continuous torque at standstill 100 K	M_{0_100}	Nm	3.4		
Continuous current at standstill 100 K	$I_{0_100(\text{eff})}$	A	2.0	3.2	4.2
Maximum torque	M_{max}	Nm	9.0		
Maximum current	$I_{\text{max}(\text{eff})}$	A	7.2	11.2	14.8
Torque constant at 20 °C	K_{M_N}	Nm/A	1.80	1.20	0.90
Voltage constant at 20 °C ¹⁾	K_{EMK_1000}	V/1000 min ⁻¹	111.0	73.5	55.0
Winding resistance at 20 °C	R_{12}	Ohm	13	5.7	3.3
Winding inductance	L_{12}	mH	76.4	33.6	19.9
Leakage capacitance of the component	C_{dis}	nF	2.1	1.4	2.1
Number of pole pairs	p	-	4		
Moment of inertia of rotor	J_{red}	kg*m ²	0.00028		
Thermal time constant	$T_{\text{th_nom}}$	min	8.0		
Maximum speed (electric)	$n_{\text{max el}}$	min ⁻¹	4300	6000	
Sound pressure level	L_p	dB[A]	< 75		
Mass ²⁾	m	kg	4.0 (4.9)		
Ambient temperature during operation	T_{amb}	°C	0 ... 40		
Protection class (EN 60034-5)	-	-	IP65		
Thermal class (EN 60034-1)	T.CL.	-	155		

Last amended: 2014-01-21

- 1) Manufacturing tolerance $\pm 5\%$
 2) (...) Motors with holding brake 1, 2, ...
 Tab. 4-9: Technical data

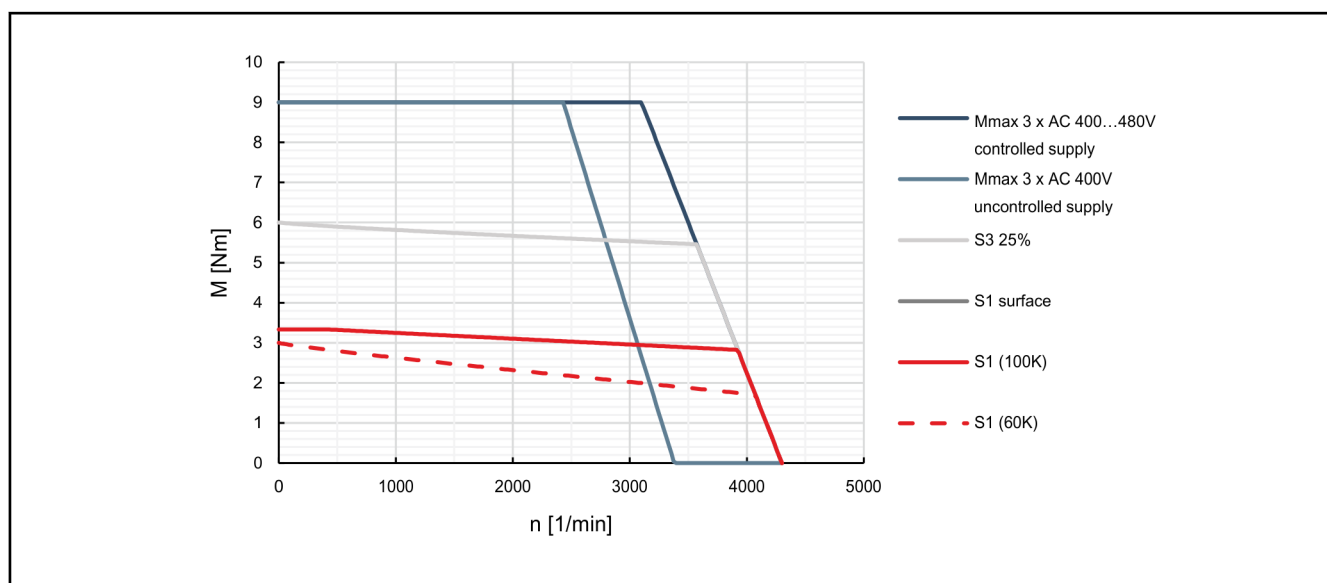

Fig. 4-10: Characteristic curves of motor MSK050B-0300

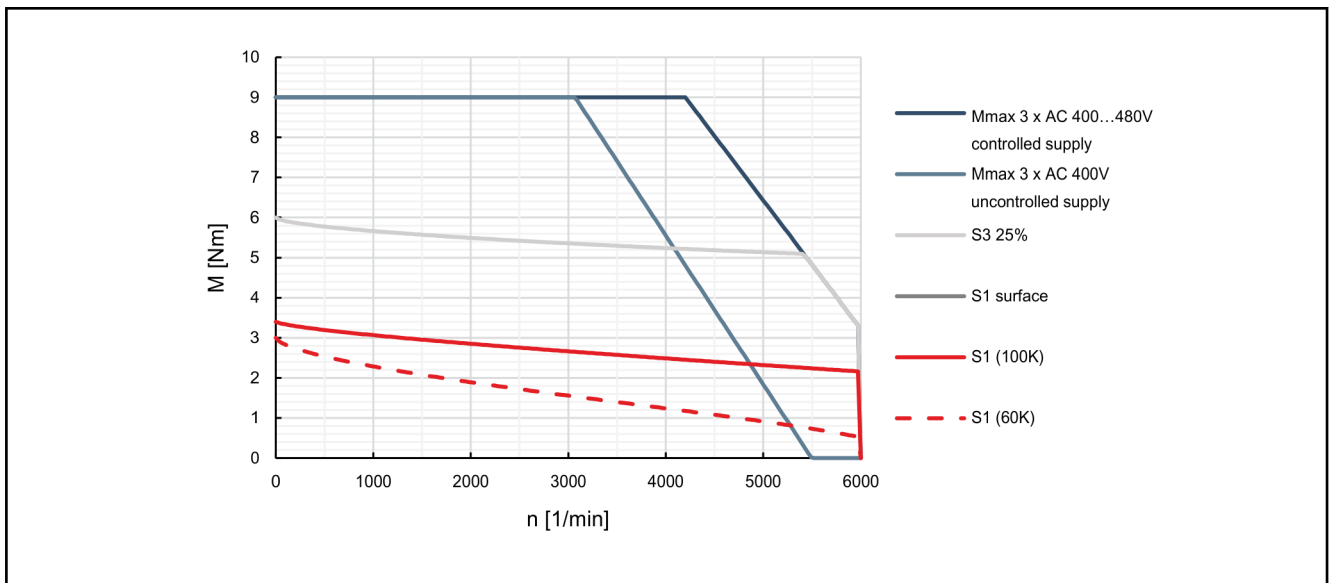

Fig. 4-11: Characteristic curves of motor MSK050B-0450

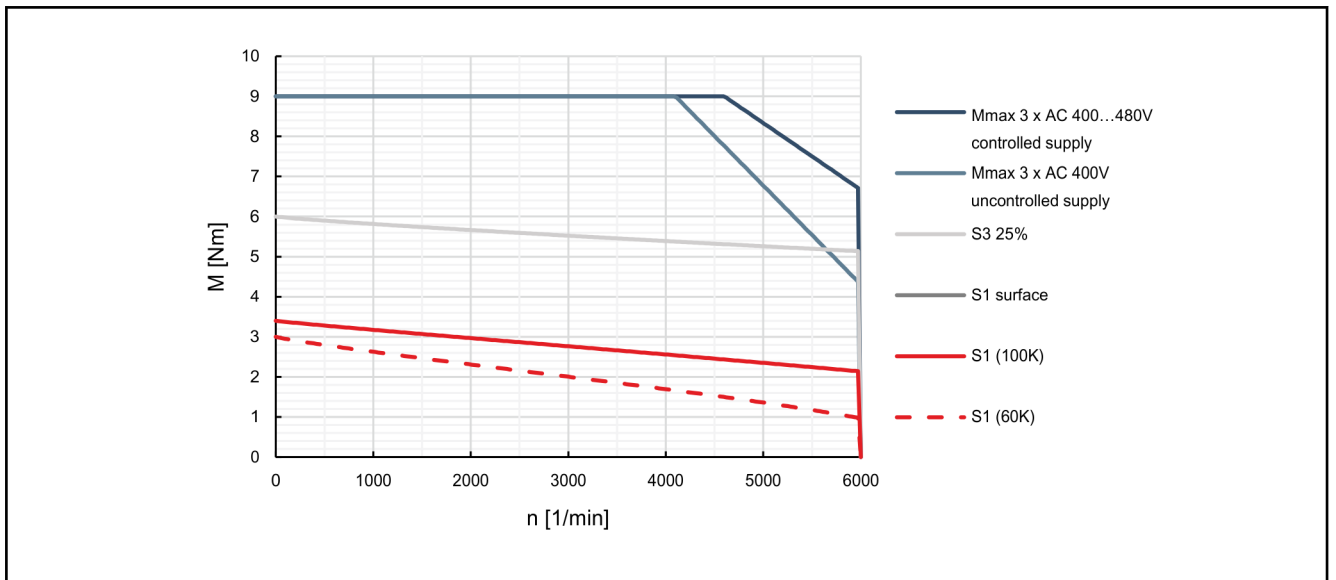

Fig. 4-12: Characteristic curves of motor MSK050B-0600

Technical data

4.11 MSK050C Technical data

Designation	Symbol	Unit	MSK050C-0300-NN	MSK050C-0450-NN	MSK050C-0600-NN
Continuous torque at standstill 60 K	M_{0_60}	Nm	5.0		
Continuous current at standstill 60 K	$I_{0_60(\text{eff})}$	A	3.1	4.7	6.2
Continuous torque at standstill 100 K	M_{0_100}	Nm	5.5		
Continuous current at standstill 100 K	$I_{0_100(\text{eff})}$	A	3.4	5.2	6.8
Maximum torque	M_{max}	Nm	15.0		
Maximum current	$I_{\text{max}(\text{eff})}$	A	12.4	18.8	24.8
Torque constant at 20 °C	K_{M_N}	Nm/A	1.77	1.16	0.89
Voltage constant at 20 °C ¹⁾	K_{EMK_1000}	V/1000 min ⁻¹	109.0	71.5	55.0
Winding resistance at 20 °C	R_{12}	Ohm	6.6	3.2	1.7
Winding inductance	L_{12}	mH	46.1	20.2	11
Leakage capacitance of the component	C_{dis}	nF	2.6	2.4	2.6
Number of pole pairs	p	-	4		
Moment of inertia of rotor	J_{red}	kg*m ²	0.00033		
Thermal time constant	$T_{\text{th_nom}}$	min	14.0		
Maximum speed (electric)	$n_{\text{max el}}$	min ⁻¹	4700	6000	
Sound pressure level	L_p	dB[A]	< 75		
Mass ²⁾	m	kg	5.4 (6.3)		
Ambient temperature during operation	T_{amb}	°C	0 ... 40		
Protection class (EN 60034-5)	-	-	IP65		
Thermal class (EN 60034-1)	T.CL.	-	155		

Last amended: 2014-01-21

- 1) Manufacturing tolerance $\pm 5\%$
 2) (...) Motors with holding brake 1, 2, ...
 Tab. 4-10: MSK - Technical data

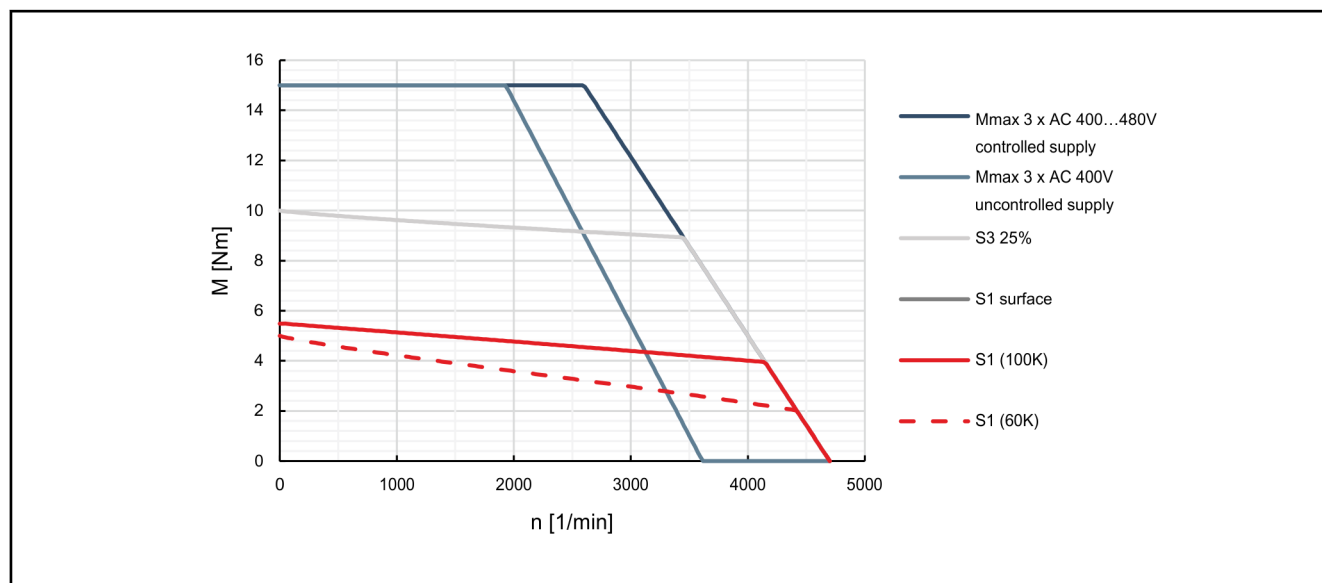

Fig. 4-13: Characteristic curves of motor MSK050C-0300

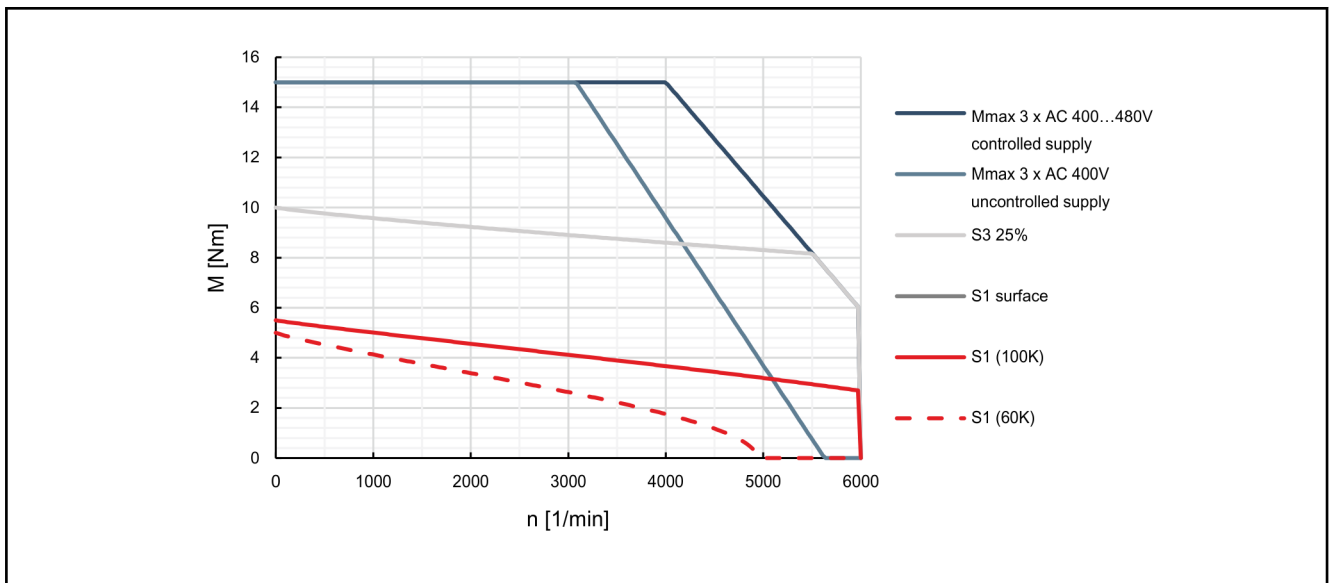

Fig. 4-14: Characteristic curves of motor MSK050C-0450

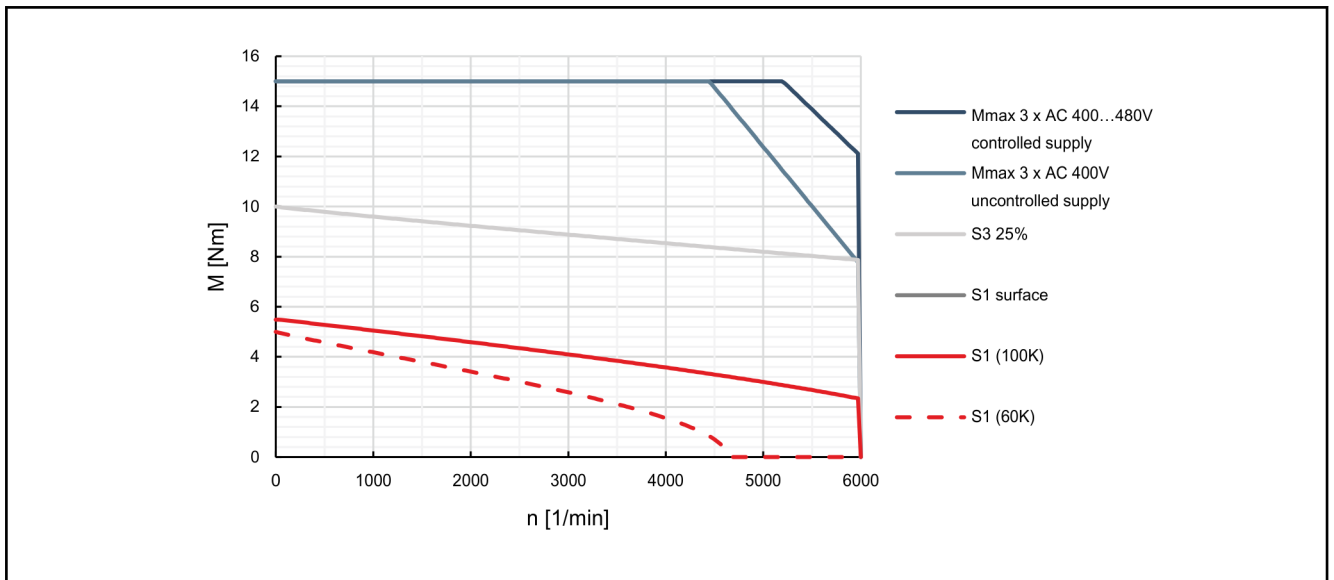

Fig. 4-15: Characteristic curves of motor MSK050C-0600

Technical data

4.12 MSK060B Technical data

Designation	Symbol	Unit	MSK060B-0300-NN	MSK060B-0600-NN
Continuous torque at standstill 60 K	M_{0_60}	Nm	5.0	
Continuous current at standstill 60 K	$I_{0_60(\text{eff})}$	A	3.0	6.1
Continuous torque at standstill 100 K	M_{0_100}	Nm	5.5	
Continuous current at standstill 100 K	$I_{0_100(\text{eff})}$	A	3.3	6.7
Maximum torque	M_{max}	Nm	15.0	
Maximum current	$I_{\text{max}(\text{eff})}$	A	12.0	24.4
Torque constant at 20 °C	K_{M_N}	Nm/A	1.85	0.90
Voltage constant at 20 °C ¹⁾	K_{EMK_1000}	V/1000 min ⁻¹	113.5	55.2
Winding resistance at 20 °C	R_{12}	Ohm	7.3	1.85
Winding inductance	L_{12}	mH	73	18
Leakage capacitance of the component	C_{dis}	nF	2.1	
Number of pole pairs	p	-	4	
Moment of inertia of rotor	J_{red}	kg*m ²	0.00048	
Thermal time constant	$T_{\text{th_nom}}$	min	16.0	
Maximum speed (electric)	$n_{\text{max el}}$	min ⁻¹	4800	6000
Sound pressure level	L_p	dB[A]	< 75	
Mass ²⁾	m	kg	5.7 (6.4)	
Ambient temperature during operation	T_{amb}	°C	0 ... 40	
Protection class (EN 60034-5)	-	-	IP65	
Thermal class (EN 60034-1)	T.CL.	-	155	

Last amended: 2014-01-21

- 1) Manufacturing tolerance $\pm 5\%$
 2) (...) Motors with holding brake 1, 2, ...
 Tab. 4-11: Technical data

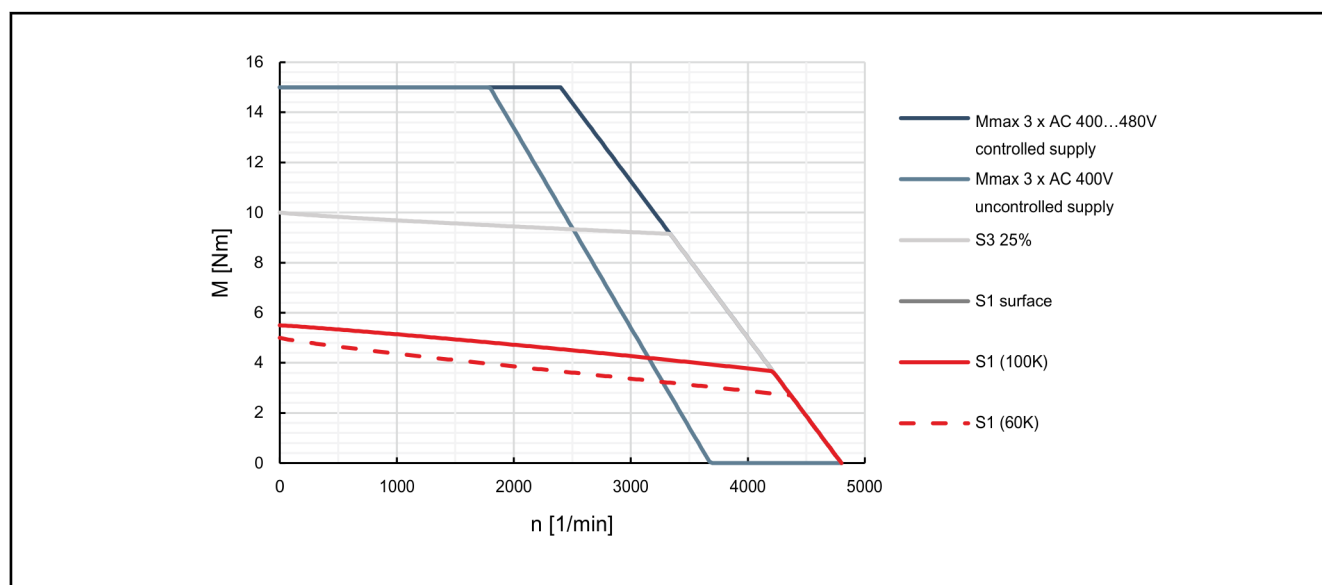

Fig. 4-16: Characteristic curves of motor MSK060B-0300

Technical data

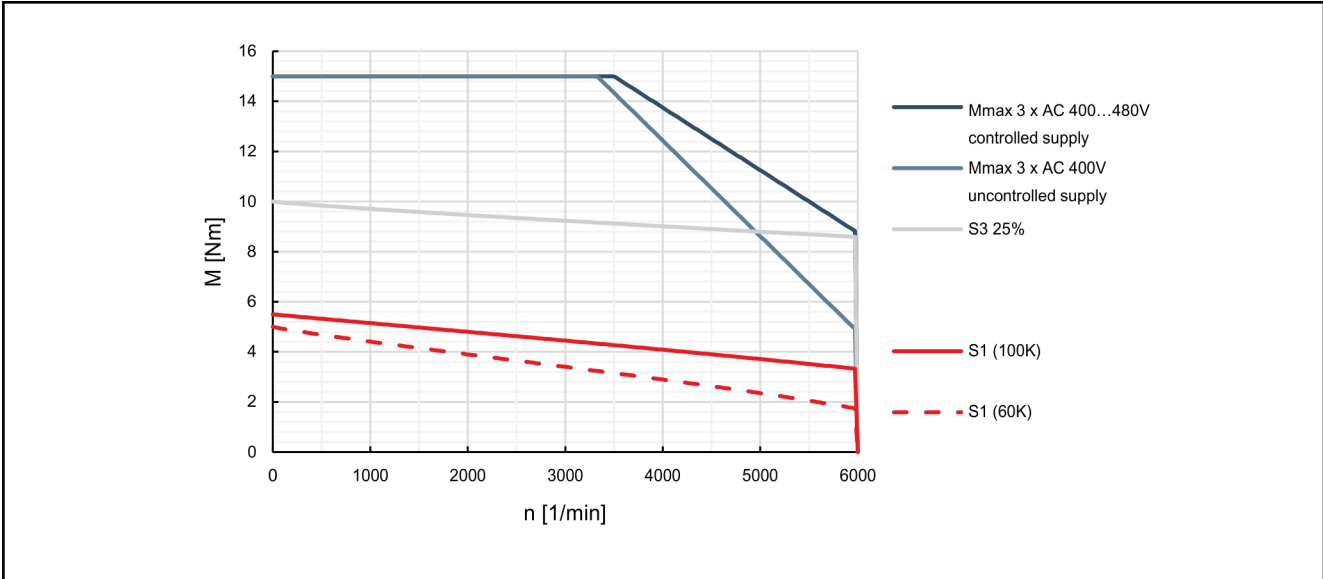

Fig. 4-17: Characteristic curves of motor MSK060B-0600

Technical data

4.13 MSK060C Technical data

Designation	Symbol	Unit	MSK060C-0300-NN	MSK060C-0600-NN
Continuous torque at standstill 60 K	$M_{0,60}$	Nm	8.0	
Continuous current at standstill 60 K	$I_{0,60(\text{eff})}$	A	4.8	9.5
Continuous torque at standstill 100 K	$M_{0,100}$	Nm	8.8	
Continuous current at standstill 100 K	$I_{0,100(\text{eff})}$	A	5.3	10.5
Continuous torque at standstill, surface	$M_{0,S}$	Nm	12.0	
Continuous current at standstill, surface	$I_{0,S(\text{eff})}$	A	7.2	14.3
Maximum torque	M_{max}	Nm	24.0	
Maximum current	$I_{\text{max}(\text{eff})}$	A	19.2	38.0
Torque constant at 20 °C	$K_{M,N}$	Nm/A	1.85	0.93
Voltage constant at 20 °C ¹⁾	$K_{EMK,1000}$	V/1000 min ⁻¹	114.0	57.0
Winding resistance at 20 °C	R_{12}	Ohm	3.1	0.8
Winding inductance	L_{12}	mH	35.9	8.6
Leakage capacitance of the component	C_{dis}	nF	2.1	2.2
Number of pole pairs	p	-	4	
Moment of inertia of rotor	J_{red}	kg*m ²	0.00080	
Thermal time constant	$T_{\text{th,nom}}$	min	14.0	
Maximum speed (electric)	$n_{\text{max el}}$	min ⁻¹	4900	6000
Sound pressure level	L_p	dB[A]	< 75	
Mass ²⁾	m	kg	8.4 (9.2)	
Ambient temperature during operation	T_{amb}	°C	0 ... 40	
Protection class (EN 60034-5)	-	-	IP65	
Thermal class (EN 60034-1)	T.CL.	-	155	

Last amended: 2014-01-21

- 1) Manufacturing tolerance ±5%
 2) (...) Motors with holding brake 1, 2, ...
 Tab. 4-12: Technical data

Technical data

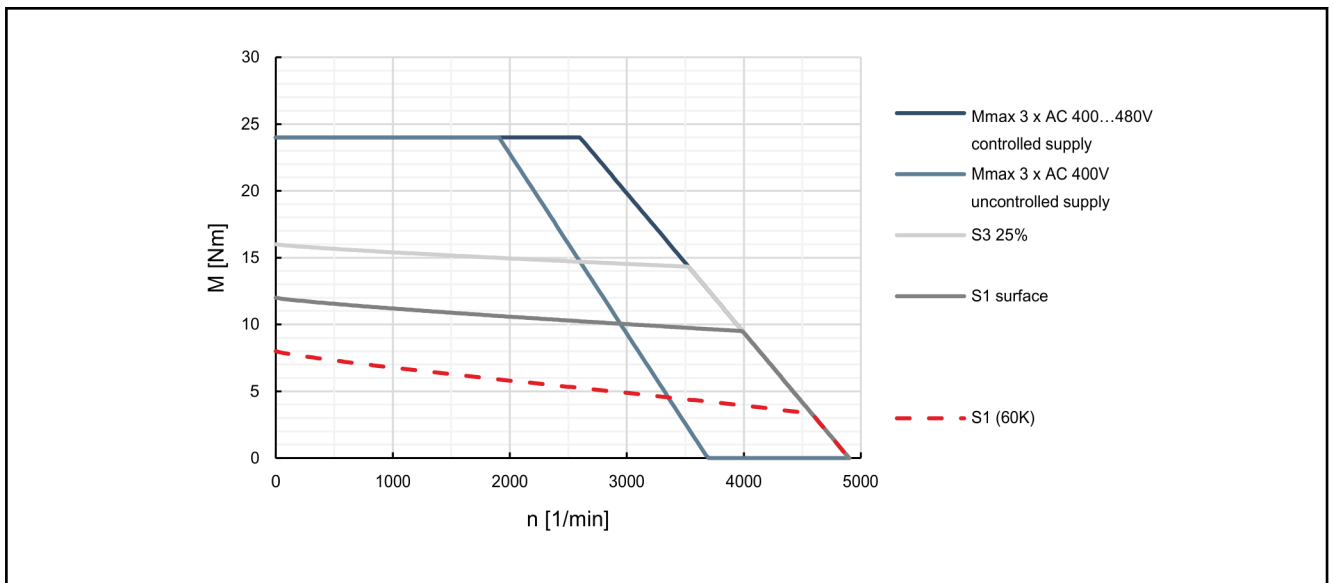

Fig. 4-18: Characteristic curves of motor MSK060C-0300

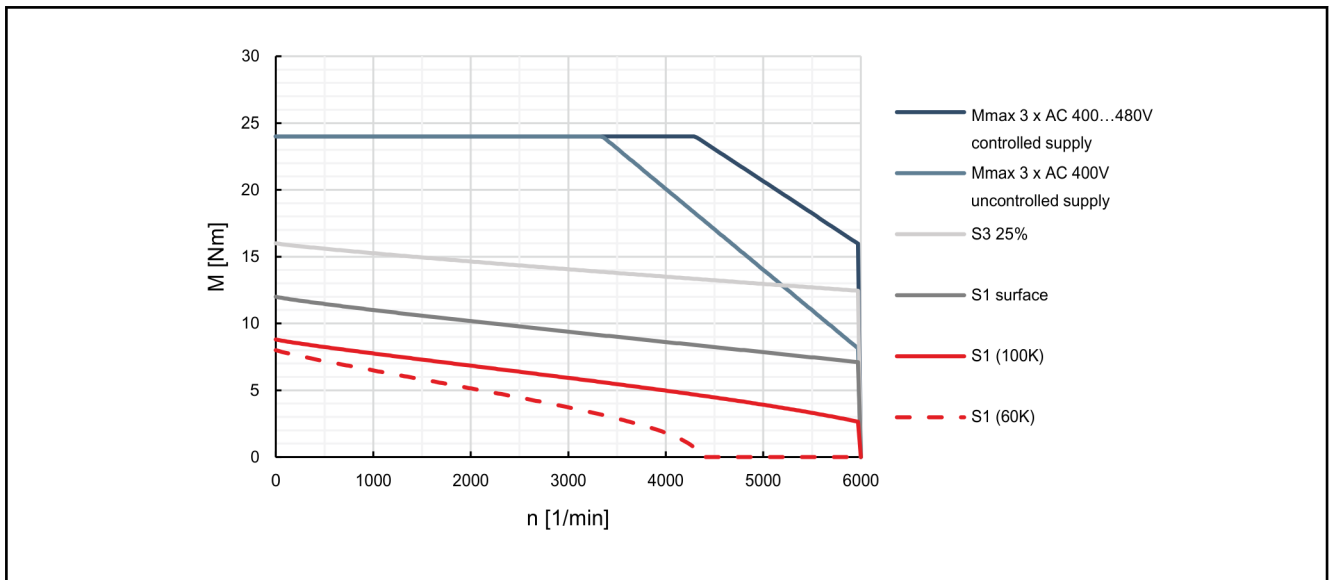

Fig. 4-19: Characteristic curves of motor MSK060C-0600

Technical data

4.14 MSK061B Technical data

Designation	Symbol	Unit	MSK061B-0300-NN
Continuous torque at standstill 60 K	M_{0_60}	Nm	3.5
Continuous current at standstill 60 K	$I_{0_60(\text{eff})}$	A	1.9
Continuous torque at standstill 100 K	M_{0_100}	Nm	3.9
Continuous current at standstill 100 K	$I_{0_100(\text{eff})}$	A	2.1
Maximum torque	M_{max}	Nm	14.0
Maximum current	$I_{\text{max}(\text{eff})}$	A	8.6
Torque constant at 20 °C	K_{M_N}	Nm/A	2.05
Voltage constant at 20 °C ¹⁾	$K_{\text{EMK_1000}}$	V/1000 min ⁻¹	126.4
Winding resistance at 20 °C	R_{12}	Ohm	13.5
Winding inductance	L_{12}	mH	44.0
Leakage capacitance of the component	C_{dis}	nF	1.8
Number of pole pairs	p	-	4
Moment of inertia of rotor	J_{red}	kg*m ²	0.00044
Thermal time constant	$T_{\text{th_nom}}$	min	15.0
Maximum speed (electric)	$n_{\text{max el}}$	min ⁻¹	4200
Sound pressure level	L_p	dB[A]	< 75
Mass ²⁾	m	kg	5.7 (6.4)
Ambient temperature during operation	T_{amb}	°C	0 ... 40
Protection class (EN 60034-5)	-	-	IP65
Thermal class (EN 60034-1)	T.CL.	-	155

Last amended: 2014-01-21

- 1) Manufacturing tolerance $\pm 5\%$
 2) (...) Motors with holding brake 1, 2, ...
 Tab. 4-13: MSK - Technical data

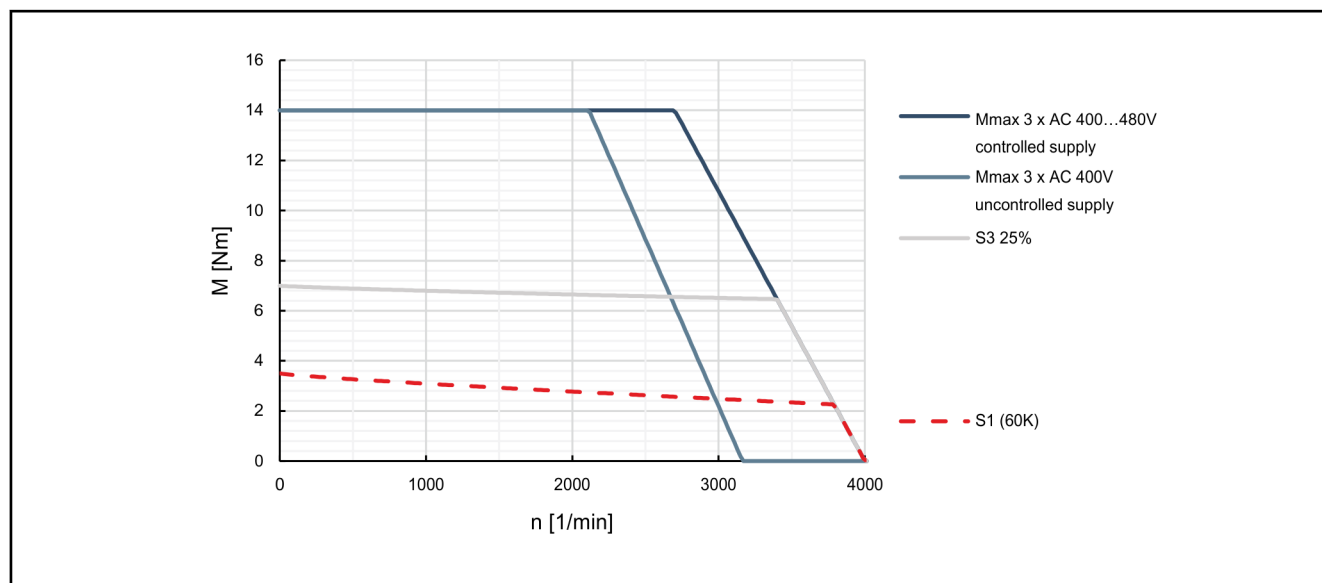

Fig. 4-20: Characteristic curves of motor MSK061B-0300

4.15 MSK061C Technical data

Designation	Symbol	Unit	MSK061C-0200-NN	MSK061C-0300-NN	MSK061C-0600-NN
Continuous torque at standstill 60 K	M_{0_60}	Nm	8.0		
Continuous current at standstill 60 K	$I_{0_60(\text{eff})}$	A	3.2	4.3	7.7
Continuous torque at standstill 100 K	M_{0_100}	Nm	9.0		
Continuous current at standstill 100 K	$I_{0_100(\text{eff})}$	A	3.6	4.8	8.7
Continuous torque at standstill, surface	M_{0_S}	Nm	12.0		
Continuous current at standstill, surface	$I_{0_S(\text{eff})}$	A	4.8	6.5	11.6
Maximum torque	M_{max}	Nm	32.0		
Maximum current	$I_{\text{max}(\text{eff})}$	A	14.4	19.4	34.7
Torque constant at 20 °C	K_{M_N}	Nm/A	2.80	2.04	1.14
Voltage constant at 20 °C ¹⁾	$K_{\text{EMK}_{1000}}$	V/1000 min ⁻¹	174.9	125.7	70.5
Winding resistance at 20 °C	R_{12}	Ohm	8.1	4.5	1.55
Winding inductance	L_{12}	mH	36.5	21.4	6.7
Leakage capacitance of the component	C_{dis}	nF	2.7	2.4	2.1
Number of pole pairs	p	-	4		
Moment of inertia of rotor	J_{red}	kg*m ²	0.00075		
Thermal time constant	$T_{\text{th_nom}}$	min	18.0		15.0
Maximum speed (electric)	$n_{\text{max el}}$	min ⁻¹	3,100	4200	6000
Sound pressure level	L_p	dB[A]	< 75		
Mass ²⁾	m	kg	8.3 (8.8)		
Ambient temperature during operation	T_{amb}	°C	0 ... 40		
Protection class (EN 60034-5)	-	-	IP65		
Thermal class (EN 60034-1)	T.CL.	-	155		

Last amended: 2014-01-21

- 1) Manufacturing tolerance ±5%
 2) (...) Motors with holding brake 1, 2, ...
 Tab. 4-14: MSK - Technical data

Technical data

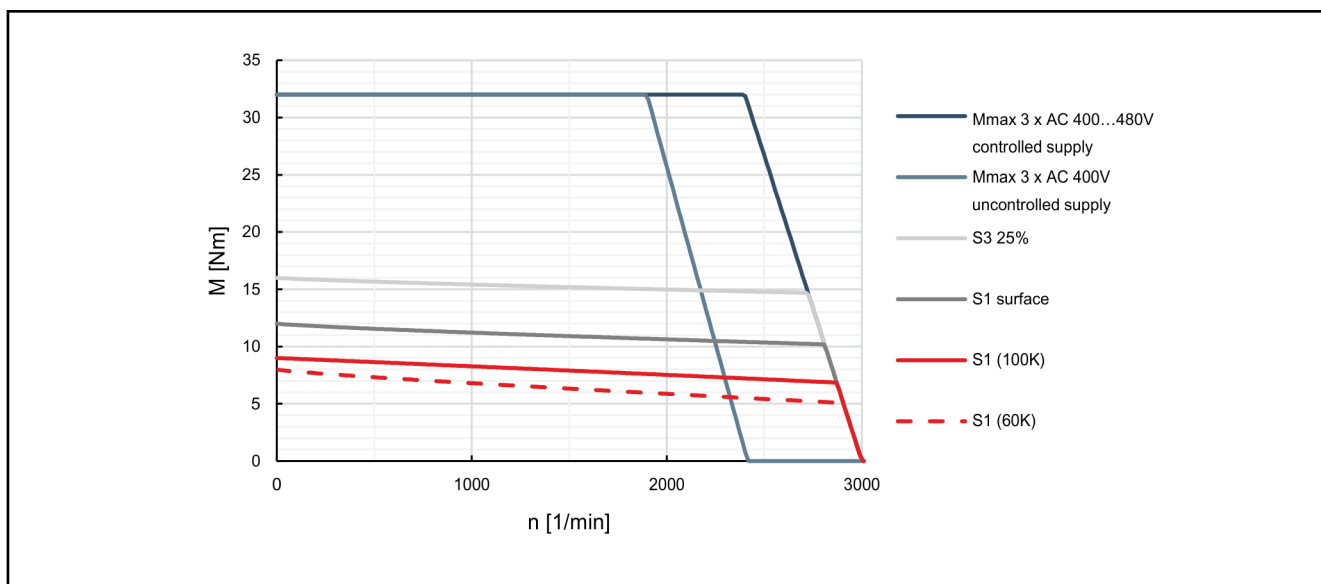

Fig. 4-21: Characteristic curves of motor MSK061C-0200

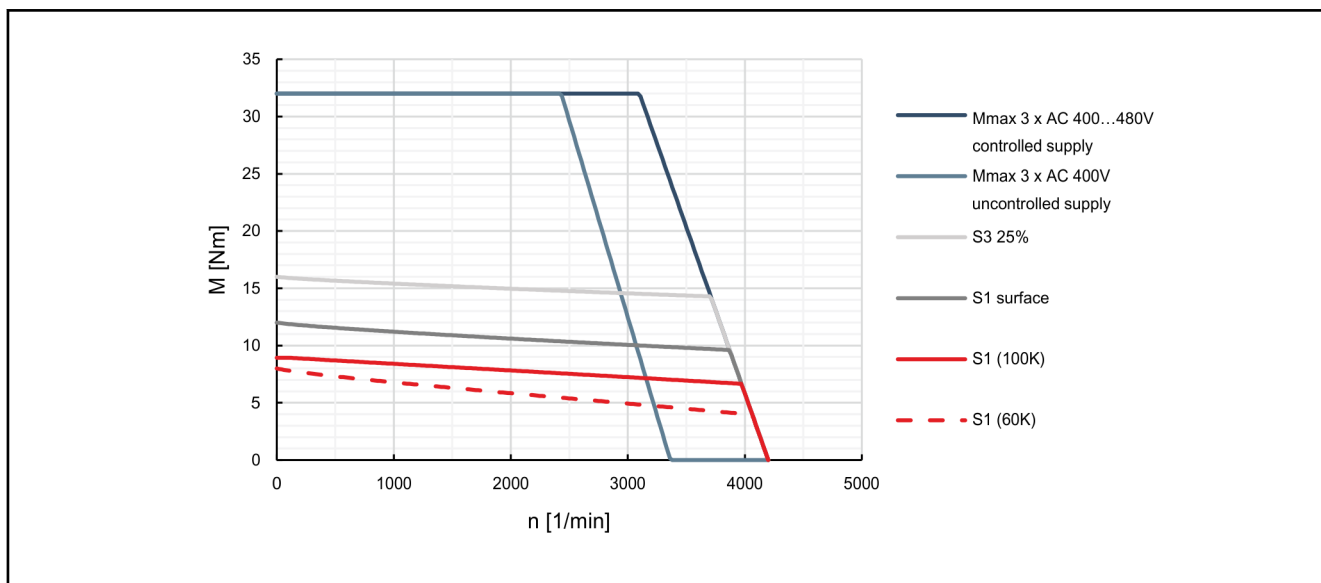

Fig. 4-22: Characteristic curves of motor MSK061C-0300

Technical data

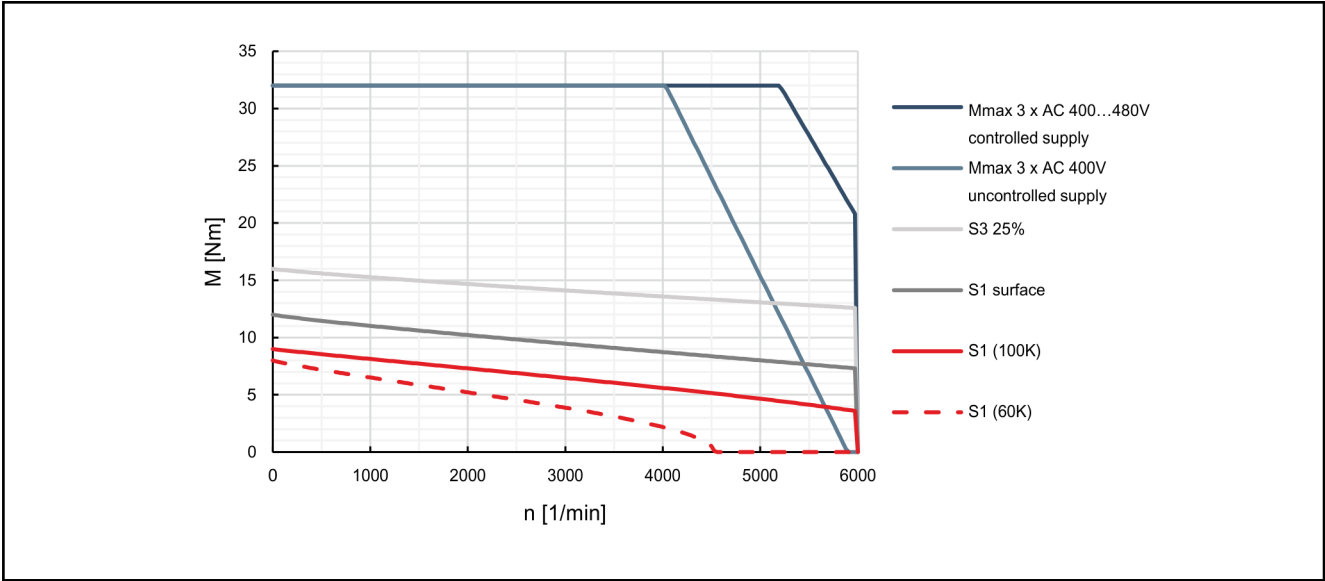

Fig. 4-23: Characteristic curves of motor MSK061C-0600

Technical data

4.16 MSK070C Technical data

Designation	Symbol	Unit	MSK070C-0150-NN	MSK070C-0300-NN	MSK070C-0450-NN
Continuous torque at standstill 60 K	$M_{0,60}$	Nm	13.0		
Continuous current at standstill 60 K	$I_{0,60(\text{eff})}$	A	4.1	8.2	12.3
Continuous torque at standstill 100 K	$M_{0,100}$	Nm	14.5		
Continuous current at standstill 100 K	$I_{0,100(\text{eff})}$	A	4.6	9.2	13.7
Continuous torque at standstill, surface	$M_{0,S}$	Nm	19.5		
Continuous current at standstill, surface	$I_{0,S(\text{eff})}$	A	6.2	12.3	18.5
Maximum torque	M_{max}	Nm	33.0		
Maximum current	$I_{\text{max}(\text{eff})}$	A	12.6	25.0	36.9
Torque constant at 20 °C	$K_{M,N}$	Nm/A	3.47	1.74	1.16
Voltage constant at 20 °C ¹⁾	$K_{\text{EMK},1000}$	V/1000 min ⁻¹	213.2	107.0	71.3
Winding resistance at 20 °C	R_{12}	Ohm	4.7	1.13	0.55
Winding inductance	L_{12}	mH	34.9	8.3	4.0
Leakage capacitance of the component	C_{dis}	nF	3.8	4.0	3.1
Number of pole pairs	p	-	6		
Moment of inertia of rotor	J_{red}	kg*m ²	0.00291		
Thermal time constant	$T_{\text{th,nom}}$	min	22.0		31.0
Maximum speed (electric)	$n_{\text{max el}}$	min ⁻¹	2,500	5,500	6000
Sound pressure level	L_p	dB[A]	< 75		
Mass ²⁾	m	kg	11.7 (13.2)		
Ambient temperature during operation	T_{amb}	°C	0 ... 40		
Protection class (EN 60034-5)	-	-	IP65		
Thermal class (EN 60034-1)	T.CL.	-	155		

Last amended: 2014-01-21

- 1) Manufacturing tolerance ±5%
 2) (...) Motors with holding brake 1, 2, ...
 Tab. 4-15: MSK - Technical data

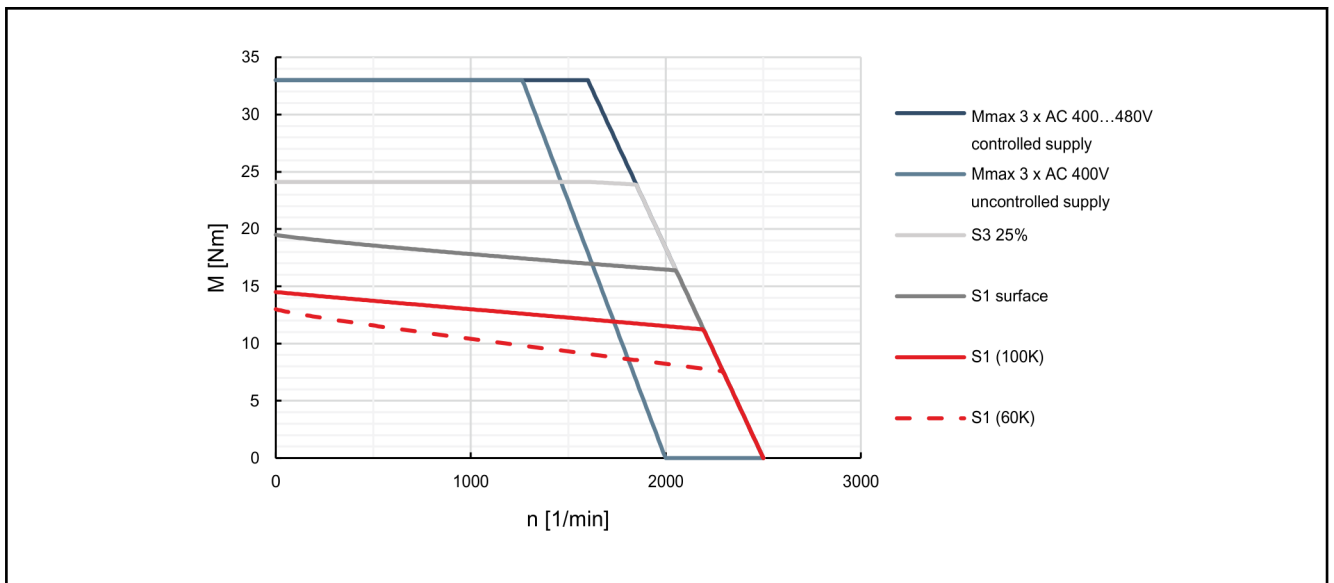

Fig. 4-24: Characteristic curves of motor MSK070C-0150

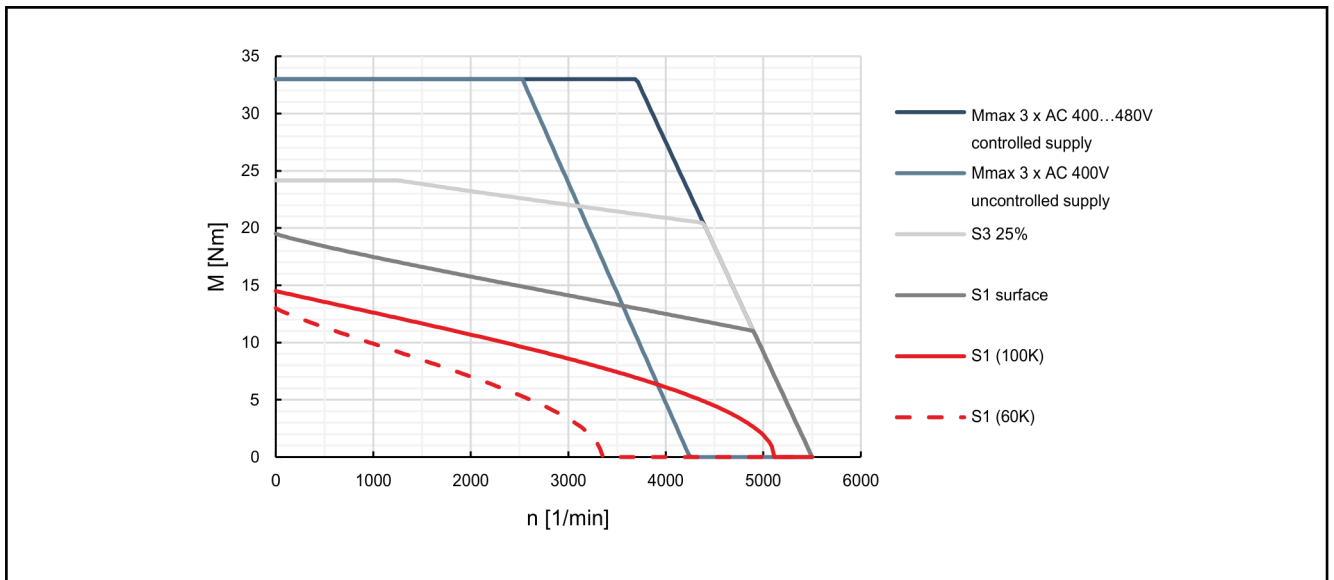

Fig. 4-25: Characteristic curves of motor MSK070C-0300

Technical data

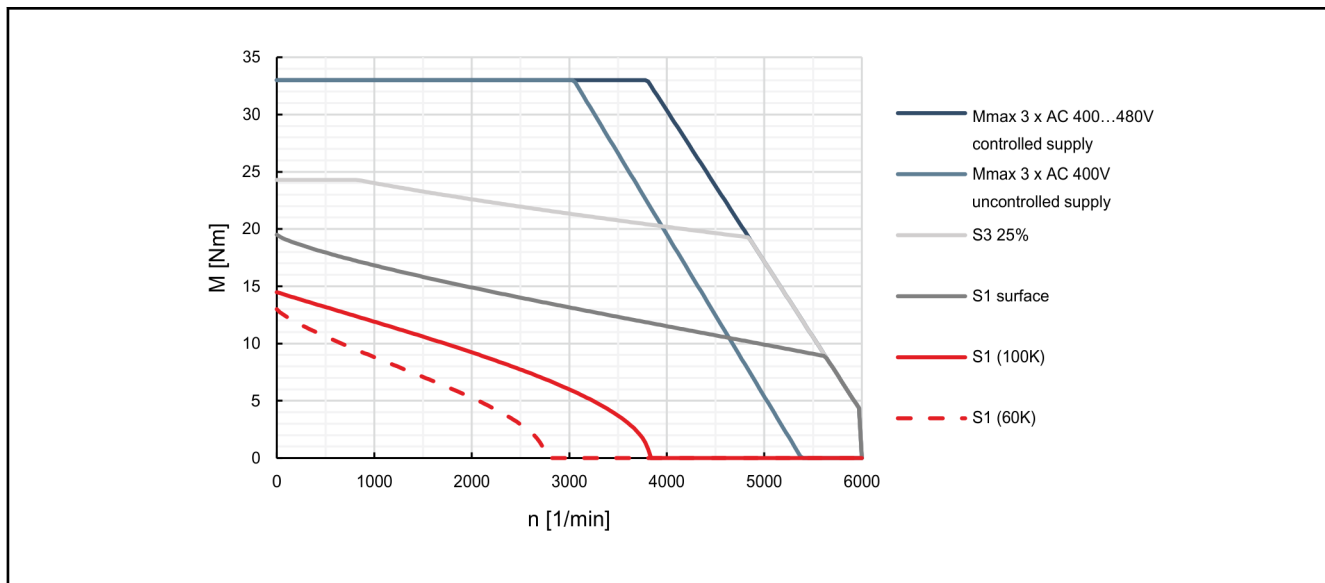

Fig. 4-26: Characteristic curves of motor MSK070C-0450

4.17 MSK070D Technical data

Designation	Symbol	Unit	MSK070D-0150-NN	MSK070D-0300-NN	MSK070D-0450-NN
Continuous torque at standstill 60 K	M_{0_60}	Nm	17.5		
Continuous current at standstill 60 K	$I_{0_60(\text{eff})}$	A	6.2	11.0	16.6
Continuous torque at standstill 100 K	M_{0_100}	Nm	20.0		
Continuous current at standstill 100 K	$I_{0_100(\text{eff})}$	A	7.1	12.6	22.0
Continuous torque at standstill, surface	M_{0_S}	Nm	26.3		
Continuous current at standstill, surface	$I_{0_S(\text{eff})}$	A	9.3	16.5	24.9
Maximum torque	M_{max}	Nm	52.5		
Maximum current	$I_{\text{max}(\text{eff})}$	A	24.8	33.0	49.8
Torque constant at 20 °C	K_{M_N}	Nm/A	3.10	1.75	1.16
Voltage constant at 20 °C ¹⁾	K_{EMK_1000}	V/1000 min ⁻¹	210.0	107.3	71.1
Winding resistance at 20 °C	R_{12}	Ohm	3.2	0.75	0.37
Winding inductance	L_{12}	mH	25.9	6.0	3.0
Leakage capacitance of the component	C_{dis}	nF	5.0	4.5	
Number of pole pairs	p	-	6		
Moment of inertia of rotor	J_{red}	kg*m ²	0.00375		
Thermal time constant	$T_{\text{th_nom}}$	min	23.0		
Maximum speed (electric)	$n_{\text{max el}}$	min ⁻¹	2,700	4900	6000
Sound pressure level	L_p	dB[A]	< 75		
Mass ²⁾	m	kg	14.0 (15.6)		
Ambient temperature during operation	T_{amb}	°C	0 ... 40		
Protection class (EN 60034-5)	-	-	IP65		
Thermal class (EN 60034-1)	T.CL.	-	155		

Last amended: 2014-01-21

- 1) Manufacturing tolerance ±5%
 2) (...) Motors with holding brake 1, 2, ...
 Tab. 4-16: MSK - Technical data

Technical data

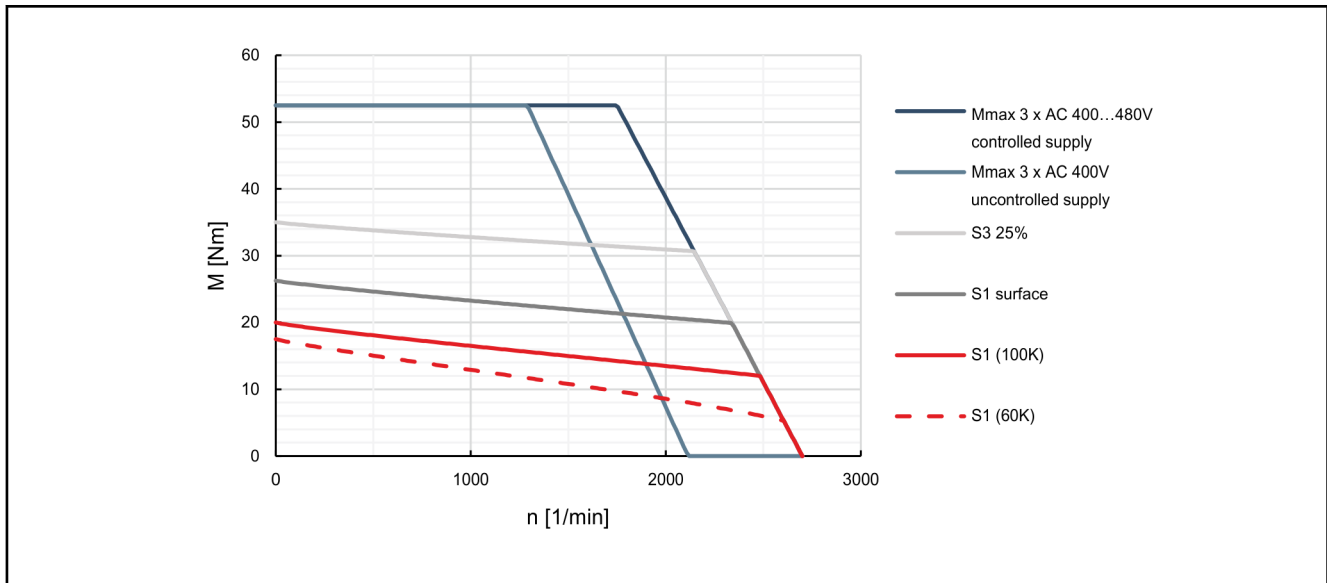

Fig. 4-27: Characteristic curves of motor MSK070D-0150

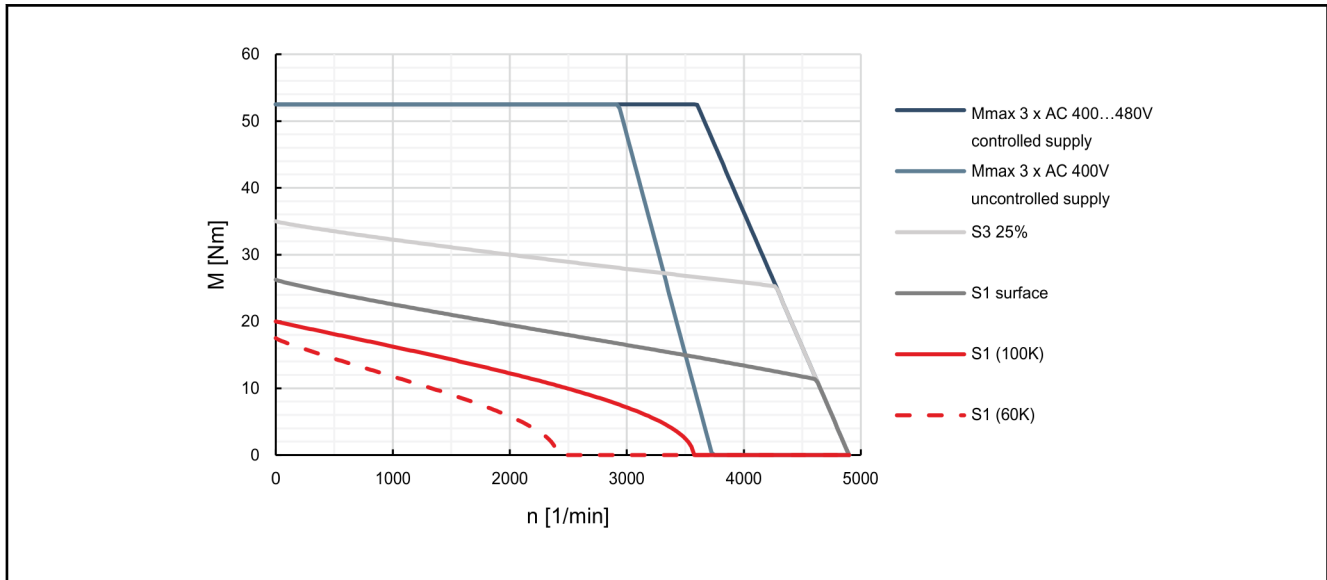

Fig. 4-28: Characteristic curves of motor MSK070D-0300

Technical data

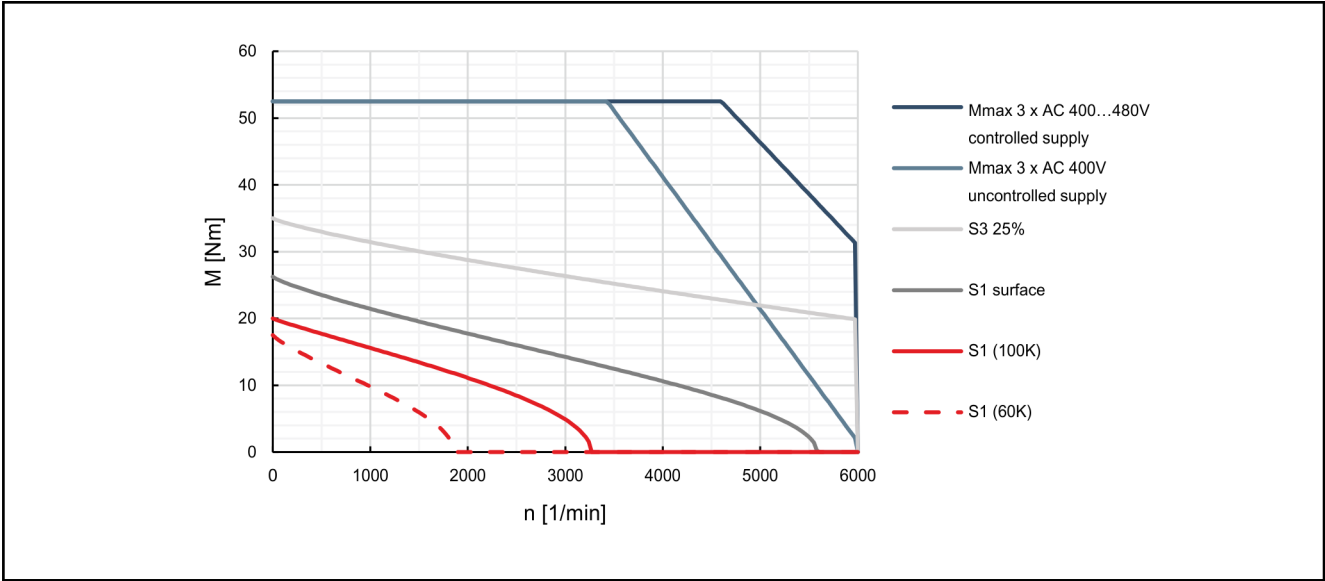

Fig. 4-29: Characteristic curves of motor MSK070D-0450

Technical data

4.18 MSK070E Technical data

Designation	Symbol	Unit	MSK070E-0150-NN	MSK070E-0300-NN	MSK070E-0450-NN
Continuous torque at standstill 60 K	$M_{0,60}$	Nm	23.0		
Continuous current at standstill 60 K	$I_{0,60(\text{eff})}$	A	6.4	15.4	19.3
Continuous torque at standstill 100 K	$M_{0,100}$	Nm	25.0		
Continuous current at standstill 100 K	$I_{0,100(\text{eff})}$	A	7.0	16.7	21.0
Continuous torque at standstill, surface	$M_{0,S}$	Nm	34.5		
Continuous current at standstill, surface	$I_{0,S(\text{eff})}$	A	9.6	23.1	29.0
Maximum torque	M_{max}	Nm	70.0	65.0	60.0
Maximum current	$I_{\text{max}(\text{eff})}$	A	25.6	49.3	57.9
Torque constant at 20 °C	$K_{M,N}$	Nm/A	3.94	1.64	1.31
Voltage constant at 20 °C ¹⁾	$K_{\text{EMK},1000}$	V/1000 min ⁻¹	242.4	101.0	80.6
Winding resistance at 20 °C	R_{12}	Ohm	3.1	0.53	0.36
Winding inductance	L_{12}	mH	24.5	3.9	2.7
Leakage capacitance of the component	C_{dis}	nF	6.3	3.5	6.7
Number of pole pairs	p	-	6		
Moment of inertia of rotor	J_{red}	kg*m ²	0.00458		
Thermal time constant	$T_{\text{th,nom}}$	min	32.0		
Maximum speed (electric)	$n_{\text{max el}}$	min ⁻¹	2200	5300	6000
Sound pressure level	L_p	dB[A]	< 75		
Mass ²⁾	m	kg	16.2 (17.8)		
Ambient temperature during operation	T_{amb}	°C	0 ... 40		
Protection class (EN 60034-5)	-	-	IP65		
Thermal class (EN 60034-1)	T.CL.	-	155		

Last amended: 2014-01-21

- 1) Manufacturing tolerance ±5%
 2) (...) Motors with holding brake 1, 2, ...
 Tab. 4-17: MSK - Technical data

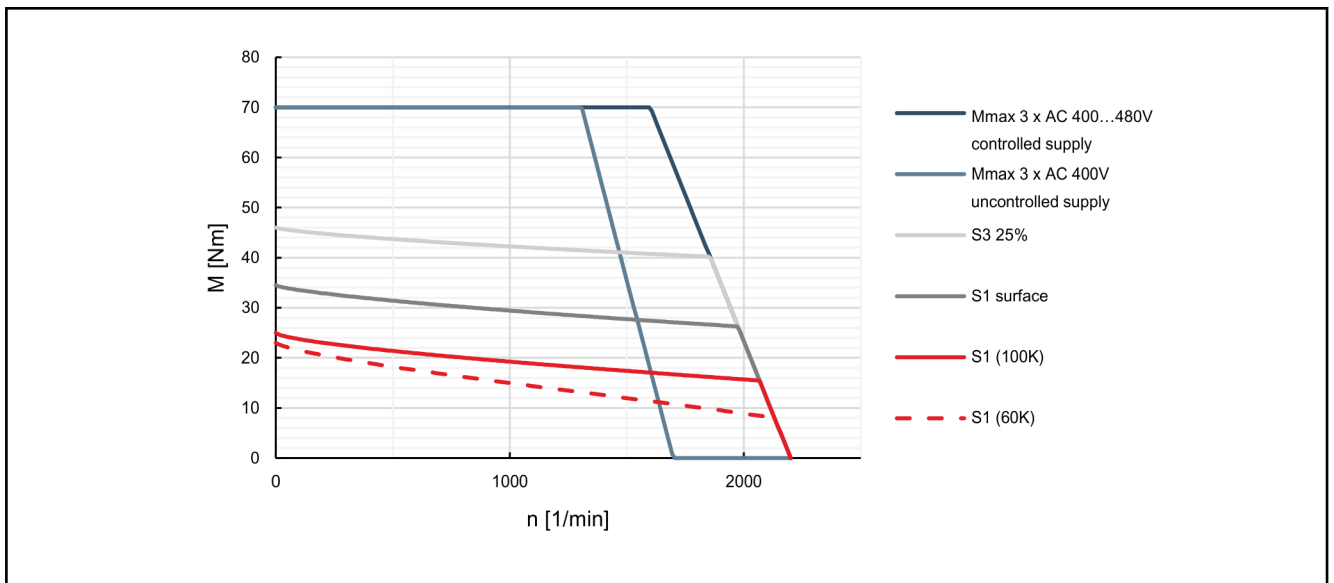

Fig. 4-30: Characteristic curves of motor MSK070E-0150

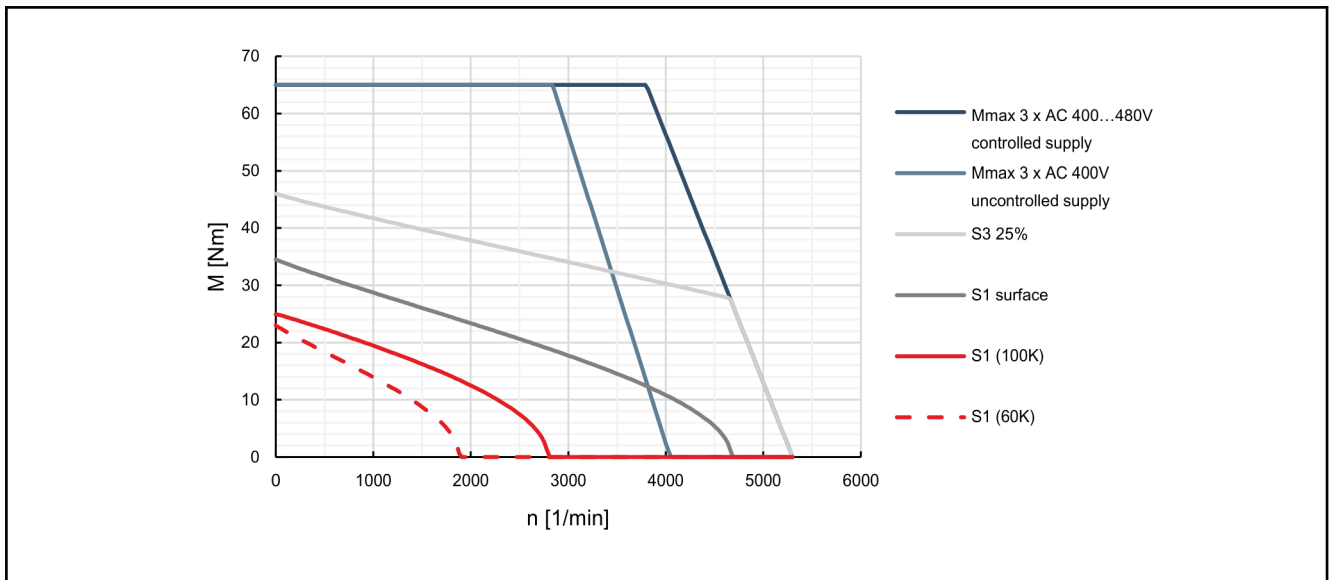

Fig. 4-31: Characteristic curves of motor MSK070E-0300

Technical data

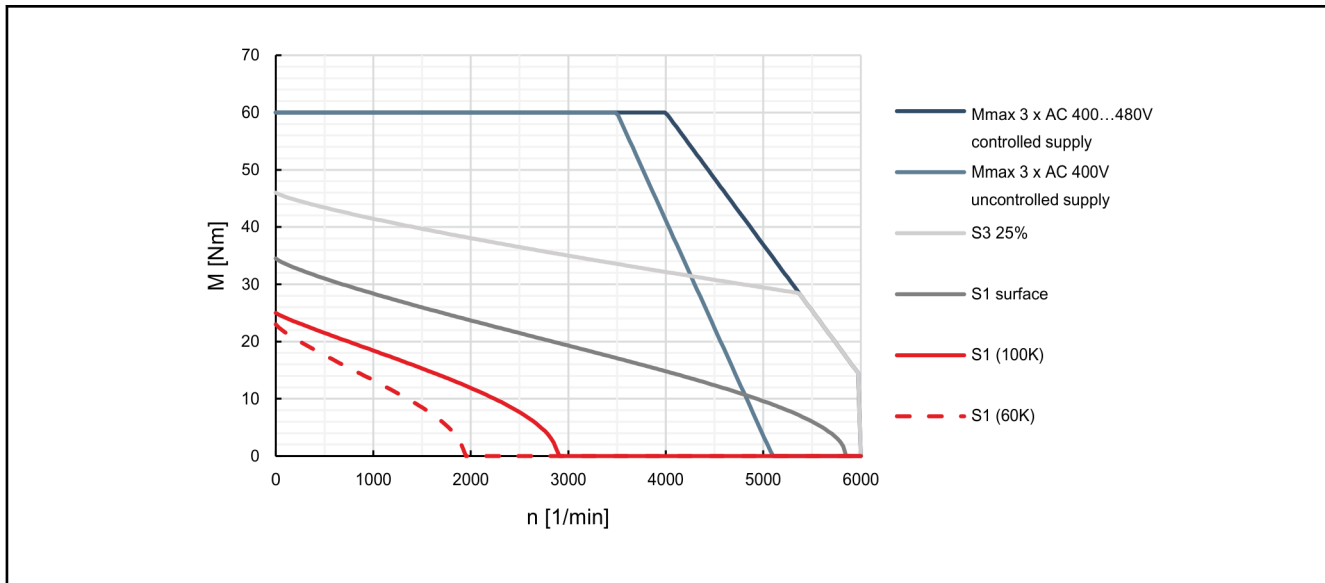

Fig. 4-32: Characteristic curves of motor MSK070E-0450

4.19 MSK071C Technical data

Designation	Symbol	Unit	MSK071C -0200-FN	MSK071C -0200-NN	MSK071C -0300-FN	MSK071C -0300-NN	MSK071C -0450-FN	MSK071C -0450-NN
Continuous torque at standstill 60 K	$M_{0,60}$	Nm	12.0					
Continuous current at standstill 60 K	$I_{0,60(\text{eff})}$	A	5.2		7.3		8.9	
Continuous torque at standstill 100 K	$M_{0,100}$	Nm	14.0					
Continuous current at standstill 100 K	$I_{0,100(\text{eff})}$	A	6.1		8.5		10.4	
Continuous torque at standstill, surface	$M_{0,S}$	Nm	---	18.0	---	18.0	---	18.0
Continuous current at standstill, surface	$I_{0,S(\text{eff})}$	A	---	7.8	---	11.0	---	13.4
Continuous torque at standstill, liquid	$M_{0,L}$	Nm	22.8	---	22.8	---	22.8	---
Continuous current at standstill, liquid	$I_{0,L(\text{eff})}$	A	9.9	---	13.9	---	16.9	---
Maximum torque	M_{max}	Nm	44.0					
Maximum current	$I_{\text{max}(\text{eff})}$	A	23.4		32.9		40.1	
Torque constant at 20 °C	$K_{M,N}$	Nm/A	2.50		1.80		1.49	
Voltage constant at 20 °C ¹⁾	$K_{\text{EMK},1000}$	V/1000 min ⁻¹	155.5		110.5		91.3	
Winding resistance at 20 °C	R_{12}	Ohm	3.1		1.68		1.1	
Winding inductance	L_{12}	mH	19.5		10.9		6.7	
Leakage capacitance of the component	C_{dis}	nF	4.6				4.2	
Number of pole pairs	p	-	4					
Moment of inertia of rotor	J_{red}	kg*m ²	0.00173					
Thermal time constant	$T_{\text{th,nom}}$	min	3.0	28.0	3.0	28.0	3.0	28.0
Maximum speed	n_{max}	min ⁻¹	3500		5000		5800	
Sound pressure level	L_P	dB[A]	< 75					
Mass ²⁾	m	kg	13.9 (15.8)					
Ambient temperature during operation	T_{amb}	°C	0 ... 40					
Protection class (EN 60034-5)	-	-	IP65					
Thermal class (EN 60034-1)	T.CL.	-	155					
Data liquid cooling								
Heat loss to be dissipated	P_V	kW	0.75	---	0.75	---	0.75	---
Inlet temperature coolant	T_{in}	°C	10 ... 40	---	10 ... 40	---	10 ... 40	---
Permissible coolant temperature increase at P_V	ΔT_{max}	K	10	---	10	---	10	---
Required coolant flow rate at P_V	Q_{min}	l/min	1.1	---	1.1	---	1.1	---
Pressure drop at Q_{min}	Δp	bar	0.3	---	0.3	---	0.3	---
Maximum permissible inlet pressure	p_{max}	bar	6.0	---	6.0	---	6.0	---
Volume of coolant duct	V_{cool}	l	0.04	---	0.04	---	0.04	---
Material of coolant duct			Die-cast aluminum					

Last amended: 2014-01-21

1) Manufacturing tolerance ±5%
 2) (...) Motors with holding brake 1, 2, ...
 Tab. 4-18: MSK - Technical data

Technical data

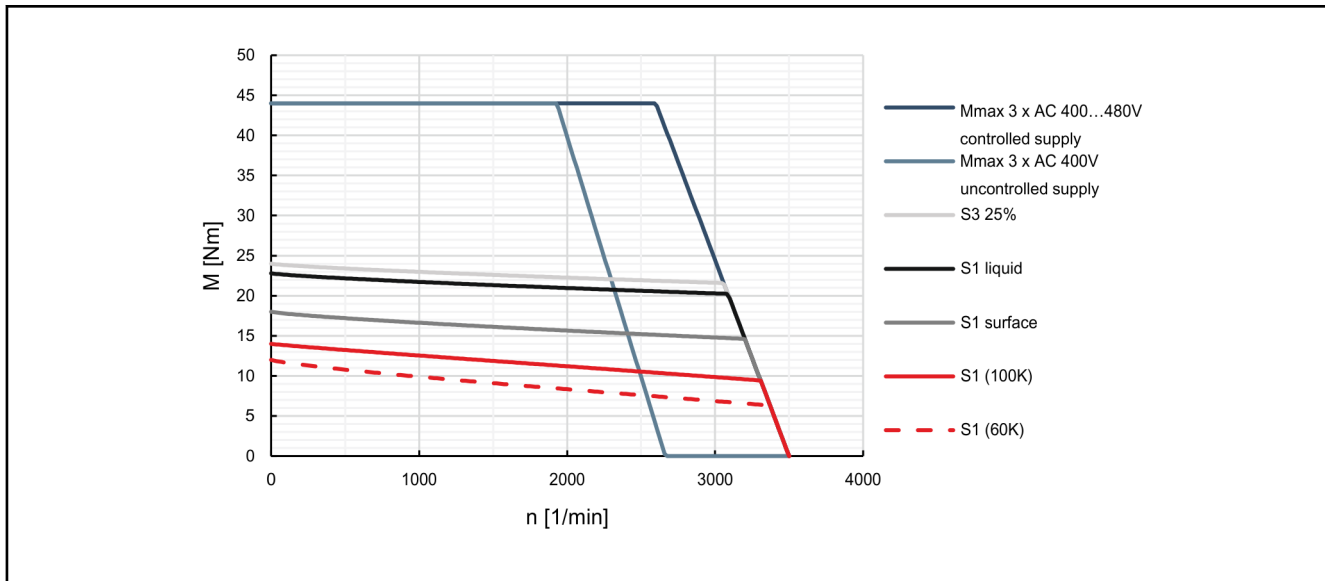

Fig. 4-33: Characteristic curves of motor MSK071C-0200

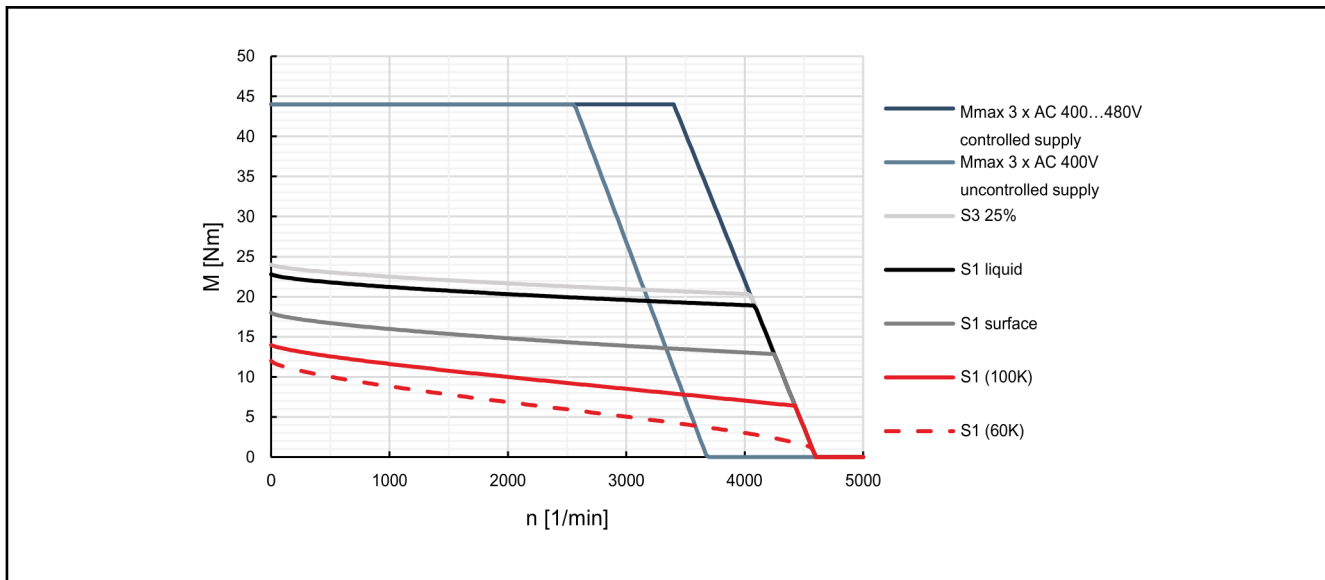

Fig. 4-34: Characteristic curves of motor MSK071C-0300

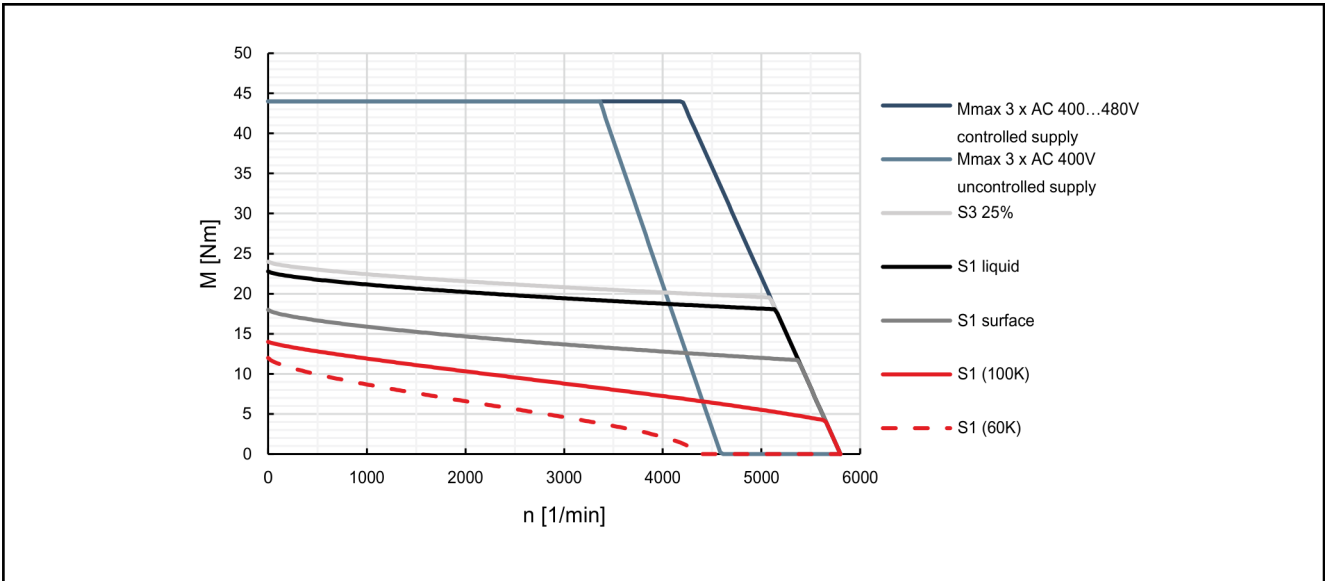

Fig. 4-35: Characteristic curves of motor MSK071C-0450

Technical data

4.20 MSK071D Technical data

Designation	Symbol	Unit	MSK071D -0200-FN	MSK071D -0200-NN	MSK071D -0300-FN	MSK071D -0300-NN	MSK071D -0450-FN	MSK071D -0450-NN
Continuous torque at standstill 60 K ³⁾	$M_{0,60}$	Nm	17.5					
Continuous current at standstill 60 K	$I_{0,60(\text{eff})}$	A	7.3		9.1		15.4	
Continuous torque at standstill 100 K ³⁾	$M_{0,100}$	Nm	20.0					
Continuous current at standstill 100 K	$I_{0,100(\text{eff})}$	A	8.6		10.7		17.6	
Continuous torque at standstill, surface ³⁾	$M_{0,S}$	Nm	---	26.3	---	26.3	---	26.3
Continuous current at standstill, surface	$I_{0,S(\text{eff})}$	A	---	11.0	---	13.5	---	23.1
Continuous torque at standstill, liquid ³⁾	$M_{0,L}$	Nm	33.3	---	33.3	---	33.3	---
Continuous current at standstill, liquid	$I_{0,L(\text{eff})}$	A	13.9	---	17.2	---	30.3	---
Maximum torque	M_{max}	Nm	66.0					
Maximum current	$I_{\text{max}(\text{eff})}$	A	32.8		40.5		69.3	
Torque constant at 20 °C	$K_{M,N}$	Nm/A	2.63		2.12		1.25	
Voltage constant at 20 °C ¹⁾	$K_{\text{EMK},1000}$	V/1000 min ⁻¹	162.0		134.0		77.1	
Winding resistance at 20 °C	R_{12}	Ohm	1.9		1.26		0.45	
Winding inductance	L_{12}	mH	14.2		10.7		3.2	
Leakage capacitance of the component	C_{dis}	nF	6.9		7.2		7.8	
Number of pole pairs	p	-	4					
Moment of inertia of rotor	J_{red}	kg*m ²	0.00230					
Thermal time constant	$T_{\text{th,nom}}$	min	6.0	54.0	6.0	54.0	6.0	52.0
Maximum speed	n_{max}	min ⁻¹	3,200		3800		6000	
Sound pressure level	L_p	dB[A]	< 75					
Mass ²⁾	m	kg	18.0 (19.6)					
Ambient temperature during operation	T_{amb}	°C	0 ... 40					
Protection class (EN 60034-5)	-	-	IP65					
Thermal class (EN 60034-1)	T.CL.	-	155					
Data liquid cooling								
Heat loss to be dissipated	P_V	kW	0.90	---	0.90	---	0.90	---
Inlet temperature coolant	T_{in}	°C	10 ... 40		10 ... 40		10 ... 40	
Permissible coolant temperature increase at P_V	ΔT_{max}	K	10	---	10	---	10	---
Required coolant flow rate at P_V	Q_{min}	l/min	1.3	---	1.3	---	1.3	---
Pressure drop at Q_{min}	Δp	bar	0.4	---	0.4	---	0.4	---
Maximum permissible inlet pressure	p_{max}	bar	6.0	---	6.0	---	6.0	---
Volume of coolant duct	V_{cool}	l	0.05	---	0.05	---	0.05	---
Material of coolant duct			Die-cast aluminum					

Last amended: 2014-01-21

- 1) Manufacturing tolerance $\pm 5\%$
2) (...) Motors with holding brake 1, 2, ...

3) Information applicable for rotating motor ($f_{ei} \geq 0.4$ Hz). At $n = 0$ min^{-1} , reduction to 95% with convection cooling, 80% with forced cooling, 75% with liquid cooling

Tab. 4-19: MSK - Technical data

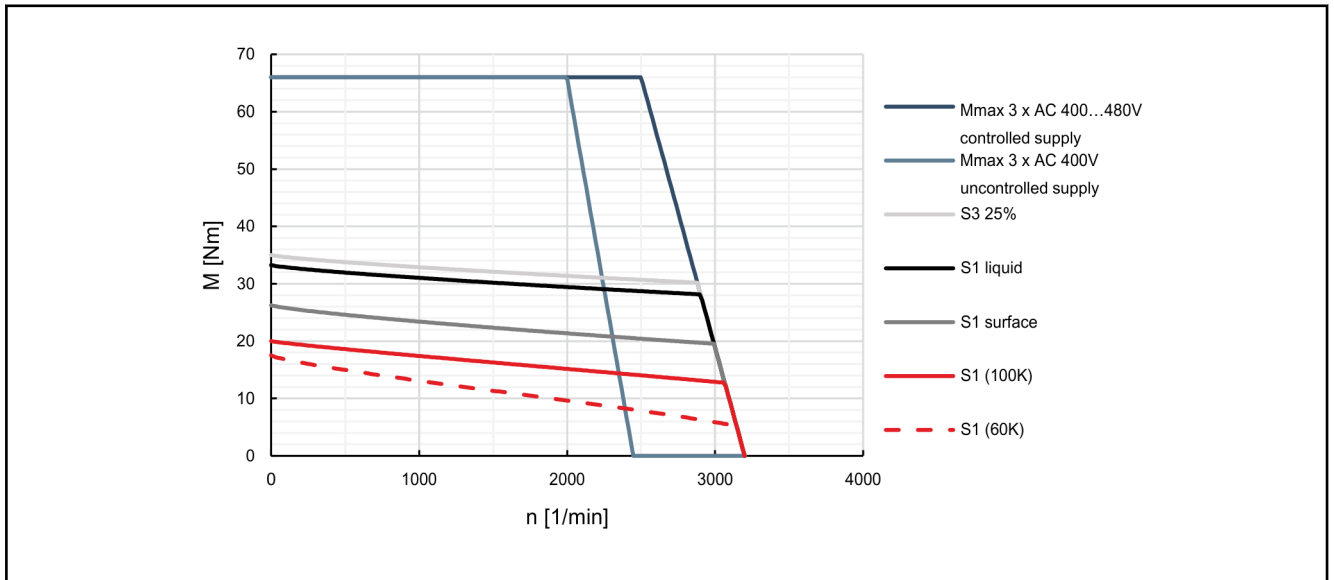

Fig. 4-36: Characteristic curves of motor MSK071D-0200

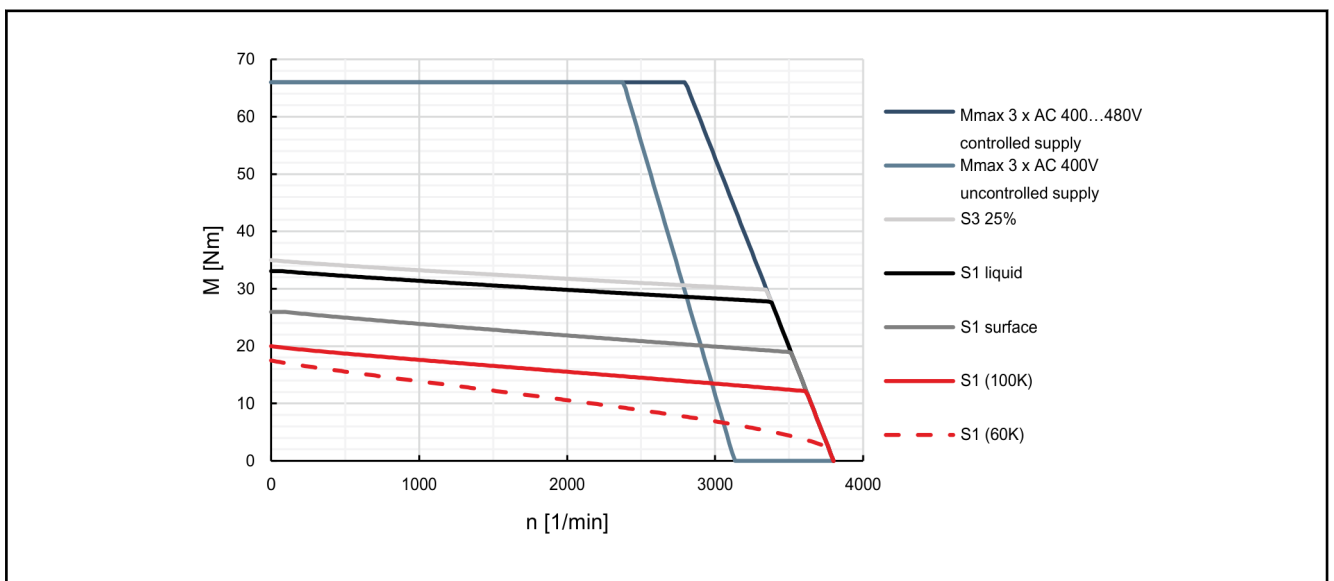

Fig. 4-37: Characteristic curves of motor MSK071D-0300

Technical data

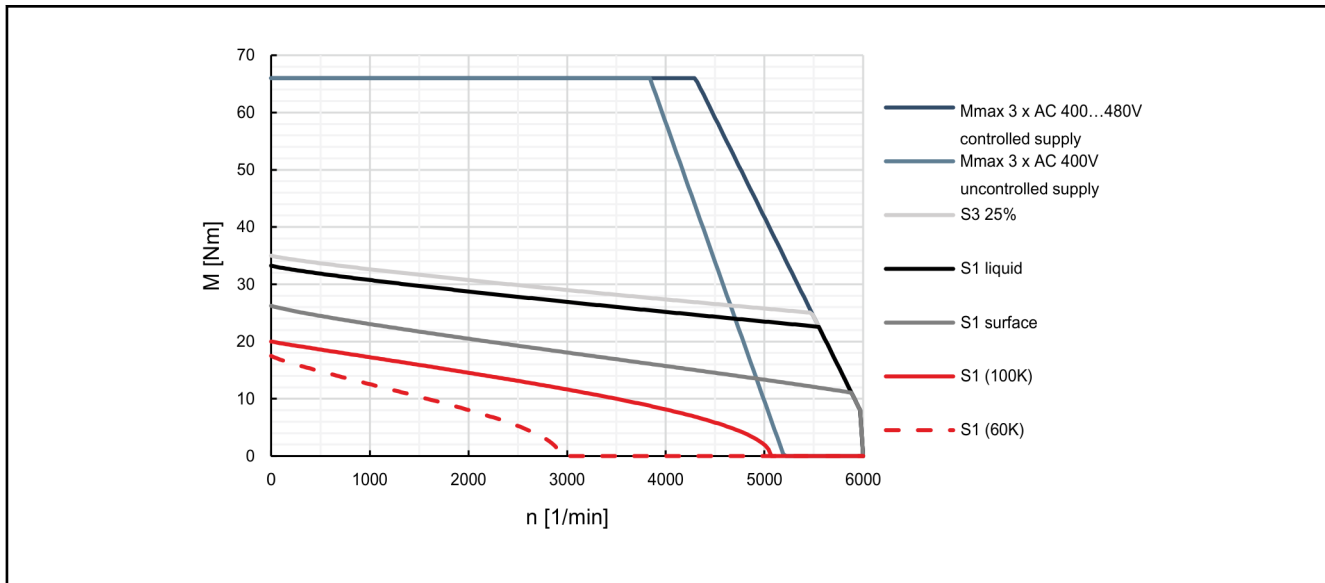

Fig. 4-38: Characteristic curves of motor MSK071D-0450

4.21 MSK071E Technical data

Designation	Symbol	Unit	MSK071E -0200-FN	MSK071E -0200-NN	MSK071E -0300-FN	MSK071E -0300-NN	MSK071E -0450-FN	MSK071E -0450-NN
Continuous torque at standstill 60 K	$M_{0,60}$	Nm	23.0					
Continuous current at standstill 60 K	$I_{0,60(\text{eff})}$	A	10.1		12.5		20.0	
Continuous torque at standstill 100 K	$M_{0,100}$	Nm	28.0					
Continuous current at standstill 100 K	$I_{0,100(\text{eff})}$	A	12.6		15.2		24.4	
Continuous torque at standstill, surface	$M_{0,S}$	Nm	---	34.5	---	34.5	---	34.5
Continuous current at standstill, surface	$I_{0,S(\text{eff})}$	A	---	15.2	---	18.8	---	30.0
Continuous torque at standstill, liquid	$M_{0,L}$	Nm	43.7	---	43.7	---	43.7	---
Continuous current at standstill, liquid	$I_{0,L(\text{eff})}$	A	19.0	---	24.9	---	38.0	---
Maximum torque	M_{max}	Nm	84.0					
Maximum current	$I_{\text{max}(\text{eff})}$	A	45.5		56.3		90.1	
Torque constant at 20 °C	$K_{M,N}$	Nm/A	2.51		2.05		1.29	
Voltage constant at 20 °C ¹⁾	$K_{EMK,1000}$	V/1000 min ⁻¹	154.6		126.4		82.7	
Winding resistance at 20 °C	R_{12}	Ohm	1.16		0.79		0.32	
Winding inductance	L_{12}	mH	9.15		5.9		2.6	
Leakage capacitance of the component	C_{dis}	nF	8.9		9.3		9.5	
Number of pole pairs	p	-	4					
Moment of inertia of rotor	J_{red}	kg*m ²	0.00290					
Thermal time constant	$T_{\text{th,nom}}$	min	8.0	55.0	8.0	55.0	8.0	55.0
Maximum speed	n_{max}	min ⁻¹	3400		4200		6000	
Sound pressure level	L_P	dB[A]	< 75					
Mass ²⁾	m	kg	23.5 (25.1)					
Ambient temperature during operation	T_{amb}	°C	0 ... 40					
Protection class (EN 60034-5)	-	-	IP65					
Thermal class (EN 60034-1)	T.CL.	-	155					
Data liquid cooling								
Heat loss to be dissipated	P_V	kW	1.00	---	1.00	---	1.00	---
Inlet temperature coolant	T_{in}	°C	10 ... 40	---	10 ... 40	---	10 ... 40	---
Permissible coolant temperature increase at P_V	ΔT_{max}	K	10	---	10	---	10	---
Required coolant flow rate at P_V	Q_{min}	l/min	1.5	---	1.5	---	1.5	---
Pressure drop at Q_{min}	Δp	bar	0.5	---	0.5	---	0.5	---
Maximum permissible inlet pressure	p_{max}	bar	6.0	---	6.0	---	6.0	---
Volume of coolant duct	V_{cool}	l	0.06	---	0.06	---	0.06	---
Material of coolant duct			Die-cast aluminum					

Last amended: 2014-01-21

- 1) Manufacturing tolerance ±5%
 2) (...) Motors with holding brake 1, 2, ...
 Tab. 4-20: MSK - Technical data

Technical data

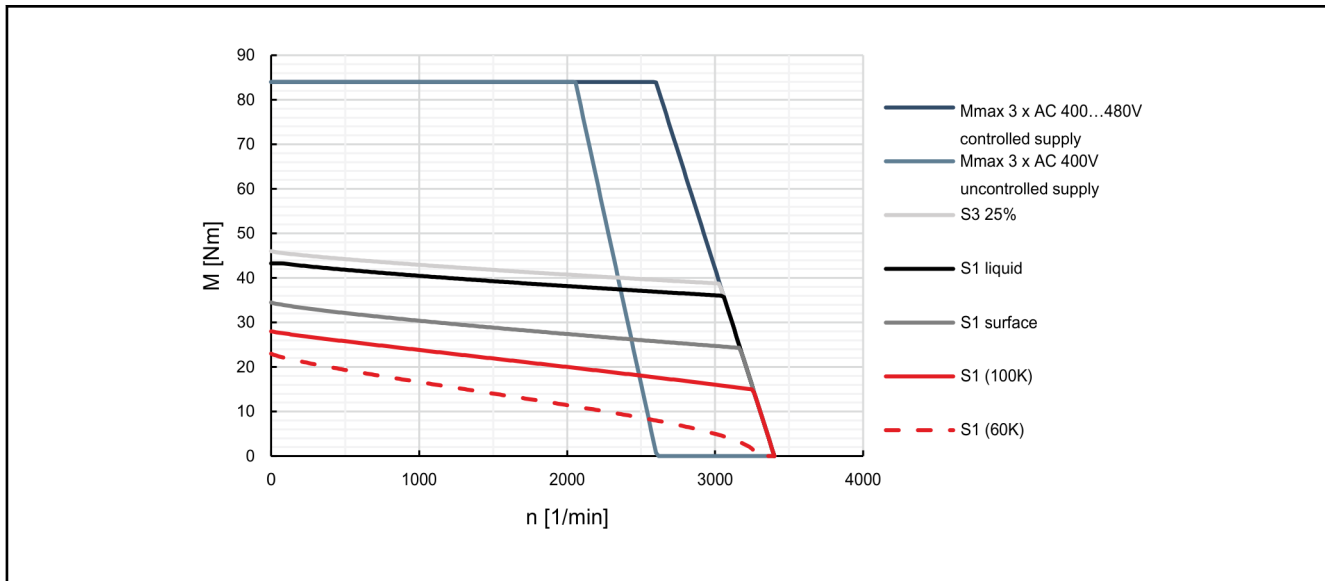

Fig. 4-39: Characteristic curves of motor MSK071E-0200

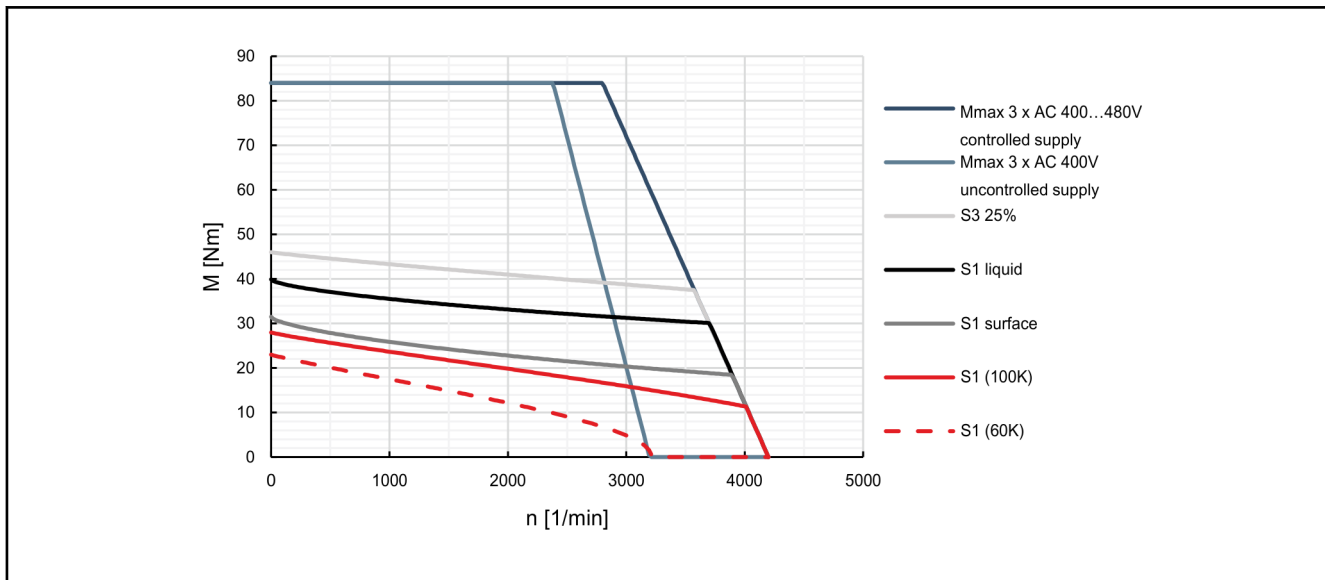

Fig. 4-40: Characteristic curves of motor MSK071E-0300

Technical data

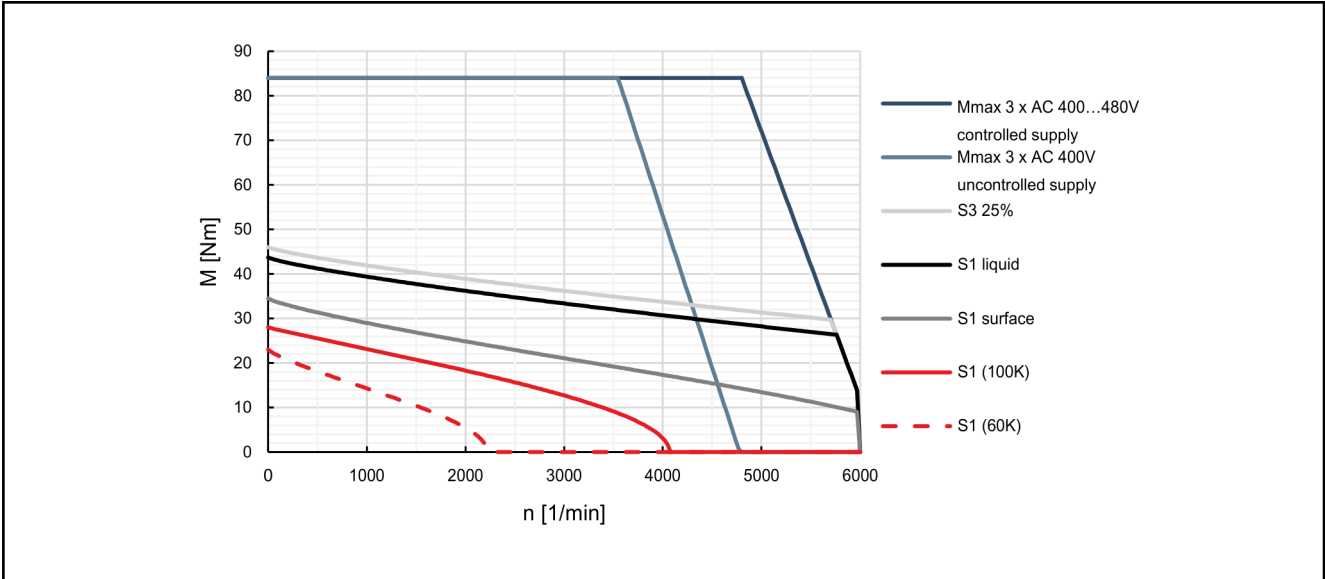

Fig. 4-41: Characteristic curves of motor MSK071E-0450

Technical data

4.22 MSK075C Technical data

Designation	Symbol	Unit	MSK075C-0200-NN	MSK075C-0300-NN	MSK075C-0450-NN
Continuous torque at standstill 60 K	$M_{0,60}$	Nm	12.0		
Continuous current at standstill 60 K	$I_{0,60(\text{eff})}$	A	6.3	8.4	12.6
Continuous torque at standstill 100 K	$M_{0,100}$	Nm	12.5		
Continuous current at standstill 100 K	$I_{0,100(\text{eff})}$	A	7.3	8.8	13.1
Continuous torque at standstill, surface	$M_{0,S}$	Nm	18.0		
Continuous current at standstill, surface	$I_{0,S(\text{eff})}$	A	9.5	12.6	18.9
Maximum torque	M_{max}	Nm	44.0		
Maximum current	$I_{\text{max}(\text{eff})}$	A	28.4	37.8	56.7
Torque constant at 20 °C	$K_{M,N}$	Nm/A	2.11	1.58	1.05
Voltage constant at 20 °C ¹⁾	$K_{\text{EMK},1000}$	V/1000 min ⁻¹	129.5	97.0	64.8
Winding resistance at 20 °C	R_{12}	Ohm	3	1.6	0.76
Winding inductance	L_{12}	mH	16.6	8.8	4.2
Leakage capacitance of the component	C_{dis}	nF	3.8	3.2	3.5
Number of pole pairs	p	-	4		
Moment of inertia of rotor	J_{red}	kg*m ²	0.00352		
Thermal time constant	$T_{\text{th,nom}}$	min	29.0		17.5
Maximum speed (electric)	$n_{\text{max el}}$	min ⁻¹	4,100	5000	6000
Sound pressure level	L_p	dB[A]	< 75		
Mass ²⁾	m	kg	14.8 (16.4)		
Ambient temperature during operation	T_{amb}	°C	0 ... 40		
Protection class (EN 60034-5)	-	-	IP65		
Thermal class (EN 60034-1)	T.CL.	-	155		

Last amended: 2014-01-21

- 1) Manufacturing tolerance ±5%
 2) (...) Motors with holding brake 1, 2, ...
 Tab. 4-21: MSK - Technical data

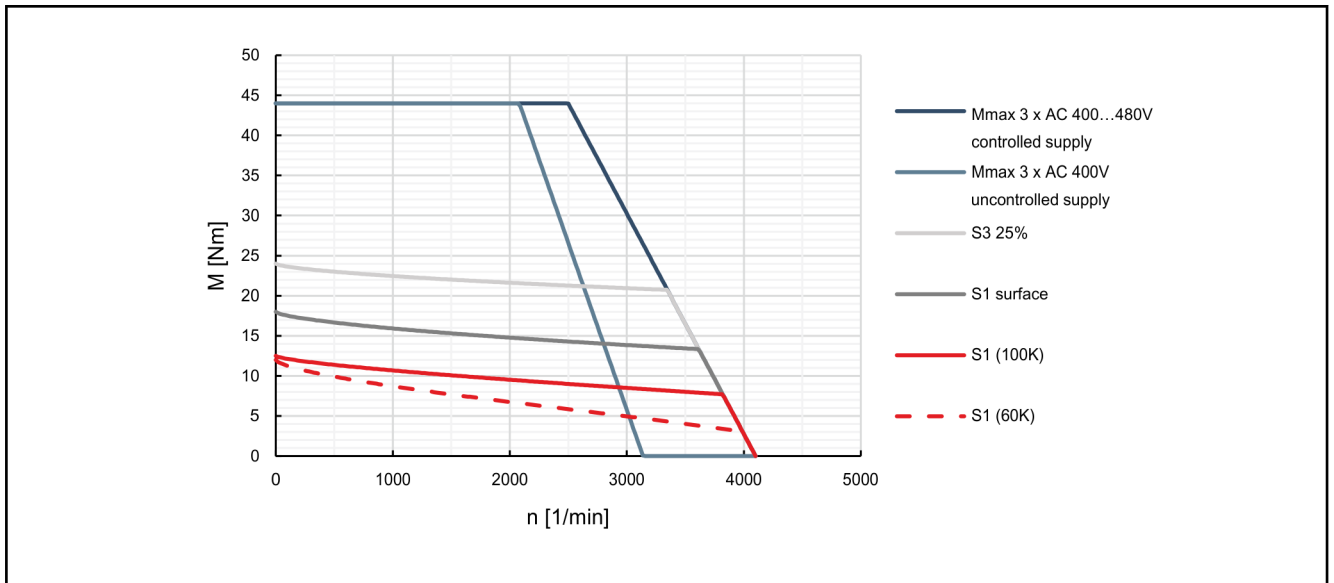

Fig. 4-42: Characteristic curves of motor MSK075C-0200

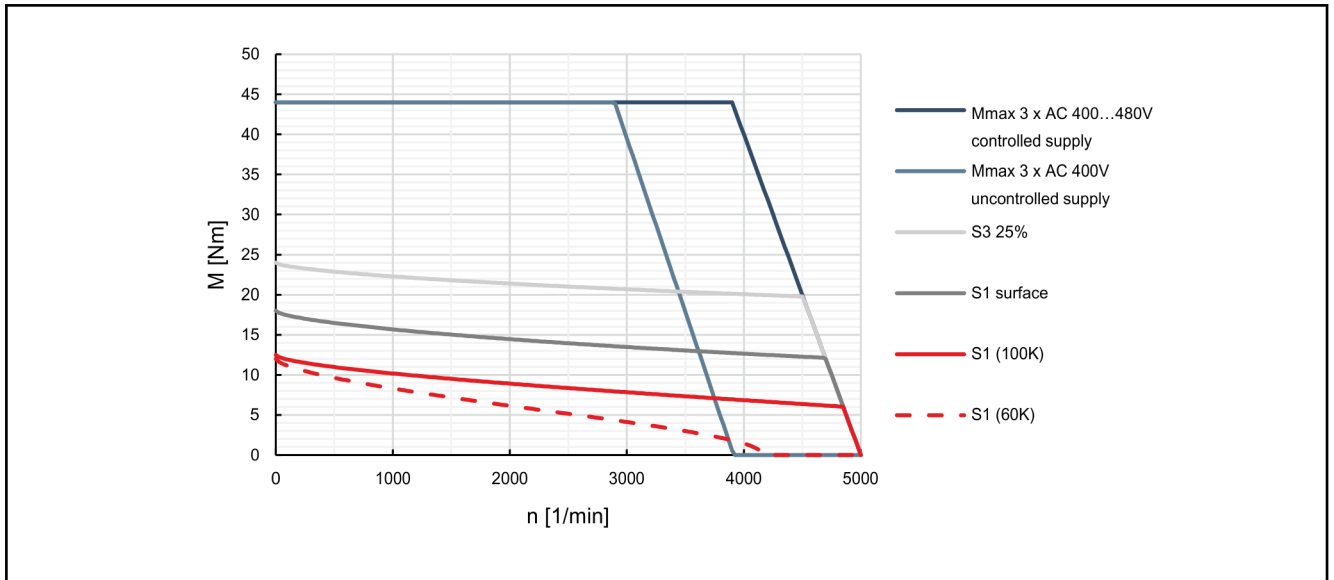

Fig. 4-43: Characteristic curves of motor MSK075C-0300

Technical data

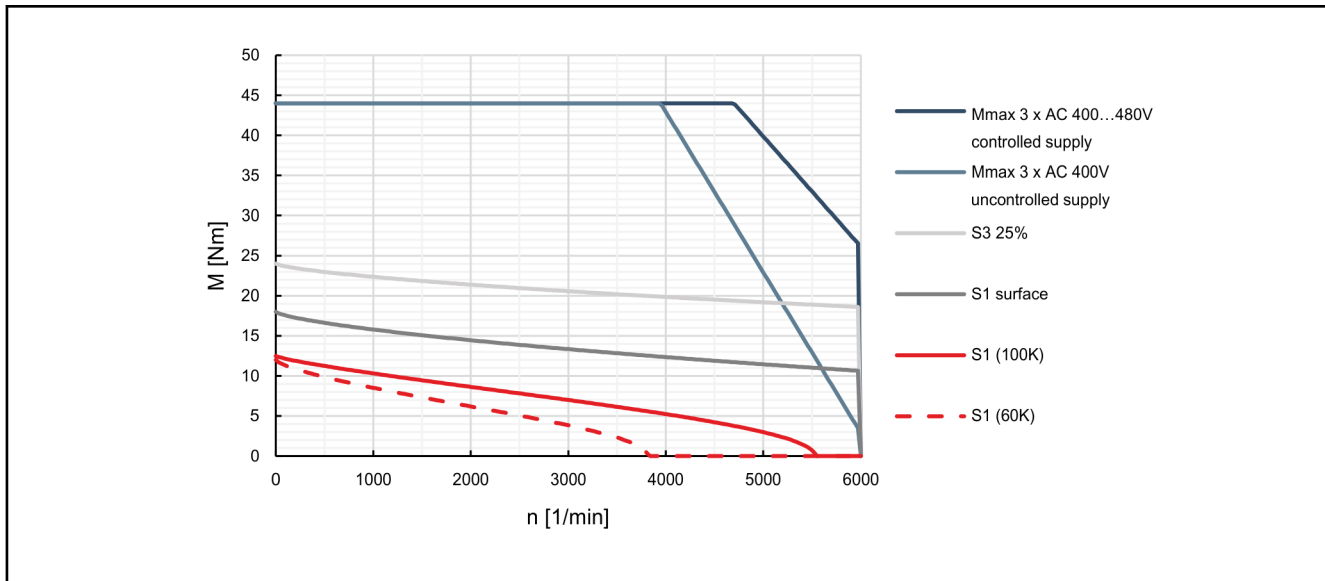

Fig. 4-44: Characteristic curves of motor MSK075C-0450

4.23 MSK075D Technical data

Designation	Symbol	Unit	MSK075D-0200-NN	MSK075D-0300-NN	MSK075D-0450-NN
Continuous torque at standstill 60 K	M_{0_60}	Nm	17.0		
Continuous current at standstill 60 K	$I_{0_60(\text{eff})}$	A	8.3	11.7	16.5
Continuous torque at standstill 100 K	M_{0_100}	Nm	18.5		
Continuous current at standstill 100 K	$I_{0_100(\text{eff})}$	A	9.0	12.7	18.0
Continuous torque at standstill, surface	M_{0_S}	Nm	25.5		
Continuous current at standstill, surface	$I_{0_S(\text{eff})}$	A	12.5	17.6	24.8
Maximum torque	M_{max}	Nm	64.0	66.0	64.0
Maximum current	$I_{\text{max}(\text{eff})}$	A	37.4	52.7	74.3
Torque constant at 20 °C	K_{M_N}	Nm/A	2.24	1.60	1.13
Voltage constant at 20 °C ¹⁾	$K_{\text{EMK_1000}}$	V/1000 min ⁻¹	138.0	98.2	69.3
Winding resistance at 20 °C	R_{12}	Ohm	1.8	0.91	0.45
Winding inductance	L_{12}	mH	11.7	5.7	2.9
Leakage capacitance of the component	C_{dis}	nF	4.6	4.7	
Number of pole pairs	p	-	4		
Moment of inertia of rotor	J_{red}	kg*m ²	0.00490		
Thermal time constant	$T_{\text{th_nom}}$	min	22.0	17.5	22.0
Maximum speed (electric)	$n_{\text{max el}}$	min ⁻¹	3800	4800	6000
Sound pressure level	L_p	dB[A]	< 75		
Mass ²⁾	m	kg	19.0 (20.1)		
Ambient temperature during operation	T_{amb}	°C	0 ... 40		
Protection class (EN 60034-5)	-	-	IP65		
Thermal class (EN 60034-1)	T.CL.	-	155		

Last amended: 2014-01-21

- 1) Manufacturing tolerance ±5%
 2) (...) Motors with holding brake 1, 2, ...
 Tab. 4-22: MSK - Technical data

Technical data

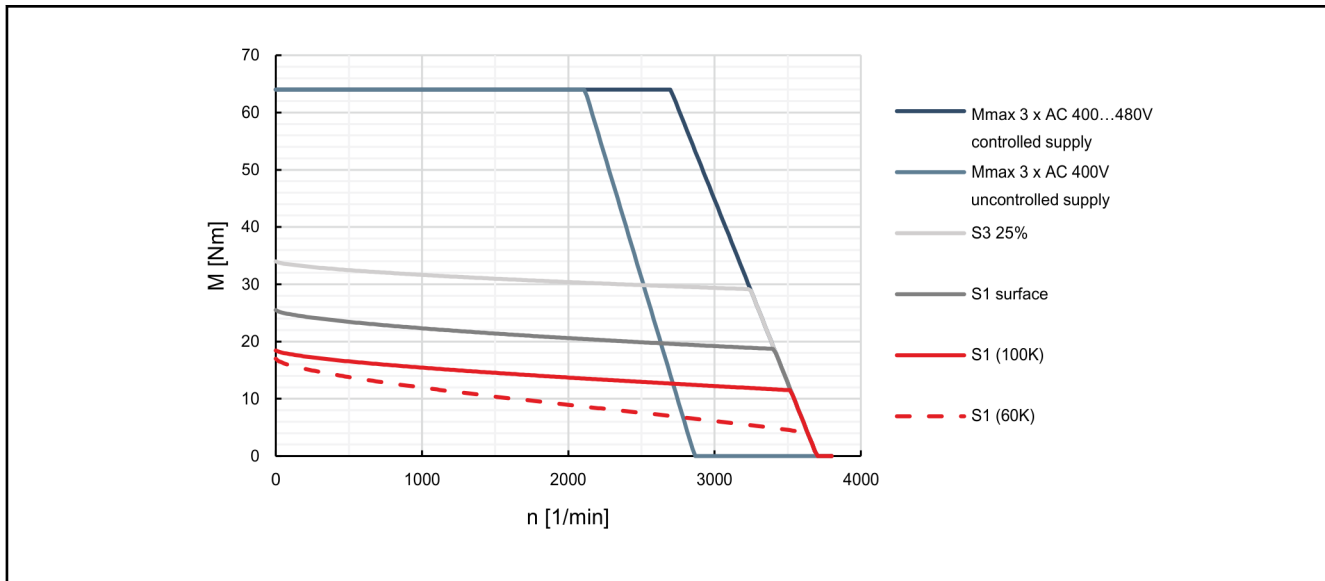

Fig. 4-45: Characteristic curves of motor MSK075D-0200

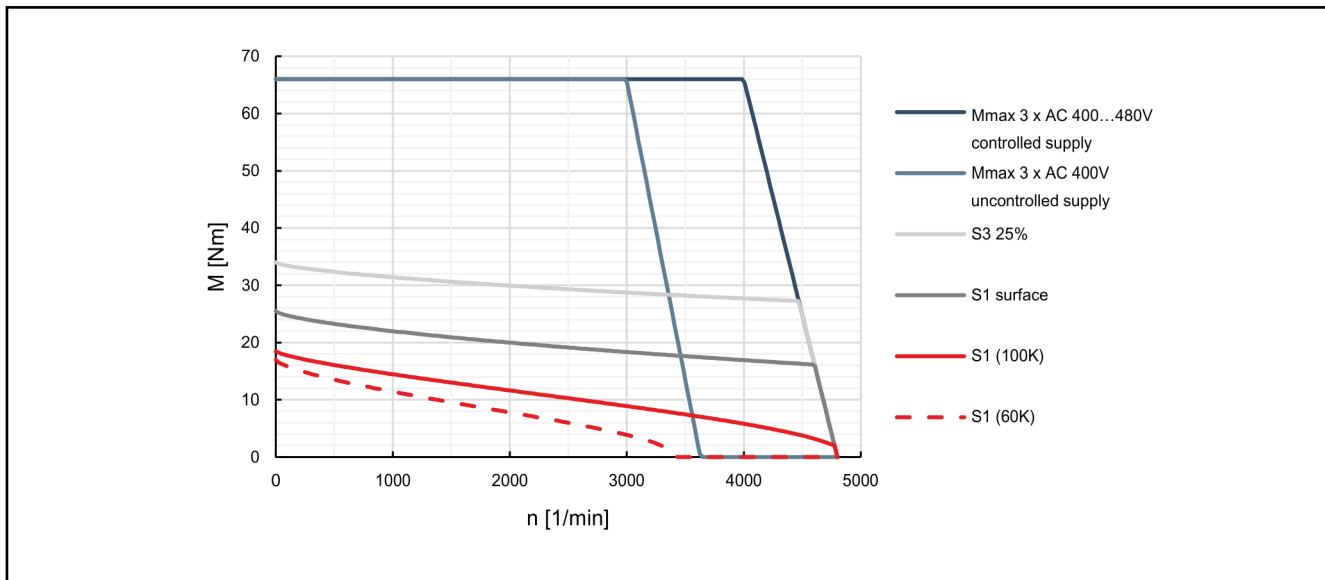

Fig. 4-46: Characteristic curves of motor MSK075D-0300

Technical data

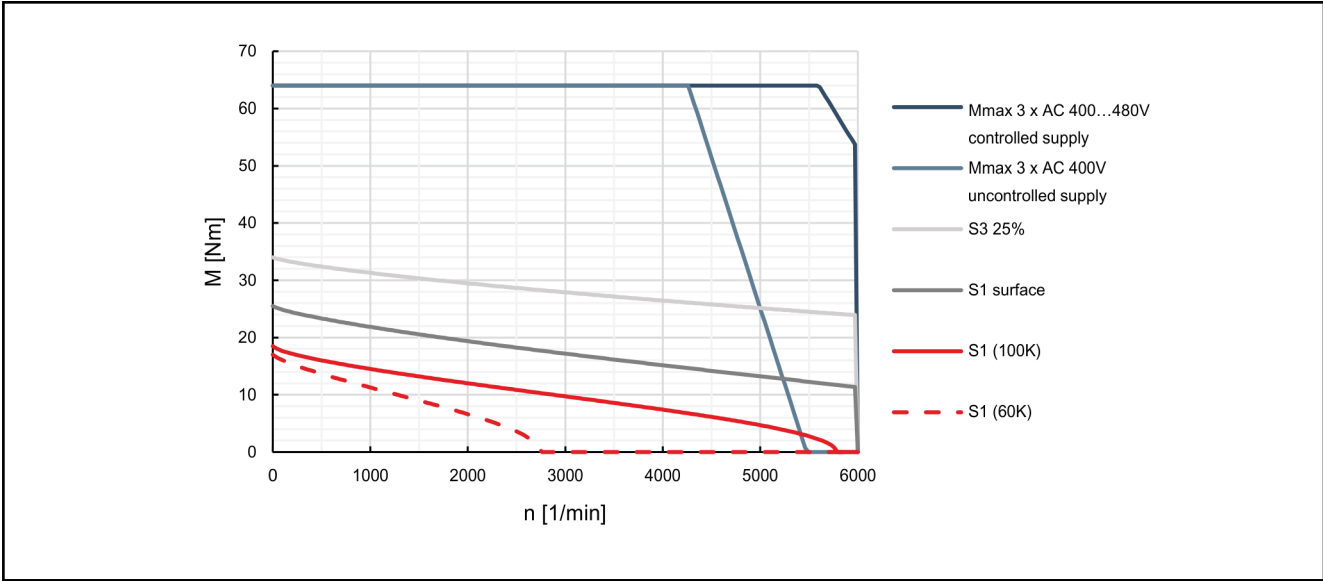

Fig. 4-47: Characteristic curves of motor MSK075D-0450

Technical data

4.24 MSK075E Technical data

Designation	Symbol	Unit	MSK075E-0 200-NN	MSK075E-0 300-FN	MSK075E-0 300-NN	MSK075E-0 450-FN	MSK075E-0 450-NN	
Continuous torque at standstill 60 K	$M_{0,60}$	Nm	21.0					
Continuous current at standstill 60 K	$I_{0,60(\text{eff})}$	A	10.2	14.2		18.6		
Continuous torque at standstill 100 K	$M_{0,100}$	Nm	23.0					
Continuous current at standstill 100 K	$I_{0,100(\text{eff})}$	A	11.2	15.6		20.4		
Continuous torque at standstill, surface	$M_{0,S}$	Nm	31.5	---	31.5	---	31.5	
Continuous current at standstill, surface	$I_{0,S(\text{eff})}$	A	+15.3	---	21.3	---	27.9	
Continuous torque at standstill, liquid	$M_{0,L}$	Nm	---	39.9	---	39.9	---	
Continuous current at standstill, liquid	$I_{0,L(\text{eff})}$	A	---	27.0	---	35.3	---	
Maximum torque	M_{max}	Nm	88.0					
Maximum current	$I_{\text{max}(\text{eff})}$	A	45.9	63.9		83.7		
Torque constant at 20 °C	$K_{M,N}$	Nm/A	2.26	1.63		1.24		
Voltage constant at 20 °C ¹⁾	$K_{\text{EMK},1000}$	V/1000 min ⁻¹	139.0	100.0		76.5		
Winding resistance at 20 °C	R_{12}	Ohm	1.24	0.65		0.39		
Winding inductance	L_{12}	mH	8.4	4.46		2.7		
Leakage capacitance of the component	C_{dis}	nF	5.8	6.5		5.6		
Number of pole pairs	p	-	4					
Moment of inertia of rotor	J_{red}	kg*m ²	0.00613					
Thermal time constant	$T_{\text{th,nom}}$	min	29.0	10.0	29.0	10.0	29.0	
Maximum speed	n_{max}	min ⁻¹	3850	5200		6000		
Sound pressure level	L_P	dB[A]	< 75					
Mass ²⁾	m	kg	22.5 (23.6) (24.1)					
Ambient temperature during operation	T_{amb}	°C	0 ... 40					
Protection class (EN 60034-5)	-	-	IP65					
Thermal class (EN 60034-1)	T_{CL}	-	155					
Data liquid cooling								
Heat loss to be dissipated	P_V	kW	---	1.00	---	1.00	---	
Inlet temperature coolant	T_{in}	°C	---	10 ... 40	---	10 ... 40	---	
Permissible coolant temperature increase at P_V	ΔT_{max}	K	---	10	---	10	---	
Required coolant flow rate at P_V	Q_{min}	l/min	---	1.5	---	1.5	---	
Pressure drop at Q_{min}	Δp	bar	---	0.5	---	0.5	---	
Maximum permissible inlet pressure	p_{max}	bar	---	6.0	---	6.0	---	
Volume of coolant duct	V_{cool}	l	---	0.06	---	0.06	---	
Material of coolant duct			Die-cast aluminum					

Last amended: 2014-01-21

- 1) Manufacturing tolerance $\pm 5\%$
2) (...) Motors with holding brake 1, 2, ...
Tab. 4-23: MSK - Technical data

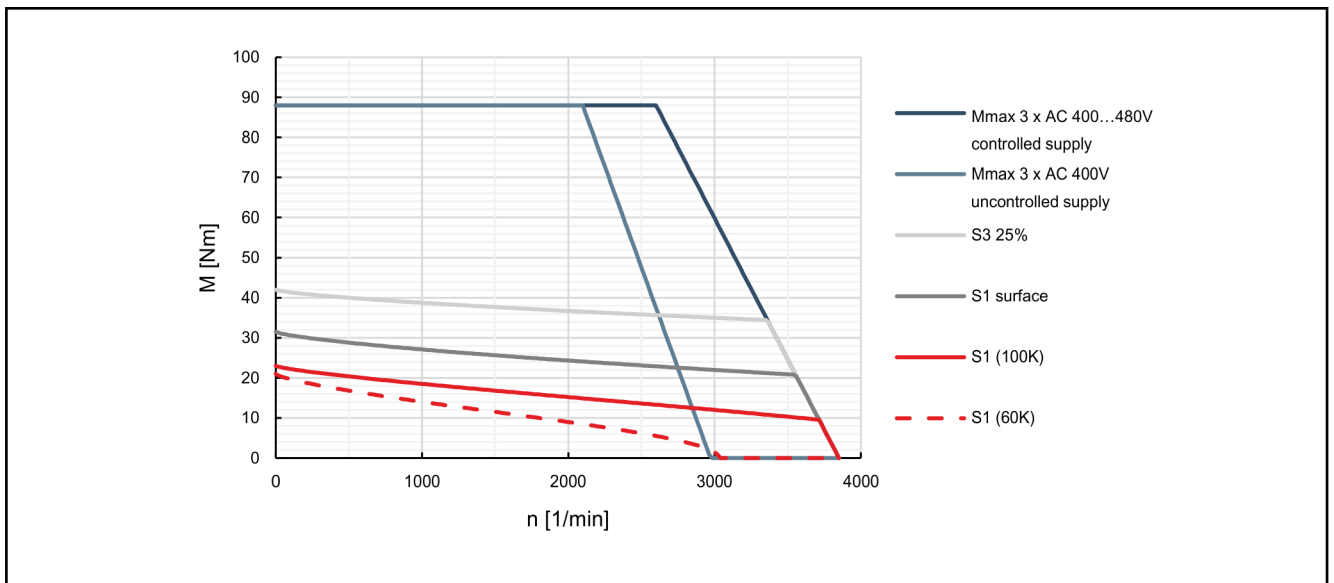

Fig. 4-48: Characteristic curves of motor MSK075E-0200

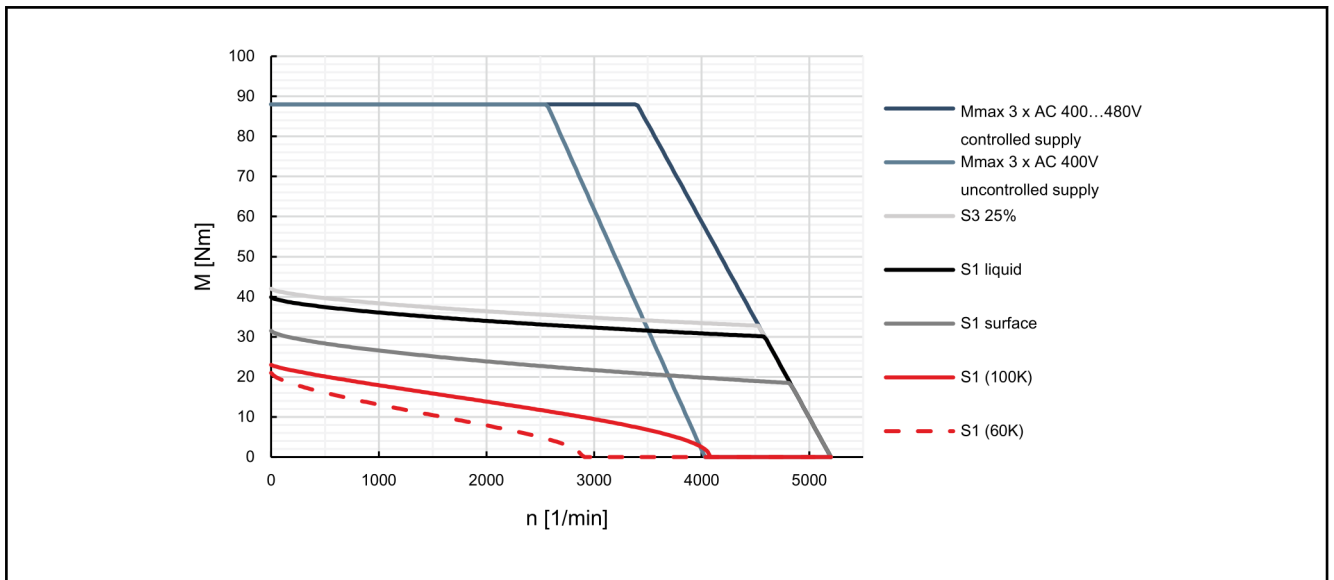

Fig. 4-49: Characteristic curves of motor MSK075E-0300

Technical data

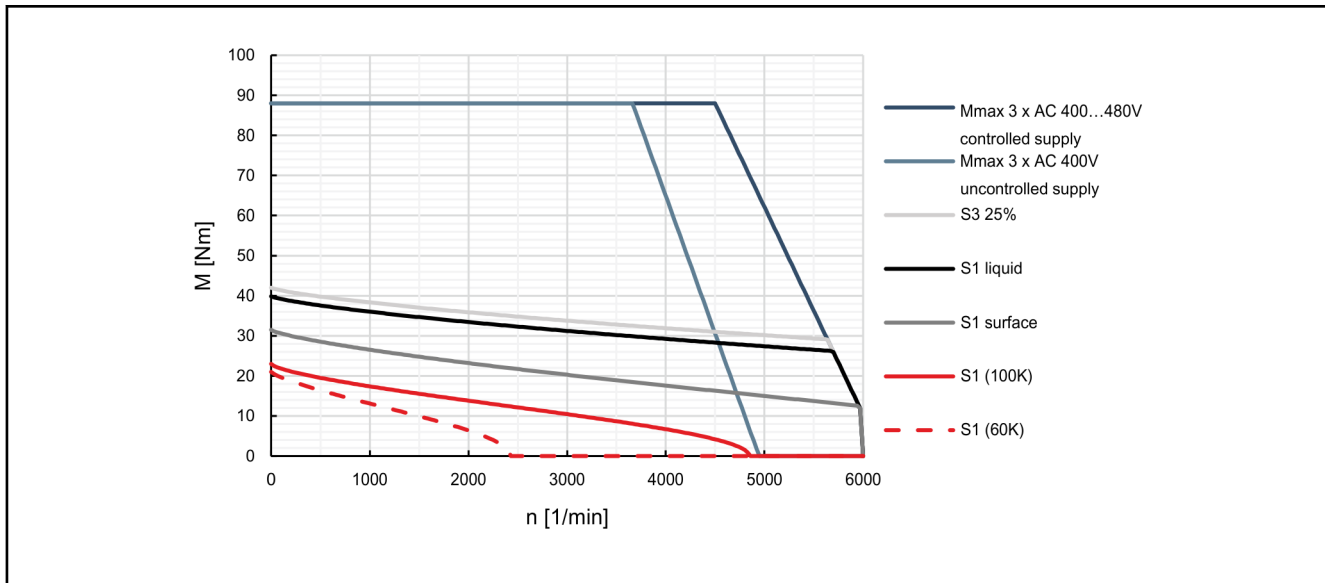

Fig. 4-50: Characteristic curves of motor MSK075E-0450

4.25 MSK076C Technical data

Designation	Symbol	Unit	MSK076C-0300-NN	MSK076C-0450-NN
Continuous torque at standstill 60 K	M_{0_60}	Nm	12.0	
Continuous current at standstill 60 K	$I_{0_60(\text{eff})}$	A	7.2	12.2
Continuous torque at standstill 100 K	M_{0_100}	Nm	13.5	
Continuous current at standstill 100 K	$I_{0_100(\text{eff})}$	A	8.1	13.7
Continuous torque at standstill, surface	M_{0_S}	Nm	18.0	
Continuous current at standstill, surface	$I_{0_S(\text{eff})}$	A	10.8	18.3
Maximum torque	M_{max}	Nm	43.5	
Maximum current	$I_{\text{max}(\text{eff})}$	A	32.4	54.9
Torque constant at 20 °C	K_{M_N}	Nm/A	1.84	1.14
Voltage constant at 20 °C ¹⁾	K_{EMK_1000}	V/1000 min ⁻¹	113.0	70.5
Winding resistance at 20 °C	R_{12}	Ohm	1.85	0.71
Winding inductance	L_{12}	mH	12.6	4.7
Leakage capacitance of the component	C_{dis}	nF	6.5	6.0
Number of pole pairs	p	-	4	
Moment of inertia of rotor	J_{red}	kg*m ²	0.00430	
Thermal time constant	$T_{\text{th_nom}}$	min	25.0	
Maximum speed (electric)	$n_{\text{max el}}$	min ⁻¹	4700	5000
Sound pressure level	L_p	dB[A]	< 75	
Mass ²⁾	m	kg	13.8 (14.9)	
Ambient temperature during operation	T_{amb}	°C	0 ... 40	
Protection class (EN 60034-5)	-	-	IP65	
Thermal class (EN 60034-1)	T.CL.	-	155	

Last amended: 2014-01-21

- 1) Manufacturing tolerance ±5%
 2) (...) Motors with holding brake 1, 2, ...
 Tab. 4-24: MSK - Technical data

Technical data

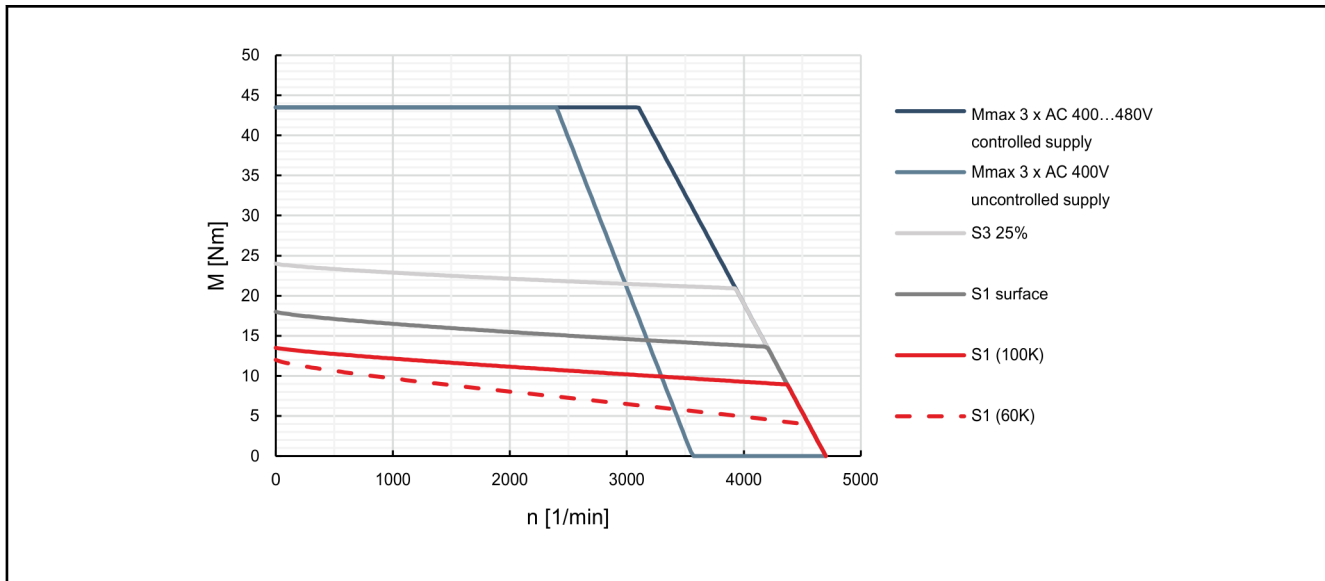

Fig. 4-51: Characteristic curves of motor MSK076C-0300

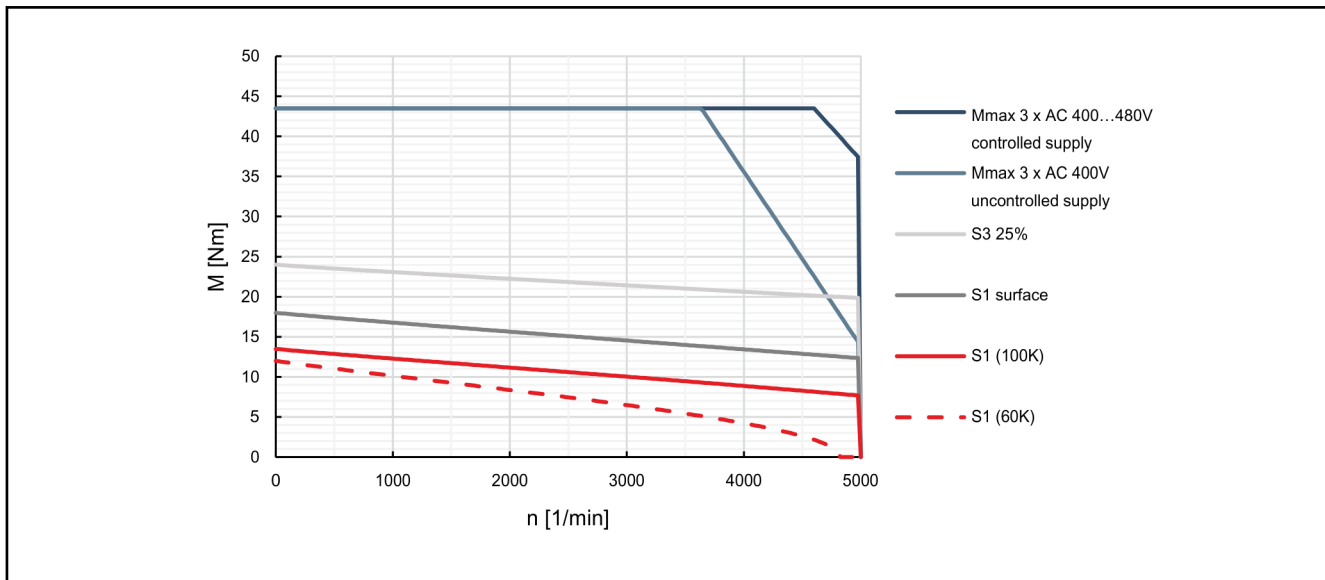

Fig. 4-52: Characteristic curves of motor MSK076C-0450

4.26 MSK100A Technical data

Designation	Symbol	Unit	MSK100A-0200-NN	MSK100A-0300-NN	MSK100A-0450-NN
Continuous torque at standstill 60 K	M_{0_60}	Nm	15.0		
Continuous current at standstill 60 K	$I_{0_60(\text{eff})}$	A	9.2	10.2	12.0
Continuous torque at standstill 100 K	M_{0_100}	Nm	17.0		
Continuous current at standstill 100 K	$I_{0_100(\text{eff})}$	A	10.4	11.6	13.6
Continuous torque at standstill, surface	M_{0_S}	Nm	22.5		
Continuous current at standstill, surface	$I_{0_S(\text{eff})}$	A	13.8	+15.3	18.0
Maximum torque	M_{max}	Nm	54.0		
Maximum current	$I_{\text{max}(\text{eff})}$	A	41.4	45.9	54.0
Torque constant at 20 °C	K_{M_N}	Nm/A	1.89	1.70	1.45
Voltage constant at 20 °C ¹⁾	K_{EMK_1000}	V/1000 min ⁻¹	116.4	104.5	89.4
Winding resistance at 20 °C	R_{12}	Ohm	1.45	1.1	0.81
Winding inductance	L_{12}	mH	13.9	11.2	7.8
Leakage capacitance of the component	C_{dis}	nF	4.8	4.6	4.9
Number of pole pairs	p	-	4		
Moment of inertia of rotor	J_{red}	kg*m ²	0.01100		
Thermal time constant	$T_{\text{th_nom}}$	min	48.0	39.0	
Maximum speed	n_{max}	min ⁻¹	4400	5200	6000
Sound pressure level	L_p	dB[A]	< 75		
Mass ²⁾	m	kg	23.0 (25.4)		
Ambient temperature during operation	T_{amb}	°C	0 ... 40		
Protection class (EN 60034-5)	-	-	IP65		
Thermal class (EN 60034-1)	T.CL.	-	155		

Last amended: 2014-01-21

- 1) Manufacturing tolerance ±5%
 2) (...) Motors with holding brake 1, 2, ...
 Tab. 4-25: MSK - Technical data

Technical data

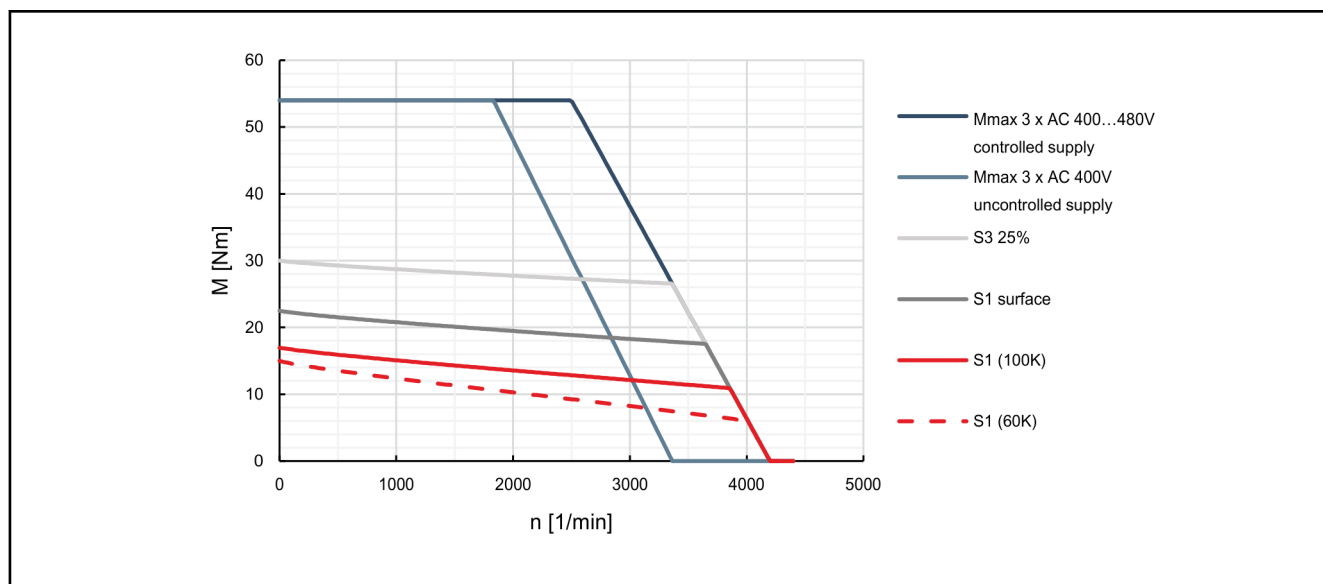

Fig. 4-53: Characteristic curves of motor MSK100A-0200

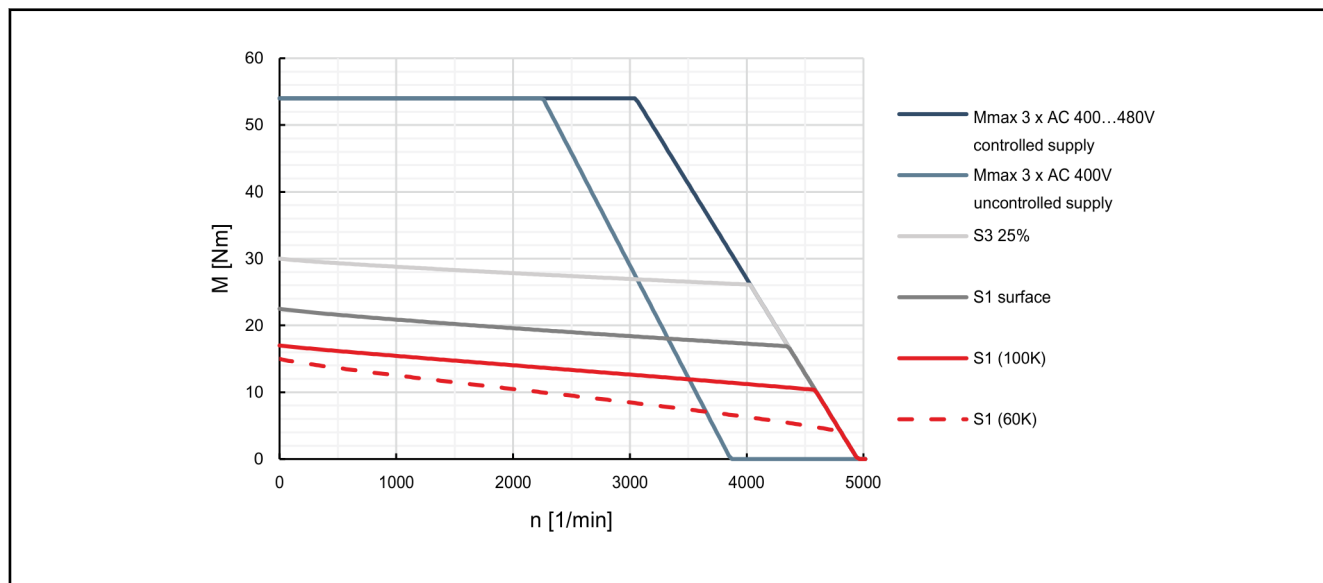

Fig. 4-54: Characteristic curves of motor MSK100A-0300

Technical data

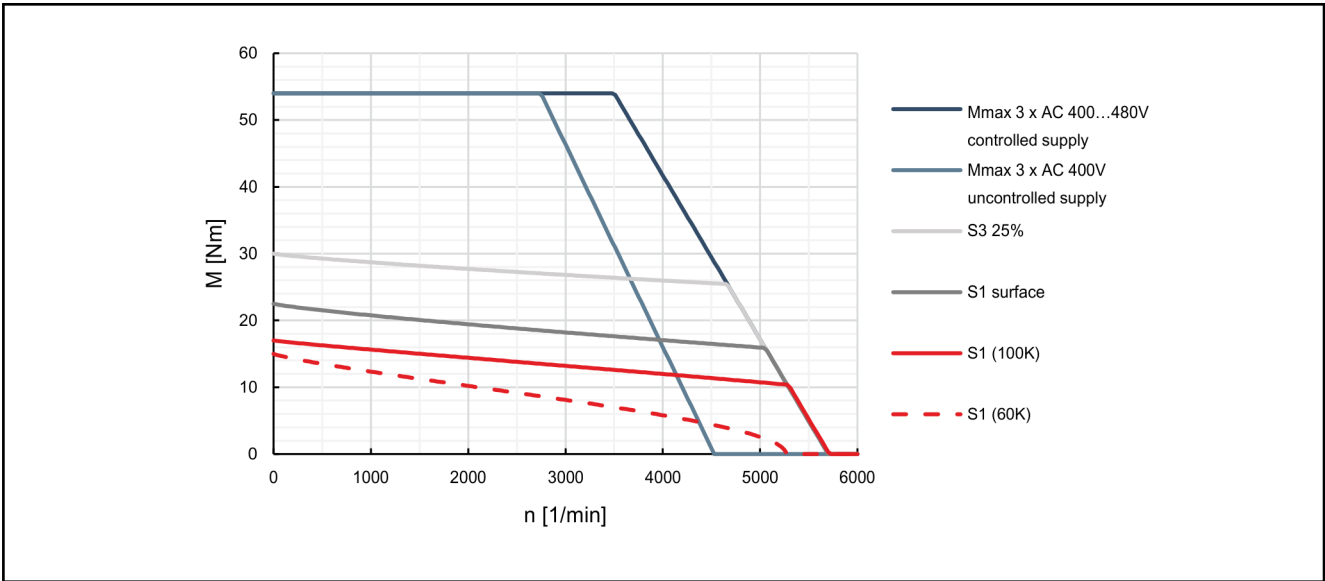

Fig. 4-55: Characteristic curves of motor MSK100A-0450

Technical data

4.27 MSK100B Technical data

Designation	Symbol	Unit	MSK100B-0200 -NN	MSK100B-0300 -NN	MSK100B-0400 -NN	MSK100B-0450 -NN
Continuous torque at standstill 60 K	$M_{0,60}$	Nm	28.0			
Continuous current at standstill 60 K	$I_{0,60(\text{eff})}$	A	14.7	17.4	24.5	28.5
Continuous torque at standstill 100 K	$M_{0,100}$	Nm	33.0			
Continuous current at standstill 100 K	$I_{0,100(\text{eff})}$	A	17.3	20.5	29.5	33.6
Continuous torque at standstill, surface	$M_{0,S}$	Nm	42.0			
Continuous current at standstill, surface	$I_{0,S(\text{eff})}$	A	22.1	26.1	35.6	42.8
Maximum torque	M_{max}	Nm	102.0			
Maximum current	$I_{\text{max}(\text{eff})}$	A	66.2	78.3	106.7	110.7
Torque constant at 20 °C	$K_{M,N}$	Nm/A	2.10	1.77	1.30	1.14
Voltage constant at 20 °C ¹⁾	$K_{EMK,1000}$	V/1000 min ⁻¹	129.5	108.5	80.0	70.0
Winding resistance at 20 °C	R_{12}	Ohm	0.58	0.43	0.23	0.17
Winding inductance	L_{12}	mH	7.6	5.5	3.1	2.2
Leakage capacitance of the component	C_{dis}	nF	10.3	9.3	10.3	
Number of pole pairs	p	-	4			
Moment of inertia of rotor	J_{red}	kg*m ²	0.01920			
Thermal time constant	$T_{\text{th,nom}}$	min	40.0			
Maximum speed (electric)	$n_{\text{max el}}$	min ⁻¹	4,100	4500		
Sound pressure level	L_p	dB[A]	< 75			
Mass ²⁾	m	kg	34.0 (36.5) (37.8)			
Ambient temperature during operation	T_{amb}	°C	0 ... 40			
Protection class (EN 60034-5)	-	-	IP65			
Thermal class (EN 60034-1)	T.CL.	-	155			

Last amended: 2014-01-21

- 1) Manufacturing tolerance ±5%
 2) (...) Motors with holding brake 1, 2, ...
 Tab. 4-26: MSK - Technical data

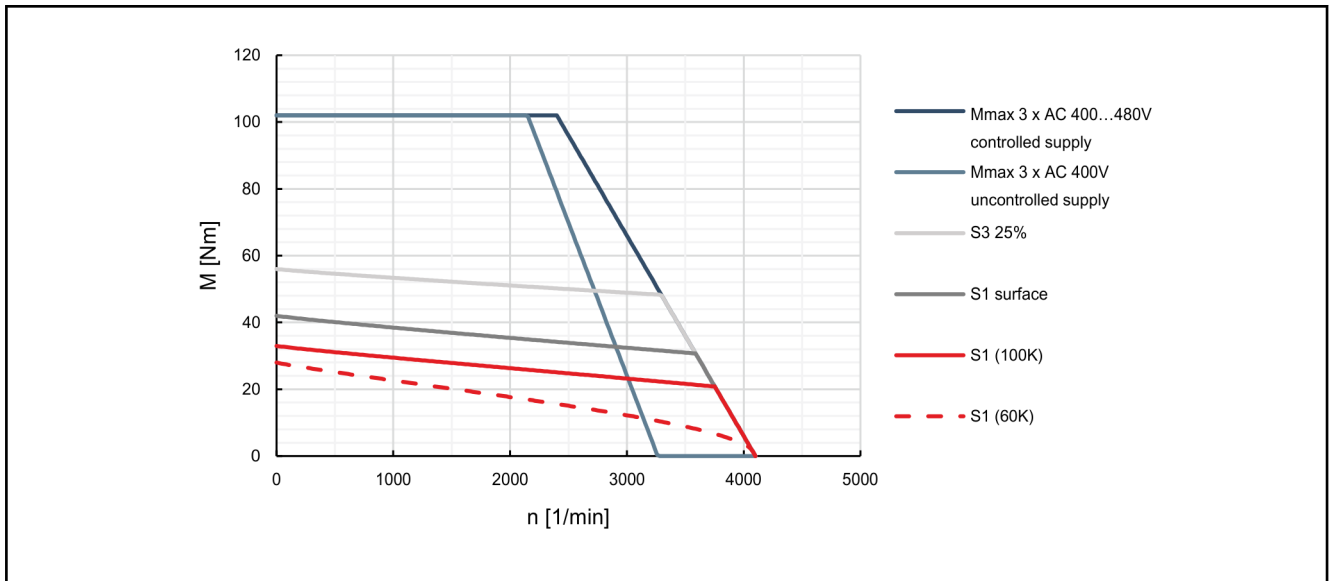

Fig. 4-56: Characteristic curves of motor MSK100B-0200

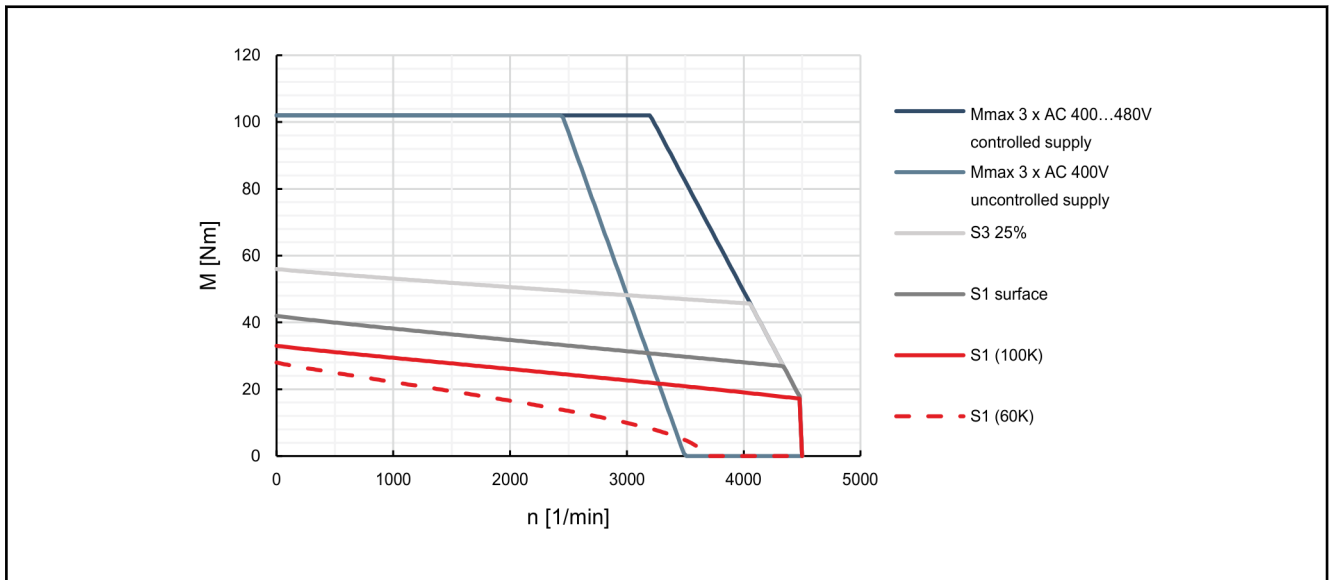

Fig. 4-57: Characteristic curves of motor MSK100B-0300

Technical data

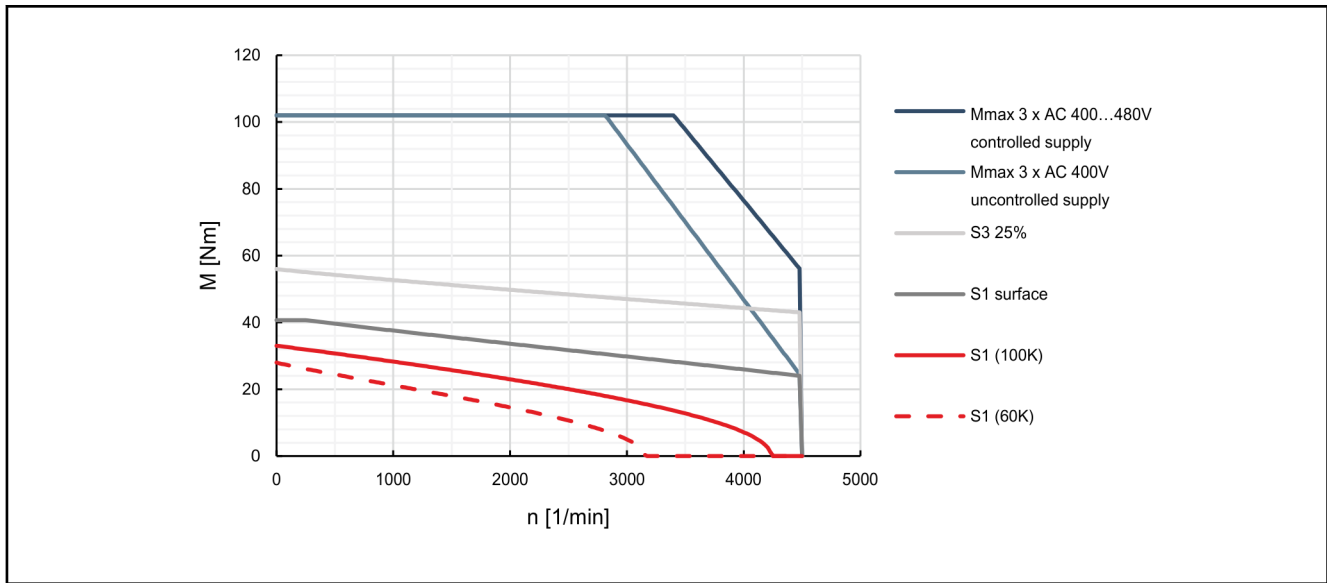

Fig. 4-58: Characteristic curves of motor MSK100B-0400

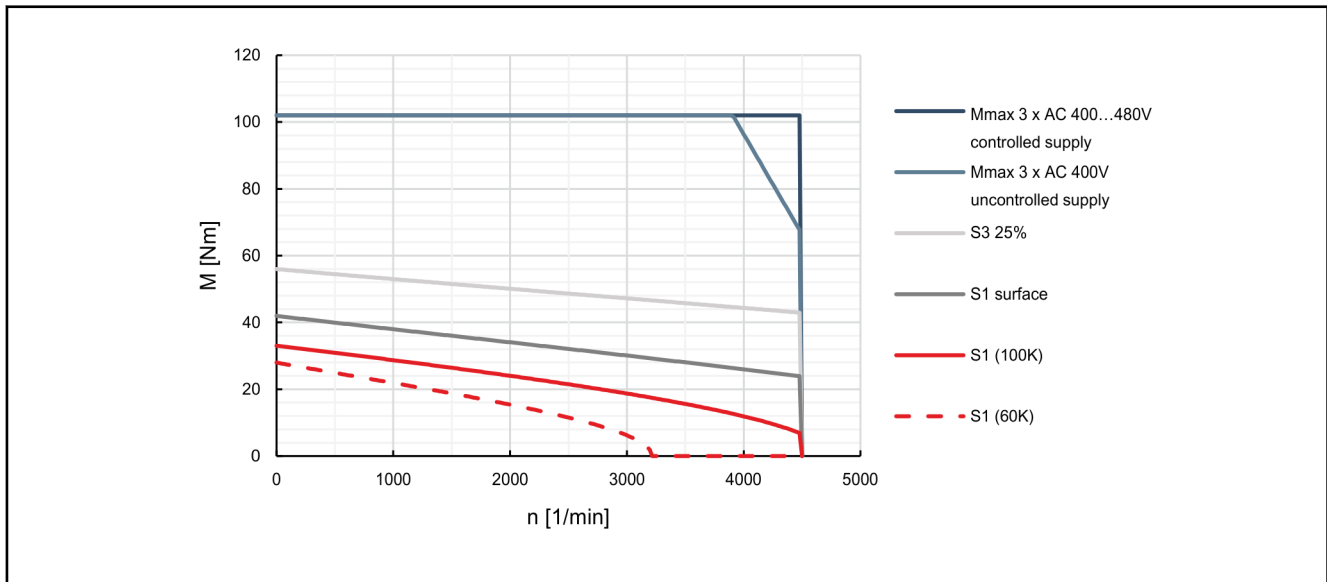

Fig. 4-59: Characteristic curves of motor MSK100B-0450

4.28 MSK100C Technical data

Designation	Symbol	Unit	MSK100C-0200-NN	MSK100C-0300-NN	MSK100C-0450-NN
Continuous torque at standstill 60 K	M_{0_60}	Nm	38.0		
Continuous current at standstill 60 K	$I_{0_60(\text{eff})}$	A	17.7	21.6	35.4
Continuous torque at standstill 100 K	M_{0_100}	Nm	43.5		
Continuous current at standstill 100 K	$I_{0_100(\text{eff})}$	A	20.3	27.0	43.5
Continuous torque at standstill, surface	M_{0_S}	Nm	57.0		
Continuous current at standstill, surface	$I_{0_S(\text{eff})}$	A	26.6	32.4	52.9
Maximum torque	M_{max}	Nm	148.0		
Maximum current	$I_{\text{max}(\text{eff})}$	A	79.7	97.2	159.3
Torque constant at 20 °C	K_{M_N}	Nm/A	2.37	1.94	1.18
Voltage constant at 20 °C ¹⁾	K_{EMK_1000}	V/1000 min ⁻¹	145.5	119.1	72.7
Winding resistance at 20 °C	R_{12}	Ohm	0.46	0.3	0.12
Winding inductance	L_{12}	mH	6.7	4.2	1.6
Leakage capacitance of the component	C_{dis}	nF	12.8	14.3	13.2
Number of pole pairs	p	-	4		
Moment of inertia of rotor	J_{red}	kg*m ²	0.02730		
Thermal time constant	$T_{\text{th_nom}}$	min	90.0		
Maximum speed (electric)	$n_{\text{max el}}$	min ⁻¹	3500	4500	4000
Sound pressure level	L_p	dB[A]	< 75		
Mass ²⁾	m	kg	45.1 (48.9)		
Ambient temperature during operation	T_{amb}	°C	0 ... 40		
Protection class (EN 60034-5)	-	-	IP65		
Thermal class (EN 60034-1)	T.CL.	-	155		

Last amended: 2014-01-21

- 1) Manufacturing tolerance ±5%
 2) (...) Motors with holding brake 1, 2, ...
 Tab. 4-27: MSK - Technical data

Technical data

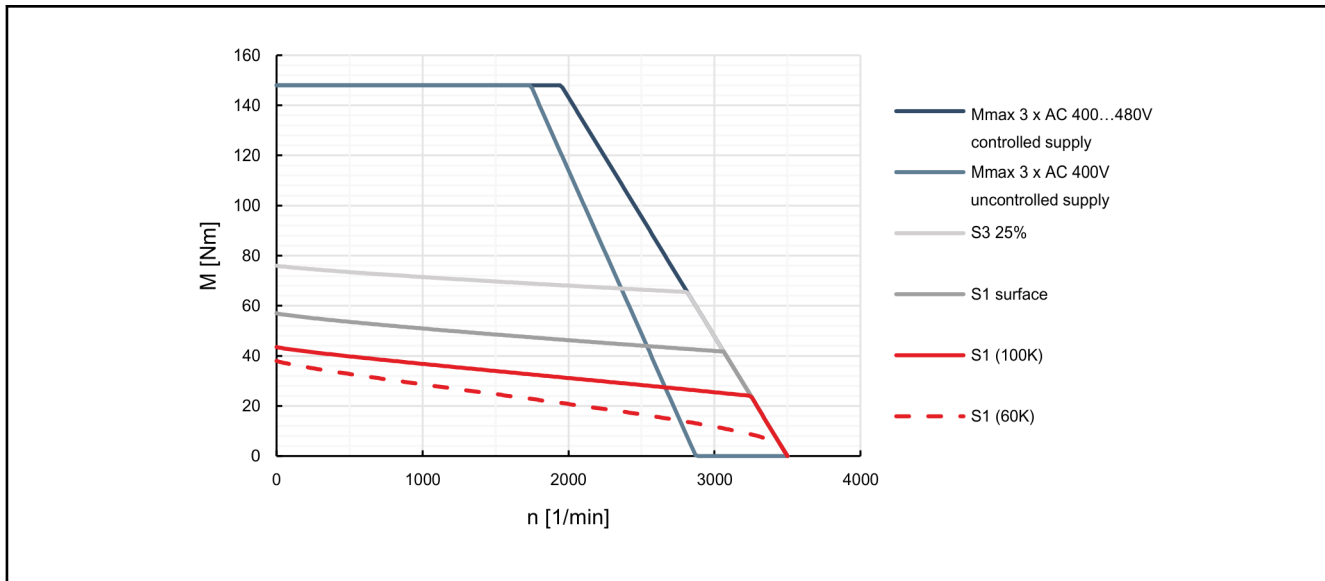

Fig. 4-60: Characteristic curves of motor MSK100C-0200

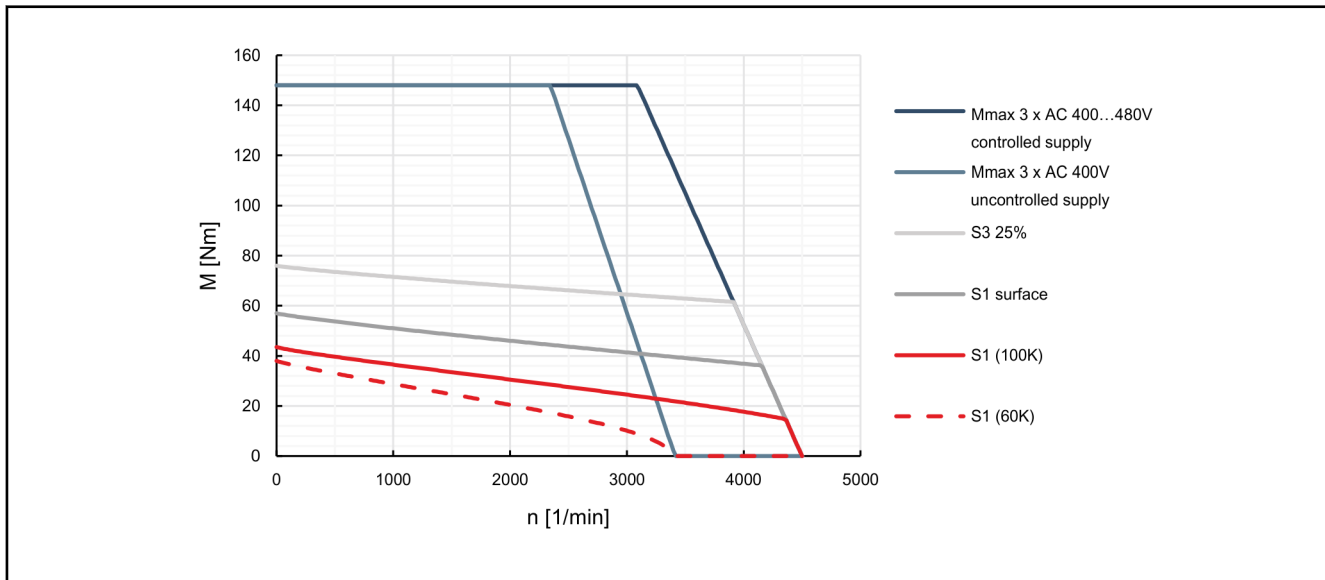

Fig. 4-61: Characteristic curves of motor MSK100C-0300

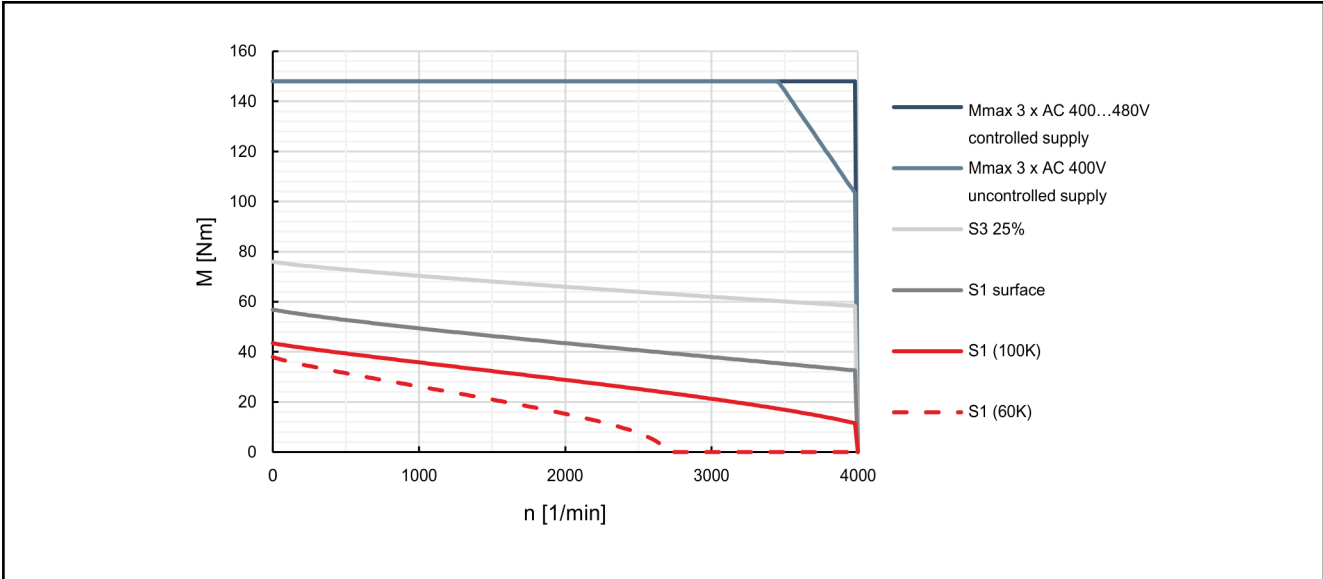

Fig. 4-62: Characteristic curves of motor MSK100C-0450

Technical data

4.29 MSK100D Technical data

Designation	Symbol	Unit	MSK100D-0200-NN	MSK100D-0300-NN	MSK100D-0350-NN
Continuous torque at standstill 60 K	M_{0_60}	Nm	48.0		
Continuous current at standstill 60 K	$I_{0_60(\text{eff})}$	A	13.0	20.7	29.9
Continuous torque at standstill 100 K	M_{0_100}	Nm	57.0		
Continuous current at standstill 100 K	$I_{0_100(\text{eff})}$	A	15.4	24.8	35.5
Continuous torque at standstill, surface	M_{0_S}	Nm	72.0		
Continuous current at standstill, surface	$I_{0_S(\text{eff})}$	A	19.5	31.1	44.9
Maximum torque	M_{max}	Nm	187.0		185.0
Maximum current	$I_{\text{max}(\text{eff})}$	A	58.5	93.2	135.0
Torque constant at 20 °C	K_{M_N}	Nm/A	4.28	2.61	1.86
Voltage constant at 20 °C ¹⁾	$K_{\text{EMK_1000}}$	V/1000 min ⁻¹	263.5	161.0	114.5
Winding resistance at 20 °C	R_{12}	Ohm	0.97	0.35	0.2
Winding inductance	L_{12}	mH	14.8	5.65	3.2
Leakage capacitance of the component	C_{dis}	nF	17.6	16.0	18.0
Number of pole pairs	p	-	4		
Moment of inertia of rotor	J_{red}	kg*m ²	0.03500		
Thermal time constant	$T_{\text{th_nom}}$	min	90.0		
Maximum speed (electric)	$n_{\text{max el}}$	min ⁻¹	2000	3000	
Sound pressure level	L_p	dB[A]	< 75		
Mass ²⁾	m	kg	56.0 (59.8)		
Ambient temperature during operation	T_{amb}	°C	0 ... 40		
Protection class (EN 60034-5)	-	-	IP65		
Thermal class (EN 60034-1)	T.CL.	-	155		

Last amended: 2017-03-15

- 1) Manufacturing tolerance ±5%
 2) (...) Motors with holding brake 1, 2, ...
 Tab. 4-28: MSK - Technical data

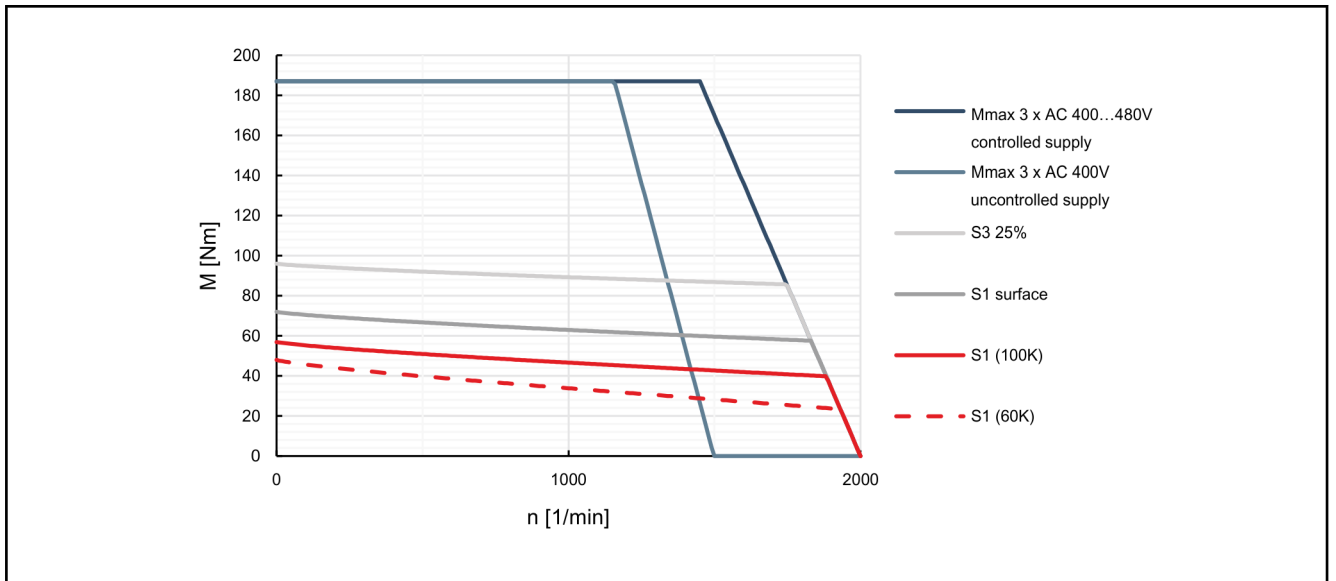

Fig. 4-63: Characteristic curves of motor MSK100D-0200

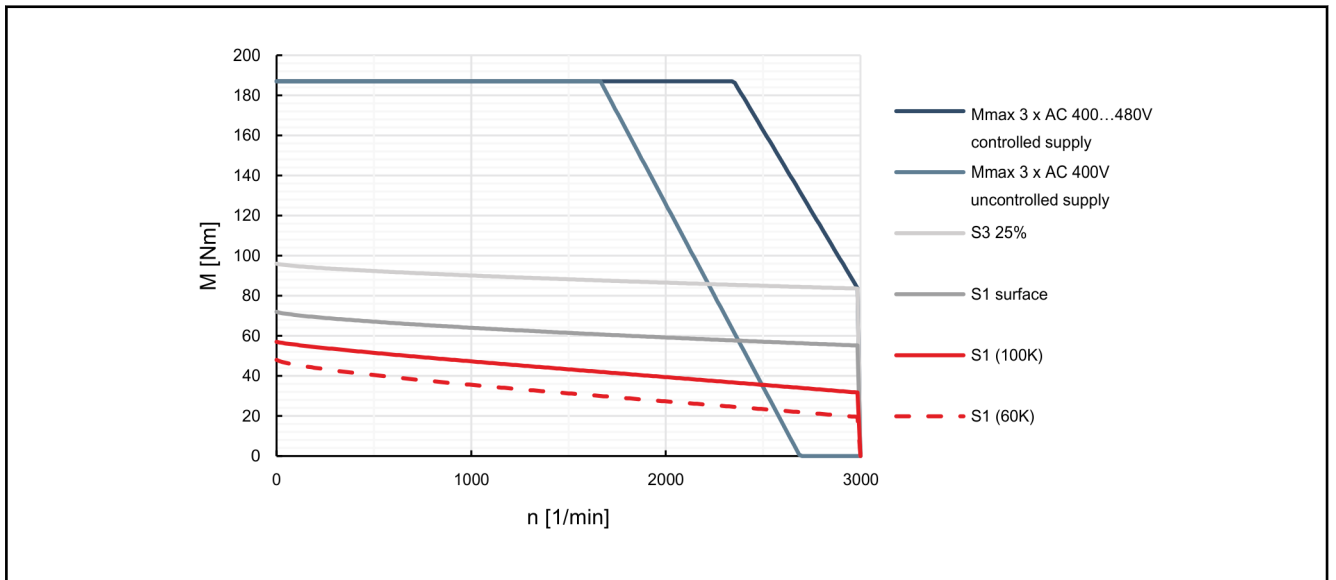

Fig. 4-64: Characteristic curves of motor MSK100D-0300

Technical data

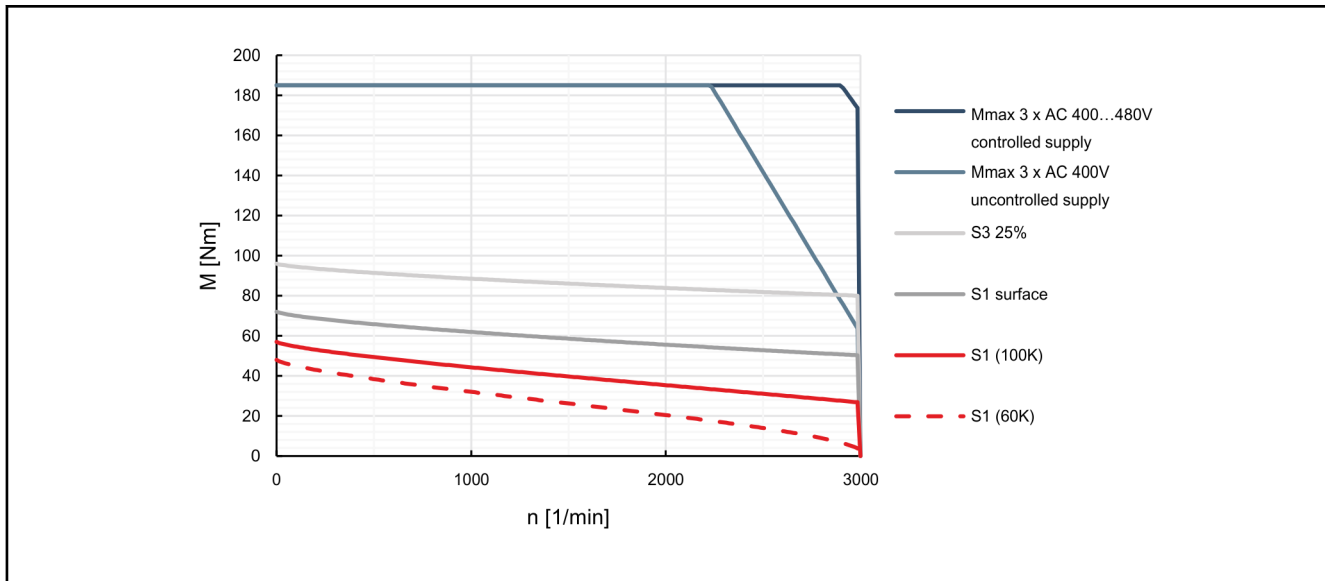

Fig. 4-65: Characteristic curves of motor MSK100D-0350

4.30 MSK101C Technical data

Designation	Symbol	Unit	MSK101C -0200-FN	MSK101C -0200-NN	MSK101C -0300-FN	MSK101C -0300-NN	MSK101C -0450-FN	MSK101C -0450-NN
Continuous torque at standstill 60 K	$M_{0,60}$	Nm	32.0					
Continuous current at standstill 60 K	$I_{0,60(\text{eff})}$	A	14.9		18.7		25.1	
Continuous torque at standstill 100 K	$M_{0,100}$	Nm	36.5					
Continuous current at standstill 100 K	$I_{0,100(\text{eff})}$	A	17.0		21.3		37.7	28.6
Continuous torque at standstill, surface	$M_{0,S}$	Nm	---	48.0	---	48.0	---	48.0
Continuous current at standstill, surface	$I_{0,S(\text{eff})}$	A	---	22.4	---	28.1	---	37.7
Continuous torque at standstill, liquid	$M_{0,L}$	Nm	60.8	---	60.8	---	60.8	---
Continuous current at standstill, liquid	$I_{0,L(\text{eff})}$	A	28.3	---	35.3	---	47.7	---
Maximum torque	M_{max}	Nm	110.0					
Maximum current	$I_{\text{max}(\text{eff})}$	A	67.1		84.2		113.0	
Torque constant at 20 °C	$K_{M,N}$	Nm/A	2.37		1.88		1.40	
Voltage constant at 20 °C ¹⁾	$K_{EMK,1000}$	V/1000 min ⁻¹	146.0		115.7		86.3	
Winding resistance at 20 °C	R_{12}	Ohm	0.68		0.45		0.23	
Winding inductance	L_{12}	mH	9.7		6.0		3.3	
Leakage capacitance of the component	C_{dis}	nF	6.2				6.8	
Number of pole pairs	p	-	4					
Moment of inertia of rotor	J_{red}	kg*m ²	0.00650					
Thermal time constant	$T_{\text{th,nom}}$	min	5.0	36.0	5.0	38.0	5.0	36.0
Maximum speed (electric)	$n_{\text{max el}}$	min ⁻¹	3300		4500		5800	
Sound pressure level	L_P	dB[A]	< 75					
Mass ²⁾	m	kg	28.3 (32.1)					
Ambient temperature during operation	T_{amb}	°C	0 ... 40					
Protection class (EN 60034-5)	-	-	IP65					
Thermal class (EN 60034-1)	T.CL.	-	155					
Data liquid cooling								
Heat loss to be dissipated	P_V	kW	1.20	---	1.20	---	1.20	---
Inlet temperature coolant	T_{in}	°C	10 ... 40	---	10 ... 40	---	10 ... 40	---
Permissible coolant temperature increase at P_V	ΔT_{max}	K	10	---	10	---	10	---
Required coolant flow rate at P_V	Q_{min}	l/min	1.7	---	1.7	---	1.7	---
Pressure drop at Q_{min}	Δp	bar	0.6	---	0.6	---	0.6	---
Maximum permissible inlet pressure	p_{max}	bar	6.0	---	6.0	---	6.0	---
Volume of coolant duct	V_{cool}	l	0.09	---	0.09	---	0.09	---
Material of coolant duct			Die-cast aluminum					

Last amended: 2014-09-09

- 1) Manufacturing tolerance ±5%
 2) (...) Motors with holding brake 1, 2, ...
 Tab. 4-29: MSK - Technical data

Technical data

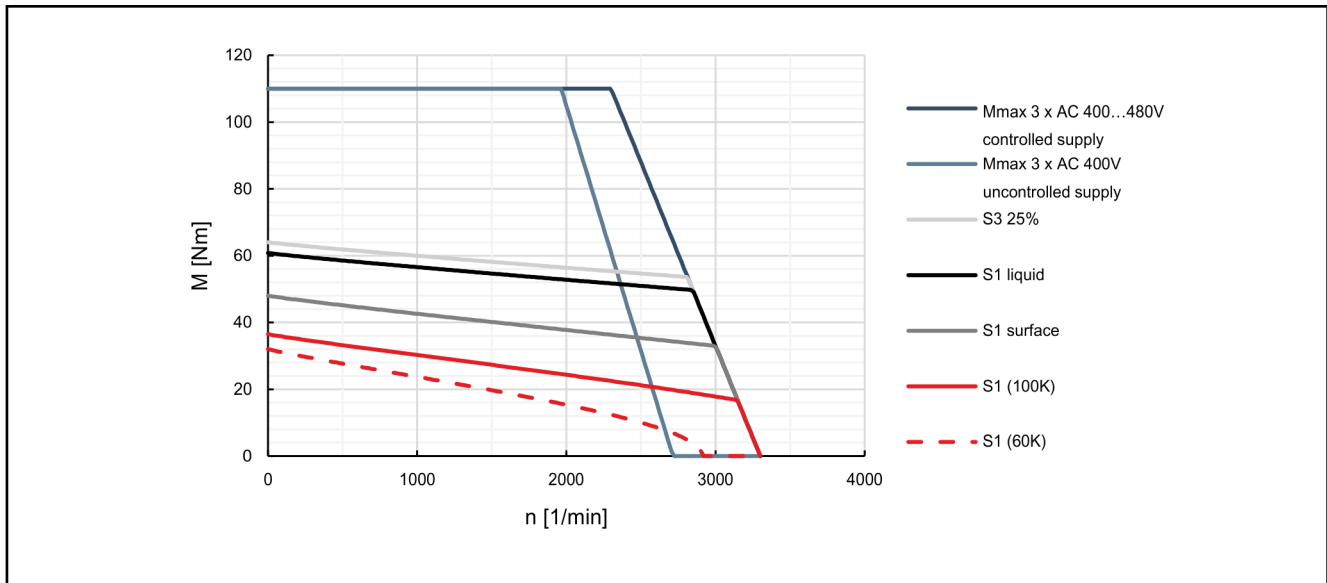

Fig. 4-66: Characteristic curves of motor MSK101C-0200

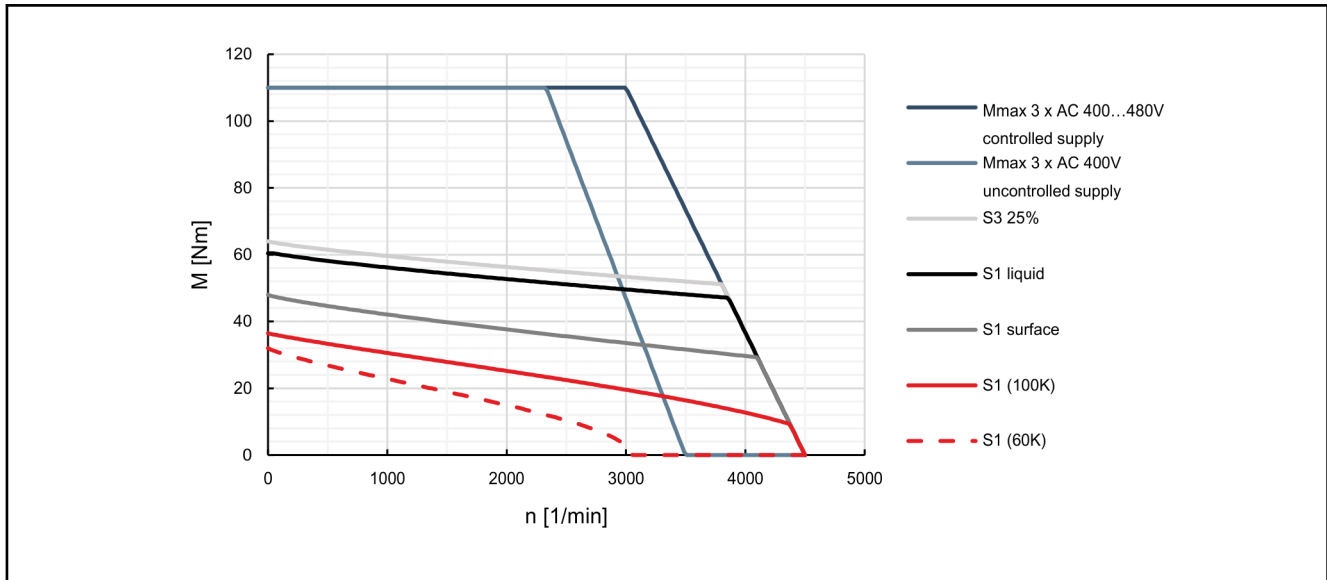

Fig. 4-67: Characteristic curves of motor MSK101C-0300

Technical data

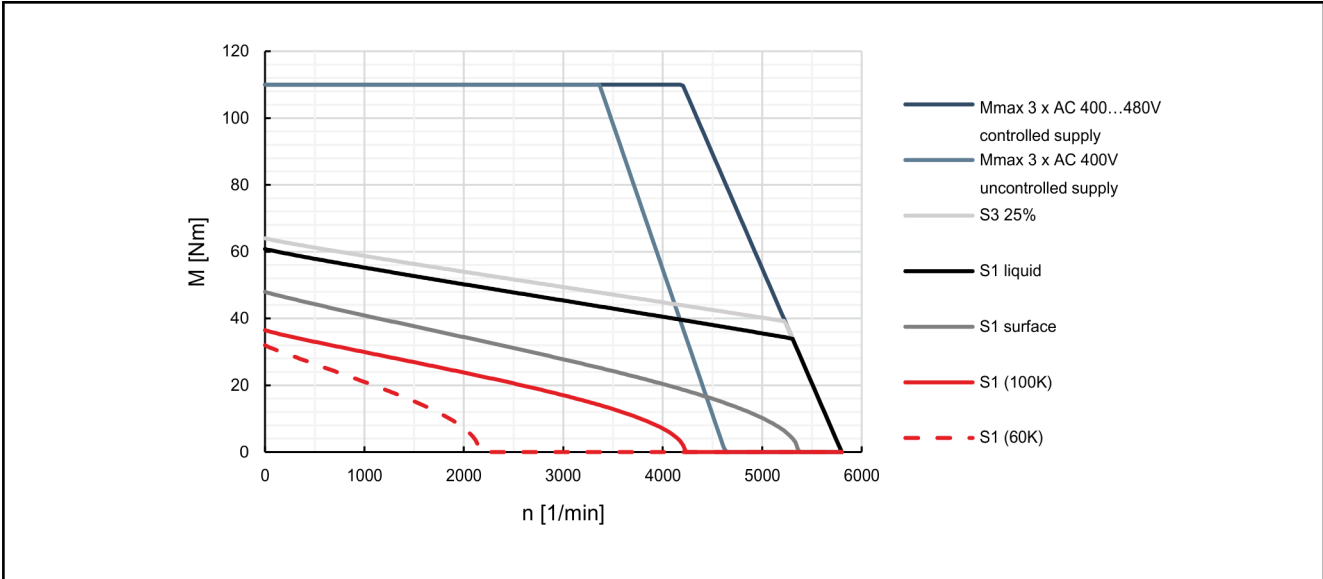

Fig. 4-68: Characteristic curves of motor MSK101C-0450

Technical data

4.31 MSK101D Technical data

Designation	Symbol	Unit	MSK101D -0200-FN	MSK101D -0200-NN	MSK101D -0300-FN	MSK101D -0300-NN	MSK101D -0450-FN	MSK101D -0450-NN
Continuous torque at standstill 60 K	$M_{0,60}$	Nm	50.0					
Continuous current at standstill 60 K	$I_{0,60(\text{eff})}$	A	22.2		30.6		41.7	
Continuous torque at standstill 100 K	$M_{0,100}$	Nm	57.0					
Continuous current at standstill 100 K	$I_{0,100(\text{eff})}$	A	26.8		34.9		50.6	
Continuous torque at standstill, surface	$M_{0,S}$	Nm	---	75.0	---	75.0	---	75.0
Continuous current at standstill, surface	$I_{0,S(\text{eff})}$	A	---	33.3	---	45.9	---	66.0
Continuous torque at standstill, liquid	$M_{0,L}$	Nm	95.0	---	95.0	---	95.0	---
Continuous current at standstill, liquid	$I_{0,L(\text{eff})}$	A	43.3	---	58.1	---	79.2	---
Maximum torque	M_{max}	Nm	160.0					
Maximum current	$I_{\text{max}(\text{eff})}$	A	99.9		137.7		187.7	
Torque constant at 20 °C	$K_{M,N}$	Nm/A	2.48		1.80		1.32	
Voltage constant at 20 °C ¹⁾	$K_{\text{EMK},1000}$	V/1000 min ⁻¹	152.0		113.0		81.0	
Winding resistance at 20 °C	R_{12}	Ohm	0.35		0.19		0.1	
Winding inductance	L_{12}	mH	6.0		3.2		1.7	
Leakage capacitance of the component	C_{dis}	nF	13.2		9.1		13.2	
Number of pole pairs	p	-	4					
Moment of inertia of rotor	J_{red}	kg*m ²	0.00932					
Thermal time constant	$T_{\text{th,nom}}$	min	5.0	100.0	5.0	100.0	5.0	100.0
Maximum speed (electric)	$n_{\text{max el}}$	min ⁻¹	3400		4600		6000	
Sound pressure level	L_P	dB[A]	< 75					
Mass ²⁾	m	kg	40.0 (43.8) (46.2)					
Ambient temperature during operation	T_{amb}	°C	0 ... 40					
Protection class (EN 60034-5)	-	-	IP65					
Thermal class (EN 60034-1)	T_{CL}	-	155					
Data liquid cooling								
Heat loss to be dissipated	P_V	kW	1.35	---	1.35	---	1.35	---
Inlet temperature coolant	T_{in}	°C	10 ... 40		10 ... 40		10 ... 40	
Permissible coolant temperature increase at P_V	ΔT_{max}	K	10	---	10	---	10	---
Required coolant flow rate at P_V	Q_{min}	l/min	2.0	---	2.0	---	2.0	---
Pressure drop at Q_{min}	Δp	bar	0.7	---	0.7	---	0.7	---
Maximum permissible inlet pressure	p_{max}	bar	6.0	---	6.0	---	6.0	---
Volume of coolant duct	V_{cool}	l	0.11	---	0.11	---	0.11	---
Material of coolant duct			Die-cast aluminum					

Last amended: 2014-01-21

- 1) Manufacturing tolerance $\pm 5\%$
2) (...) Motors with holding brake 1, 2, ...
Tab. 4-30: MSK - Technical data

Technical data

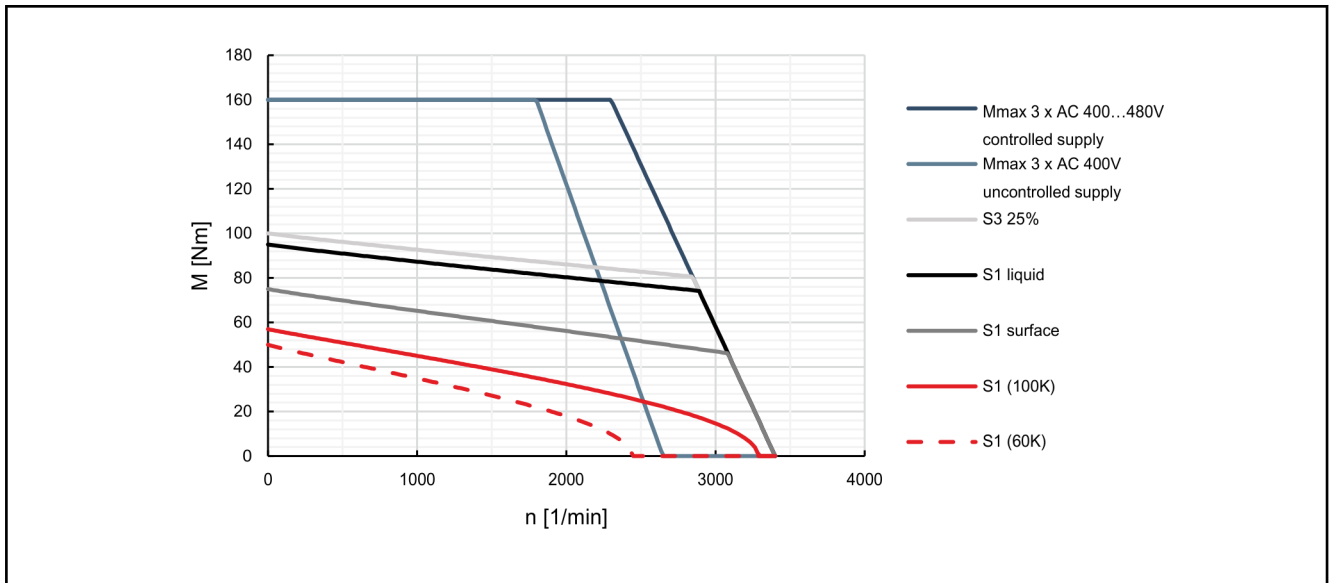

Fig. 4-69: Characteristic curves of motor MSK101D-0200

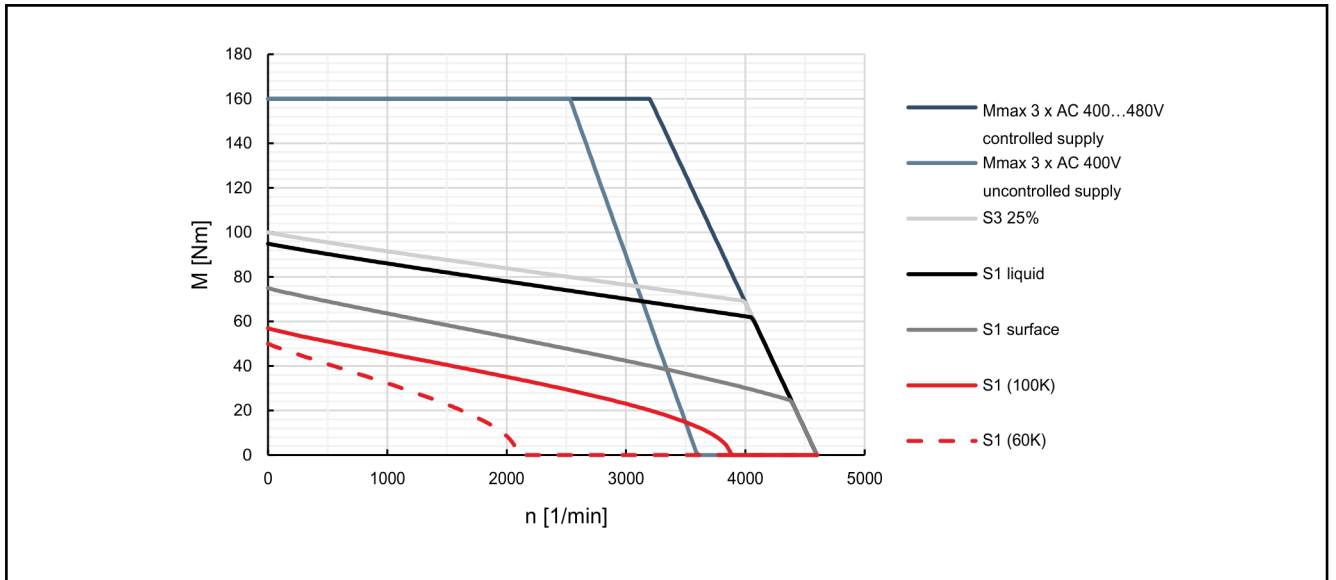

Fig. 4-70: Characteristic curves of motor MSK101D-0300

Technical data

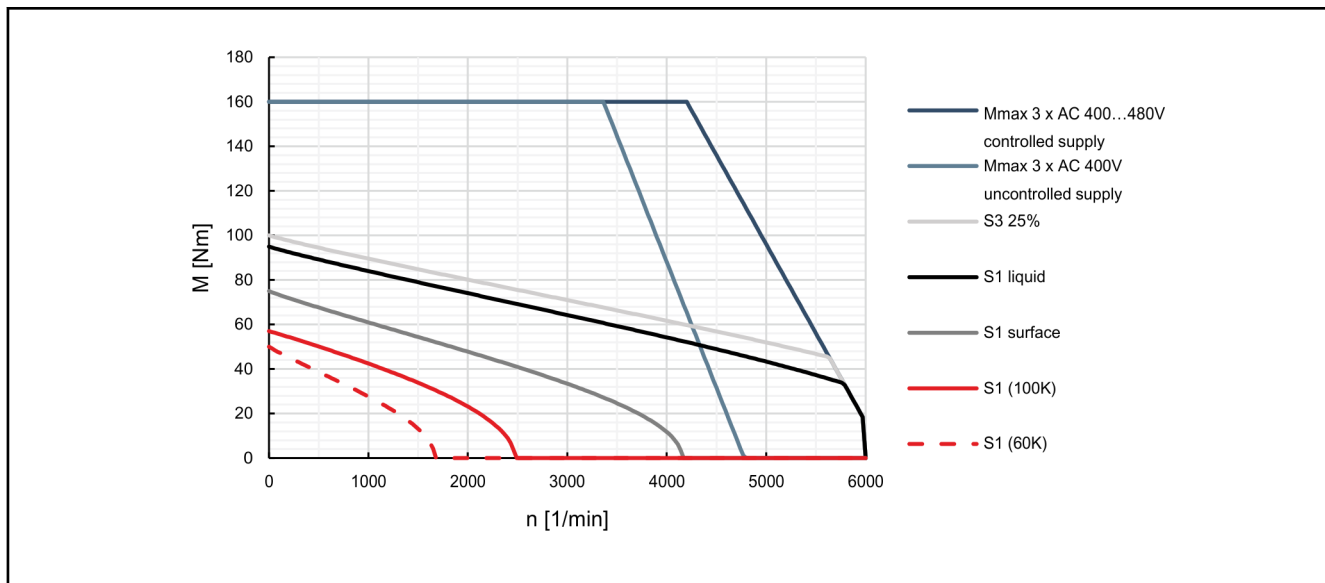

Fig. 4-71: Characteristic curves of motor MSK101D-0450

4.32 MSK101E Technical data

Designation	Symbol	Unit	MSK101E -0200-FN	MSK101E -0200-NN	MSK101E -0300-FN	MSK101E -0300-NN	MSK101E -0450-FN	MSK101E -0450-NN
Continuous torque at standstill 60 K	$M_{0,60}$	Nm	70.0					
Continuous current at standstill 60 K	$I_{0,60(\text{eff})}$	A	32.1		41.6		58.3	
Continuous torque at standstill 100 K	$M_{0,100}$	Nm	80.5					
Continuous current at standstill 100 K	$I_{0,100(\text{eff})}$	A	39.0		47.8		67.6	
Continuous torque at standstill, surface	$M_{0,S}$	Nm	---	105.5	---	105.0	---	105.0
Continuous current at standstill, surface	$I_{0,S(\text{eff})}$	A	---	48.2	---	62.4	---	87.5
Continuous torque at standstill, liquid	$M_{0,L}$	Nm	133.0	---	133.0	---	116.0	---
Continuous current at standstill, liquid	$I_{0,L(\text{eff})}$	A	63.8	---	79.0	---	97.0	---
Maximum torque	M_{max}	Nm	231.0					
Maximum current	$I_{\text{max}(\text{eff})}$	A	144.5		187.4		262.4	
Torque constant at 20 °C	$K_{M,N}$	Nm/A	2.40		1.85		1.32	
Voltage constant at 20 °C ¹⁾	$K_{EMK,1000}$	V/1000 min ⁻¹	148.0		113.8		81.2	
Winding resistance at 20 °C	R_{12}	Ohm	0.18		0.11		0.06	
Winding inductance	L_{12}	mH	3.3		1.96		1.08	
Leakage capacitance of the component	C_{dis}	nF	15.2		16.7			
Number of pole pairs	p	-	4					
Moment of inertia of rotor	J_{red}	kg*m ²	0.01380					
Thermal time constant	$T_{\text{th,nom}}$	min	5.0	100.0	5.0	100.0	5.0	100.0
Maximum speed (electric)	$n_{\text{max el}}$	min ⁻¹	4500		4600		6000	
Sound pressure level	L_P	dB[A]	< 75					
Mass ²⁾	m	kg	53.5 (57.3) (59.7)					
Ambient temperature during operation	T_{amb}	°C	0 ... 40					
Protection class (EN 60034-5)	-	-	IP65					
Thermal class (EN 60034-1)	T.CL.	-	155					
Data liquid cooling								
Heat loss to be dissipated	P_V	kW	1.50	---	1.50	---	1.50	---
Inlet temperature coolant	T_{in}	°C	10 ... 40	---	10 ... 40	---	10 ... 40	---
Permissible coolant temperature increase at P_V	ΔT_{max}	K	10	---	10	---	10	---
Required coolant flow rate at P_V	Q_{min}	l/min	2.2	---	2.2	---	2.2	---
Pressure drop at Q_{min}	Δp	bar	0.8	---	0.8	---	0.8	---
Maximum permissible inlet pressure	p_{max}	bar	6.0	---	6.0	---	6.0	---
Volume of coolant duct	V_{cool}	l	0.14	---	0.14	---	0.14	---
Material of coolant duct			Die-cast aluminum					

Last amended: 2014-01-21

1) Manufacturing tolerance ±5%
 2) (...) Motors with holding brake 1, 2, ...
 Tab. 4-31: MSK - Technical data

Technical data

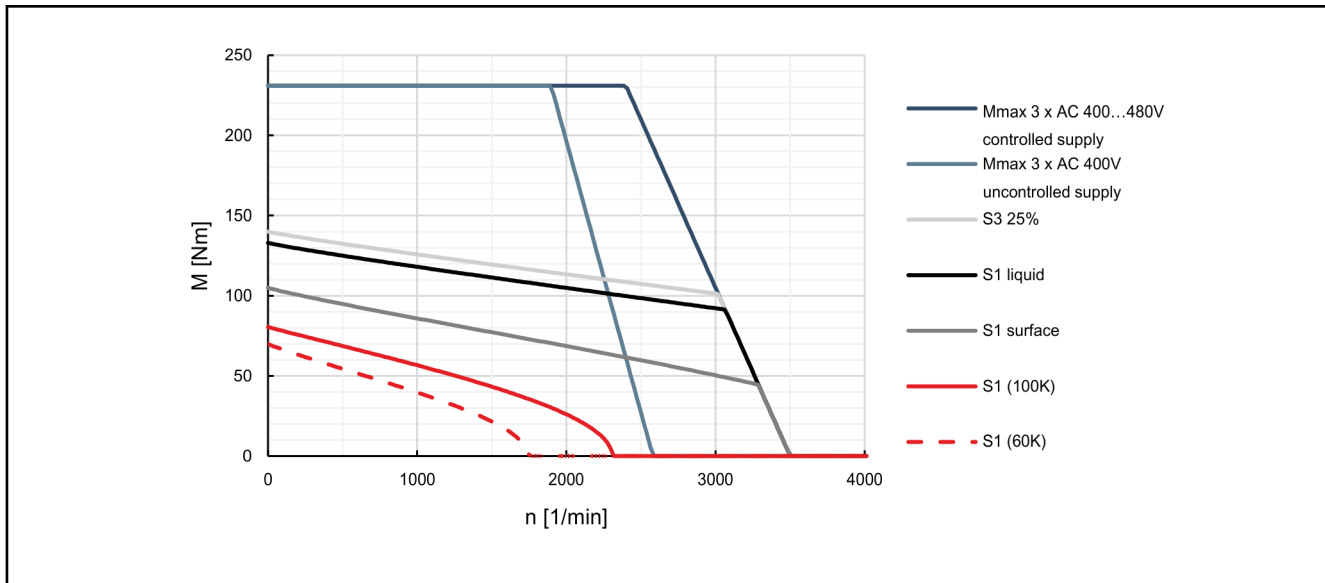

Fig. 4-72: Characteristic curves of motor MSK101E-0200

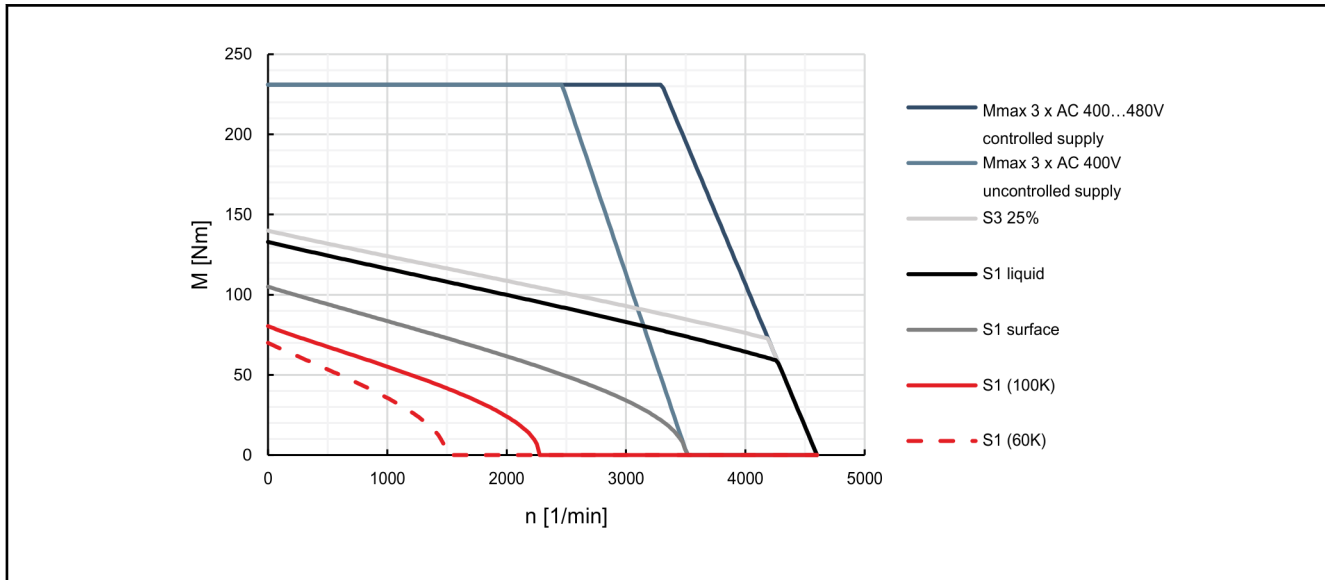

Fig. 4-73: Characteristic curves of motor MSK101E-0300

Technical data

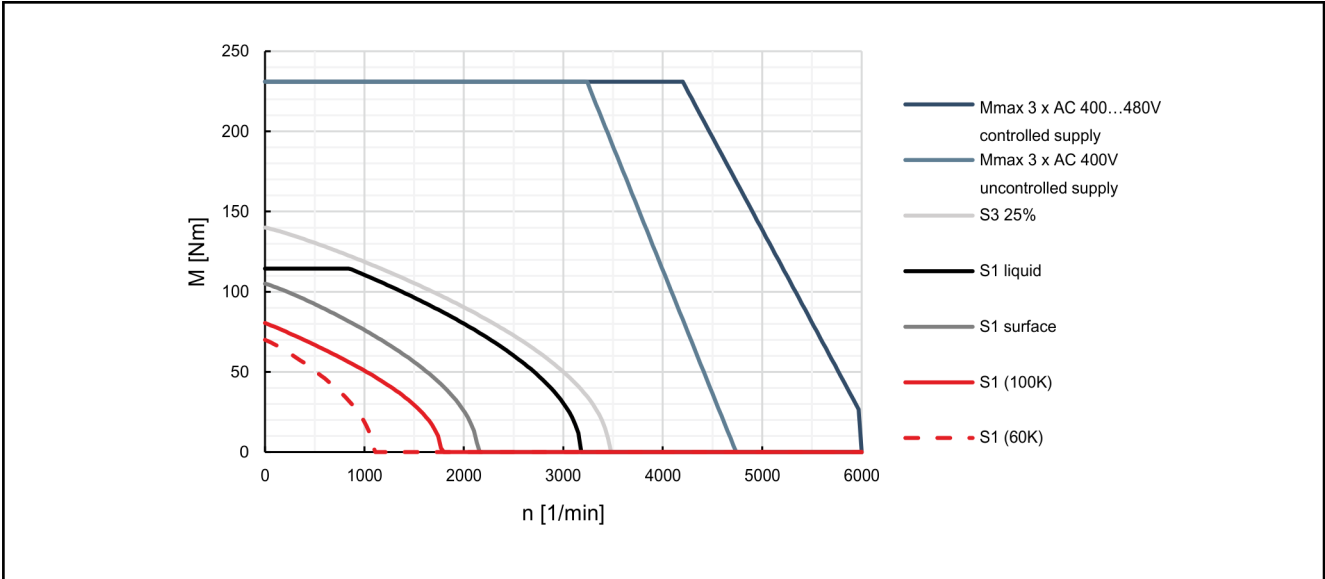

Fig. 4-74: Characteristic curves of motor MSK101E-0450

Technical data

4.33 MSK103A Technical data

Designation	Symbol	Unit	MSK103A-0300-NN
Continuous torque at standstill 60 K	M_{0_60}	Nm	21.0
Continuous current at standstill 60 K	$I_{0_60(\text{eff})}$	A	12.5
Continuous torque at standstill 100 K	M_{0_100}	Nm	24.0
Continuous current at standstill 100 K	$I_{0_100(\text{eff})}$	A	14.3
Maximum torque	M_{max}	Nm	51.0
Maximum current	$I_{\text{max}(\text{eff})}$	A	40.0
Torque constant at 20 °C	K_{M_N}	Nm/A	1.74
Voltage constant at 20 °C ¹⁾	K_{EMK_1000}	V/1000 min ⁻¹	111.0
Winding resistance at 20 °C	R_{12}	Ohm	0.59
Winding inductance	L_{12}	mH	12.8
Leakage capacitance of the component	C_{dis}	nF	1.5
Number of pole pairs	p	-	4
Moment of inertia of rotor	J_{red}	kg*m ²	0.00442
Thermal time constant	$T_{\text{th_nom}}$	min	25.0
Maximum speed (electric)	$n_{\text{max el}}$	min ⁻¹	4800
Sound pressure level	L_p	dB[A]	< 75
Mass	m	kg	18.0
Ambient temperature during operation	T_{amb}	°C	0 ... 40
Protection class (EN 60034-5)	-	-	IP65
Thermal class (EN 60034-1)	T.CL.	-	155

Last amended: 2014-05-05

1) Manufacturing tolerance $\pm 5\%$
 Tab. 4-32: MSK - Technical data

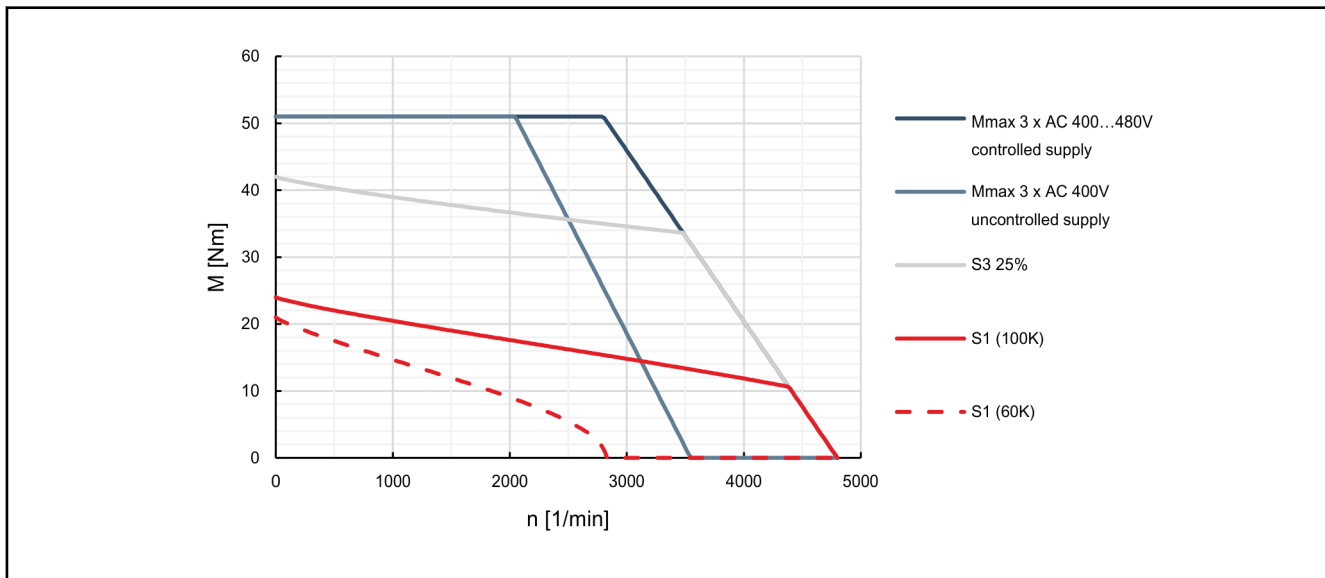

Fig. 4-75: Characteristic curves of motor MSK103A-0300

4.34 MSK103B Technical data

Designation	Symbol	Unit	MSK103B-0300-NN
Continuous torque at standstill 60 K	M_{0_60}	Nm	28.0
Continuous current at standstill 60 K	$I_{0_60(\text{eff})}$	A	17.0
Continuous torque at standstill 100 K	M_{0_100}	Nm	31.0
Continuous current at standstill 100 K	$I_{0_100(\text{eff})}$	A	19.0
Maximum torque	M_{max}	Nm	85.0
Maximum current	$I_{\text{max}(\text{eff})}$	A	63.0
Torque constant at 20 °C	K_{M_N}	Nm/A	1.76
Voltage constant at 20 °C ¹⁾	$K_{\text{EMK_1000}}$	V/1000 min ⁻¹	108.0
Winding resistance at 20 °C	R_{12}	Ohm	0.36
Winding inductance	L_{12}	mH	8.0
Leakage capacitance of the component	C_{dis}	nF	2.1
Number of pole pairs	p	-	4
Moment of inertia of rotor	J_{red}	kg*m ²	0.00594
Thermal time constant	$T_{\text{th_nom}}$	min	27.0
Maximum speed (electric)	$n_{\text{max el}}$	min ⁻¹	4700
Sound pressure level	L_P	dB[A]	< 75
Mass ²⁾	m	kg	22.5 (26.0)
Ambient temperature during operation	T_{amb}	°C	0 ... 40
Protection class (EN 60034-5)	-	-	IP65
Thermal class (EN 60034-1)	T.CL.	-	155

Last amended: 2014-05-05

- 1) Manufacturing tolerance ±5%
 2) (...) Motors with holding brake 1
 Tab. 4-33: MSK - Technical data

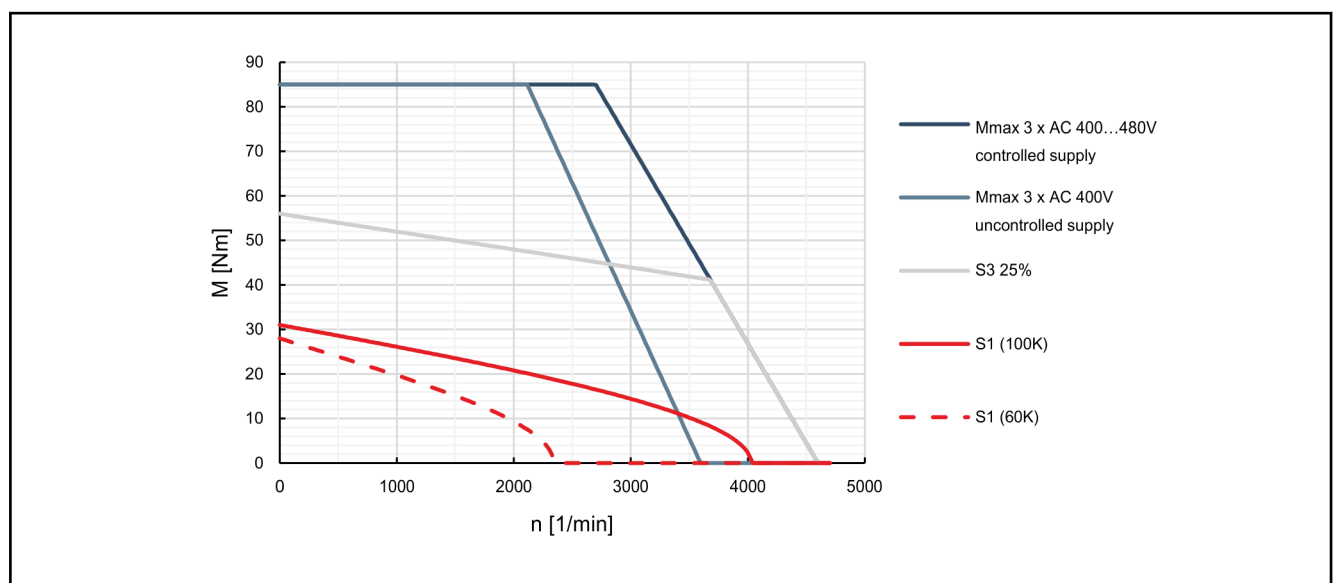

Fig. 4-76: Characteristic curves of motor MSK103B-0300

Technical data

4.35 MSK103D Technical data

Designation	Symbol	Unit	MSK103D-0300-NN
Continuous torque at standstill 60 K	M_{0_60}	Nm	46.0
Continuous current at standstill 60 K	$I_{0_60(\text{eff})}$	A	26.3
Continuous torque at standstill 100 K	M_{0_100}	Nm	53.0
Continuous current at standstill 100 K	$I_{0_100(\text{eff})}$	A	30.8
Maximum torque	M_{max}	Nm	138.0
Maximum current	$I_{\text{max}(\text{eff})}$	A	94.7
Torque constant at 20 °C	K_{M_N}	Nm/A	1.84
Voltage constant at 20 °C ¹⁾	K_{EMK_1000}	V/1000 min ⁻¹	113.0
Winding resistance at 20 °C	R_{12}	Ohm	0.2
Winding inductance	L_{12}	mH	4.87
Leakage capacitance of the component	C_{dis}	nF	6.0
Number of pole pairs	p	-	4
Moment of inertia of rotor	J_{red}	kg*m ²	0.00894
Thermal time constant	$T_{\text{th_nom}}$	min	36.0
Maximum speed (electric)	$n_{\text{max el}}$	min ⁻¹	4600
Sound pressure level	L_p	dB[A]	< 75
Mass ²⁾	m	kg	31.6 (36.1)
Ambient temperature during operation	T_{amb}	°C	0 ... 40
Protection class (EN 60034-5)	-	-	IP65
Thermal class (EN 60034-1)	T.CL.	-	155

Last amended: 2014-05-05

- 1) Manufacturing tolerance $\pm 5\%$
 2) (...) Motors with holding brake 2
 Tab. 4-34: MSK - Technical data

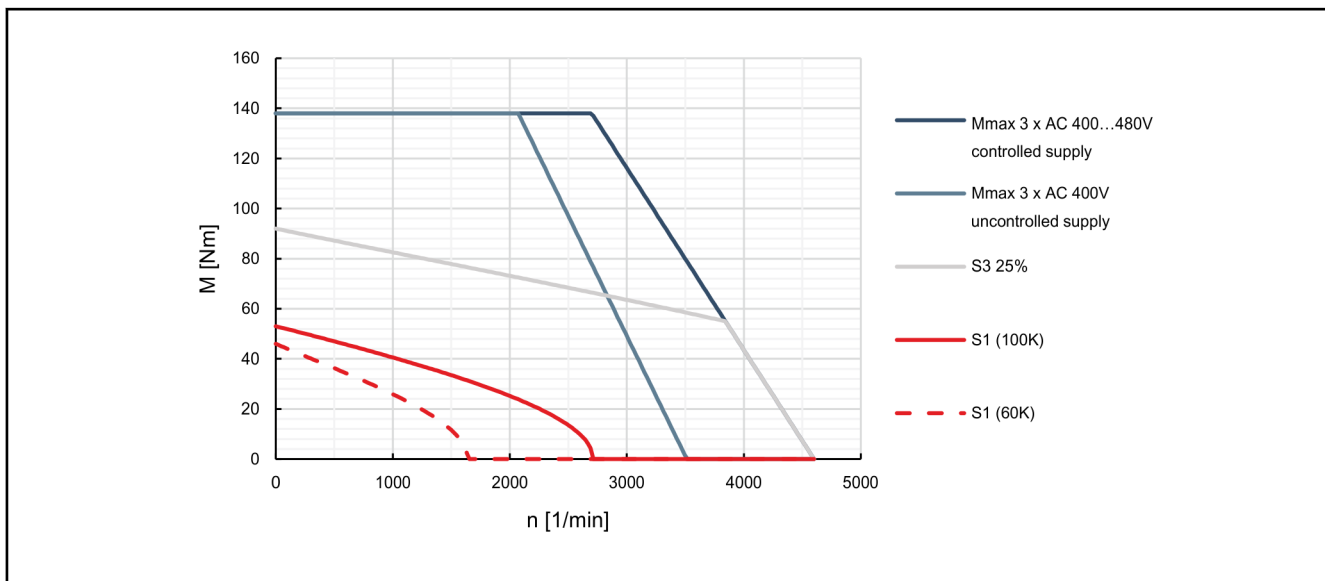

Fig. 4-77: Characteristic curves of motor MSK103D-0300

4.36 MSK131B Technical data

Designation	Symbol	Unit	MSK131B-0200-NN
Continuous torque at standstill 60 K	M_{0_60}	Nm	85.0
Continuous current at standstill 60 K	$I_{0_60(\text{eff})}$	A	36.7
Continuous torque at standstill 100 K	M_{0_100}	Nm	---
Continuous current at standstill 100 K	$I_{0_100(\text{eff})}$	A	---
Continuous torque at standstill, surface	M_{0_S}	Nm	127.5
Continuous current at standstill, surface	$I_{0_S(\text{eff})}$	A	55.1
Maximum torque	M_{max}	Nm	250.0
Maximum current	$I_{\text{max}(\text{eff})}$	A	165.0
Torque constant at 20 °C	K_{M_N}	Nm/A	2.55
Voltage constant at 20 °C ¹⁾	$K_{\text{EMK_1000}}$	V/1000 min ⁻¹	155.0
Winding resistance at 20 °C	R_{12}	Ohm	0.16
Winding inductance	L_{12}	mH	5.3
Leakage capacitance of the component	C_{dis}	nF	14.3
Number of pole pairs	p	-	4
Moment of inertia of rotor	J_{red}	kg*m ²	0.02320
Thermal time constant	$T_{\text{th_nom}}$	min	50.0
Maximum speed (electric)	$n_{\text{max el}}$	min ⁻¹	3,200
Sound pressure level	L_p	dB[A]	< 75
Mass ²⁾	m	kg	84.0 (89.4)
Ambient temperature during operation	T_{amb}	°C	0 ... 40
Protection class (EN 60034-5)	-	-	IP65
Thermal class (EN 60034-1)	T.CL.	-	155

Last amended: 2014-01-21

- 1) Manufacturing tolerance ±5%
 2) (...) Motors with holding brake 1, 2, ...
 Tab. 4-35: MSK - Technical data

Technical data

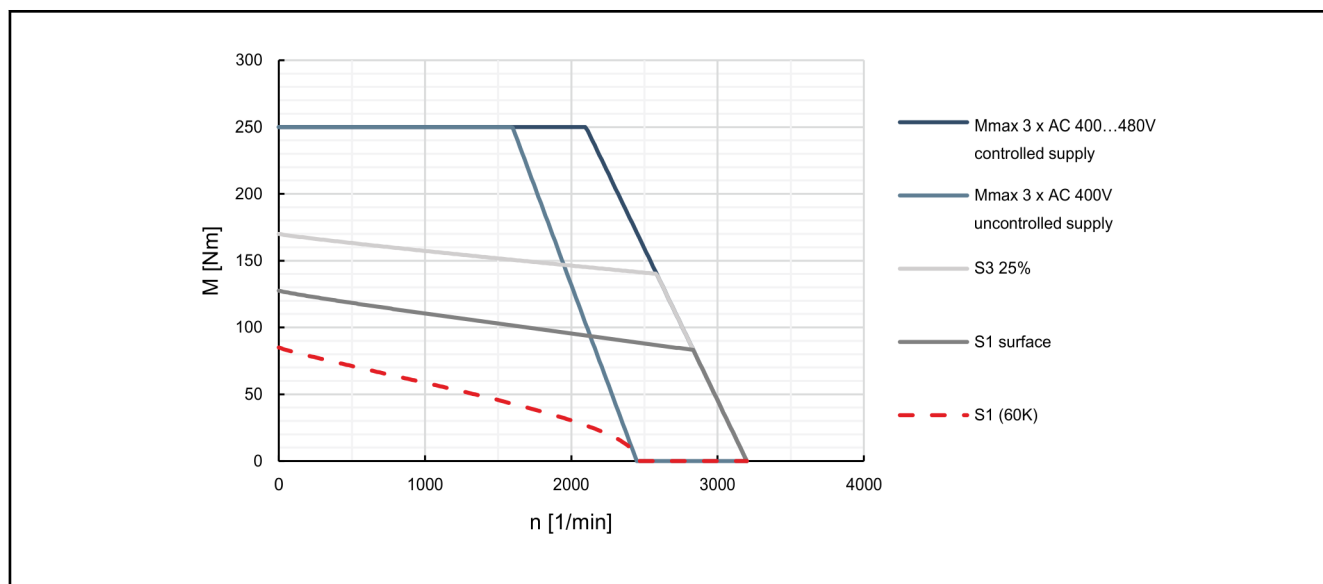

Fig. 4-78: Characteristic curves of motor MSK131B-0200

4.37 MSK131D Technical data

Designation	Symbol	Unit	MSK131D-0200-NN
Continuous torque at standstill 60 K	M_{0_60}	Nm	160.0
Continuous current at standstill 60 K	$I_{0_60(\text{eff})}$	A	65.2
Continuous torque at standstill 100 K	M_{0_100}	Nm	---
Continuous current at standstill 100 K	$I_{0_100(\text{eff})}$	A	---
Continuous torque at standstill, surface	M_{0_S}	Nm	240.0
Continuous current at standstill, surface	$I_{0_S(\text{eff})}$	A	97.8
Maximum torque	M_{max}	Nm	495.0
Maximum current	$I_{\text{max}(\text{eff})}$	A	293.4
Torque constant at 20 °C	K_{M_N}	Nm/A	2.70
Voltage constant at 20 °C ¹⁾	$K_{\text{EMK_1000}}$	V/1000 min ⁻¹	170.0
Winding resistance at 20 °C	R_{12}	Ohm	0.071
Winding inductance	L_{12}	mH	3.0
Leakage capacitance of the component	C_{dis}	nF	27.7
Number of pole pairs	p	-	4
Moment of inertia of rotor	J_{red}	kg*m ²	0.03820
Thermal time constant	$T_{\text{th_nom}}$	min	64.0
Maximum speed (electric)	$n_{\text{max el}}$	min ⁻¹	3000
Sound pressure level	L_p	dB[A]	< 75
Mass ²⁾	m	kg	116.0 (121.4) (128.0)
Ambient temperature during operation	T_{amb}	°C	0 ... 40
Protection class (EN 60034-5)	-	-	IP65
Thermal class (EN 60034-1)	T.CL.	-	155

Last amended: 2014-03-12

- 1) Manufacturing tolerance ±5%
 2) (...) Motors with holding brake 1, 2, ...
 Tab. 4-36: MSK - Technical data

Technical data

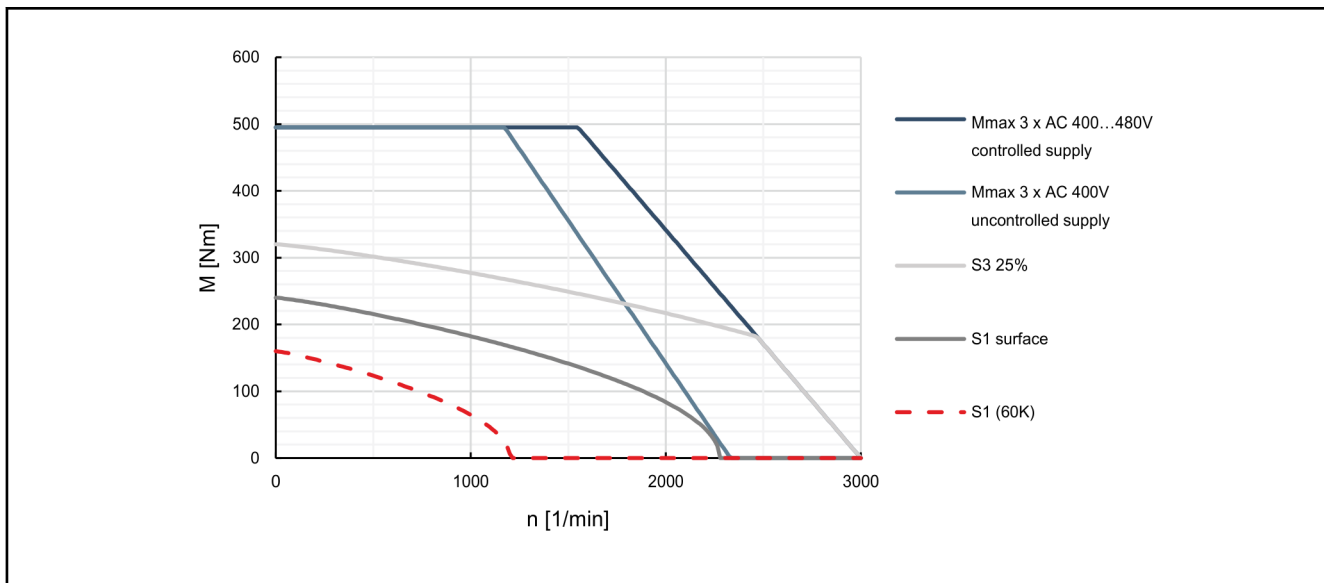

Fig. 4-79: Characteristic curves of motor MSK131D-0200

4.38 MSK133B Technical data

Data sheet

Designation	Symbol	Unit	MSK133B-0202-SA	MSK133B-0203-FN
Continuous torque at standstill, surface	$M_{0,S}$	Nm	152.0	---
Continuous current at standstill, surface	$I_{0,S(eff)}$	A	63.0	---
Continuous torque at standstill, liquid	$M_{0,L}$	Nm	---	162.0
Continuous current at standstill, liquid	$I_{0,L(eff)}$	A	---	69.4
Maximum torque	M_{max}	Nm	320.0	300.0
Maximum current	$I_{max(eff)}$	A	160.0	
Torque constant at 20 °C	$K_{M,N}$	Nm/A	2.34	
Voltage constant at 20 °C ¹⁾	$K_{EMK,1000}$	V/1000 min ⁻¹	155.2	
Winding resistance at 20 °C	R_{12}	Ohm	0.153	
Winding inductance	L_{12}	mH	10.5	9.5
Leakage capacitance of the component	C_{dis}	nF	14.4	10.7
Number of pole pairs	p	-	3	
Moment of inertia of rotor	J_{red}	kg*m ²	0.04760	
Thermal time constant	$T_{th,nom}$	min	16.6	8.0
Maximum speed (electric)	n_{max}	min ⁻¹	3300	
Sound pressure level	L_P	dB[A]	< 78	
Mass	m	kg	91.6	
Ambient temperature during operation	T_{amb}	°C	0 ... 40	
Protection class (EN 60034-5)	-	-	IP65	
Temperature class (EN 60034-1)	T.CL.	-	155	
Data liquid cooling				
Heat loss to be dissipated	P_V	kW	---	2.10
Inlet temperature coolant	T_{in}	°C	---	10..40
Permissible coolant temperature increase at P_V	ΔT_{max}	K	---	8
Required coolant flow rate at P_V	Q_{min}	l/min	---	4.0
Pressure drop at Q_{min}	Δp	bar	---	< 0.6
Maximum permissible inlet pressure	p_{max}	bar	---	6.0
Volume of coolant duct	V_{cool}	l	---	0.15
Material of coolant duct			---	Stainless steel

Last amended: 2013-11-20

1) Manufacturing tolerance $\pm 5\%$
Tab. 4-37: MSK - Technical data

Technical data

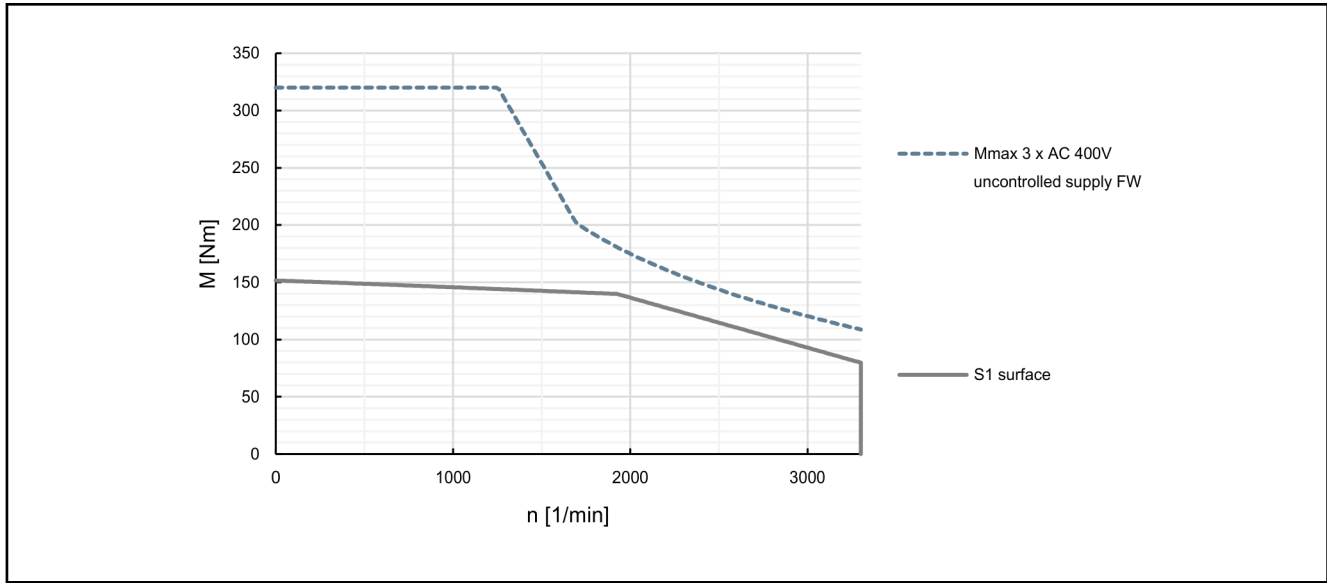

Fig. 4-80: Characteristic curves of motor MSK133B-0202-SA, uncontrolled supply 3 x AC 400 V (-5%) with reluctance characteristic curve and field weakening

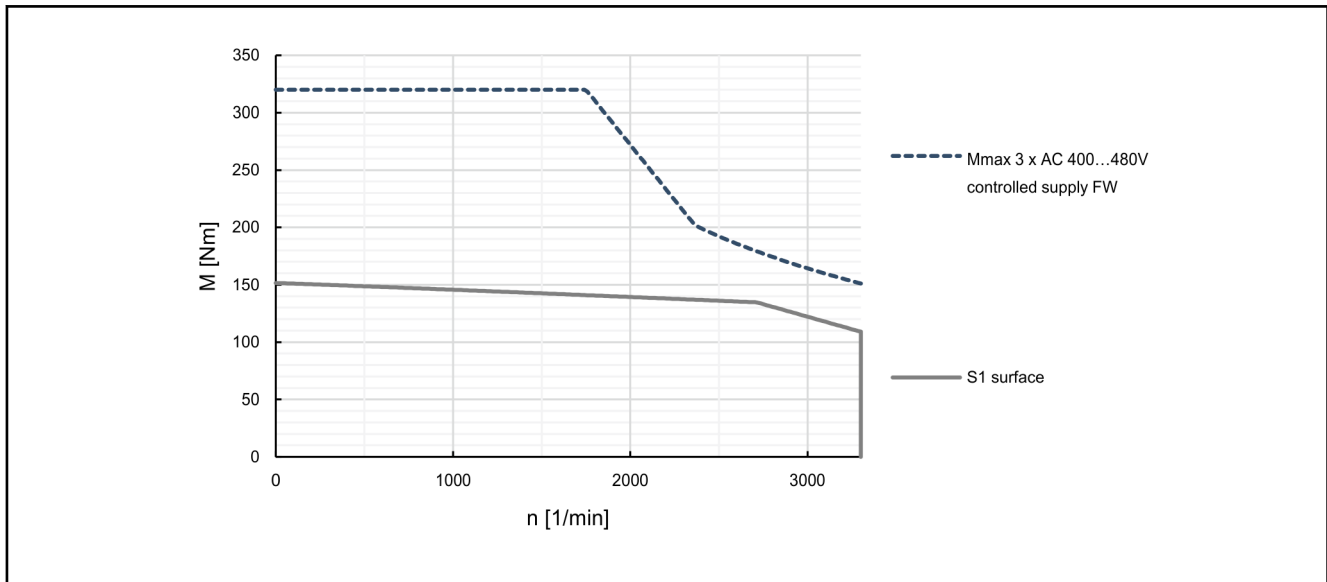

Fig. 4-81: Characteristic curves of motor MSK133B-0202-SA, controlled supply 3 x AC 400 V (-5%) with reluctance characteristic curve and field weakening

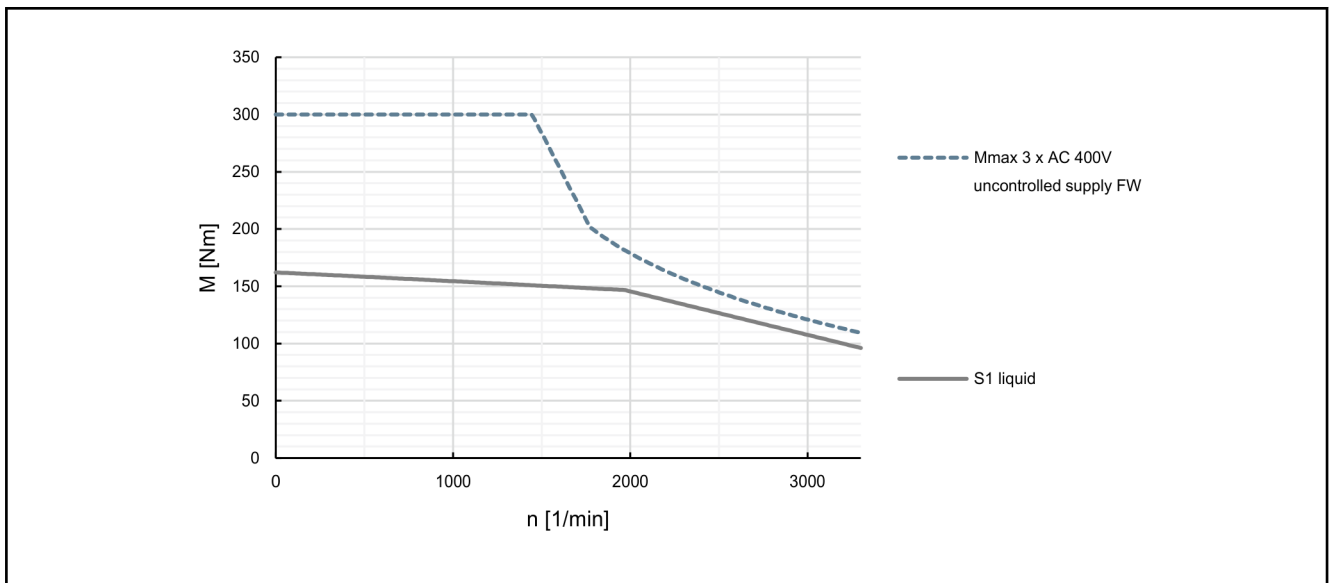

Fig. 4-82: Characteristic curves of motor MSK133B-0203-FN, uncontrolled supply 3 × AC 400 V (-5%) with reluctance characteristic curve and field weakening

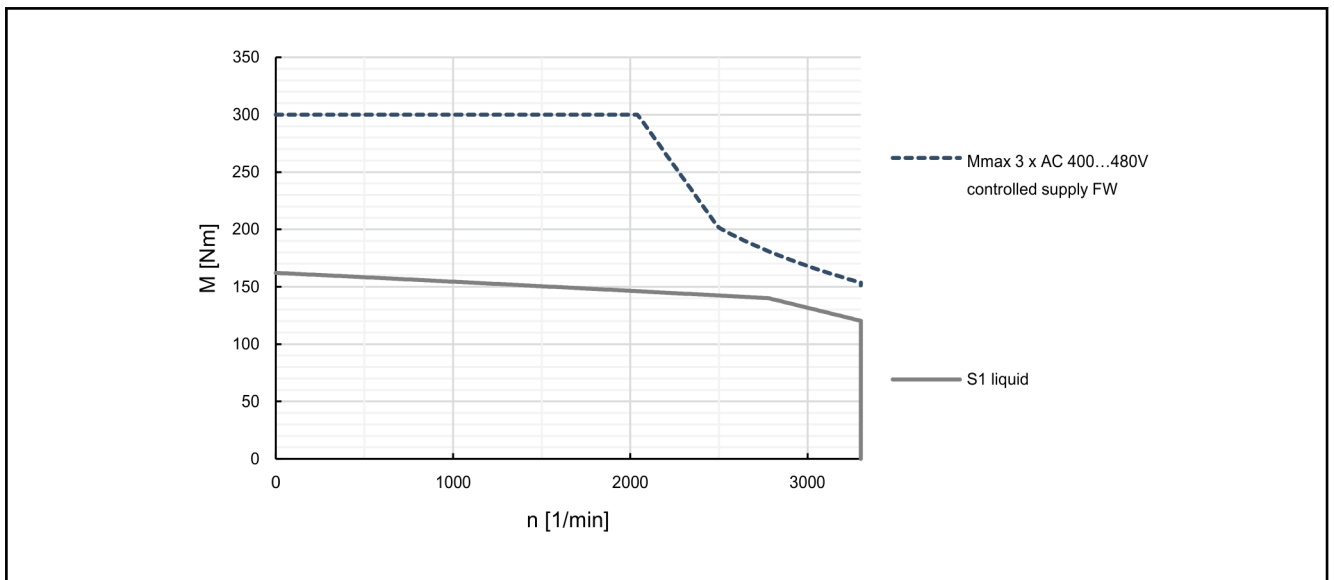

Fig. 4-83: Characteristic curves of motor MSK133B-0203-FN, controlled supply 3 × AC 400 V (-5%) with reluctance characteristic curve and field weakening

Technical data

4.39 MSK133C Technical data

Data sheet

Designation	Symbol	Unit	MSK133C-0202-SA	MSK133C-0203-FN
Continuous torque at standstill, surface	$M_{0,S}$	Nm	204.0	---
Continuous current at standstill, surface	$I_{0,S(eff)}$	A	81.0	---
Continuous torque at standstill, liquid	$M_{0,L}$	Nm	---	232.5
Continuous current at standstill, liquid	$I_{0,L(eff)}$	A	---	93.0
Maximum torque	M_{max}	Nm	425.0	400.0
Maximum current	$I_{max(eff)}$	A	205.0	
Torque constant at 20 °C	$K_{M,N}$	Nm/A	2.47	
Voltage constant at 20 °C ¹⁾	$K_{EMK,1000}$	V/1000 min ⁻¹	157.6	
Winding resistance at 20 °C	R_{12}	Ohm	0.103	
Winding inductance	L_{12}	mH	7.8	7
Leakage capacitance of the component	C_{dis}	nF	15.2	
Number of pole pairs	p	-	3	
Moment of inertia of rotor	J_{red}	kg*m ²	0.06800	
Thermal time constant	$T_{th,nom}$	min	16.6	8.0
Maximum speed (electric)	n_{max}	min ⁻¹	3300	
Sound pressure level	L_P	dB[A]	< 78	
Mass	m	kg	111.0	
Ambient temperature during operation	T_{amb}	°C	0 ... 40	
Protection class (EN 60034-5)	-	-	IP65	
Temperature class (EN 60034-1)	T.CL.	-	155	
Data liquid cooling				
Heat loss to be dissipated	P_V	kW	---	2.70
Inlet temperature coolant	T_{in}	°C	---	10...40
Permissible coolant temperature increase at P_V	ΔT_{max}	K	---	8
Required coolant flow rate at P_V	Q_{min}	l/min	---	5.0
Pressure drop at Q_{min}	Δp	bar	---	< 0.75
Maximum permissible inlet pressure	p_{max}	bar	---	6.0
Volume of coolant duct	V_{cool}	l	---	0.18
Material of coolant duct			---	Stainless steel

Last amended: 2013-11-11

1) Manufacturing tolerance $\pm 5\%$
 Tab. 4-38: MSK - Technical data

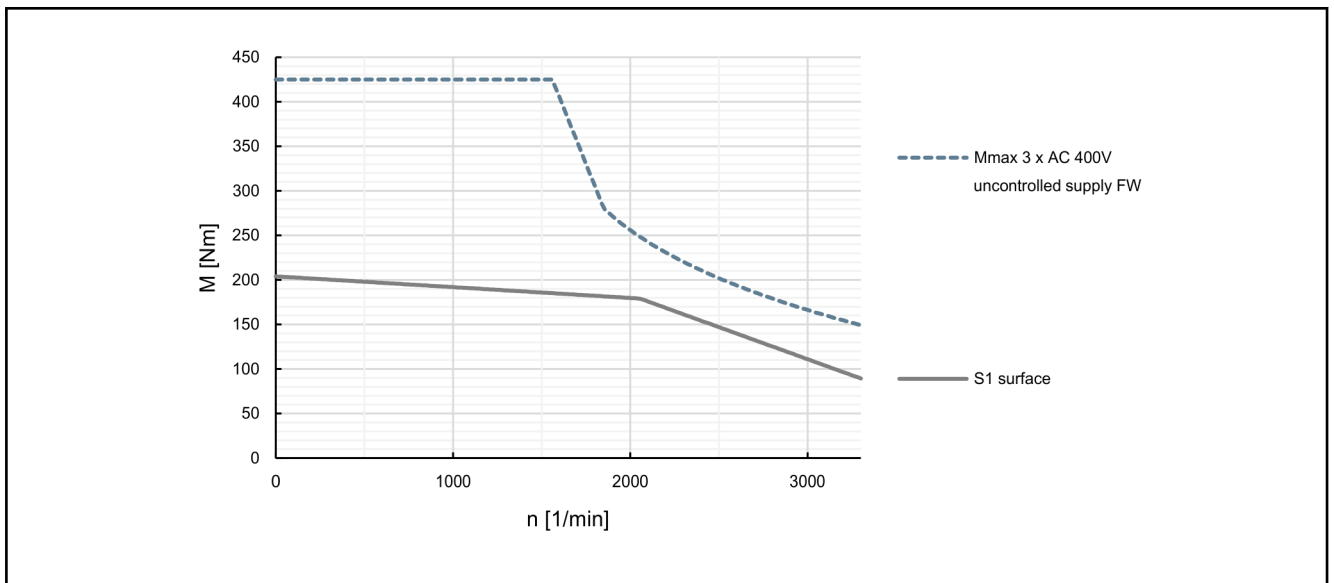

Fig. 4-84: Characteristic curves of motor MSK133C-0202-SA, uncontrolled supply 3 × AC 400 V (-5%) with reluctance characteristic curve and field weakening

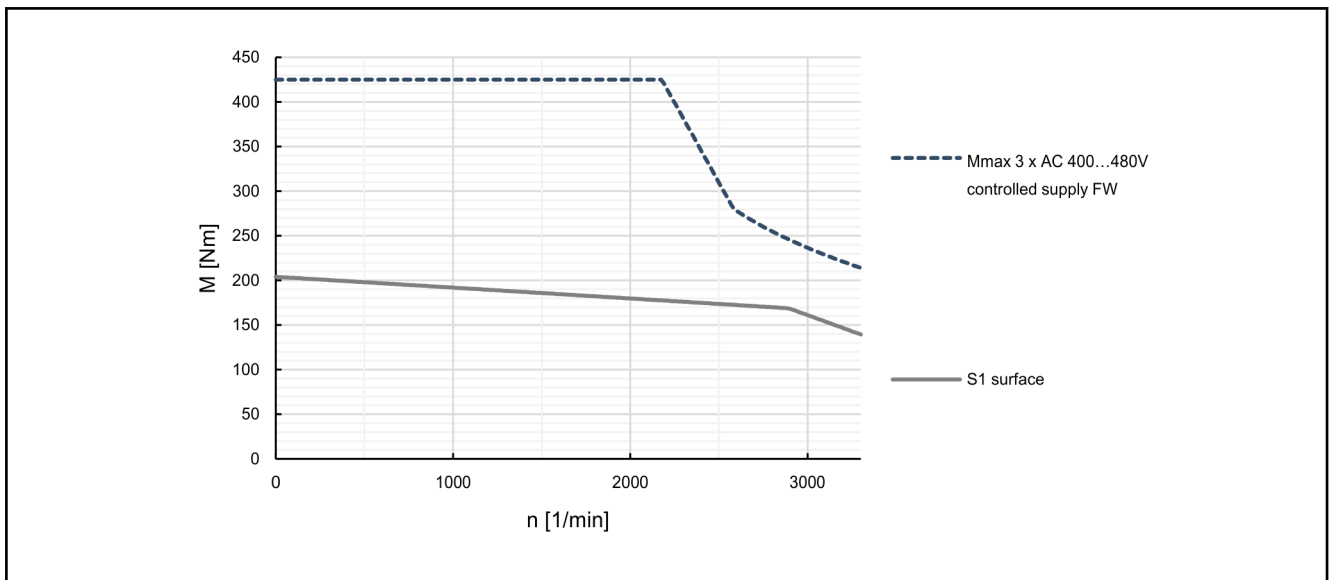

Fig. 4-85: Characteristic curves of motor MSK133C-0202-SA, controlled supply 3 × AC 400 V (-5%) with reluctance characteristic curve and field weakening

Technical data

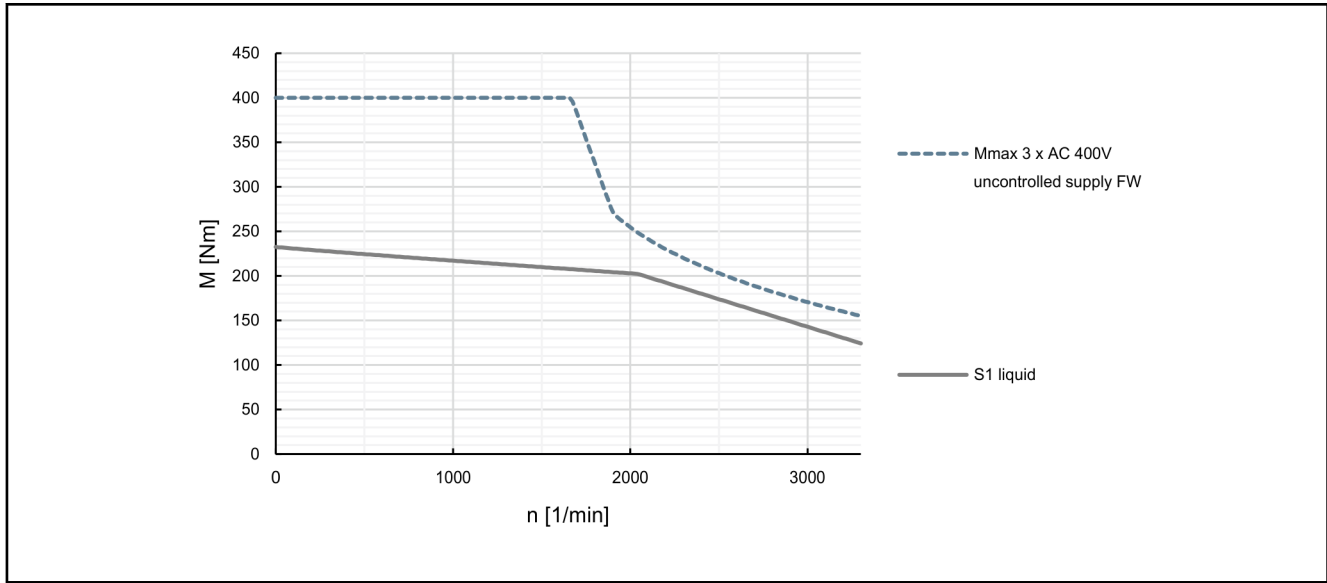

Fig. 4-86: Characteristic curves of motor MSK133C-0203-FN, uncontrolled supply 3 × AC 400 V (-5%) with reluctance characteristic curve and field weakening

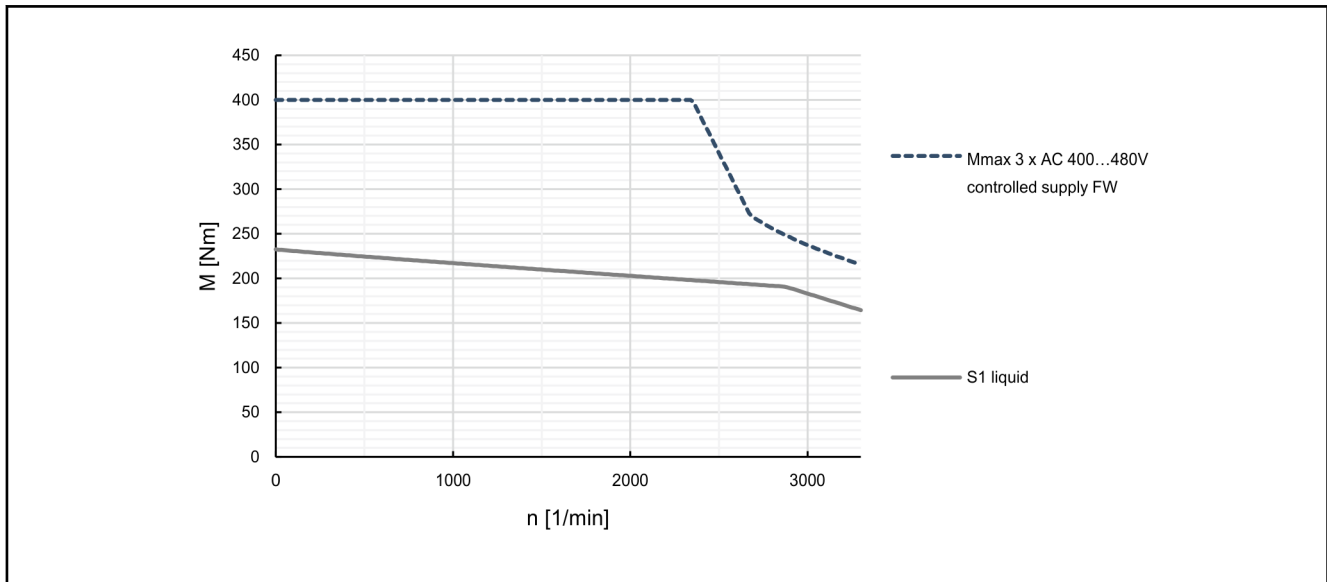

Fig. 4-87: Characteristic curves of motor MSK133C-0203-FN, controlled supply 3 × AC 400 V (-5%) with reluctance characteristic curve and field weakening

4.40 MSK133D Technical data

Designation	Symbol	Unit	MSK133D-0202-SA	MSK133D-0203-FN	MSK133D-0302-SA
Continuous torque at standstill, surface	$M_{0,S}$	Nm	250.0	---	250.0
Continuous current at standstill, surface	$I_{0,S(eff)}$	A	100.0	---	132.0
Continuous torque at standstill, liquid	$M_{0,L}$	Nm	---	290.0	---
Continuous current at standstill, liquid	$I_{0,L(eff)}$	A	---	122.2	---
Maximum torque	M_{max}	Nm	520.0	500.0	520.0
Maximum current	$I_{max(eff)}$	A	265.0		350.0
Torque constant at 20 °C	$K_{M,N}$	Nm/A	2.45		1.86
Voltage constant at 20 °C ¹⁾	$K_{EMK,1000}$	V/1000 min ⁻¹	155.8		118.3
Winding resistance at 20 °C	R_{12}	Ohm	0.075		0.048
Winding inductance	L_{12}	mH	6.1	6	2.9
Leakage capacitance of the component	C_{dis}	nF	16.4	18.4	19.9
Number of pole pairs	p	-	3		
Moment of inertia of rotor	J_{red}	kg*m ²	0.07800		
Thermal time constant	$T_{th,nom}$	min	18.2	8.0	18.2
Maximum speed (electric)	$n_{max,el}$	min ⁻¹	3300		
Sound pressure level	L_P	dB[A]	< 78		
Mass	m	kg	127.0		
Ambient temperature during operation	T_{amb}	°C	0 ... 40		
Protection class (EN 60034-5)	-	-	IP65		
Thermal class (EN 60034-1)	T.CL.	-	155		
Data liquid cooling					
Heat loss to be dissipated	P_V	kW	---	3.10	---
Inlet temperature coolant	T_{in}	°C	---	10...40	---
Permissible coolant temperature increase at P_V	ΔT_{max}	K	---	8	---
Required coolant flow rate at P_V	Q_{min}	l/min	---	6.0	---
Pressure drop at Q_{min}	Δp	bar	---	< 0.9	---
Maximum permissible inlet pressure	p_{max}	bar	---	6.0	---
Volume of coolant duct	V_{cool}	l	---	0.21	---
Material of coolant duct			---	Stainless steel	---

Last amended: 2016-05-06

1) Manufacturing tolerance $\pm 5\%$
Tab. 4-39: MSK - Technical data

Technical data

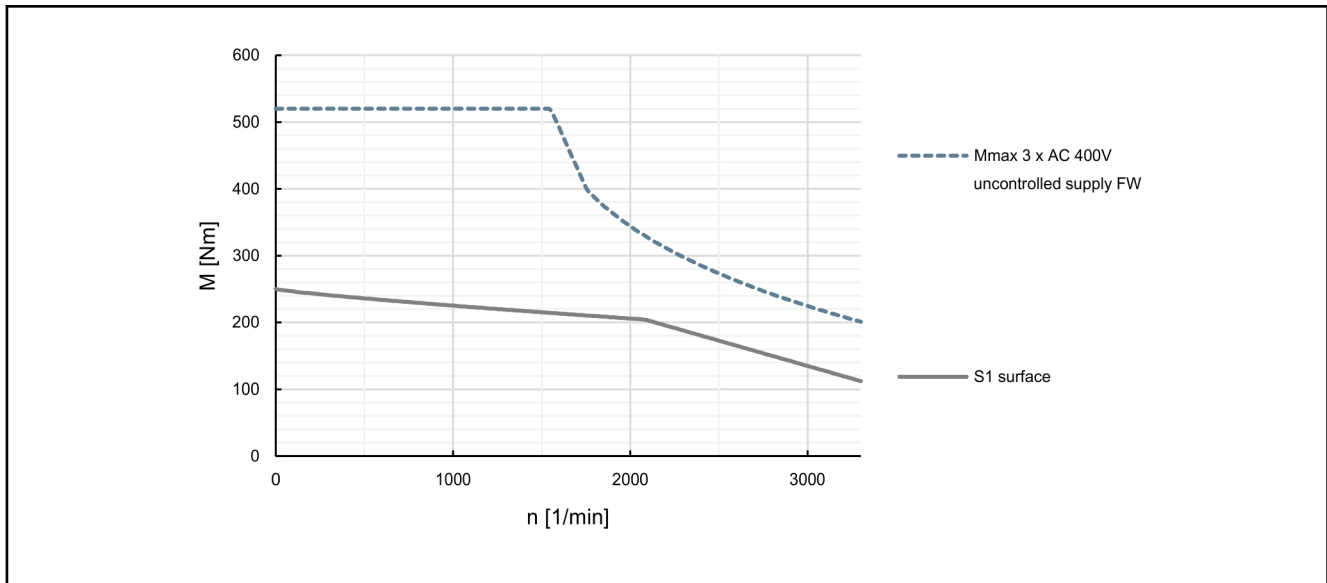

Fig. 4-88: Characteristic curves of motor MSK133D-0202-SA, controlled supply 3 x AC 400 V (-5%) with reluctance characteristic curve and field weakening

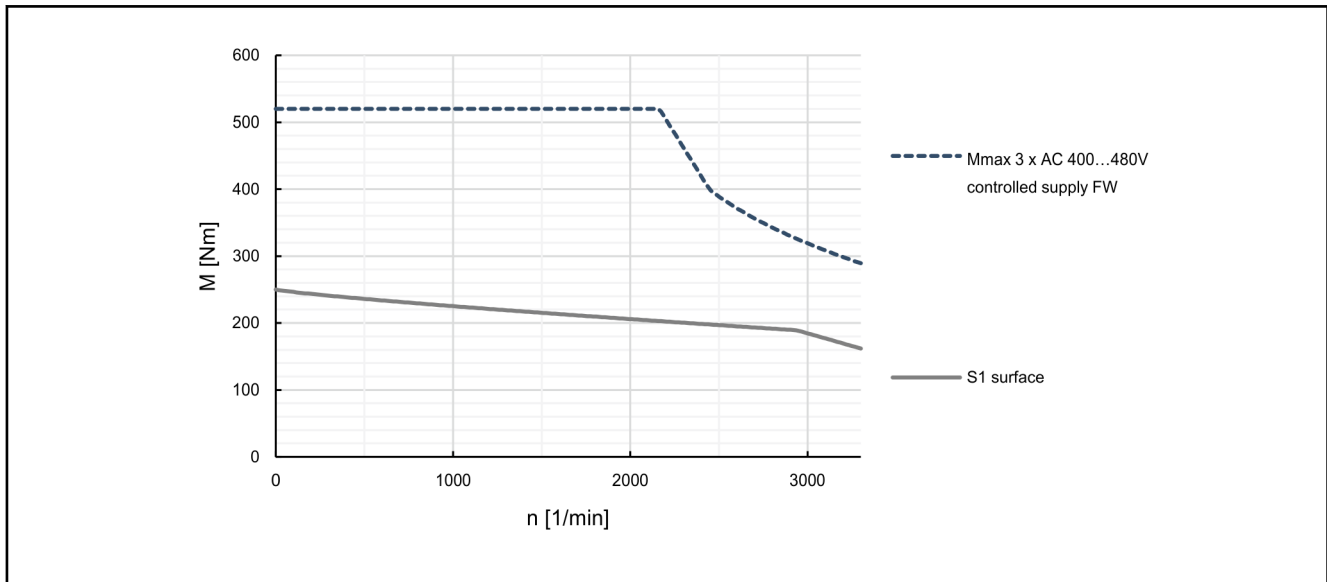

Fig. 4-89: Characteristic curves of motor MSK133D-0202-SA, uncontrolled supply 3 x AC 400 V (-5%) with reluctance characteristic curve and field weakening

Technical data

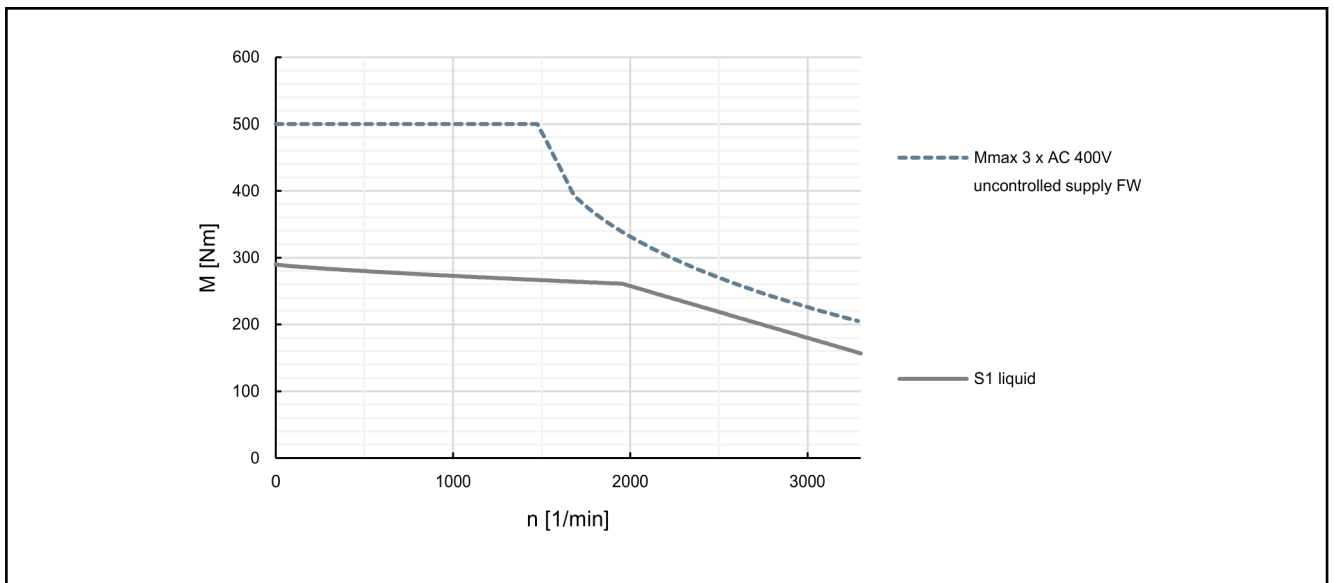

Fig. 4-90: Characteristic curves of motor MSK133D-0203-FN, uncontrolled supply 3 x AC 400 V (-5%) with reluctance characteristic curve and field weakening

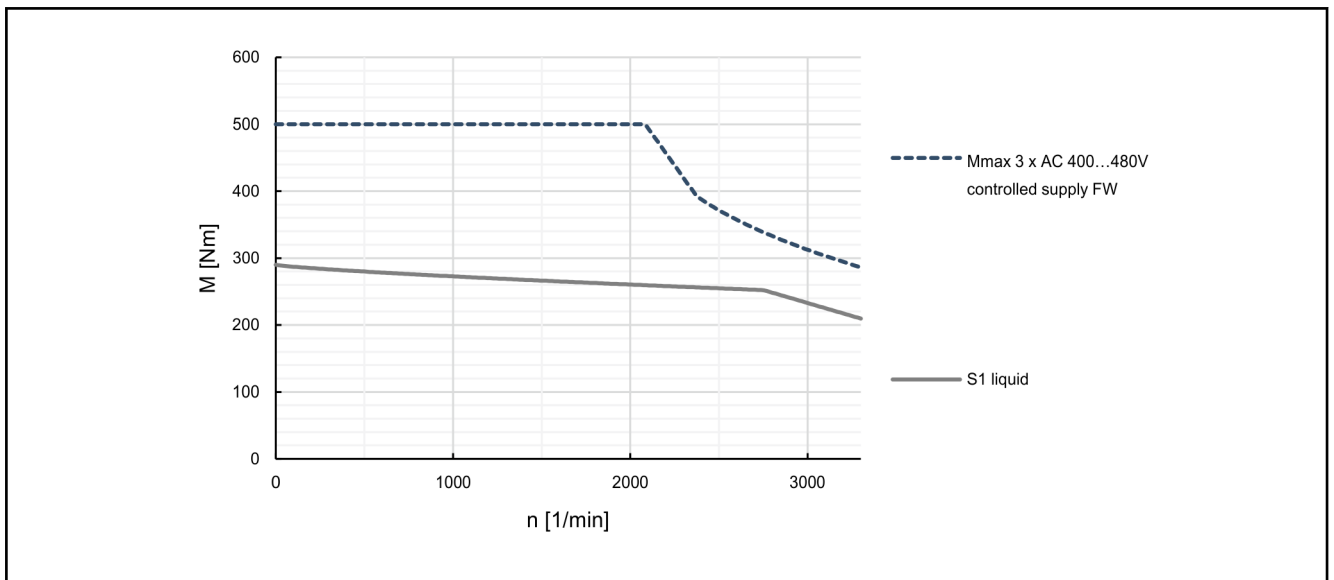

Fig. 4-91: Characteristic curves of motor MSK133D-0203-FN, controlled supply 3 x AC 400 V (-5%) with reluctance characteristic curve and field weakening

Technical data

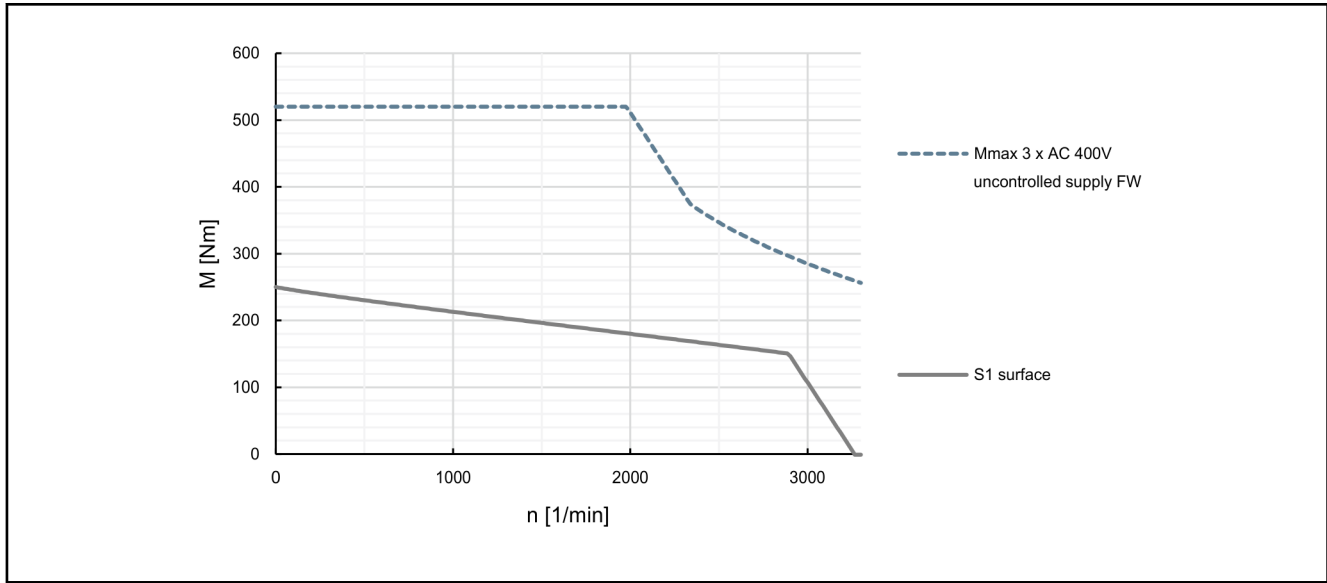

Fig. 4-92: Characteristic curves of motor MSK133D-0302-SA, uncontrolled supply 3 x AC 400 V (-5%) with reluctance characteristic curve and field weakening

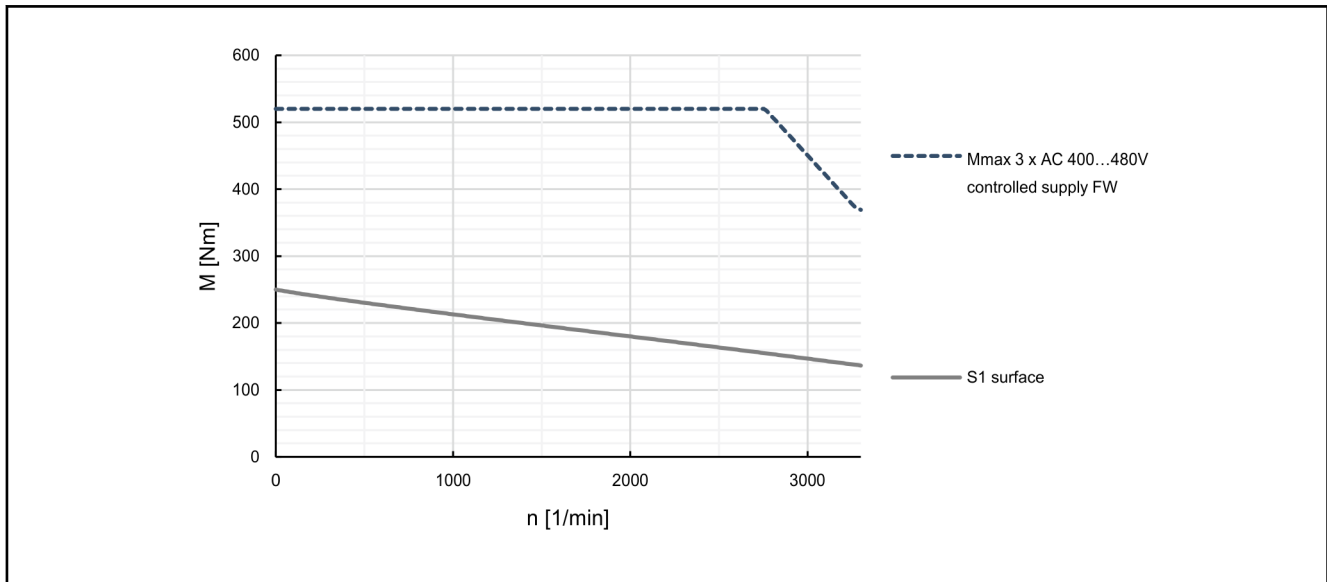

Fig. 4-93: Characteristic curves of motor MSK133D-0302-SA, uncontrolled supply 3 x AC 400 V (-5%) with reluctance characteristic curve and field weakening

4.41 MSK133E Technical data

Data sheet

Designation	Symbol	Unit	MSK133E-0202-SA	MSK133E-0203-FN
Continuous torque at standstill, surface	$M_{0,S}$	Nm	293.0	---
Continuous current at standstill, surface	$I_{0,S(eff)}$	A	115.0	---
Continuous torque at standstill, liquid	$M_{0,L}$	Nm	---	342.0
Continuous current at standstill, liquid	$I_{0,L(eff)}$	A	---	135.5
Maximum torque	M_{max}	Nm	630.7	583.0
Maximum current	$I_{max(eff)}$	A	305.0	
Torque constant at 20 °C	$K_{M,N}$	Nm/A	2.48	
Voltage constant at 20 °C ¹⁾	$K_{EMK,1000}$	V/1000 min ⁻¹	159.8	
Winding resistance at 20 °C	R_{12}	Ohm	0.06	
Winding inductance	L_{12}	mH	5.3	4.8
Leakage capacitance of the component	C_{dis}	nF	24.3	22.6
Number of pole pairs	p	-	3	
Moment of inertia of rotor	J_{red}	kg*m ²	0.09000	
Thermal time constant	$T_{th,nom}$	min	16.0	8.0
Maximum speed (electric)	n_{max}	min ⁻¹	3300	
Sound pressure level	L_P	dB[A]	< 78	
Mass	m	kg	146.0	
Ambient temperature during operation	T_{amb}	°C	0 ... 40	
Protection class acc. to (EN 60034-5)	-	-	IP65	
Temperature class (EN 60034-1)	T.CL.	-	155	
Data liquid cooling				
Heat loss to be dissipated	P_V	kW	---	3.20
Inlet temperature coolant	T_{in}	°C	---	10..40
Permissible coolant temperature increase at P_V	ΔT_{max}	K	---	8
Required coolant flow rate at P_V	Q_{min}	l/min	---	6.0
Pressure drop at Q_{min}	Δp	bar	---	< 1.0
Maximum permissible inlet pressure	p_{max}	bar	---	6.0
Volume of coolant duct	V_{cool}	l	---	0.24
Material of coolant duct			---	Stainless steel

Last amended: 2013-11-11

1) Manufacturing tolerance $\pm 5\%$
Tab. 4-40: MSK - Technical data

Technical data

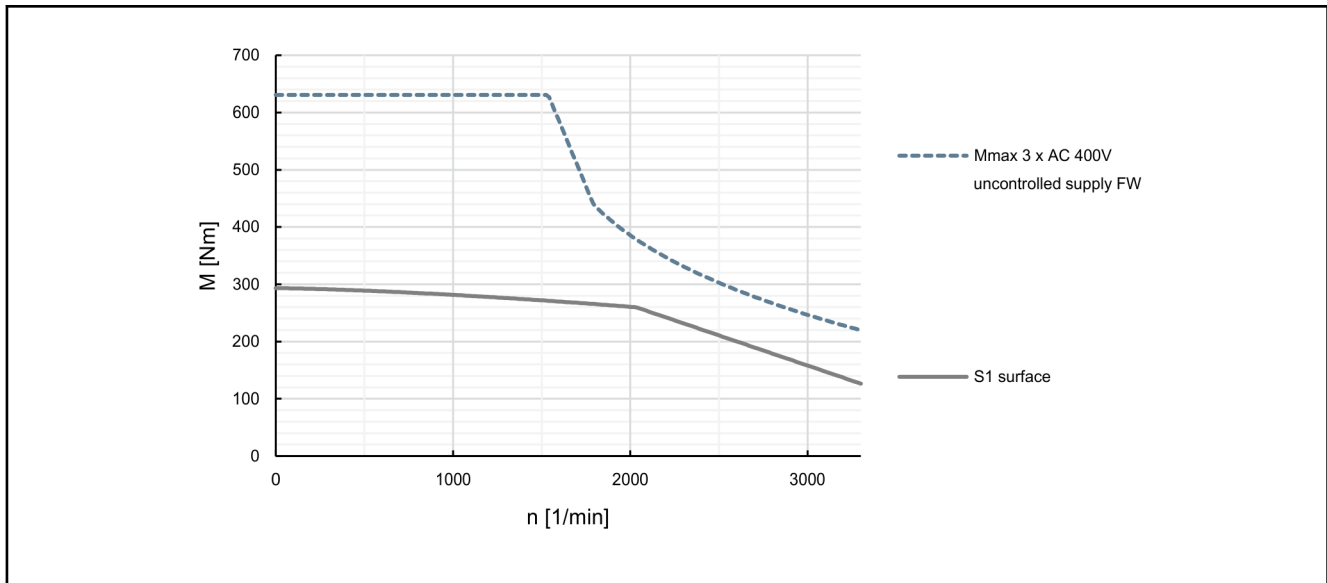

Fig. 4-94: Characteristic curves of motor MSK133E-0202-SA, uncontrolled supply 3 x AC 400 V (-5%) with reluctance characteristic curve and field weakening

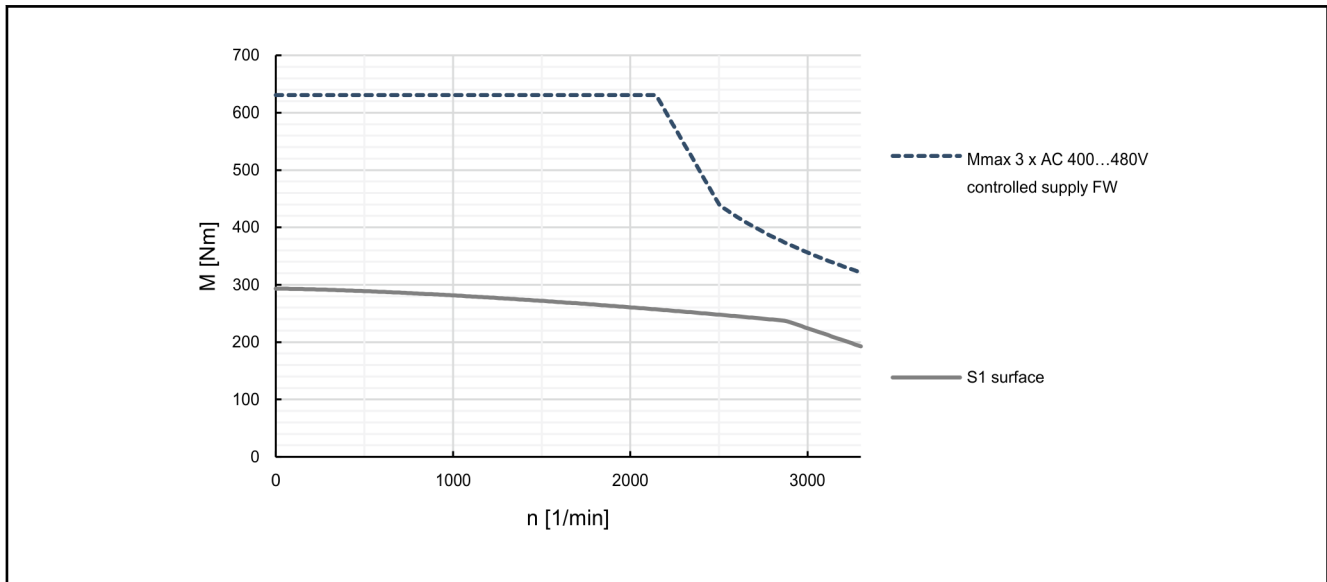

Fig. 4-95: Characteristic curves of motor MSK133E-0202-SA, controlled supply 3 x AC 400 V (-5%) with reluctance characteristic curve and field weakening

Technical data

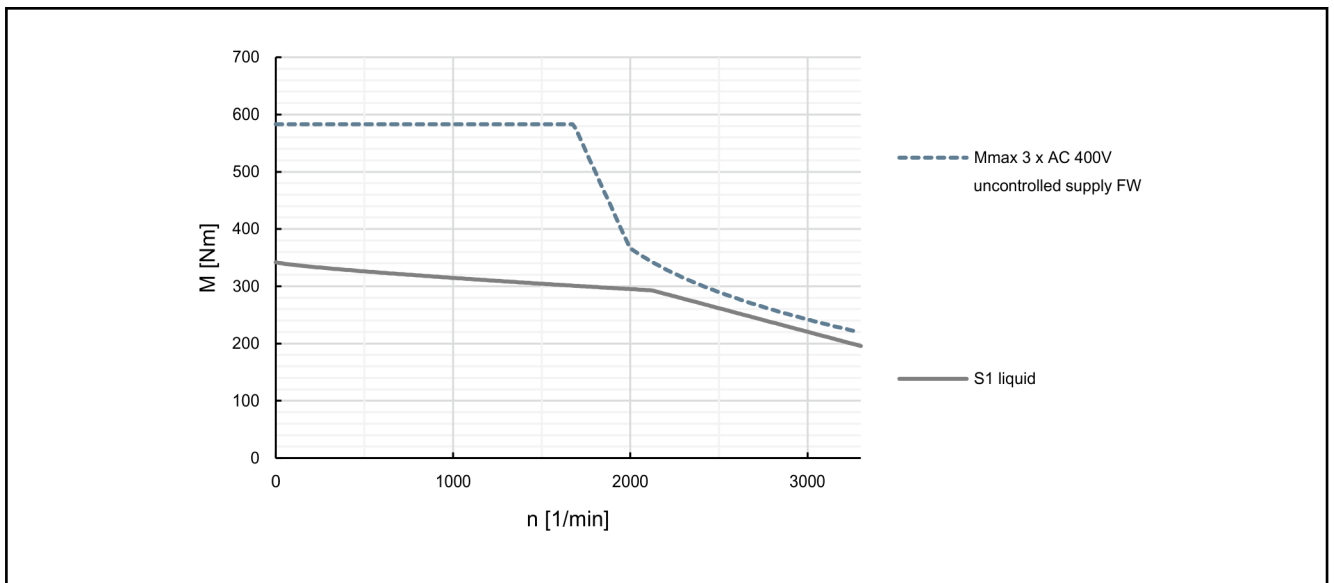

Fig. 4-96: Characteristic curves of motor MSK133E-0203-FN, uncontrolled supply 3 × AC 400 V (-5%) with reluctance characteristic curve and field weakening

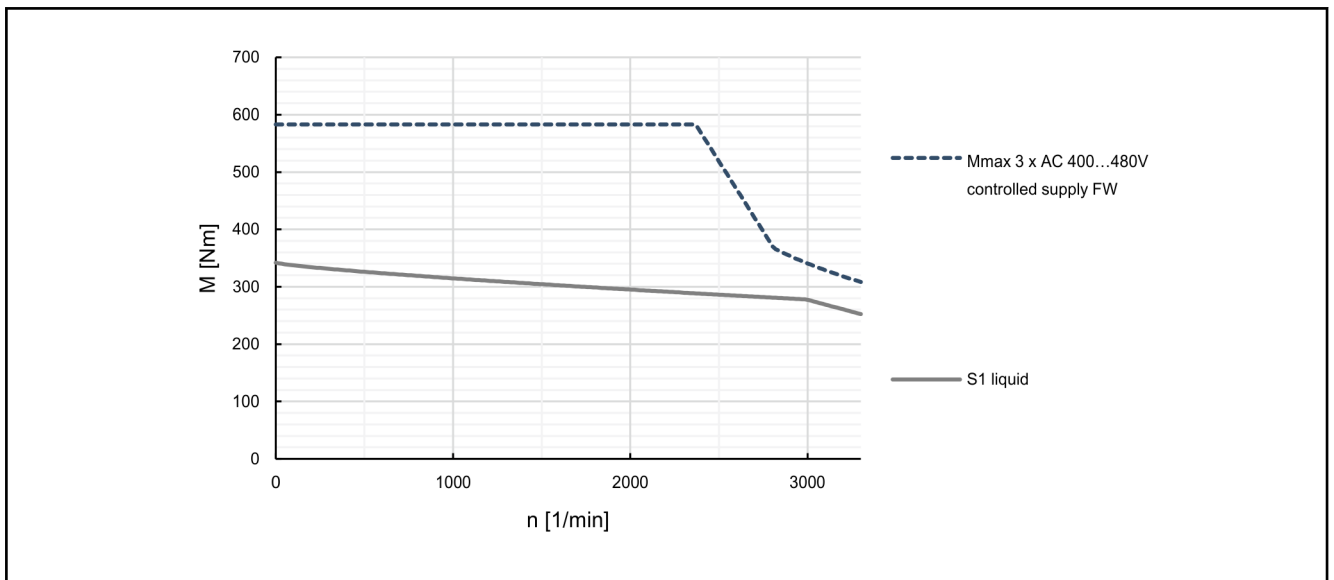

Fig. 4-97: Characteristic curves of motor MSK133E-0203-FN, controlled supply 3 × AC 400 V (-5%) with reluctance characteristic curve and field weakening

Technical data

4.42 MSK133 Technical data fan

Designation	Symbol	Unit	Value	
Nominal voltage	U_N	V	3× AC 400	3× AC 480
Air flow direction			B --> A	
Mean volume flow		m ³ /h	350	
Nominal frequency	f	Hz	50/60	
Fan current ¹⁾	I_N	A	0,19 / 0,28	0,18 / 0,26
Blocking current	I_{Block}	A	0,55 / 0,47	0,62 / 0,55
Power consumption	S_N	VA	132 / 197	151 / 217
Degree of protection			IP65	

1) Fan current monitoring from $1.2 \times I_N$

Tab. 4-41: MSK133 fan - technical data

The connection of the fan unit is done via RLS0782 connector.

5 Specifications

5.1 Technical design

Motor Design	Motor frame size B5 acc. to EN60034-7 (for additional information see chapter 9.3 "Design and installation positions" on page 208)
Housing varnish	Black (RAL9005)
Vibration severity grade (quality of vibration)	Level A, acc. to EN 60034-14:2004
Concentricity, run-out and alignment	according to DIN 42955, Edition 12.81 (IEC 60072-1)

Encoder	Concentricity tolerance		Concentricity and alignment tolerance	
S1, S3, M1, M3	N	---	N	---
S2, M2	---	R	---	R

Tab. 5-1: Tolerance for concentricity, run-out and alignment depend from the encoder option

Flange	according to DIN 42948, ed. 11.65.
Output shaft, shaft end and centering hole	All motors with keyway are balanced with complete key. The machine element to be driven must be balanced without a key. Shaft end cylindrical according to DIN 748, Part 3, ed. 07.75. IEC 60072 (-1). Centering hole, according to DIN 332 Part 2, Edition 05.83

Motor	Key DIN 6885-A ¹⁾	Centering hole DIN 332 Part 2
MSK030	3×3×16	DS M3
MSK040	5×5 ×20	DS M5
MSK043	5×5 ×20	DS M5
MSK050	6×6×32	DS M6
MSK060	8×7×40	DS M8
MSK061	6×6×32	DS M6
MSK070	10×8×45	DS M10
MSK071	10×8×45	DS M10
MSK075	10×8×45	DS M10
MSK076	8×7×40	DS M8
MSK100	10×8×45	DS M10
MSK101	10×8×70	DS M12
MSK103	-	DS M12
MSK131	14×10×80	DS M16
MSK133	-	DS M16

1) not in the scope of delivery

Tab. 5-2: Key and centering hole

Specifications

5.2 MSK030 Specifications

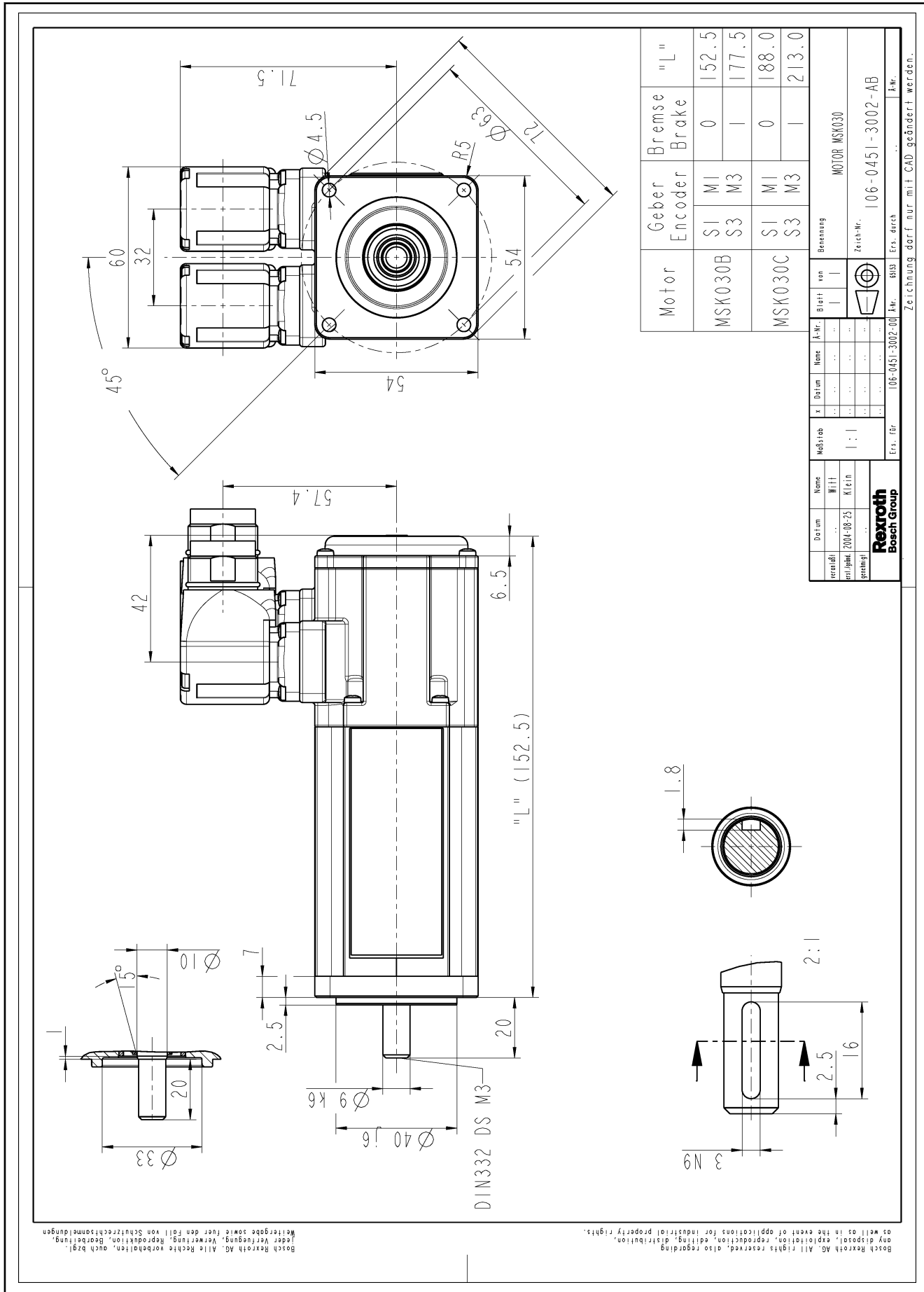

Fig. 5-1: MSK030 specification

5.3 MSK040 Specifications

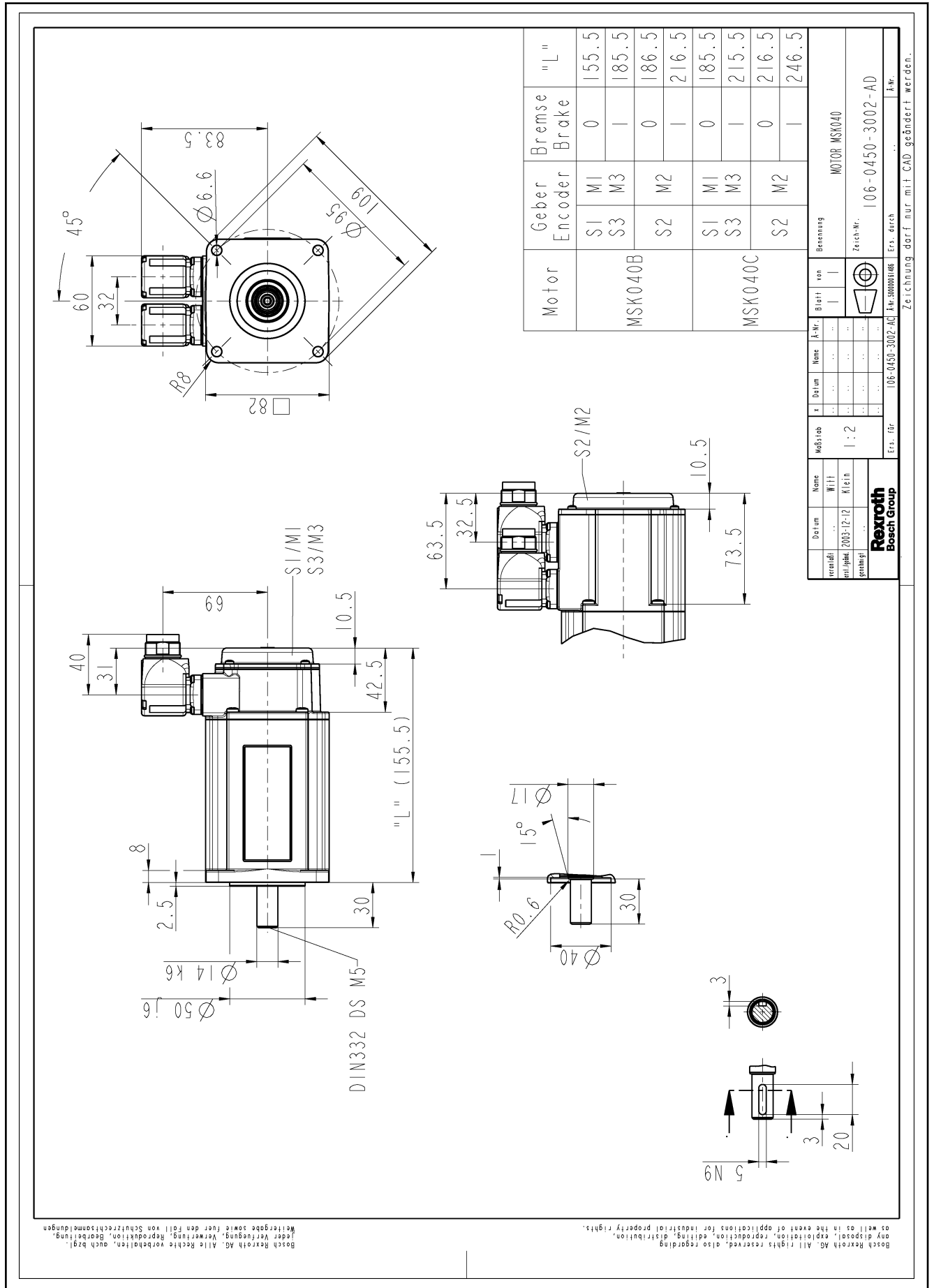

Fig. 5-2: MSK040 specification

Specifications

5.4 MSK043 Specifications

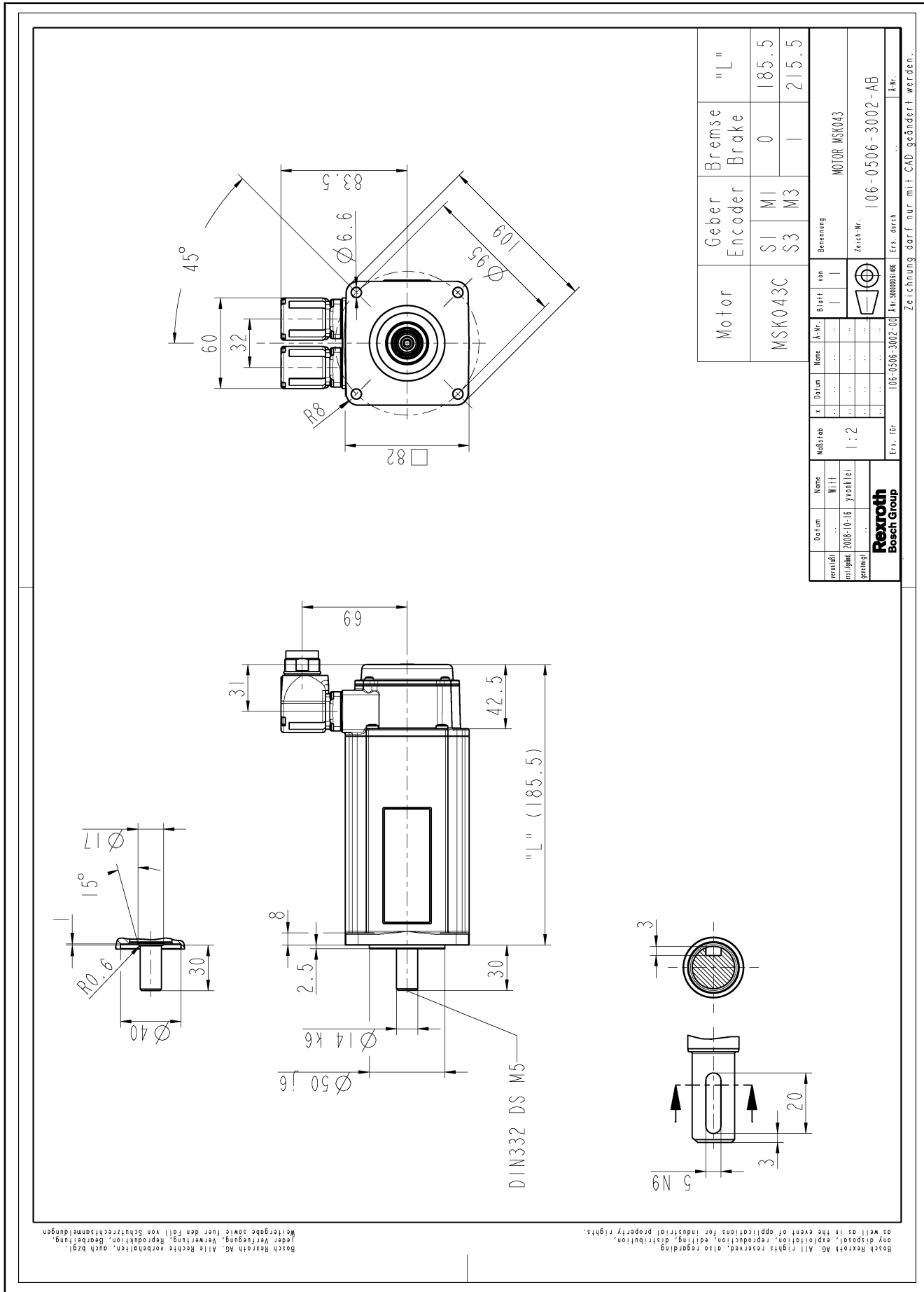

Fig. 5-3: MSK043 Specifications

5.5 MSK050 Specifications

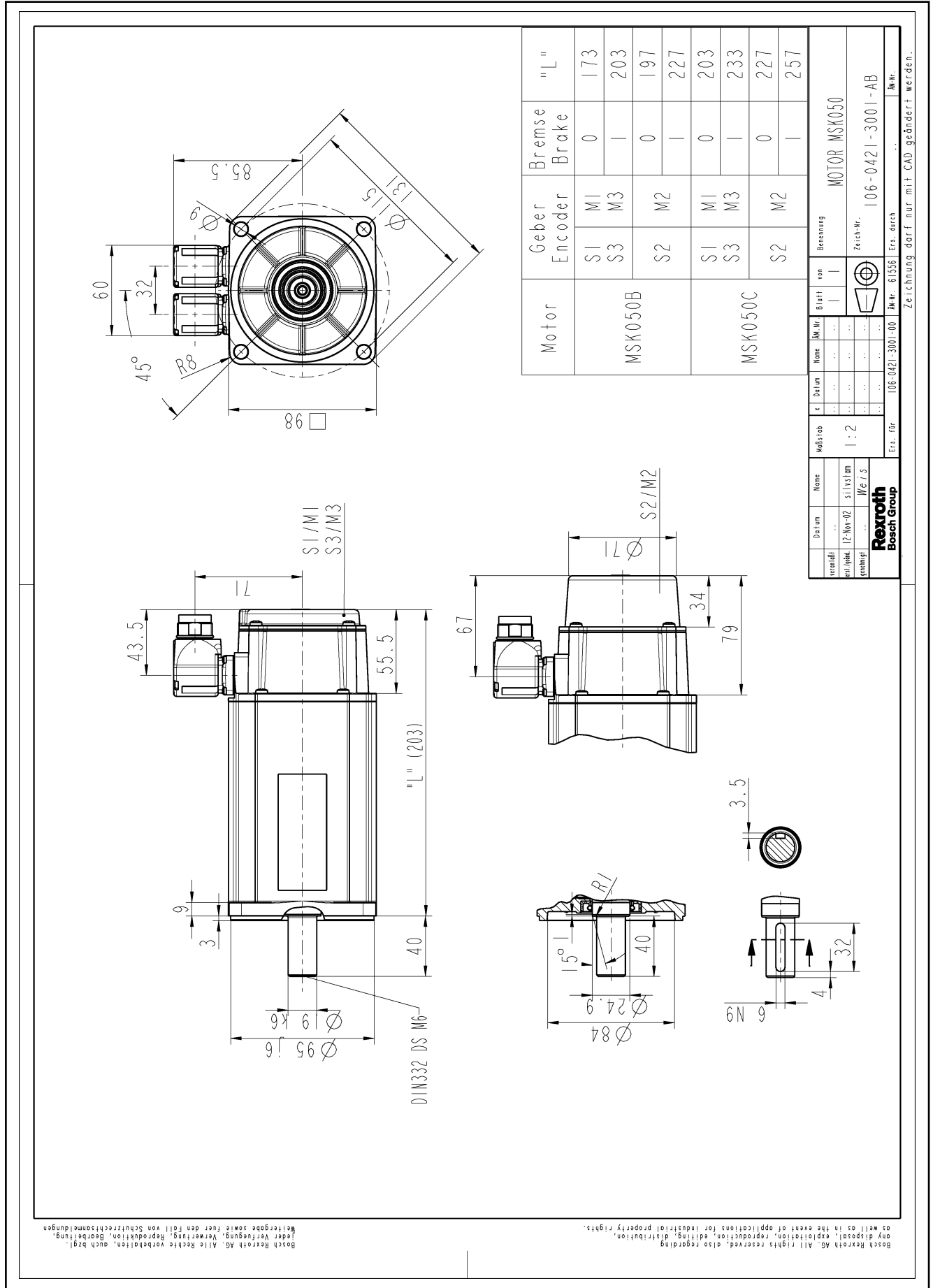

Fig. 5-4: MSK050 specification

Specifications

5.6 MSK060 Specifications

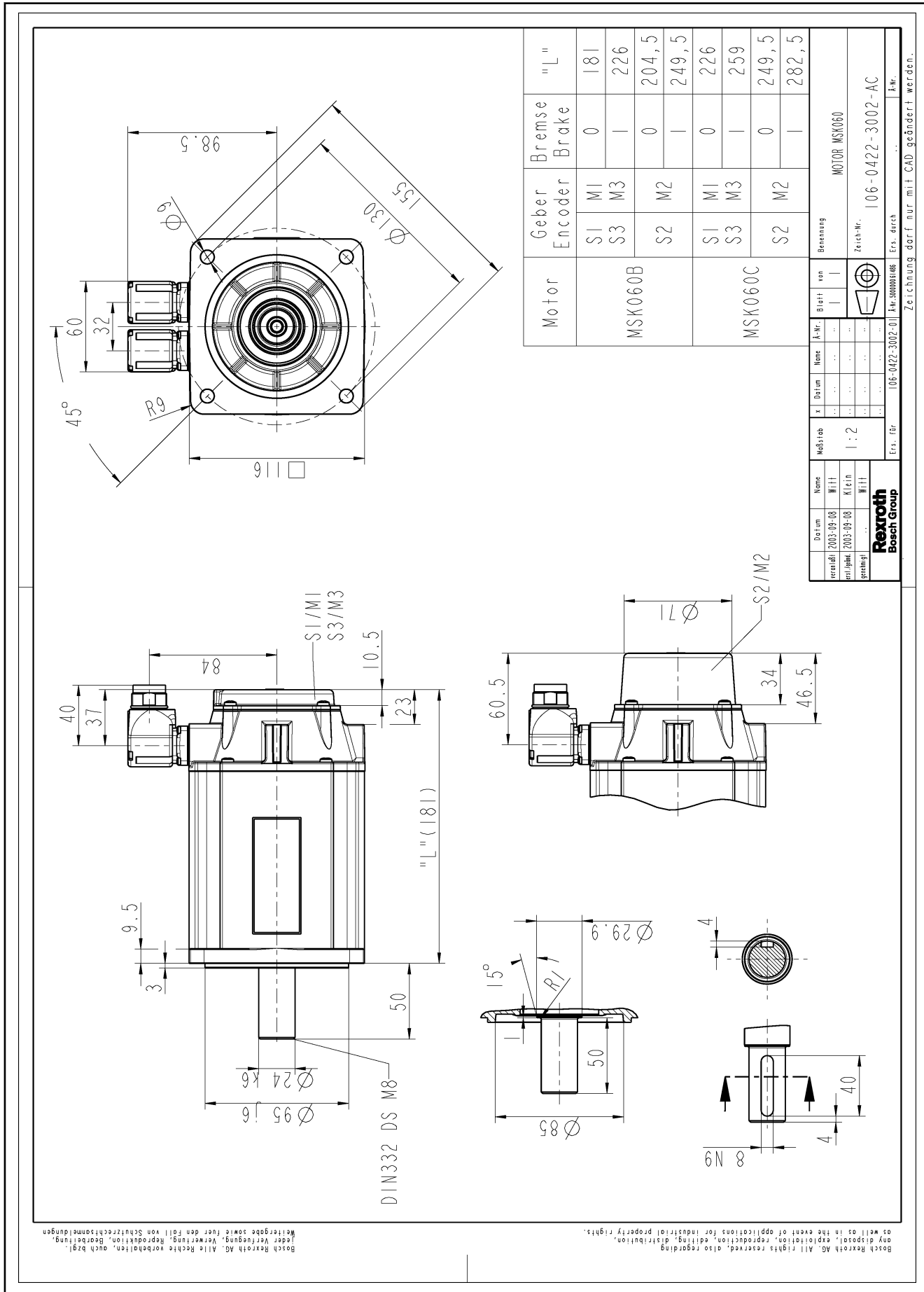

Fig. 5-5: MSK060 specification

5.7 MSK060 Specifications fan unit axial

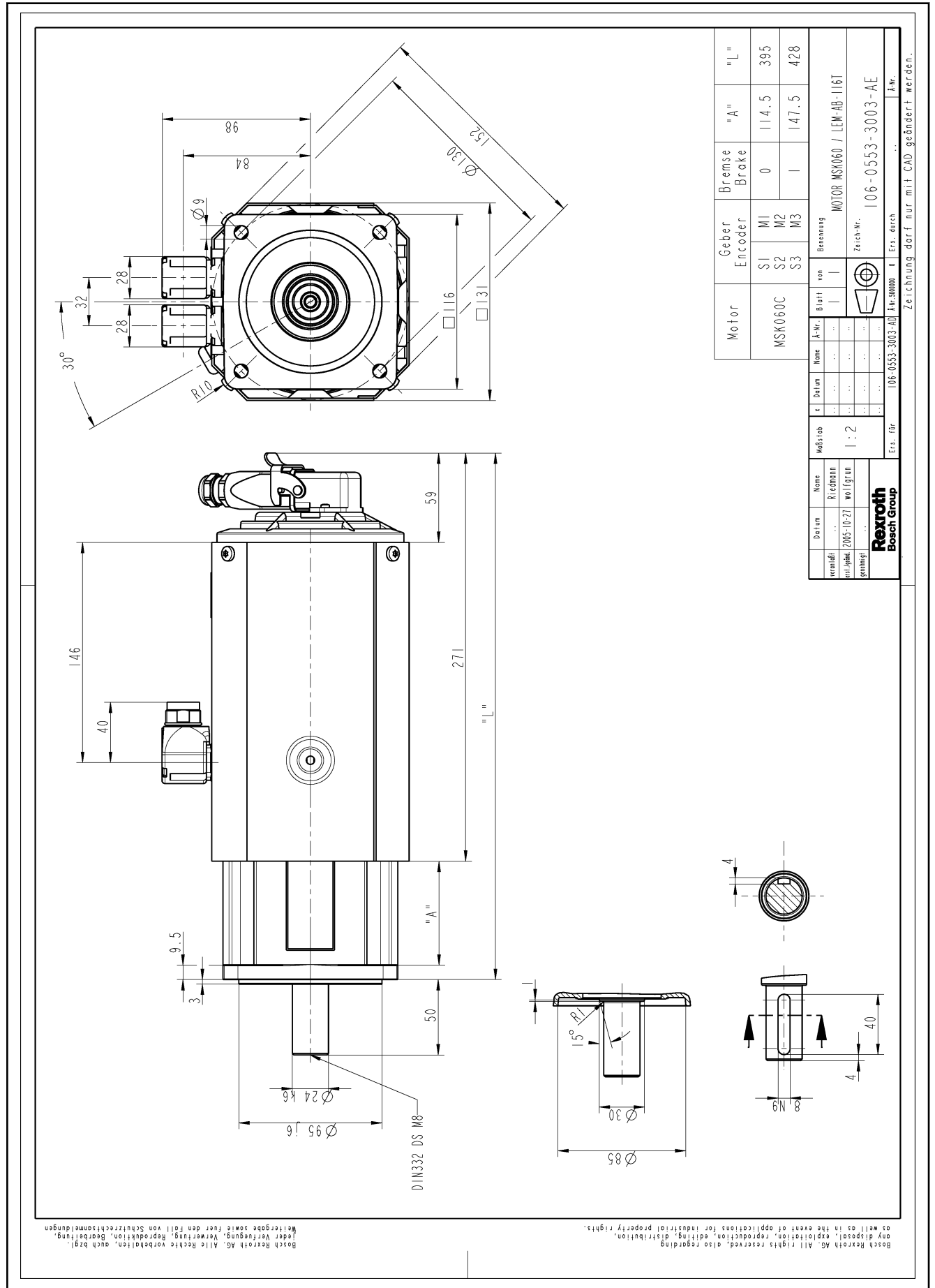

Fig. 5-6: Dimension sheet MSK060 with axial fan unit

Specifications

5.8 MSK060 Specifications fan unit radial

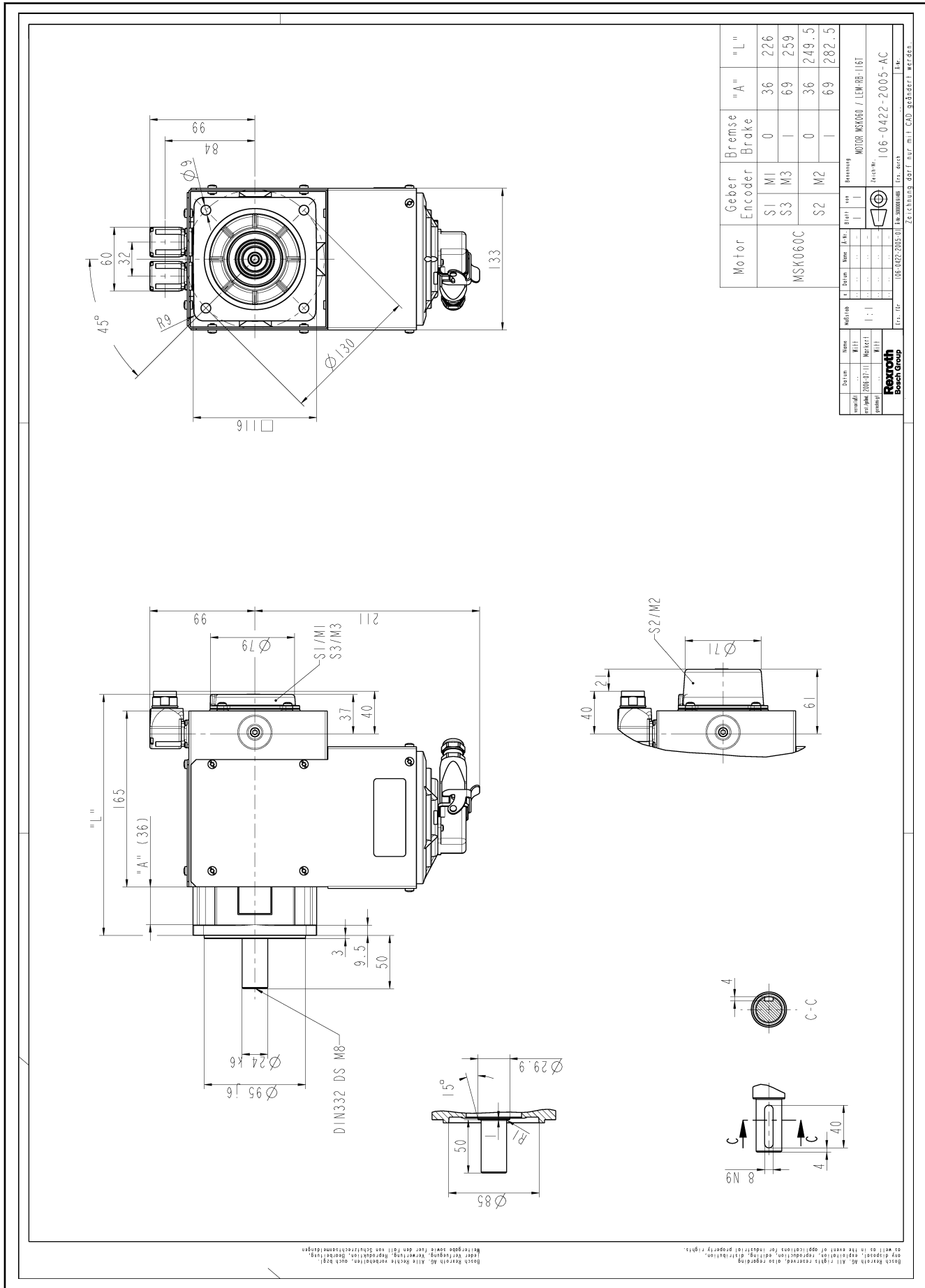
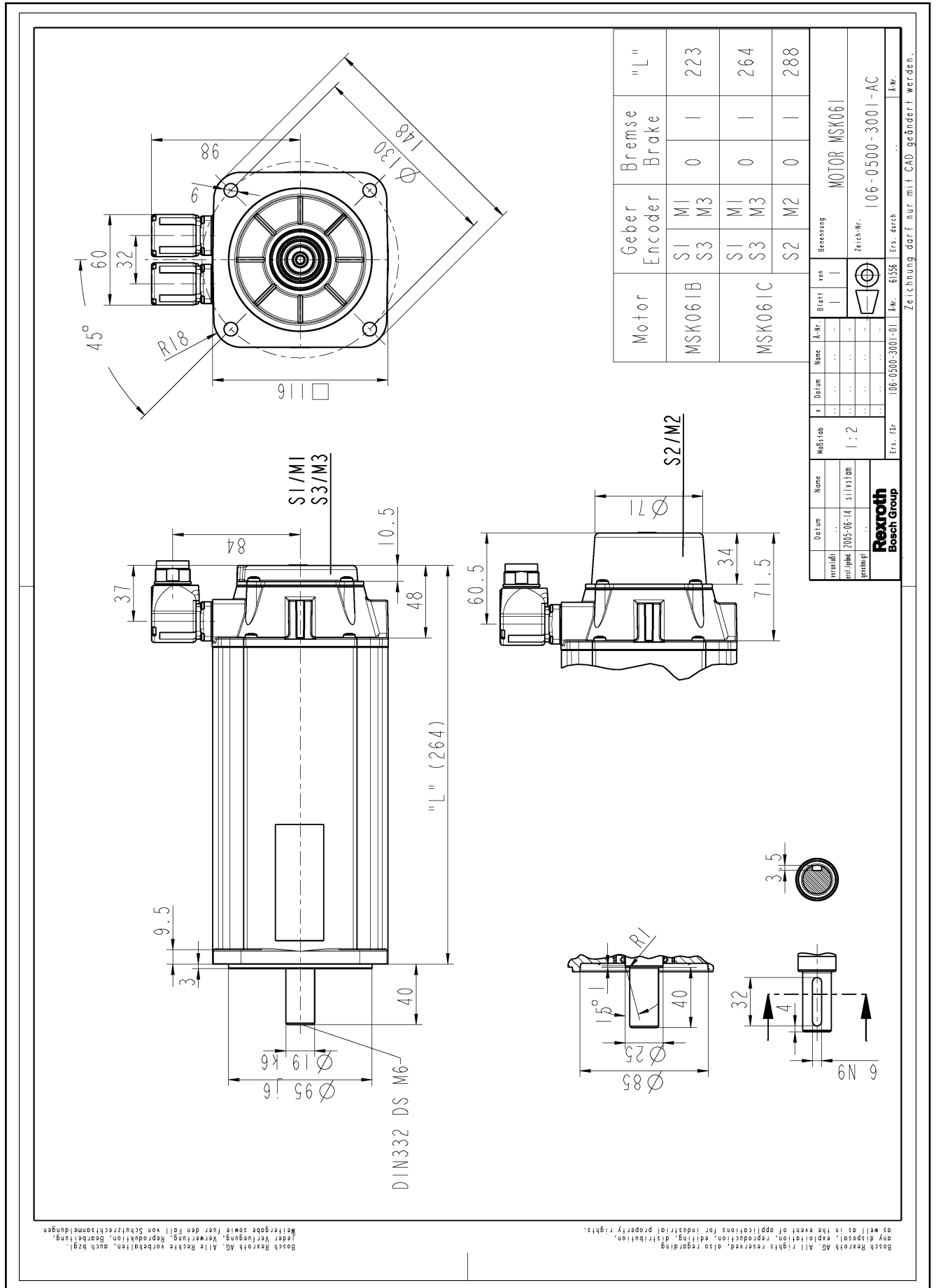

Fig. 5-7: Dimension sheet MSK060 with radial fan unit

5.9 MSK061 Specifications



Specifications

5.10 MSK061 Specifications fan unit axial

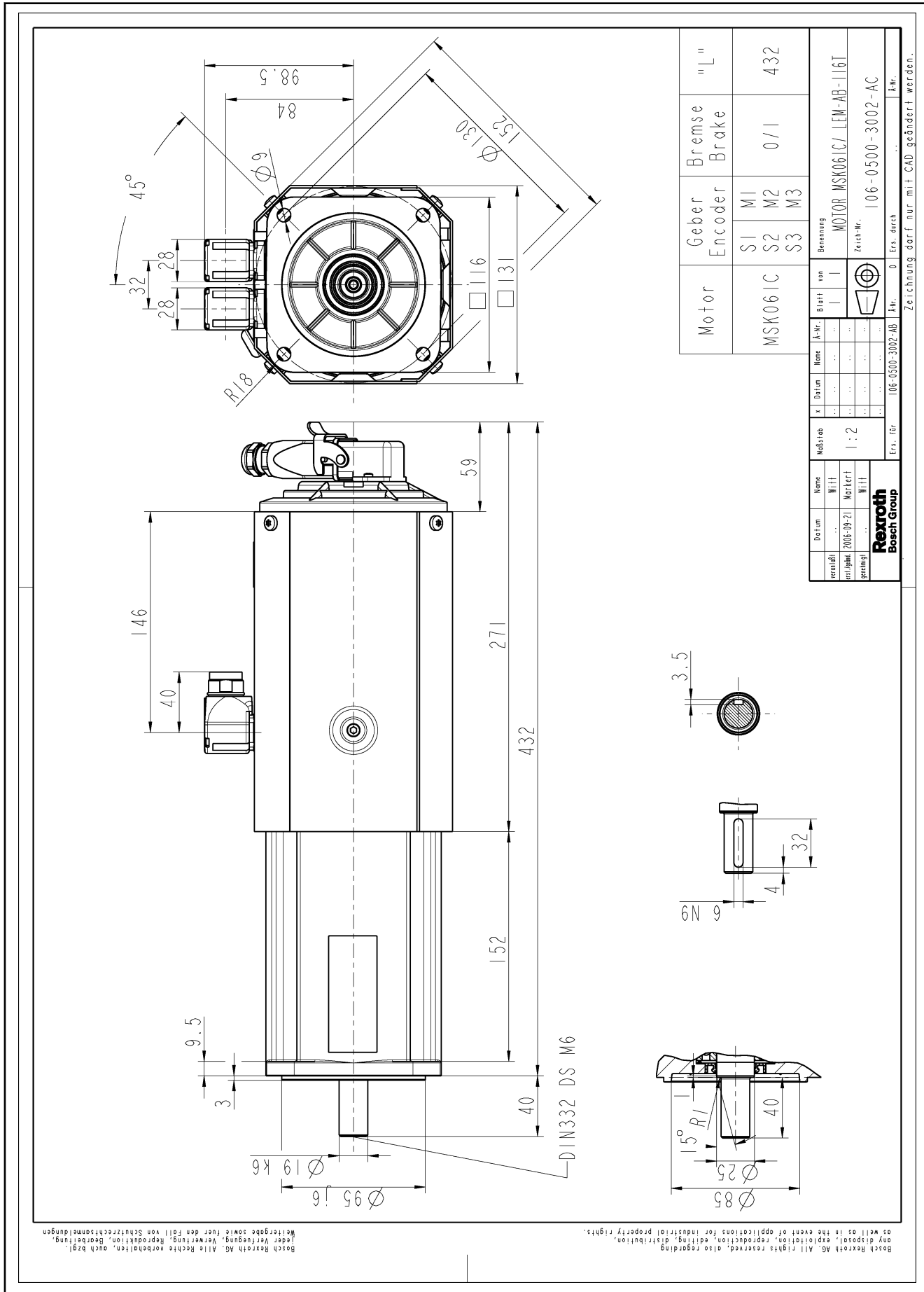

Fig. 5-9: Dimension sheet MSK061 with axial fan unit

5.11 MSK061 Specifications fan unit radial

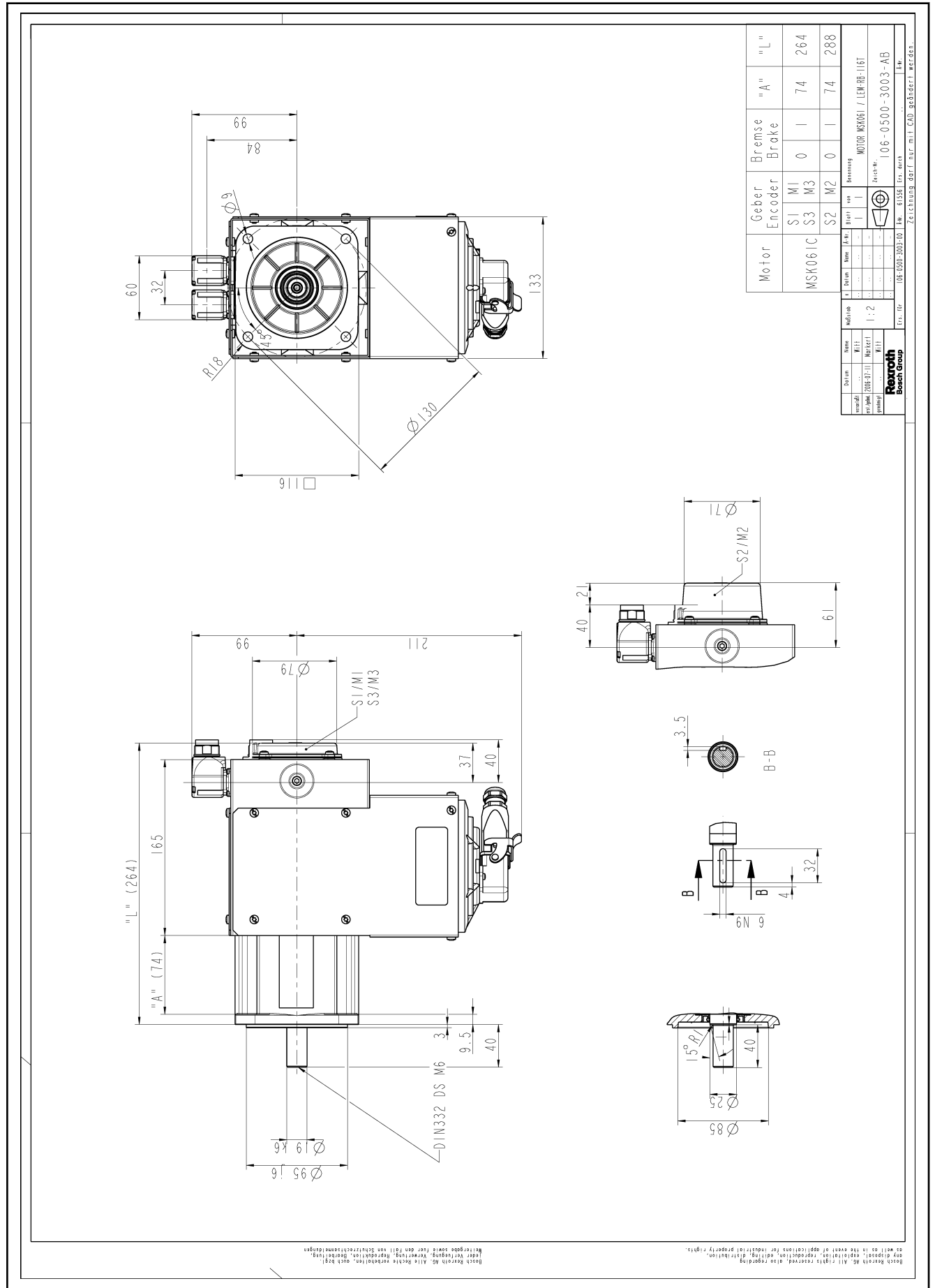

Fig. 5-10: Dimension sheet MSK061 with radial fan unit

Specifications

5.12 MSK070 Specifications

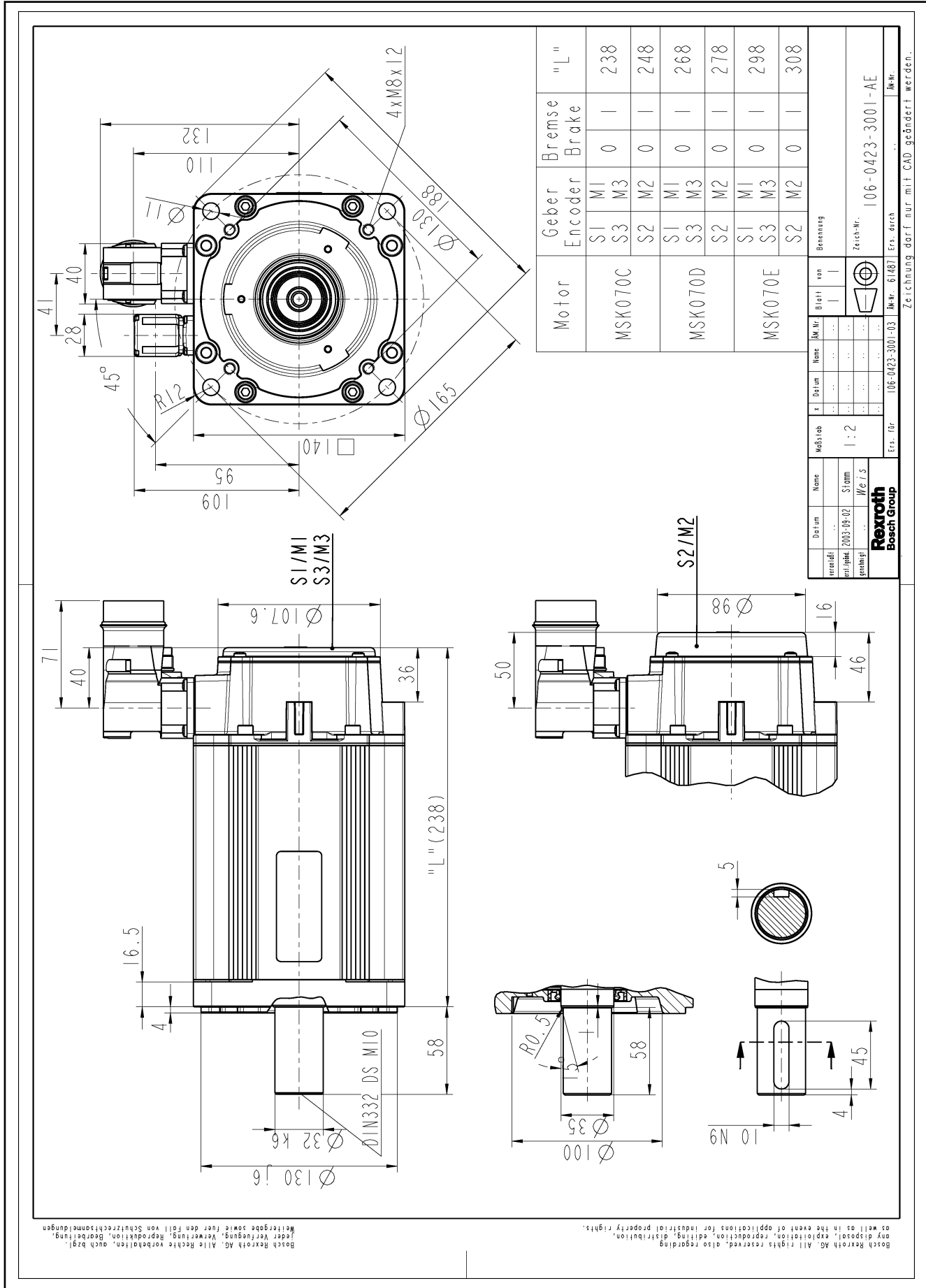

Fig. 5-11: MSK070 specification

5.13 MSK070 Specifications fan unit axial

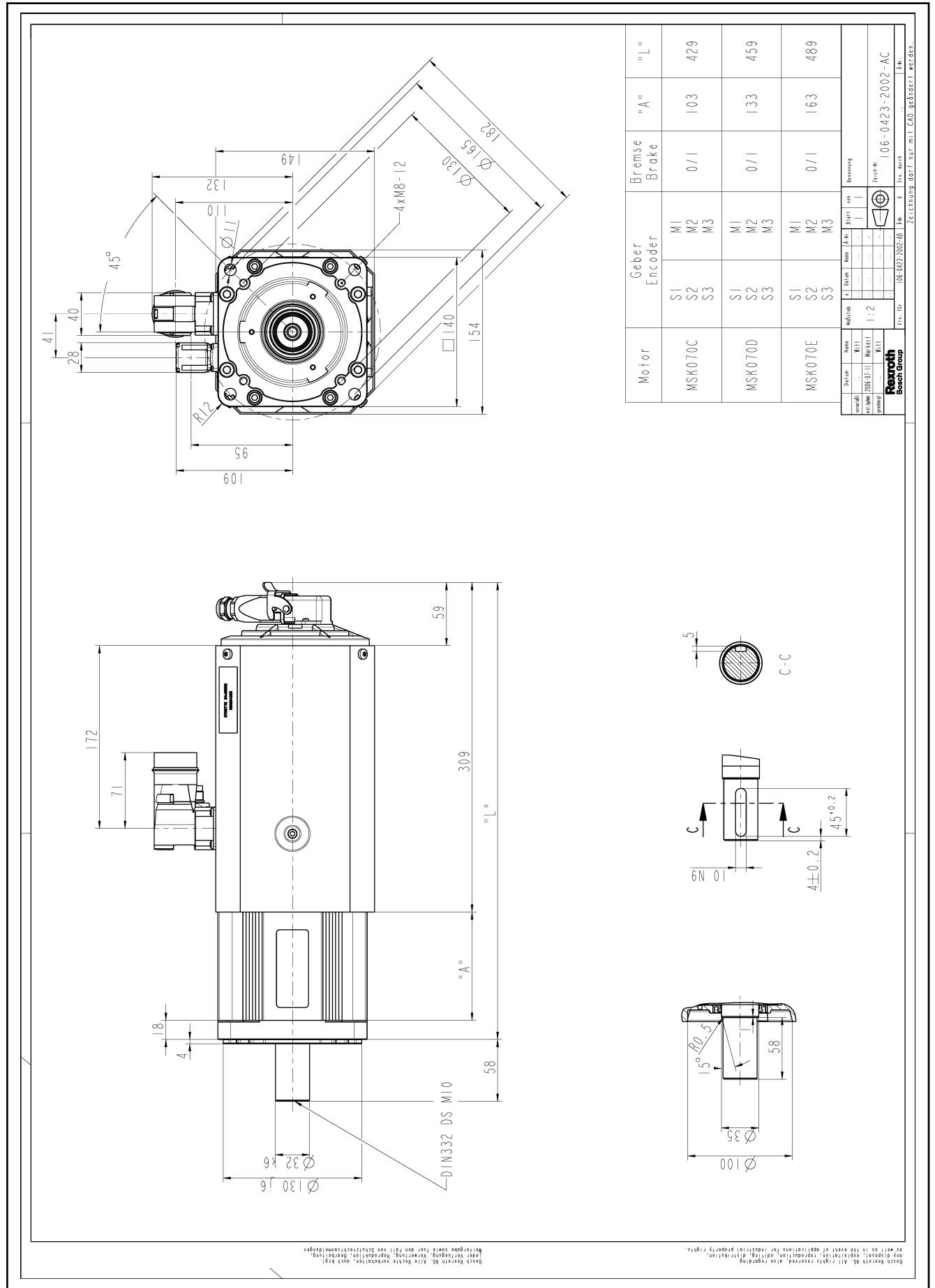

Fig. 5-12: Dimension sheet MSK070 with axial fan unit

Specifications

5.14 MSK070 Specifications fan unit radial

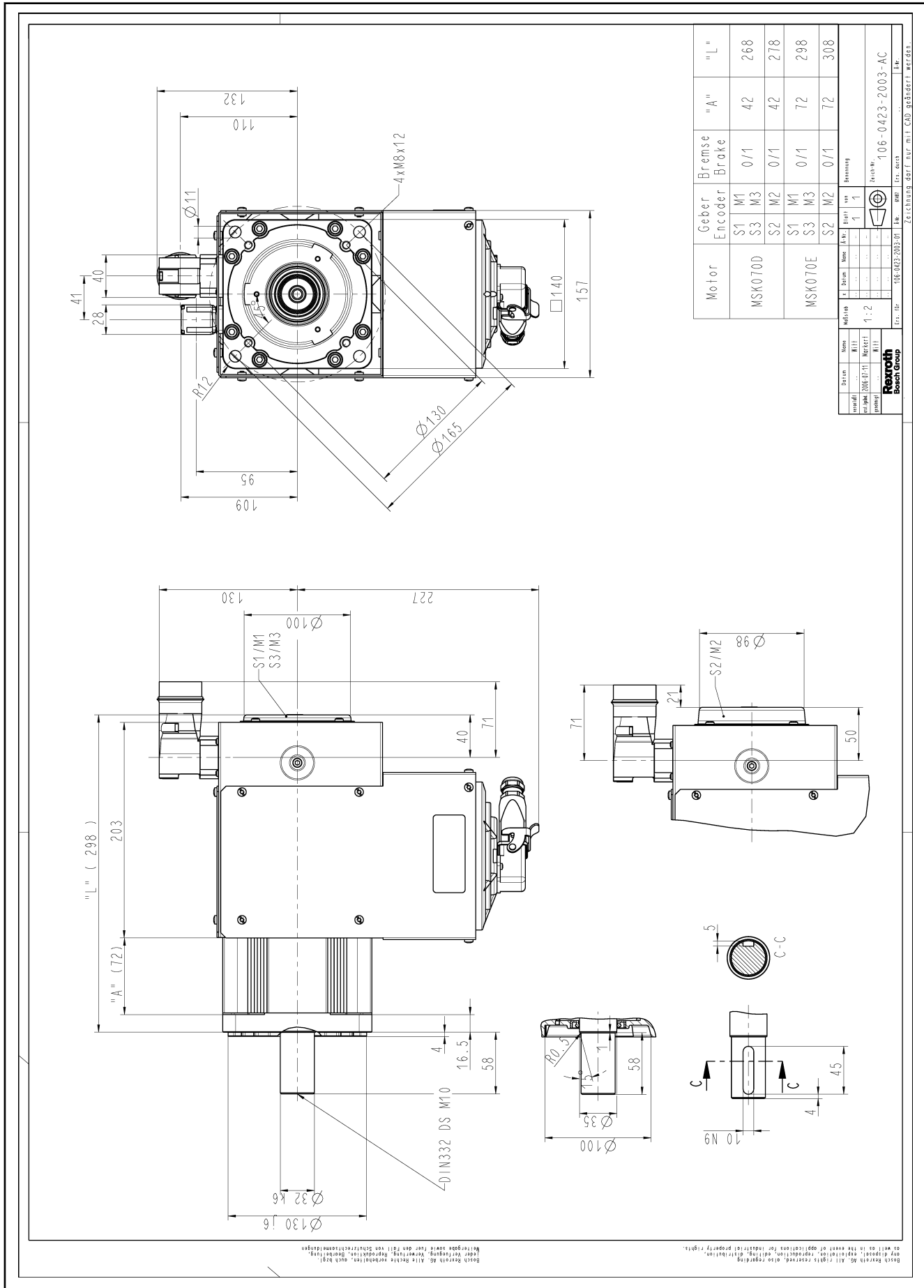

Fig. 5-13: Dimension sheet MSK070 with radial fan unit

5.15 MSK071 Specifications

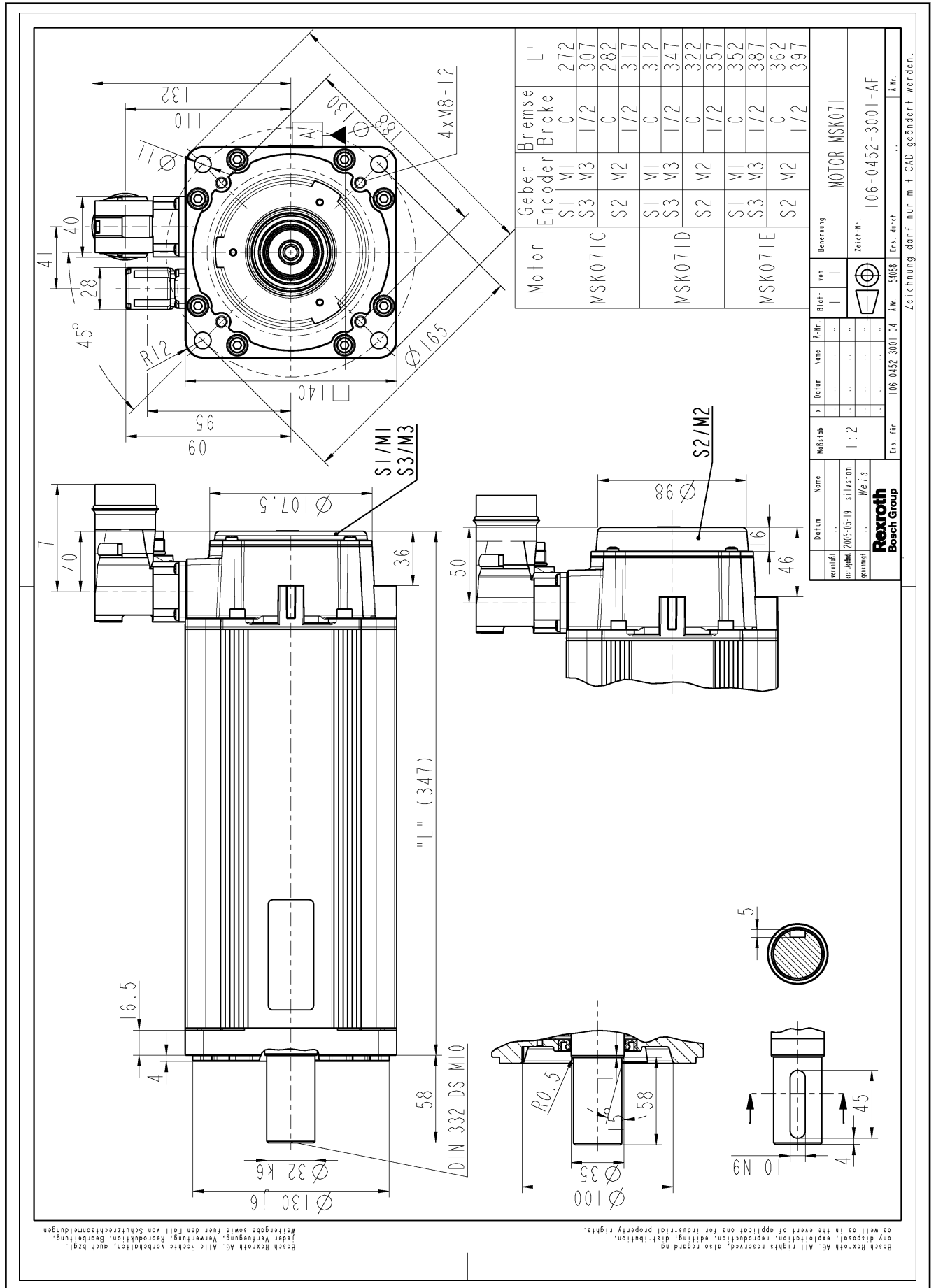

Fig. 5-14: MSK071...NN specification

5.17 MSK071 Specifications fan unit axial

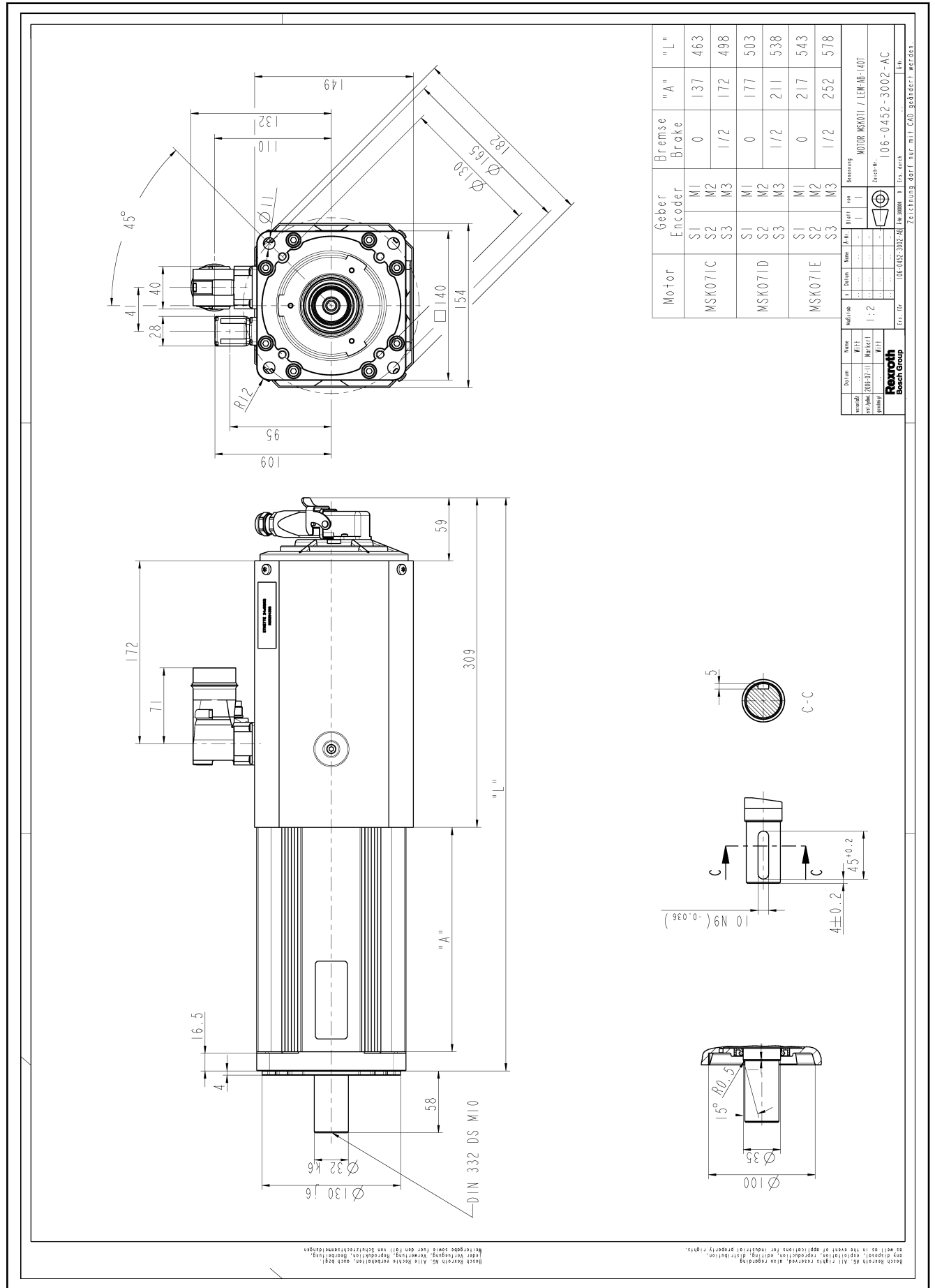

Fig. 5-16: Dimension sheet MSK071 with axial fan unit

Specifications

5.18 MSK071 Specifications fan unit radial

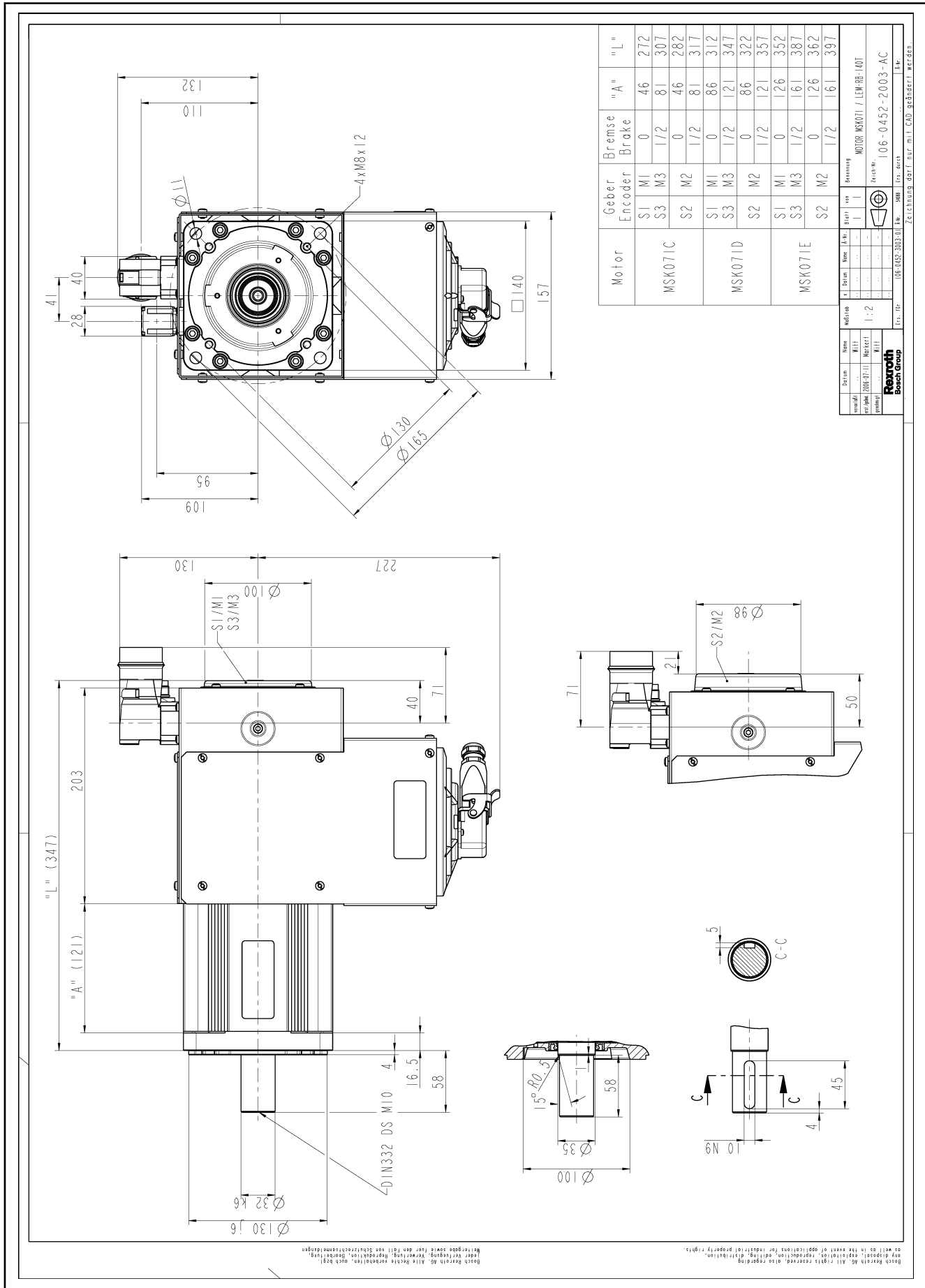

Fig. 5-17: Dimension sheet MSK071 with radial fan unit

5.19 MSK075 Specifications

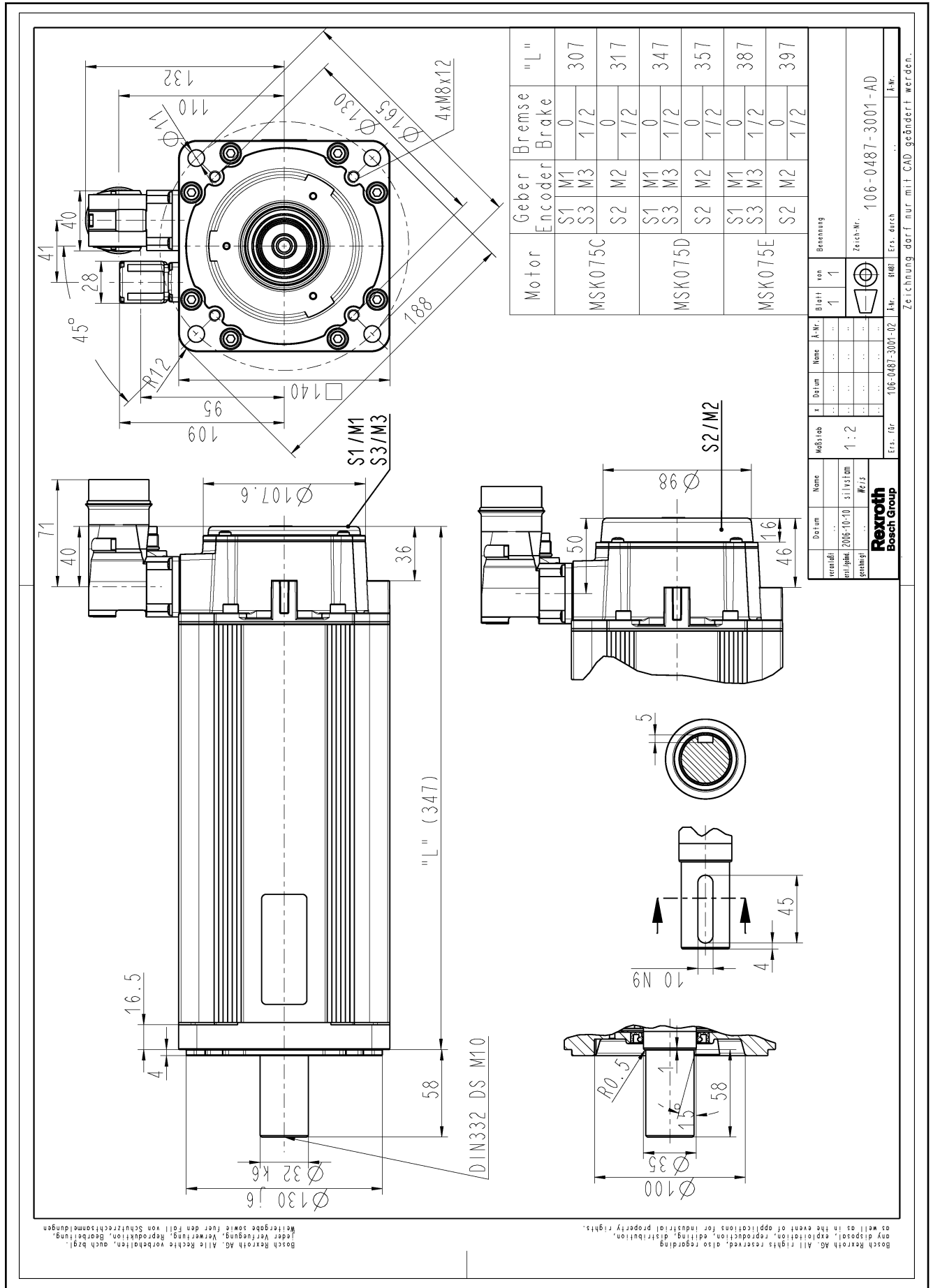

Fig. 5-18: MSK075...NN specification

5.21 MSK075 Specifications axial fan unit

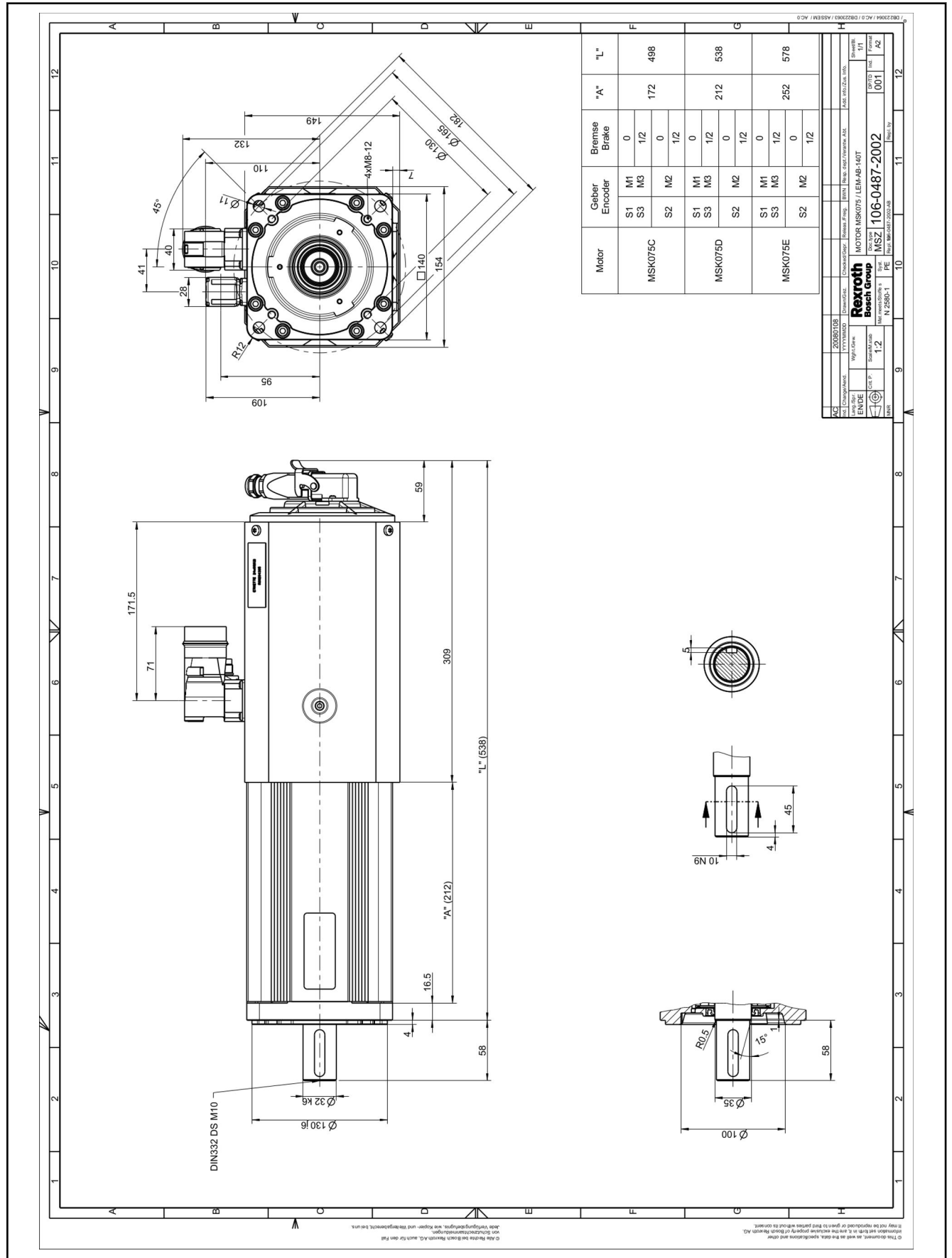

Fig. 5-20: Dimension drawing MSK075 with axial fan unit

Specifications

5.22 MSK075 Specifications fan unit radial

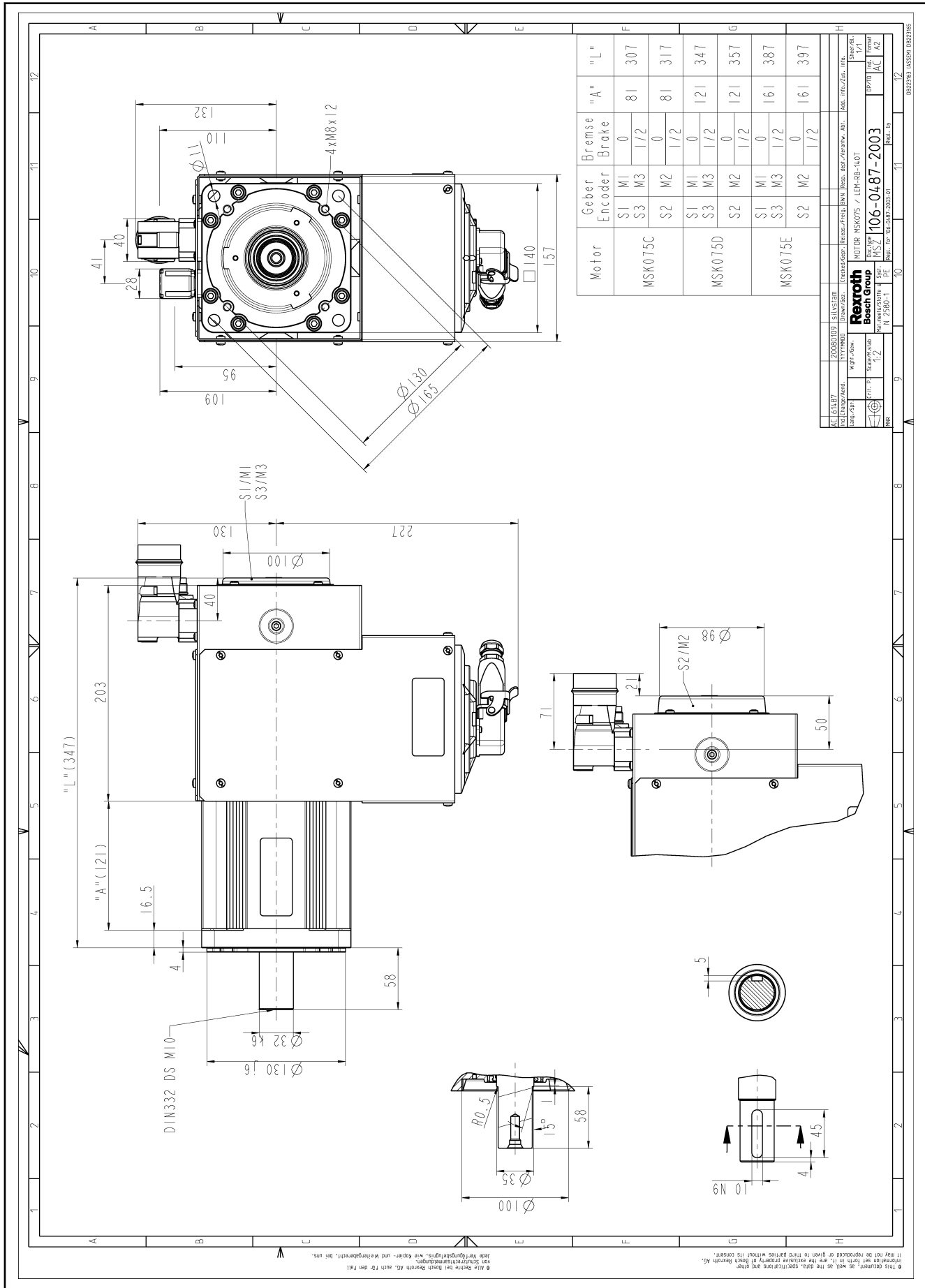

Fig. 5-21: Dimension sheet MSK075 with radial fan unit

5.23 MSK076 Specifications

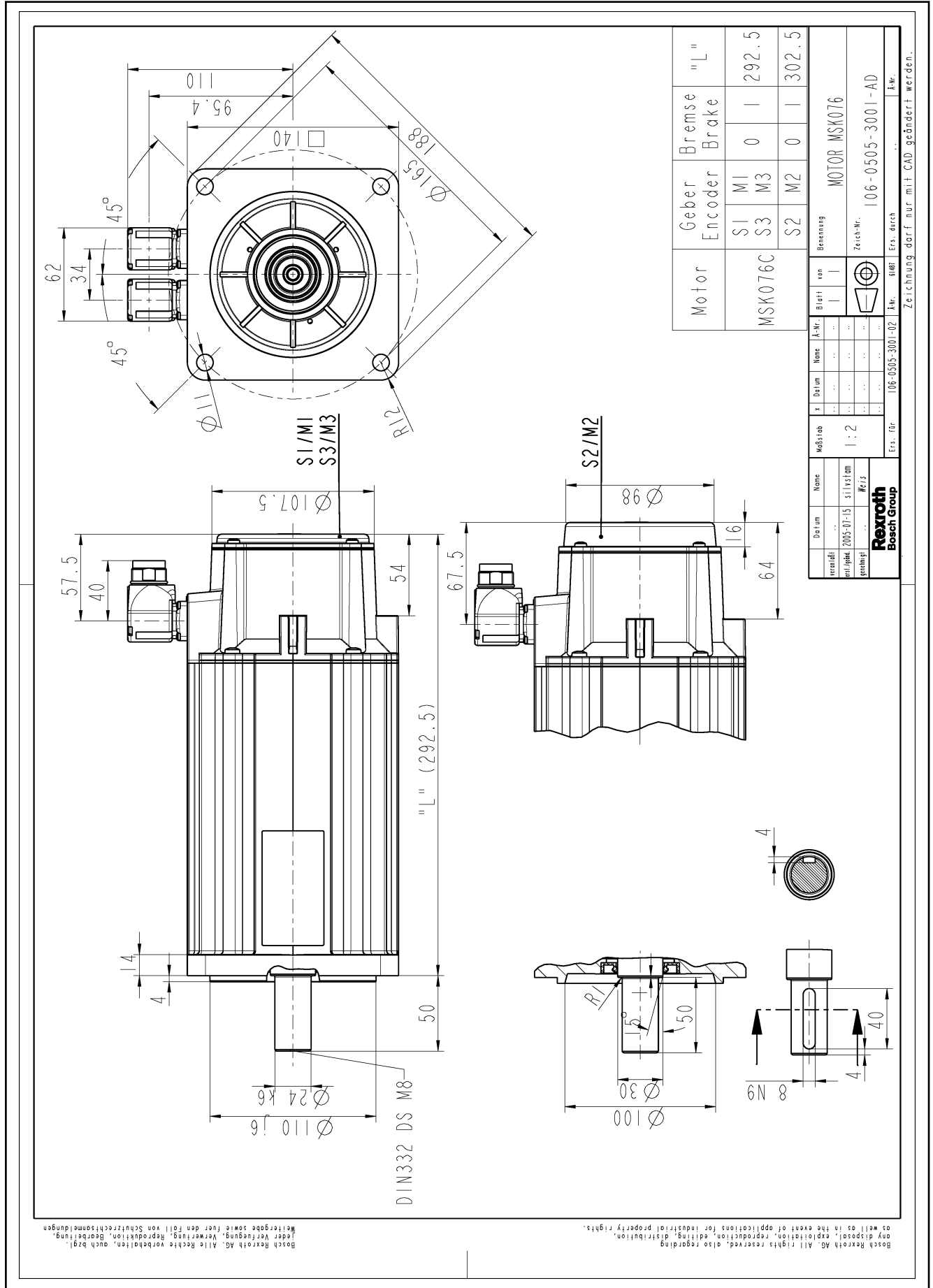

Fig. 5-22: MSK076 specification

Specifications

5.24 MSK076 Specifications fan unit axial

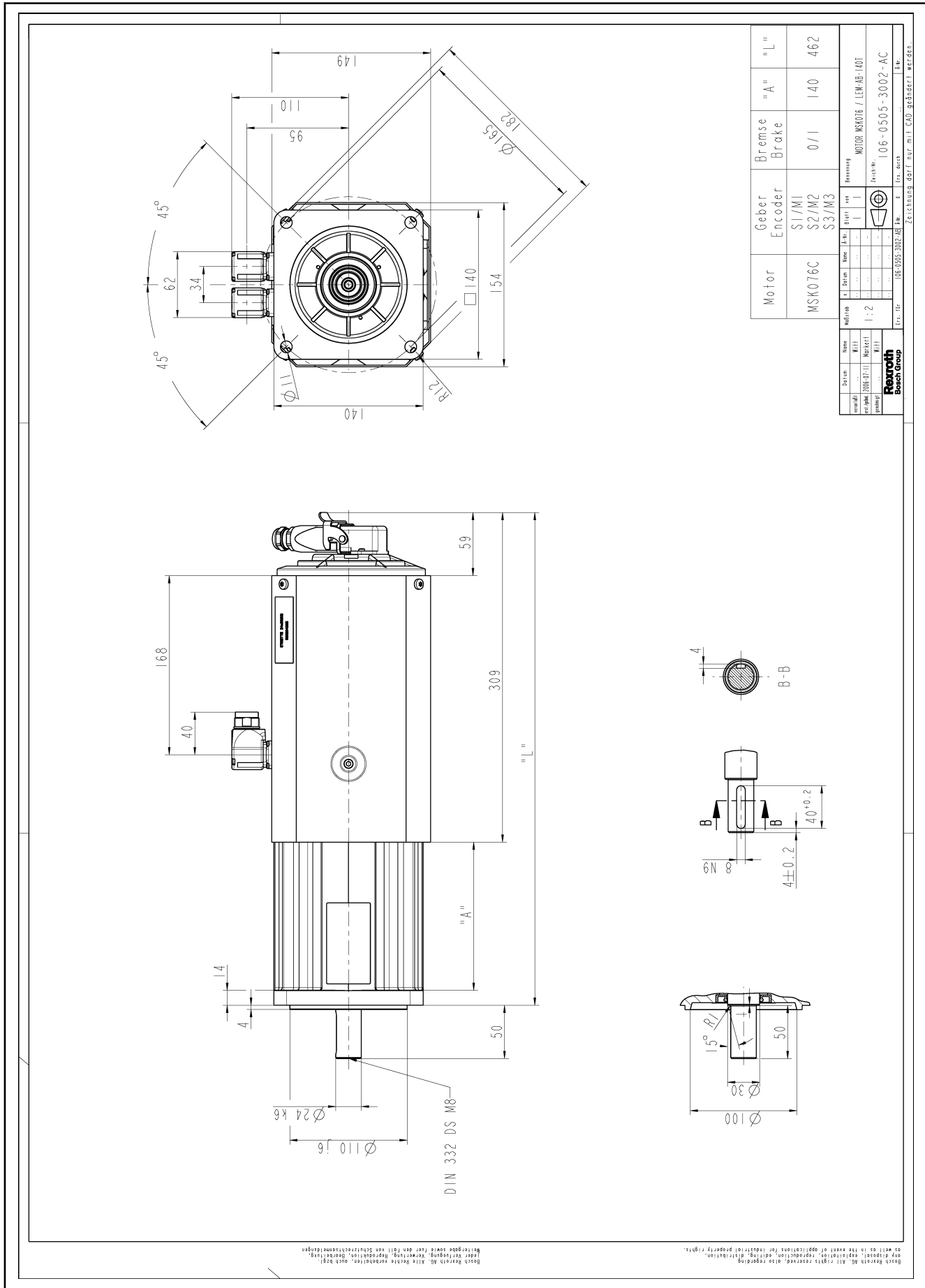

Fig. 5-23: Dimension sheet MSK076 with axial fan unit

5.25 MSK076 Specifications fan unit radial

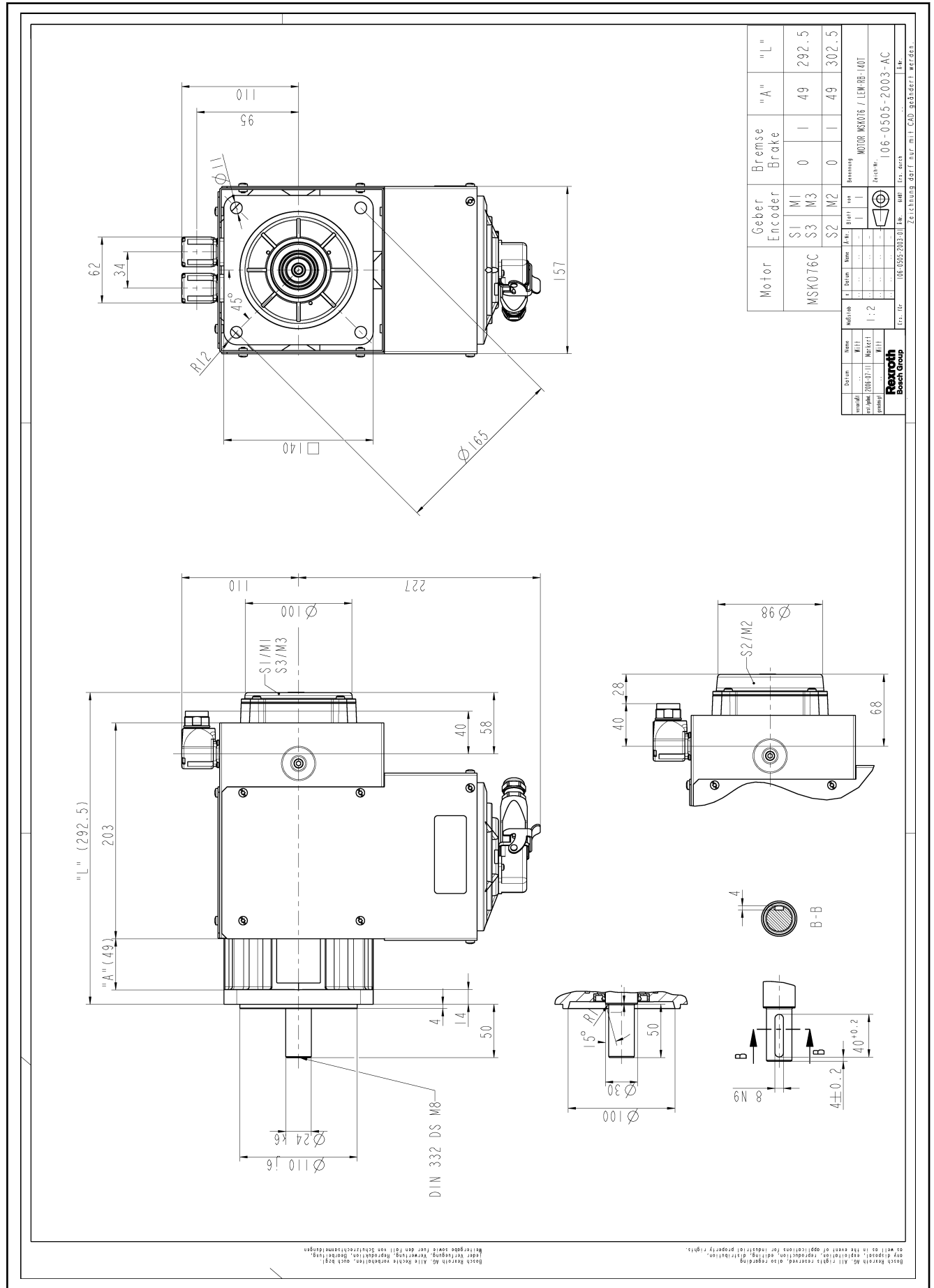

Fig. 5-24: Dimension sheet MSK076 with radial fan unit

Specifications

5.26 MSK100 Specifications

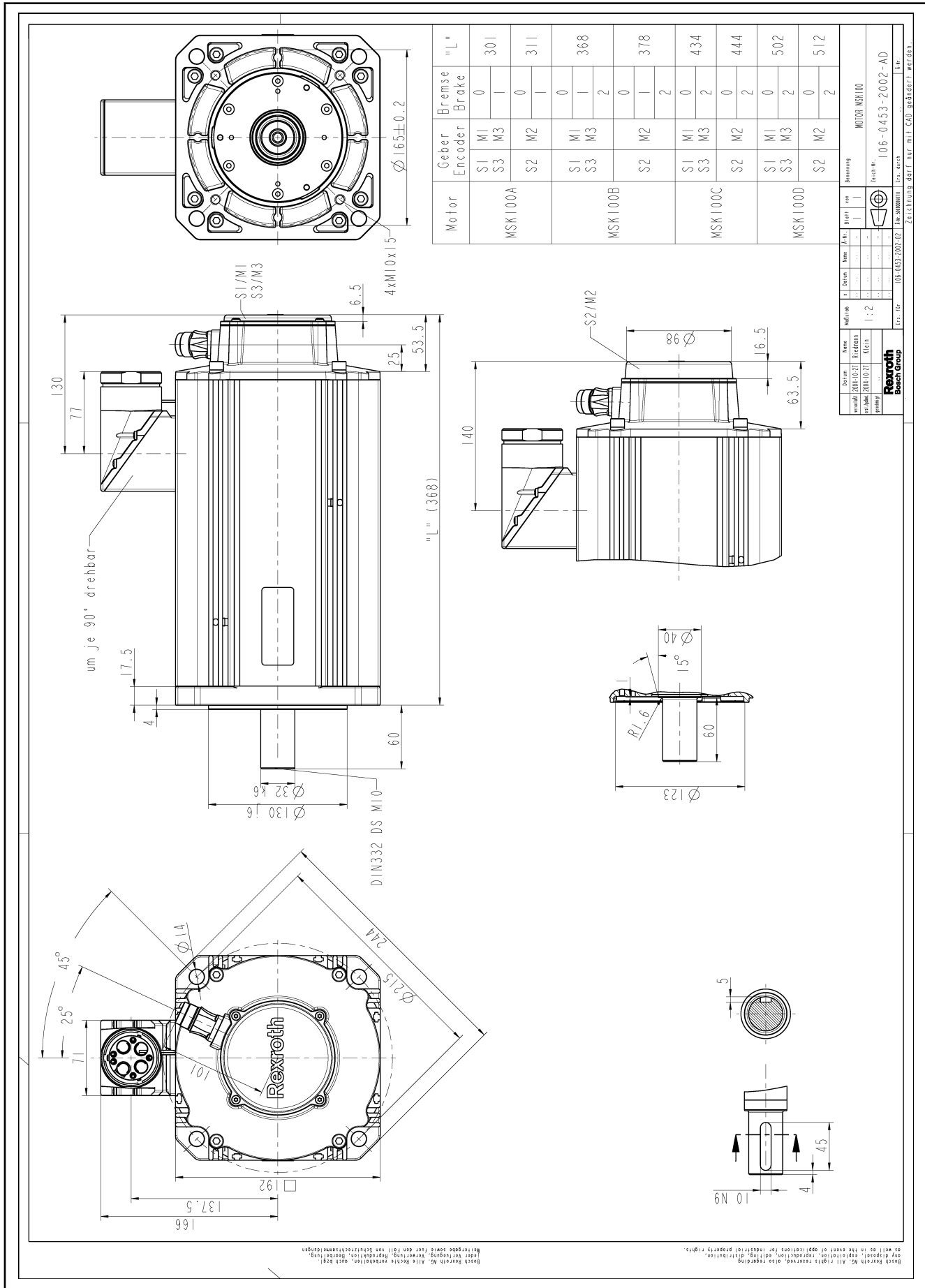

Fig. 5-25: MSK100 specification

5.27 MSK100 Specifications fan unit axial

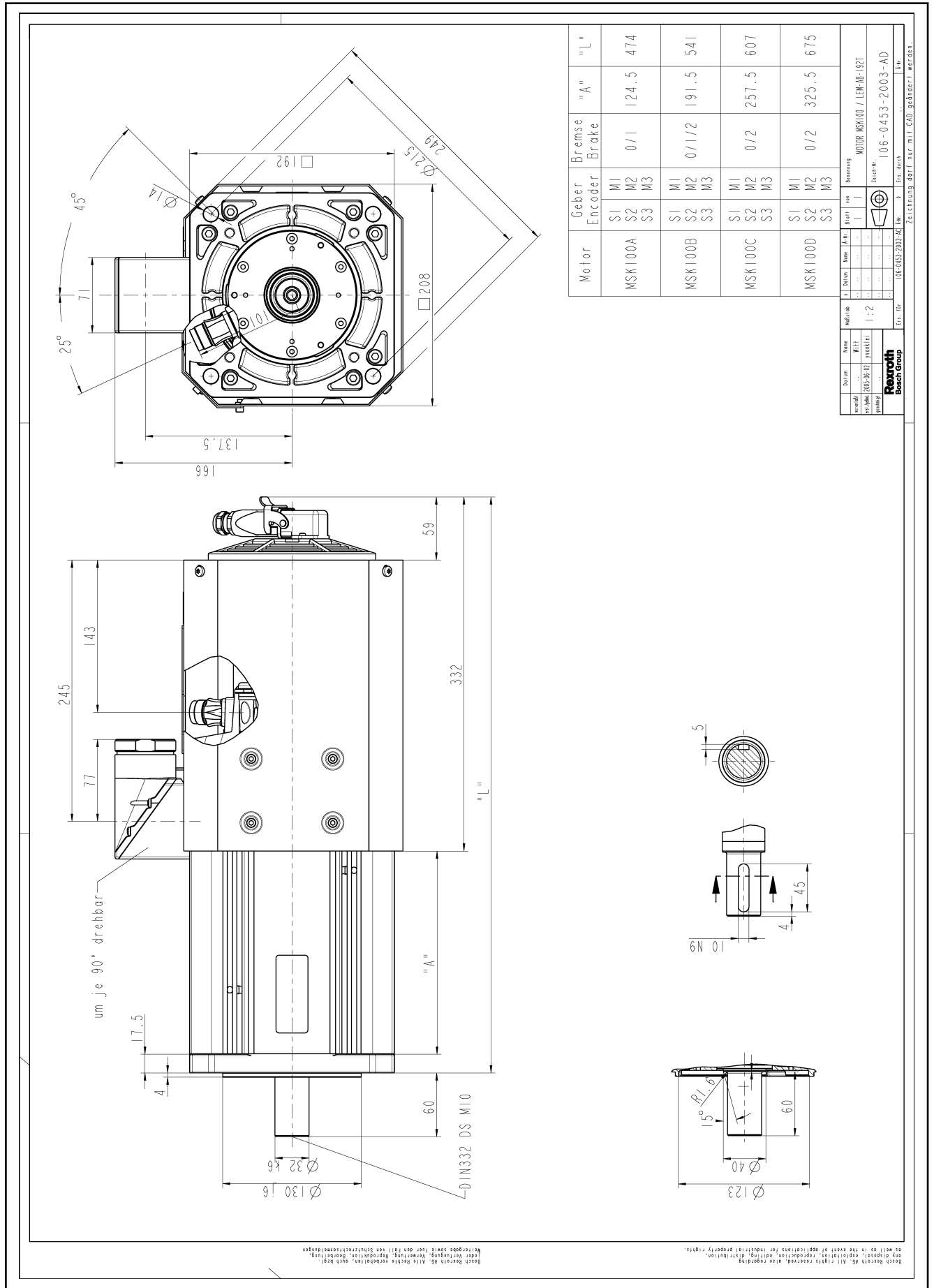

Fig. 5-26: Dimension sheet MSK060 with axial fan unit

Specifications

5.28 MSK100 Specifications radial fan unit

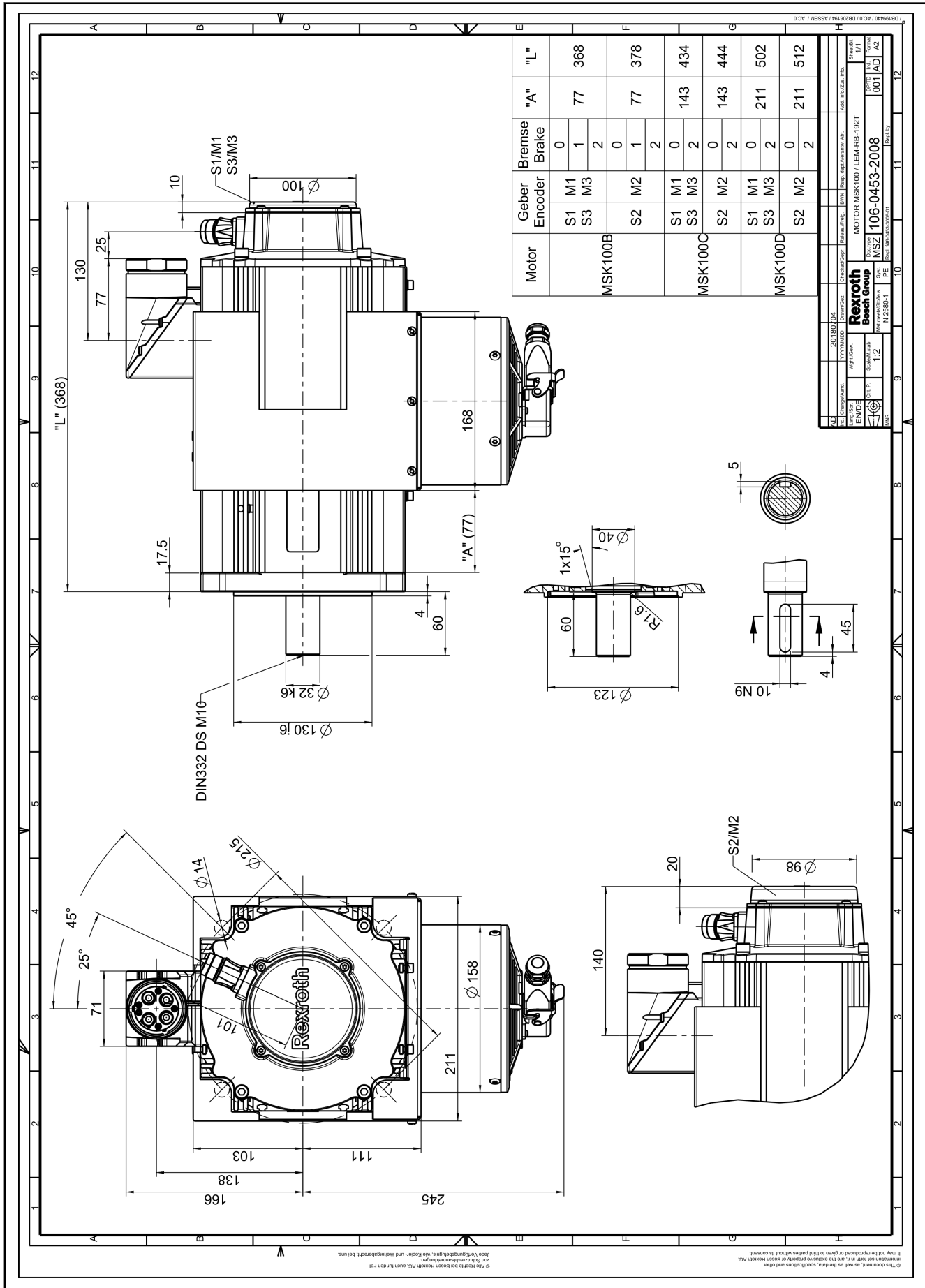

Fig. 5-27: Dimension drawing MSK100 with radial fan unit

Specifications

5.30 MSK101 Specifications liquid cooling

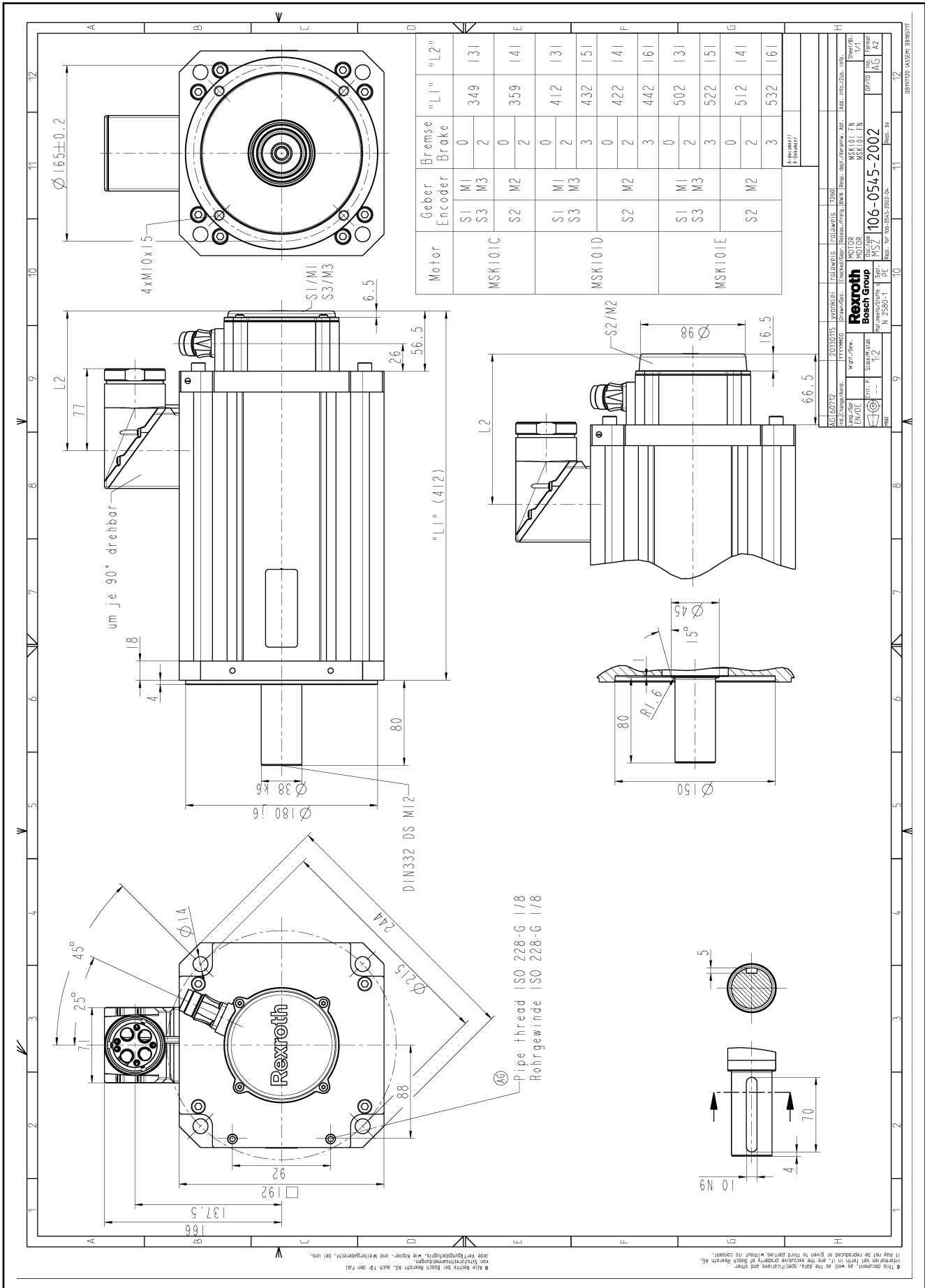

Fig. 5-29: MSK101...FN specification

5.31 MSK101 Specifications fan unit axial

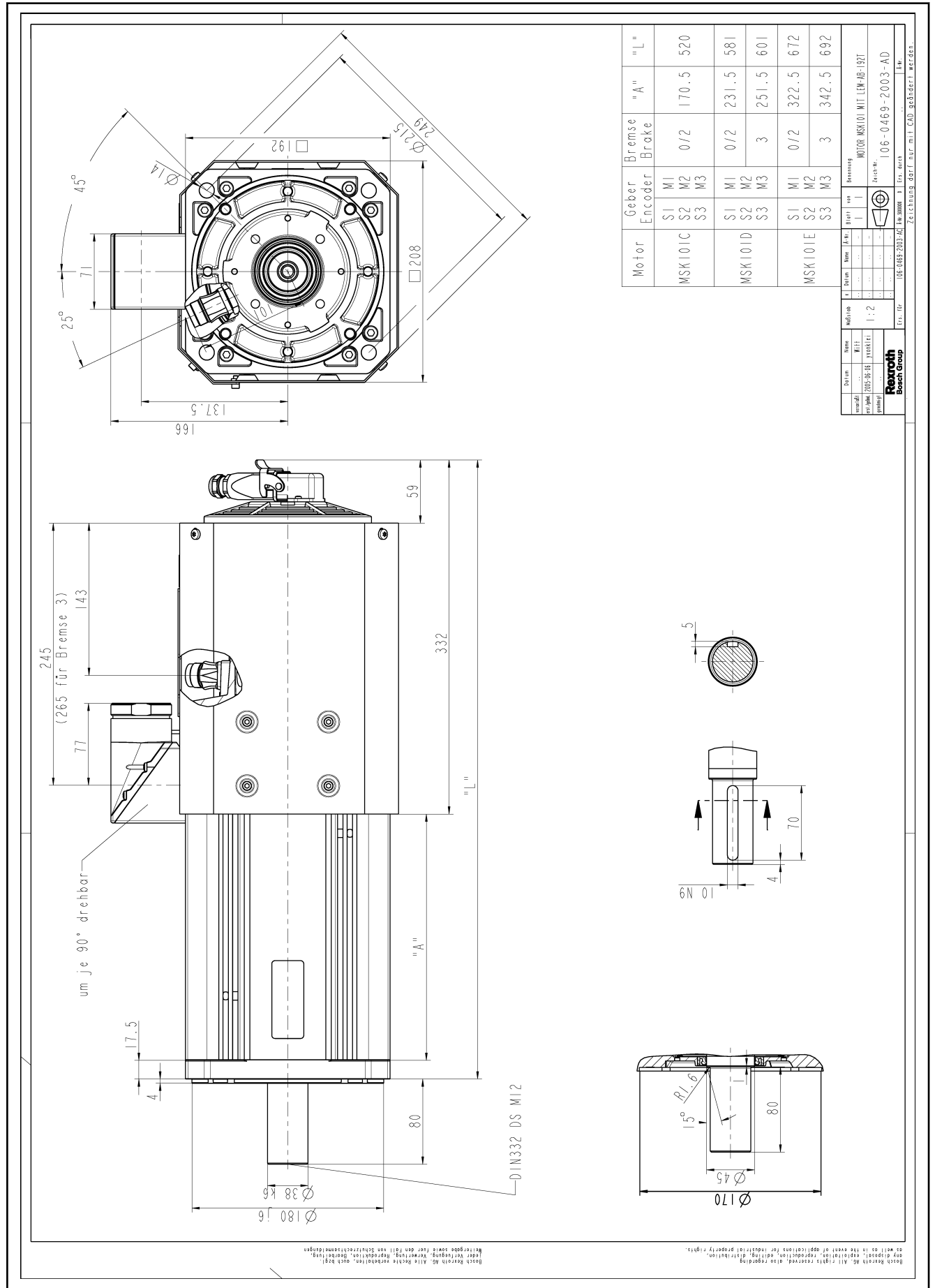

Fig. 5-30: Dimension sheet MSK101 with axial fan unit

Specifications

5.32 MSK101 Specifications radial fan unit

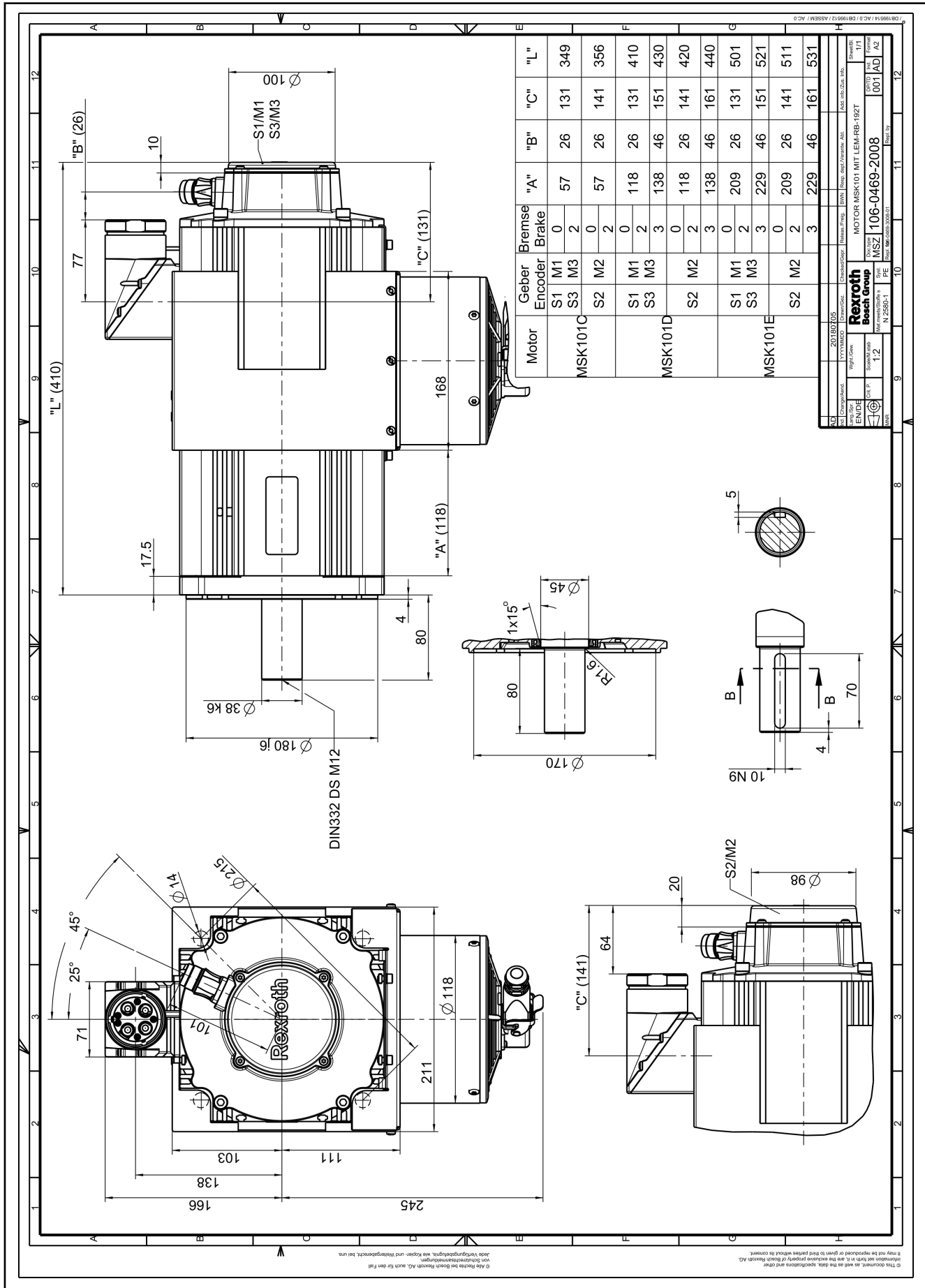

Fig. 5-31: Dimension drawing MSK101 with radial fan unit

5.33 MSK103 Specifications

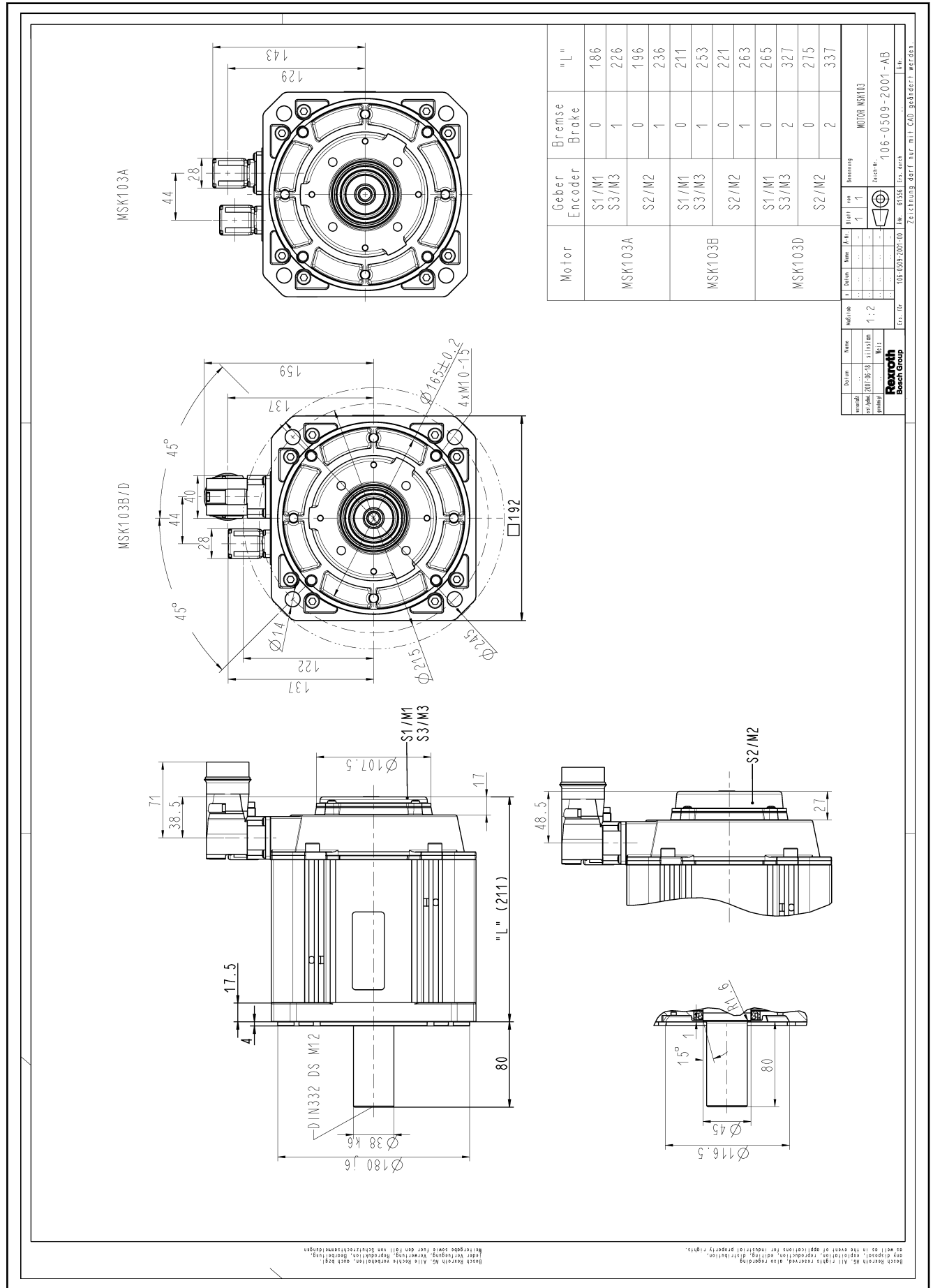

Fig. 5-32: MSK103 specification

Specifications

5.34 MSK131 Specifications

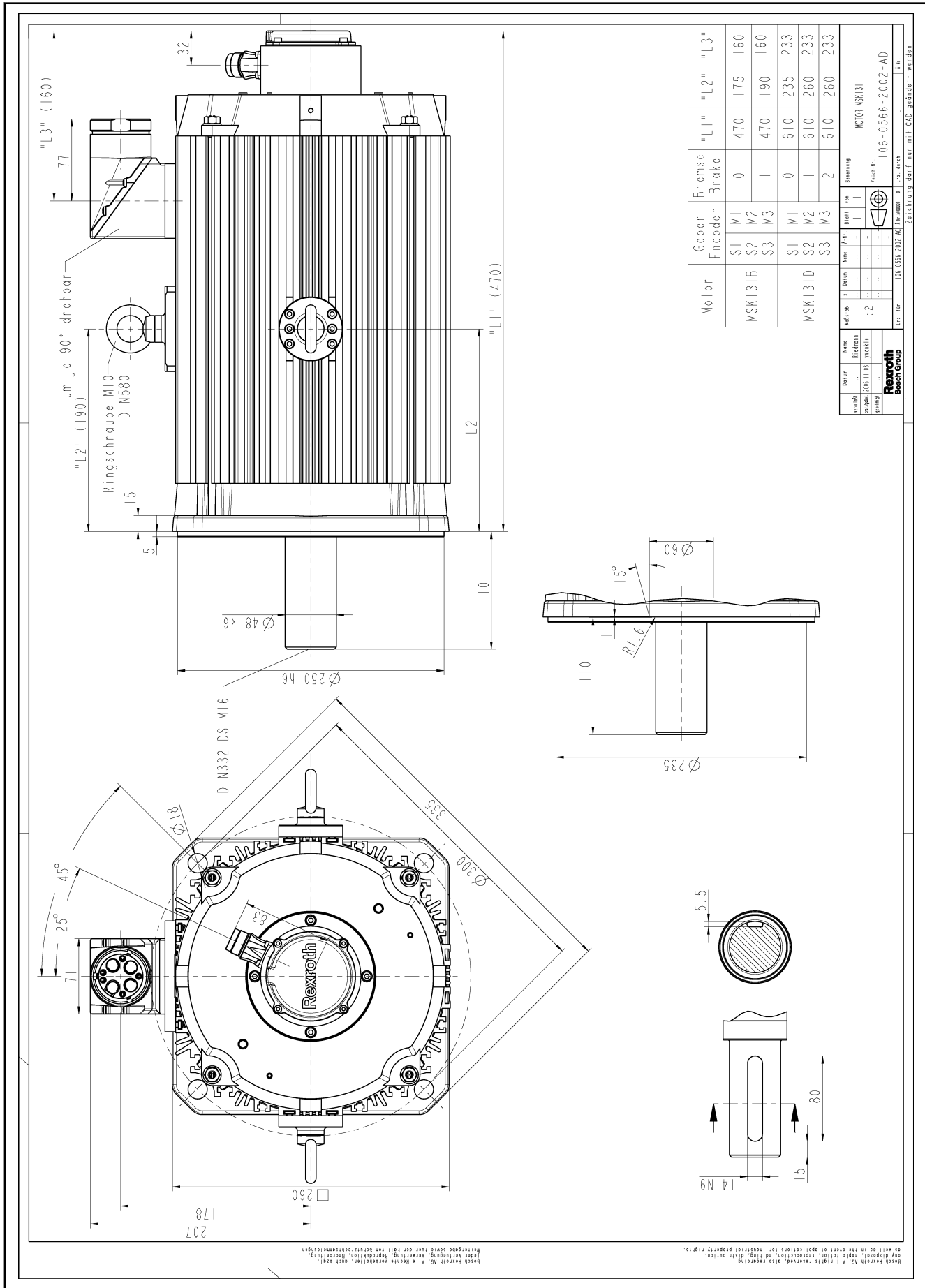

Fig. 5-33: MSK131 specification

Specifications

5.36 MSK133 Specifications

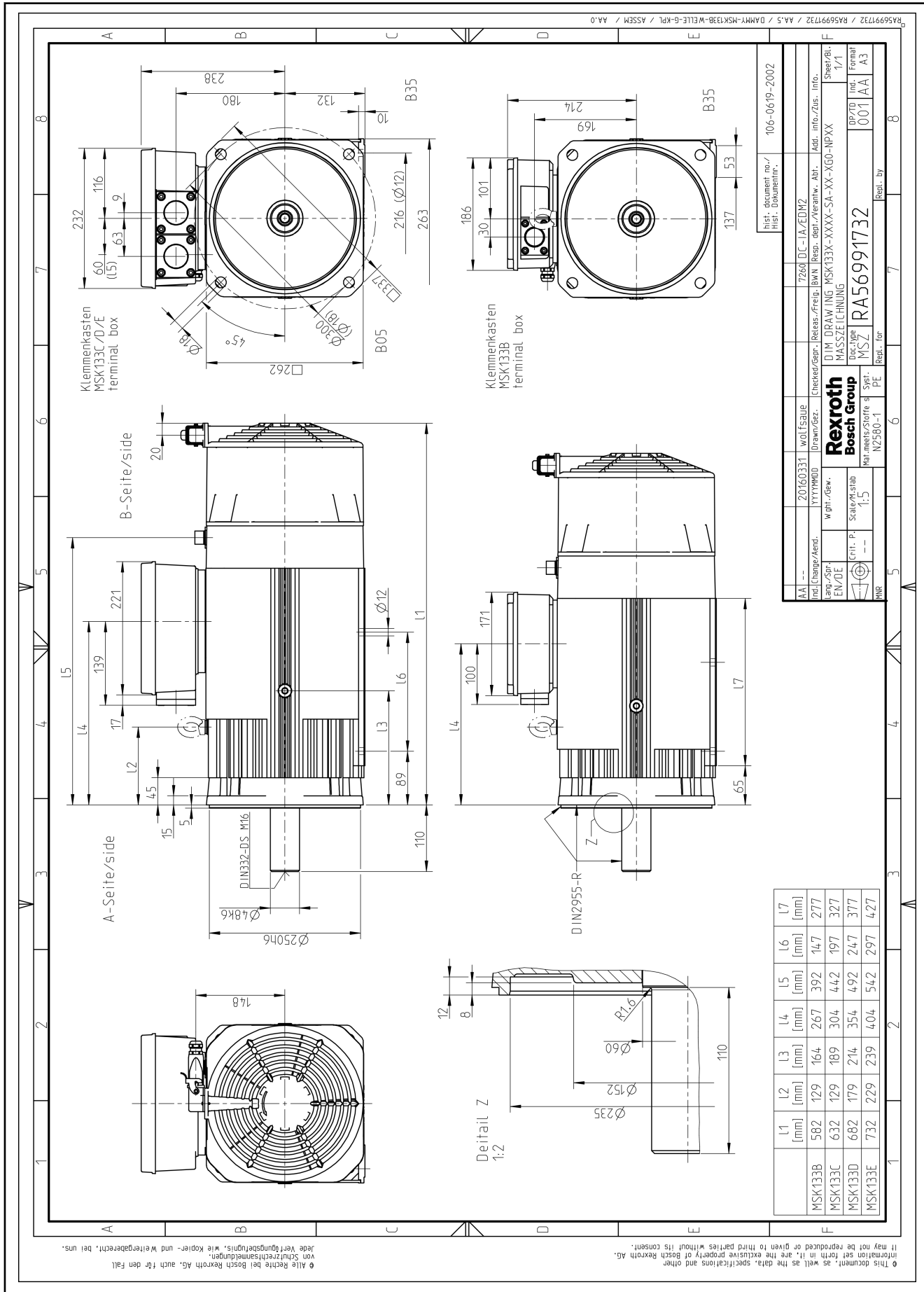

Fig. 5-35: Specifications MSK133

© This document, as well as the data, specifications and other information set forth in it, are the exclusive property of Bosch Rexroth AG. It may not be reproduced or given to third parties without its consent.

© Alle Rechte bei Bosch Rexroth AG, auch für den Fall von Schutzrechtsanmeldungen.

Jede Vervielfältigung, wie Kopier- und Weitergaberecht, bei uns.

5.37 MSK133 Specifications liquid cooling

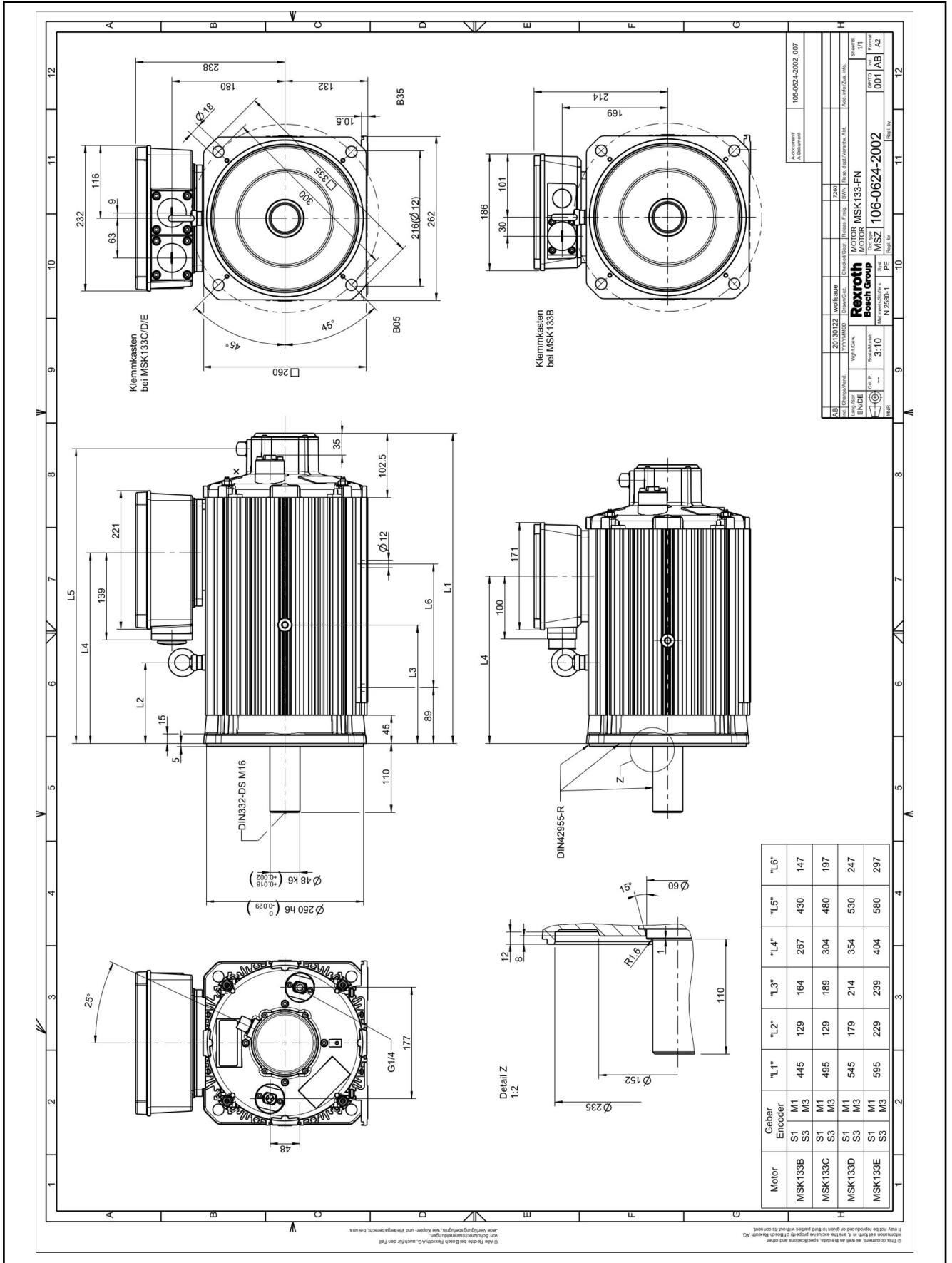

Fig. 5-36: MSK133-_-FN

6 Type code

6.1 MSK type code - structure and description

General information The basis for every order for a Rexroth product is the type code. All available motor variants are clearly described by the type code. The individual type code positions (short text column) and their meaning are described below.



Have your Bosch Rexroth sales partner check the availability of individual options before placing an order.

Product Example: **MSK**-...
MSK three-digit Rexroth specific designation of a servo motors series

Frame size Example: **MSK050**-...
The motor size determines important mechanical motor dimensions and is proportional to the power rating.

Frame length Example: **MSK050B**-...
Within a series, increasing motor frame length is graded by means of code letters in alphabetical order. Frame lengths are e.g. B, C, D and E.

Winding Example: **MSK050B-0300**-...
The four-digit number sequence indicates the rated speed which applies to the respective winding variant.

Cooling type Example: **MSK050B-0300-NN**-...

Option	Design	Note
NN	Natural convection	Fan installation possible
FN	Liquid cooling	Standard connection for cooling lines 1/8"; fan installation not possible
SA	Blowing axial fan	only applicable to MSK133 motors

Tab. 6-1: Cooling types

Encoder Example: **MSK050B-0300-NN-S1**-...
MSK motors are equipped with built-in encoder systems. For controlling the motor speed and/or positioning of the motor, the drive control unit requires the current motor position.

Electrical connection Example: **MSK050B-0300-NN-S1-U**-...

Option	Description
U	Power and encoder connector, rotatable
A	Cable connector, A side
B	Cable connector, B side
L	Cable connector to the left
R	Cable connector to the right
F	Terminal box

Detailed description of the plug connectors see [chapter 8 "Connection technique" on page 191](#)

Tab. 6-2: Electrical connection

Shaft Example: **MSK050B-0300-NN-S1-UG**-...
MSK motors provide the following options to connect the machine elements to be driven to the motor shafts.

Type code

Option	Design	Detail
G	Smooth shaft	With frontal centering hole with "DS" thread according to DIN 332, part 2, edition 05.83
P	Shaft with keyway	Keyway according to DIN 6885, sheet 1, edition 08.68 (details see dimensional drawing)

Tab. 6-3: Output shafts



MSK motors are balanced with key. The corresponding key is not included in the scope of delivery.

Holding brake

Example: MSK050B-0300-NN-S1-UG1-...

MSK motors are optionally available with electrically released holding brakes and different holding torques.

Option	Holding brakes
0	Without holding brake
1, 2, 3	With holding brake The holding torques are specified in the motor type codes.

Tab. 6-4: Holding brakes



The holding brake is not suitable for personal protection and cannot be used as a service brake. Observe the installation and safety instructions for the motor holding brakes in the chapter "Application instructions"!

Design

Example: MSK050B-0300-NN-S1-UG1-**NNNN**

NNNN = standard version

NSNN = standard and Ex version according to equipment group II, categories 3G and 3D according to DIN EN 60079 et seq.

RNNN = version with increased concentricity quality

RSNN = version with increased concentricity quality and Ex version according to equipment group II, categories 3G and 3D according to DIN EN 60079 et seq.

Note

Further necessary information concerning the handling of the type code can be found here. These can be, for example, descriptions of footnotes or information on delivery options.

6.2 MSK030 Type code

Abbreviation column	1	2	3	4	5	6	7	8	9	0	1	2	3	4	5	6	7	8	9	0	1	2	3	4	5	6	7	8	9	0	1	2	3	4	5	6	7	8	9	0											
Example:	M	S	K	0	3	0	C	-	0	9	0	0	-	N	N	-	S	1	-	U	G	0	-	N	N	N	N																								
Product																																																			
MSK	= MSK																																																		
Size																																																			
030	=030																																																		
Lengths																																																			
Lengths	= B, C																																																		
Winding																																																			
MSK030B				= 0900																																															
MSK030C				= 0900																																															
Cooling																																																			
Natural convection				= NN																																															
Encoder ¹⁾																																																			
Optical encoder, Singleturn Hiperface, with 128 signal periods																																																			
Capacitive encoder, Singleturn Hiperface, with 16 signal periods																																																			
Optical encoder, Multiturn absolute Hiperface, with 128 signal periods																																																			
Capacitive encoder, Multiturn absolute Hiperface, with 16 signal periods																																																			
Electrical Connection																																																			
Connector, rotatable 240°																																																			
Shaft																																																			
Smooth shaft with shaft sealing ring (standard)																																																			
Shaft with keyway acc. to DIN 6885-1 with shaft sealing ring																																																			
Holding Brake																																																			
Without holding brake																																																			
Holding brake, electrically-released, 1 Nm																																																			
Other Design																																																			
Standard																																																			
Standard and Ex-design acc. to device group II, categories 3G and 3D acc. to EN 60079 ff																																																			
Remark																																																			
1) Encoder "S3" and "M3" are only available with other design "NNNN"																																																			

Fig. 6-1: MSK030 Type Code

Type code

6.3 MSK040 Type code

Abbreviation- column	1	2	3	4	5	6	7	8	9	0	1	2	3	4	5	6	7	8	9	0	1	2	3	4	5	6	7	8	9	0	1	2	3	4	5	6	7	8	9	0	
Example:	M	S	K	0	4	0	C	-	0	6	0	0	-	N	N	-	S	1	-	U	G	0	-	N	N	N	N														
Product	MSK = MSK																																								
Size	040 = 040																																								
Lengths	Lengths = B, C																																								
Winding	MSK040B = 0450, 0600		MSK040C = 0450, 0600																																						
Cooling	Natural convection = NN																																								
Encoder ¹⁾	Optical encoder, Singleturn Hiperface, with 128 signal periods = S1		Optical encoder, Singleturn EnDat2.1, with 2,048 signal periods = S2		Capacitive encoder, Singleturn Hiperface, with 16 signal periods = S3		Optical encoder, Multiturn absolute Hiperface, with 128 signal periods = M1		Optical encoder, Multiturn absolute EnDat2.1, with 2,048 signal periods = M2		Capacitive encoder, Multiturn absolute Hiperface, with 16 signal periods = M3																														
Electrical Connection	Connector, rotatable 240° = U																																								
Shaft	Smooth shaft with shaft sealing ring (standard) = G		Shaft with keyway acc. to DIN 6885-1 with shaft sealing ring = P																																						
Holding Brake	Without holding brake = 0		Holding brake, electrically-released, 4 Nm = 1																																						
Other Design	Standard = NNNN		Standard and Ex-design acc. to device group II, categories 3G and 3D acc. to EN 60079 ff = NSNN																																						
Remark	1) Encoder "S3" and "M3" are only available with other design "NNNN"																																								

Fig. 6-2: Type code MSK040

Type code

6.5 MSK050 Type code

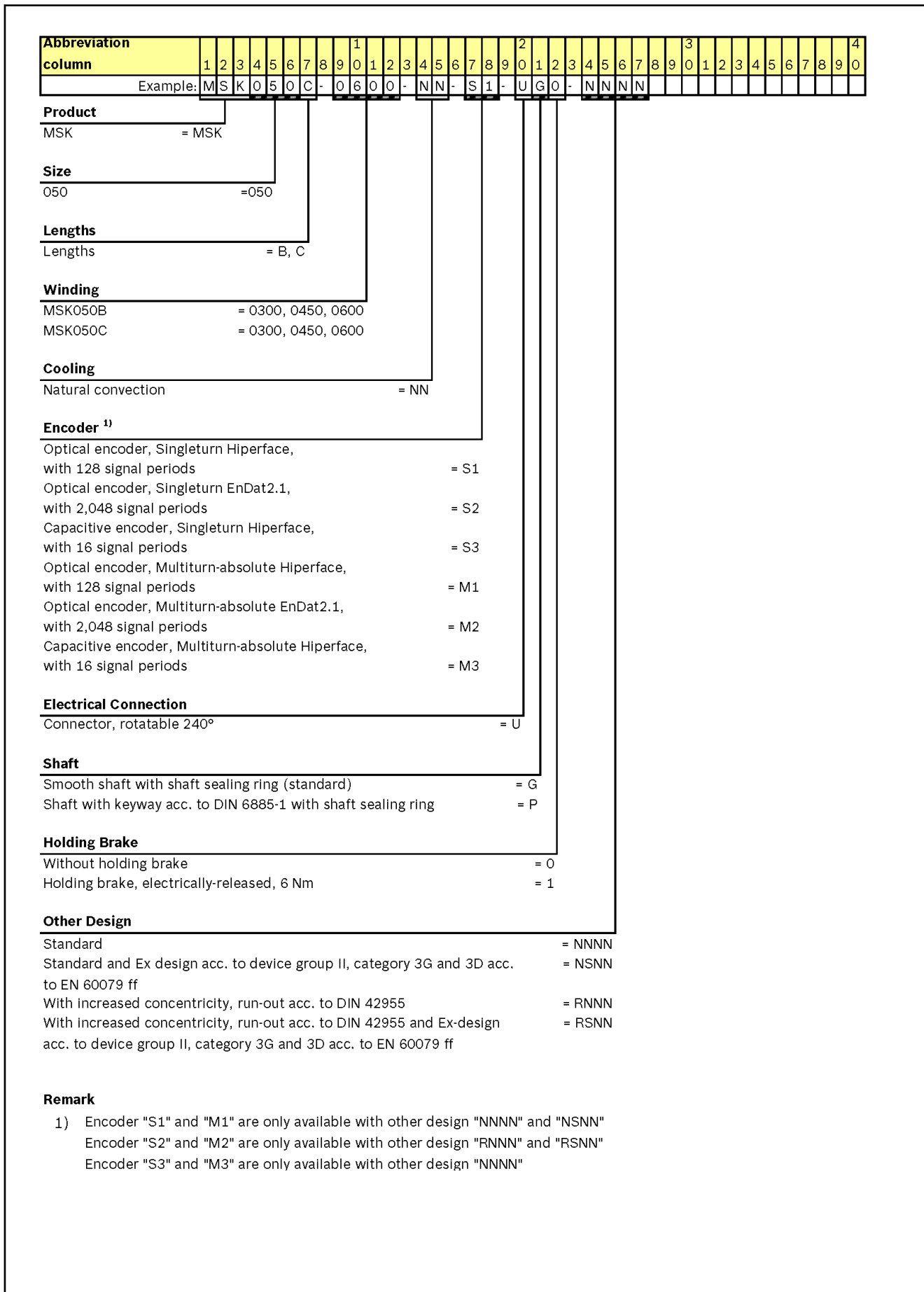

Fig. 6-4: MSK050 type code

6.6 MSK060 Type code

Abbreviation	1	2	3	4	5	6	7	8	9	1	2	3	4	5	6	7	8	9	0	1	2	3	4	5	6	7	8	9	0	1	2	3	4								
Example:	M	S	K	0	6	0	C	-	0	6	0	0	-	N	N	-	S	1	-	U	G	0	-	N	N	N	N														
Product	MSK = MSK																																								
Size	060 = 060																																								
Lengths	Lengths = B, C																																								
Winding	MSK060B = 0300, 0600			MSK060C = 0300, 0600																																					
Cooling	Natural convection = NN																																								
Encoder ¹⁾	Optical encoder, Singleturn Hiperface, with 128 signal periods = S1			Optical encoder, Singleturn EnDat2.1, with 2,048 signal periods = S2		Capacitive encoder, Singleturn Hiperface, with 16 signal periods = S3		Optical encoder, Multiturn-absolute Hiperface, with 128 signal periods = M1		Optical encoder, Multiturn-absolute EnDat2.1, with 2,048 signal periods = M2		Capacitive encoder, Multiturn-absolute Hiperface, with 16 signal periods = M3																													
Electrical Connection	Connector, rotatable 240° = U																																								
Shaft	Smooth shaft with shaft sealing ring (standard) = G			Shaft with keyway acc. to DIN 6885-1 with shaft sealing ring = P																																					
Holding Brake	Without holding brake = 0			Holding brake, electrically-released, 10 Nm = 1																																					
Other Design	Standard = NNNN			Standard and Ex design acc. to device group II, categories 3G and 3D acc. to EN 60079 ff = NSNN		With increased concentricity, run-out acc. to DIN 42955 = RNNN		With increased concentricity, run-out acc. to DIN 42955 and Ex design acc. to device group II, categories 3G and 3D acc. to EN 60079 ff = RSNN																																	
Remark	<p>1) Encoders "S1" and "M1" are only available with other design "NNNN" and "NSNN" Encoders "S2" and "M2" are only available with other design "RNNN" and "RSNN" Encoders "S3" and "M3" are only available with other design "NNNN"</p>																																								

Fig. 6-5: MSK060 type code

Type code

6.7 MSK061 Type code

Abbreviation column	1	2	3	4	5	6	7	8	9	0	1	2	3	4	5	6	7	8	9	0	1	2	3	4	5	6	7	8	9	0	1	2	3	4	5	6	7	8	9	0
Example:	M	S	K	0	6	1	C	-	0	3	0	0	-	N	N	-	S	1	-	U	G	0	-	N	N	N	N	-												
Product	MSK		= MSK																																					
Size	061		=061																																					
Lengths ¹⁾	Length		= B, C																																					
Winding	MSK061B		= 0300																																					
	MSK061C		= 0200, 0300, 0600																																					
Cooling	Natural convection		= NN																																					
Encoder ²⁾	Optical encoder, Singleturn Hiperface, with 128 signal periods		= S1																																					
	Optical encoder, Singleturn EnDat2.1, with 2,048 signal periods		= S2																																					
	Capacitive encoder, Singleturn Hiperface, with 16 signal periods		= S3																																					
	Optical encoder, Multiturn-absolute Hiperface, with 128 signal periods		= M1																																					
	Optical encoder, Multiturn-absolute EnDat2.1, with 2,048 signal periods		= M2																																					
	Capacitive encoder, Multiturn-absolute Hiperface, with 16 signal periods		= M3																																					
Electrical Connection	Connector, rotatable 240°		= U																																					
Shaft	Smooth shaft with shaft sealing ring (standard)		= G																																					
	Shaft with keyway acc. to DIN 6885-1 with shaft sealing ring		= P																																					
Holding Brake	Without holding brake		= 0																																					
	Holding brake, electrically-released, 10 Nm		= 1																																					
Other Design	Standard		= NNNN																																					
	Standard and Ex design acc. to device group II, categories 3G and 3D acc. to EN 60079 ff		= NSNN																																					
	With increased concentricity, run-out acc. to DIN 42955		= RNNN																																					
	With increased concentricity, run-out acc. to DIN 42955 and Ex design acc. to device group II, categories 3G and 3D acc. to EN 60079 ff		= RSNN																																					
Remark																																								
	1) Frame length "B" is only available with encoder "S1", "S3", "M1" or "M3" and other design "NNNN"																																							
	2) Encoder "S1" and "M1" are only available with other design "NNNN" and "NSNN" Encoder "S2" and "M2" are only available with other design "RNNN" and "RSNN" Encoder "S3" and "M3" are only available with other design "NNNN"																																							

Fig. 6-6: MSK061 Type Code

6.8 MSK070 Type code

Abbreviation column	1	2	3	4	5	6	7	8	9	0	1	2	3	4	5	6	7	8	9	0	1	2	3	4	5	6	7	8	9	0	1	2	3	4	5	6	7	8	9	0
Example:	M	S	K	0	7	0	C	-	0	4	5	0	-	N	N	-	S	1	-	U	G	0	-	N	N	N	N													
Product	MSK = MSK																																							
Size	070 = 070																																							
Lengths	Lengths = C, D, E																																							
Winding	MSK070C = 0150, 0300, 0450																																							
	MSK070D = 0150, 0300, 0450																																							
	MSK070E = 0150, 0300, 0450																																							
Cooling	Natural convection = NN																																							
Encoder ¹⁾																																								
	Optical encoder, Singleturn Hiperface, with 128 signal periods = S1																																							
	Optical encoder, Singleturn EnDat2.1, with 2,048 signal periods = S2																																							
	Capacitive encoder, Singleturn Hiperface, with 16 signal periods = S3																																							
	Optical encoder, Multiturn-absolute Hiperface, with 128 signal periods = M1																																							
	Optical encoder, Multiturn-absolute EnDat2.1, with 2,048 signal periods = M2																																							
	Capacitive encoder, Multiturn-absolute Hiperface, with 16 signal periods = M3																																							
Electrical Connection	Connector, rotatable 240° = U																																							
Shaft																																								
	Smooth shaft with shaft sealing ring (standard) = G																																							
	Shaft with keyway acc. to DIN 6885-1 with shaft sealing ring = P																																							
Holding Brake																																								
	Without holding brake = 0																																							
	Holding brake, electrically-released, 23 Nm = 1																																							
Other Design																																								
	Standard = NNNN																																							
	Standard and Ex design acc. to device group II, categories 3G and 3D acc. to EN 60079 ff = NSNN																																							
	With increased concentricity, run-out according to DIN 42955 = RNNN																																							
	With increased concentricity, run-out according to DIN 42955 and Ex design acc. to device group II, categories 3G and 3D acc. to EN 60079 ff = RSNN																																							
Remark																																								
	1) Encoder "S1" and "M1" are only available with other design "NNNN" and "NSNN"																																							
	Encoder "S2" and "M2" are only available with other design "RNNN" and "RSNN"																																							
	Encoder "S3" and "M3" are only available with other design "NNNN"																																							

Fig. 6-7: MSK070 type code

Type code

6.9 MSK071 Type code

Abbreviation	1	2	3	4	5	6	7	8	9	0	1	2	3	4	5	6	7	8	9	0	1	2	3	4	5	6	7	8	9	0	1	2	3	4	5	6	7	8	9	0					
Example:	M	S	K	0	7	1	D	-	0	3	0	0	-	N	N	-	S	1	-	U	G	0	-	N	N	N	N																		
Product	MSK																																												
	= MSK																																												
Size	071																																												
	=071																																												
Lengths	Frame lengths																																												
	= C, D, E																																												
Winding	MSK071C																																												
	= 0200, 0300, 0450																																												
	MSK071D																																												
	= 0200, 0300, 0450																																												
	MSK071E																																												
	= 0200, 0300, 0450																																												
Cooling	Liquid cooling ¹⁾																																												
	= FN																																												
	Natural convection																																												
	= NN																																												
Encoder ²⁾	Optical encoder, Singleturn Hiperface, with 128 signal periods																																												
	= S1																																												
	Optical encoder, Singleturn EnDat2.1, with 2,048 signal periods																																												
	= S2																																												
	Capacitive encoder, Singleturn Hiperface, with 16 signal periods																																												
	= S3																																												
	Optical encoder, Multiturn-absolute Hiperface, with 128 signal periods																																												
	= M1																																												
	Optical encoder, Multiturn-absolute EnDat2.1, with 2,048 signal periods																																												
	= M2																																												
	Capacitive encoder, Multiturn-absolute Hiperface, with 16 signal periods																																												
	= M3																																												
Electrical Connection	Connector, rotatable 240°																																												
	= U																																												
Shaft	Smooth shaft with shaft sealing ring (standard)																																												
	= G																																												
	Shaft with keyway acc. to DIN 6885-1 with shaft sealing ring																																												
	= P																																												
Holding Brake	Without holding brake																																												
	= 0																																												
	Holding brake, electrically-released, 23 Nm																																												
	= 1																																												
	Holding brake, electrically-released, 30 Nm																																												
	= 2																																												
Other Design	Standard																																												
	= NNNN																																												
	Standard and Ex design acc. to device group II, categories 3G and 3D acc. to EN 60079 ff																																												
	= NSNN																																												
	With increased concentricity, run-out according to DIN 42955																																												
	= RNNN																																												
	With increased concentricity, run-out acc. to DIN 42955 and Ex design acc. to device group II, categories 3G and 3D acc. to EN 60079 ff																																												
	= RSNN																																												
Remark	1) Cooling mode "FN" is only available with holding brakes "0" and "2" and other design "NNNN" and "RNNN"																																												
	2) Encoder "S1" and "M1" are only available with other design "NNNN" and "NSNN"																																												
	Encoder "S2" and "M2" are only available with other design "RNNN" and "RSNN"																																												
	Encoder "S3" and "M3" are only available with other design "NNNN"																																												

Fig. 6-8: Type code MSK071

6.10 MSK075 Type code

Abbreviation column	1	2	3	4	5	6	7	8	9	10	11	12	13	14	15	16	17	18	19	20	21	22	23	24	25	26	27	28	29	30	31	32	33	34	35	36	37	38	39	40																											
Example:	M	S	K	0	7	5	E	-	0	2	0	0	-	N	N	-	S	1	-	U	G	0	-	N	N	N	N																																								
Product	MSK = MSK																																																																		
Size	075 =075																																																																		
Lengths	Lengths = C, D, E																																																																		
Winding	MSK075C = 0200, 0300, 0450				MSK075D = 0200, 0300, 0450				MSK075E = 0200, 0300, 0450																																																										
Cooling	Liquid cooling ¹⁾ = FN																	Natural convection = NN																																																	
Encoder ²⁾	Optical encoder, Singleturn Hiperface, with 128 signal periods = S1																	Optical encoder, Singleturn EnDat2.1, with 2,048 signal periods = S2										Capacitive encoder, Singleturn Hiperface, with 16 signal periods = S3										Optical encoder, Multiturn-absolute Hiperface, with 128 signal periods = M1										Optical encoder, Multiturn-absolute EnDat2.1, with 2,048 signal periods = M2										Capacitive encoder, Multiturn-absolute Hiperface, with 16 signal periods = M3									
Elektrical Connection	Connector, rotatable 240° = U																																																																		
Shaft	Smooth shaft with shaft sealing ring (standard) = G																	Shaft with keyway acc. to DIN 6885-1 with shaft sealing ring = P																																																	
Holding Brake	Without holding brake = 0																	Holding brake, electrically-released, 23 Nm = 1																	Holding brake, electrically-released, 30 Nm = 2																																
Other Design	Standard = NNNN																	With increased concentricity, run-out according to DIN 42955 = RNNN																																																	
Remark	1) Cooling mode "FN" is only available with holding brake "0" and "2" and other design "NNNN" and "RNNN" 2) Encoder "S1" and "M1" are only available with other design "NNNN" and "NSNN" Encoder "S2" and "M2" are only available with other design "RNNN" and "RSNN" Encoder "S3" and "M3" are only available with other design "NNNN"																																																																		

Fig. 6-9: MSK075 Type Code

Type code

6.11 MSK076 Type code

Abbreviation	1	2	3	4	5	6	7	8	9	0	1	2	3	4	5	6	7	8	9	0	1	2	3	4	5	6	7	8	9	0	1	2	3	4	5	6	7	8	9	0
Example:	M	S	K	0	7	6	C	-	0	3	0	0	-	N	N	-	S	1	-	U	G	0	-	N	N	N	N													
Product	MSK = MSK																																							
Size	076 = 076																																							
Length	Length = C																																							
Winding	MSK076C = 0300, 0450																																							
Cooling	Natural convection = NN																																							
Encoder ¹⁾																																								
Optical encoder, Singleturn Hiperface, with 128 signal periods												= S1																												
Optical encoder, Singleturn EnDat2.1, with 2,048 signal periods												= S2																												
Capacitive encoder, Singleturn Hiperface, with 16 signal periods												= S3																												
Optical encoder, Multiturn absolute Hiperface, with 128 signal periods												= M1																												
Optical encoder, Multiturn absolute EnDat2.1, with 2,048 signal periods												= M2																												
Capacitive encoder, Multiturn absolute Hiperface, with 16 signal periods												= M3																												
Electrical Connection																																								
Connector, rotatable 240°																					= U																			
Shaft																																								
Smooth shaft with shaft sealing ring (standard)																					= G																			
Shaft with keyway acc. to DIN 6885-1 with shaft sealing ring																					= P																			
Holding Brake																																								
Without holding brake																					= 0																			
Holding brake, electrically-released, 11 Nm																					= 1																			
Other Design																																								
Standard																					= NNNN																			
Standard and Ex-design acc. to device group II, categories 3G and 3D acc. to DIN EN 60079 ff																					= NSNN																			
With increased concentricity, run-out acc. to DIN 42955																					= RNNN																			
With increased concentricity, run-out acc. to DIN 42955 and Ex-design acc. to device group II, categories 3G and 3D acc. to DIN EN 60079 ff																					= NSNN																			
Remark																																								
1) Encoders "S1" and "M1" are only available with other design "NNNN" and "NSNN"																																								
Encoders "S2" and "M2" are only available with other design "RNNN" and "RSNN"																																								
Encoders "S3" and "M3" are only available with other design "NNNN"																																								

Fig. 6-10: MSK076 Type Code

6.12 MSK100 Type code

Abbreviation column	1	2	3	4	5	6	7	8	9	0	1	2	3	4	5	6	7	8	9	0	1	2	3	4	5	6	7	8	9	0	1	2	3	4		
Example:	M	S	K	1	0	0	B	-	0	2	0	0	-	N	N	-	S	1	-	A	G	0	-	N	N	N	N									
Product	MSK				= MSK																															
Size	100				=100																															
Lengths ¹⁾	Frame lengths				= A, B, C, D																															
Windings ²⁾	MSK100A				= 0200, 0300, 0450																															
	MSK100B				= 0200, 0300, 0400, 0450																															
	MSK100C				= 0200, 0300, 0301, 0450 ¹⁾																															
	MSK100D				= 0200, 0300, 0350																															
Cooling	Natural convection				= NN																															
Encoder ³⁾	Optical encoder, Singleturn Hiperface, with 128 signal periods				= S1																															
	Optical encoder, Singleturn EnDat2.1, with 2,048 signal periods				= S2																															
	Capacitive encoder, Singleturn Hiperface, with 16 signal periods				= S3																															
	Optical encoder, Multiturn absolute Hiperface, with 128 signal periods				= M1																															
	Optical encoder, Multiturn absolute EnDat2.1, with 2,048 signal periods				= M2																															
	Capacitive encoder, Multiturn absolute Hiperface, with 16 signal periods				= M3																															
Electrical Connection ⁴⁾	Connector, A-side				= A																															
	Connector, B-side				= B																															
	Connector, left				= L																															
	Connector, right				= R																															
Shaft	Smooth shaft with shaft sealing ring (standard)				= G																															
	Shaft with keywas acc. to DIN 6885-1 with shaft sealing ring				= P																															
Holding Brake ⁵⁾	Without holding brake				= 0																															
	Holding brake, electrically-released, 32 Nm				= 1																															
	Holding brake, electrically-released, 70 Nm				= 2																															
Other Design ⁶⁾	Standard				= NNNN																															
	Standard and Ex-design acc. to device group II, categories 3G and 3D acc. to DIN EN 60079 ff				= NSNN																															
	With increased concentricity, run-out acc. to DIN 42955				= RNNN																															
	With increased concentricity, run-out acc. to DIN 42955 and Ex-design acc. to device group II, categories 3G and 3D acc. to DIN EN 60079 ff				= NSNN																															

Fig. 6-11: MSK100 type code (page 1)

Type code

Abbreviation column	1	2	3	4	5	6	7	8	9	0	1	2	3	4	5	6	7	8	9	0	1	2	3	4	5	6	7	8	9	0	1	2	3	4	5	6	7	8	9	0	
Example:	M	S	K	1	0	0	B	-	0	2	0	0	-	N	N	-	S	1	-	A	G	0	-	N	N	N	N														

Remark

- 1) Length "C" and winding "0300" are only available with other design "NNNN" and "RNNN"
- 2) Winding "0450" is only available with other design "NNNN" and "RNNN"
Winding "0301" is only available with other design "NSNN" and "RSNN"
- 3) Encoder "S1" and "M1" are only available with other design "NNNN" and "NSNN"
Encoder "S2" and "M2" are only available with other design "RNNN" and "RSNN"
Encoder "S3" and "M3" are only available with other design "NNNN"
- 4) View from front onto output shaft
- 5) Holding brake "1" is only available with lengths "A" and "B"
Holding brake "2" is not available with length "A"

6.13 MSK101 Type code

Abbreviation	1	2	3	4	5	6	7	8	9	1	2	3	4	5	6	7	8	9	2	1	2	3	4	5	6	7	8	9	3	1	2	3	4	5	6	7	8	9	4
column	1	2	3	4	5	6	7	8	9	1	2	3	4	5	6	7	8	9	1	2	3	4	5	6	7	8	9	1	2	3	4	5	6	7	8	9	1		
Example:	M	S	K	1	0	1	D	-	0	2	0	0	-	N	N	-	S	1	-	A	G	0	-	N	N	N	N	-	-	-	-	-	-	-	-	-	0		
Product																																							
MSK																			=	MSK																			
Size																																							
101																			=	101																			
Lengths ¹⁾																																							
Lengths																			=	C, D, E																			
Winding ²⁾																																							
MSK101C																			=	0200, 0300, 0301, 0450																			
MSK101D																			=	0200, 0300, 0301, 0450																			
MSK101E																			=	0200, 0300, 0450																			
Cooling																																							
Natural convection																			=	NN																			
Liquid cooling																			=	FN																			
Encoder ³⁾																																							
Optical encoder, Singleturn Hiperface, with 128 signal periods																			=	S1																			
Optical encoder, Singleturn EnDat2.1, with 2,048 signal periods																			=	S2																			
Capacitive encoder, Singleturn Hiperface, with 16 signal periods																			=	S3																			
Optical encoder, Multiturn absolute Hiperface, with 128 signal periods																			=	M1																			
Optical encoder, Multiturn absolute EnDat2.1, with 2,048 signal periods																			=	M2																			
Capacitive encoder, Multiturn absolute Hiperface, with 16 signal periods																			=	M3																			
Electrical Connection ⁴⁾																																							
Connector, A-side																			=	A																			
Connector, B-side																			=	B																			
Connector, left																			=	L																			
Connector, right																			=	R																			
Shaft																																							
Smooth shaft with shaft sealing ring (standard)																			=	G																			
Smooth with keyway acc. to DIN 6885-1 with shaft sealing ring																			=	P																			
Holding Brake ⁵⁾																																							
Without holding brake																			=	0																			
Holding brake, electrically-released, 70 Nm																			=	2																			
Holding brake, electrically-released, 120 Nm																			=	3																			
Other Design ⁶⁾																																							
Standard																			=	NNNN																			
Standard and Ex-design acc. to device group II, categories 3G and 3D acc. to DIN EN 60079 ff																			=	NSNN																			
With increased concentricity, run-out acc. to DIN 42955																			=	RNNN																			
With increased concentricity, run-out acc. to DIN 42955 and Ex-design acc. to device group II, categories 3G and 3D acc. to DIN EN 60079 ff																			=	NSNN																			

Fig. 6-13: MSK101 type code (page 1)

Type code

Abbreviation	1									2									3									4												
column	1	2	3	4	5	6	7	8	9	0	1	2	3	4	5	6	7	8	9	0	1	2	3	4	5	6	7	8	9	0	1	2	3	4	5	6	7	8	9	0
Example:	M	S	K	1	0	1	D	-	0	2	0	0	-	N	N	-	S	1	-	A	G	0	-	N	N	N	N													

Remark

- 1) Frame length "E" is only available with other design "NNNN" and "RNNN"
- 2) Windings "0300" and "0450" is only available with other design "NNNN" and "RNNN"
- 3) Encoders "S1" and "M1" are only available with other design "NNNN" and "NSNN"
Encoders "S2" and "M2" are only available with other design "RNNN" and "RSNN"
Encoders "S3" and "M3" are only available with other design "NNNN"
- 4) View from the front onto the output shaft
- 5) Holding brake "3" is not available with frame length "C"
- 6) Other designs "NSNN" and "RSNN" are not available with cooling mode "FN" and holding brake "3"

Fig. 6-14: MSK101 type code (page 2)

6.14 MSK103 Type code

Abbreviation	1	2	3	4	5	6	7	8	9	1	2	3	4	5	6	7	8	9	2	1	2	3	4	5	6	7	8	9	3	1	2	3	4	5	6	7	8	9	4
Example:	M	S	K	1	0	3	B	-	0	3	0	0	-	N	N	-	S	1	-	U	G	0	-	N	N	N	N												
Product																																							
MSK	= MSK																																						
Size																																							
103	=103																																						
Lengths																																							
Lengths	= A, B, D																																						
Winding ¹⁾																																							
MSK103A	= 0300																																						
MSK103B	= 0300																																						
MSK103D	= 0300																																						
Cooling																																							
Natural convection	= NN																																						
Encoder																																							
Optical encoder, Singleturn Hiperface, with 128 signal periods																	= S1																						
Optical encoder, Singleturn EnDat2.1, with 2,048 signal periods																	= S2																						
Capacitive encoder, Singleturn Hiperface, with 16 signal periods																	= S3																						
Optical encoder, Multiturn absolute Hiperface, with 128 signal periods																	= M1																						
Optical encoder, Multiturn absolute EnDat2.1, with 2,048 signal periods																	= M2																						
Capacitive encoder, Multiturn absolute Hiperface, with 16 signal periods																	= M3																						
Electrical Connection																																							
Connector, rotatable 240°																	= U																						
Shaft																																							
Smooth shaft with shaft sealing ring (standard)																	= G																						
Holding Brake																																							
Without holding brake																	= 0																						
Holding brake, electrically-released, 33 Nm																	= 1																						
Holding brake, electrically-released, 60 Nm																	= 2																						
Other Design																																							
Standard																	= NNNN																						
With increased concentricity, run-out acc. to DIN 42955																	= RNNN																						
Remark																																							
1) Length "A" is only available with other design "NNNN"																																							
2) Encoders "S1", "S3", "M1" and "M3" are only available with other design "NNNN"																																							
Encoder "S2" and "M2" are only available with other design "RNNN"																																							
3) Holding brake "1" is only available with lengths "A" and "B"																																							
Holding brake "2" is only available with length "D"																																							

Fig. 6-15: MSK103 Type Code

7 Accessories

7.1 Transmission

Standard motors The transmissions of the series

- GTM
- GTE

are optimally matched to MSK motors. The technical data and the various transmission ratios are described in detailed documentation.

The product documentation of the transmissions can be requested with the following order designations from your responsible sales partner.

DOK-GEAR-GTE*****-PRxx-EN-P**

DOK-GEAR-GTM*****-PRxx-EN-P**

Follow the instructions below:

⚠ CAUTION

Motor damage by intrusion of liquid!

Pending liquids (e.g. cooling lubricants, gearbox oil, etc.) at the drive shaft are inadmissible.

When installing gearboxes please use gearboxes with closed (oil-proof) lubrication system only. Gearbox oil should not be in permanent contact with the shaft sealing ring of the motors.

Attachment of transmissions on motors

If transmissions are attached to motors, the thermal coupling of the motors to the machine or system design changes. Depending on the type of transmission, the amount of heat generated at the transmission varies. In any case, the heat dissipation of the motor via the flange is reduced when the transmission is attached. This must be taken into account when planning the system. In order not to thermally overload motors when using transmissions, it is necessary to reduce the specified performance data.

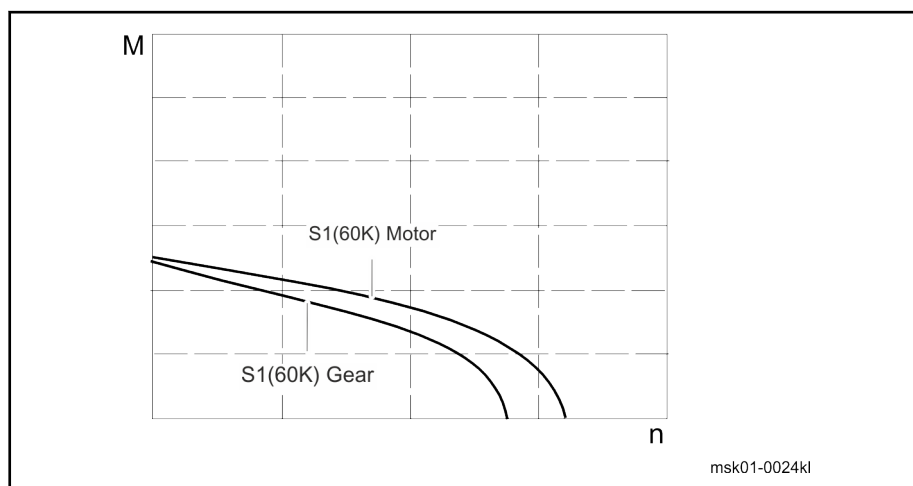

S1(60K) motor Continuous operating characteristic curves S1 motor
S1(60K) gear Continuous operating characteristic curves S1 motor with transmission attachment

Fig. 7-1: S1 characteristic curve transmission

Accessories



The torques specified in the motor characteristics must be reduced by approx. **20-30%** when attaching transmissions.

Observe all other notes and requirements in the documentation for the transmissions used.

7.2 Fan units for MSK motors

7.2.1 Fan units area of application

MSK motors from size 060 can be equipped with fan units. The LEM fan units can be ordered as accessory kits. For certain motors, the fan units can be supplied assembled ex works. Fan units are intended for an attachment to motors in applications with high repetition frequencies or continuous operation.

NOTICE

Damage to property due to improper application of motors with fan units

Motors with mounted fan units are not suited for applications with continuous shock load, e.g. pressing, squeezing, chargers, ...

In such a case, use motors with bigger performance without fan units .

The following designs are available.

Axial

For applications requiring the slimmest possible design.

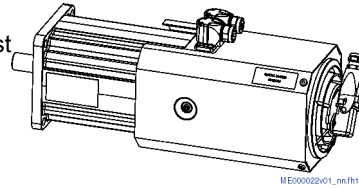

Radial

For applications requiring the shortest possible design.

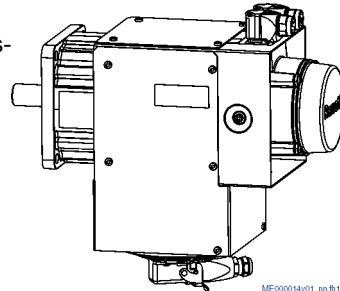

7.2.2 Fan unit type key

Abbreviation column	1	2	3	4	5	6	7	8	9	0	1	2	3	4	5	6	7	8	9	0	1	2	3	4	5	6	7	8	9	0	1	2	3	4	5	6	7	8	9	0	4					
Example:	L	E	M	-	A	B	-	1	9	2	T	-	2	1	-	N	N	N	N																											
Type	LEM = LEM																																													
Ventilation mode					Axial = A		Radial = R ²⁾																																							
Ventilation direction					blowing = B																																									
Flange dimension¹⁾					116 mm = 116		140 mm = 140		192 mm = 192 ²⁾		260 mm = 260																																			
Design											Standard = N		Thermal protection = T																																	
Connection voltage															1 x AC 115 V, 60 Hz = 1		1 x AC 230 V, 50/60 Hz = 2		3 x AC 400 ... 480 V, 50/60 Hz = 3																											
Electrical connection																					1 x AC = 1		3 x AC = 2																							
Other design																																														
Remark																																														
1)	Flange dimension "116", "140" and "192" is only available in design "T", connection voltage "1" and "2" and electrical connection "1"																																													
	Flange dimension "260" is only available with ventilation mode "A", design "N", connection voltage "3" and electrical connection "2"																																													
2)	Other design „NNNA“ is only available with ventilation mode „R“ and flange dimension „192“																																													

Fig. 7-2: Type key fan units LEM for MSK motors

Accessories

7.2.3 Fan unit technical data

Designation	Symbol	Unit	LEM- AB-116T-11- NNNN	LEM- AB-116T-21- NNNN	LEM- RB-116T-11- NNNN	LEM- RB-116T-21- NNNN
Voltage type		-	1~ AC			
Nominal frequency	f_1	Hz	60	50	60	50
Nominal voltage	$U_{1,f1}$	V	115	230	115	230
Fan current	$I_{1,f1}$	A	0.42	0.19	0.42	0.19
Power consumption	$S_{1,f1}$	VA	48.00	44.00	48.00	44.00
Nominal frequency	f_2	Hz	-	60	-	60
Nominal voltage	$U_{1,f2}$	V	-	230	-	230
Fan current	$I_{1,f2}$	A	-	0.17	-	0.17
Power consumption	$S_{1,f2}$	VA	-	39.00	-	39.00
Protection class (EN 60034-5)	-	-	IP65			
Thermal class (EN 60034-1)	T.CL.	-	105			
Thermal protection ¹⁾	-	-	TPF			
Air flow direction		-	blowing			
Mass	m	kg	2.6		3.2	

Last amended: 2014-04-30

1) Thermo protected fan (UL: self protected); no circuit with external motor protection necessary

Tab. 7-1: Data sheet fan size 116

Designation	Symbol	Unit	LEM- AB-140T-11- NNNN	LEM- AB-140T-21- NNNN	LEM- RB-140T-11- NNNN	LEM- RB-140T-21- NNNN
Voltage type		-	1~ AC			
Nominal frequency	f_1	Hz	60	50	60	50
Nominal voltage	$U_{1,f1}$	V	115	230	115	230
Fan current	$I_{1,f1}$	A	0.44	0.20	0.44	0.20
Power consumption	$S_{1,f1}$	VA	51.00	46.00	51.00	46.00
Nominal frequency	f_2	Hz	-	60	-	60
Nominal voltage	$U_{1,f2}$	V	-	230	-	230
Fan current	$I_{1,f2}$	A	-	0.18	-	0.18
Power consumption	$S_{1,f2}$	VA	-	41.00	-	41.00
Protection class (EN 60034-5)	-	-	IP65			
Thermal class (EN 60034-1)	T.CL.	-	105			
Thermal protection ¹⁾	-	-	TPF			
Air flow direction		-	blowing			
Mass	m	kg	3.2		4.0	

Last amended: 2014-04-30

1) Thermo protected fan (UL: self protected); no circuit with external motor protection necessary

Tab. 7-2: Data sheet fan size 140

Designation	Symbol	Unit	LEM-AB-192T-11-NNNN	LEM-AB-192T-21-NNNN	LEM-RB-192T-11-NNNN LEM-RB-192T-11-NNNA	LEM-RB-192T-21-NNNN LEM-RB-192T-21-NNNA
Voltage type		-	1~ AC			
Nominal frequency	f_1	Hz	60	50	60	50
Nominal voltage	$U_{1,f1}$	V	115	230	115	230
Fan current	$I_{1,f1}$	A	0.48	0.21	0.48	0.21
Power consumption	$S_{1,f1}$	VA	55.00	48.00	55.00	48.00
Nominal frequency	f_2	Hz	-	60	-	60
Nominal voltage	$U_{1,f2}$	V	-	230	-	230
Fan current	$I_{1,f2}$	A	-	0.20	-	0.20
Power consumption	$S_{1,f2}$	VA	-	46.00	-	46.00
Protection class (EN 60034-5)	-	-	IP65			
Thermal class (EN 60034-1)	T.CL.	-	105			
Thermal protection ¹⁾	-	-	TPF			
Air flow direction		-	blowing			
Mass	m	kg	4.3		3.8	
Last amended: 2014-04-30						

1) Thermo protected fan (UL: self protected); no circuit with external motor protection necessary

Tab. 7-3: Data sheet fan frame size 192

Designation	Symbol	Unit	LEM-AB-260N-32-NNNN
Voltage type		-	3~ AC
Nominal frequency	f_1	Hz	50
Nominal voltage	$U_{1,f1}$	V	400
Fan current	$I_{1,f1}$	A	0.13
Power consumption	$S_{1,f1}$	VA	90.00
Nominal frequency	f_2	Hz	60
Nominal voltage	$U_{1,f2}$	V	480
Fan current	$I_{1,f2}$	A	0.13
Power consumption	$S_{1,f2}$	VA	110.00
Protection class (EN 60034-5)	-	-	IP65
Thermal class (EN 60034-1)	T.CL.	-	105
Thermal protection ¹⁾	-	-	*
Air flow direction		-	blowing
Mass	m	kg	8.0
Last amended: 2014-04-17			

1) Thermo protected fan (UL: self protected); no circuit with external motor protection necessary

Tab. 7-4: Data sheet fan size 260

Accessories

7.2.4 Fan unit selection table

Refer to the following table for the fan unit for the required motor type.

Motor	LEM- AB-116T-...- NNNN	LEM- RB-116T-...- NNNN	LEM- AB-140T-...- NNNN	LEM- RB-140T-...- NNNN	LEM- AB-192T-...- NNNN	LEM- RB-192T-...- NNNN LEM- RB-192T-...- NNNA	LEM- AB-260N-...- NNNN
MSK060B-...-NN-...0-....	-	-	-	-	-	-	-
MSK060B-...-NN-...1-....	-	-	-	-	-	-	-
MSK060C-...-NN-...0-....	■	□	-	-	-	-	-
MSK060C-...-NN-...1-....	■	■	-	-	-	-	-
MSK061B-...-NN-...0-....	-	-	-	-	-	-	-
MSK061B-...-NN-...1-....	-	-	-	-	-	-	-
MSK061C-...-NN-...0-....	■	■	-	-	-	-	-
MSK061C-...-NN-...1-....	■	■	-	-	-	-	-
MSK070C-...-NN-...0-....	-	-	■	-	-	-	-
MSK070C-...-NN-...1-....	-	-	■	-	-	-	-
MSK070D-...-NN-...0-....	-	-	■	□	-	-	-
MSK070D-...-NN-...1-....	-	-	■	□	-	-	-
MSK070E-...-NN-...0-....	-	-	■	■	-	-	-
MSK070E-...-NN-...1-....	-	-	■	■	-	-	-
MSK071C-...-NN-...0-....	-	-	■	■	-	-	-
MSK071C-...-NN-...1-....	-	-	■	■	-	-	-
MSK071C-...-NN-...2-....	-	-	■	■	-	-	-
MSK071D-...-NN-...0-....	-	-	■	■	-	-	-
MSK071D-...-NN-...1-....	-	-	■	■	-	-	-
MSK071D-...-NN-...2-....	-	-	■	■	-	-	-
MSK071E-...-NN-...0-....	-	-	■	■	-	-	-
MSK071E-...-NN-...1-....	-	-	■	■	-	-	-
MSK071E-...-NN-...2-....	-	-	■	■	-	-	-
MSK075C-...-NN-...0-....	-	-	■	■	-	-	-
MSK075C-...-NN-...1-....	-	-	■	■	-	-	-
MSK075C-...-NN-...2-....	-	-	■	■	-	-	-
MSK075D-...-NN-...0-....	-	-	■	■	-	-	-
MSK075D-...-NN-...1-....	-	-	■	■	-	-	-
MSK075E-...-NN-...0-....	-	-	■	■	-	-	-
MSK075E-...-NN-...1-....	-	-	■	■	-	-	-
MSK075E-...-NN-...2-....	-	-	■	■	-	-	-
MSK075E-...-NN-...3-....	-	-	■	■	-	-	-
MSK076C-...-NN-...0-....	-	-	■	□	-	-	-
MSK076C-...-NN-...1-....	-	-	■	□	-	-	-
MSK100A-...-NN-...0-....	-	-	-	-	■	-	-
MSK100A-...-NN-...1-....	-	-	-	-	■	-	-
MSK100B-...-NN-...0-....	-	-	-	-	■	■	-

Motor	LEM- AB-116T-...- NNNN	LEM- RB-116T-...- NNNN	LEM- AB-140T-...- NNNN	LEM- RB-140T-...- NNNN	LEM- AB-192T-...- NNNN	LEM- RB-192T-...- NNNN LEM- RB-192T-...- NNNA	LEM- AB-260N-...- NNNN
MSK100B-...-NN-...1-...	-	-	-	-	■	■	-
MSK100B-...-NN-...2-...	-	-	-	-	■	■	-
MSK100C-...-NN-...0-...	-	-	-	-	■	■	-
MSK100C-...-NN-...1-...	-	-	-	-	■	■	-
MSK100C-...-NN-...2-...	-	-	-	-	■	■	-
MSK100D-...-NN-...0-...	-	-	-	-	■	■	-
MSK100D-...-NN-...1-...	-	-	-	-	■	■	-
MSK100D-...-NN-...2-...	-	-	-	-	■	■	-
MSK101C-...-NN-...0-...	-	-	-	-	■	□	-
MSK101C-...-NN-...2-...	-	-	-	-	■	□	-
MSK101D-...-NN-...0-...	-	-	-	-	■	■	-
MSK101D-...-NN-...1-...	-	-	-	-	■	■	-
MSK101D-...-NN-...2-...	-	-	-	-	■	■	-
MSK101D-...-NN-...3-...	-	-	-	-	■	■	-
MSK101E-...-NN-...0-...	-	-	-	-	■	■	-
MSK101E-...-NN-...1-...	-	-	-	-	■	■	-
MSK101E-...-NN-...2-...	-	-	-	-	■	■	-
MSK101E-...-NN-...3-...	-	-	-	-	■	■	-
MSK103A-...-NN-...0-...	-	-	-	-	-	-	-
MSK103A-...-NN-...1-...	-	-	-	-	-	-	-
MSK103B-...-NN-...0-...	-	-	-	-	-	-	-
MSK103B-...-NN-...1-...	-	-	-	-	-	-	-
MSK103D-...-NN-...0-...	-	-	-	-	-	-	-
MSK103D-...-NN-...2-...	-	-	-	-	-	-	-
MSK131B-...-NN-...0-...	-	-	-	-	-	-	■
MSK131B-...-NN-...1-...	-	-	-	-	-	-	■
MSK131D-...-NN-...0-...	-	-	-	-	-	-	■
MSK131D-...-NN-...1-...	-	-	-	-	-	-	■
MSK131D-...-NN-...2-...	-	-	-	-	-	-	■

- not available, assembly not possible
- available assembled ex works
- available as mounting kit.

Tab. 7-5: Selection table motor fan unit



For fan units supplied as "attachment kit □", the assembly sequence must be observed.

1. flange the motor to the machine without the fan unit
2. mount the fan unit

Accessories

7.2.5 Fan units electrical connection

Connection 1-phase

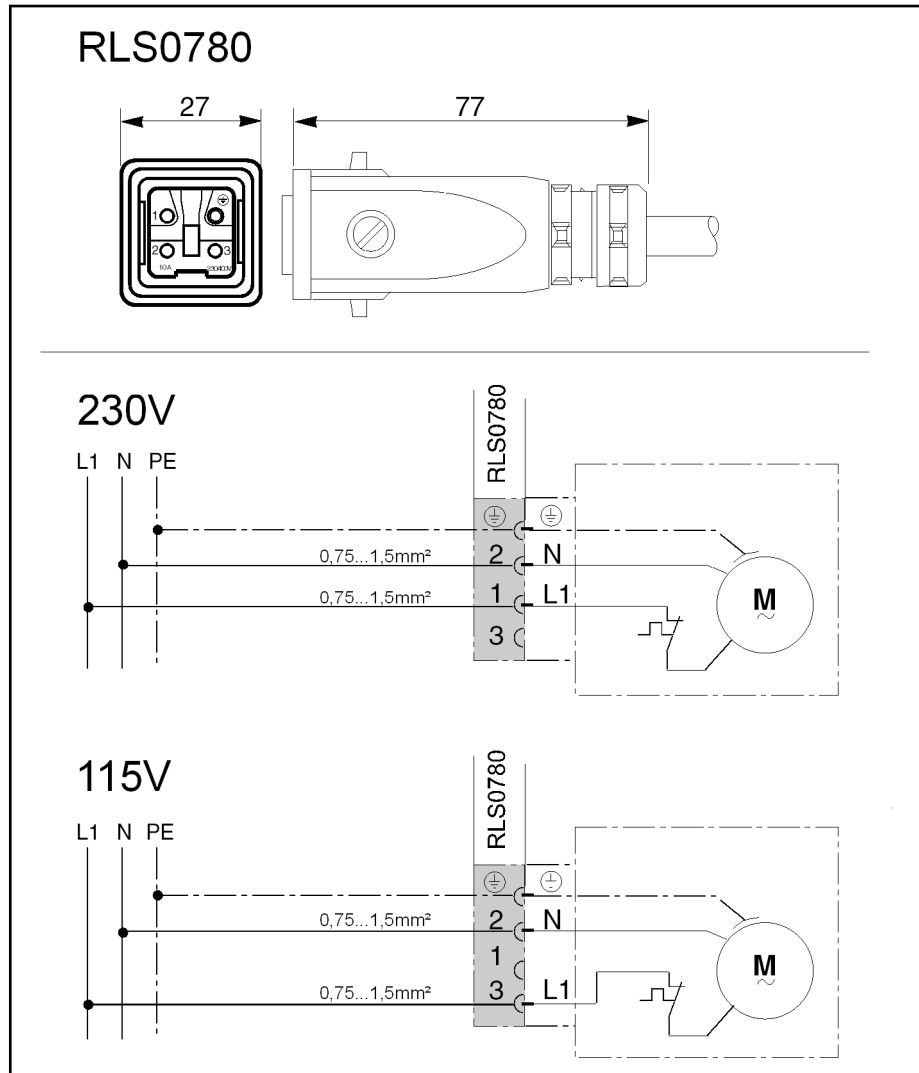

RLS0780 Clamping range cable gland 7 ... 10 mm

Fig. 7-3: Fan connection 1-phase with protection switch

LEM fan units in "T" version with integrated thermal protection do not require wiring with an external motor protection switch.



Protection against wrong connection!

- 230V: L1 to pin 1
- 115V: L1 to pin 3

Connection 3-phase

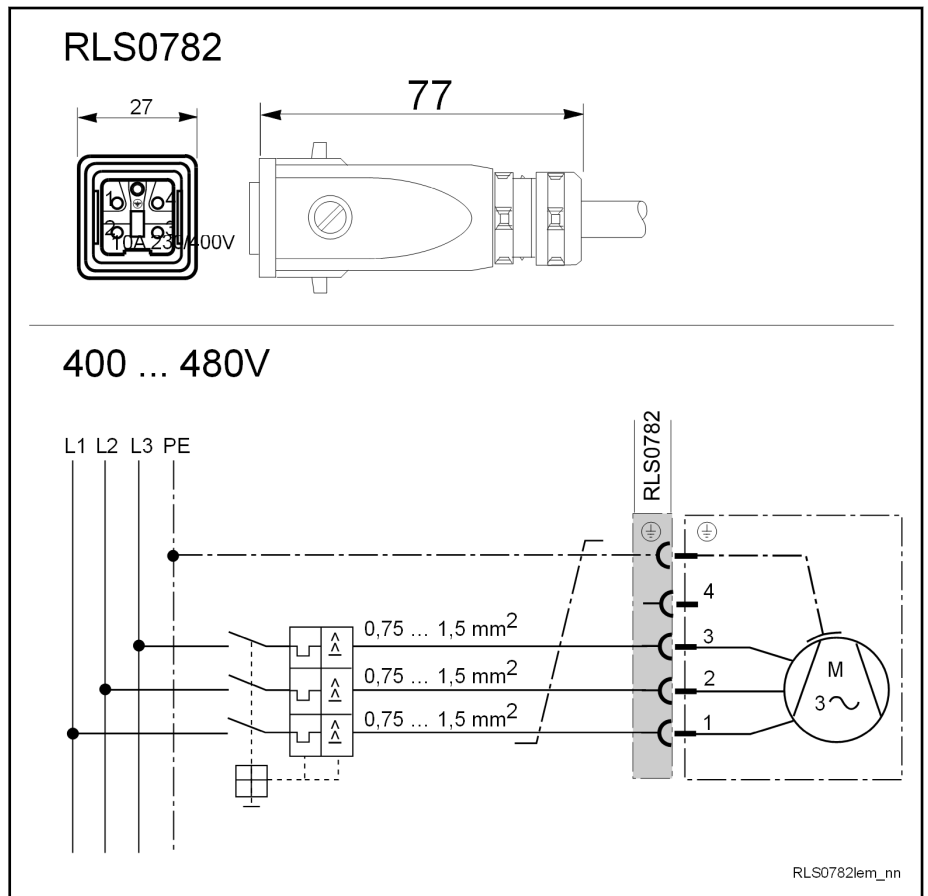

RLS0782 Clamping range cable gland 7 ... 10 mm

Fig. 7-4: 3-phase fan connection with protective switch

Protection by motor protection switch

The fan units are connected via adjustable motor protection devices.

The operating principle of the motor protection switches is based on the fact that the bimetal release through which the motor current flows is heated faster than the motor winding and disconnects it from the mains before critical temperature values are reached.

The motor protection switches are set to the rated current of the fan unit. When selecting the motor protection switches, make sure that the setting range matches the rated current of the fan unit.

Accessories

7.2.6 Fan units ordering

Motor with attached fan unit In order to obtain a motor with a fan unit attached, the type designation of the fan unit is indicated as the sub-order position of the motor.

Order position	Order designation
1	Synchronous motor
1.1	MSK100B-0300-NN-S1-BG1-NNNN
	Fan unit LEM-AB-192T-11-NNNA mounted to pos. 1

Motor with separate fan unit If the fan unit is identified as a separate order item, it is supplied separately from the motor (i.e. not attached).

Order position	Order designation
1	Synchronous motor
2	MSK100B-0300-NN-S1-BG1-NNNN
	Fan unit LEM-AB-192T-11-NNNA

7.2.7 Fan units assembly

For assembly instructions for the fan units, see Bosch Rexroth media directory.

7.3 Sealing air connection

7.3.1 Description

Sealing air accessory kits enable the introduction of a defined overpressure into the motor interior. This process reliably prevents the penetration of damaging liquids through endangered sealing points. Sealing air is used in all installation locations where moisture or coolants come into direct contact with the motors, especially in wet machining centers.



Damage due to liquid permanently present at the shaft sealing ring!

The use of sealing air does **not** prevent the penetration of liquids permanently present at the shaft sealing ring (e.g. in open transmissions). Due to capillary effects, transmission oil can penetrate the motors and cause damage despite the use of sealing air.

7.3.2 Technical data

Designation	Value
Operating pressure	0.1 ± 0.05 bar
Max. relative humidity	20...30 %
Air	dust-free, oil-free
Required compressed air hose	4 × 0.75 (not included in the scope of delivery)

Tab. 7-6: Technical data of the sealing air connection

7.3.3 Ordering data and assignment

Refer to the following table for the sealing air accessories for the required motor type.

Air-pressure connector kit	Order number	Motors
SUP-M01-MSK	R911306562	MSK030 MSK040 MSK050 MSK060 MSK061 MSK070 MSK071 MSK075 MSK076 MSK103
SUP-M02-MSK	R911315974	MSK100 MSK101 MSK131

Tab. 7-7: Selection of sealing air accessories

7.3.4 Assembly instructions

SUP-M01-MSK

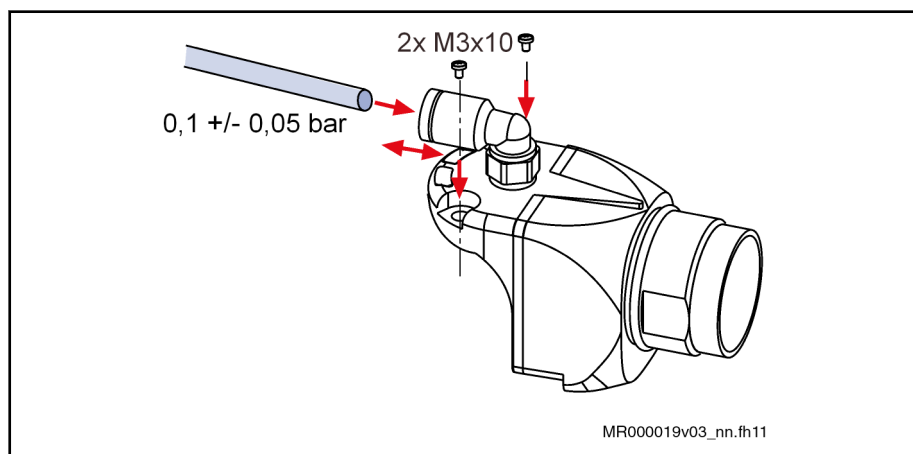

Fig. 7-5: RGS1000 with sealing air connection

⚠ DANGER

Fatal electric shock from live parts with more than 50V!

Only open the connector sockets of the motor when the system is de-energized!

1. Open main switch
2. Secure the main switch against being switched on again
3. Loosen the encoder connector cover screws and remove the cover.
4. Mount the sealing air connection



When fitting the cover, make sure that no cable core or seal is damaged.

Accessories

Screw the encoder connector cover with sealing air connection onto the motor. Tightening torque of the screws 1.3 Nm.

5. Connect the compressed air -quick coupling from the accessory kit to the regulated compressed air source.

The sealing air unit is now ready for operation.

SUP-M02-MSK

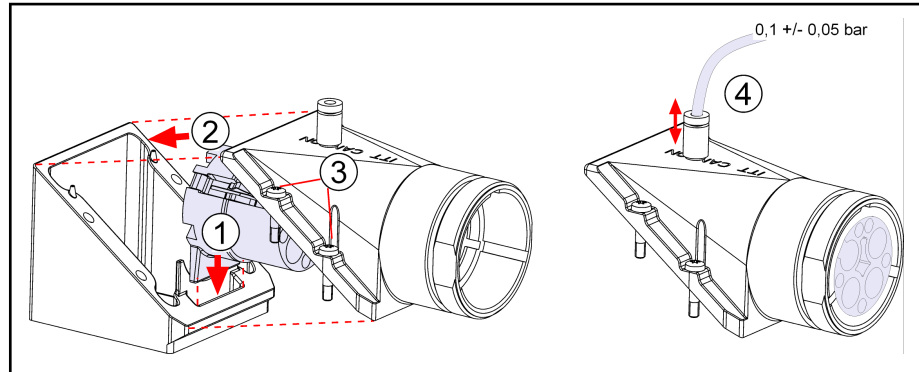

Fig. 7-6: RLS1300 with sealing air connection

⚠ DANGER

Fatal electric shock from live parts with more than 50V!

Only open the connector sockets of the motor when the system is de-energized!

1. Open main switch
2. Secure the main switch against being switched on again
3. Loosen the power connector cover screws and remove the cover.
4. Mount the sealing air connection



When fitting the cover, make sure that no cable core or seal is damaged.

Screw the power connector cover with sealing air connection onto the motor. Tightening torque of the screws 3.1 Nm.

5. Connect the compressed air -quick coupling from the accessory kit to the regulated compressed air source.

The sealing air unit is now ready for operation.

8 Connection technique

8.1 Overview of the electrical connection technique

Standard design MSK motors are connected via M23, M40, M58 circular connectors or terminal boxes.

The electrical connections are made according to the following table.

Motor	Power connection	Encoder connection
MSK030	RLS1100 (M23 flange socket)	RGS1000 (M23 flange socket)
MSK040	RLS1100 (M23 flange socket)	RGS1000 (M23 flange socket)
MSK043	RLS1100 (M23 flange socket)	RGS1000 (M23 flange socket)
MSK050	RLS1100 (M23 flange socket)	RGS1000 (M23 flange socket)
MSK060	RLS1100 (M23 flange socket)	RGS1000 (M23 flange socket)
MSK061	RLS1100 (M23 flange socket)	RGS1000 (M23 flange socket)
MSK070	RGS1200 (M40 flange socket)	RGS1000 (M23 flange socket)
MSK071	RGS1200 (M40 flange socket)	RGS1000 (M23 flange socket)
MSK075	RGS1200 (M40 flange socket)	RGS1000 (M23 flange socket)
MSK076	RLS1100 (M23 flange socket)	RGS1000 (M23 flange socket)
MSK100	RGS1300 (M58 flange socket)	RGS1003 (M23 flange socket)
MSK101	RGS1300 (M58 flange socket)	RGS1003 (M23 flange socket)
MSK103A	RLS1100 (M23 flange socket)	RGS1000 (M23 flange socket)
MSK103B MSK103D	RGS1200 (M40 flange socket)	RGS1000 (M23 flange socket)
MSK131	RGS1300 (M58 flange socket)	RGS1003 (M23 flange socket)
MSK133B	RLK1200 (terminal box)	RGS1003 (M23 flange socket)
MSK133C, -D, -E	RLK1300 (terminal box)	RGS1003 (M23 flange socket)

Tab. 8-1: MSK motors - electrical connections

Ready-made connection cables are available for all connection variants, ensuring simple, fast and fail-safe installation and commissioning.

Connection technique

Wiring diagram

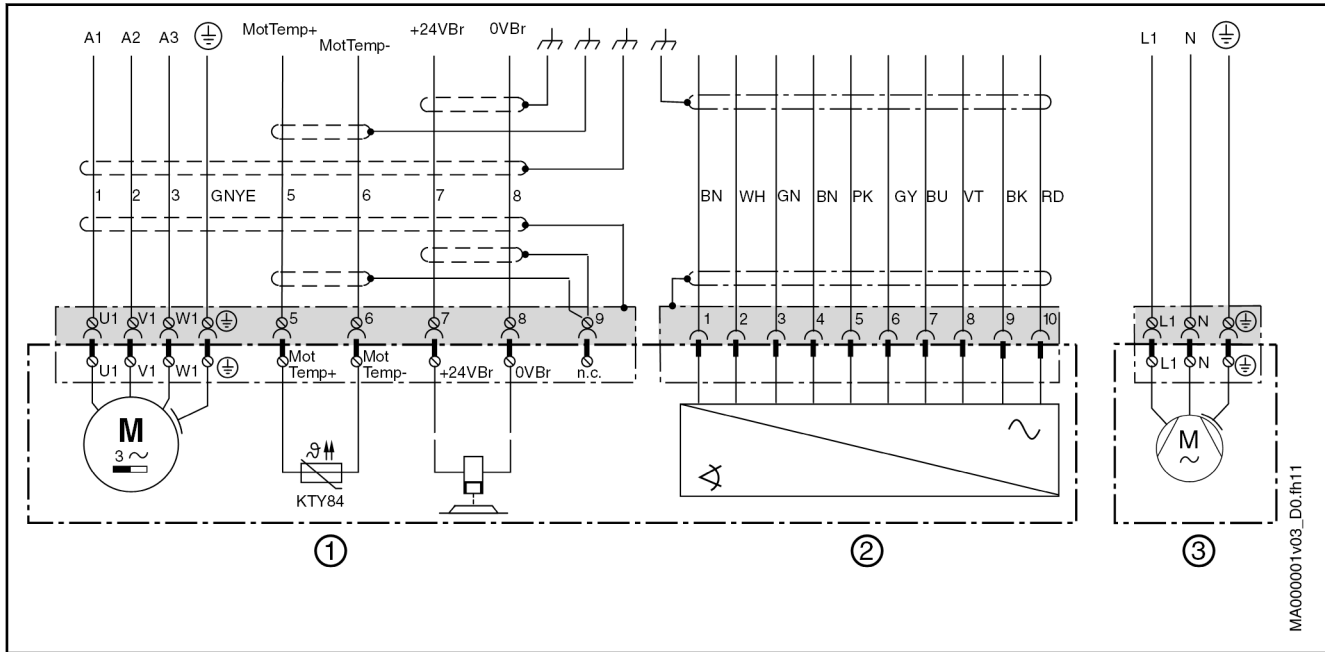

- ① Power connection with temperature sensor and holding brake (picture shows connector version)
- ② Encoder connection
- ③ Optional fan connection (not permitted for ATEX motors)

Fig. 8-1: Connection overview MSK motors

8.2 Plug-in power connector

M23 flange socket RLS1100

<p>View</p>	<p>Pole pattern</p> <ul style="list-style-type: none"> U1 A1 V1 A2 W1 A3 PE PE 5 MotTemp+ 6 MotTemp- 7 +24VBr 8 0VBr 9 n.c. 																
<p>Technical data</p> <table border="1"> <tr> <td>Connector size</td> <td>M23, rotatable</td> </tr> <tr> <td>Degree of protection</td> <td>IP67 (plugged)</td> </tr> <tr> <td>Temperature range</td> <td>-40 ... +125 °C</td> </tr> <tr> <td>Ambient temperature during operation</td> <td>40 °C</td> </tr> <tr> <td>Contact type</td> <td>Pins</td> </tr> <tr> <td>Rated voltage</td> <td>630 V / 125 V</td> </tr> <tr> <td>Rated current</td> <td>23 A</td> </tr> <tr> <td>Degree of contamination</td> <td>3</td> </tr> </table>		Connector size	M23, rotatable	Degree of protection	IP67 (plugged)	Temperature range	-40 ... +125 °C	Ambient temperature during operation	40 °C	Contact type	Pins	Rated voltage	630 V / 125 V	Rated current	23 A	Degree of contamination	3
Connector size	M23, rotatable																
Degree of protection	IP67 (plugged)																
Temperature range	-40 ... +125 °C																
Ambient temperature during operation	40 °C																
Contact type	Pins																
Rated voltage	630 V / 125 V																
Rated current	23 A																
Degree of contamination	3																

Connection technique

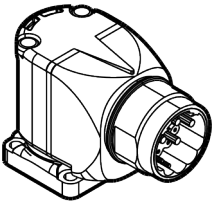
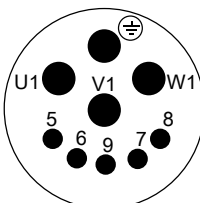
<p>View</p> 	<p>Pole pattern</p>  <ul style="list-style-type: none"> U1 A1 V1 A2 W1 A3 ⊕ PE 5 MotTemp+ 6 MotTemp- 7 +24VBr 8 0VBr 9 n.c.
Overvoltage category	III (DIN VDE 0110)
Flange socket, associated	RLS1101 for line cross-section 1.0 and 1.5 mm ² RLS1108 for line cross-section 2.5 mm ²

Tab. 8-2: Technical data RLS1100

M40 flange socket RLS1200

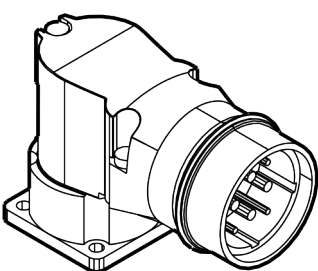
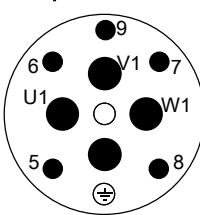
<p>View</p> 	<p>Pole pattern</p>  <ul style="list-style-type: none"> U1 A1 V1 A2 W1 A3 ⊕ PE 5 MotTemp+ 6 MotTemp- 7 +24VBr 8 0VBr 9 n.c.
Technical data	
Connector size	M40, rotatable
Degree of protection	IP67 (plugged)
Temperature range	-40 ... +125 °C
Ambient temperature during operation	40 °C
Contact type	Pins
Rated voltage	630 V / 125 V
Rated current	57 A
Degree of contamination	3
Overvoltage category	III (DIN VDE 0110)
Flange socket, associated	RLS1201

Tab. 8-3: Technical data RLS1200

Connection technique

M58 flange socket RLS1300

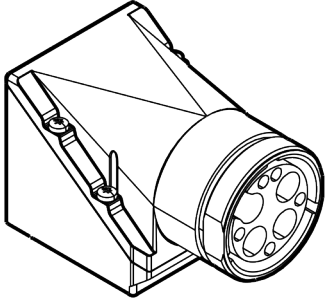
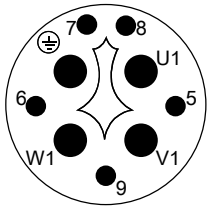
View		Pole pattern		
				U1 A1 V1 A2 W1 A3 PE 5 MotTemp+ 6 MotTemp- 7 +24VBr 8 0VBr 9 n.c.
Technical data				
Connector size	M58, fixed			
Degree of protection	IP67 (plugged)			
Temperature range	-40 ... +125 °C			
Ambient temperature during operation	40 °C			
Contact type	Pins			
Rated voltage	600 V			
Rated current	100 A (according to VDE, UL); 87 A (according to CSA)			
Degree of contamination	3			
Oversoltage category	III (DIN VDE 0110)			
Flange socket, associated	RLS1301			

Tab. 8-4: Technical data RLS1300

Flange socket 1~ RLS0779 for fan unit LEM

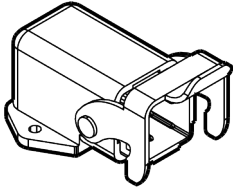
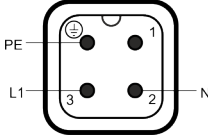
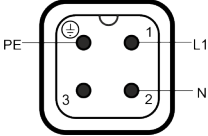
View		Pole pattern	
		RLS0779 (115 V) 	RLS0779 (230 V) 
Technical data			
Connector type	fixed		
Degree of protection	IP65 (plugged)		
Temperature range	-40 ... +120 °C		
Ambient temperature during operation	40 °C		
Contact type	Pins		
Rated voltage	L-PE 250 V / L-L 400 V (UL / CSA 600 V)		
Rated current	10 A		
Degree of contamination	3		
Flange socket, associated	RLS0780		

Tab. 8-5: Technical data RLS0779

Flange socket 3~ RLS0781 for fan unit LEM

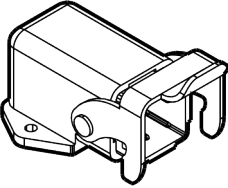
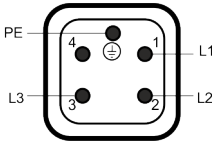
<p>View</p> 	<p>Pole pattern RLS0781 (400 V)</p> 
Technical data	
Connector type	fixed
Degree of protection	IP65 (plugged)
Temperature range	-40 ... +120 °C
Ambient temperature during operation	40 °C
Contact type	Pins
Rated voltage	400 V (UL / CSA 600 V)
Rated current	10 A
Degree of contamination	3
Flange socket, associated	RLS0782

Tab. 8-6: Technical data RLS0781

8.3 Encoder plug connector

M23 flange socket RGS1000

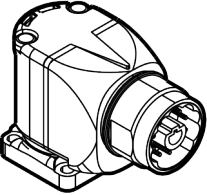
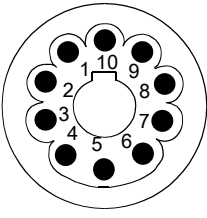
<p>View</p> 	<p>Pole pattern</p>  <ul style="list-style-type: none"> 1 VCC_Encoder 2 GND_Encoder 3 A+ 4 A- 5 B+ 6 B- 7 Enc_Data+ 8 Enc_Data- 9 Enc_CLK+ 10 Enc_CKL-
Technical data	
Connector size	M23, rotatable
Degree of protection	IP67 (plugged)
Temperature range	-40 ... +125 °C
Ambient temperature during operation	40 °C
Contact type	Pins
Rated voltage	125 V
Rated current	0.5 A
Degree of contamination	3
Overvoltage category	III (DIN VDE 0110)
Flange socket, associated	RGS1001

Tab. 8-7: Technical data RGS1000

Connection technique

M23 flange socket RGS1003

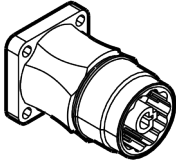
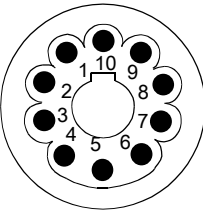
<p>View</p> 		<p>Pole pattern</p> 	
		1	VCC_Encoder
		2	GND_Encoder
		3	A+
		4	A-
		5	B+
		6	B-
		7	Enc_Data+
		8	Enc_Data-
		9	Enc_CLK+
		10	Enc_CLK-
<p>Technical data</p>			
Connector size	M23, fixed		
Degree of protection	IP67 (plugged)		
Temperature range	-40 ... +125 °C		
Ambient temperature during operation	40 °C		
Contact type	Pins		
Rated voltage	125 V		
Rated current	0.5 A		
Degree of contamination	3		
Oversvoltage category	III (DIN VDE 0110)		
Flange socket, associated	RGS1001		

Tab. 8-8: Technical data RGS1003

8.4 Plug connector, rotatable

The orientation of the flange socket is adjustable. To change the orientation, screw a coupling completely onto the flange socket. Then move the flange socket with the coupling to the desired position. The adjustment possibilities are shown in the following figure.

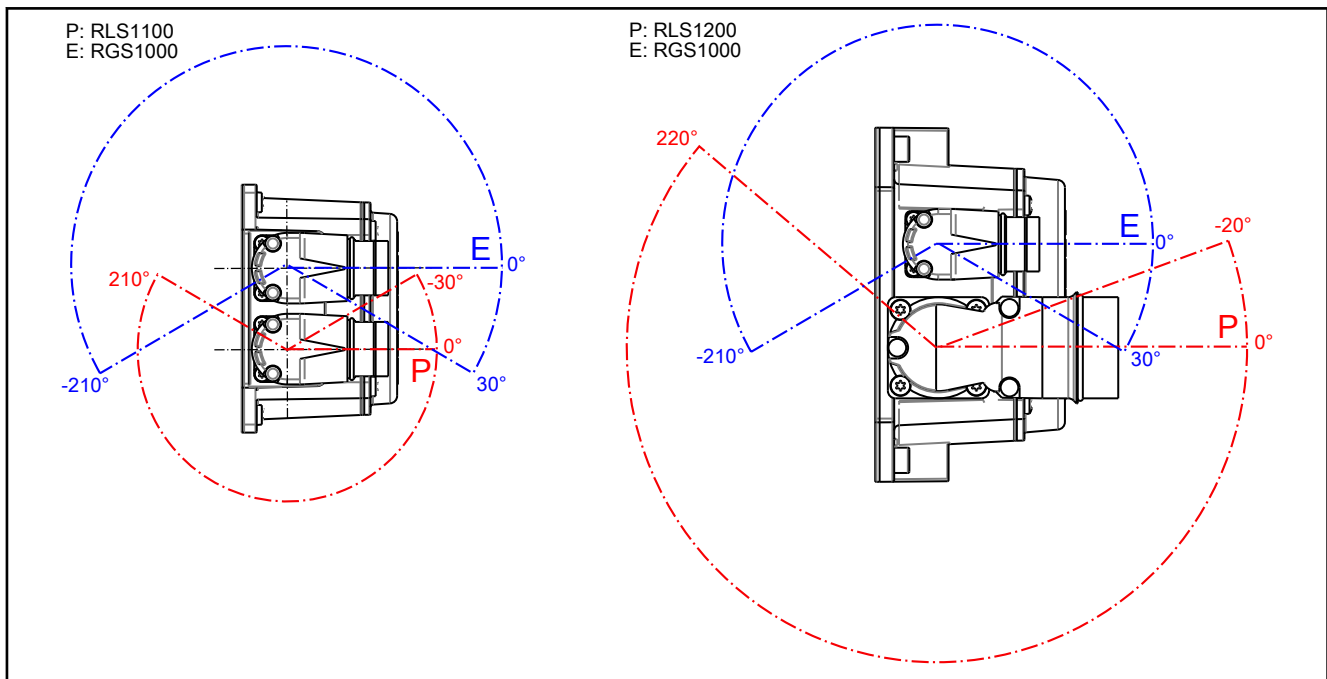

Fig. 8-2: Adjustment range of flange socket, rotatable

Connection technique

Flange socket	Twisting moment ¹⁾ maximum [Nm]
RGS1000	12
RLS1100	
RLS1200	18

1) Maximum torque to change the orientation of the flange sockets

Tab. 8-9: *Twisting moments of flange sockets*

Connection technique

8.5 RLK1200 Terminal box

The picture shows a terminal box, fully equipped, for double cabling.

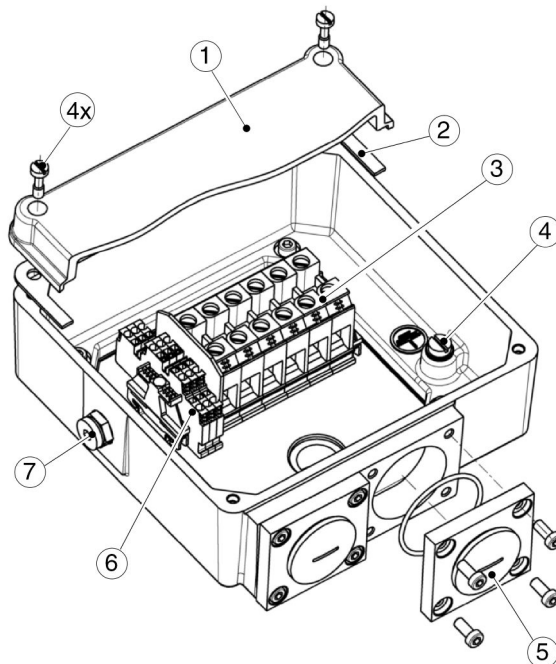

Connection components RLK1200 / RLK1201

Pos	Components within terminal box	Connection components for cables
(3)	Terminal block U-V-W	Wire end ferrules
(6)	Terminal strip (brake, temperature sensor)	Wire end ferrules
(4)	Protective conductor terminal	Ring terminal end M8
(5)	Adapter plate (metric thread) M25 × 1.5 / M32 × 1.5 alternatively: extension M32/40	EMC screw connection

Tab. 8-10: RLK1200/RLK1201, electrical connection components



Terminal box with metric thread. When ready-made, EMC screw connection required.

8.6 Terminal box RLK1300

The picture shows a terminal box, fully equipped, for double cabling.

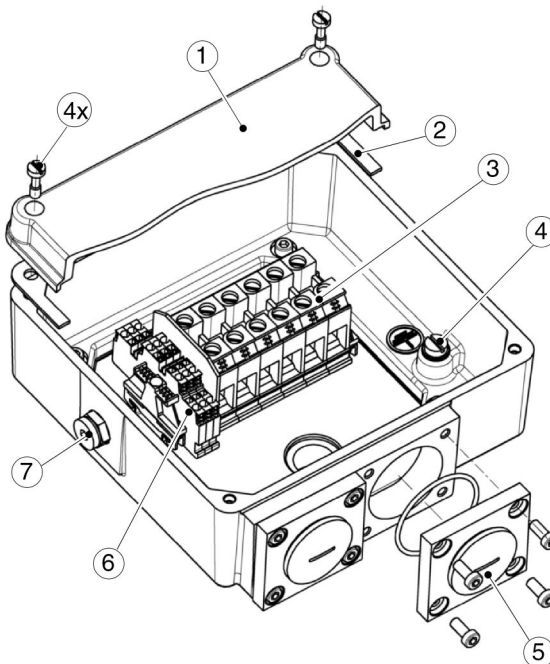

Connection components RKL1300 / RLK1301

Pos	Components within terminal box	Connection components for cables
(3)	Terminal block U-V-W	Wire end ferrules
(6)	Terminal strip (brake, temperature sensor)	Wire end ferrules
(4)	Protective conductor terminal	Ring terminal end M8
(5)	Adapter plate (metric thread) M25 × 1.5 / M32 × 1.5 / M40 × 1.5	EMC screw connection

Tab. 8-11: RLK1300/RLK1301, electrical connection components



Terminal box with metric thread. When ready-made, EMC screw connection required.

8.7 Connection cables

Rexroth supplies ready-made power and encoder cables. The documentation "Selecting the IndraDrive connection cable"; DOK-CONNEC-CABLE*INDRV-CAXx-EN-P is available for selecting the cables.

The achievable service life of the cables depends on the type of installation and environmental influences at the place of use. Observe the following recommendations for handling the cables to ensure long and trouble-free operation of the cables.

- Do not load the cables with tension or torsion
Fasten the cable ends after approx. 30 cm (e.g. cable clamp, shield connection of the controllers).
- Always pull the plug when disconnecting plug connections. Do not pull the cable.
- Do not bend the cable.

Connection technique

- Do not undercut the bending radius of the cable.
- Do not expose the cable to large temperature fluctuations and extreme weather conditions. Do not store outdoors. Store in a dry place.
- Always unwind the cable, do not unreel it "overhead".
- Do not use damaged cables (e.g. due to pressure, clamping or crushing). If the cable is damaged, shut down the system and replace the cable.

Observe the assembly and installation instructions for ready-made cables in the documentation "DOK-CONNEC-CABLE*INDRV-CAxx-EN-P".

8.8 Liquid cooling connection

Installation material such as hoses and mounting clamps are not included in the scope of delivery. Select the supply hose with the correct inner diameter.

Cooling connection

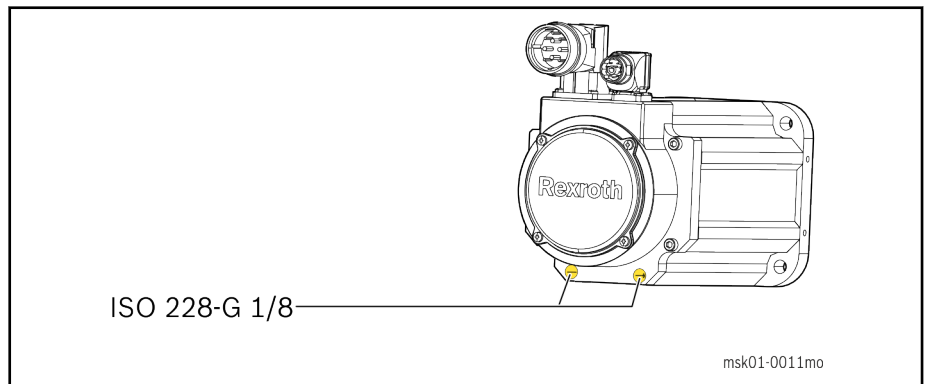

Fig. 8-3: Coolant connection MSK071, MSK075

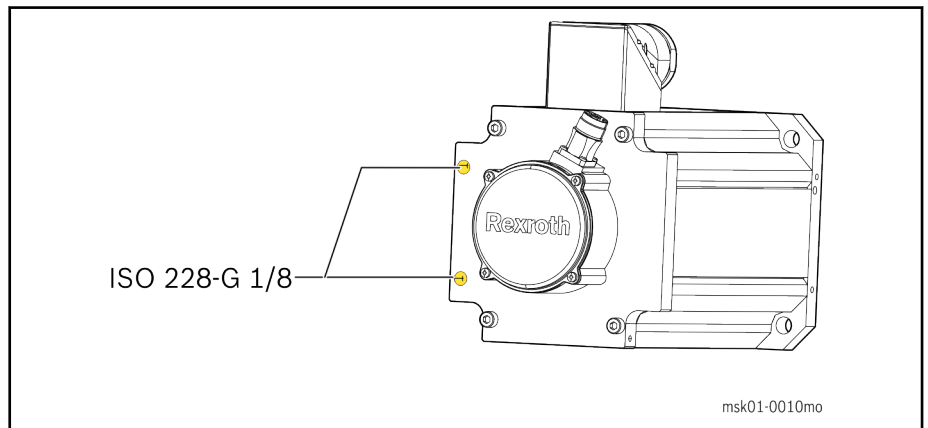

Fig. 8-4: Coolant connection MSK101

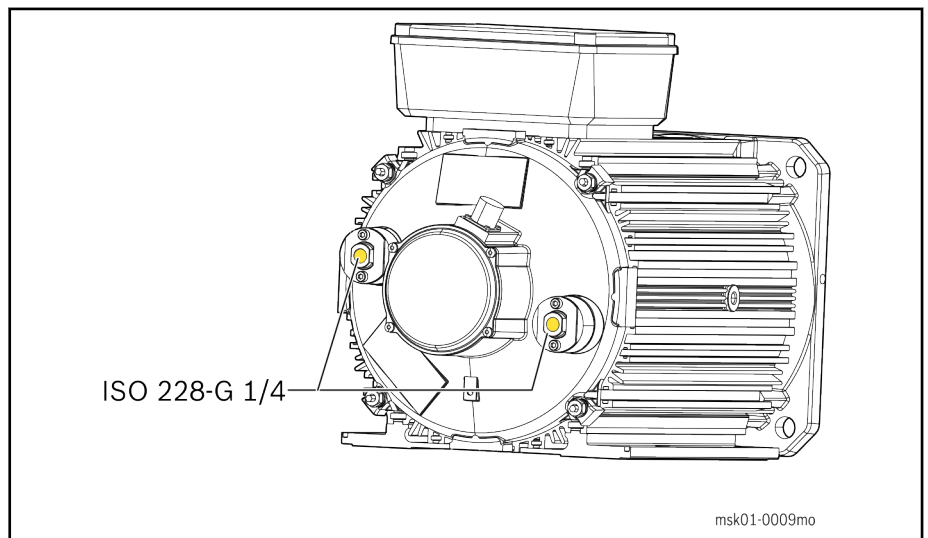

Fig. 8-5: Coolant connection MSK133



The assignment of inlet (IN) and outlet (OUT) can be made as desired and has no influence on the performance data of the motor.

Connection technique

The connecting threads on the motor are covered with factory-attached protective caps. These protective caps must only be removed immediately before screwing in the coolant lines or the quick coupling in order to prevent dirt from entering the cooling system.

The following table gives an overview of the height at which the motor-side connection threads may be loaded.

Motor	Connection	Screw-in depth [mm]	Tightening torque [Nm]
MSK071	Pipe thread ISO228-G 1/8	9	14 ... 15
MSK075			
MSK101	Pipe thread ISO228-G 1/8	10	14 ... 15
MSK133	Pipe thread ISO228-G 1/4	14	18 ... 20

Tab. 8-12: Cooling connection thread, permissible tightening torques and screw-in depths

NOTICE

The coolant port threads on the motor may be destroyed by incorrect tightening torques!

The allowed motor connection tightening torque may not be exceeded! If the tightening torque or screw-in depth is exceeded, the motor may be damaged irreversibly.

The coolant connections on the motor side are provided for coolant connection threads with axial sealing.

Bosch Rexroth recommends to use threaded connections which contain an O-ring for axial sealing of the screw connections.

For example, seals consisting of hemp, teflon tape or cone-shaped screw connections are not considered to be suitable, since this type of seal may stress the connection thread at the motor to an unreasonably high extent and/or damage it permanently.



The machine manufacturer is responsible for ensuring that the coolant connection is tight and for verifying and accepting the tightness after the motor has been installed.

Additional, regular inspections to ensure proper condition of the coolant connection should be logged in the maintenance schedule of the machine.

9 Operating conditions and application notes

9.1 Environmental conditions

9.1.1 Installation altitude and ambient temperature

The stated performance data of the motors are valid according to DIN EN 60034-1 for:

- Ambient temperature 0 ... 40 °C
- Installation altitude 0 ... 1000 m above sea level

If the specified limits are exceeded, the performance data of the motors must be reduced.

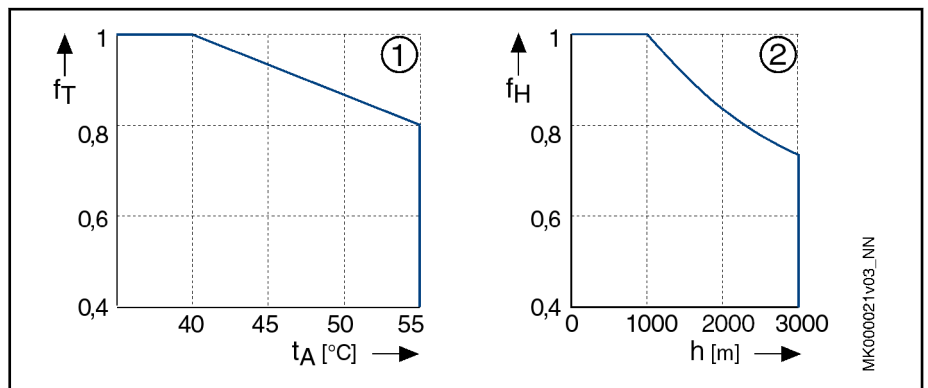

① Utilization depending on the ambient temperature

② Utilization depending on the installation altitude

f_T Temperature utilization factor

t_A Ambient temperature

f_H Height utilization factor

h Installation altitude in meters

Fig. 9-1: Derating of ambient temperature, installation altitude (in operation)

Calculation of performance data in case the limits specified are exceeded:

Ambient temperature > 40 °C

$$M_{0_red} = M_0 \times f_T$$

Installation altitude > 1,000 m

$$M_{0_red} = M_0 \times f_H$$

Ambient temperature > 40 °C and setup elevation > 1,000 m

$$M_{0_red} = M_0 \times f_T \times f_H$$

Operating conditions and application notes

9.1.2 Humidity / temperature

Climatic environmental conditions are defined according to different classes as specified in DIN EN 60721-3-3, Table 1. The conditions are based on observations made over long periods of time worldwide and take into account all influencing variables, such as the air temperature and humidity.

On the basis of this table, Rexroth recommends Class 3K4 for permanent use of the motors.

The following table provides extracts from this class.

Environmental factor	Unit	Class 3K4
Low air temperature	°C	0 ¹⁾
High air temperature	°C	+40
Low rel. air humidity	%	5
High rel. air humidity	%	95
Low absolute air humidity	g/m ³	1
High absolute air humidity	g/m ³	29
Temperature change rate	°C/min	0.5

1) Differs from DIN EN 60721-3-3, permissible

Tab. 9-1: *Classification of climatic environmental conditions according to DIN EN 60721-3-3, table 1*

9.1.3 Vibration

Vibrations are sine-wave oscillations in stationary use, which vary in their effect on the resistance of the motors depending on their intensity.

The specified limit values are valid for frequencies of 10-2,000 Hz during stimulation on the motor flange. Limitations can be necessary for occurring resonances depending from the application and installation situation.

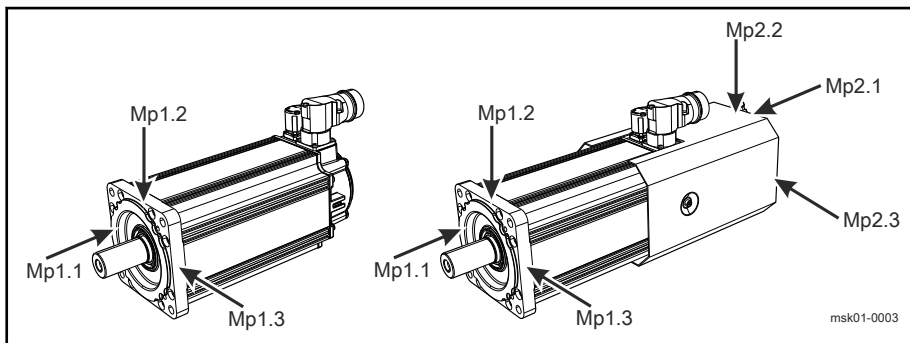

- Mp1.1** Measuring point motor flange axial
- Mp1.2, -1.3** Measuring point motor flange radial
- Mp2.1** Measuring point fan axial
- Mp2.2, -2.3** Measuring point fan radial

Fig. 9-2: Measuring points vibration load

The following limit values acc. to EN 60721-3-3 and EN 60068-2-6 are valid for MSK motors:

Direction	Measuring points	Maximum permissible vibration load (10-2,000 Hz)		
		MSK with encoder S2, S3, M1, M3	MSK with encoder S2, M2	MSK with LEM
Axial	Mp1.1	10 m/s ²	10 m/s ²	10 m/s ²
Radial	Mp1.2 Mp1.3	30 m/s ²	10 m/s ²	10 m/s ²

Tab. 9-2: Permissible vibration load for MSK motors

Additionally check the vibration load on the fan housing (Mp2.x) when fan mounting.

Direction	Measuring points	Maximum permissible vibration load (10-2,000 Hz)
		MSK with LEM
Axial	Mp2.1	10 m/s ²
Radial	Mp2.2 Mp2.3	30 m/s ²

Tab. 9-3: Permissible vibration load for MSK motors with fan unit

Operating conditions and application notes

9.1.4 Shock

MSK motors fulfill the demands on transport conditions of class 2M1 (state of shock during transport) acc. to EN 60721-3-2 compare with [chapter 10.1 "Transport Instructions" on page 237](#).

Function-impairing effects are avoided as long as the limits specified are kept.

Frame size	Maximum allowed shock load (11 ms)	
	Axial	Radial
MSK030 MSK040 MSK043 MSK050	100 m/s ²	1,000 m/s ²
MSK060 MSK061		500 m/s ²
MSK070 MSK071 MSK075 MSK076		300 m/s ²
MSK100 MSK101 MSK103 MSK131 MSK133		200 m/s ²

Tab. 9-4: Permitted shock load for MSK motors

The specified limit values are not valid for half-sinus-shaped single shock load acc. to EN 60068-2-27. This details are **not valid for motor operation**.

Applications with continuous shock load make a case-by-case review necessary.

9.2 Degree of protection

The protection type according to EN 60034-5 is determined by the abbreviation IP (International Protection) and two code numbers for the degree of protection. The first code number describes the degree of protection against contact with and ingress of foreign bodies, the second code number describes the degree of protection against ingress of water.

first code number	Degree of protection
6	Protection against penetration of dust (dust-proof); complete contact protection
4	Protection against ingress of solid foreign bodies with a diameter of more than 1 mm
2	Protection against ingress of solid foreign bodies with a diameter of more than 12.5 mm
second code number	Degree of protection
7	Protection against harmful effects when temporarily immersed in water.
5	Protection against a jet of water from a nozzle which is directed against the housing from all directions (jet water)
4	Protection against water splashing against the housing from all directions (splash water)

Tab. 9-5: IP protection types

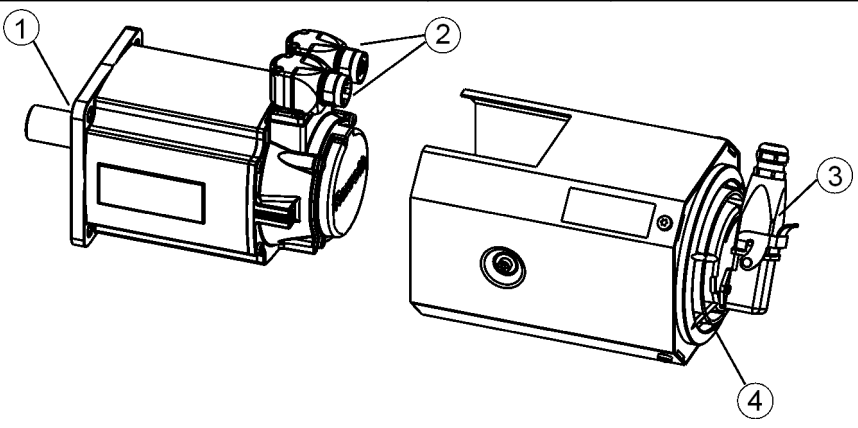
Motor area	Degree of protection	Note
		
Motor housing, output shaft, motor connector when properly assembled in mated condition	IP 65	Standard version
Motor housing, output shaft, motor connector when properly assembled in mated condition and use of sealing air	approx. IP67	Only with sealing air accessories!
Blower motor and connector in mated condition	IP 65	Blower unit accessories
Fan grille	IP 24	Blower unit accessories

- ① Output shaft with shaft sealing ring
- ② Connector for performance and encoder connection (optionally retrofittable for sealing air connection)
- ③ Blower motor with connector
- ④ Fan grille

Tab. 9-6: IP protection type ranges for MSK motors

The tests for the second code number are carried out with fresh water. If cleaning processes with high pressure and/or solvents, cooling lubricants or creep oils are used, a higher degree of protection may be required.

Operating conditions and application notes

9.3 Design and installation positions

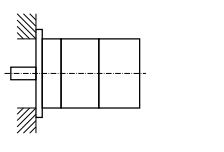
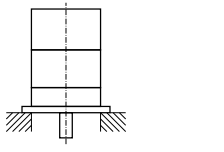
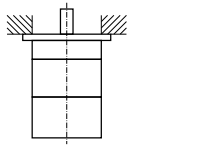
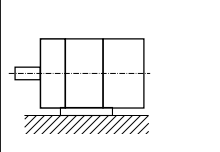
Motor design B05			
			
IM B5	IM V1	IM V3	IM B35
Flange attachment on the drive side of the flange	Flange attachment on the drive side of the flange, drive side facing down	Flange attachment on the drive side of the flange, drive side facing up	Flange attachment on the drive side of the flange or foot attachment

Tab. 9-7: Permissible conditions of installation according to EN 60034-7:1993

NOTICE Motor damage due to penetration of liquids!

If motors are attached according to IM V3, fluid present at the output shaft over a prolonged time may penetrate and cause damage to the motors. Ensure that fluid cannot be present at the output shaft.

Foot assembly

In contrast to flange assembly, radial forces may only be effective in a direction perpendicular to the mounting surface ($\pm 15^\circ$) if foot assembly is selected. The transmission of forces in other effective directions is not allowed.

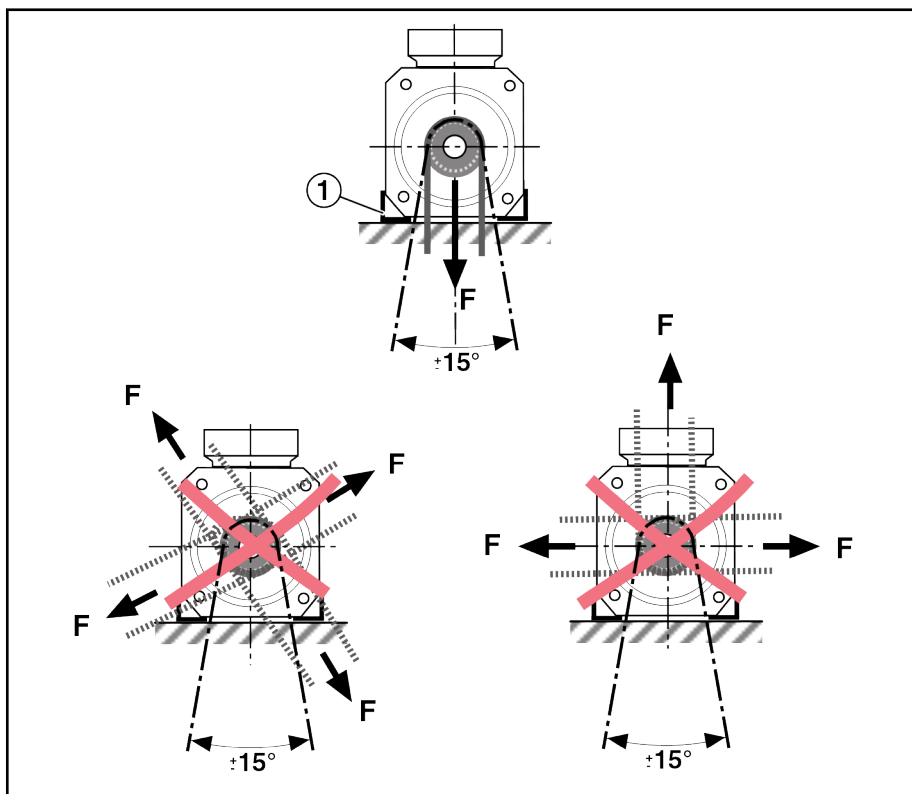

① Mounting feet
Fig. 9-3: Foot assembly



Please note the following in case of foot assembly ...

- Forces which are transmitted by a gear and have an effect on the motor feet are not allowed.
Forces taking effect via the gear shaft must be supported against the gear.
 - Incorrect installation situations give rise to forces which may cause short-term damage to the motors.
 - See also the instructions on foot assembly in [chapter 12.3 "Mechanical attachment"](#) on page 249. If necessary, consider "flange assembly" as an alternative.
-

Operating conditions and application notes

9.4 Compatibility with foreign materials

All Rexroth controls and drives are developed and tested according to the state of the art.

However, since it is impossible to follow the continuing further development of every material with which our controls and drives could come into contact (e.g. lubricants on tool machines), reactions with the materials that we use cannot be ruled out in every case.

For this reason, you must execute a compatibility test between new lubricants, cleansers, etc. and our housings and device materials before using these products.

9.5 Motor paint

As standard, the motors are **black (RAL9005)**.

An additional varnish with a coat thickness of max. 40 µm is permitted. Before painting the housing, check the adhesiveness and resistance of the new paint.



Protect all safety notes, type plates and open connectors with a painting protection when painting additionally. The functionality of the motor may not be reduced by an additional varnish.

Operating conditions and application notes

9.6 Output shaft

9.6.1 Plain shaft

The recommended standard version for MSK motors offers a force-fit, backlash-free shaft-hub connection with very quiet running. Use clamping sets, clamping sleeves or tensioning elements to couple the machine elements to be driven.

9.6.2 Output shaft with keyway

The optional key according to DIN 6885, Sheet 1, Edition 08-1968, allows form-locking transmission of torques with constant direction and low requirements for the shaft-hub connection.

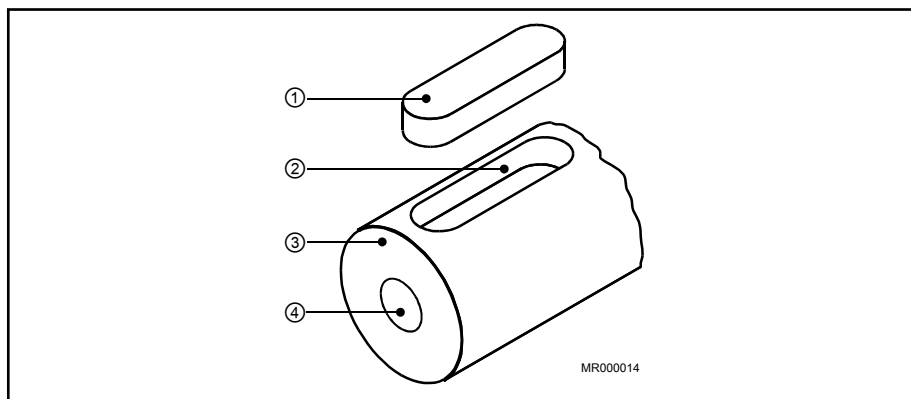

- ① Key
- ② Keyway
- ① Motor shaft
- ① Centering hole

Fig. 9-4: Output shaft with keyway

In addition, the machine elements to be driven must be secured axially via the frontal centering hole.

NOTICE

Damage to property due to reversing mode!

Shaft damage! In case of intense reversing operation, the seat of the fitting spring may deflect. Increasing deformations can lead to a break of shaft.

Preferably, use plain output shafts.

Balancing with full key

MSK motors are balanced with **full** key. The machine element to be driven must therefore be balanced without key.

9.6.3 Output shaft with shaft sealing ring

MSK motors are designed with radial shaft sealing rings according to DIN 3760 - version A.

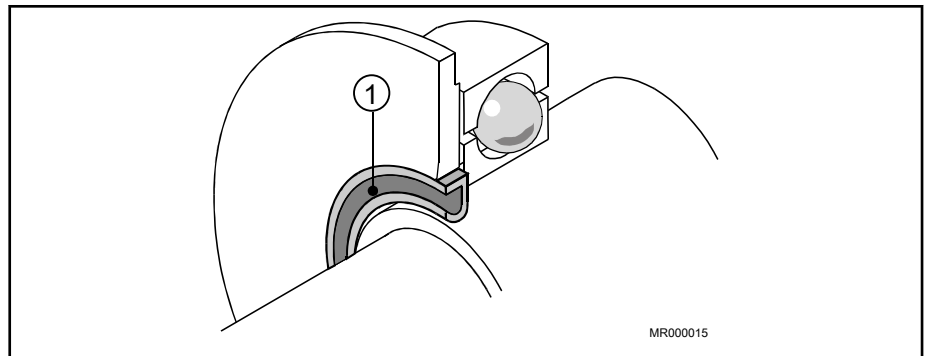

① Radial shaft sealing ring

Fig. 9-5: Radial shaft sealing ring

Wear Radial shaft sealing rings are abrasive seals. Wear and tear can only be reduced with sufficient lubrication and cleanliness of the sealing point. The lubricant simultaneously acts as a coolant and supports the dissipation of frictional heat from the sealing point.

Avoid dry running and soiling of the sealing point.



Under normal ambient conditions, shaft seals are greased for life. However, unfavorable environmental conditions (e.g. grinding dust, metal chips) may require maintenance intervals.

Stability The materials used for radial shaft sealing rings are highly resistant against oils and chemicals. However, the machine manufacturer is responsible for the suitability test for the respective operating conditions.

Vertical mounting positions IM V3 Motors with shaft sealing ring have protection class IP65 on the flange side. The tightness is therefore only guaranteed for splash liquids. Liquid levels on the A side require a higher protection type. If the motor is installed vertically (shaft upwards), also observe the instructions in [chapter 9.3 "Design and installation positions"](#) on page 208.



Rexroth recommends avoiding direct contact of the output shaft and radial shaft seal with the machining medium (cooling lubricant, material abrasion) due to the machine or system design.

Operating conditions and application notes

9.7 Bearing and shaft load

9.7.1 Radial load, axial load

During operation, radial and axial forces act on the motor shaft and the motor bearings. The design of the machine, the selected motor type and the shaft-side mounting of drive elements must be coordinated to ensure that the specified load limits are not exceeded.

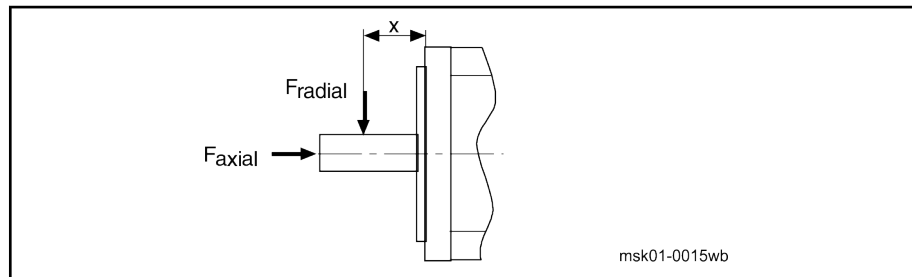

x Point of application of force

Fig. 9-6: Example diagram of shaft load

Maximum allowed radial force

The maximum permissible radial force F_{radial_max} depends on the following factors

- Shaft breaking load
- Force action point x
- Shaft plain or with keyway

Permissible radial force

The permissible radial load F_{radial} depends on the following factors

- Arithmetically averaged speed ($n_{average}$)
- Force action point x
- Bearing service life

Permissible axial force

The maximum permissible axial force F_{axial} for the individual motor sizes is shown in the following table.

Motor	F_{axial} [N]	Motor	F_{axial} [N]
MSK030	0	MSK075	60
MSK04x	30	MSK076	60
MSK050	40	MSK100	80
MSK060	40	MSK101	80
MSK061	40	MSK103	80
MSK070	60	MSK131	50
MSK071	60	MSK133	50

Tab. 9-8: Maximum permissible axial force F_{axial}

Axial forces are permissible without restriction up to the specified values. Larger axial forces may be possible after detailed examination by your Rexroth sales partner. Specify the following information for the valuation:

- Axial and radial force with force application point
- Installation position (horizontal, vertical with the shaft end pointing to the top or bottom)
- Average speed

Average speed

Run-up and braking times can be omitted from the calculation if the time during which the drive is operated at constant speed is considerably longer than

Operating conditions and application notes

the acceleration and braking times. In the exact calculation of the average speed according to the following pattern, acceleration and braking times are taken into account.

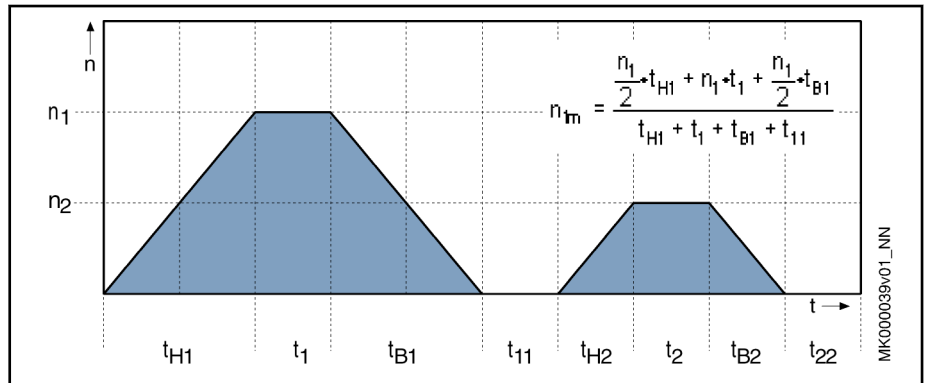

- $n_{1m}; n_{2m}$ Average speed section x
- $n_1; n_2$ Processing speed
- $t_{H1}; t_{H2}$ Run-up time
- $t_1; t_2$ Processing time
- $t_{B1}; t_{B2}$ Braking time
- $t_{11}; t_{22}$ Downtime

Fig. 9-7: Average speed

A complete processing cycle can consist of several sections with different speeds. In this case, the average of all sections shall be calculated.

Operating conditions and application notes

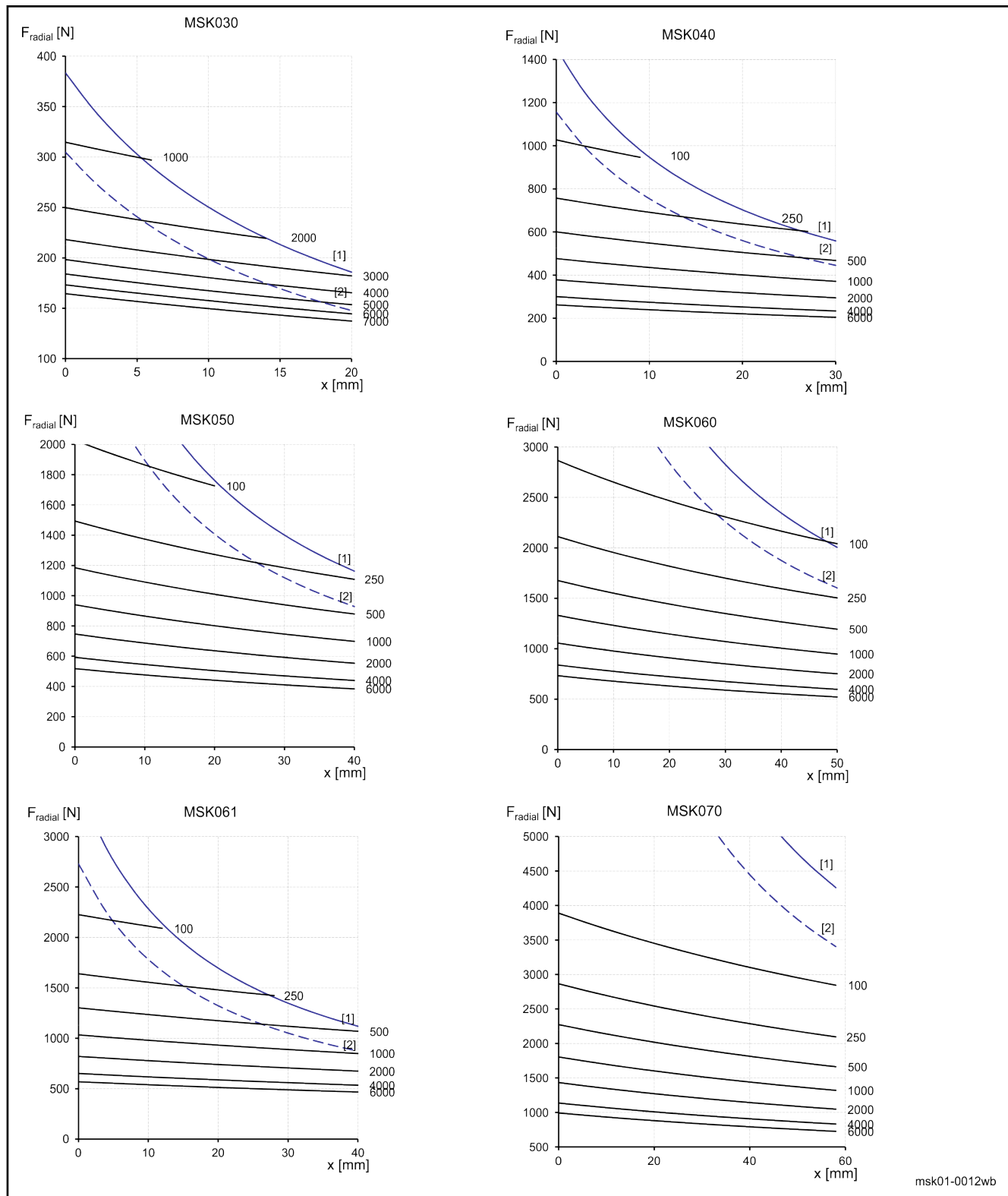

msk01-0012wb

[1] Shaft plain
 [2] Shaft with keyway
 n [min⁻¹] Average speed
 Fig. 9-8: Radial force $F_{radial}(1)$

Operating conditions and application notes

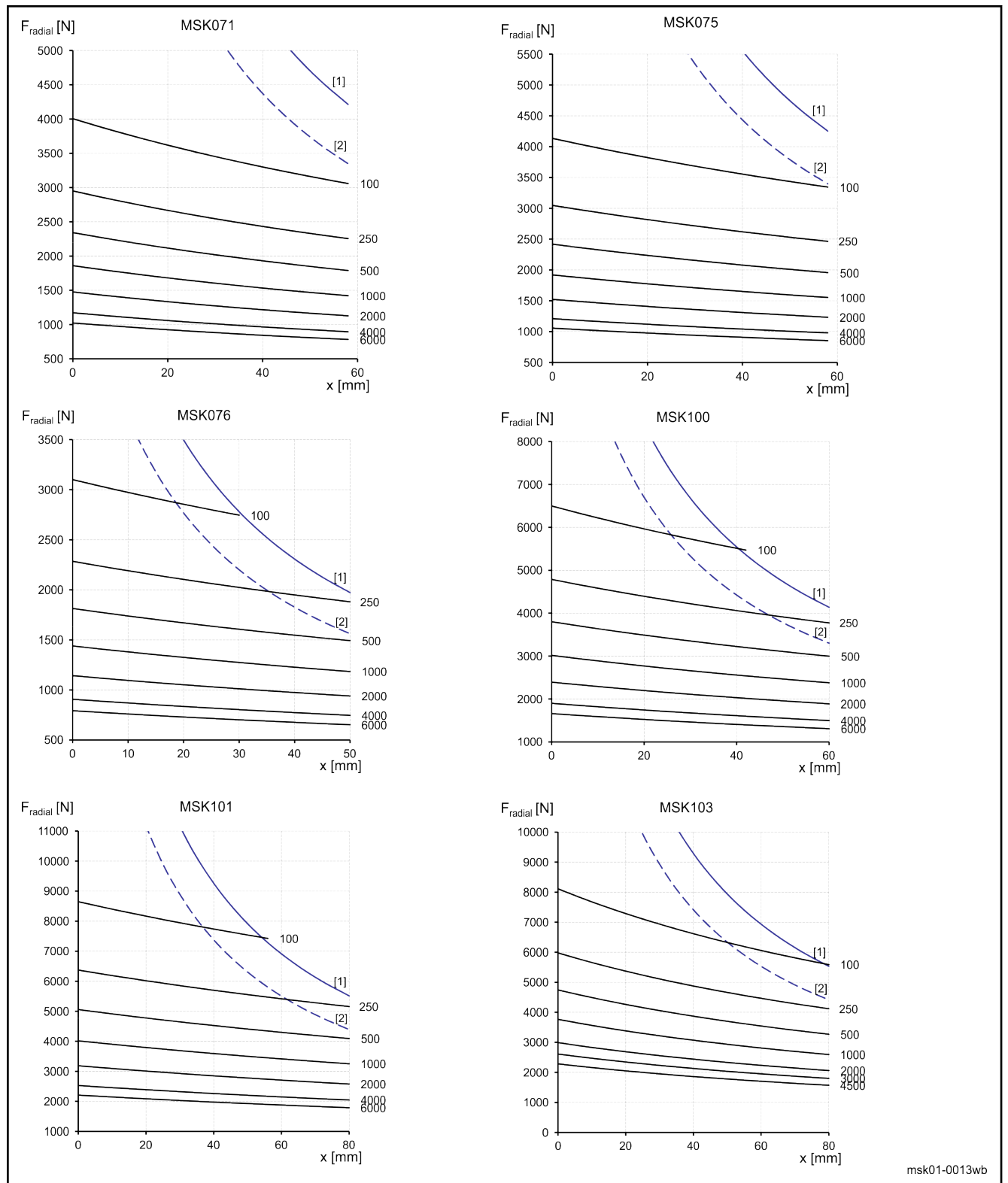

msk01-0013wb

[1] Shaft plain
 [2] Shaft with keyway
 n [min⁻¹] Average speed
 Fig. 9-9: Radial force $F_{\text{radial}}(2)$

Operating conditions and application notes

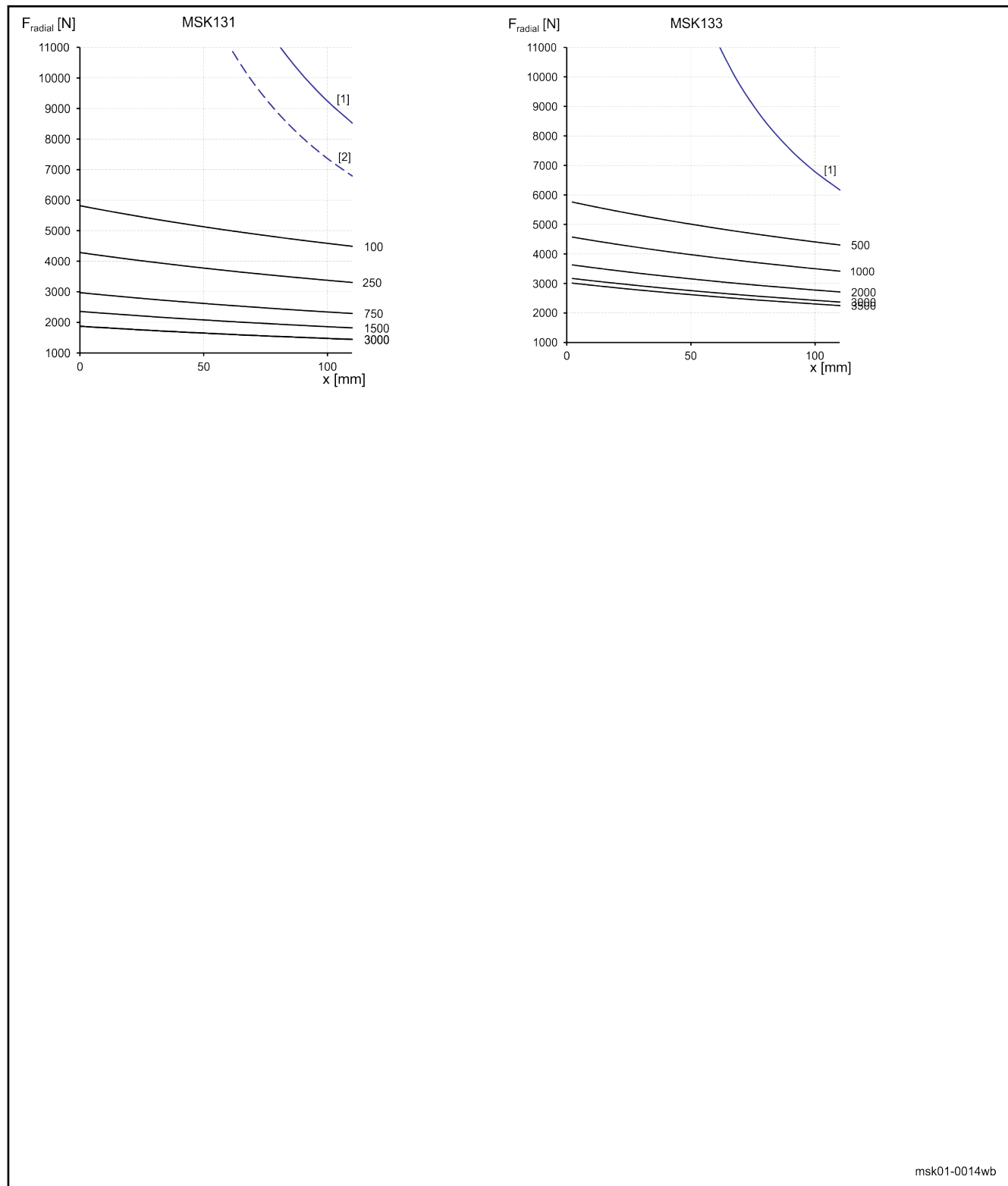

msk01-0014wb

- [1] Shaft plain
 - [2] Shaft with keyway
 - n [min⁻¹] Average speed
- Fig. 9-10: Radial force F_{radial} (3)

9.8 Bearing lifetime

The bearing lifetime for MSK motors for operation within the specified limits for radial and axial load and for ambient conditions is:

$$L_{10h} = 30000 \text{ h (calculation acc. to ISO 281, edition 12/1990)}$$

Different loads may have the following effects:

- Premature failure of the bearing due to increased wear or mechanical damage.
- Reduction of the grease lifetime leads to premature failure of the bearing.

Bearing lifetime with increased radial force

Calculation of mechanical bearing lifetime at increased radial force:

$$L_{10h} = \left(\frac{F_{radial}}{F_{radial_ist}} \right)^3 \cdot 30000$$

L_{10h} Bearing service life (according to ISO 281, Version 12/1990)

F_{radial} Determined allowed radial force in N (newton)

F_{radial_act} Actually acting radial force in N (newton)

Fig. 9-11: Calculation of bearing lifetime L_{10h} at increased radial force:



The actually acting radial force F_{radial_act} may never be higher than the maximum allowed radial force F_{radial_max} .

Operating conditions and application notes

9.9 Attachment of drive elements

CAUTION

Motor damage by intrusion of liquid!

Pending liquids (e.g. cooling lubricants, gearbox oil, etc.) at the drive shaft are inadmissible.

When installing gearboxes please use gearboxes with closed (oil-proof) lubrication system only. Gearbox oil should not be in permanent contact with the shaft sealing ring of the motors.

For any type of attachment of drive elements to the output shaft, such as:

- Transmissions
- Couplings
- Pinions

the following instructions must absolutely be observed.

Notes [chapter 7.1 "Transmission" on page 179](#).

Attachment of transmissions on motors

Over-determined arrangement

In general, an over-determined arrangement must be avoided when mounting drive elements. The indispensable existing tolerances lead to additional forces on the bearing of the motor shaft and, if necessary, to a significantly reduced bearing life.



If an over-determined arrangement cannot be avoided, please contact Bosch Rexroth.

Couplings

The machine design and the attachment elements used must be carefully matched to the motor type so that the load limits of shaft and bearing are not exceeded.



When mounting extremely rigid couplings, an unacceptably high load on the shaft and bearing can occur due to a radial force which constantly changes the angular position.

Bevel pinion or helical drive pinions

Due to thermal effects, the flange end of the output shaft can shift by up to 0.6 mm in relation to the motor housing. When using helical drive pinions or bevel gear pinions mounted directly on the output shaft, this change in length leads to

- a shift in the position of the axis, if the driving pinions are not axially fixed on the machine side,
- a thermally dependent component of the axial force, if the driving pinions are axially fixed on the machine side. There is a risk that the maximum permissible axial force will be exceeded or that the backlash within the gearing will increase excessively.
- Damage to the B-side motor fixed bearing due to exceeding the maximum permissible axial force.



Preferably use self-supported drive elements which are connected to the motor shaft via axially compensating couplings!

9.10 Holding brakes

9.10.1 Holding brake electrically releasing

Holding brakes of MSK motors work according to the principle of "electrically releasing". The holding brakes are released when applying the switching voltage.

The power supply of the holding brake must be designed in such a way as to guarantee under the worst installation and operation conditions that sufficient voltage of $24\text{ V} \pm 10\%$ is available on the motor in order to bleed the holding brake.

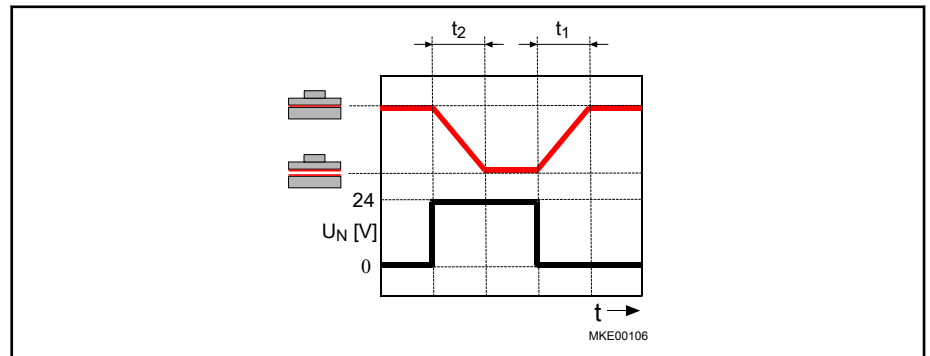

t_1 Connection time
 t_2 Disconnection time

Fig. 9-12: Switching condition holding brake over time

The holding brake is used to hold axes at standstill and with drive enable switched off. If the supply voltage fails or the drive enable is switched off, electrically releasing holding brakes close automatically.



Do not use the holding brake as a service brake for moving axes.

If the holding brake is repeatedly activated while the drive is rotating or the permissible braking energy is exceeded, premature wear may occur.

9.10.2 Holding brakes safety instructions

Observe the safety requirements when designing the system.

⚠ WARNING

Serious bodily injury due to dangerous movements caused by dropping or sinking axes!

Secure vertical axes against dropping or sinking after switching off by e.g.:

- Mechanical locking of the vertical axis
- External brake, arrestor, clamping device.
- Axis weight compensation



The holding brakes supplied as standard and controlled by the controller alone are **not** suitable for personal protection!

Personal protection must be achieved by means of overriding fail-safe measures, such as e.g. danger zones that are sealed off by protective fences or protective grids.

Operating conditions and application notes

In addition to the information and notes on the holding brake given here, additional standards and guidelines must be observed when designing the system.

In the area of European countries e.g.:

- EN 954; ISO 13849-1 and ISO 13849-2 Safety-related parts of control units
- Information Sheet No. 005 "Gravity loaded axes (vertical axes)" - published by: Technical Committee Mechanical Engineering, Manufacturing Systems, Steel Construction

For the US:

- See National Electrical Code (NEC), National Electrical Equipment Manufacturers Association (NEMA) and regional building codes.

The national regulations must be observed!

The permanent magnetic brake is no safety brake. This means, a torque reduction by non-influenceable disturbance factors can occur (see EN 954; ISO 13849-1; ISO 13849-2 or Information Sheet No. 005 "Gravity loaded axes (vertical axes)").

Particular attention must be paid to this:

- Corrosion on the friction surfaces as well as vapors, exhalations and deposits reduce the braking effect.
- Lubricants must not get onto the friction surface.
- Over-voltages and excessively high temperatures can permanently weaken the permanent magnets and thus render the holding brake unusable.

If the air gap between armature and pole increases due to wear, the function of the holding brake is no longer guaranteed.

Checking the holding brake during operation (recommendation)

Faults which occur during the operating period and which may change the design parameters or the operating conditions must be detected and eliminated within a reasonable period of time. In this case, we recommend checking the function and condition of the holding brake at regular intervals.

9.10.3 Design of holding brakes

Holding brakes on motors are generally not designed for service braking. The effective braking torques are physically different in static operation and dynamic operation.

Normal operation and EMERGENCY STOP	Malfunction
<p>In normal operation, using the holding brake for clamping an axis in standstill, the "static holding torque" (M_4) – static friction takes effect.</p> <p>At an EMERGENCY STOP for stopping an axis ($n < 10 \text{ min}^{-1}$), a "dynamic braking torque" (M_{dyn}) - sliding friction - takes effect.</p>	<p>In the event of a malfunction, using the holding brake to stop an axis in motion ($n \geq 10 \text{ min}^{-1}$), a "dynamic braking torque" (M_{dyn}) - sliding friction - takes effect.</p>
<p style="text-align: center;">$M_4 > M_{dyn}$</p> <p style="text-align: center;">Therefore, please note the following description of the dynamic design.</p>	

Tab. 9-9: Dynamic design

Dynamic design The load torque must be lower than the minimum dynamic torque M_{dyn} which the holding brake can provide. Otherwise the deceleration effect of the holding brake is not sufficient to stop the axis.

In order to decelerate a mass in a defined time or over a defined distance, the mass inertia of the whole system must be additionally taken into account.

Project planning recommendation In order to ensure plant safety, the holding torque required by the application must be reduced to 60% of the static holding torque (M4) of the holding brake.

9.10.4 Holding brake - commissioning and maintenance instructions

To ensure the function of the holding brake, the holding brake must be checked before commissioning the motors. The check and, if necessary, the loop-in can be carried out "mechanically by hand" or "automatically by software function".

Manual check and loop-in of the holding brakes Measure the holding torque (M4) of the holding brake, if necessary loop in the holding brake.

Measure the holding torque (M4) of the holding brake

1. Disconnect the motor from the power supply and secure it against being switched on again.
2. Measure the transferable holding torque (M4) of the holding brake with a torque wrench. Holding torque (M4): see technical data.

When the specified holding torque (M4) is reached, the motor is ready for installation.

If the specified holding torque (M4) is **not reached**, the holding torque can be restored by the subsequent loop-in process.

Looping in the holding brake

1. With the holding brake closed, turn the output shaft approx. 5 turns by hand, for example with a torque wrench.
2. Measure holding torque (M4).

When the specified holding torque (M4) is reached, the motor is ready for installation.

If the specified holding torque (M4) is not reached after several loops, the holding brake is not functional. Please contact the service of Rexroth.

Check and loop-in of the holding brakes via software function

Check holding torque (M4) by command Holding system check P-0-0541, C2100

1. The effectiveness of the holding brake and the open state is checked by the drive controller by starting the routine "P-0-0541, C2100 command Holding system check".

If the holding brake is OK, the drive is ready for operation after the routine has expired. If the braking torque is too low, the drive control unit issues a corresponding message.



The brake test can also be carried out cyclically as part of preventive maintenance.

Restore holding torque (M4) via software function

The following options are available:

Operating conditions and application notes

1. Execution of the loop-in routine "Restoring of the holding torque" (see "P-0-0544, C3900 Command Looping in the motor holding torque"). Multiple execution of this loop-in routine is possible.

Executing command C3900 does not check whether the holding brake was successfully looped in. It is recommended to re-execute command C2100 (Holding system check).

2. Loop-in routine by higher-level control. Here, control programs tailored to the machine and system concepts are required. If required, contact your sales partner at Rexroth and discuss the parameters of the loop-in routine for your application.

 For further information on software functions, see firmware function description.

9.11 Acceptances and approvals

9.11.1 CE



Certificate of conformity certifying the structure of and the compliance with the valid EN-standards and EC-guidelines are available for all MSK-motors. If required, the declarations of conformity can be requested from the responsible sales office.

The CE-mark is applied to the motor type label of the MSK-motors.

9.11.2 cURus



MSK motors are listed by the UL authority (Underwriters Laboratories Inc.®) under **file number E335445**. Approved engines are marked with the following symbol on the motor type label. Current information on UL approvals can be found at <http://www.ul.com/global/eng/pages/>.

9.11.3 EAC



In accordance with EAC certificate DCTC 30834-005, we confirm the conformity of our products with the prescribed technical requirements of the member states of the customs union EAC. The member states are Russia, Belarus and Kazakhstan.

9.11.4 RoHS



In accordance with our manufacturer's declaration DCTC 30806-001, we confirm that our products conform to the directive 2011/65/EG "RoHS II Restriction of the use of certain hazardous substances in electrical and electronic equipment".

9.11.5 China RoHS 2

www.boschrexroth.com.cn/zh/cn/home_2/china_rohs2

Operating conditions and application notes

9.12 Motor cooling

9.12.1 Natural convection

Rexroth motors in standard design are self-cooling. The heat dissipation is realized via natural radiation to the ambient air and by heat conduction to the machine structure. The nominal data are achieved at ambient temperatures of up to 40 °C. Sufficient heat radiation must be ensured by the installation situation. Unhindered vertical convection has to be ensured by a sufficient distance of 100 mm to adjacent components on the side surfaces.



Contamination of the motors reduces heat dissipation. Pay attention to cleanliness!

9.12.2 Fan units

Fan units are available for certain motor types. The performance data given in the technical data are marked with the index "S" for "surface". Descriptions of the technical data of the available fan units can be found at [chapter 7.2 "Fan units for MSK motors"](#) on page 180.

Cooling takes place via air streams which are guided over the surface of the motor by air baffles. The fan is designed to use clean air from its surroundings to cool the motor.

The use of the fan under the following conditions is expressly not suitable:

- Delivery of air which contains abrasive particles
- Delivery of air which has a strongly corroding effect, e.g., salt mist
- Delivery of air which contains a high dust load, e.g., extraction of saw dust
- Conveying of flammable gases/particles
- Use of the fan units as safety-related components or for the assumption of safety-relevant functions

In order for the required air volume to be converted by the fan unit, a minimum distance must be maintained between the fan grille and the machine for the air to be sucked in or blown out. The distance results from the motor structure.

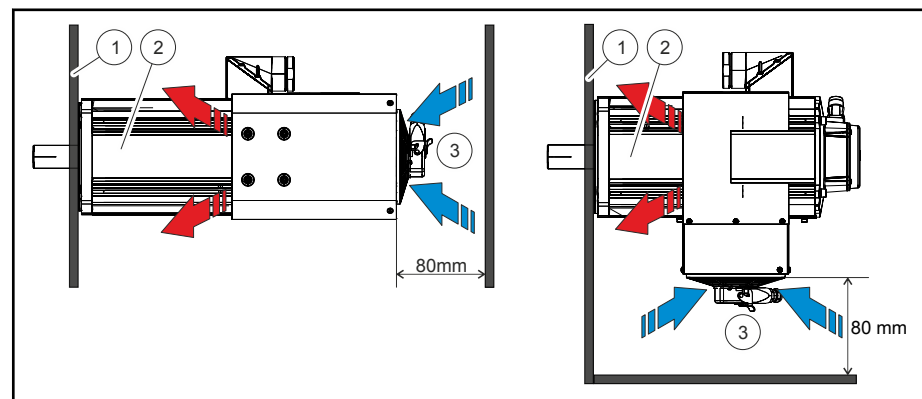

- ① Machine
② Air outlet space
③ Air suction area

Fig. 9-13: Fan units installation area, minimum distance

Consider the minimum distance of the air supply ③ when designing the machine.

Contamination can reduce the flow rate of the fans and lead to thermal overload of the motors. When the motors are operated in a dirty environment, the availability of the system is increased by cleaning the fans and motor cooling fins at regular intervals. When designing the machine, consider the accessibility of motor and fan for maintenance work. Special instructions for maintenance and troubleshooting of motor fans can be found in [chapter 13.4 "Maintenance"](#) on page 261.

9.12.3 Liquid cooling

General information

Rexroth motors in liquid-cooled version are suitable for increased loads, e.g. for continuous start-stop operation with high repetition frequencies. MSK motors for liquid cooling are marked with "FN" in the type code.

Coolant duct Coolant ducts can be designed as

- pipeline system or
- as hose

system.



Due to the deflection points occurring in piping systems (e.g. 90° bends), pressure losses occur in the coolant lines. Therefore we recommend hose line systems.

When selecting the coolant lines, the pressure drop within the system must be taken into account. For longer lengths, the inner diameter of the cables should therefore be at least 9 mm and taper only shortly before connection to the motor.

Operating pressure

The maximum coolant inlet pressure of **6 bar** shall be applicable to all MSK motors. For motors manufactured before 2010-01-01 **FD 10W01** the inlet pressure must be limited to 3 bar.

Please observe that additional screw connections or junctions in the cooling circuit can have an influence on the flow and supply pressure of the cooling medium. The pressure drop Δp_n of the liquid-cooled motors is specified in the technical data.

Pressure drop

The flow of the coolant in the drive component is exposed to cross-sectional and directional changes. Friction and deflection losses thus occur in the component. These losses appear in the form of a pressure drop Δp .

It refers to the indicated flow rate of the coolant water. If the flow rate is converted to a different temperature increase, the pressure drop must be taken from the following characteristic curve.

Operating conditions and application notes

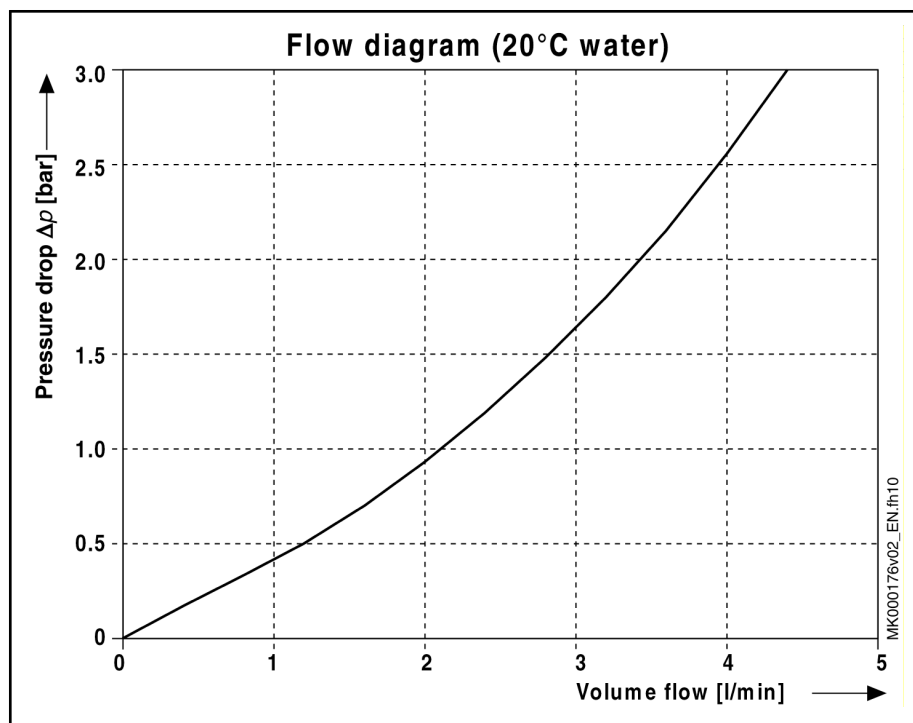

Fig. 9-14: Flow diagram for MSK motors



If a different coolant is used, a different coolant-specific flow diagram applies.

Selection of the cooling system

The motor power loss P_V transformed to heat is dissipated using the cooling water. Liquid-cooled motors may therefore only be operated via an externally connected cooling unit in order to guarantee the required coolant inlet temperature.



Cooling units are not supplied by Bosch Rexroth and must be dimensioned and provided by the customer. See also [chapter "Manufacturers of cooling units" on page 230](#).

Dimensioning

An effective heat loss dissipation is a prerequisite for achieving the specified motor data. The amount of heat loss in the motor is largely determined by the utilization rate of the motor. How well or how quickly the heat loss can be dissipated determines the performance of the motor.

The performance of the cooling unit or cooling system must therefore be designed in such a way that the resulting power loss of the motors can be dissipated at any time. If several motors are operated on one cooling system, this applies to the sum of the individual power losses. The required coolant pressure must also be able to be achieved at maximum volume flow.



The required cooling and pump capacity is calculated from the sum of the connected motors or heat carriers, the specified minimum flow rate and the pressure drop.

When designing and dimensioning the cooling system, observe the project planning "Liquid cooling from Rexroth drive components", MNR R911265836.

Operating conditions and application notes

- Cooling circuits** Generally, two different cooling circuits are used to cool the motors:
- closed cooling circuit (no penetration of oxygen possible)
 - semi-open cooling circuit (oxygen can only enter the cooling system through the pressure compensation vessel)



Open cooling systems with intensive oxygen contact are not allowed. Bosch Rexroth recommends to design the cooling circuits as closed systems in order to minimize system-wide bacterial growth.

The electrochemical processes occurring in the cooling system must be minimized by the selection of materials. Mixed installations, i.e. combinations of different materials such as copper, brass, iron, zinc and halogenated plastics (e.g. PVC hoses and seals) should be avoided.

Operating conditions and application notes

Potential equalization of the cooling system

Connect all components within the cooling system (e.g. motor, heat exchanger, pipe system, pump, pressure compensation container) with a potential equalization. The potential equalization must be carried out with a copper rail or copper strand with a corresponding conductor cross-section.

Cooling water pipes must never touch live parts. Ensure an insulation distance > 13 mm! All lines must be firmly fixed mechanically and checked for leaks at regular intervals.

Manufacturers of cooling units

The following table shows several manufacturers of cooling units. The list is not exhaustive and represents only a small number of cooling unit manufacturers. Of course, products of other manufacturers can be used.



However, the machine manufacturer is responsible for the suitability test for the cooling media used and the design of the liquid cooling system.

Bosch Rexroth does not claim any warranty for third-party products.

Rittal GmbH & Co KG	http://www.rittal.com
KKT Kraus Kälte- und Klimatechnik GmbH	http://www.kkt-chillers.com
Glen Dimplex Deutschland GmbH	http://www.riedel-cooling.com
BKW Kälte-Wärme-Versorgungstechnik GmbH	http://www.bkw-kuema.de
Hyfra Industriekühlanlagen GmbH	http://www.hyfra.de

Tab. 9-10: *Manufacturers of cooling units*

Coolants

The performance of the cooling system must be rated by the machine or coolant system manufacturer such that all requirements regarding flow, pressure, cleanliness, temperature gradient, etc. are maintained in every operating state.

The cooling medium must be provided by the customer. Water must be used as cooling medium. Water which is to be used as cooling water must comply with certain criteria and treated accordingly if necessary (see Fig. 9-11, [Quality of the cooling water](#)). Coolant additives must be admixed into the coolant for corrosion protection and chemical stabilization. The selected coolant additives must comply with the materials in the cooling system (e.g. copper, brass, stainless steel, etc.) and may not contain any environmentally hazardous substances.

A cooling with floating water from the supply network is not recommended. Normal water can be heavily calcified and cause sediments or corrosion within the cooling system. For any clues regarding composition of floating water, please refer to your local water supplier. Your manufacturer for coolant additives is on hand for further notes about necessary quality of the coolant water or additional water.



Should other coolant mediums than water be used, a performance reduction of the motor can be necessary to dissipate the created power loss within the cooling medium. In this case, please contact your Bosch Rexroth sales partner.

NOTICE

Impairment or failure of motor, machine or cooling system!

- For this reason, liquid cooled motors may only be operated as long as coolant supply is ensured.
- Observe the manufacturer's instructions when designing and operating cooling aggregates.
- Do not use coolants or cutting materials from machining processes for cooling.
- If the coolants, additives or cooling lubricants used are too aggressive, the motors may be damaged to an irreparable degree.

Quality of the cooling water

Requirements on the cooling water, especially with regard to the material compatibility must be adjusted with the manufacturer of coolant aggregates and the manufacturer of the coolant additives. Basically, the minimum requirements on the cooling water are shown in the following.

	Cooling water quality for motors with internal cooling circuit made of ...		
	Copper/brass	Aluminum pressure casting / steel	Stainless steel
pH-value (at 20 °C)	6 ... 9		
Total hardness	1.2 ... 1.8 mmol/l		1.2 ... 2.5 mmol/l
Concentration of chloride	< 40 ppm		< 150 ppm
Concentration of sulfate	< 50 ppm		< 200 ppm
Concentration of nitrate	< 50 ppm		
Part of dissolved materials	< 350 ppm		
Particle size of contaminations	≤ 100 µm		
Conductivity	< 50 µS/cm	< 500 µS/cm	< 2000 µS/cm

Tab. 9-11: Quality of the cooling water

Cleaning the coolant circuit

Inspect and clean (purge) the cooling system at regular intervals as specified in the machine and cooling system manufacturer's maintenance schedule.

Note that the utilization of unsuitable cleaning agents may cause irreversible damage to the motor cooling system. This type of damages does not lie within the responsibility of Bosch Rexroth.

NOTICE

Risk of damage to the motor cooling system by unsuitable cleaning agents! Loss of warranty!

- The only liquids or materials allowed to be used for cleaning and motor cooling are those which do not corrode the motor cooling system or do not react aggressively to the materials used in our motors.
- Observe the instructions of the manufacturers of the cleaning agent and the cooling system.

Coolant additives

Manufacturers of coolant additives

The following table shows several manufacturers of cooling aggregates (Fig. 9-12, [Manufacturers of chemical additives](#)) Of course, other products of other manufacturers can be used.

Operating conditions and application notes



The performance test for the used coolants and the design of the liquid coolant system are generally the responsibility of the machine manufacturer. The selected coolant additives must be compatible with the materials within the cooling system, to avoid e.g. electro-corrosion.

Observe the environmental protection and waste disposal instructions at the place of installation when selecting the coolant additives.

Nalco Deutschland GmbH	http://www.nalco.com
FUCHS PETROLUB AG	http://www.fuchs-oil.com
Clariant Produkte (Deutschland) GmbH	http://www.antifrogen.de
hebro chemie GmbH	http://www.hebro-chemie.de
TYFOROP Chemie GmbH	http://www.tyfo.de
Schweizer-Chemie GmbH	http://www.schweitzer-chemie.de

Tab. 9-12: *Manufacturers of chemical additives*

The proper chemical treatment is precondition to prevent corrosion, to maintain thermal transmission, and to minimize the growth of bacteria in all parts of the system.

In the following, the products of Nalco are exemplarily listed. Nalco makes different additives in form of "ready-to-use cooling water" and "water treatment kits" available, depending on the size of the cooling system.

The use of the following chemicals is designed for closed cooling systems and the following metallurgy.

- Stainless steel, aluminum, copper and non-ferrous metals

The packaging size and the ingredients of the water treatment kit are completely adapted to the corresponding system volume and the user may fill them into the coolant reservoir without observing further mixing ratios.

Ready-to-use cooling water (company NALCO)

System volume in liters	Ordering designation	Additives NALCO...
0,5 ... 50	Nalco CCL100.11R	CCL100

Tab. 9-13: *Ready-to-use cooling water (company NALCO)*

Cooling water NALCO CCL100

Nalco CCL100 is a ready-to-use, preserved cooling water for the use in closed cooling water systems. It is supplied directly to the closed systems and contains all reagents in the proper treatment concentration.

Nalco CCL100 contains a corrosion inhibitor protecting iron, copper, copper alloys and aluminum against corrosion. Nalco CCL100 is free of nitrite and minimizes the micro-biological growth.

Water treatment kits (company NALCO)

System volume in liters	Ordering designation	Additives NALCO...
50 ... 99	480-BR100-100.88	TRAC100 7330 73199
100 ... 199	480-BR100-200.88	
200 ... 349	480-BR100-350.88	
350 ... 500	480-BR100-500.88	

Tab. 9-14: *Water treatment kits (company NALCO)*

Operating conditions and application notes

Coolant Additive NALCO TRAC100 Nalco TRAC100 is a liquid corrosion and film inhibitor for the use in closed cooling systems. Optionally with TRASAR technology: it monitors, shows and dosages the product automatically to its target concentration and continuously protects the system. NALCO TRAC100 is a complete inhibitor protection iron metal, copper alloys and aluminum against corrosion. NALCO TRAC100 is free of nitrite and minimizes the requirements for micro-biological control.

Coolant additive NALCO 7330 Nalco 7330 is a non-oxidizing broad band biocide and suitable for application in closed cooling circuit systems.

Coolant additive NALCO 73199 Nalco 73199 is an organic corrosion inhibitor supporting a fast own protection layer and covering protection layer for non-ferrous metals.

The above additives are part of the preventive water treatment program by Nalco. It comprises not only the chemicals but also test methods, service and equipment. All these are made available to the user of the products.

For additional information and order placement, please contact Fa. Nalco.

Operating parameters

Inlet temperature Observe the specified temperature range and take into account the existing ambient temperature when setting the coolant inlet temperature.

 The coolant inlet temperature must be set in a temperature range of +10 ... +40 °C and is limited to no more than 5 °C under the existing ambient temperature to avoid condensation.

	Example 1:	Example 2:
Allowed coolant temperature setting range:	+10 ... +40 °C	+10 ... +40 °C
Ambient temperature:	+20 °C	+30 °C
Coolant inlet temperature to be set:	+15 ... +40 °C	+25 ... +40 °C

Operating pressure The maximum coolant inlet pressure of **6 bar** shall be applicable to all MSK motors. For motors manufactured before 2010-01-01 **FD 10W01** the inlet pressure must be limited to 3 bar.

Please observe that additional screw connections or junctions in the cooling circuit can have an influence on the flow and supply pressure of the cooling medium. The pressure drop Δp_n of the liquid-cooled motors is specified in the technical data.

 Monitoring systems for flow rate, pressure and temperature should be installed within the cooling circuit.

Operating conditions and application notes

9.13 Motor temperature monitoring

9.13.1 General information

The motor temperature is monitored by the two independently operating systems

- Temperature sensor
- Temperature model

and thus the highest possible protection of the motors against irreversible damage caused by thermal overload is ensured.

9.13.2 Temperature sensor

The monitoring of the motor temperature is ensured via the temperature sensor of the KTY84 type, which is built into the stator. The measured motor temperature is monitored for the following threshold values:

- Motor-warning temperature (140 °C)
- Motor shutdown temperature (150 °C)

The threshold values are stored in the encoder data memory of the MSK motors.

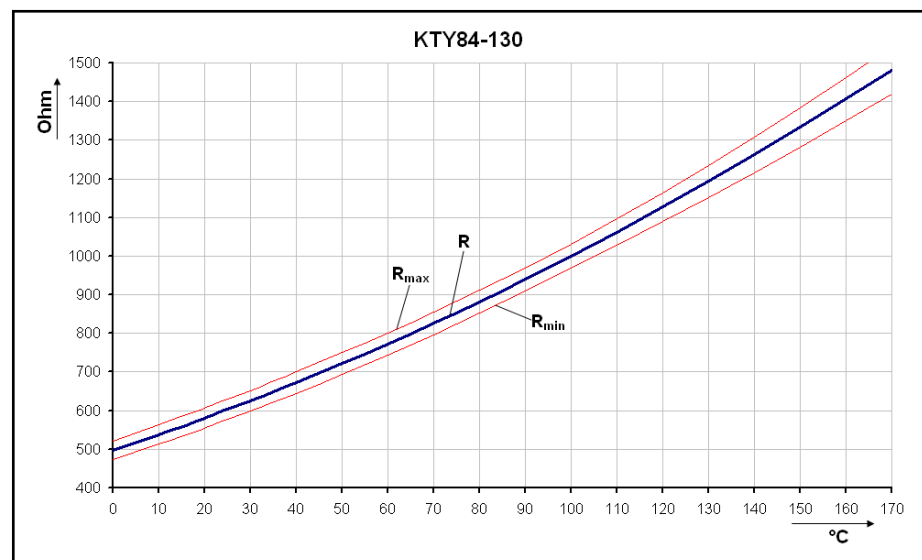

Fig. 9-15: Characteristic curve KTY84-130

The IndraDrive control devices monitor the functionality of the temperature sensors.

For more information, please refer to the functional description for IndraDrive controllers.

9.14 Operation on external controllers

Rate of rise of voltage The isolation system of the motor underlies a higher dielectric load in converter operation than in a sinusoidal source voltage only. The voltage stress of the winding isolation in converter operation is mainly defined by the following factors:

- Crest value of voltage
- Rise time of impulse on the motor terminal
- Switching frequency of converter output
- Length of power cable to the motor

Main components are the switching times of converter output and the length of the power cable to the motor. The occurred rates of rise of voltage on the motor may not exceed the specified limits from **DIN VDE 0530-25 (VDE 0530-25):2009-08 (picture 14, limit curve A)** of impulse voltage, measured on the motor terminals of two strands in dependence of the rise time.



Outputs of IndraDrive converters keep this limits.

10 Transport and storage

10.1 Transport Instructions

Transport our products only in their original package. Also observe specific ambient factors to protect the products from transport damage.

Based on EN 60721-3-2, the tables below specify classifications and limit values which are allowed for our products while they are transported by land, sea or air. Observe the detailed description of the classifications to take all of the factors which are specified in the particular class into account.

Allowed classes of ambient conditions during transport acc. to EN 60721-3-2

Classification type	Allowed class
Classification of climatic ambient conditions	2K2
Classification of biological ambient conditions	2B1
Classification of chemically active materials	2C2
Classification of mechanically active materials	2S2
Classification of mechanical ambient conditions	2M1

Tab. 10-1: Allowed classes of ambient conditions during transport

For the sake of clarity, a few essential environmental factors of the aforementioned classifications are presented below. Unless otherwise specified, the values given are the values of the particular class. However, Bosch Rexroth reserves the right to adjust these values at any time based on future experiences or changed ambient factors.

Allowed transport conditions

Environmental factor	Symbol	Unit	Value
Temperature	T_T	°C	-20 ... +80 ¹⁾
Air humidity (relative air humidity, not combinable with quick temperature change)	φ	%	75 (at +30 °C)
Occurrence of salt mist			Not permitted ¹⁾

1) Differs from EN 60721-3-2

Tab. 10-2: Allowed transport conditions



Before transport, empty the liquid coolant from the liquid-cooled motors to avoid frost damage.

Transport by air

If motor components with permanent magnets are shipped by air, the DGR (Dangerous Goods Regulations) of the IATA (International Air Transport Association) for hazardous materials of class 9 which also include magnetized substances and objects must be observed. For example, these regulations are applicable for

- Secondary parts of synchronous linear motors
- Rotors of synchronous kit motors
- Rotors of synchronous housing motors (if shipped as motor components, i.e., separated from the stator or motor housing in case service work is required)

For information on the maximum allowed magnetic strengths and methods of measuring such magnetic field strengths, please refer to the current IATA DGR (chapter 3.9.2.2).

Transport and storage

10.2 Storage instructions

10.2.1 Storage conditions

Generally, Bosch Rexroth recommends to store all components until they are actually installed in the machine as follows:

- In their original package
- At a dry and dustfree location
- At room temperature
- Free from vibrations
- Protected against light or direct insolation

On delivery, protective sleeves and covers may be attached to our motors. They must remain on the motor for transport and storage. Do not remove these parts until shortly before assembly.

Based on EN 60721-3-1, the tables below specify classifications and limit values which are allowed for our products while they are stored. Observe the detailed description of the classifications to take all of the factors which are specified in the particular classification into account.

Allowed classes of ambient conditions during storage acc. to EN 60721-3-1

Classification type	Class
Classification of climatic ambient conditions	1K2
Classification of biological ambient conditions	1B1
Classification of chemically active materials	1C2
Classification of mechanically active materials	1S1
Classification of mechanical ambient conditions	1M2

Tab. 10-3: Allowed classes of ambient conditions during storage

For the sake of clarity, a few essential environmental factors of the aforementioned classifications are presented below. Unless otherwise specified, the values given are the values of the particular class. However, Bosch Rexroth reserves the right to adjust these values at any time based on future experiences or changed ambient factors.

Allowed classes of ambient conditions during storage acc. to EN 60721-3-1

Environmental factor	Symbol	Unit	Value
Air temperature	T_L	°C	-20 ... +60 ¹⁾
Relative air humidity	φ	%	5 ... 95
Absolute air humidity	ρ_w	g/m ³	1 ... 29
Condensation	--	--	Not allowed
Ice formation/freezing	--	--	Not allowed
Direct solar radiation	--	--	Not allowed ¹⁾
Occurrence of salt mist	--	--	Not allowed ¹⁾

1) Differs from EN 60721-3-1

Tab. 10-4: Allowed storage conditions



Before re-storage, empty the liquid coolant from the liquid-cooled motors to avoid frost damage.

10.2.2 Storage times

Additional measures must be taken on commissioning to preserve proper functioning – irrespective of the storage time which may be longer than the warranty period of our products. However, this does not involve any additional warranty claims.

Motors

Bearing time / months			Measures for commissioning
> 1	> 12	> 60	
■	■	■	Visual inspection of all parts to be damage-free
■	■	■	Resurface the holding brake
	■	■	Check the electric contacts to verify that they are free from corrosion
	■	■	Let the motor run in without load for one hour at 800 ... 1000 rpm
	■	■	Measure insulation resistance. Dry the winding at a value of < 1kOhm per volt rated voltage.
		■	Exchange bearings
		■	Exchange encoders

Tab. 10-5: Measures before commissioning motors that have been stored over a prolonged period of time

Cables and Connectors

Bearing time / months			Measures for commissioning
> 1	> 12	> 60	
■	■	■	Visual inspection of all parts to be damage-free
	■	■	Check the electric contacts to verify that they are free from corrosion
		■	Visually inspect the cable jacket. Do not use the cable if you detect any abnormalities (squeezed or kinked spots, color deviations, ...).

Tab. 10-6: Measure before commissioning cables and connectors that have been stored over a prolonged period of time

11 Delivery condition, identification, handling

11.1 Delivery condition

11.1.1 General information

Upon delivery, MSK motors are packed in cartons or wooden boxes. Packing units on pallets are secured with straps.

⚠ CAUTION

Injuries due to uncontrolled movement of the retaining straps when cutting!

Maintain a sufficient distance and carefully cut the bandages.

Motor shaft and plug connections are provided with protective sleeves ex works. Only remove the protective sleeves immediately before starting assembly.

11.1.2 Factory inspection

Factory testing of MSK motors includes:

- | | |
|---------------------------|--|
| Electrical testing | <ul style="list-style-type: none">• High-voltage test• Insulation resistance test• Protective conductor connection• Winding resistance test |
| Mechanical testing | <ul style="list-style-type: none">• Concentricity and position tolerances of shaft end and mounting flange• Axial run-out of the flange surface to the shaft• Coaxiality of the centering edge to the shaft• Brake holding torque test (option) |

11.1.3 Customer inspection

Since all MSK motors are subjected to a standardized test procedure, high-voltage tests by the customer are not necessary. Repeated high-voltage tests can damage motors and components.

NOTICE

Destruction of motor components due to improperly executed high-voltage inspection! Invalidation of warranty!

Avoid repeated inspections.

Please observe the target values of the EN 60034-1.

Delivery condition, identification, handling

11.2 Identification

11.2.1 Scope of delivery

The total scope of a delivery is stated on the delivery note or shipping document. The scope of a delivery can be distributed over several packages. Each individual package can be identified with the attached shipping label. On receipt of the delivery, check that the goods delivered are in accordance with your order and the shipping documents.

Immediately notify your responsible Rexroth sales partner of any deviations.

Directly notify the carrier in case of noticeable transport damage.

11.2.2 Type plate

Each motor has an individual type plate containing the device designation and technical information. In addition, a second type plate is attached to the motor delivered.

If the original type plate on the motor is covered by a machine contour, use the second supplied type plate and attach it clearly visible on the machine. This type plate is either attached loosely to the motor or glued to the original type plate and can be removed.

The type plate is used for

- Identification of the motor
- Procurement of spare parts in case of malfunction
- Service information



The type designation of the motor is also stored in the encoder data memory.

Delivery condition, identification, handling

Motor type plate

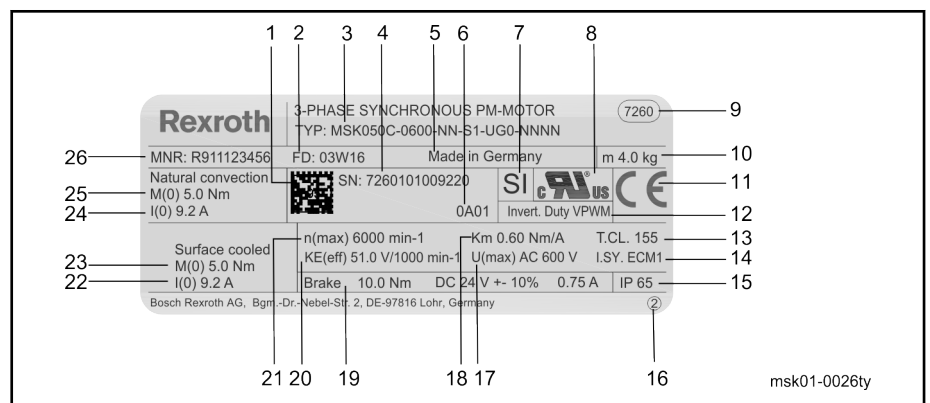

- 1 Barcode
- 2 Date of production
- 3 Motor type (ordering designation according to the type code)
- 4 Serial number
- 5 Country of origin
- 6 Revision state
- 7 Designation motor prepared for safety technique
- 8 Designation cURus (UL)
- 9 Factory number
- 10 Netto weight
- 11 CE conformity
- 12 Inverter Duty VPWM (UL)
- 13 Thermal temperature class
- 14 Designation isolation system (UL)
- 15 Degree of protection housing
- 16 Type plate designation
- 17 Voltage class (UL)
- 18 Torque constant at 20°C
- 19 Data about holding brake, optional (holding brake, rated voltage, rated current)
- 20 Voltage constant
- 21 Maximum velocity
- 22 Standstill current (surface or liquid)
- 23 Standstill torque (surface or liquid)
- 24 Continuous current at standstill 60K
- 25 Continuous torque at standstill 60K
- 26 Part number

Fig. 11-1: Type plate MSK

Delivery condition, identification, handling

11.3 Handling

⚠ CAUTION

Injuries due to improper handling during transport of motors!

Do only use suitable lifting devices (e.g. lifting sling belts, eyebolts, chain suspension ...).

Use protective equipment and personal protective clothing (gloves, safety shoes, ...).

Never walk under hanging loads.

NOTICE

Damage of property and invalidation of the warranty due to incorrect storage!

Store the motors horizontally in their original packaging in a dust-free, dry, vibration-free and sun-protected environment.

Observe the storage and transport instructions on the package.

Handling

On delivery, MSK motors are protected by shaft protection and covers. Covers and shaft protection must remain on the motor during transport and storage.

- Do not remove covers and shaft protection until immediately before installation.
- Use covers and shaft protection also when returning goods.
- Avoid damage to the motor flange and drive shaft.

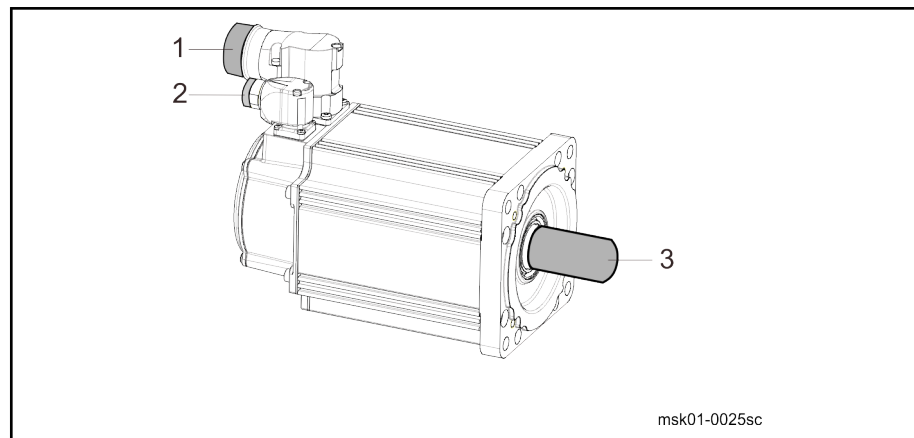

- ① Cable connector cover
- ② Encoder connector cover
- ③ Shaft protection

Fig. 11-2: Covers and shaft protection

NOTICE

Motor damage due to beats onto the motor shaft

Do never beat onto the shaft end and do not exceed the allowed axial and radial forces of the motor.

Transport

Observe the following points during transport:

Delivery condition, identification, handling

- Use suitable means of transport and take into account the weight of the components (weight specifications can be found in the data sheets or on the type plate of the motor).
- Use suitable shock absorbers if heavy vibrations can occur during transport.
- Transport the motors in a horizontal position only.
- Use cranes with loop lifting straps to lift the motors.

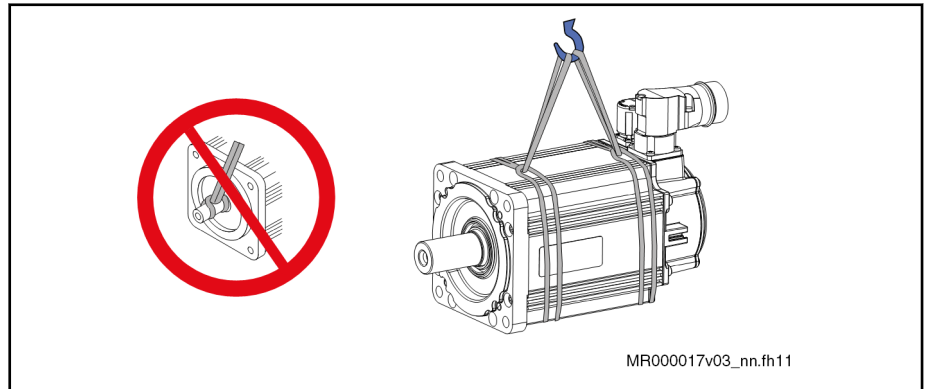

Fig. 11-3: *Lifting and transporting the motors with the aid of loop lifting belts*

12 Installation

12.1 Safety

⚠ WARNING

Danger! Electric voltage! Operations in the vicinity of live parts are extremely dangerous.

Work required on the electric system may only be carried out by skilled electricians. Tools for electricians (VDE tools) are absolutely necessary.



Prior to commencing work:

1. Isolate (even auxiliary circuits).
2. Protect the system or plant against restart.
3. Ensure de-energization.
4. Ground and short-circuit.
5. Cover or shield any adjacent live parts.

Before starting to work, check with an appropriate measuring device whether parts of the system are still under residual voltage (e.g. caused by capacitors, etc.). If yes, wait until these parts have discharged.

⚠ CAUTION

Injuries due to improper handling during transport of motors!

Do only use suitable lifting devices (e.g. lifting sling belts, eyebolts, chain suspension ...).

Use protective equipment and personal protective clothing (gloves, safety shoes, ...).

Never walk under hanging loads.

Carry out all work steps with particular care. This minimizes the risk of accidents and damage.

Installation

12.2 Specialist personnel

All work on the system and the drives may only be carried out by suitably trained specialist personnel.

Make sure that all persons who carry out

- installation work
- maintenance work or
- operating work

on the system are sufficiently familiar with the contents, all warnings and precautions according to this documentation.



Qualified specialist personnel are trained, instructed or authorized to switch circuits and devices on and off as well as to ground and to mark them according to the regulations of safety engineering. Qualified personnel have adequate safety equipment and are trained in first aid.

12.3 Mechanical attachment

12.3.1 Flange attachment

The screw connection must be adapted to the installation situation (screw length, strength class, screw-in depth, material, ...) The dimensioning of the screw connection is the responsibility of the customer.

Rexroth recommends the following screws and washers for attaching the motors to the machine in a professional and safe manner.

Fixing screws MSK motors

Boring ø [mm]	Screw 8.8 DIN EN ISO 4762 DIN EN ISO 4014	Tightening torque M _A [Nm] at μ _K = 0.12	Washer DIN EN ISO 28738
4.5	M4 × 20	3	-
6.6	M6 × 20	10.1	-
9	M8 × 20	24.6	yes
11	M10 × 30	48	yes
14	M12 × 40	84	yes
18	M16 × 35	206	yes

Tab. 12-1: Mounting screws tightening torque



The bolted connections for flange mounting must be able to absorb both the weight force of the motor and the forces occurring during operation.

If screws and washers that deviate from this recommendation are used, the strength class of the screws and the hardness class of the washers must be equivalent in order to transmit the required tightening torques.

MSK motors are manufactured ex works for flange mounting (B05). Details on the mounting holes are contained in the respective dimension sheet.

12.3.2 Foot attachment

The foot attachment only is available for MSK133.

The screw connection must be adapted to the installation situation (screw length, strength class, screw-in depth, material, ...) The dimensioning of the screw connection is the responsibility of the customer.

Mounting screws MSK133 foot attachment

Motor	Boring ø [mm]	Screw	Washer
MSK133-...-NPNN	12	M10	Yes

Tab. 12-2: Mounting screws tightening torque

Foot mounting

Before attaching the MSK133 by means of foot mounting, observe the specified distance from the center of the motor shaft to the lower edge of the foot in the respective motor dimension sheet. Compare this dimension with the connection dimension on the machine side.

Installation



The mounting holes and clearances correspond to the general tolerance according to ISO 2768-m.

Before attaching the motor to the machine, it must be aligned so that the center line of the motor shaft is aligned with the center line of the connecting shaft.

Also note the information on this mounting type provided in [chapter 9.3 "Design and installation positions" on page 208](#).

The following procedure is recommended for foot mounting of the motors:

1. MSK133: remove the lower side air baffles to gain free access to the mounting holes.
2. Align the motor so that the center line of the motor shaft is aligned with the center line of the machine connecting shaft. To align the motor, use sheet steel strips as a base.
3. Connect the motor firmly to the machine (for tightening torques, see [tab. 12-1 "Mounting screws tightening torque " on page 249](#)).
4. MSK133: replace the initially dismantled air baffles on the motor.

Frame size	Motor attachment type	Number of mounting holes	Surface roughness of the screw-on surface to the machine
133	Foot plates (2 pieces)	4	Rz32

Tab. 12-3: Overview foot mounting

12.3.3 Preparation

Prepare the motor mounting as follows:

1. Procure tools, auxiliary materials, measuring and testing equipment.
2. Check all components for visible damage. Damaged components must not be mounted.
3. Make sure that all system dimensions and tolerances are suitable for motor mounting (see dimension sheet for details).
4. Check all components, mounting surfaces and threads for cleanliness.
5. Ensure that installation can be carried out in a dry, dust-free environment.
6. Make sure that the holder for the motor flange is free of burrs.
7. Remove the protective sleeve from the motor shaft and keep the sleeve for future use.
8. Only for motors with holding brake

Check whether the motor holding brake reaches the holding torque specified in the data sheet. If the brake does not reach the specified torque, first loop in the holding brake at [chapter 9.10.4 "Holding brake - commissioning and maintenance instructions" on page 223](#).

12.3.4 Motor mounting

Mount the motor and pay attention:

1. Avoid clamping or jamming the centering collar on the motor side.
2. Avoid damaging the holder on the system side.
3. Connect the motor to the machine and observe the tightening torques.
4. Check strength and accuracy of connection before proceeding.

Installation

After proper mechanical assembly, carry out the electrical connection.

Installation

12.4 Electrical connection - connect motor

12.4.1 General information

Preferably use ready-made connection cables from Rexroth. These cables offer numerous advantages, such as UL/CSA approval, extreme load capacity and resistance as well as EMC-compliant design.

⚠ WARNING

Danger! Electric voltage! Operations in the vicinity of live parts are extremely dangerous.

Work required on the electric system may only be carried out by skilled electricians. Tools for electricians (VDE tools) are absolutely necessary.



Prior to commencing work:

1. Isolate (even auxiliary circuits).
2. Protect the system or plant against restart.
3. Ensure de-energization.
4. Ground and short-circuit.
5. Cover or shield any adjacent live parts.

Before starting to work, check with an appropriate measuring device whether parts of the system are still under residual voltage (e.g. caused by capacitors, etc.). If yes, wait until these parts have discharged.

⚠ WARNING

Damage to persons or property by disconnecting or connecting energized connectors!

- Connect and disconnect connectors only when they are dry and de-energized.
- During operation of the system, all connectors must be securely tightened or locked.

⚠ WARNING

Risk of short-circuit caused by liquid coolant, lubricant or pollution! Short-circuits of live lines may cause unpredictable dangerous situations or lead to damage to property.

When installing or replacing drive components, provide open sides of power connectors with protective caps.

Do only open terminal boxes for connection purpose and close them immediately after the connection is done.

12.4.2 Connecting the plug-in connector

Power, encoder connector Proceed as follows to connect the threaded connectors:

1. Place the power connector on the thread of the terminal box in the correct position.
2. Tighten the cap nut of the power connector by hand. By feeding more cable, the power connector can be brought up to its end position.
3. Tighten the cap nut up to the stop.



Only fully tightened cap nuts guarantee the specified protection against water (IP65) and activate the vibration protection.

Set output direction (option "U")

For MSK motors, the output direction of the connected power and encoder cables can be set with the option Electrical connection "U". The adjustable flange sockets can be rotated in a range of 240°, see [chapter 8.4 "Plug connector, rotatable" on page 196](#).

The flange socket can be rotated if an appropriate plug-in connector has been connected. The flange socket can be brought into the desired position by hand due to the lever effect of the connected plug-in connector.

1. Connect plug-in connector to flange socket
2. Move the flange socket in the desired output direction by turning the connected plug-in connector.



Do not use any tools (e.g. pliers or screwdrivers) to turn the motor flange socket. Mechanical damage to the flange socket by tools cannot be ruled out.

The desired output direction is set.



Each rotation of the flange socket reduces the holding torque in the set position. Change the output direction no more than 5 times.

Select output direction (option "A, B, L, R")

The output direction of the connected power cables can be selected for MSK motors with the option Electrical connection "A, B, L, R" when ordering. The output direction of the encoder connectors cannot be changed for these motors.

Installation

12.5 MSK133 with terminal box type RLK1200, RLK1300

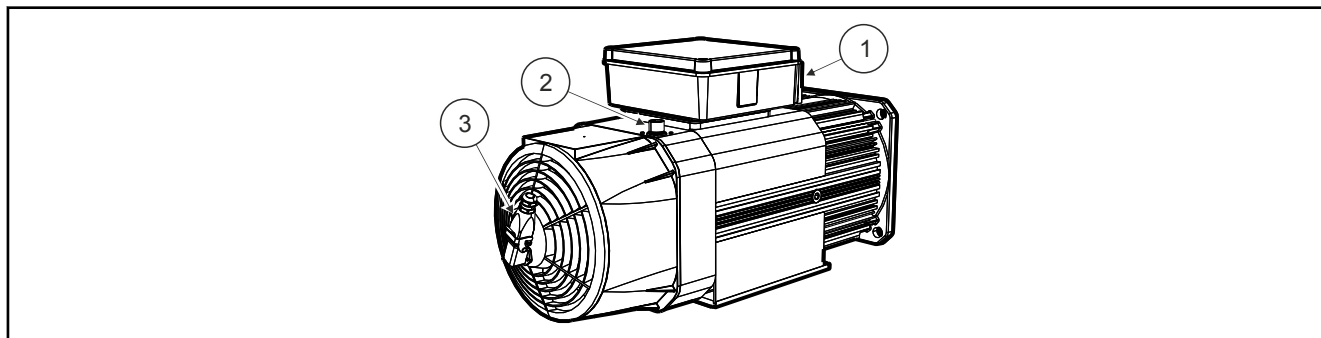

- 1 Power connection terminal box RLK1200 / RLK1300
 2 Encoder connection plug-in connector RGS1001
 3 Fan connection plug-in connector (provided, to be connected on-site)

Fig. 12-1: MSK133

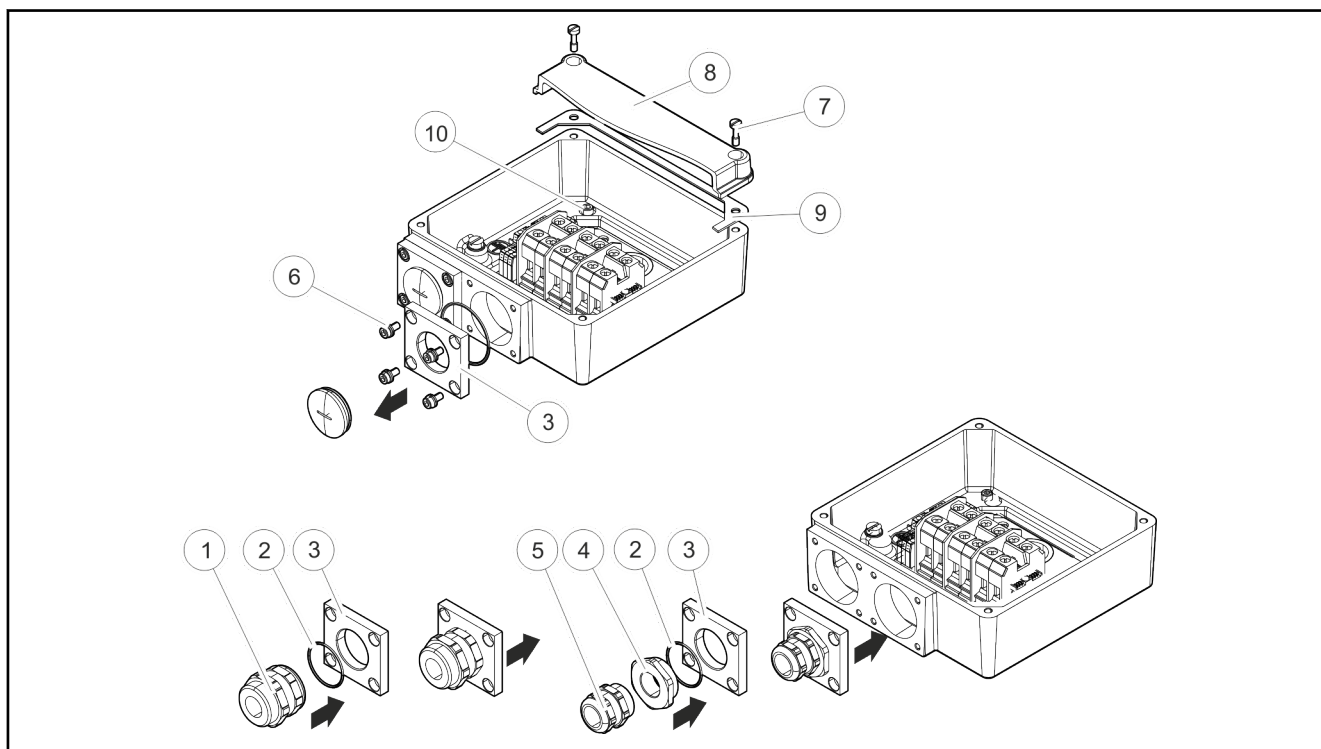

- ①⑤ Screw connection
 ② O-ring
 ③ Adapter plate for holding the screw connection, reduction, extension
 ④ Reduction (optional for cable cross-sections 1.5, 2.5 mm²), extension (optional for RLK1200 / 16 mm²)
 ⑥ Adapter plate mounting screws
 ⑦ Cover screws
 ⑧ Cover
 ⑨ Seal of terminal box cover
 ⑩ Mounting screws of terminal box (4 pieces)

Fig. 12-2: Assembly RKL 1200, RKL 1300

Power cable connection on terminal box

The power connection is made in single or double wiring. The ready-made power cables are inserted into the terminal box via the adapter plates and cable glands with optional reductions/extensions.

Connecting the power cable to the terminal box requires the following steps:

1. Open the terminal box cover.
Loosen and remove the mounting screws (4 pieces).
2. Turn terminal box if necessary.
Loosen the mounting screws ⑩ and turn the terminal box by 90 or 180 degrees. Screw in and tighten the mounting screws ⑩ . Tightening torque of the screws ⑩: 6.5 Nm (± 10%)
Ensure that the seal between the terminal box and motor housing is in proper condition and in the correct position.
3. Remove the protective cover of the cable gland.
4. Detach the adapter plate ③ from the terminal box.
5. Screw the adapter plate firmly to the metric cable gland on the power cable. Use reduction for power core cross-sections of 1.5 mm² and 2.5 mm².
Before attaching the power cable to the adapter plate, check the correct condition and position of the O-ring.
6. Feed the power cable up to the adapter plate through the opening in the terminal box and fasten the adapter plate to the terminal box.
Tightening torque of the screws ⑥: 9 Nm (±10%)
Before attaching the adapter plate ⑥ to the terminal box, check the O-ring ⑤ inserted in the adapter plate for proper condition and correct position.
7. Connect the cores according to the connection diagram for standard or double cabling.

Observe the following tightening torques:

Designation	Type	Connection mm ²	Size / type	Tightening torque Nm
Clamping power U1, V1, W1	WEF	1.5 ... 16 (RLK1200) 1.5 ... 35 (RLK1300)	M6	2.5
Clamping 1 ... 6 temperature sensor / holding brake (option)	WEF	0.2 ... 2.5	Spring-cage terminal	-
Ring terminal end for PE and screen	RTE		M8	3.8
WEF = wire end ferrules RTE = ring terminal end				

Tab. 12-4: Screw tightening torques in Nm in terminal box

8. Close and fasten the terminal box cover.
Apply Loctite 243 (liquid screwlock) to the thread of the mounting screws for the lid ① and then attach the lid with all of the mounting screws.
Tightening torque of the screws: 6.5 Nm (±10%)
Before attaching the terminal box cover to the terminal box, check for proper condition and the correct position of the glued seal ② on the terminal box cover.

Installation

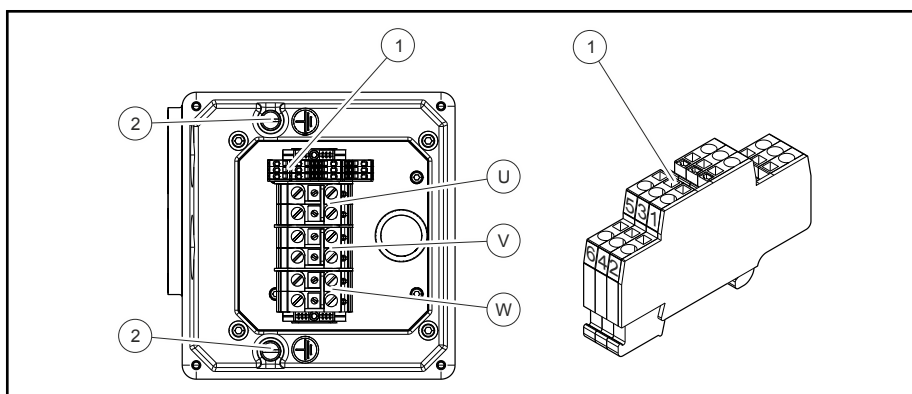

- ① Terminal strip (brake, temperature sensor)
- ② Protective conductor terminal
- ⓪ Ⓛ Ⓜ Power connection

Fig. 12-3: Connection points

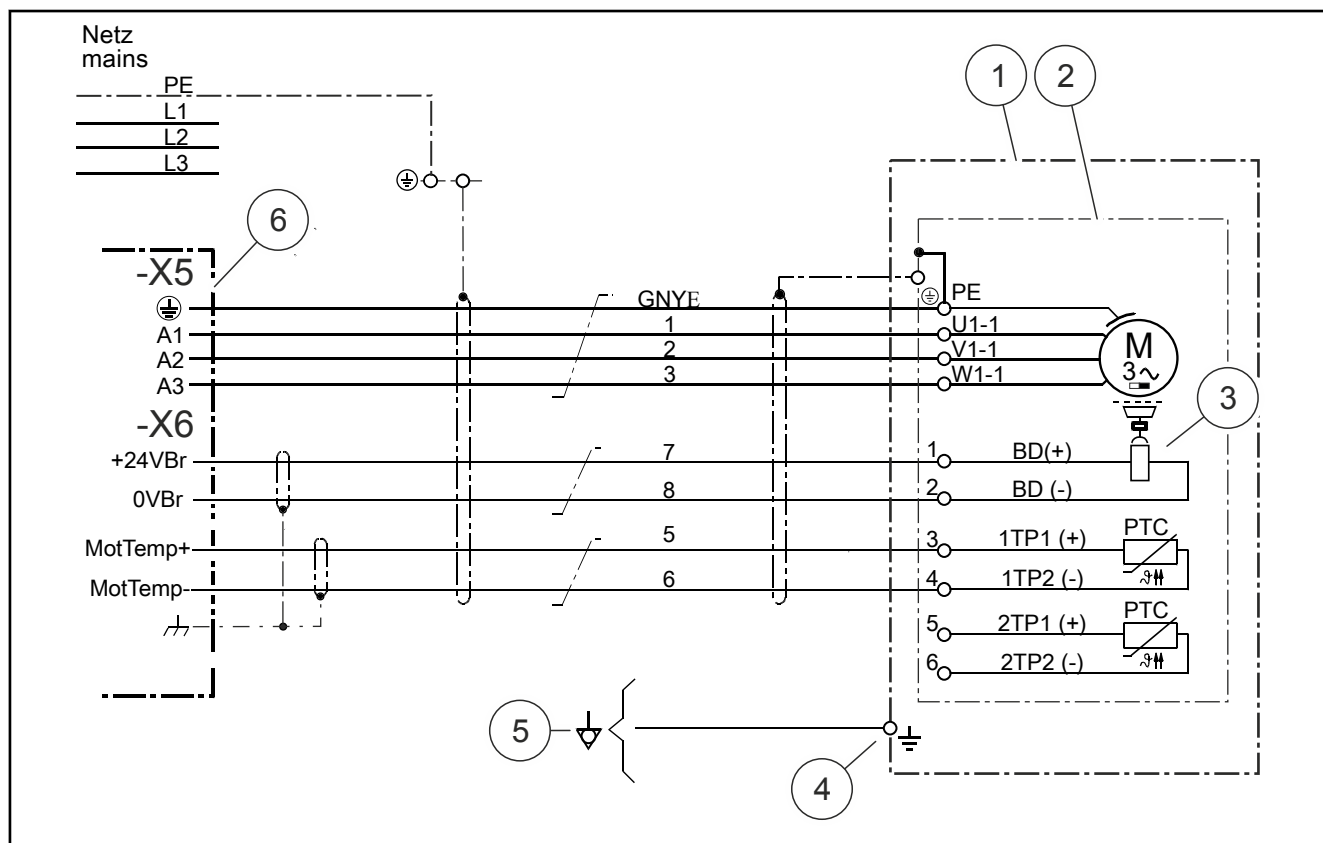

- ① Motor housing
- ② Terminal box
- ① Holding brake (option)
- ④ Equipotential bonding connection at the motor (only available on ATEX motors)
- ⑤ Equipotential bonding connection at the machine (required for ATEX motors)
- ⑥ Rexroth drive controller

Fig. 12-4: Connection diagram terminal box individual wiring RLK1200, RLK1300



The connection diagram represents a possible connection. Observe the valid installation regulations at the installation site of the machine.

13 Commissioning, operation and maintenance

13.1 Commissioning

CAUTION

Damage to property due to errors in the controls of motors and moving elements! Unclear operating states and product data!

Do not perform a commissioning, if ...

- the connections, operating states or product data are unclear or faulty.
- the safety equipment and monitoring of the system is damaged or not in operation.

Never use any damaged products.

Contact Rexroth for missing information or support during commissioning.

The following commissioning notes refer to MSK motors as part of a drive system with drive controller and control unit.

Preparation

1. Have the documentations of all products used ready at hand.
2. Check the products for damage.
3. Check all mechanical and electrical connections.
4. Enable the safety devices and monitoring systems of the machine.
5. Ensure that the optional holding brakes are ready for operation (see [chapter 9.10 "Holding brakes" on page 221](#)).

Procedure

Once all requirements are met, proceed as follows:

1. Enable the optional motor cooling fan unit or liquid cooling.
2. Perform the commissioning of the drive system according to the instructions in the respective product documentation. The corresponding information can be found in the functional descriptions of the drive control units.



The commissioning of control units and control systems may require further steps. Testing the functionality and performance of the systems is not part of the motor commissioning, but is carried out as part of the overall commissioning of the machine. Observe the information and instructions of the machine manufacturer.

Commissioning, operation and maintenance

13.2 Operation

During operation, ensure that the ambient conditions described are observed (see [chapter 9 "Operating conditions and application notes"](#) on page 203).

13.3 Shutdown

In the event of malfunctions, maintenance measures or shutting down the motors, please proceed as follows:

1. Follow the instructions in the machine documentation.
2. Use the machine-side control commands to decelerate the drive to a controlled standstill.
3. Switch off the power and control voltage of the control unit.
4. **Only for motors with fan unit:** Switch off the motor protection switch for the fan unit.
5. Switch off the main switch of the machine.
6. Secure the machine against unpredictable movements and against operation by unauthorized persons.
7. Wait until the discharging time of the electrical systems has elapsed and then disconnect all electrical connections.
8. Before disassembling the motor and, if applicable, the fan unit, secure them against dropping or moving and afterwards, disconnect the mechanical connections.

13.4 Maintenance

13.4.1 General information

MSK motors operate maintenance-free within the specified operating conditions and service life. Operation under unfavorable conditions can, however, lead to restrictions in availability.

Increase availability with regular preventive maintenance measures. Observe the information of the machine manufacturer in the machine maintenance plan and the maintenance measures described in the following.

⚠ WARNING

Danger! Electric voltage! Operations in the vicinity of live parts are extremely dangerous.

Work required on the electric system may only be carried out by skilled electricians. Tools for electricians (VDE tools) are absolutely necessary.



Prior to commencing work:

1. Isolate (even auxiliary circuits).
2. Protect the system or plant against restart.
3. Ensure de-energization.
4. Ground and short-circuit.
5. Cover or shield any adjacent live parts.

Before starting to work, check with an appropriate measuring device whether parts of the system are still under residual voltage (e.g. caused by capacitors, etc.). If yes, wait until these parts have discharged.

⚠ CAUTION

Combustions via hot surface with temperatures over 60 °C

Let the motor cool down, before maintenance. The thermal time constant stated in the technical data is a measure for the cooling time. A cooling time up to 140 minutes can be necessary!

Use safety gloves.

Do not work on hot surfaces.

⚠ WARNING

Personal and material damage during maintenance work in operation!

Never carry out maintenance work on running machines.

Before starting maintenance work, secure the machine against switching on, operation and unauthorized use.

13.4.2 Cleaning

Excessive dirt, chips or dust can negatively influence the motor functions. In extreme cases lead to motor loss. Clean the cooling fins of the motors at regular intervals (after one year at the latest) to reach a sufficiently high heat emission surface. If the cooling fins are partially covered with dirt, sufficient heat dissipation via the ambient air is no longer ensured.

Insufficient heat dissipation can have undesirable consequences. The bearing life is reduced by operation at inadmissibly high temperatures (bearing grease decomposes). Overtemperature switch-off despite operation on the basis of selected data, because the appropriate cooling is missing.

Commissioning, operation and maintenance

13.4.3 Bearings

The nominal lifetime of the bearings is $L_{10h} = 30,000$ h according to DIN ISO 281, ed. 1990, provided the permissible radial and axial forces are not exceeded.

The motor bearings should be replaced if

- the nominal bearing service life has been reached,
- running noises occur.



We recommend that bearings be replaced by the Bosch Rexroth Service.

13.4.4 Connecting cables

⚠ DANGER

Death by electrocution possible due to live parts!

If the slightest defect is detected in the cable sheath, the system must be shut down immediately. Then the cable must be replaced.

Do not repair any connection lines provisionally.

- Check connection cables for damage at regular intervals and replace them, if necessary.
- Check any optional energy management chains (drag chains) for defects.
- Check the protective conductor connection for proper state and tight seat at regular intervals and replace it, if necessary.

13.5 Information in case of malfunctions

⚠ WARNING

Fatal electric shock from live parts with more than 50 V!

Before starting work on live parts: Disconnect the machine from the power supply and secure the mains switch against unintentional or unauthorized re-connection.

Check whether the voltage has fallen below 50 V before touching live parts!

⚠ WARNING

Combustions via hot surface with temperatures over 100 °C

Let the motor cool down, before maintenance. The thermal time constant stated in the technical data is a measure for the cooling time. A cooling time up to 140 minutes can be necessary!

Do not work on hot surfaces.

Use safety gloves.

In the event of faults, always observe the information in the project planning and commissioning instructions. If necessary, contact the manufacturer [chapter 16 "Service and support" on page 273](#).

Malfunction	Error cause	Measures
Motor does not run	Controller enable signal missing	Activate controller enable signal
	Controller fault	Troubleshoot acc. to documentation of controller
	Voltage supply missing	Control voltage supply
	Brake is not released	Check the brake activation
Vibrations	Coupling elements or attachments are poorly balanced	Re-balance
	Adjustment of shaft end attachments (coupling, gearbox, ...) is insufficient	Re-align the attachments
	Mounting screws loose	Lock screw connections acc. to specifications
Running noise	Foreign bodies within the motor	Stop the motor --> repair by manufacturer
	Bearing is damaged	Stop the motor --> repair by manufacturer
High motor temperatures Motor temperature monitoring is activated	Operation outside the parameters	Reduce load
	Heat dissipation obstructed	Clean the motor For fan units, clean fan grille and check the fan function For liquid cooling, check cooling circuit.

Commissioning, operation and maintenance

Malfunction	Error cause	Measures
Wrong or defective temperature display	Temperature sensor not connected	Connect temperature sensor
	Temperature sensor defective	Stop the motor --> repair by manufacturer

Tab. 13-1: Malfunctions in MSK motors

13.6 Disassembly

⚠ WARNING

Personal injury and material damage during assembly works!

- Do not work on running or unsecured machines.
 - Before starting work, secure the machine against unpredictable movements and against unauthorized operation.
 - Before disconnecting the mechanical connections, secure the motor and supply lines against falling.
-

⚠ CAUTION

Combustions via hot surface with temperatures over 60 °C

Let the motor cool down, before maintenance. The thermal time constant stated in the technical data is a measure for the cooling time. A cooling time up to 140 minutes can be necessary!

Use safety gloves.

Do not work on hot surfaces.

- Follow the instructions in the machine documentation.
- Observe the safety instructions.
- Dismount the motor from the machine. Store the motor properly.

14 Environmental protection and disposal

14.1 Environmental protection

Production processes	The products are made with energy- and resource-optimized production processes which allow re-using and recycling the resulting waste. We regularly try to replace pollutant-loaded raw materials and supplies by more environment-friendly alternatives.														
No release of hazardous substances	Our products do not contain any hazardous substances which may be released in the case of appropriate use. Normally, our products will not have any negative influences on the environment.														
Significant components	Basically, our products contain the following components: <table><tr><td>Electronic devices</td><td>Motors</td></tr><tr><td>• steel</td><td>• steel</td></tr><tr><td>• aluminum</td><td>• aluminum</td></tr><tr><td>• copper</td><td>• copper</td></tr><tr><td>• synthetic materials</td><td>• brass</td></tr><tr><td>• electronic components and modules</td><td>• magnetic materials</td></tr><tr><td></td><td>• electronic components and modules</td></tr></table>	Electronic devices	Motors	• steel	• steel	• aluminum	• aluminum	• copper	• copper	• synthetic materials	• brass	• electronic components and modules	• magnetic materials		• electronic components and modules
Electronic devices	Motors														
• steel	• steel														
• aluminum	• aluminum														
• copper	• copper														
• synthetic materials	• brass														
• electronic components and modules	• magnetic materials														
	• electronic components and modules														

14.2 Disposal

Return of products	Our products can be returned to our premises free of charge for disposal. It is a precondition, however, that the products are free of oil, grease or other dirt. Furthermore, the products returned for disposal must not contain any undue foreign material or foreign components. Send the products "free domicile" to the following address: <p style="text-align: center;">Bosch Rexroth AG Electric Drives and Controls Buergermeister-Dr.-Nebel-Strasse 2 97816 Lohr am Main, Germany</p>
Packaging	The packaging materials consist of cardboard, wood and polystyrene. These materials can be recycled anywhere without any problem. For ecological reasons, please refrain from returning the empty packages to us.
Batteries and accumulators	Batteries and accumulators can be labeled with this symbol.  The symbol indicating "separate collection" for all batteries and accumulators is the crossed-out wheeled bin. The end user within the EU is legally obligated to return used batteries. Outside the validity of the EU Directive 2006/66/EC keep the stipulated directives. Used batteries can contain hazardous substances, which can harm the environment or the people's health when they are improperly stored or disposed of. After use, the batteries or accumulators contained in Rexroth products have to be properly disposed of according to the country-specific collection.
Recycling	Most of the products can be recycled due to their high content of metal. In order to recycle the metal in the best possible way, the products must be disassembled into individual modules.

Environmental protection and disposal

Metals contained in electric and electronic modules can also be recycled by means of special separation processes.

Products made of plastics can contain flame retardants. These plastic parts are labeled according to EN ISO 1043. They have to be recycled separately or disposed of according to the valid legal requirements.

15 Appendix

15.1 EU Declaration of conformity

In accordance with

Low Voltage Directive 2006/95/EC (valid until April 19, 2016)

Low Voltage Directive 2014/35/EU (valid from April 20, 2016)

the manufacturer,

Bosch Rexroth AG

Bürgermeister-Dr.-Nebel-Straße 2

97816 Lohr am Main, Germany

declares that the following products

3-PHASE SYNCHRONOUS PM-MOTOR				
MSK030...	MSK040...	MSK043...	MSK050...	MSK060...
MSK061...	MSK070...	MSK071...	MSK075...	MSK076...
MSK100...	MSK101...	MSK103...	MSK131...	MSK133...

from the date of manufacture 2009-01-08 were developed, designed and manufactured in compliance with the above-mentioned EU directives.

The sole responsibility for drawing up this declaration of conformity lies with the manufacturer.

Applied harmonized standards:

Standard	Title	Edition
EN 60034-1 (IEC 60034-1)	Rotating electrical machines - Part 1: Rating and performance	2010 + Cor.:2010 (2010, modified)
EN 60034-5 (IEC 60034-5)	Rotating electrical machines - Part 5: Degrees of protection provided by in- tegral design of rotating electrical ma- chines (IP-Code) - Classification	2001 + A1:2007 (2000 + Corrigen- dum 2001 + A1:2006)

Appendix



EU-Konformitätserklärung - Original

Dok.-Nr.: DCTC-30318-001

Datum: 2018-02-02

- nach Maschinenrichtlinie 2006/42/EG
 nach Niederspannungsrichtlinie 2006/95/EG (gültig bis 19. April 2016)
 nach Niederspannungsrichtlinie 2014/35/EU (gültig ab 20. April 2016)
 nach EMV-Richtlinie 2014/30/EU
 nach ATEX-Richtlinie 2014/34/EU

Hiermit erklärt der Hersteller,
Bosch Rexroth AG
Bürgermeister-Dr.-Nebel-Straße 2
97816 Lohr am Main / Germany,

dass die nachstehenden Produkte

Bezeichnung: 3-PHASE SYNCHRONOUS PM-MOTOR

Baureihen: MSK030... MSK040... MSK043... MSK050... MSK060...
MSK061... MSK070... MSK071... MSK075... MSK076...
MSK100... MSK101... MSK103... MSK131... MSK133...

Ab Herstellungsdatum: 2009-01-08

in Übereinstimmung mit den oben genannten EU-Richtlinien entwickelt, konstruiert und gefertigt wurden.
Die alleinige Verantwortung für die Ausstellung dieser Konformitätserklärung trägt der Hersteller.

Angewandte harmonisierte Normen:

Norm	Titel	Ausgabe
EN 60034-1 (IEC 60034-1)	Drehende elektrische Maschinen – Teil 1: Bemessung und Betriebsverhalten	2010 + Cor.:2010 (2010, modifiziert)
EN 60034-5 (IEC 60034-5)	Drehende elektrische Maschinen – Teil 5: Schutzarten aufgrund der Gesamtkonstruktion von drehenden elektrischen Maschinen (IP-Code) –Einteilung	2001 + A1:2007 (2000 + Corrigendum 2001 + A1:2006)

Lohr am Main , den 2018-02-02 ppa.
Ort Datum

Joachim Hennig
Werkleitung LoP2

Eberhard Schemm
Entwicklungsbereichsleiter Antriebe

i.V.
Entwicklungsbereichsleiter Antriebe

Änderungen im Inhalt der EU-Konformitätserklärung sind vorbehalten. Derzeit gültige Ausgabe auf Anfrage.





EU declaration of conformity - original

Doc. No.: DCTC-30318-001

Date: 2018-02-02

- in accordance with Machinery Directive 2006/42/EC
- in accordance with Low Voltage Directive 2006/95/EC (valid until 19th April, 2016)
- in accordance with Low Voltage Directive 2014/35/EU (valid from 20th April, 2016)
- in accordance with EMC Directive 2014/30/EU
- in accordance with ATEX Directive 2014/34/EU

The manufacturer,
Bosch Rexroth AG
Bürgermeister-Dr.-Nebel-Straße 2
97816 Lohr am Main / Germany

hereby declares that the products below

Name: 3-PHASE SYNCHRONOUS PM-MOTOR

Series: MSK030... MSK040... MSK043... MSK050... MSK060...
MSK061... MSK070... MSK071... MSK075... MSK076...
MSK100... MSK101... MSK103... MSK131... MSK133...

From the date of manufacture: 2009-01-08

were developed, designed and manufactured in compliance with the above-mentioned EU directives.
This declaration of conformity is issued under the sole responsibility of the manufacturer.

Harmonized Standards applied:

Standard	Title	Edition
EN 60034-1 (IEC 60034-1)	Rotating electrical machines – Part 1: Rating and performance	2010 + Cor.:2010 (2010, modified)
EN 60034-5 (IEC 60034-5)	Rotating electrical machines – Part 5: Degrees of protection provided by integral design of rotating electrical machines (IP code) - Classification	2001 + A1:2007 (2000 + Corrigendum 2001 + A1:2006)

Lohr am Main , dated 2018-02-02
Place Date

ppa 
Joachim Hennig
Plant Manager LoP2

i.V. 
Eberhard Schemm
Head of Development Drives Solutions

We reserve the right to make changes to the content of the EU Declaration of Conformity. Current issue on request.



2018-07-27 - SOCOS

© Bosch Rexroth AG 2018

DCTC-30318-001_KOE_N_EN_2018-02-02.docx

Fig. 15-2: EU Declaration of conformity - original, English

16 Service and support

Our worldwide service network provides an optimized and efficient support. Our experts offer you advice and assistance should you have any queries. You can contact us **24/7**.

Service Germany Our technology-oriented Competence Center in Lohr, Germany, is responsible for all your service-related queries for electric drive and controls.

Contact the **Service Hotline** and **Service Helpdesk** under:

Phone: **+49 9352 40 5060**
Fax: **+49 9352 18 4941**
E-mail: service.svc@boschrexroth.de
Internet: <http://www.boschrexroth.com>

Additional information on service, repair (e.g. delivery addresses) and training can be found on our internet sites.

Service worldwide Outside Germany, please contact your local service office first. For hotline numbers, refer to the sales office addresses on the internet.

Preparing information To be able to help you more quickly and efficiently, please have the following information ready:

- Detailed description of malfunction and circumstances
- Type plate specifications of the affected products, in particular type codes and serial numbers
- Your contact data (phone and fax number as well as your e-mail address)

Index

A

Accumulators.....	267
Alignment.....	121
Ambient temperature.....	203
Ambient temperature during operation.....	24
Attachments.....	220
Average speed.....	214
Axial load.....	214

B

Balancing.....	121, 212
Batteries.....	267
Bearing	
Wear.....	219
Bearing failure.....	219
Bearing lifetime.....	219
Bearing load.....	214
Bevel pinion.....	220
Braking energy.....	221

C

CE.....	224
Centering hole.....	121
Cleaning.....	227
Climatic environmental conditions	204
Compatibility.....	210
Concentricity.....	121
Conditions of installation.....	208
Connection cables	262
Connection diagram terminal box individual wiring.....	256
Connection technique	
Inner diameter.....	201
Operating pressure.....	227, 233
Connection technique MSK133 (terminal box).....	254
Connection time.....	24
Contained substances	
see "Significant components".....	267
Continuous current at standstill.....	23
Continuous torque at standstill.....	23
Coolant	
Corrosion protection.....	230
Coolant additives	
Ready-to-use cooling water.....	232
Water treatment kits.....	232
Coolant duct.....	227
Cooling connection.....	201
Cooling fins.....	261
Couplings.....	220

D

Design.....	208
Dimensions	
MSK133 (liquid cooling).....	157

Disconnection time.....	24
Disposal.....	267
Drag chains.....	262
Drive system.....	13

E

EAC.....	224
Electric drive system.....	13
Energy management chains.....	262
Environmental protection.....	267

F

Fan	
Minimum distance.....	226
Fixing screws.....	249
Flange.....	121
Flange attachment.....	249
Foot attachment.....	249
Foreign materials.....	210
Frame length.....	159
Frame size.....	159

H

Hazardous substances.....	267
Heat dissipation.....	261
Heat loss	
Heat loss dissipation.....	228
Utilization rate.....	228
Helical gearing.....	220
Helpdesk.....	273
Holding brake.....	160
Commissioning.....	223
electrically releasing.....	221
Warning.....	221
Holding brakes.....	221
Holding torque.....	24
Hotline.....	273
Housing varnish.....	121
Humidity	
absolute air humidity.....	204
relative air humidity	204

I

Identification.....	242
Inappropriate use	
Consequences, exclusion of liability.....	11
IndraSize.....	26
Installation altitude.....	203
Installation positions.....	208
Insulation class according to DIN EN 60034-1... ..	24
Intended use.....	11
IP protection type.....	207

K

Key.....	212
----------	-----

Index

L

Leakage capacitance.....	24
Liquid cooling	
Connection.....	201
Loop lifting straps.....	245

M

Machine accuracy.....	23
Mass.....	24
Maximum current.....	24
Maximum speed.....	24
Maximum torque.....	24
Minimum distance	
Motor.....	226
Moment of inertia of the brake.....	24
Moment of inertia of the rotor.....	24
Motor attachment.....	249
Motor cooling	
Coolant temperature.....	233
Coolants.....	230
Motor frame size.....	121
Motor mounting.....	250
Motor paint	
Additional paint.....	211
Motor type plate.....	243
Motor variants available.....	159
Mounting screws.....	249
MSK030B.....	30
MSK030C.....	31
MSK040B.....	32
MSK040C.....	34
MSK043C.....	36
MSK050B.....	38
MSK050C.....	40
MSK060B.....	42
MSK060C.....	44
MSK061B.....	46
MSK061C.....	47
MSK070C.....	50
MSK070D.....	53
MSK071C.....	59
MSK071D.....	62
MSK071E.....	65
MSK076C.....	77
MSK100A.....	79
MSK100B.....	82
MSK100C.....	85
MSK100D.....	88
MSK101C.....	91
MSK101D.....	94
MSK101E.....	97
MSK103.....	100, 101, 102
MSK131B.....	103
MSK131D.....	105
MSK133B-SA.....	107
MSK133C.....	110
MSK133D.....	113

MSK133E.....	117
--------------	-----

N

Non-intended use.....	12
Number of pole pairs.....	24

O

Operating hours.....	219
Output shaft.....	121, 212
Key balancing.....	160
Plain output shaft.....	212
Over-determined arrangement.....	220

P

Packaging.....	267
PELV.....	17
Pinion.....	220
Pressure drop.....	227
Processing cycle.....	215
Product.....	159
Production processes.....	267
Protection class acc. to EN 60529.....	24
Protection type.....	207
Protective extra-low voltage.....	17

R

Radial forces.....	208
Radial load.....	214
Radial shaft sealing ring.....	23, 212
Rated current.....	24
Rated voltage.....	24
Recycling.....	267
Return of products.....	267
RoHS	
China RoHS 2.....	225
RoHS II.....	224
Run-out.....	121
Running noises.....	262

S

Safety notes for electric drives and controls.....	13
Sealing air.....	188
Service hotline.....	273
Shaft	
plain.....	212
with keyway.....	212
Shaft end.....	121
Shaft load.....	214
Shaft sealing ring.....	212
Shock.....	206
Shock absorbers.....	245
Shutdown temperature.....	234
Significant components.....	267
sine-wave oscillations.....	205
Sound pressure level.....	24
Standards.....	9
state of the art.....	11

Storage time.....	239
Strength.....	250
Support.....	273

T

temperature increase on the housing 60K.....	23
temperature increase on the motor winding 100K.....	23
Temperature sensor.....	234
Thermal time constant.....	24
Tightness.....	213
Torque constant at 20 °C.....	24
Transmissions	220
Twisting moment	197

U

UL approval.....	224
Use	
Inappropriate use.....	12
Intended use.....	11

V

Vibration.....	205
Vibration severity grade (quality of vibration)....	121
Voltage constant at 20 °C.....	24

W

Warning temperature.....	234
Winding.....	159
Winding inductivity.....	24
Winding resistance at 20 °C.....	24
Wiring diagram.....	192

Notes

Notes

Bosch Rexroth AG

Electric Drives and Controls

P.O. Box 13 57

97803 Lohr, Germany

Bgm.-Dr.-Nebel-Str. 2

97816 Lohr, Germany

Phone +49 9352 18 0

Fax +49 9352 18 8400

www.boschrexroth.com/electrics



R911296289