



CMM-EC02/CMM-EC03

EtherCAT Communication Card Operation Manual



Applicable Products:
CMM-EC02, CMM-EC03 (MS300 / MH300 Option Card)

Application

Drive Firmware Version: MS300 V1.07 / MH300 V1.02 or later
CMM-EC02 Communication Card Firmware Version: V1.01 or later
CMM-EC03 Communication Card Firmware Version: V2.04 or later



<http://www.deltaww.com/>

Copyright notice

©Delta Electronics, Inc. All rights reserved.

All information contained in this user manual is the exclusive property of Delta Electronics Inc. (hereinafter referred to as "Delta ") and is protected by copyright law and all other laws. Delta retains the exclusive rights of this user manual in accordance with the copyright law and all other laws. No parts in this manual may be reproduced, transmitted, transcribed, translated or used in any other ways without the prior consent of Delta.

Limitation of Liability

The contents of this user manual are only for the use of the products manufactured by Delta. Except as defined in special mandatory laws, Delta provides this user manual "as is" and does not offer any kind of warranty through this user manual for using the product, either express or implied, including but not limited to the following: (i) this product will meet your needs or expectations; (ii) the information contained in the product is current and correct; (iii) the product does not infringe any rights of any other person. You shall bear your own risk to use this product.

In no event shall Delta, its subsidiaries, affiliates, managers, employees, agents, partners and licensors be liable for any direct, indirect, incidental, special, derivative or consequential damages (including but not limited to the damages for loss of profits, goodwill, use or other intangible losses) unless the laws contain special mandatory provisions to the contrary.

Delta reserves the right to make changes to the user manual and the products described in the user manual without prior notice and afterwards.



Caution

This operation manual provides information on specifications, installation instructions, basic operations/configurations, and details on network communication protocols.

- ✓ The AC motor drive is a sophisticated electronic device. For the safety of the operator and your mechanical equipment, only qualified electrical engineers are allowed to perform the installation/trial runs and make parameter adjustments. If you have any question or concern, please contact your local Delta distributor. Our professional staff will be very glad to help you.
- ✓ Please read this manual carefully and follow the instructions completely to avoid device damage or personal injury.

Table of Contents

1. Introduction	6
1.1 Network Functions and Specifications.....	6
1.2 Product Appearance.....	7
1.2.1 Panel Cut Out Dimensions.....	7
1.2.2 Components	7
1.3 LED Indicators	8
1.4 RJ45 PIN Definition.....	8
1.5 Application	8
1.5.1 Applicable firmware version and supporting mode.....	8
2. Installation and Wiring	9
2.1 Mounting Position of Communication Card	9
2.2 Install and Remove Option Cards	10
2.2.1 Communication Cable and Grounding.....	10
□ Communication Cable.....	10
□ Grounding.....	11
2.2.2 MS300 Installation	13
MS300 Mounting Position 1 (See Section 2.1 for Details on Mounting Position) Frame A-F13	
2.2.3 MH300 Installation	13
MH300 Mounting Position 1 (See Section 2.1 for Details) – Frame A – I.....	13
2.3 Network Connection	17
2.4 MH300 / MS300 Drive Settings.....	17
2.5 ESI (EtherCAT Slave Information).....	17
3. Introduction to EtherCAT	18
3.1 Protocol	18
3.2 EtherCAT State Machine.....	19
3.3 Dynamic Recognition	20
4. System Setup	21
4.1 Asynchronous.....	21
4.2 PDO mapping configuration	22
4.2.1 Default PDO mapping configuration.....	22
4.2.2 Set PDO mapping	23
5. CiA402 equipment regulation	24
5.1 CANopen over Ethernet (CoE) State Machine	24
5.2 EtherCAT Operation Mode	26
5.2.1 Velocity Mode.....	26
6. Communication Warning / Fault Table	28
6.1 Motor drive warning / fault table	28
6.2 SDO Abort Code	29

7. Operation Example	30
7.1 Delta PLC-AX-8 Operation Example (Designer-AX (Codesys base)).....	30
7.2 Delta PLC – AH10EMC Operation Example (ECAT Builder).....	39
Appendix A	49
A.1 Description of Object Specification	49
A.1.1 Object Type	49
A.1.2 Data Type	49
A.2 Object Dictionary	50
A.2.1 OD 1000h Communication Group.....	50
A.2.2 OD 3000h Motor Drive’s Parameter Group	50
A.2.3 OD 6000h Communication Object Group	50
A.3 Detailed Information about Objects	51
A.3.1 OD 1000h Communication Group.....	51
A.3.2 OD 3000h Motor Drive’s Parameter Group	56
A.3.3 OD 6000h Communication Object Group	57

Issued Edition 02
Issued Date: August 2024

1. Introduction

1.1 Network Functions and Specifications

■ Ethernet Specifications

Item	Specifications
Interface	RJ45
Number of Ports	2 ports
Communication Mode	IEEE802.3, IEEE802.3u
Cable	Category 5e shielding 100 M
Transmission Speed	10 / 100 Mbps Auto-Defect
Communication Protocol	EtherCAT (NOTE)
Synchronization Mode	Free Run mode (asynchronous)
Communication Object	Process Data Object (PDO) Service Data Object (SDO) Emergency Object (EMCY)
Application Layer Specifications	CiA402 drive profile
Supported CiA402	Velocity Mode

NOTE: "EtherCAT® is a registered trademark and patented technology, licensed by Beckhoff Automation GmbH, Germany."

■ Environment Conditions

Item	Specifications
Noise Immunity	ESD (IEC 61800-5-1, IEC 6100-4-2) EFT (IEC 61800-5-1, IEC 6100-4-4) Surge Test (IEC 61800-5-1, IEC 6100-4-5) Conducted Susceptibility Test (IEC 61800-5-1, IEC 6100-4-6)
Operating Temperature	-10°C–50°C (temperature), 90% (humidity)
Storage Temperature	-25°C–70°C (temperature), 95% (humidity)
Vibration/Shock Resistance	International Standard IEC 61800-5-1, IEC 60068-2-6 / IEC 61800-5-1, IEC 60068-2-27

■ Electrical Specifications

Item	Specifications
Power Supply Voltage	15 V _{DC} (supplied by MH300 / MS300 drives)
Power Consumption	0.8 W
Insulation Voltage	500 V _{DC}
Weight (g; approx.)	27 (g)

1.2 Product Appearance

1.2.1 Panel Cut Out Dimensions

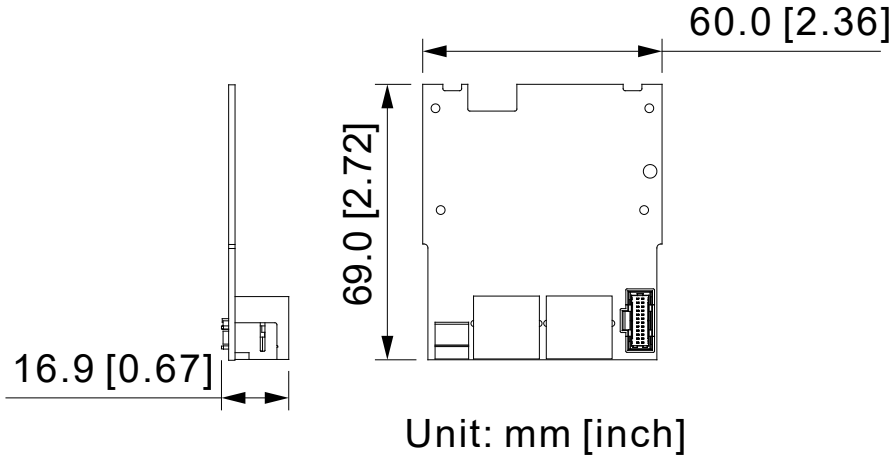

1.2.2 Components

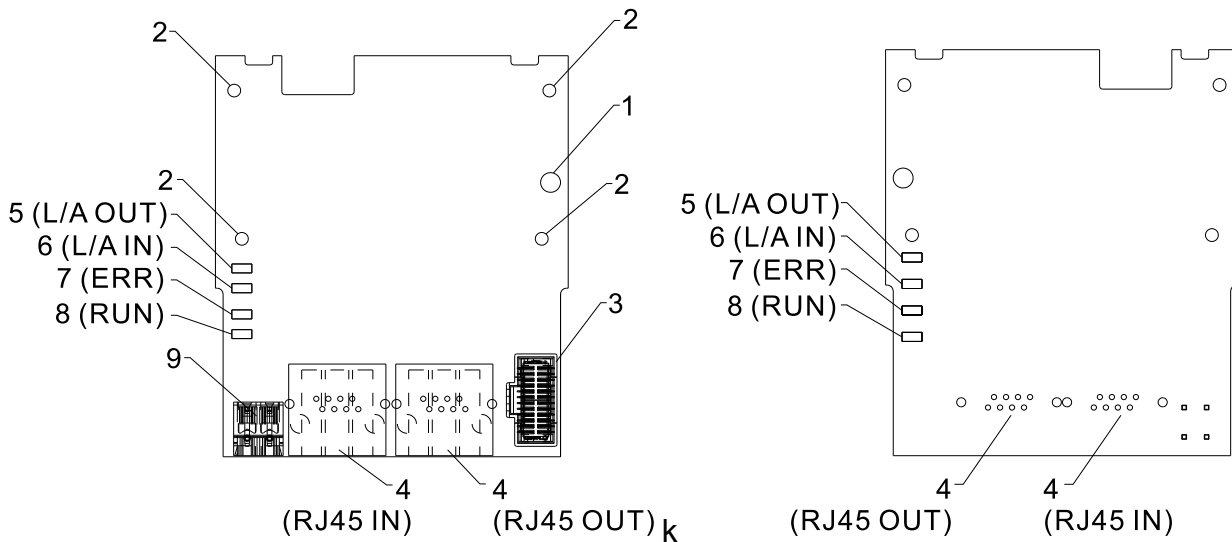

1. Screw fixing hole	5. L/A OUT (OUT LINK indicator)
2. Positioning hole for communication card	6. L/A IN (IN LINK indicator)
3. Control board connection port	7. ERR (ERR indicator)
4. RJ45 connection port	8. RUN (Communication card RUN indicator)
	9. Ground terminal block

1.3 LED Indicators

Name	Indicator Status		Indication
RUN	Green	On	Normal status
		Blink	Pre-operation (on / off 200 ms)
			Safe mode (on 200 ms / off 1000 ms)
Off	Initial status		
ERROR	Red	Blink	Basic configuration error (on / off 200 ms)
			Status switch error (on 200 ms / off 1000 ms)
			Time-out (on 200 ms twice / off 1000 ms)
Off	No error		
IN LINK	Green	On	Network connected
		Blink	Network in operation
		Off	Network not connected
OUT LINK	Green	On	Network connected
		Blink	Network in operation
		Off	Network not connected

1.4 RJ45 PIN Definition

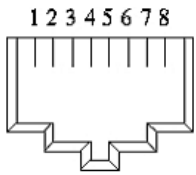
RJ45 Diagram	PIN #	Definition	Description
	1	Tx+	Positive pole for data transmission
	2	Tx-	Negative pole for data transmission
	3	Rx+	Positive pole for data reception
	4	--	N / C
	5	--	N / C
	6	Rx-	Negative pole for data reception
	7	--	N / C
	8	--	N / C

1.5 Application

1.5.1 Applicable firmware version

Applicable motor drive firmware version	MS300 V1.07 / MH300 V1.02 or later
Communication card firmware version	CMM-EC02 V1.01 or later/ CMM-EC03 V2.04 or later

NOTE: This user manual applies to MH300 and MS300 (hereafter referred to as “M300 series”).

2. Installation and Wiring

This section introduces how CMM-EC02/ CMM-EC03 connects to the M300 series and how CMM-EC02/ CMM-EC03 links to the internet.

2.1 Mounting Position of Communication Card

- MS300 Mounting Position of Communication Card

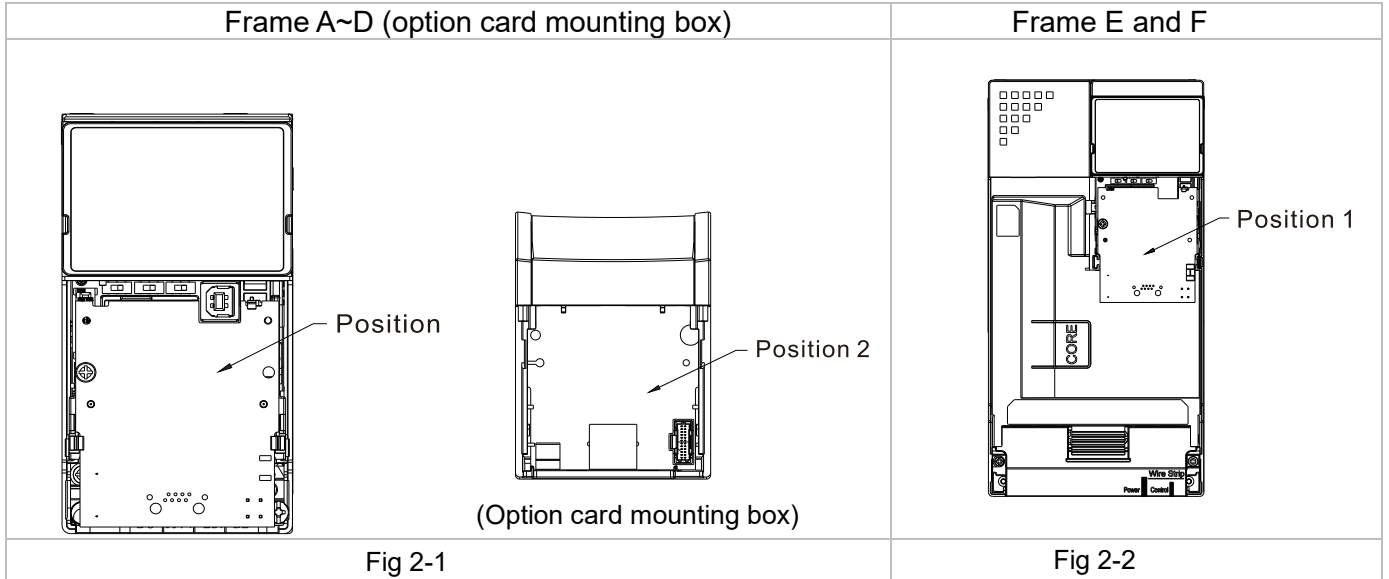

- MH300 Mounting Position of Communication Card

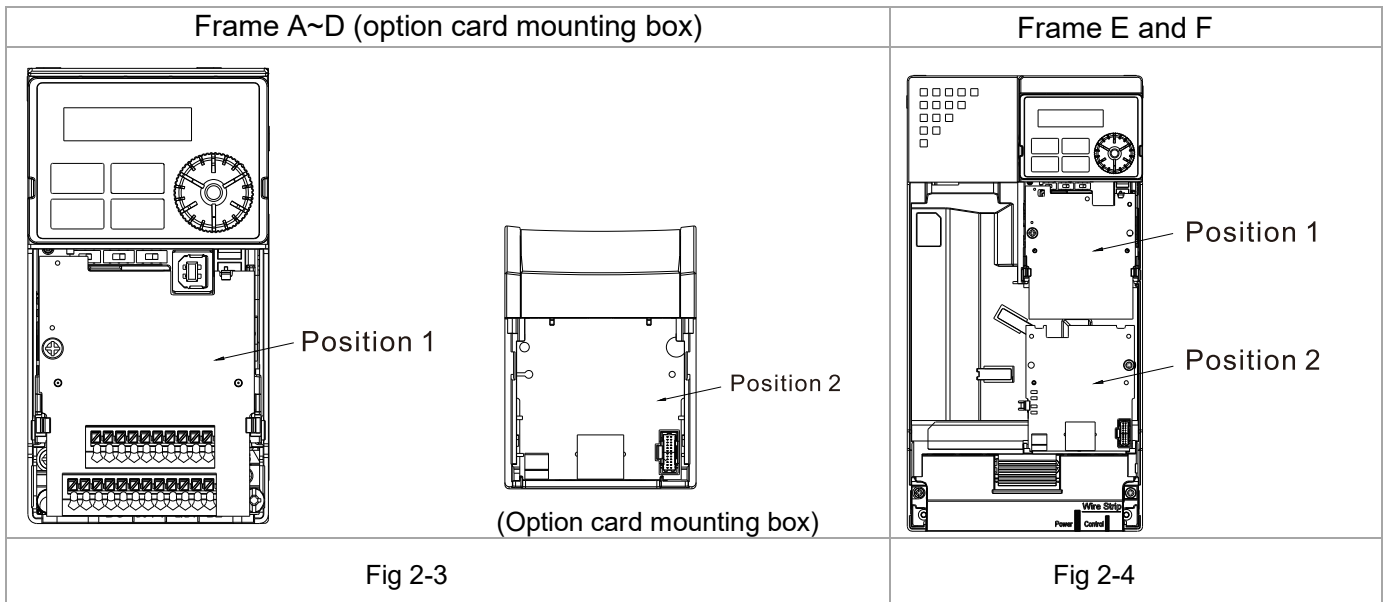

2.2 Install and Remove Option Cards

2.2.1 Communication Cable and Grounding

- Communication Cable

You have to order a communication card together with a communication cable, otherwise you won't be able to use the communication card. Verify the communication card model name and the mounting position to mount that communication card, then select the right communication cable. There are two kinds of communication cable, select the right cable in the table below according to the mounting position.

Communication card	CMM-EC02 / CMM-EC03 *	
	Mounting Position 1	Mounting Position 2
Frame	Communication cable	Communication cable
A	CBM-CL01A	CBM-CL01A
B		CBM-CL02A
C		
D		
E		
F		
G		
H		
I		
NOTE: CMM-EC02/ CMM-EC03 communication card is shipped with a mounting box. Order CBM-CL01A or CBM-CL02A together with CMM-EC02/ CMM-EC03 according to the mounting position.		

CBM-CL01A

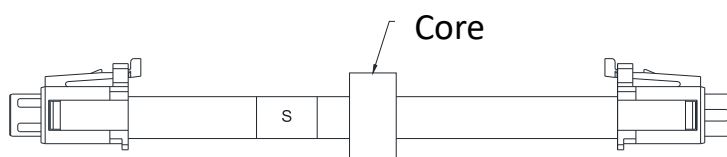

Fig 2-5

CBM-CL02A

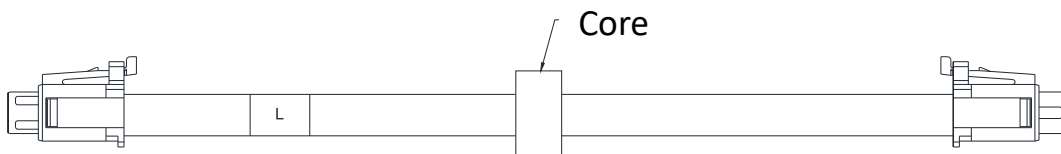

Fig 2-6

● Grounding

- You must ground the communication card when wiring CMM-EC02/ CMM-EC03. The ground terminal is included in the communication card package, as shown in Fig.2-7.
-

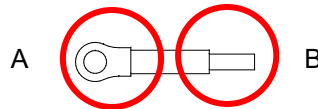

Fig 2-7

- Recommended wire size for grounding:
 - ☑ Wire gauge 16–20 AWG
 - ☑ Category 5 (Cat5 / Cat5e), Class D or above cable according to ISO/IEC 24702 (ISO/IEC 11801-3) and EIA/TIA 568-A-5
 - ☑ Maximum cable length 100 m
- Installation of the ground terminal:
 - ☑ When grounding, it is recommended to use grounding specifically for communication or clean grounding
 - ☑ The PE terminal for CMM-EC02/ CMM-EC03 includes PE1 and PE2. It is recommended to ground PE1 and PE2 at the same time and adjust according to actual situation.
 - ☑ PE1 (communication reference ground): connects to communication reference ground internally. Connecting PE1 to the ground reduces noise from those in application.
 - ☑ PE2 (RJ45 shielded layer): connects to RJ45 shielded layer internally. Connecting PE2 to the ground reduces noise from periphery.
 - ☑ Grounding example: If you cannot use grounding specifically for communication, you can ground the drive's PE to the equipment. The B end of the grounding wire connects to the ground terminal block of the communication card, as the circle shows in Fig.2-8. The A end of the grounding wire connects to the drive's PE, as the circles show in Fig.2-9, Fig.2-10, Fig.2-11 and Fig.2-12 by different frames for MS300/MH300.

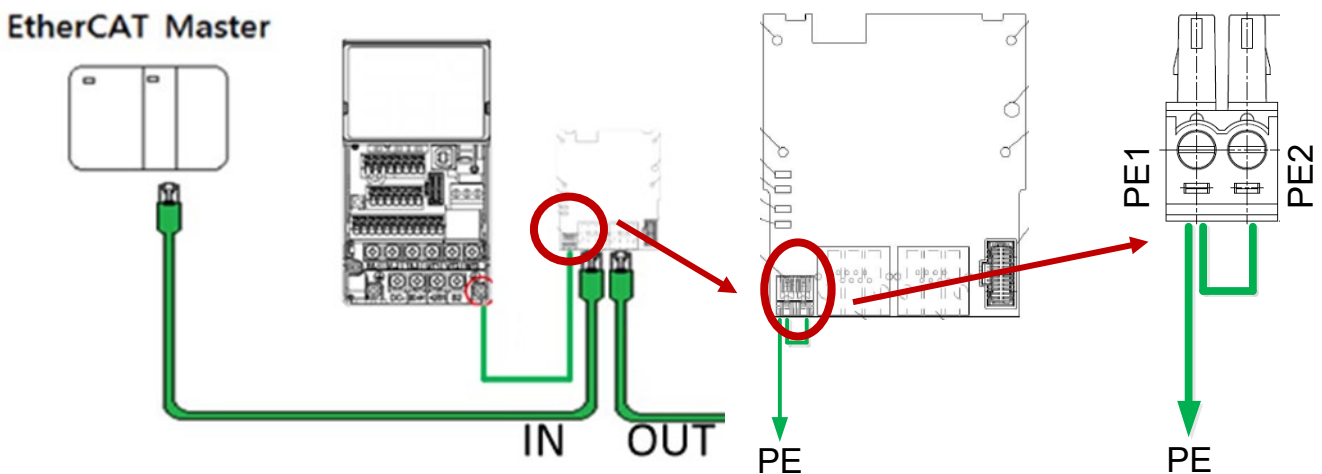

Fig 2-8

MS300 Frame A-C

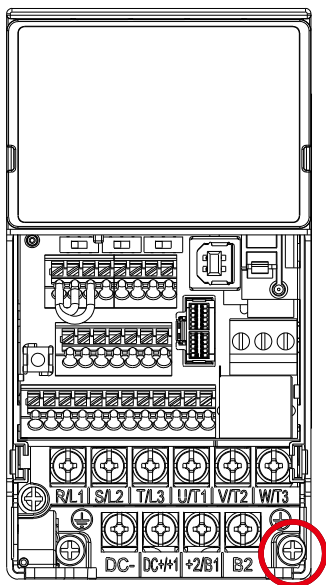

Fig 2-10

Torque ($\pm 10\%$)
 Frame A: 9 kg-cm [7.8 lb-in.] [0.88 Nm]
 Frame B: 15 kg-cm [13.0 lb-in.] [1.47 Nm]
 Frame C: 20 kg-cm [17.4 lb-in.] [1.96 Nm]

MS300 Frame D-F

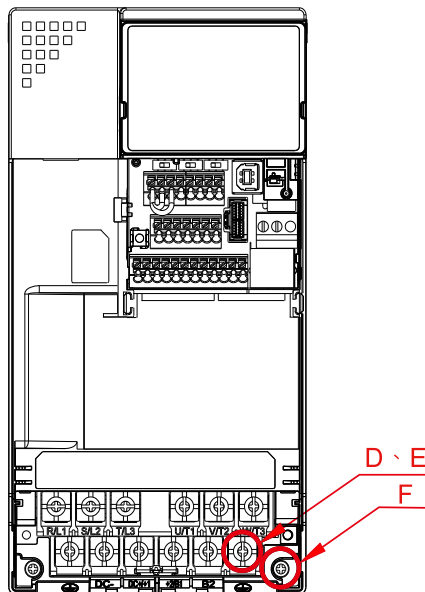

Fig 2-9

Torque ($\pm 10\%$)
 Frame D: 20 kg-cm [17.4 lb-in.] [1.96 Nm]
 Frame E: 25 kg-cm [21.7 lb-in.] [2.45 Nm]
 Frame F: 20 kg-cm [17.4 lb-in.] [1.96 Nm]

MH300 Frame A-C

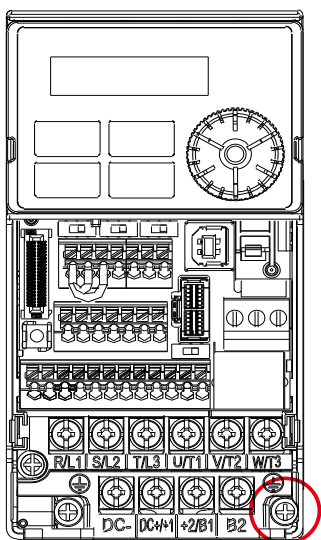

Fig 2-11

Torque ($\pm 10\%$)
 Frame A: 9 kg-cm [7.8 lb-in.] [0.88 Nm]
 Frame B: 15 kg-cm [13.0 lb-in.] [1.47 Nm]
 Frame C: 20 kg-cm [17.4 lb-in.] [1.96 Nm]

MH300 Frame D-F

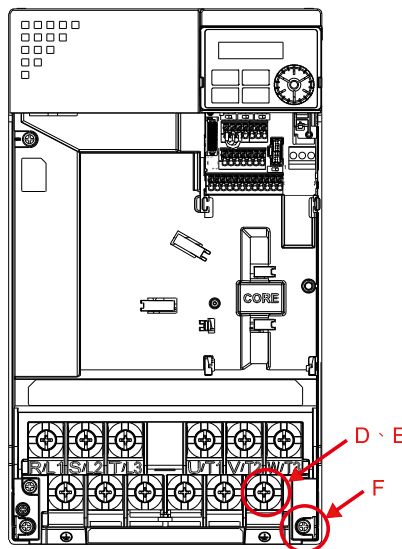

Fig 2-12

Torque ($\pm 10\%$)
 Frame D: 20 kg-cm [17.4 lb-in.] [1.96 Nm]
 Frame E: 25 kg-cm [21.7 lb-in.] [2.45 Nm]
 Frame F: 20 kg-cm [17.4 lb-in.] [1.96 Nm]

2.2.2 MS300 Installation

MS300 Mounting Position 1 (See Section 2.1 for Details on Mounting Position) Frame A-F

Installation method: Back-mount the communication card by connecting flat cables to the control board.

- Turn off the power of the motor drive, and then remove the front cover, as shown in Fig.2-13.
- Assemble the connection cable: Connect the connector at one end of the connection cable to the control board connector. Refer to Section 2.2.1 for more information on connection methods.
- Assemble the supported frame of the option card: Aim the two clips at the two slots on the motor drive, and then press downward to have the two clips engage the slots, as shown in Fig.2-14.
- Assemble the connection cable: Connect the connector at the other end of the connection cable to the connector of the communication card.
- Assemble the communication card: Have the terminal block and connector of the communication card face downward, aim the two holes of the communication card to the position column and press downward so that the three clips engage the communication card, as shown in Fig.2-15.
- Make sure that three clips properly engage the communication card and then tighten the screws (suggested torque value: 4–6 kg-cm [3.5–5.2 lb-in.] [0.39–0.59 Nm]), as shown in Fig.2-16.
- Assembly is completed, as shown in Fig.2-17.

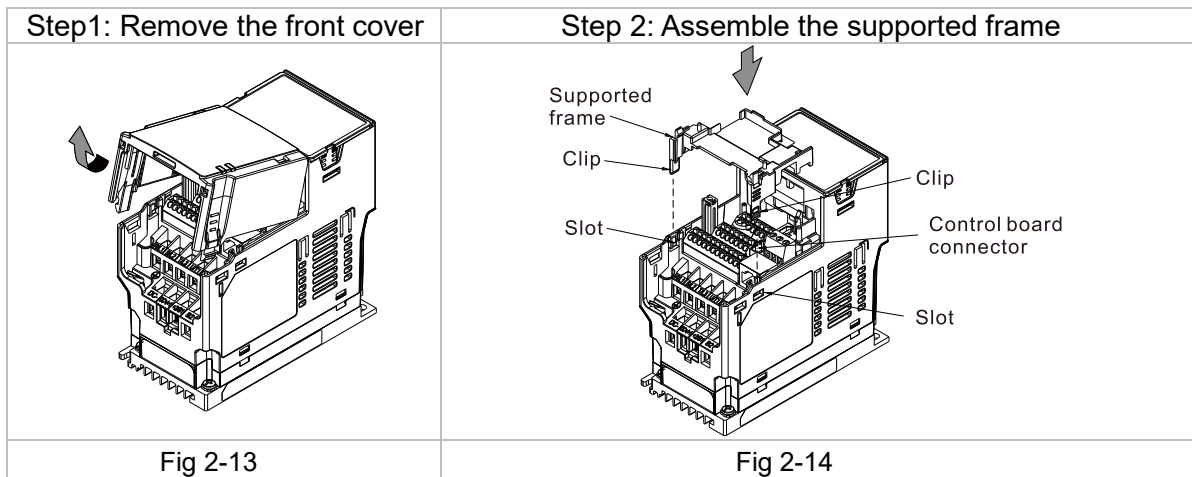

2.2.3 MH300 Installation

MH300 Mounting Position 1 (See Section 2.1 for Details) – Frame A – I

Installation method: **Back-mount** the communication card by connecting **flat cables** to the control board.

- Turn off the power of the motor drive, and then remove the front cover, as shown in Fig.2-24.
- Assemble the connection cable: Connect the connector at one end of the connection cable to the control board connector. Refer to Section 2.2.1 for more information on connection methods.
- Assemble the supported frame of the option card: Aim the two clips at the two slots on the motor drive, and then press downward to have the two clips engage the slots, as shown in Fig.2-25.
- Assemble the connection cable: Connect the connector at the other end of the connection cable to the connector of the communication card.
- Assemble the communication card: Have the terminal block and connector of the communication card face downward, aim the two holes of the communication card to the position column and press downward so that the three clips engage the communication card, as shown in Fig.2-26.
- Make sure that three clips properly engage the communication card, and then tighten the screws (suggested torque value: 4–6 kg-cm [3.5–5.2 lb-in.] [0.39–0.59 Nm]), as shown in Fig.2-27.
- Assembly is completed, as shown in Fig.2-28.

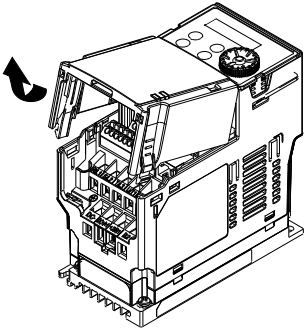
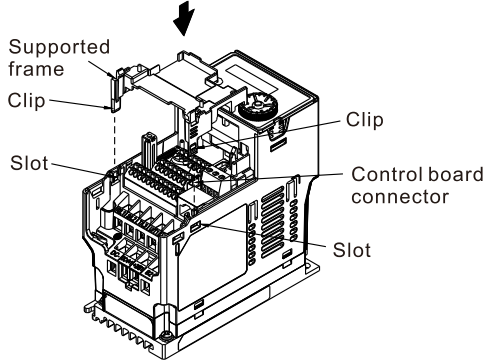
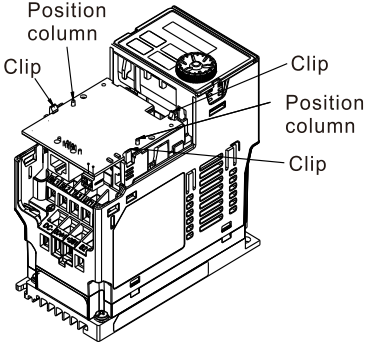
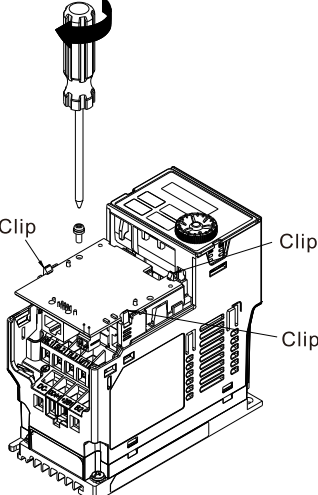
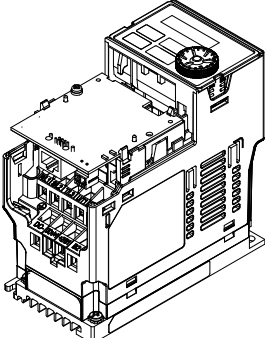
<p>Step1: Remove the front cover</p> 	<p>Step 2: Assemble the supported frame</p> 	
Fig 2-15	Fig 2-16	
<p>Step 3: Assemble the communication card</p> 	<p>Step 4: Tighten the screws</p> 	<p>Step 5: Assembly completed</p> 
Fig 2-17	Fig 2-18	Fig 2-19

2.2.4 MH300 Mounting Position 2 (See Section 2.1 for Details on Mounting Position) - Frame A–D

Installation method: **Front-mount** the communication card by connecting **flat cables** to the control board.

- Turn off the power of the motor drive, and then remove the front cover, as shown in Fig.2-29.
- Assemble the communication card: Detach the upper cover of the mounting box for the communication card by slipping and make the terminal block and connector of the communication card face upward. Fix the front end of the communication card to the slots, and then rotate it, as shown in the Fig.2-30.
- Make sure that two clips properly engage the communication card on the backside, and then tighten the screws (suggested torque value: 4–6 kg-cm [3.5–5.2 lb-in.] [0.39–0.59 Nm]), as shown in Fig.2-31.
- Assemble the clip connection cable: Connect the connector at one end of the connection cable to the control board connector. Refer to Section 2.2.1 for more information on connection methods.
- Attach the front cover of the drive.
- Assemble the connection cable: Connect the connector at the other end of the connection cable to the connector of the communication card.
- Attach the upper cover to the mounting box for the option card, as shown in Fig.2-32.
- Assemble the mounting box for the option card: Aim the four clips of the mounting box for the option card at the slots on the upper cover of the motor drive, and then press downward to have the four

clips engage the slots, as shown in the Fig.2-33.

- Assembly is completed, as shown in Fig.2-34.

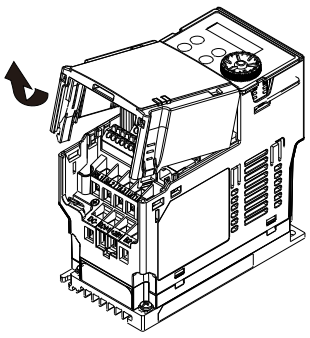
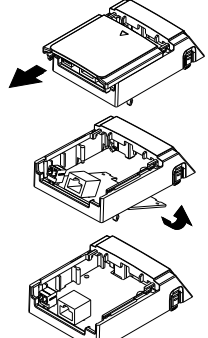
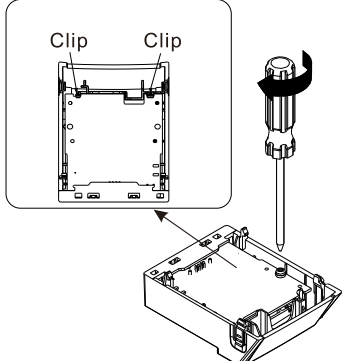
<p>Step 1: Remove the front cover</p> 	<p>Step 2: Assemble the communication card</p> 	<p>Step 3: Tighten the screws</p> 
<p>Fig 2-20</p>	<p>Fig 2-21</p>	<p>Fig 2-22</p>

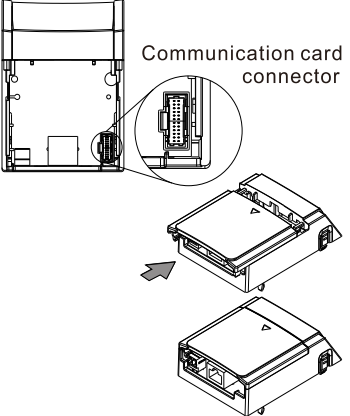
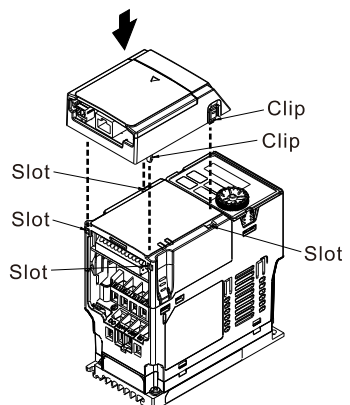
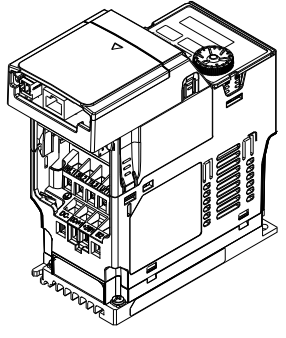
<p>Step 4: Attach the upper cover to the mounting box</p> 	<p>Step 5: Assemble the mounting box for the option card</p> 	<p>Step 6: Assembly completed</p> 
<p>Fig 2-23</p>	<p>Fig 2-24</p>	<p>Fig 2-25</p>

2.2.5 MH300 Mounting Position 2 (See Section 2.1 for Details on Mounting Position) - Frame E and F

Installation method: **Front-mount** the communication card by connecting **flat cables** to the control board.

- Turn off the power of the motor drive, and then remove the front cover, as shown in Fig.2-35.
- Assemble the connection cable: Connect the connector at one end of the connection cable to the control board connector. Refer to Section 2.1.1 for more information on connection methods. Wire the cables as Fig.2-36 shows and make sure the core is placed in the groove.
- Assemble the communication card: Have the terminal block and connector of the communication card face upward. Fix the front end of the communication card to the slots, and then rotate it, as shown in the Fig.2-37.
- Make sure that the clip properly engages the communication card, and then tighten the screws (suggested torque value: 4–6 kg-cm [3.5–5.2 lb-in.] [0.39–0.59 Nm]), as shown in Fig.2-38.
- Assemble the connection cable: Connect the connector at the other end of the connection cable to the connector of the communication card, as shown in Fig.2-39.
- Assembly is completed, as shown in Fig.2-40.

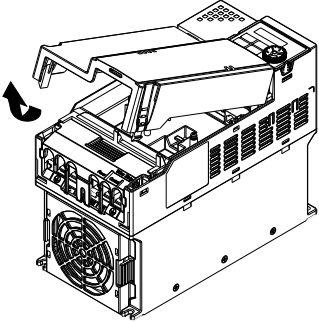
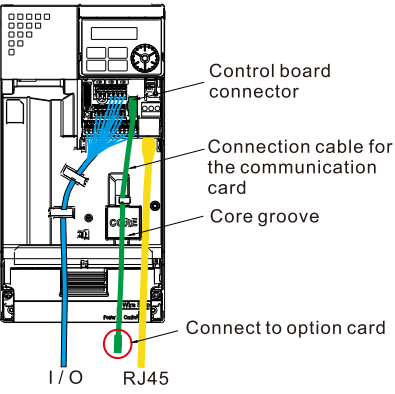
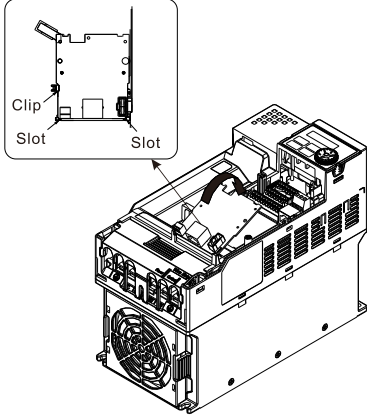
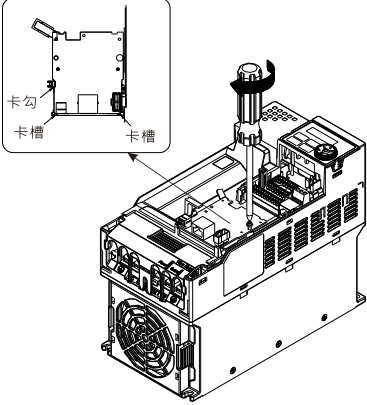
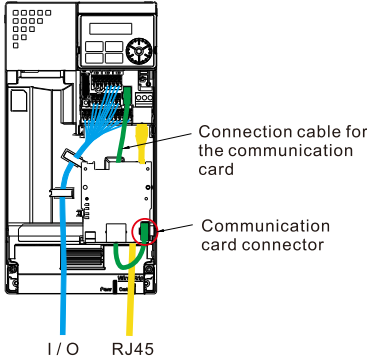
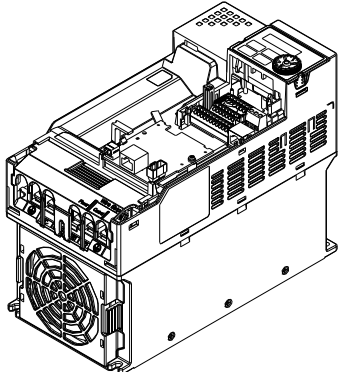
<p>Step 1: Remove the front cover</p> 	<p>Step 2: Assemble the connection cable</p> 	<p>Step 3: Assemble the communication card</p> 
<p>Fig 2-26</p>	<p>Fig 2-27</p>	<p>Fig 2-28</p>
<p>Step 4: Tighten the screws</p> 	<p>Step 5: Assemble the connection cable</p> 	<p>Step 6: Assembly completed</p> 
<p>Fig 2-29</p>	<p>Fig 2-30</p>	<p>Fig 2-31</p>

2.3 Network Connection

Pay attention to the connection method for EtherCAT because its packet delivery is directional. When front-mounting the communication card, the delivery direction for CMM-EC02/ CMM-EC03 is from left (IN) to right (OUT). The diagram below shows the correct wiring for front-mounting CMM-EC02/ CMM-EC03.

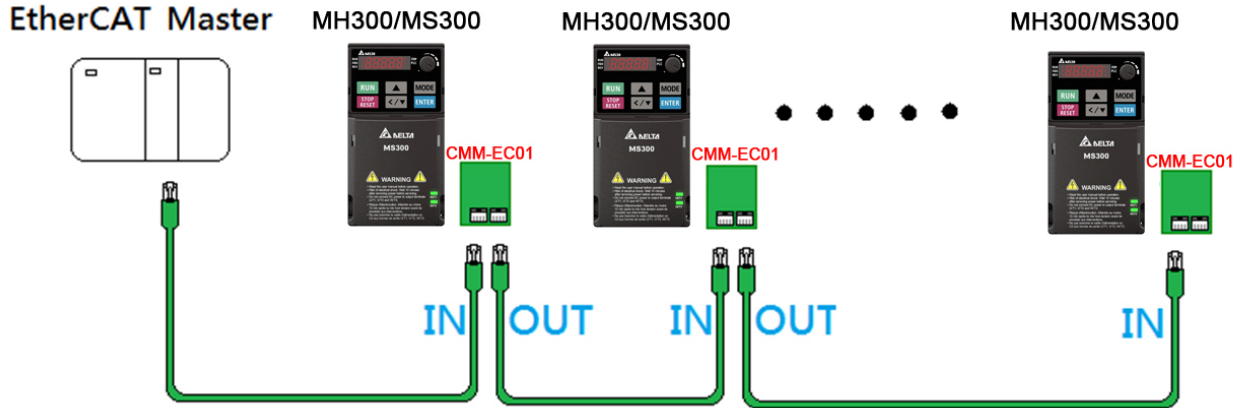

After finishing assembling the hardware, supply power to the drive. Then, Pr.09-60 on the drive should display “EtherCAT”, with a current value of 6. If not, make sure your version of the drive is correct and verify if the communication card is correctly connected.

2.4 MH300 / MS300 Drive Settings

When you operate MH300 / MS300 through CMM-EC02/ CMM-EC03, you must set the communication card as the source of controls and settings for MH300 / MS300. Use the keypad to configure the following parameter addresses to the corresponding values:

Keypad Pr.	Settings / Displayed Value	Function Description
Pr.00-20	8	Set communication card as the source of Frequency command.
Pr.00-21	5	Set communication card as the control source.
Pr.09-60	6	Communication card identification: When CMM-EC02/ CMM-EC03 communication card is connected, this parameter displays “6” (EtherCAT Slave).
Pr.09-30	1	Communication decoding method: EtherCAT only supports decoding method 2 (60xx).

2.5 ESI (EtherCAT Slave Information)

To make PLC or the host controller identify MH300 / MS300, you must load the product description file (ESI file). Download the description files from Delta’s download center.

http://www.deltaww.com/iadownload_acmotordrive.

The file name for M300 series:

MS300: DELTA_IA-MDS_MS300_CMM-EC01_Vx-xx_CMM-EC02_Vx-xx_Vx-xx_EC_EP_yymmdd.xml

MH300: DELTA_IA-MDS_MH300_CMM-EC01_Vx-xx_CMM-EC02_Vx-xx_Vx-xx_EC_EP_yymmdd.xml

NOTE:

1. Vx-xx is the firmware version for EtherCAT communication card.

2. yyyymmdd is the release year/month/date.

3. Introduction to EtherCAT

3.1 Protocol

EtherCAT (Ethernet for Control Automation Technology) was created by a German company Beckhoff based on the Ethernet communication protocol which is applicable on the industrial automation and industrial open, real-time, on-site fieldbus technology. The EtherCAT Technology Group (ETG) currently supports and promotes future development of this technology

The Ethernet structure of a motor drive is shown in the image below.

1. Communication layer: This protocol covers communication objects such as PDO, SDO, Sync and Emergency Objects. It also covers related communication object dictionary.
2. DS402 is the motion control layer (Drives and motion control device profile) It defines the action of different motions and the parameter setting of the objects when

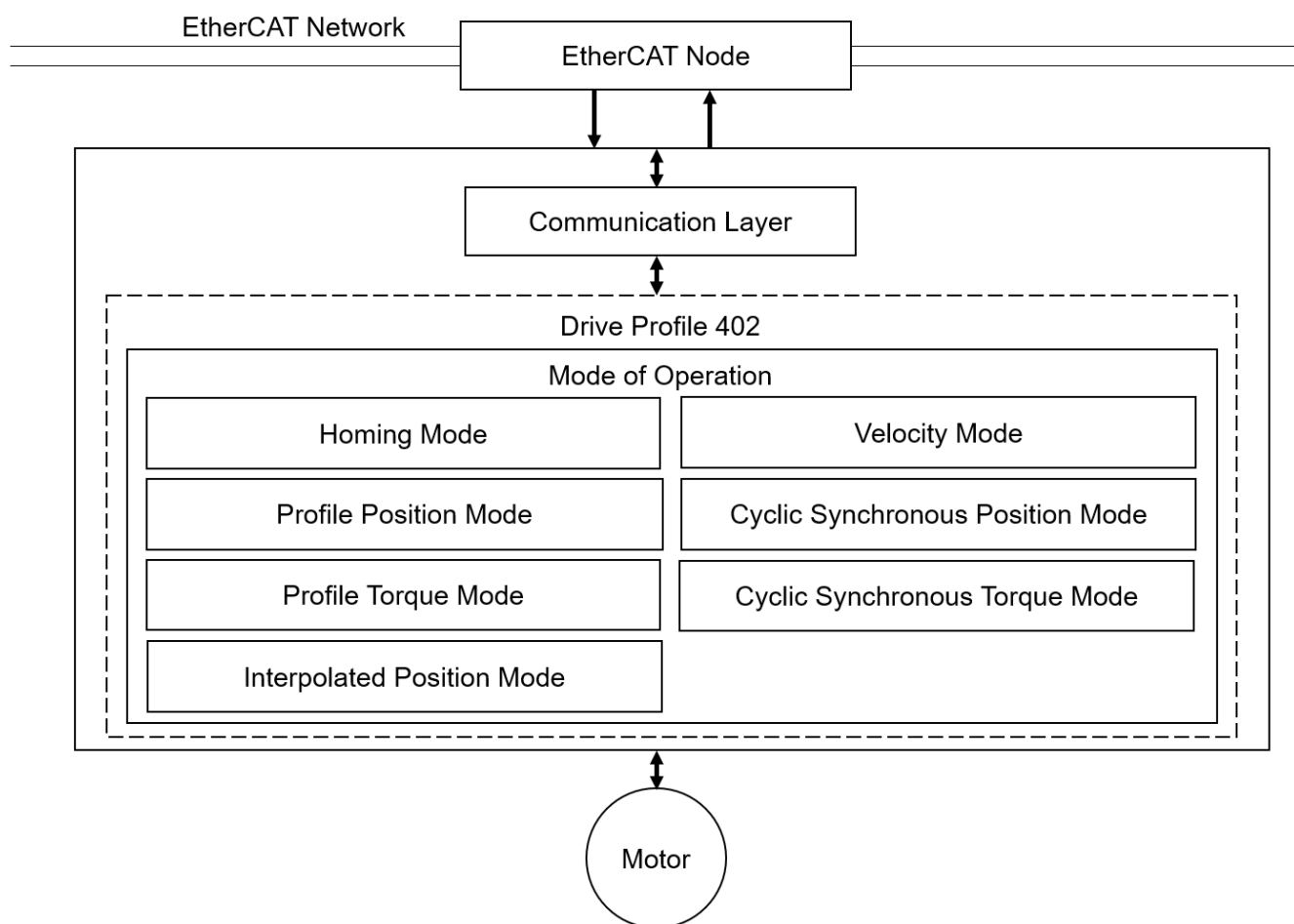

3.2 EtherCAT State Machine

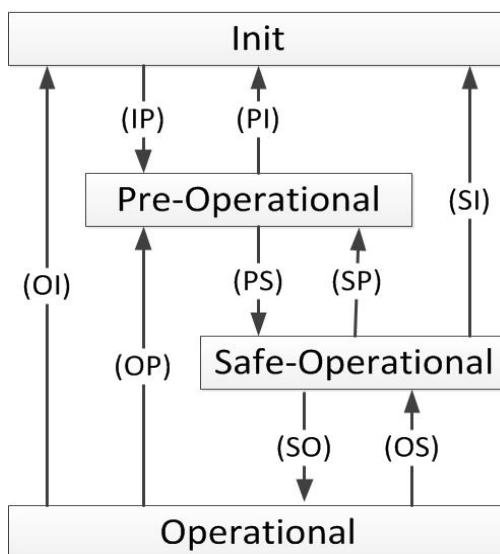

State Description:

State	Description
Init	The drive successfully finishes initializing after power-on, and no error occurs. There are no communications for the application layer.
Pre-Operational	Can use mailbox communication for the current status.
Safe-Operational	Can read PDO input data (TxPDO) Cannot receive PDO output data (RxPDO)
Operational	Executes cyclic I/O communications. Can process PDO output data (RxPDO).
'State Switch Command	Description
IP	Starts mailbox communication.
PI	Interrupts mailbox communication.
PS	Starts updating input data (TxPDO).
SP	Stops updating input data (TxPDO).
SO	Starts updating output data (RxPDO)
OS	Stops updating output data (RxPDO)
OP	Stops updating input/output data.
SI	Stops updating input data and mailbox communication.
OI	Stops all input/output data update and mailbox communication.

3.3 Dynamic Recognition

CMM-EC03 EtherCAT card can recognize the corresponding VFD model and dynamically modify the EEPROM product code.(MS300: 0x10400200, MH300: 0x104001F0).

CMM-EC02 EtherCAT card does not have the function to recognize the VFD model dynamically. The user needs to use a PC tool to burn ESI file manually to modify the corresponding product code.

CMM-EC02 EtherCAT card can burn ESI files with the following tools:

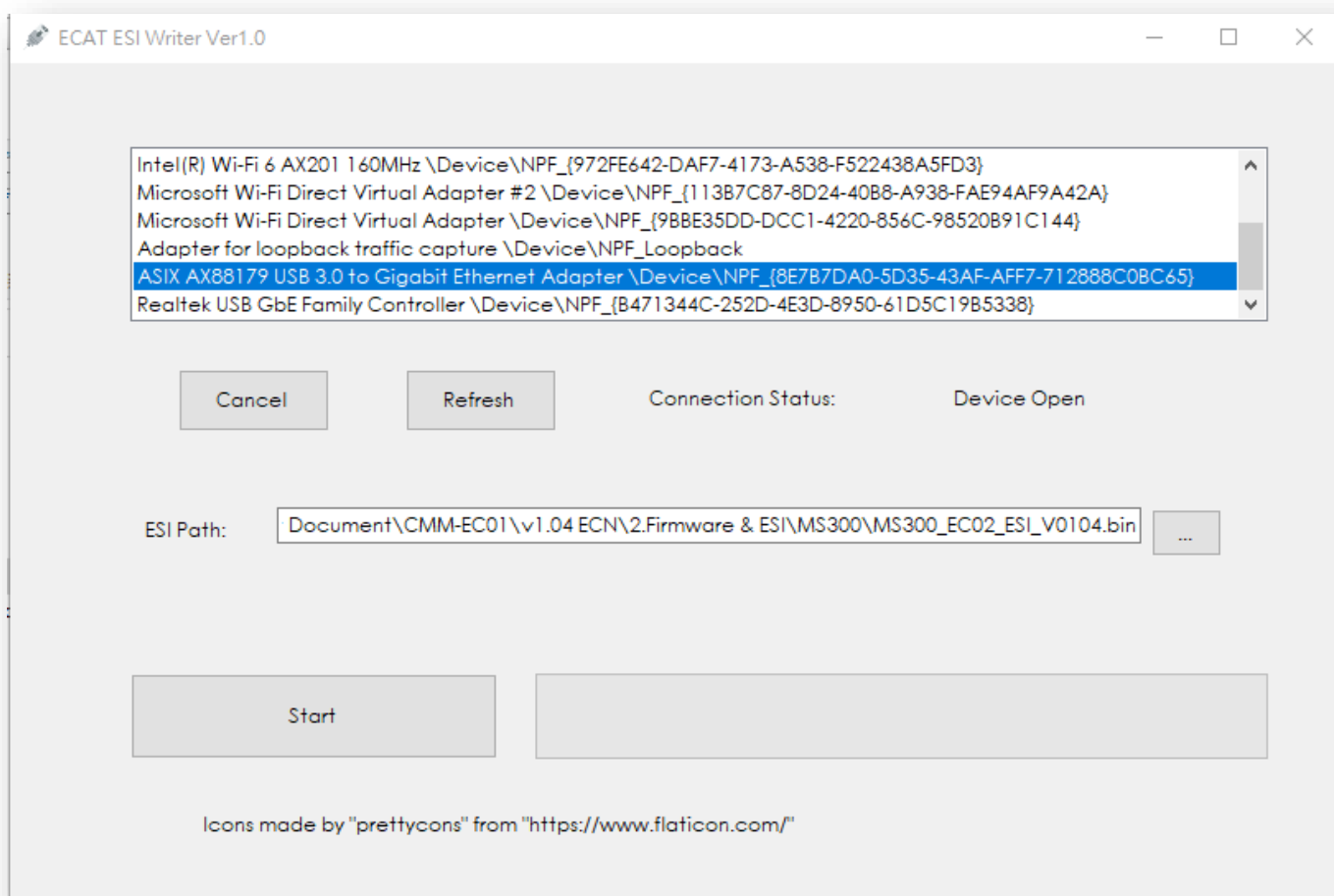

4. System Setup

4.1 Asynchronous

The motor drive currently supports only Free Run mode (Asynchronous)

Free Run Mode (Asynchronous)

The master and slave stations run asynchronously. Each station has an individual clock that calculates the time. In other words, the clocks of the master and slave are not synchronized. The command and feedback transmissions between the master and slave are based on a sequential order instead of a precise time synchronization. For example, the master sends a PDO at time T1, and the slave receives the PDO at T2 after the SM2 event.

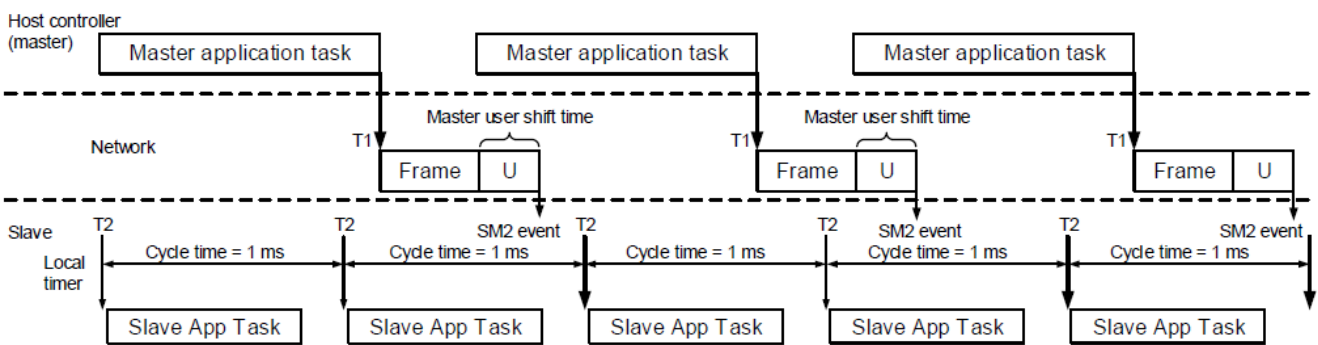

4.2 PDO mapping configuration

4.2.1 Default PDO mapping configuration

The following table shows the default PDO mapping configuration of the EtherCAT motor drive for data exchange. This is also defined in the XML file of the EtherCAT slave. You can modify the PDO mapping configuration according to the requirements.

RxPDO mapping

First group of RxPDO mapping in VL Mode

RxPDO (0x1600)	Controlword (0x6040)	vl target velocity (0x6042)	Mode of Operation (0x6060)
	Max Torque (0x6072)	Max Motor Speed (0x6080)	

TxPDO mapping

First group of TxPDO mapping

TxPDO (0x1A00)	Statusword (0x6041)	Mode of Operation Display (0x6061)	Position Actual Value (0x6064)
	Velocity Actual Value (0x606C)	Torque Actual Value (0x6077)	Error Code (0x603F)

4.2.2 Set PDO mapping

The settings are as follows:

1. Disable the PDO configuration: set OD 1C12 sub 0 to 0 (RxPDO) and OD 1C13 sub 0 to 0 (TxPDO).
2. Disable the PDO mapping setting: set OD 1600 sub 0 to 0 (RxPDO) and OD 1A01 sub 0 to 0 (TxPDO).
3. Set the contents and number of RxPDO mappings: set OD 1600 to 1603 sub 1 to sub 8 (RxPDO) for the content and set OD 1600 to 1603 sub 0 (RxPDO) for the number of RxPDO mappings. Take the OD 1601 as an example.

Mapping parameter setting for RxPDO	Data	Description
OD 1601 sub1	6040h	Controlword, 16-bit
OD 1601 sub2	6060h	Modes of operation, 8-bit
OD 1601 sub3	6072h	Max torque, 32-bit
OD 1601 sub4	607Ah	Target torque, 32-bit
OD 1601 sub5	6080h	Max motor speed, 32-bit
OD 1601 sub0	5	Set 5 for the number of RxPDO mappings

4. Set the contents and number of TxPDO mappings: set OD 1A00 to 1A03 sub 1 to sub 8 (TxPDO) for the content and set OD 1A00 to 1A03 sub 0 (TxPDO) for the number of TxPDO mappings. Take the OD 1A00 below as an example

Mapping parameter setting for RxPDO	Data	Description
OD 1A00 sub1	6041h	Statusword, 16-bit
OD 1A00 sub2	6061h	Modes of operation display, 8-bit
OD 1A00 sub3	6064h	Position actual value, 32-bit
OD 1A00 sub4	606Ch	Velocity actual value, 32-bit
OD 1A00 sub5	6077h	Max motor speed, 32-bit
OD 1A00 sub6	603Fh	Error code, 16-bit
OD 1A00 sub0	6	Set 6 for the number of RxPDO mappings.

5. Set the PDO mapping configuration: set OD 1C12 sub 1 to 0x1601 (RxPDO) and OD 1C13 sub 1 to 0x1A01 (TxPDO).
6. Enable the PDO configuration: set OD 1C12 sub 0 to 1 (RxPDO) and OD 1C13 sub 0 to 1 (TxPDO).

5. CiA402 equipment regulation

This section describes the modes of operation specified by CiA402 when the motor drive is in the EtherCAT mode. The contents include basic operation and setting of related objects. The host controller controls the motor drive through the control word (OD 6040h) and read the current status of the motor drive through the status word (OD 6041h). The motor drive follows the commands from the host controller to run the motors.

5.1 CANopen over Ethernet (CoE) State Machine

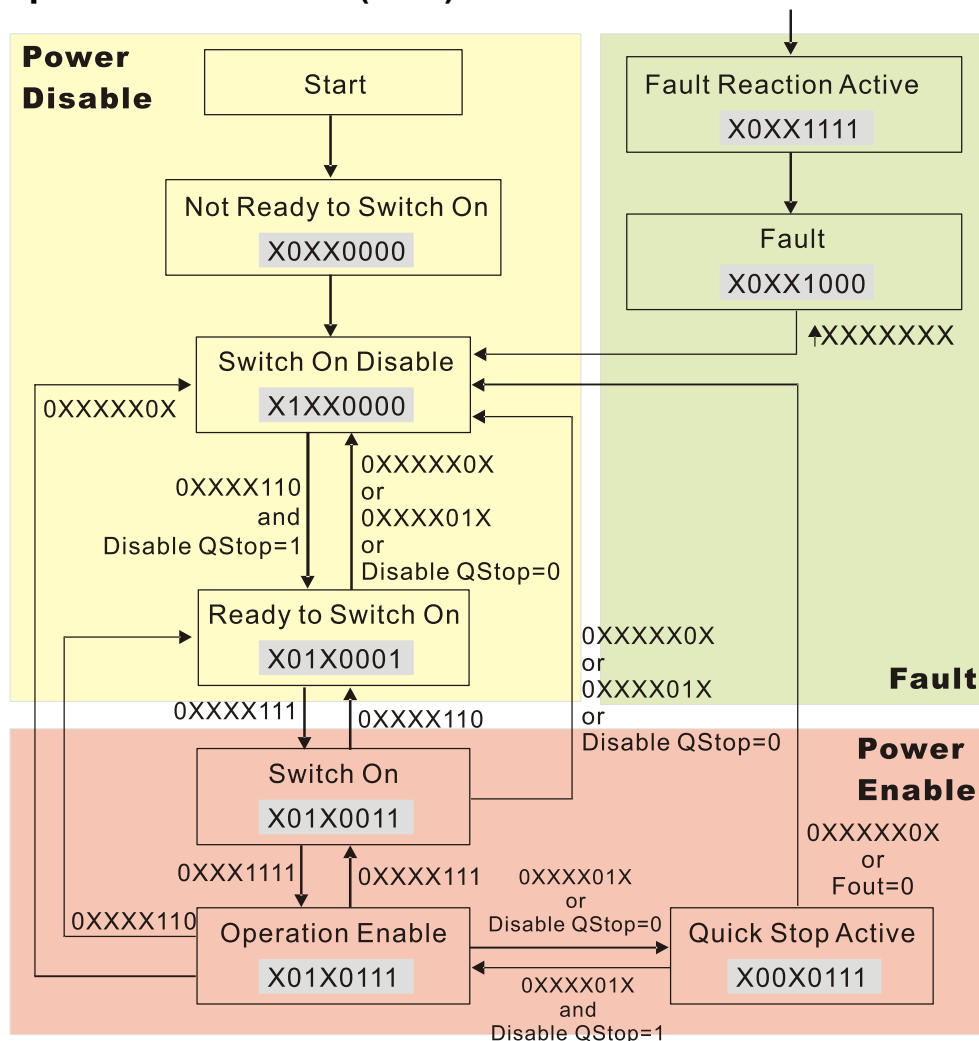

NOTE: As shown in the diagram above, the strings beside the arrows are the control words and the strings in the squares are the status words.

The state machine can be divided into three blocks.

Block	Description
Power Disable	Motor drive doesn't have PWM output.
Power Enable	Motor drive has PWM output.
Fault	Faults occur

The three big blocks are composed of 9 status

Status	Description
Start	Power-on
Not Ready to Switch On	The motor drive is initializing.
Switch On Disable	The motor drive finishes initializing.
Ready to Switch On	The motor drive is waiting to be switch on (energized). The motor isn't excited.
Switch On	The motor drive now has PWM output. The reference command is invalid.
Operation Enable	Motor is enabled, it runs by following control commands.
Quick Stop Active	Motor stops by following parameter setting.
Fault Reaction Active	The motor drive detects warning / fault and stops by following parameter settings. The motor is still excited.
Fault	The motor is not excited.

Control Word (controlword, OD 6040h): Description of Bit

15~9	8	7	6~4	3	2	1	0
Reserved	Halt	Fault reset	Operation mode specific	Enable operation	Quick stop	Enable voltage	Switch on

Status Word (statusword, OD 6041h): Description of Bit

15~14	13~12	11	10	9	8	7
Reserved	Operation mode specific	Reserved	Target reached	Remote	Reserved	Warning

6	5	4	3	2	1	0
Switch on disabled	Quick stop	Voltage enabled	Fault	Operation enable	Switch on	Ready to switch on

5.2 EtherCAT Operation Mode

5.2.1 Velocity Mode

The host controller sends velocity command and acceleration / deceleration data to a motor drive. Then the motor drive controls the velocity.

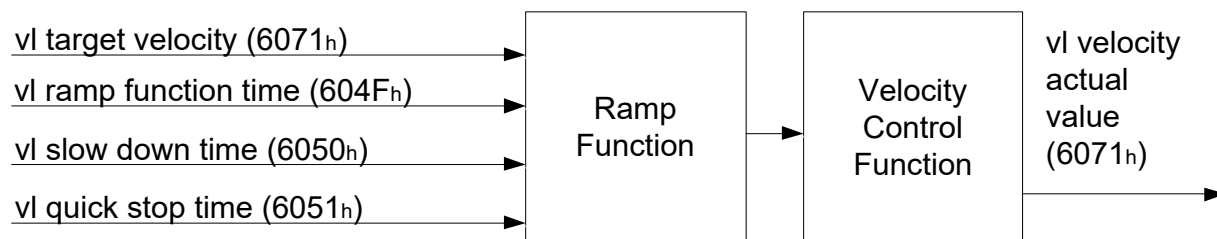

Operation Steps are as follows:

1. Set mode: OD 6060h = 02h as velocity mode
2. Set velocity command. OD 6042h (unit: RPM)
3. Set acceleration time OD 604Fh (unit: ms)
4. Set deceleration time OD 6050h (unit: ms)
5. Set control commands OD 6040h. By following the control word commands listed below to do the setup, the motor drive operates as mentioned above. Refer to the description of OP 6041h to see the contents of the state machine.
 - (1) OD 6040h = 06h, the motor drive goes into < Ready to Switch On > state.
 - (2) OD 6040h = 07h, the motor drive goes into < Switch On > Servo On state.
 - (3) OD 6040h = 0Fh, the motor drive goes into < Operation Enable > state.
 - (4) OD 6040h = 7Fh, the motor drive starts running.

Control commands are defined as follows:

Step	Bit 6	Bit 5	Bit 4	Bit 3	Bit 2	Bit 1	Bit 0	Description
(1)	0	0	0	0	1	1	0	Shutdown
(2)	0	0	0	0	1	1	1	Switch On (Enable Servo On ready)
(3)	0	0	0	1	1	1	1	Enable Operation (Enable Servo On)
(4)	1	1	1	1	1	1	1	Runs to the target speed.

When using the velocity mode (OD 6060h = 02h), the controlword bit (bit 4 ~ bit 6) is defined as follows:

OD 6040h			Description
bit 6	bit 5	bit 4	
1	0	1	Maintain current speed
1	1	1	Run to the target speed
X	X	X	Decelerate to 0 RPM

Read Motor Drive Data

- 1. OD 606Ch: to observe motor rotation speed
 OD 6041h: Motor drive's state word, bit 10 target reached (0: Not running to target speed; 1: Run to the target speed)

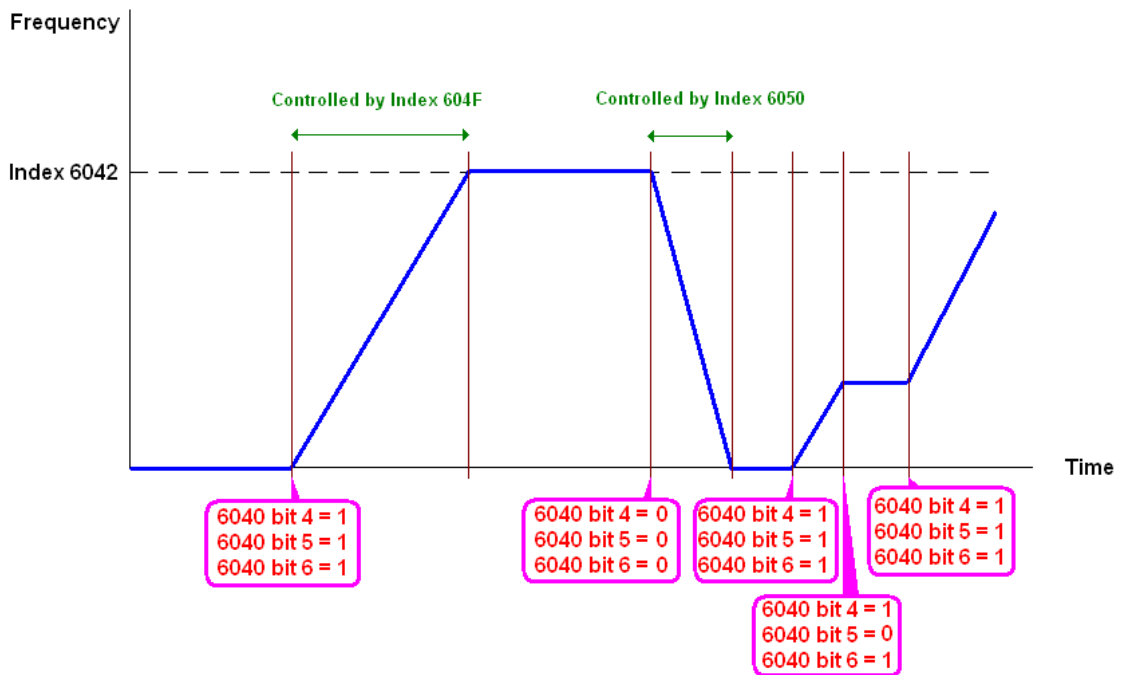

Index Related to the Motor Drive

Index	Definition	Form	Attribute
6040h	Controlword	UNSIGNED16	RW
6041h	Statusword	UNSIGNED16	RO
6060h	Mode of operation	INTEGER8	RW
6061h	Mode of operation display	INTEGER8	RO
6042h	vl target velocity	INTEGER16	RW
6043h	vl velocity demand	INTEGER16	RO
6044h	vl velocity actual value	INTEGER16	RO
604Fh	vl ramp function time	INTEGER16	RW
6050h	vl slow down time	INTEGER16	RW

6. Communication Warning / Fault Table

6.1 Motor drive warning / fault table

ID No.	Warning / Fault / Code	Warning / Fault Name	Description	Corrective Action
81	ECto_WARN	EtherCAT communication time out	Timer out warning on the Communication between communication card and the host controller.	-Verify if communication system is wiring correctly. -Verify if the upperhost is connecting correctly.
89	ECCb_WARN	Communication card disconnected	Warning on the disconnected communication card	-Reinstall the communication card. -Change a new communication card or change a new motor drive.
111	SYCE_WARN	Synchronization warning	The source of communication is not the communication card. Loss of synchronization signal (data packet) after setting up the synchronization mode. A warning message pops up.	-Reinstall a motor drive to the upperhost.
161	SYCE_ERR	Synchronization fault	The source of command is the communication card. Loss of synchronization signal (data packet) after setting up the synchronization mode. A fault message pops up.	Reinstall a motor drive to the upperhost.

6.2 SDO Abort Code

SDO Abort Code	Description
0x05030000	Deflection fault while doing segment transmission
0x05040000	SDO time out.
0x05040001	Client / servo command are invalid or don't exist.
0x05040005	Register overflow when running SDO.
0x06010000	Not supported access
0x06010001	Try to read a write-only object
0x06010002	Try to write a read-only object
0x06010003	Unable to write into sub-index. The sub-index has to be 0.
0x06020000	The object doesn't exist in the object dictionary.
0x06040041	Unable to map the object to PDO
0x06040042	The number and the length of the objects mapped to PDO is longer than PDO.
0x06040043	Format of the parameter is not compatible.
0x06040047	Compatibility issue of motor drive.
0x06060000	Fail to save due to hardware error. (Saving or returning to origin fault)
0x06070010	Incorrect data type; wrong parameter length.
0x06070012	Incorrect data type; parameter length is too long
0x06070013	Incorrect data type; parameter length is too short.
0x06090011	Sub-index doesn't exist.
0x06090030	The parameter value is out of bounds.
0x06090031	Setting value is too big.
0x06090032	Setting value is too small.
0x06090033	Detected Module Ident List (0xF030) and Configured Module Ident list (0xF050) don't match.
0x06090036	Setting value is smaller than the lower limit.
0x08000000	General error
0x08000020	Data cannot be read or written.
0x08000021	Data access denied due to local control.
0x08000022	Data access denied due to current status.
0x08000023	Object dictionary doesn't exist.

7. Operation Example

7.1 Delta PLC-AX-8 Operation Example (Designer-AX (Codesys base))

Equipment	AX-8	GLAN1 IP: 192.168.0.10
	Computer	Network card IP: 192.168.0.123
	Motor drive: M300 Communication card: CMM-EC02/ CMM-EC03	
Software	DIADesigner-AX	V1.1.0 and above

1. Connect CMM-EC02/ CMM-EC03 to AX-8 EtherCAT port. Then Connect the AX-8 to the Computer via Ethernet port (GLAN1)
2. Run DIADesigner-AX software, then click on **New Project**

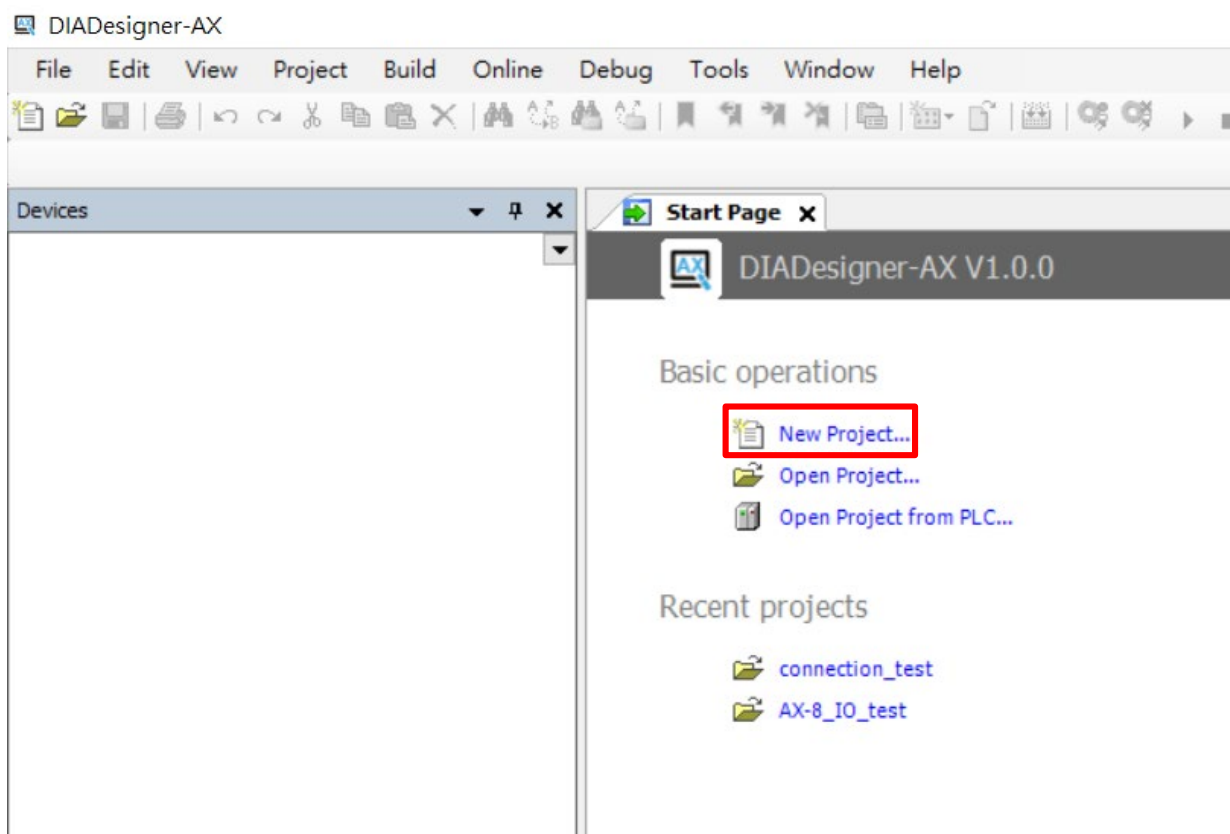

3. Select **Standard project** in the **New Project** window.

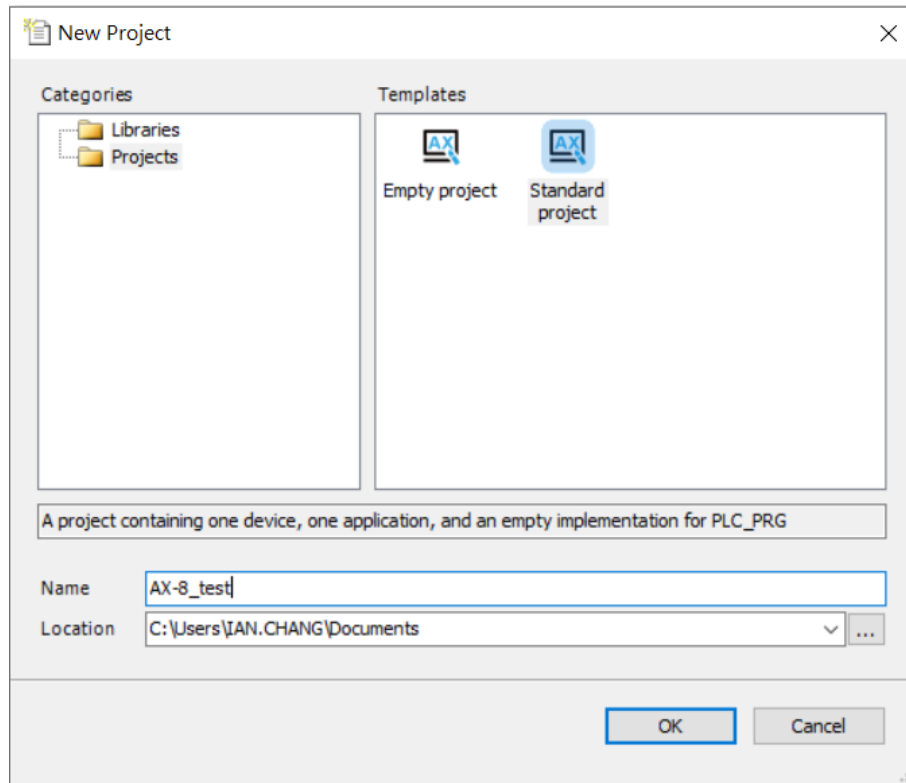

4. In the **Standard Project** window, choose the device **AX-8xxEP0 Windows Series, Version and PLC_PRG in**. Then click **OK** to create a new project.

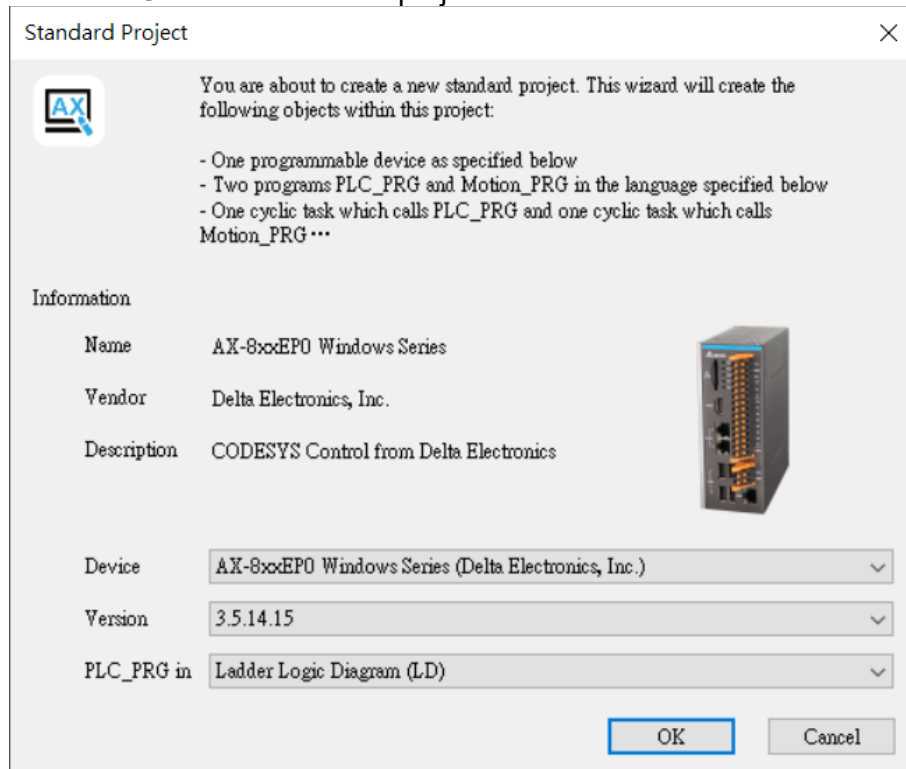

- After you create a new project, go to **Tools**→**Device Repository** to open a **Device Repository** window.

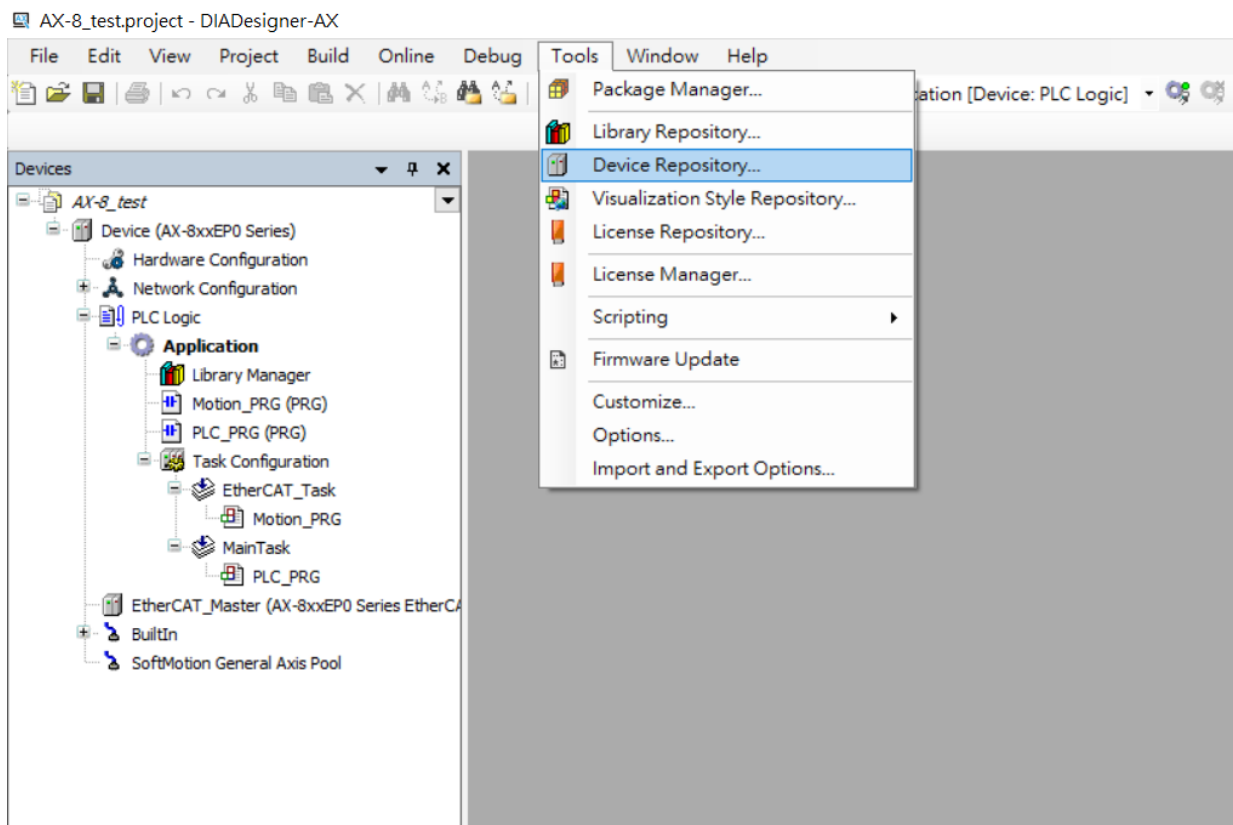

- After you open a **Device Repository** window, click **Install**.

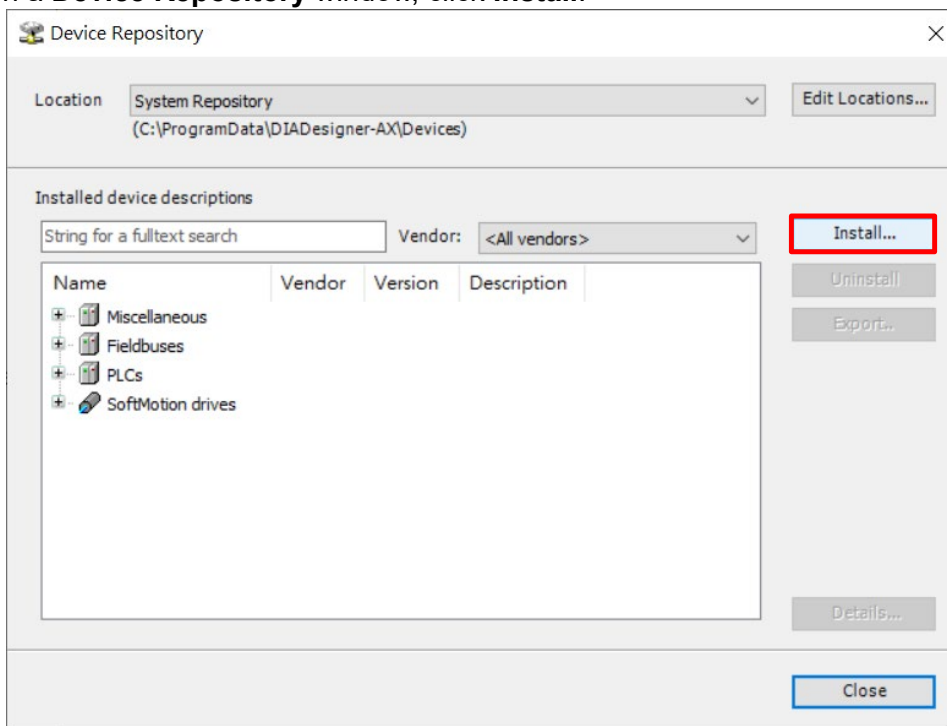

7. Import an ESI filer of MS300

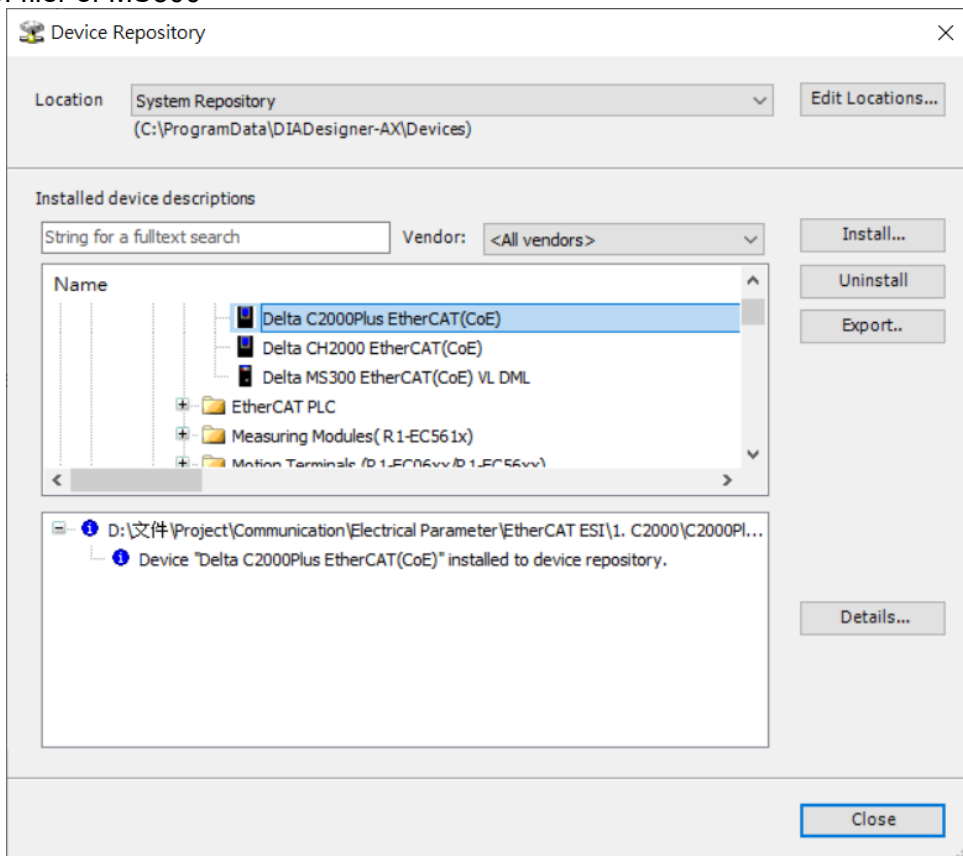

8. Double click on **Device (AX-8xxEP0 Series)**, then click **Scan Network**.

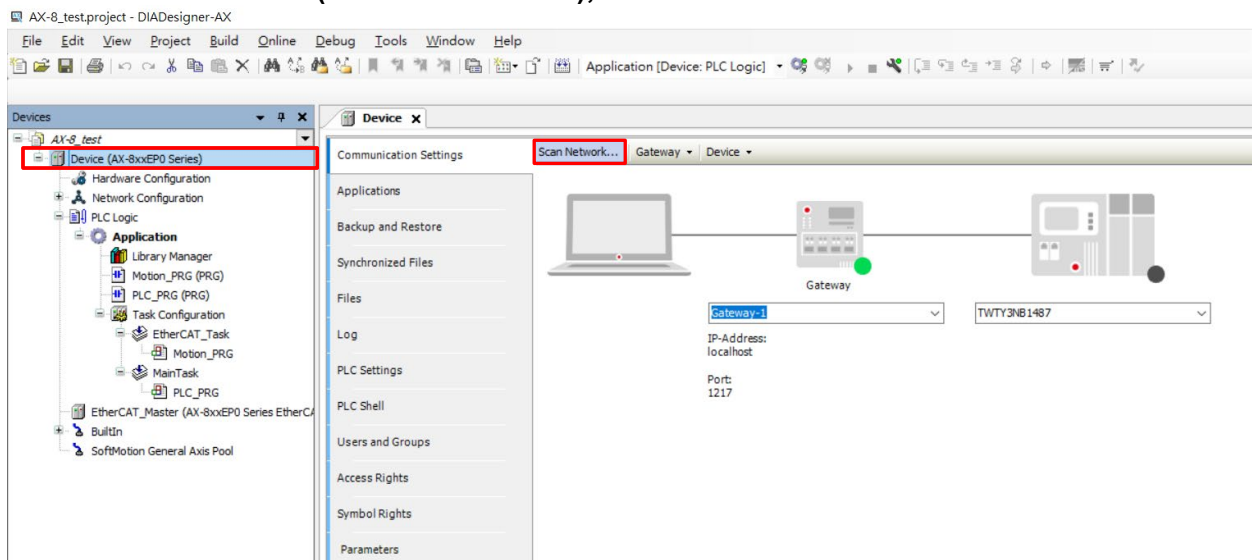

- If you connect the computer and the AX-8 correctly, you can see the AX-8's serial number. Click **OK**, you can see AX-8 hardware information.

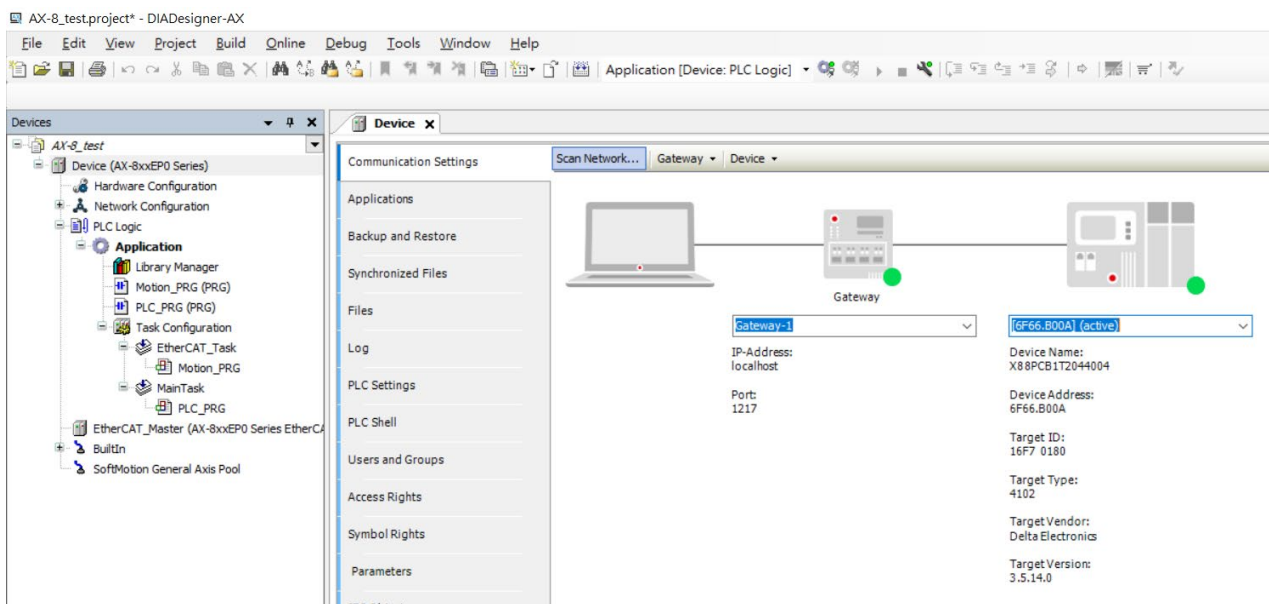
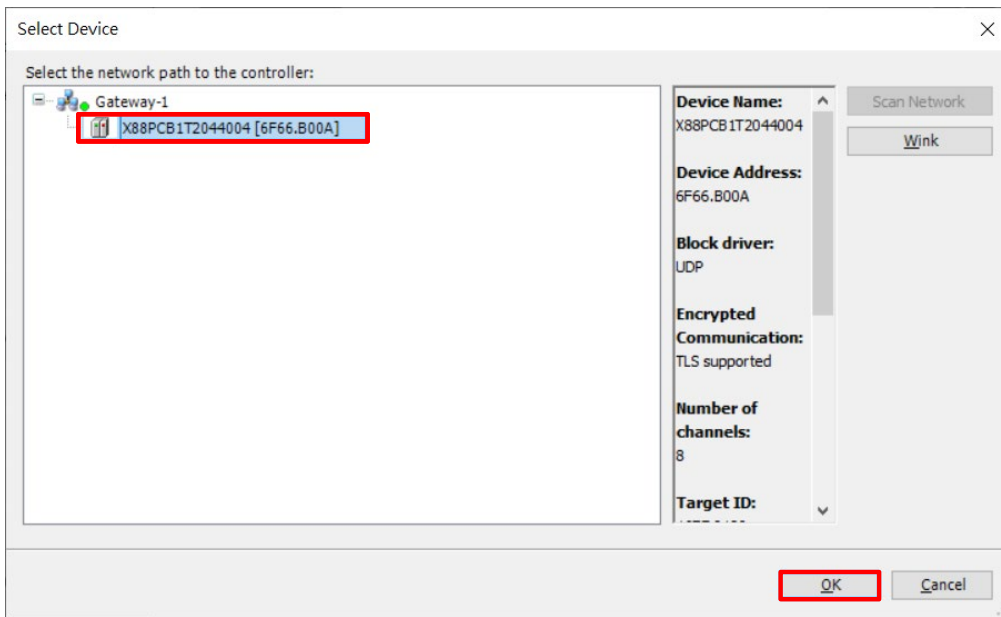

- In the **Devices** window, select **EtherCAT_Master (AX-8xxEP0 Series EtherCAT Master)**, then go to **EtherCAT I/O Mapping** tab to make sure that **Bus Cycle Options** is set as **EtherCAT_Task**.

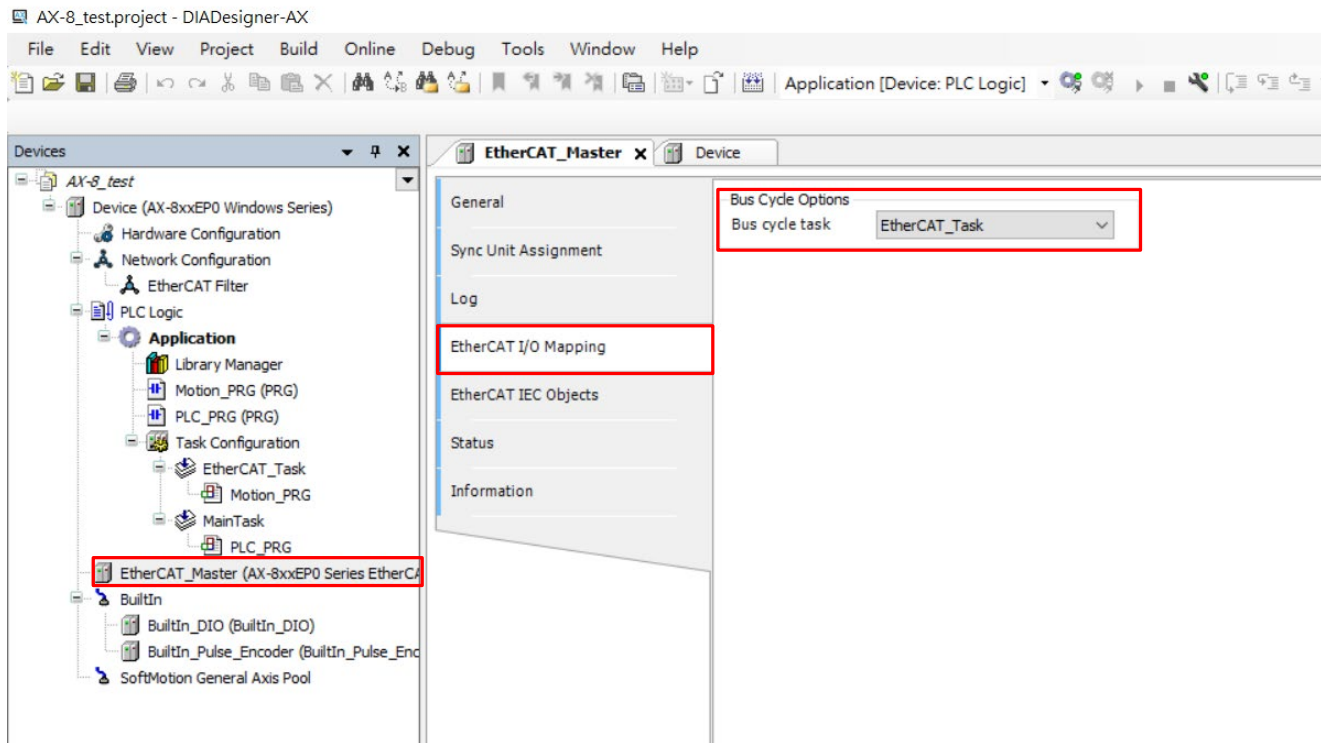

- In the **Devices** window, right click on the **EtherCAT_Master (AX-8xxEP0 Series EtherCAT Master)**, then select **Scan for Devices**.

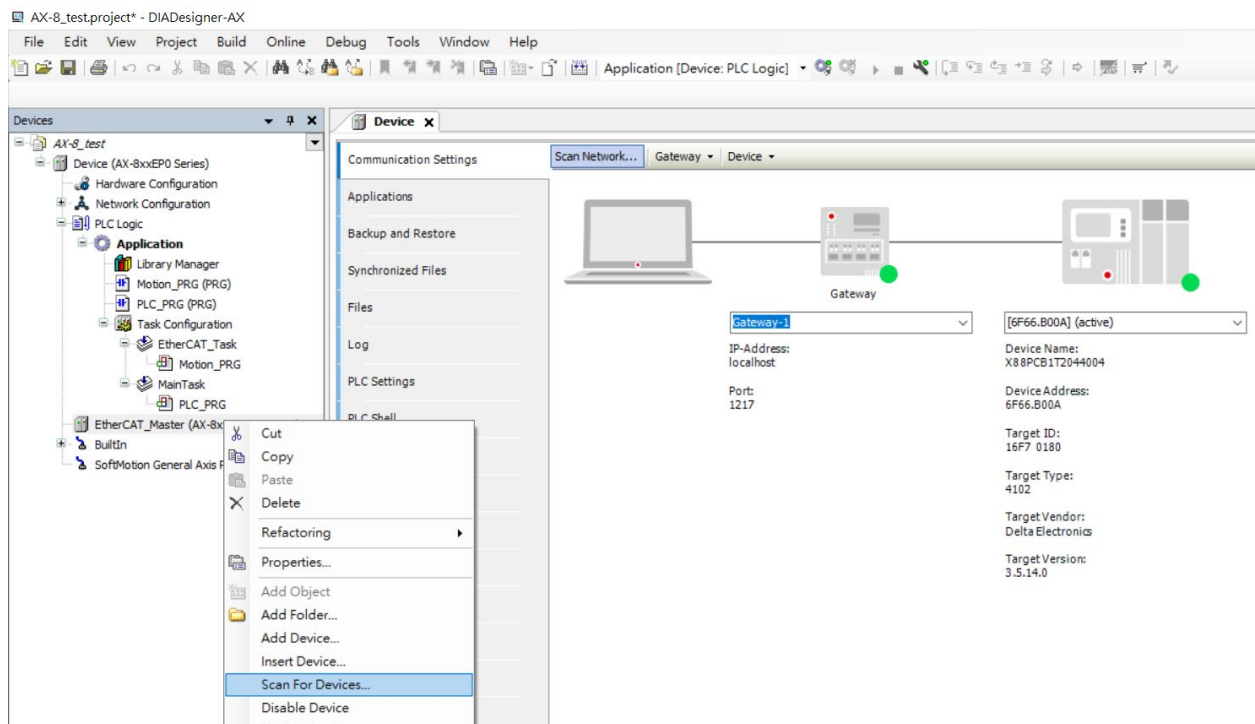

12. The pop-up window shows the description of M300 model. Now select the M300 model description and click **Copy All Devices to project**.

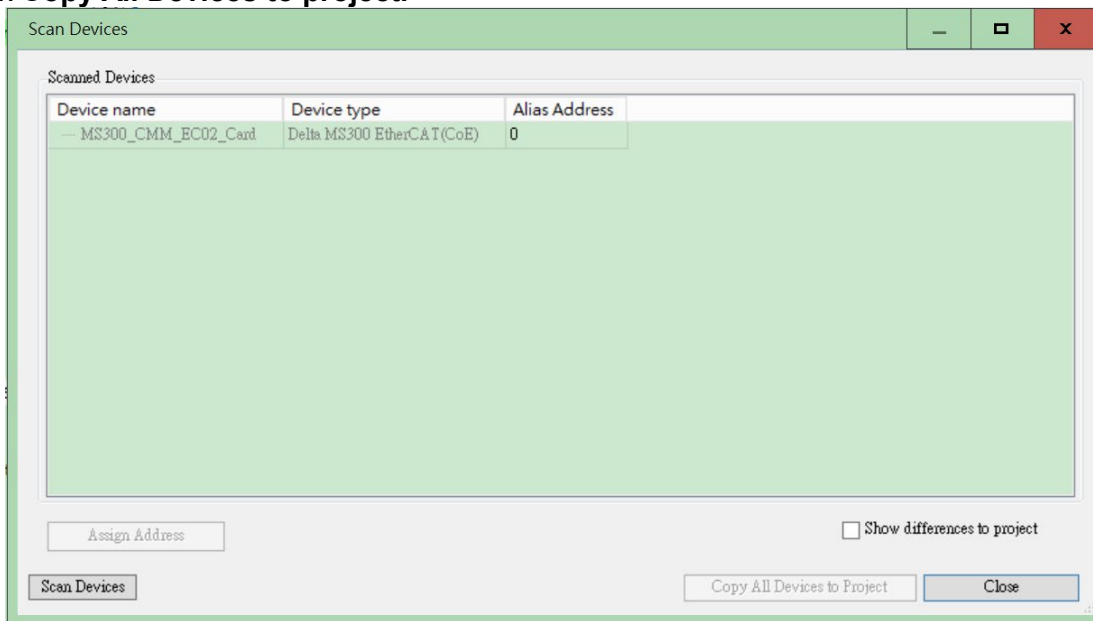

13. If the pop-up window is blank, verify if the wiring between CMM-EC02/ CMM-EC03 and AX-8 is correct. If the pop-up window looks the same as the image below, repeat step 5 to step 7 to import the right ESI file.

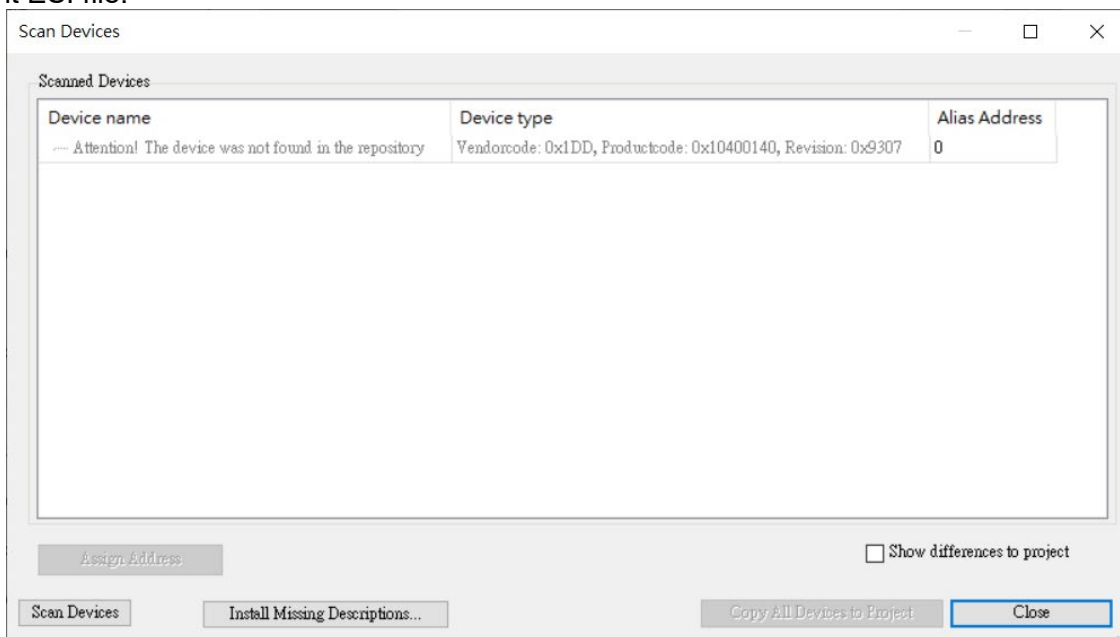

14. In the **Devices** window, double click on **M300_CMC_EC01_Card (Delta M300 EtherCAT (CoE))** to open a tab. In the tab, check the **Enable expert settings**, then on the left side of the tab, click **Expert Process Data** to start PDO reflection.

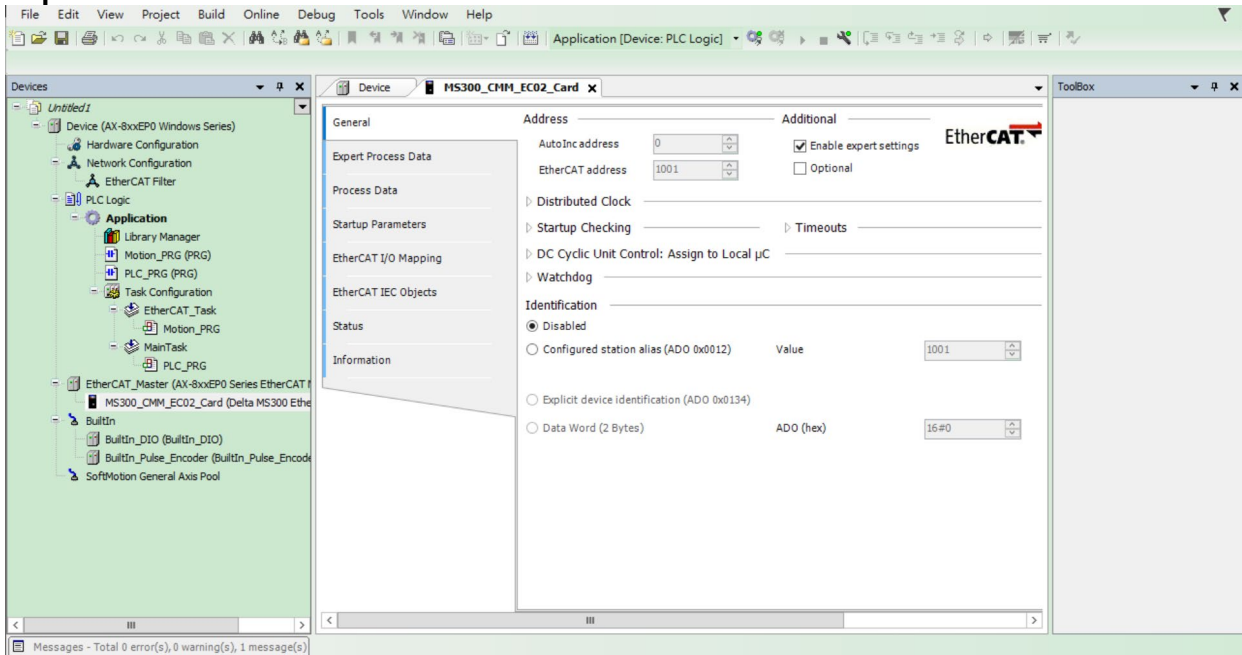

15. In the **Expert Process Data** screen, click on **Insert** in the bottom right corner window.

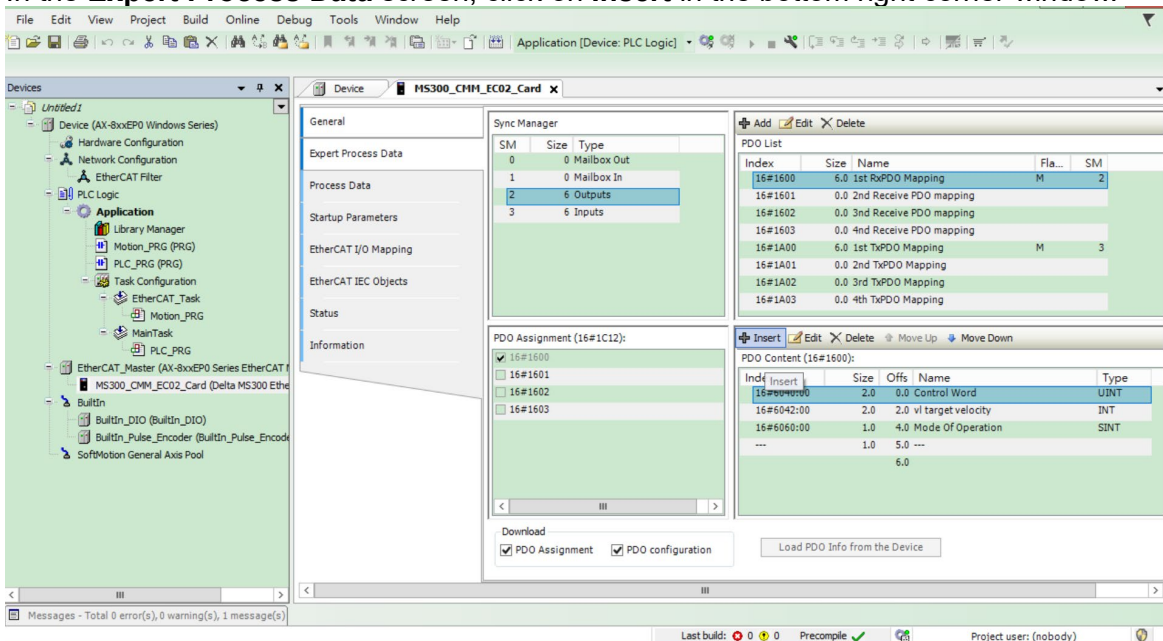

16. A PDO Object mapping window pops up. Select a PDO object to map.

Select Item from Object Directory

Index:Subindex	Name	Flags	Type	Default
16#6040:16#00	Controlword	RW	UINT	
16#6042:16#00	vl target velocity	RW	INT	
16#604F:16#00	vl ramp function time	RW	UDINT	
16#6050:16#00	vl slow down time	RW	UDINT	
16#6060:16#00	Modes of operation	RW	SINT	

Name

Index: 16# Bit length

SubIndex: 16#

Data type

OK Cancel

17. After you finish the steps mentioned above, you've created a framework and you can start programming PLC.

7.2 Delta PLC – AH10EMC Operation Example (ECAT Builder)

Equipment	AH10EMC	IP: 192.168.1.1
	Computer	Network card IP: 192.168.1.123
	Motor drive: MS300 / MH300 Communication card: CMM-EC02/ CMM-EC03	
Software	COMMGR	V1.11 and above
	ISPSOFT	V3.10 and above
	ECAT Builder	V1.07 and above

1. Connect CMM-EC02/ CMM-EC03 to AH10EMC EtherCAT port. Then connect AH10EMC to the computer via Ethernet port.
2. Run COMMGR software, click on the **New Driver** button. Then on the Ethernet tab, select Ethernet in the Connection Setup Type drop-down list. Select the right Ethernet card in the Ethernet Card description drop down list. Then click the Search button, verify if AH10EMC is in the table. Now click on the Save Driver button to start ISPSOFT connection.

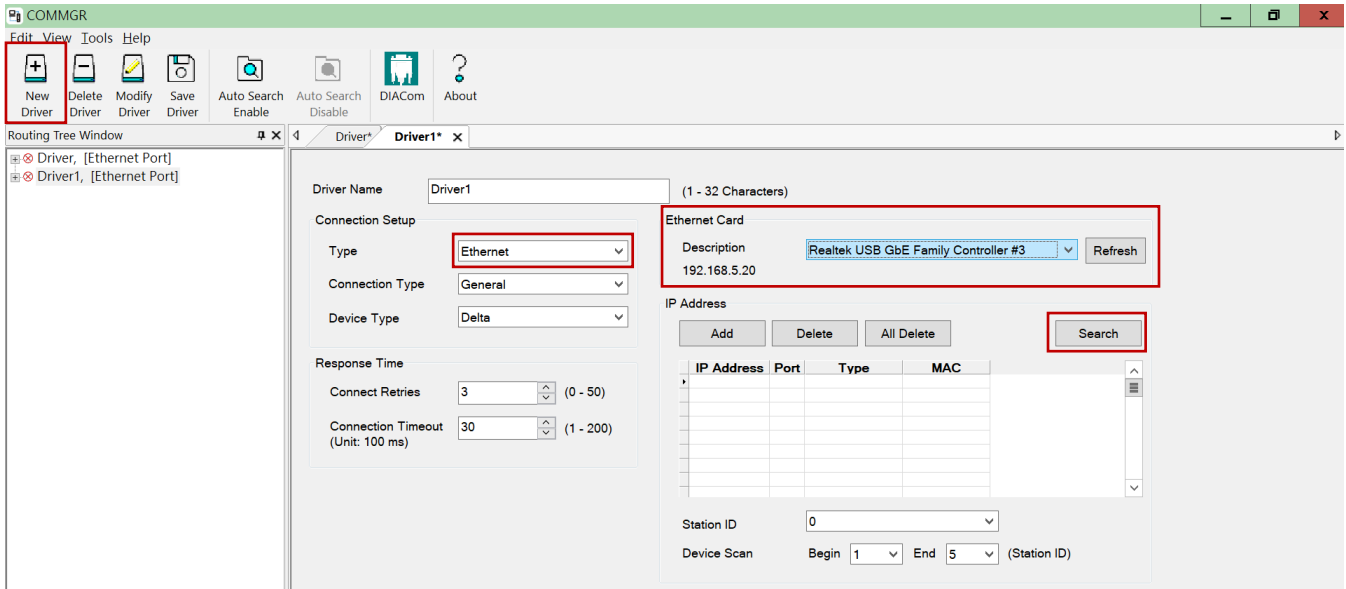

- Run ISPSOft software. Click on icon  to create a new project.

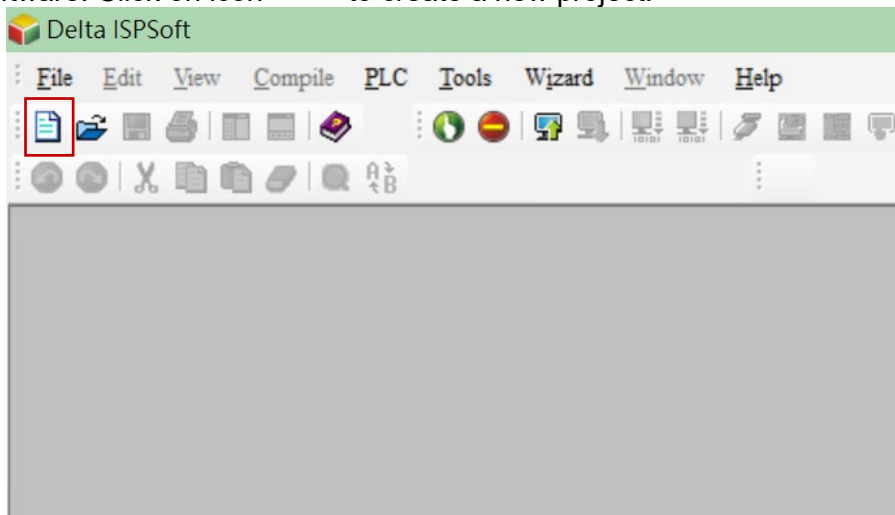

- Select **AH MOTION** as Controller Type. Then select AH10EMC as PLC Type.

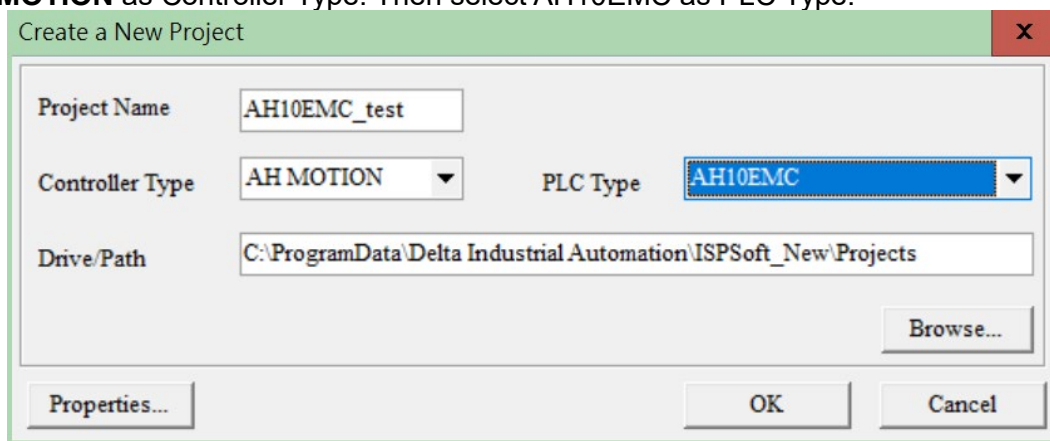

- Click **Tools**, select **Communication Settings**.

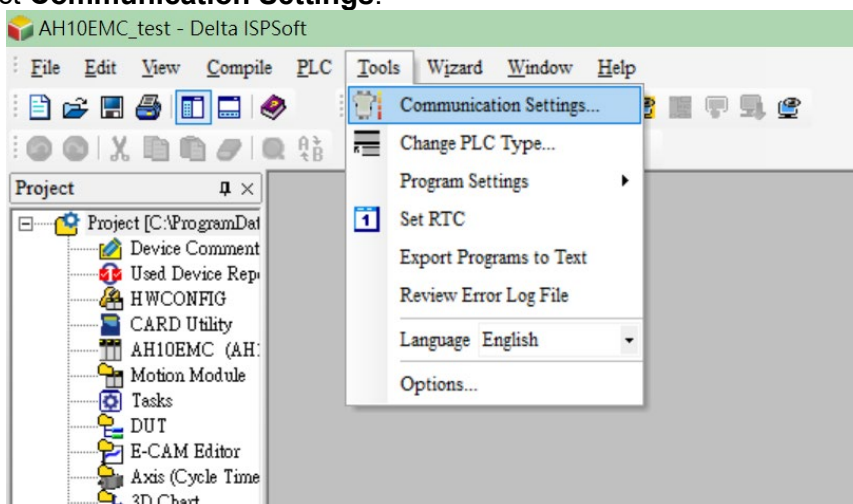

- 6. Select a name for the **Driver** (the driver name which you created in step 2 of COMMGR). Then select an **IP Address** 192.168.1.1.

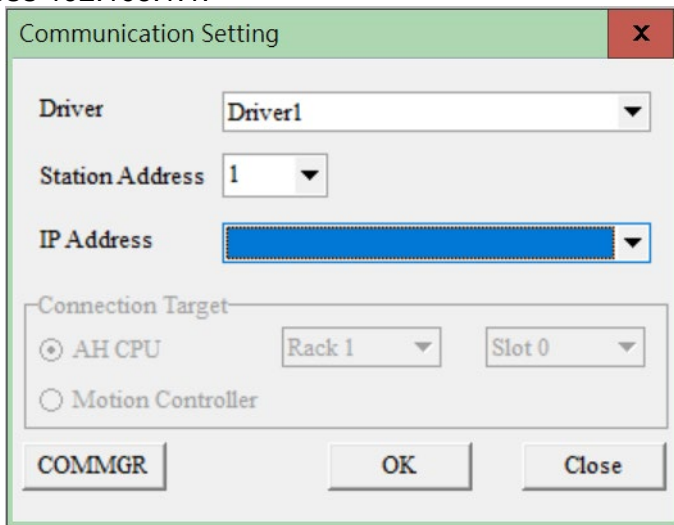

- 7. In the **Project** area, click on **Program** then click **New** to create a blank program.

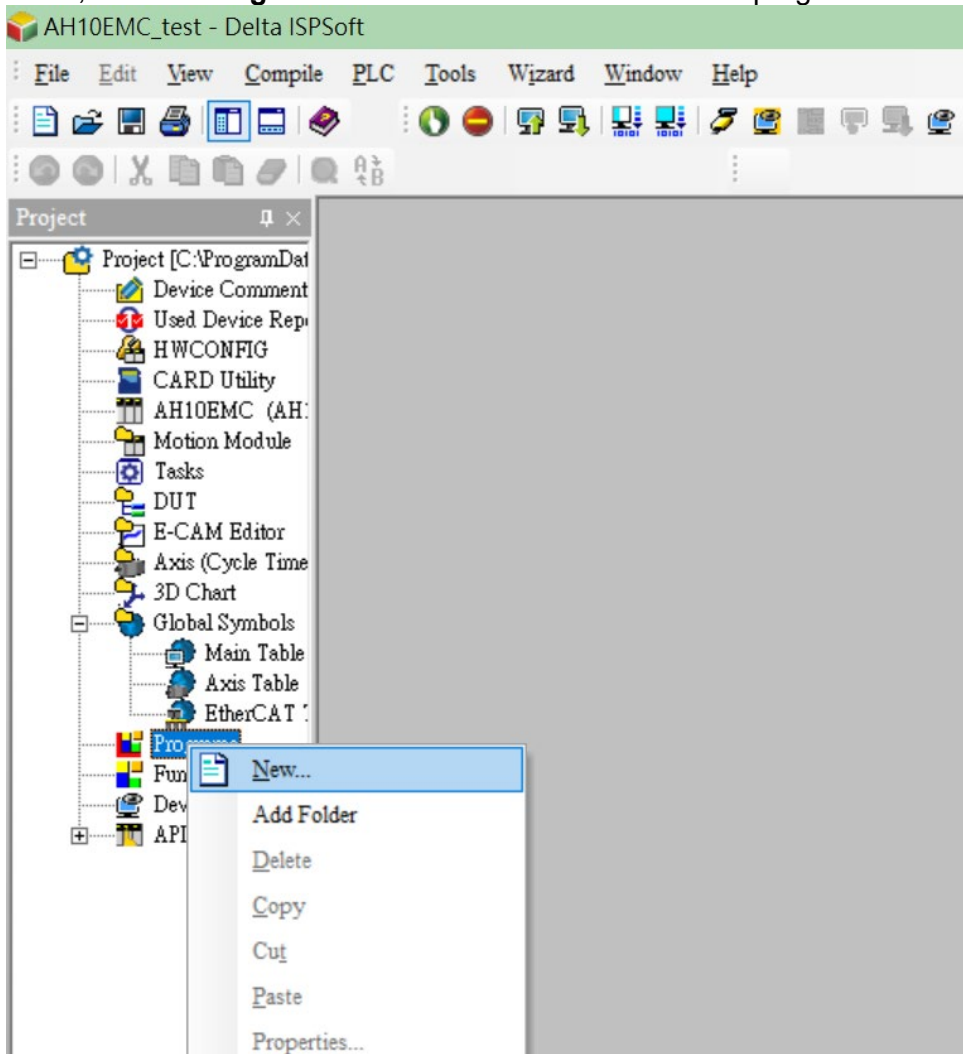

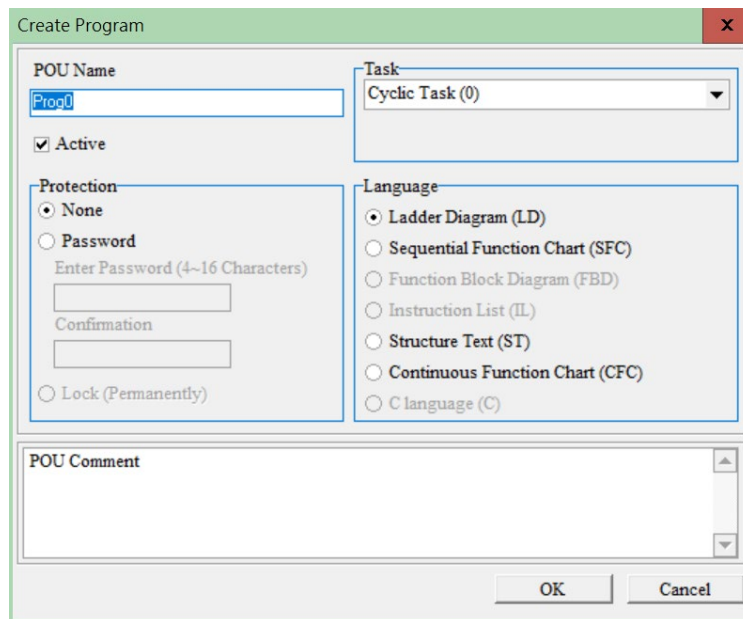

- Click the **Download to PLC** button, as soon as the PLC starts to run, the connection between the PLC and the computer has been established.

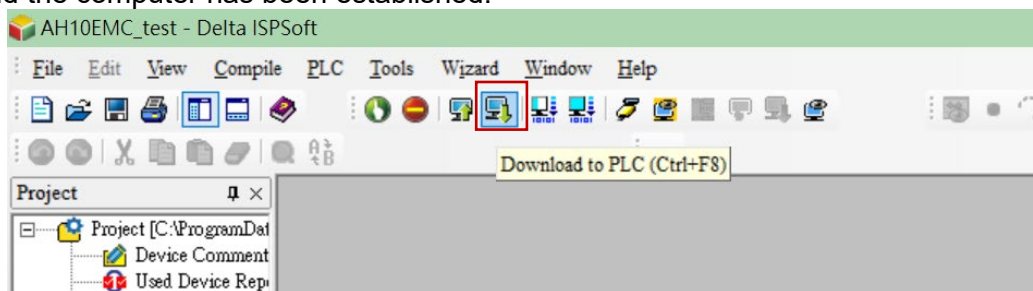

- In the Project area, double click **HWCONFIG**. Click **Upload** button to upload PLC parameters and related settings to HWCONFIG.

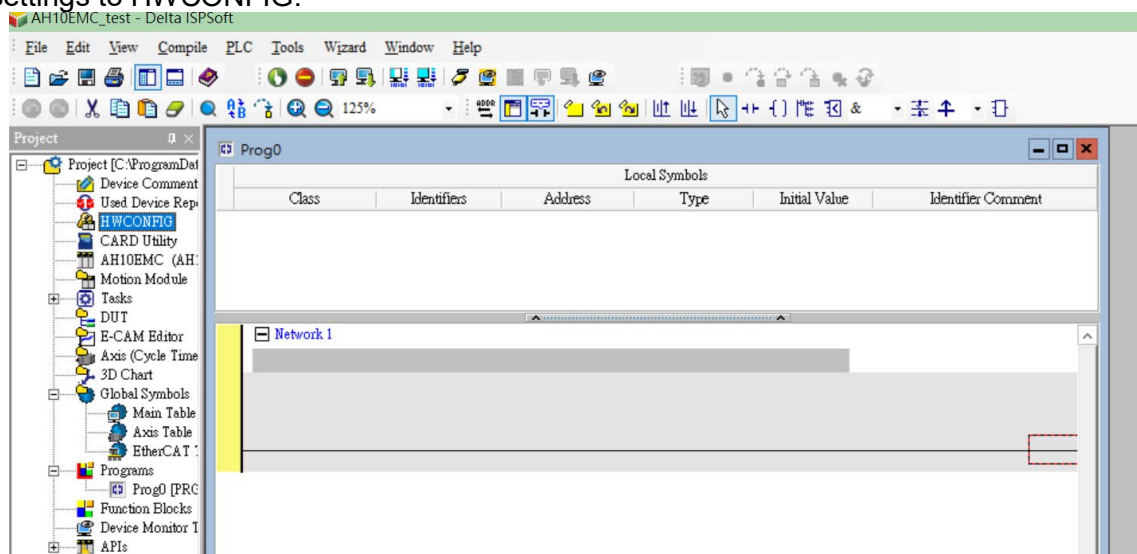

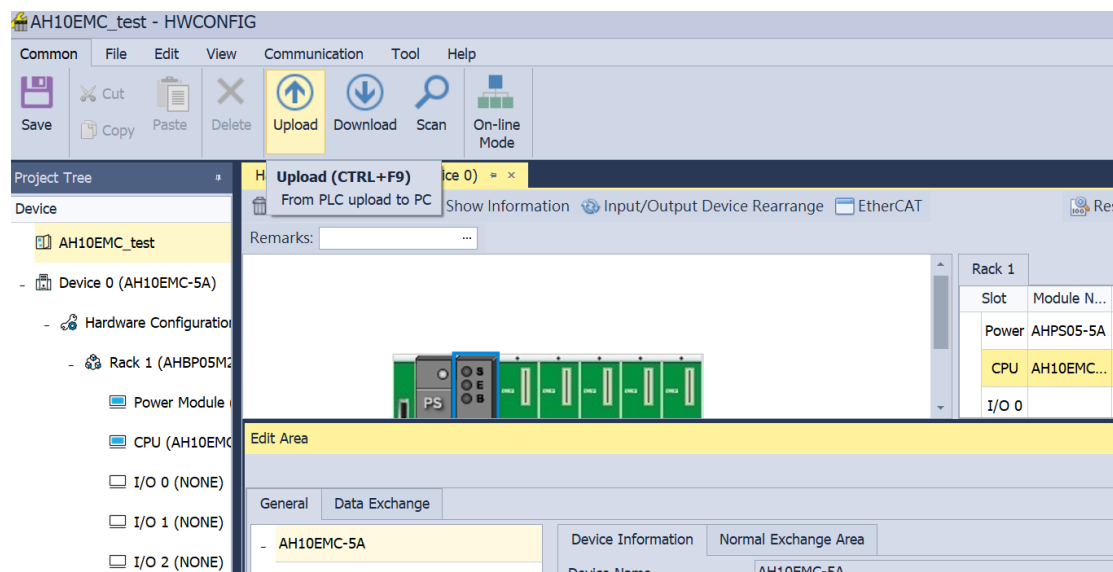

10. Right click on the **CPU module** image as shown below, select **Communication Software** then click **EtherCAT** to do ECAT master / slave station settings in ECAT Builder software.

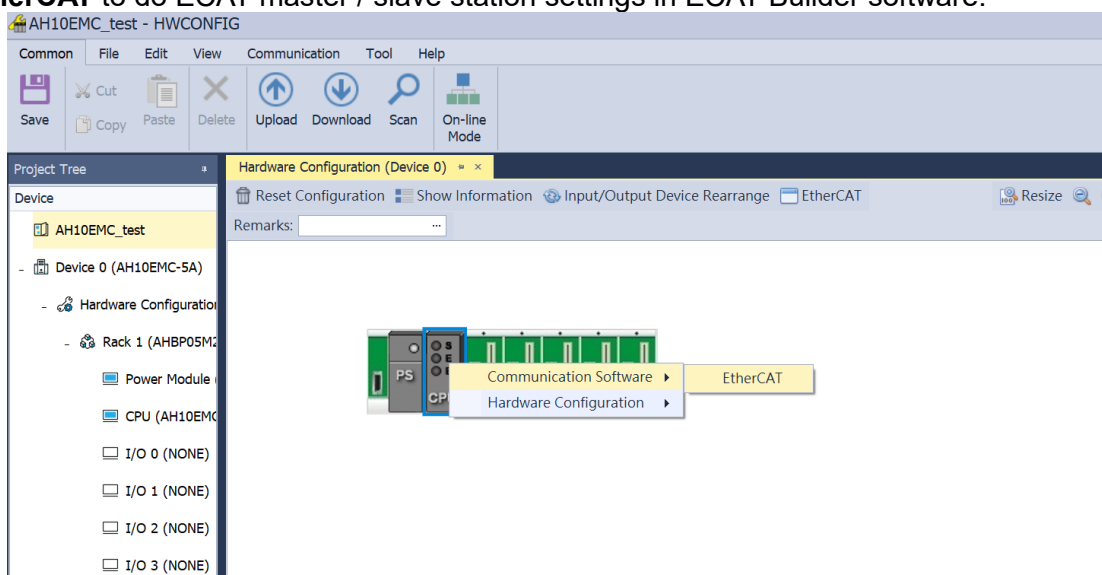

11. Click on the **Network Scan** button, then click **Scan** on the pop-up window. Then select **MS300 / MH300 (CMM-EC02/ CMM-EC03)** in the **Equipment Name** to export to the network. If the scan result doesn't show MS300 / MH300 equipment, verify if the wiring is correct. Refer also to the ESI Import Process at the end of this chapter to import ESI files of slave station and scan again.

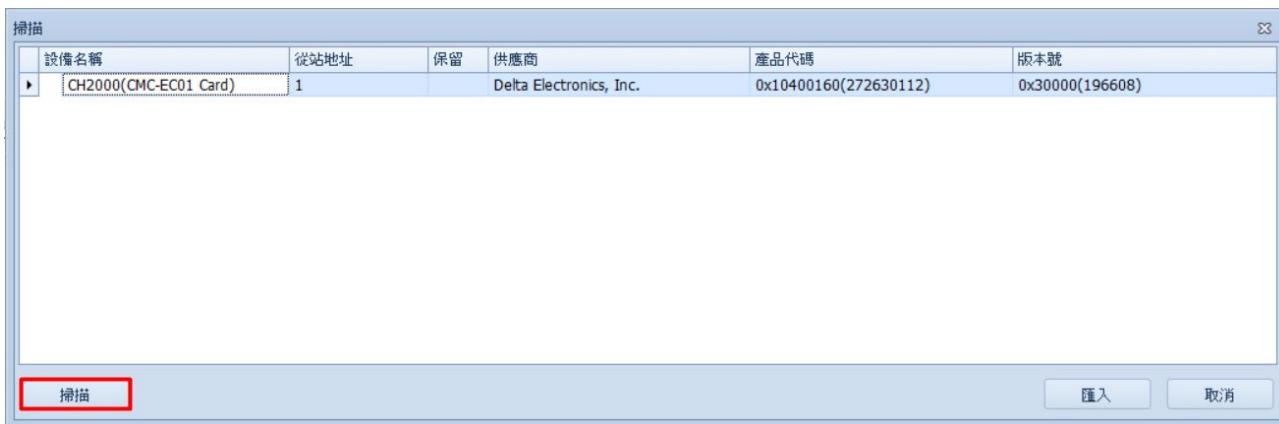
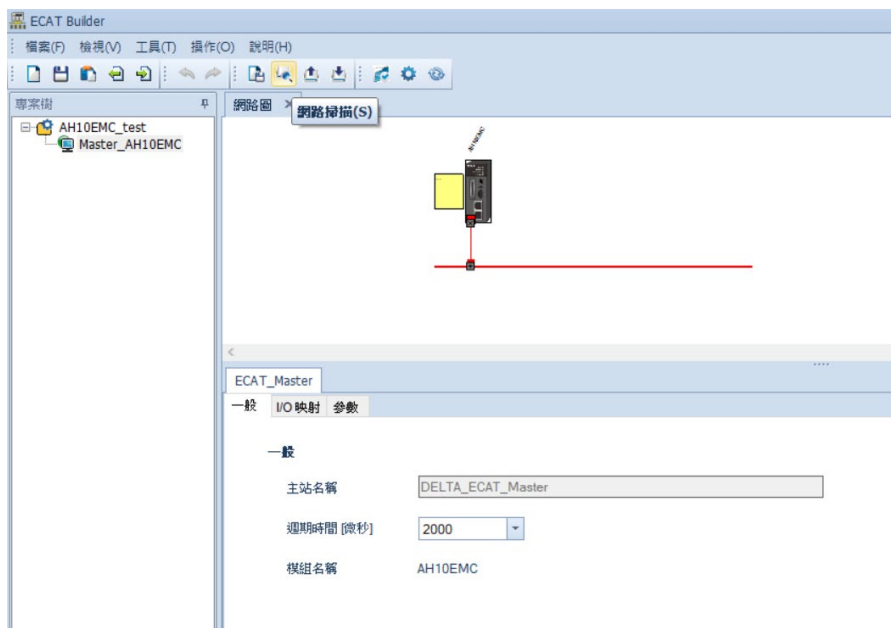

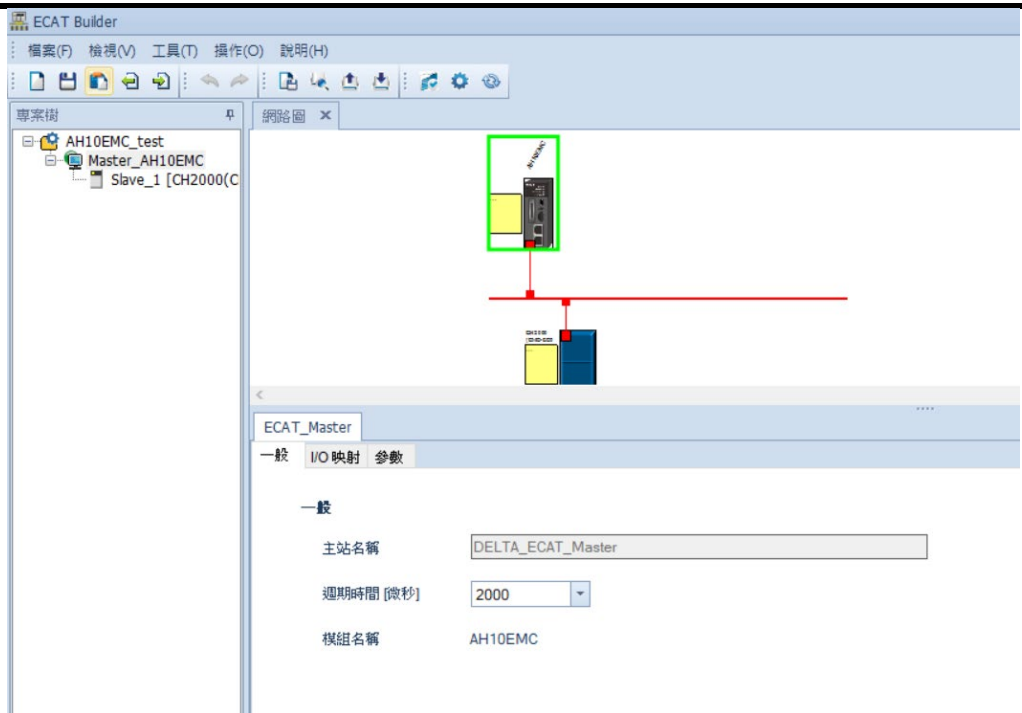

12. Import MS300 / MH300 into **Network Diagram**, then select MS300 / MH300 equipment to do to **PDO mapping**. Click **Edit** to add or delete objects.

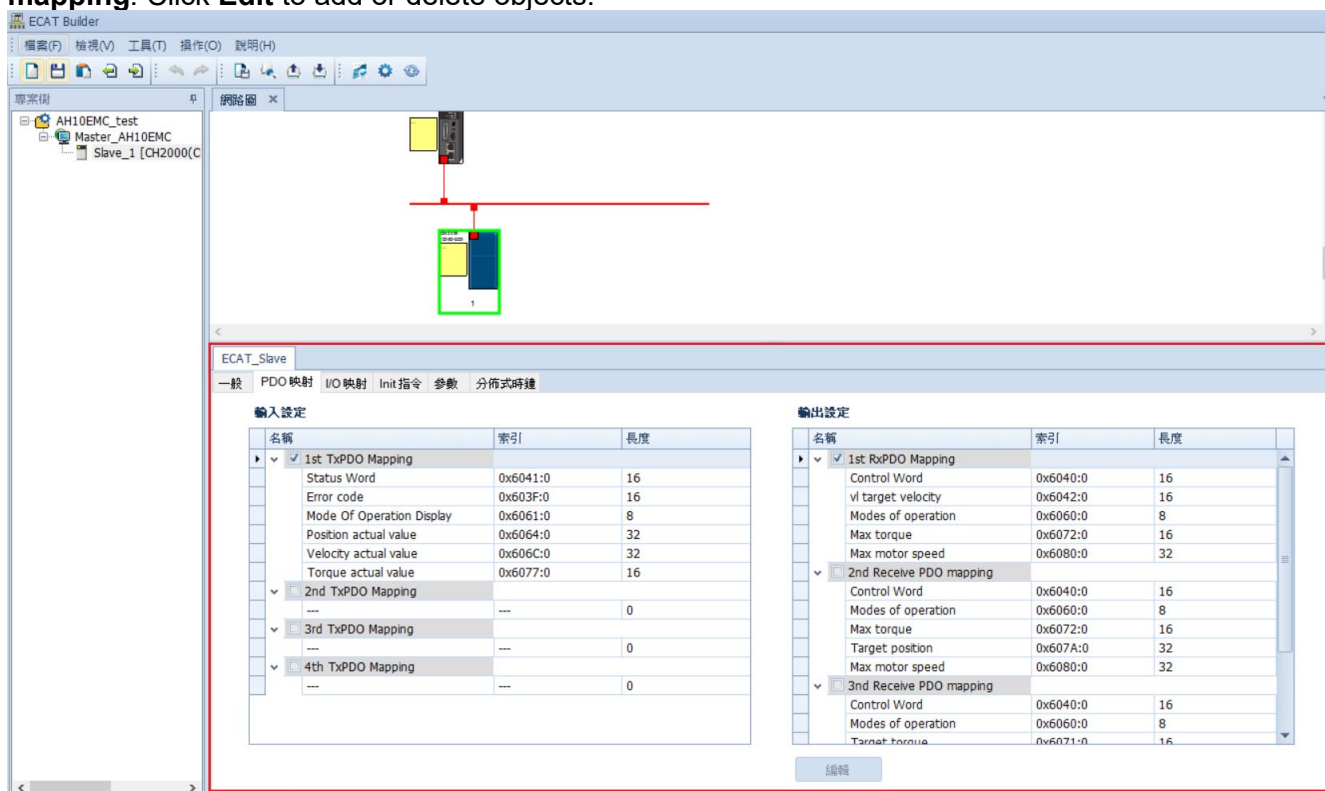

編輯 PDO
☰

一般

名稱:

索引: Dec Hex

旗標

強制性

固定內容

虛擬 PDO

方向

TxPDO

RxPDO

選項

排除:

- 0x1A01
- 0x1A02
- 0x1A03

項目

	名稱	索引	Bit 長度	註解
▶	Status Word	0x6041:0	16	
	vl velocity demand	0x6043:0	16	
	Mode Of Operation Display	0x6061:0	8	
		--	8	

13. After you finish editing, click the **Download** button to download all the settings to the AH10EMC. Close ECAT Builder and HWCONFIG, then start programming PLC in the ISPSOft

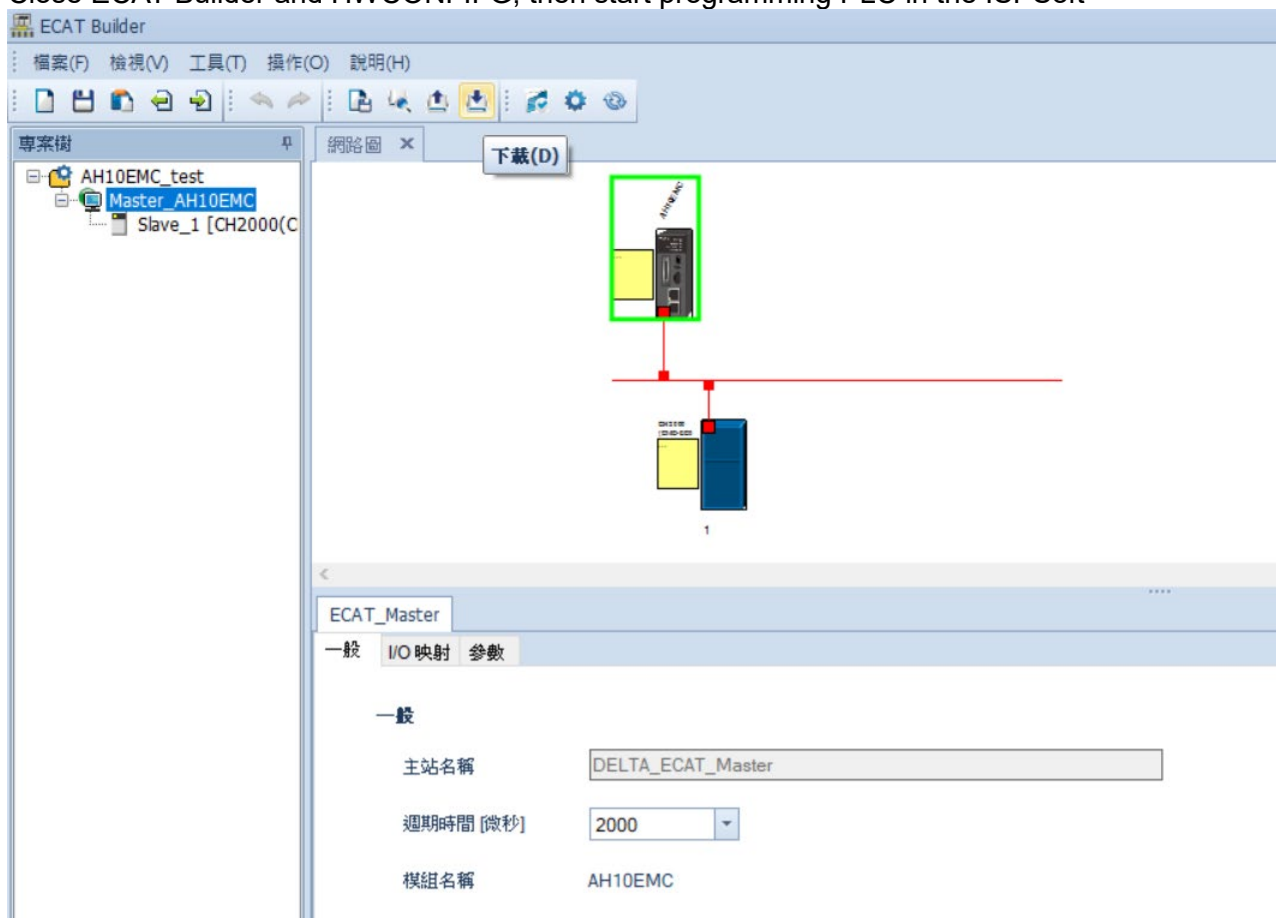

- Import the ESI file
Click **DDF Management Tool** button, then follow step by step to import the ESI file. You can download ESI file in Delta's download center (See section 2.5).

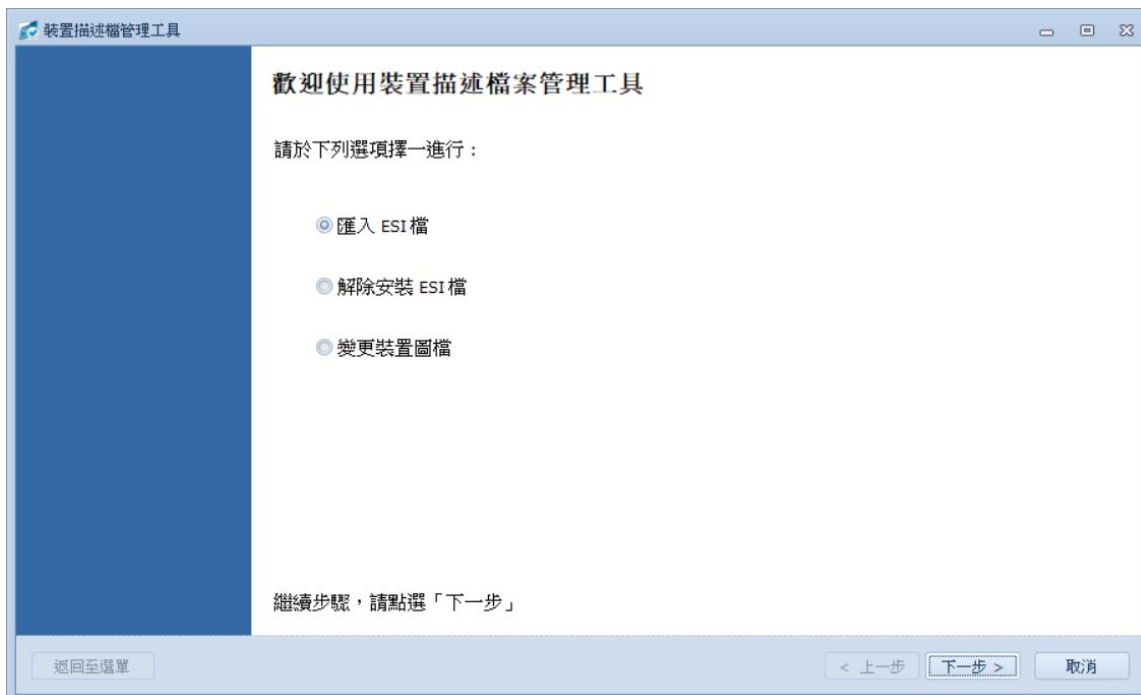
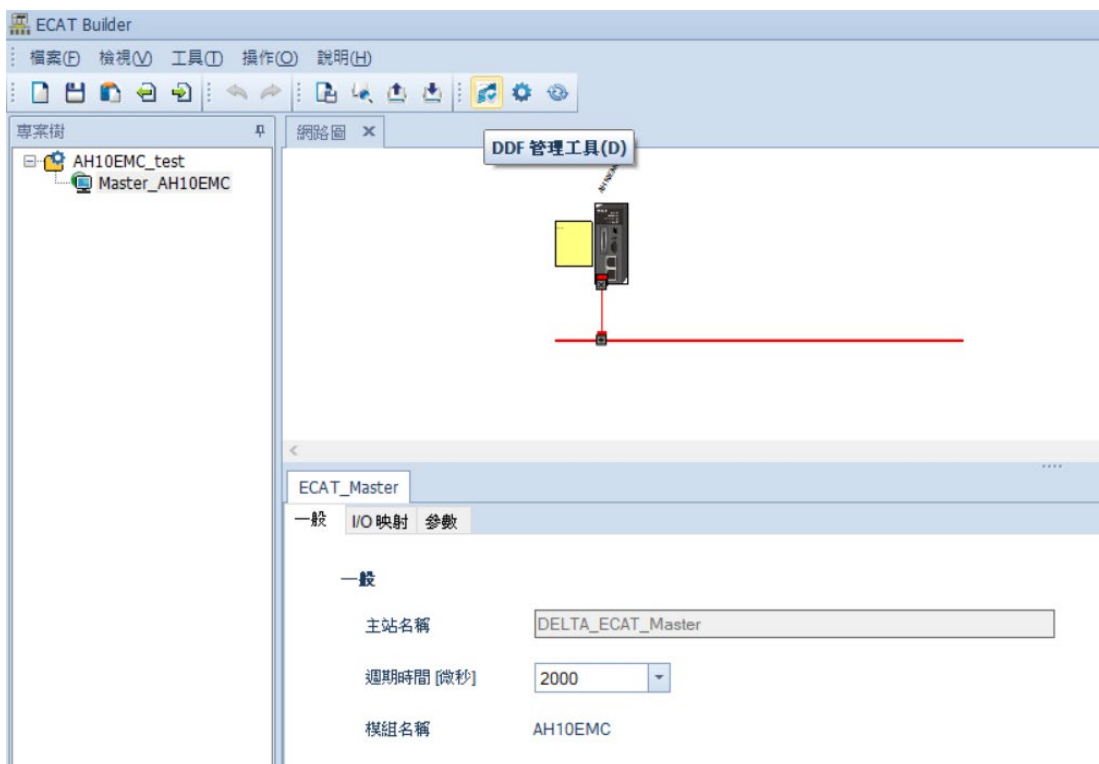

Appendix A.

A.1 Description of Object Specification

A.1.1 Object Type

Object Type	Description
Variable	A single value such as a UNSIGNED8, a Boolean, a float and an INTEGER16
Array	An object with multiple data fields composed of multiple variables of the same data type such as UNSIGNED16. The Sub-index 0 data belongs to UNSIGNED8, so it's not classified as array data
Record	An object with multiple data fields composed of multiple variables of the same data type. The Sub-index 0 data belongs to UNSIGNED8, so it's not classified as record data.

A.1.2 Data Type

Data Type	Data Size	Range
BOOLEAN	1 bit	0~1
UNSIGNED8	1 byte	0~255
UNSIGNED16	2 bytes	0~65535
UNSIGNED32	4 bytes	0~4294967295
INTEGER8	1 byte	-128~127
INTEGER16	2 bytes	-32768~32767
INTEGER32	4 bytes	-2147483648~2147483647
VISIBLE STRING	-	-

A.2 Object Dictionary

A.2.1 OD 1000h Communication Group

Index	Object Type	Name	Data Type	Attribute
1000h	Variable	Device type	UNSIGNED32	RO
1001h	Variable	Error register	UNSIGNED8	RO
1008h	Variable	Device name	STRING	RO
100Ah	Variable	Software version	STRING	RO
1018h	Record	Identity	IDENTITY	RO
1600h	Record	Receive PDO mapping	PDOMAPPING	RW
1A00h	Record	Transmit PDO mapping	PDOMAPPING	RW
1C12h	Array	RxPDO assign	UNSIGNED16	RW
1C13h	Array	TxPDO assign	UNSIGNED16	RW

A.2.2 OD 3000h Motor Drive's Parameter Group

The objects defined here are related to the settings of the motor drive's parameters. The setting methods are as follows:

Index 300Xh are related to motor drive's parameter Group X. The sub-index 1h~64h (hexadecimal) correspond to the parameter Group X-00 to Group X-99.

For example: Set Pr.05-33 (Induction motor or permanent magnet synchronous motors selection). The Index is 3005h and the sub-index is 22h (34).

A.2.3 OD 6000h Communication Object Group

Index	Object Type	Name	Data Type	Attribute	PDO Mapping
6007h	Variable	Abort connection option code	INTEGER16	RW	N
603Fh	Variable	Error code	UNSIGNED16	RO	Y
6040h	Variable	Controlword	UNSIGNED16	RW	Y
6041h	Variable	Statusword	UNSIGNED16	RO	Y
6042h	Variable	vl target velocity	INTEGER16	RW	Y
6043h	Variable	vl velocity demand	INTEGER16	RO	N
6044h	Variable	vl velocity actual value	INTEGER16	RO	Y
604Fh	Variable	vl ramp function time	INTEGER16	RW	N
6050h	Variable	vl slow down time	INTEGER16	RW	N
6051h	Variable	vl quick stop time	INTEGER16	RW	N
605Ah	Variable	Quick stop option code	INTEGER16	RW	N
605Ch	Variable	Disable operation option code	INTEGER16	RW	N
6060h	Variable	Modes of operation	INTEGER8	RW	Y
6061h	Variable	Modes of operation display	INTEGER8	RO	Y
6502h	Variable	Supported drive modes	INTEGER32	RO	N

A.3 Detailed Information about Objects

A.3.1 OD 1000h Communication Group

Object 1000h : Device type

Index	1000h
Name	Device type
Object Type	Variable
Data Type	UNSIGNED32
Read-Write Permission	RO
PDO Mapping Setting	No
Setting Range	UNSIGNED32

Object 1001h : Error register

Index	1001h
Name	Error register
Object Type	Variable
Data Type	UNSIGNED8
Read-Write Permission	RO
PDO Mapping Setting	No
Setting Range	UNSIGNED8

Object 1008h : Device name

Index	1008h
Name	Device name
Object Type	Variable
Data Type	STRING
Read-Write Permission	RO
PDO MAPPING SETTING	No

Object 100Ah : Software version

Index	100Ah
Name	Software version
Object Type	Variable
Data Type	STRING
Read-Write Permission	RO
PDO MAPPING SETTING	No

Object 1018h : Identity

Index	1018h
Name	Identity
Object Type	RECORD
Read-Write Permission	RO
PDO MAPPING SETTING	No

Sub-Index	0
Name	SubIndex 000
Data Type	UNSIGNED8
Read-Write Permission	RO
PDO MAPPING SETTING	No
Setting Range	UNSIGNED8

Sub-Index	1
Name	Vendor ID
Data Type	UNSIGNED32
Read-Write Permission	RO
PDO MAPPING SETTING	No
Setting Range	UNSIGNED32

Sub-Index	2
Name	Product code
Data Type	UNSIGNED32
Read-Write Permission	RO
PDO MAPPING SETTING	No
Setting Range	UNSIGNED32

Sub-Index	3
Name	Revision
Data Type	UNSIGNED32
Read-Write Permission	RO
PDO MAPPING SETTING	No
Setting Range	UNSIGNED32

Sub-Index	4
Name	Serial number
Data Type	UNSIGNED32
Read-Write Permission	RO
PDO MAPPING SETTING	No
Setting Range	UNSIGNED32

Object 1600h~1603h : Receive PDO Mapping Parameter

Index	1600h / 1601h / 1602h / 1603h
Name	Receive PDO mapping
Object Type	RECORD
Data Type	PDO mapping
Read-Write Permission	RW
PDO MAPPING SETTING	No
Note	The total length of a PDO set cannot be longer than 64-bit.

Sub-Index	0
Name	Number of Objects
Data Type	UNSIGNED8
Read-Write Permission	RW
PDO MAPPING SETTING	No
Setting Range	0: Disable 1~8: Set number of PDO mapping and enable this function.
Factory Setting	0

Sub-Index	1~8
Name	Mapping entry (n)
Data Type	UNSIGNED32
Read-Write Permission	RW
PDO MAPPING SETTING	No
Setting Range	UNSIGNED32
Factory Setting	0

Object 1A00h~1A03h : Transmit PDO Mapping Parameter

Index	1A00h / 1A01h / 1A02h / 1A03h
Name	Transmit PDO Mapping Parameter
Object Type	RECORD
Data Type	PDO mapping
Read-Write Permission	RW
Note	The total length of a PDO set cannot be longer than 64-bit.

Sub-Index	0
Name	Number of Objects
Data Type	UNSIGNED8
Read-Write Permission	RW
PDO MAPPING SETTING	No
Setting Range	0: Disable 1~8: Set number of PDO mapping and enable this function.
Factory Setting	0

Sub-Index	1~8
Name	Mapping entry (n)
Data Type	UNSIGNED32
Read-Write Permission	RW
PDO MAPPING SETTING	No
Setting Range	UNSIGNED32
Factory Setting	0

Object 1C12h : RxPDO assign

Index	1C12h
Name	RxPDO assign
Object Type	ARRAY
Data Type	UNSIGNED16
Read-Write Permission	RW
PDO MAPPING SETTING	No

Sub-Index	0
Name	Number of assigned RxPDOs
Data Type	UNSIGNED8
Read-Write Permission	RW
PDO MAPPING SETTING	No
Setting Range	0~1
Factory Setting	1

Sub-Index	1
Name	Index of assigned RxPDO
Data Type	UNSIGNED16
Read-Write Permission	RW
PDO MAPPING SETTING	No
Setting Range	0x1600 / 0x1601 / 0x1602 / 0x1603
Factory Setting	0x1600

Object 1C13h : TxPDO assign

Index	1C13h
Name	TxPDO assign
Object Type	ARRAY
Data Type	UNSIGNED16
Read-Write Permission	RW
PDO MAPPING SETTING	No

Sub-Index	0
Name	Number of assigned TxPDOs
Data Type	UNSIGNED8
Read-Write Permission	RW
PDO MAPPING SETTING	No
Setting Range	0~1
Factory Setting	1

Sub-Index	1
Name	Index of assigned TxPDO
Data Type	UNSIGNED16
Read-Write Permission	RW
PDO MAPPING SETTING	No
Setting Range	0x1A00 / 0x1A01 / 0x1A02 / 0x1A03
Factory Setting	0x1A00

A.3.2 OD 3000h Motor Drive's Parameter Group

Index	3XXXh
Name	Driver parameter
Object Type	Variable
Data Type	UNSIGNED16
Read-Write Permission	RW
PDO MAPPING SETTING	No
Setting Range	UNSIGNED16
Factory Setting	N/A

You can read/write motor drive's parameters via this object group. The motor drive's parameter can only be changed by SDO.

The setting methods are as follows:

Index 300Xh are related to motor drive's parameter Group X. The sub-index 1h~64h (hexadecimal) correspond to the parameter Group X-00 to Group X-99.

For example: Set Pr.05-33 (Induction motor or permanent magnet synchronous motors selection). The Index is 3005h and the sub-index is 22h (34).

A.3.3 OD 6000h Communication Object Group

Object 6007h : Abort connection option code

Index	6007h
Name	Abort connection option code
Object Type	Variable
Data Type	INTEGER16
Read-Write Permission	RW
PDO MAPPING SETTING	No
Setting Range	0: No function 2: Switch on Disable 3: Quick Stop
Factory Setting	2

- When object 6007h = 0, CANopen ignores a disconnection fault, no warning and do nothing.
- When object 6007h =2, CANopen turns to **Switch on Disable** and displays ECto. CANopen then follows the setting at object 605Ah to trigger parking. When reconnection is successful, the warning code disappears.
- When object 6007h = 3, CANopen turns to Quick Stop and displays ECto. CANopen then follows the setting at object 605Ch to trigger parking. When reconnection is successful, the warning code clears.

Object 603Fh : Error code

Index	603Fh
Name	Error code
Object Type	Variable
Data Type	UNSIGNED16
Read-Write Permission	RO
PDO MAPPING SETTING	Yes
Setting Range	UNSIGNED32
Factory Setting	0

Object 6040h : Controlword

Index	6040h
Name	Controlword
Object Type	Variable
Data Type	UNSIGNED16
Read-Write Permission	RW
PDO MAPPING SETTING	Yes
Setting Range	UNSIGNED16
Factory Setting	0

Description of different bits

Bit	Function	Description
Bit 0	Switch on	-
Bit 1	Enable voltage	-
Bit 2	Quick stop	-
Bit 3	Enable operation	-
Bit 4~Bit 6	Operation mode specific	Refer to the Specific Model Definition table blow
Bit 7	Fault reset	-
Bit 8	Halt	-
Bit 9~Bit 15	Reserved	-

Specific Model Definition table:

Bit	Specific Model Definition						
	VL	PP	Homing	IP	PT	CSP	CST
Bit 4	Enable ramp	New set-point	Homing operation start	Enable interpolation	-	-	-
Bit 5	Unlock ramp	Change set immediately	-	-	-	-	-
Bit 6	Reference ramp	0: Absolute target position 1: Relative target position	-	-	-	-	-
Bit 8	Halt	Halt	Halt	Halt	-	-	-

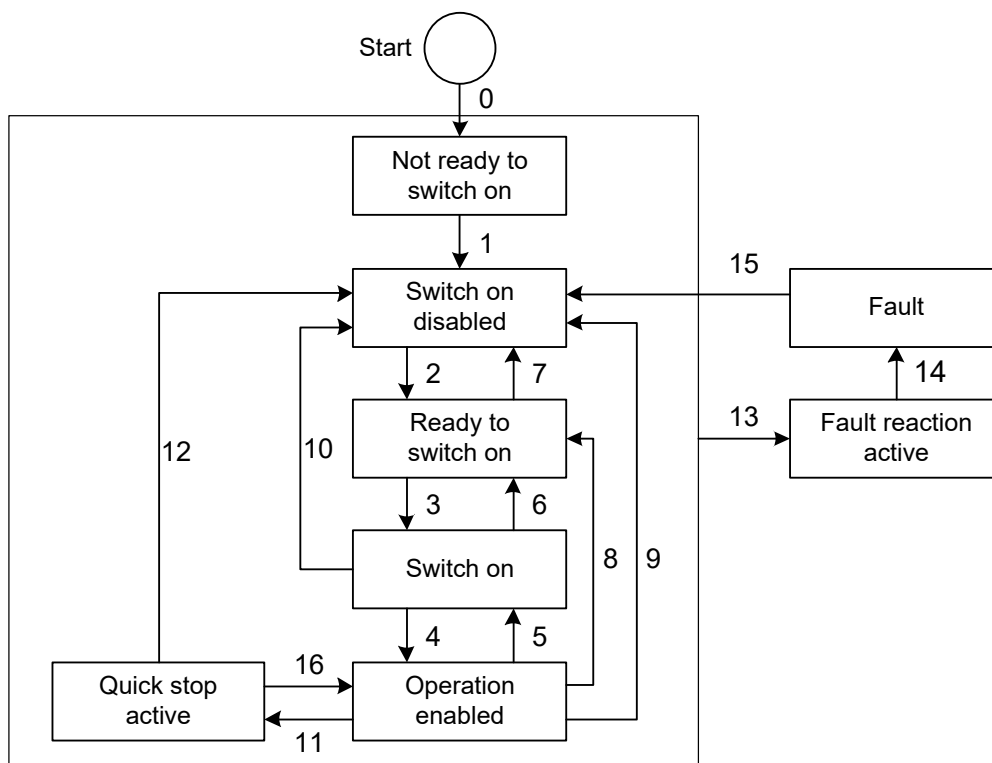

Status Switching Definition table

Status Switching	Event	Action
0 \ 1	Auto run after powering on	Activate the device and initialize.
2	Shutdown command	N/A
3	Switch on command	Motor drive prepares for servo on
4	Enable operation command	Motor drive has servo on and is in operation.
5	Disable operation command	Servo has servo off.
6	Shutdown command	N/A
7	Disable voltage or Quick stop command	N/A
8	Shutdown command	Motor drive has servo off.
9	Disable voltage command	Motor drive has servo off.
10	Disable voltage or Quick stop command	N/A
11	Quick stop command	Enable Quick Stop function.
12	Disable voltage command	Motor drive has servo off
13 \ 14	Warning / Fault codes pop up	Motor drive has servo off.
15	Warning / Fault codes clear	N/A
16	Enable operation ; no alarm command	Restart operation command.

Via Controlword (6040h), status can be changed, the commands are as follows:

Command	Bit of Controlword (6040h)					Status Change
	Bit 7	Bit 3	Bit 2	Bit 1	Bit 0	
Shutdown	0	X	1	1	0	2 \ 6 \ 8
Switch on	0	0	1	1	1	3
Switch on + Enable operation	0	1	1	1	1	3 + 4
Disable voltage	0	X	X	0	X	7 \ 9 \ 10 \ 12
Quick stop	0	X	0	1	X	7 \ 10 \ 11
Disable operation	0	0	1	1	1	5
Enable operation	0	1	1	1	1	4 \ 16
Fault reset		X	X	X	X	15

NOTE: 0 = Bit is off; 1 = Bit is on; X = Bit is not affected;  = positive edge triggering

Object 6041h : Statusword

Index	6041h
Name	Statusword
Object Type	Variable
Data Type	UNSIGNED16
Read-Write Permission	RO
PDO MAPPING SETTING	Yes
Setting Range	UNSIGNED16
Factory Setting	0

Description of different bits

Bit	Function	Description
Bit 0	Ready to switch on	Bit 0 to Bit6 display current status of the motor drive. See table below for details.
Bit 1	Switched on	
Bit 2	Operation enabled	
Bit 3	Fault	
Bit 4	Voltage enabled	
Bit 5	Quick stop	
Bit 6	Switch on disabled	
Bit 7	Warning	Warning status: motor drive still has servo on.
Bit 8	Reserved	-
Bit 9	Remote	-
Bit 10	Target reached	Target reached
Bit 11	Reserved	-
Bit 12~Bit 13	Operation mode specific	See Specific Model Definition table below.
Bit 14	Reserved	-
Bit 15	Reserved	-

Bit 6	Bit 5	Bit 4	Bit 3	Bit 2	Bit 1	Bit 0	Description
0	-	-	0	0	0	0	Not ready to switch on
1	-	-	0	0	0	0	Switch on disabled
0	1	-	0	0	0	1	Ready to switch on
0	1	-	0	0	1	1	Switch on
0	1	-	0	1	1	1	Operation enabled
0	0	-	0	1	1	1	Quick stop active
0	-	-	1	1	1	1	Fault reaction active
0	-	-	1	0	0	0	Fault

NOTE: 0 = bit is off; 1 = bit is on; - means that bit is not functional.

Specific Model Definition table:

Bit	Specific Model Definition						
	VL	PP	Homing	IP	PT	CSP	CST
Bit 10	-	Target reached	Target reached	Target reached	Target reached	-	-
Bit 12	-	-	Homing attained	-	-	-	-
Bit 13	-	Following error	Homing error	Following error	-	Following error	-

Object 6042h : vl target velocity

Index	6042h
Name	vl target velocity
Object Type	Variable
Data Type	INTEGER16
Read-Write Permission	RW
PDO MAPPING SETTING	Yes
Setting Range	INTEGER16
Factory setting	0
Unit	RPM

This object is a velocity command value under the velocity mode.

Object 6043h : vl velocity demand

Index	6043h
Name	vl velocity demand
Object Type	Variable
Data Type	INTEGER16
Read-Write Permission	RO
PDO MAPPING SETTING	No
Setting Range	INTEGER16
Unit	RPM

This object is a velocity command calculated by the motor drive under the velocity mode.

Object 6044h : vl velocity actual value

Index	6044h
Name	vl velocity actual value
Object Type	Variable
Data Type	INTEGER16
Read-Write Permission	RO
PDO MAPPING SETTING	Yes
Setting Range	INTEGER16
Unit	RPM

This object is the actual running speed under the velocity mode.

Object 604Fh : vl ramp function time

Index	604Fh
Name	vl ramp function time
Object Type	Variable
Data Type	UNSIGNED32
Read-Write Permission	RW
PDO MAPPING SETTING	No
Setting Range	UNSIGNED32
Factory setting	10000
Unit	ms

This object is the time spent when the motor drive accelerates from 0 RPM to 6042h under the Velocity Mode.

Object 6050h : vl slow down time

Index	6050h
Name	vl slow down time
Object Type	Variable
Data Type	UNSIGNED32
Read-Write Permission	RW
PDO MAPPING SETTING	No
Setting Range	UNSIGNED32
Factory setting	10000
Unit	ms

This object is the time spent when the motor drive decelerates from 6042h to 0 RPM under the Velocity Mode.

Object 6051h : vl quick stop time

Index	6051h
Name	vl quick stop time
Object Type	Variable
Data Type	UNSIGNED32
Read-Write Permission	RW
PDO MAPPING SETTING	No
Setting Range	Motor drive parameter 01-45 Pr.01-45=0 · Setting Range : 10~600000 Pr.01-45=1 · Setting Range : 100~6000000
Factory setting	1000
Unit	ms

This object is at velocity mode. It's the time required for decelerating from 6402h to 0 RPM.

Object 605Ah : Quick stop option code

Index	605Ah
Name	Quick stop option code
Object Type	Variable
Data Type	INTEGER16
Read-Write Permission	RW
PDO MAPPING SETTING	No
Setting Range	0: Disable motor drive function 1: Decelerate to stop by slow down ramp then Switch on Disabled (cannot be back to OP) 2: Decelerate to stop by quick stop ramp then Switch on Disabled (cannot be back to OP) 5: Decelerate to stop by slow down ramp and keep on Quick Stop status (can be back to OP) 6: Decelerate to stop by quick stop ramp and keep on Quick Stop status (can be back to OP)
Factory Setting	2

This object is a choice behavior when 6040h (Controlword) triggers Quick Stop bit.

Object 605Ch : Disable operation option code

Index	605Ch
Name	Disable operation option code
Object Type	Variable
Data Type	INTEGER16
Read-Write Permission	RW
PDO MAPPING SETTING	No
Setting Range	0: Disable motor drive 1: Decelerate to stop; disable motor drive
Factory Setting	1

This object is a choice behavior of the motor drive when the status switches from Operation Enable to Switched On.

Object 6060h : Modes of operation

Index	6060h
Name	Modes of operation
Object Type	Variable
Data Type	INTEGER8
Read-Write Permission	RW
PDO MAPPING SETTING	Yes
Setting Range	UNSIGNED32
Factory Setting	8

This object is to set up the operation mode. The operation modes are as follows:

Setting Value	Operation Mode
0	Reserve
1	Profile Position Mode
2	Velocity Mode
3	Reserve
4	Profile Torque Mode
5	Reserve
6	Homing Mode
7	Interpolated Position Mode
8	Cyclic Synchronous Position Mode
9	Reserve
10	Cyclic Synchronous Torque Mode

Object 6061h : Modes of operation display

Index	6061h
Name	Modes of operation display
Object Type	Variable
Data Type	INTEGER8
Read-Write Permission	RO
PDO MAPPING SETTING	Yes
Setting Range	INTEGER8
Factory Setting	0

This object shows the current operation mode.

Object 6502h : Supported drive modes

Index	6502h
Name	Supported drive modes
Object Type	Variable
Data Type	UNSIGNED32
Read-Write Permission	RO
PDO MAPPING SETTING	No
Setting Range	UNSIGNED32