

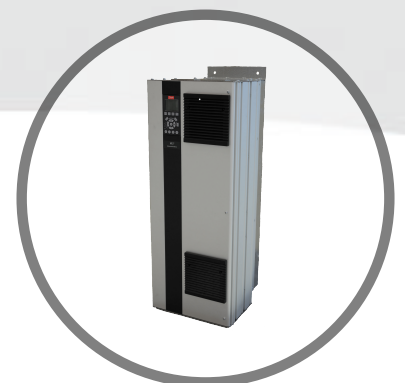

Operating Instructions

VLT[®] HVAC Drive FC 102

110-400 kW



Contents

1 Introduction	4
1.1 Product Overview	4
1.1.1 Interior Views	4
1.1.2 Extended Options Cabinets	5
1.2 Purpose of the Manual	6
1.3 Additional Resources	6
1.4 Product Overview	6
1.5 Internal Controller Functions	7
1.6 Frame Sizes and Power Ratings	7
2 Safety	8
2.1 Safety	8
3 Installation	9
3.1 Planning the Installation Site	9
3.2 Pre-Installation Check List	9
3.3 Mechanical Installation	9
3.3.1 Cooling	9
3.3.2 Lifting	10
3.3.3 Wall Mounting - IP21 (NEMA 1) and IP54 (NEMA 12) Units	10
3.4 Electrical Installation	11
3.4.1 General Requirements	11
3.4.2 Grounding Requirements	14
3.4.2.1 Leakage Current (>3.5 mA)	14
3.4.2.2 Grounding IP20 Enclosures	15
3.4.2.3 Grounding IP21/54 Enclosures	15
3.4.3 Motor Connection	16
3.4.3.1 Terminal Locations: D1h-D4h	16
3.4.3.2 Terminal Locations: D5h-D8h	20
3.4.4 Motor Cable	30
3.4.5 Motor Rotation Check	30
3.4.6 AC Mains Connection	30
3.5 Control Wiring Connection	30
3.5.1 Access	31
3.5.2 Using Screened Control Cables	31
3.5.3 Grounding of Screened Control Cables	31
3.5.4 Control Terminal Types	32
3.5.5 Wiring to Control Terminals	33
3.5.6 Control Terminal Functions	33
3.6 Serial Communication	33

3.7 Optional Equipment	34
3.7.1 Load Share Terminals	34
3.7.2 Regeneration Terminals	34
3.7.3 Anti-condensation Heater	34
3.7.4 Brake Chopper	34
3.7.5 Mains Shield	34
3.7.6 Mains Disconnect	34
3.7.7 Contactor	35
3.7.8 Circuit Breaker	35
4 Start Up and Commissioning	36
4.1 Pre-start	36
4.2 Applying Power	37
4.3 Basic Operational Programming	37
4.4 Local-control Test	38
4.5 System Start Up	39
5 User Interface	40
5.1 Local Control Panel	40
5.1.1 LCP Layout	40
5.1.2 Setting LCP Display Values	41
5.1.3 Display Menu Keys	41
5.1.4 Navigation Keys	42
5.1.5 Operation Keys	42
5.2 Back Up and Copying Parameter Settings	42
5.2.1 Uploading Data to the LCP	43
5.2.2 Downloading Data from the LCP	43
5.3 Restoring Default Settings	43
5.3.1 Recommended Initialisation	43
5.3.2 Manual Initialisation	43
6 Programming	44
6.1 Introduction	44
6.2 Programming Example	44
6.3 Control Terminal Programming Examples	46
6.4 International/North American Default Parameter Settings	46
6.5 Parameter Menu Structure	47
6.6 Remote Programming with MCT 10 Set-up Software	52
7 Application Examples	53
7.1 Introduction	53
7.2 Application Examples	53

7.3 Connection Examples for Control of Motor with External Signal Provider	58
7.3.1 Start/Stop	58
7.3.2 Pulse Start/Stop	58
7.3.3 Speed Up/Down	58
7.3.4 Potentiometer Reference	59
8 Status Messages	60
8.1 Status Display	60
8.2 Status Message Definitions Table	60
9 Warnings and Alarms	63
9.1 System Monitoring	63
9.2 Warning and Alarm Types	63
9.2.1 Warnings	63
9.2.2 Alarm Trip	63
9.2.3 Alarm Trip-lock	63
9.3 Warning and Alarm Displays	63
9.4 Warning and Alarm Definitions	64
9.5 Fault Messages	66
10 Basic Troubleshooting	73
11 Specifications	76
11.1 Power-dependent Specifications	76
11.2 General Technical Data	79
11.3 Fuse Tables	83
11.3.1 Protection	83
11.3.2 Fuse Selection	83
11.3.3 Short Circuit Current Rating (SCCR)	84
11.3.4 Connection Tightening Torques	84
Index	86

1

1 Introduction

1.1 Product Overview

1.1.1 Interior Views

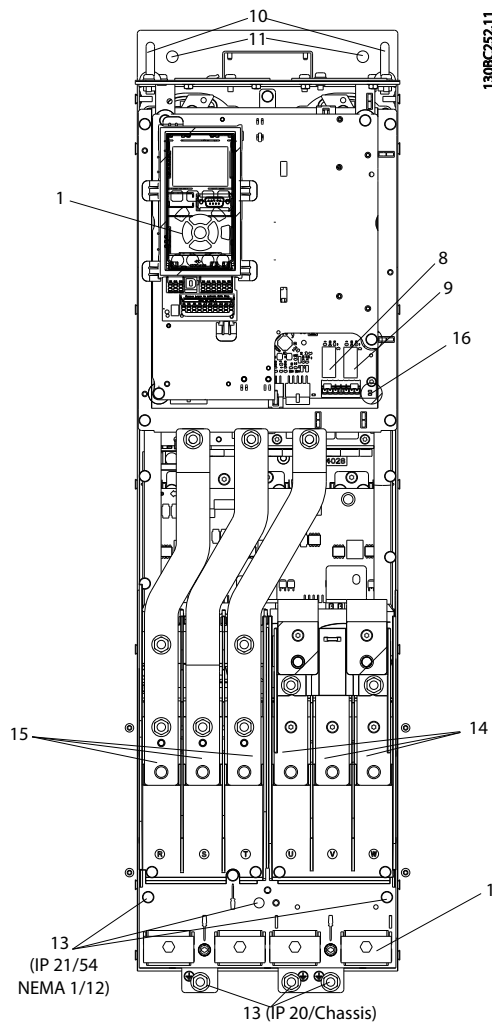

Illustration 1.1 D1 Interior Components

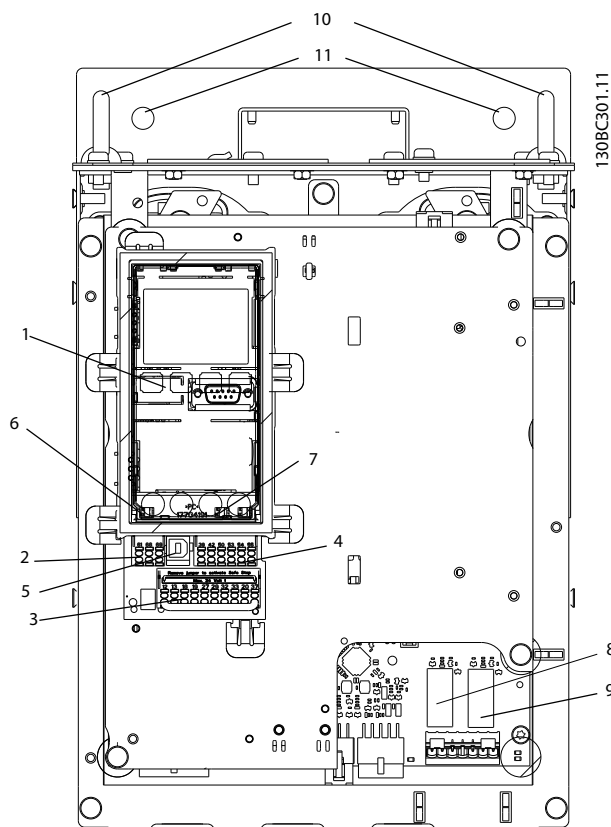

Illustration 1.2 Close-up View: LCP and Control Functions

1	LCP (Local Control Panel)	9	Relay 2 (04, 05, 06)
2	RS-485 serial bus connector	10	Lifting ring
3	Digital I/O and 24 V power supply	11	Mounting slot
4	Analog I/O connector	12	Cable clamp (PE)
5	USB connector	13	Earth (ground)
6	Serial bus terminal switch	14	Motor output terminals 96 (U), 97 (V), 98 (W)
7	Analog switches (A53), (A54)	15	Mains input terminals 91 (L1), 92 (L2), 93 (L3)
8	Relay 1 (01, 02, 03)	16	TB5 (IP21/54 only). Terminal block for anti-condensation heater

Table 1.1 Legend to *Illustration 1.1* and *Illustration 1.2*

NOTICE

For location of TB6 (terminal block for contactor), see *chapter 3.4.3.2 Terminal Locations: D5h-D8h*.

1.1.2 Extended Options Cabinets

If a frequency converter is ordered with one of the following options, it is supplied with an options cabinet that makes it taller.

- Brake chopper
- Mains disconnect
- Contactor
- Mains disconnect with contactor
- Circuit breaker

Illustration 1.3 shows an example of a frequency converter with an options cabinet. Table 1.2 lists the variants for the frequency converters that include input options.

Options unit designations	Extension cabinets	Possible options
D5h	D1h enclosure with short extension	Brake, Disconnect
D6h	D1h enclosure with tall extension	Contactor, Contactor with Disconnect, Circuit Breaker
D7h	D2h enclosure with short extension	Brake, Disconnect
D8h	D2h enclosure with tall extension	Contactor, Contactor with Disconnect, Circuit Breaker

Table 1.2 Overview of Extended Options

The D7h and D8h frequency converters (D2h plus options cabinet), include a 200 mm pedestal for floor mounting.

There is a safety latch on the front cover of the options cabinet. If the frequency converter is supplied with a mains disconnect or circuit breaker, the safety latch prevents the cabinet door from being opened while the frequency converter is energized. Before opening the door of the frequency converter, the disconnect or circuit breaker must be opened (to de-energize the frequency converter) and the cover of the options cabinet must be removed.

For frequency converters purchased with a disconnect, contactor or circuit breaker, the name plate label includes a type code for a replacement that does not include the option. If there is a problem with the frequency converter, it is replaced independent of the options.

Refer to *chapter 3.7 Optional Equipment* for more detailed descriptions of the input options and other options that may be added to the frequency converter.

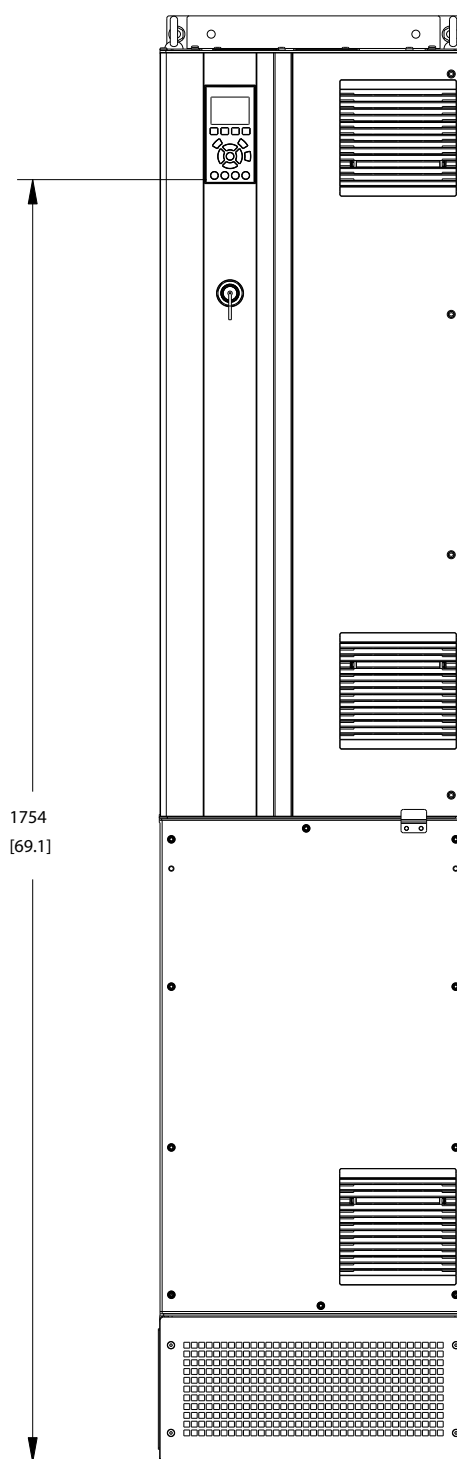

Illustration 1.3 D7h Enclosure

130BC539.10

1.2 Purpose of the Manual

This manual provides detailed information for the installation and start-up of the frequency converter.

Chapter 3 Installation provides requirements for mechanical and electrical installation, including:

- Input
- Motor
- Control wiring
- Serial communication wiring
- Control terminal functions

Chapter 4 Start Up and Commissioning provides detailed procedures for:

- Start-up
- Basic operational programming
- Functional testing

The remaining chapters provide supplementary details. These details include:

- User interface
- Detailed programming
- Application examples
- Start-up
- Troubleshooting
- Specifications

VLT® is a registered trademark.

1.3 Additional Resources

Other resources are available to understand advanced frequency converter functions and programming.

- The *VLT® Programming Guide* provides greater detail on working with parameters and many application examples.
- The *VLT® Design Guide* is intended to provide detailed capabilities and functionality to design motor control systems.
- Supplemental publications and manuals are available from Danfoss.
See www.danfoss.com/BusinessAreas/DrivesSolutions/Documentations/VLT+Technical+Documentation.htm for listings.
- Optional equipment is available that may change some of the procedures described. Reference the instructions supplied with those options for specific requirements. Contact the local Danfoss supplier or visit the Danfoss website:
www.danfoss.com/BusinessAreas/DrivesSolutions/

Documentations/VLT+Technical+Documentation.htm, for downloads or additional information.

1.4 Product Overview

A frequency converter is an electronic motor controller that converts DC into a variable AC waveform output. The frequency and voltage of the output are regulated to control the motor speed or torque. The frequency converter can vary the speed of the motor in response to system feedback, such as position sensors on a conveyor belt. The frequency converter can also regulate the motor by responding to remote commands from external controllers.

The frequency converter offers many control, monitoring and efficiency functions such as:

- Monitoring the system and motor status
- Issuing warnings or alarms for fault conditions
- Starting and stopping the motor
- Optimising energy efficiency

Operation and monitoring functions are available as status indications to an outside control system or serial communication network.

1.5 Internal Controller Functions

Illustration 1.4 is a block diagram of the frequency converter's internal components.

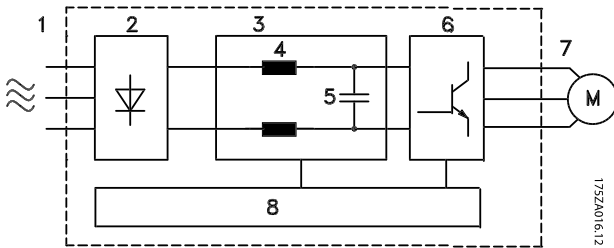

Illustration 1.4 Frequency Converter Block Diagram

Area	Title	Functions
1	Mains input	<ul style="list-style-type: none"> 3-phase AC mains supply to the frequency converter
2	Rectifier	<ul style="list-style-type: none"> The rectifier bridge converts the AC input to DC current to supply inverter power.
3	DC-bus	<ul style="list-style-type: none"> Intermediate DC-bus circuit handles the DC current.
4	DC reactors	<ul style="list-style-type: none"> Filter the intermediate DC circuit voltage. Provide line transient protection. Reduce RMS current. Raise the power factor reflected back to the line. Reduce harmonics on the AC input.

Area	Title	Functions
5	Capacitor bank	<ul style="list-style-type: none"> Stores the DC power. Provides ride-through protection for short power losses.
6	Inverter	<ul style="list-style-type: none"> Converts the DC into a controlled PWM AC waveform for a controlled variable output to the motor.
7	Output to motor	<ul style="list-style-type: none"> Regulated 3-phase output power to the motor
8	Control circuitry	<ul style="list-style-type: none"> Input power, internal processing, output, and motor current are monitored to provide efficient operation and control. User interface and external commands are monitored and performed. Status output and control can be provided.

Table 1.3 Legend to Illustration 1.4

1.6 Frame Sizes and Power Ratings

kW High Overload	75	90	110	132	160	200	250	315	315
kW Normal Overload	90	110	132	160	200	250	315	355	400
400 V		D3h	D3h	D3h	D4h	D4h	D4h		
500 V			D3h	D3h	D3h	D4h	D4h	D4h	
525 V	D3h	D3h	D3h	D4h	D4h	D4h	D4h		
690 V		D3h	D3h	D3h	D4h	D4h	D4h		D4h

Table 1.4 kW Rated Frequency Converters

HP High Overload	100	125	150	200	250	300	350	350
HP Normal Overload	125	150	200	250	300	350	400	450
460 V		D3h	D3h	D3h	D4h	D4h		D4h
575 V	D3h	D3h	D3h	D4h	D4h	D4h	D4h	

Table 1.5 HP Rated Frequency Converters

2 Safety

2.1 Safety

⚠ WARNING

HIGH VOLTAGE

Frequency converters contain high voltage when connected to AC mains input power. Qualified personnel only should perform installation, start up, and maintenance. Failure to perform installation, start up, and maintenance by qualified personnel could result in death or serious injury.

⚠ WARNING

UNINTENDED START

When the frequency converter is connected to AC mains, the motor may start at any time. The frequency converter, motor, and any driven equipment must be in operational readiness. Failure to be in operational readiness when the frequency converter is connected to AC mains could result in death, serious injury, equipment, or property damage.

⚠ WARNING

DISCHARGE TIME

Frequency converters contain DC-link capacitors that can remain charged even when the frequency converter is not powered. To avoid electrical hazards, disconnect AC mains, any permanent magnet type motors, and any remote DC-link power supplies, including battery back-ups, UPS, and DC-link connections to other frequency converters. Wait for the capacitors to fully discharge before performing any service or repair work. The amount of wait time is listed in the *Discharge Time* table. Failure to wait the specified time after power has been removed before doing service or repair could result in death or serious injury.

Voltage [V]	Power range [kW]	Minimum waiting time (minutes)
3x400	90-250	20
3x400	110-315	20
3x500	110-315	20
3x500	132-355	20
3x525	75-250	20
3x525	90-315	20
3x690	90-250	20
3x690	110-315	20

Table 2.1 Discharge Time



Table 2.2 Approvals

The frequency converter complies with UL508C thermal memory retention requirements. For more information, refer to the section *Motor Thermal Protection* in the product specific *design guide*.

NOTICE

Imposed limitations on the output frequency (due to export control regulations):

From software version 6.72 onwards, the output frequency of the frequency converter is limited to 590 Hz. Software versions 6x.xx also limit the maximum output frequency to 590 Hz, but these versions cannot be flashed, that is, neither downgraded nor upgraded.

3 Installation

3.1 Planning the Installation Site

NOTICE

Before performing the installation it is important to plan the installation of the frequency converter. Neglecting this may result in extra work during and after installation.

Select the best possible operation site by considering the following (see details on the following pages and the respective Design Guides):

- Ambient operating temperature
- Installation method
- How to cool the unit
- Position of the frequency converter
- Cable routing
- Ensure the power source supplies the correct voltage and necessary current
- Ensure that the motor current rating is within the maximum current from the frequency converter
- If the frequency converter is without built-in fuses, ensure that the external fuses are rated correctly

Voltage [V]	Altitude restrictions
380-500	At altitudes above 3,000 m, contact Danfoss regarding PELV
525-690	At altitudes above 2,000 m, contact Danfoss regarding PELV

Table 3.1 Installation in High Altitudes

3.2 Pre-Installation Check List

- Before unpacking the frequency converter, ensure that the packaging is intact. If any damage has occurred, immediately contact the shipping company to claim the damage.
- Unpack the frequency converter as close as possible to the final installation site.
- Ensure the model number number on the nameplate corresponds to the model number on the order.
- Ensure that each of the following are rated for the same voltage:
 - Mains (power)
 - Frequency converter
 - Motor

- Ensure that the frequency converter output current rating is equal to or greater than the motor full load current for peak motor performance.
 - Motor size and frequency converter power must match for proper overload protection.
 - If frequency converter rating is less than motor, full motor output cannot be achieved.

3.3 Mechanical Installation

3.3.1 Cooling

- Top and bottom clearance for air cooling must be provided. Generally, 225 mm (9 in) is required.
- Improper mounting can result in over heating and reduced performance
- Derating for temperatures starting between 45 °C (113 °F) and 50 °C (122 °F) and elevation 1,000 m (3,300 ft) above sea level must be considered. See *VLT® HVAC Drive FC 102VLT® AQUA Drive FC 202 Design Guide* for detailed information.

The high-power frequency converters utilise a back-channel cooling concept that removes heatsink cooling air, which carries approximately 90% of the heat out of the back channel of the frequency converters. The back-channel air can be redirected from the panel or room using one of the kits below.

Duct cooling

A back-channel cooling kit is available to direct the heat sink cooling air out of the panel when an IP20/chassis frequency converters is installed in a Rittal enclosure. Use of this kit reduces the heat in the panel and smaller door fans can be specified on the enclosure.

Cooling out the back (top and bottom covers)

The back-channel cooling air can be ventilated out of the room so that the heat from the back channel is not dissipated into the control room.

NOTICE

A door fan(s) is required on the enclosure to remove the heat not contained in the backchannel of the frequency converters and any additional losses generated by other components inside the enclosure. The total required air flow must be calculated so that the appropriate fans can be selected.

Airflow

The necessary airflow over the heat sink must be secured. The flow rate is shown in *Table 3.2*.

NOTICE

The fan runs for the following reasons:

- AMA
- DC Hold
- Pre-Mag
- DC Brake
- 60% of nominal current is exceeded
- Specific heat sink temperature exceeded (power size dependent)
- Specific power card ambient temperature exceeded (power size dependent)
- Specific control card ambient temperature exceeded

Frame	Door fan/top fan	Heat sink fan
D1h/D3h	102 m ³ /hr (60 CFM)	420 m ³ /hr (250 CFM)
D2h/D4h	204 m ³ /hr (120 CFM)	840 m ³ /hr (500 CFM)

Table 3.2 Airflow

3.3.2 Lifting

Always lift the frequency converter using the dedicated lifting eyes. Use a bar to avoid bending the lifting holes.

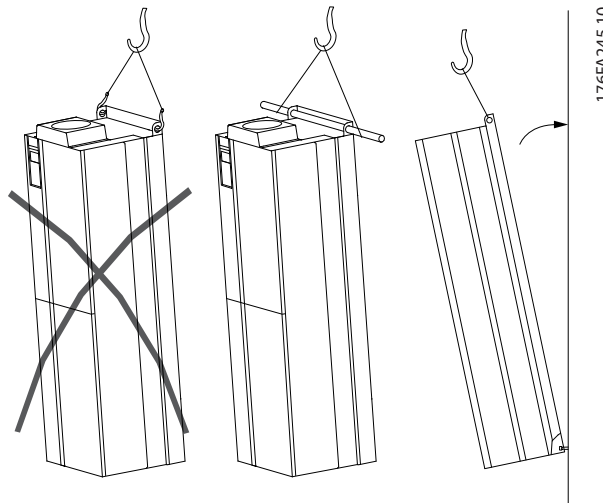

Illustration 3.1 Recommended Lifting Method

WARNING

RISK OF INJURY OR DEATH

The lifting bar must be able to handle the weight of the frequency converter to ensure that it will not break during lifting.

- See *chapter 11.1 Power-dependent Specifications* for the weight of the different enclosure types.
- Maximum diameter for bar is 2.5 cm (1 inch).
- The angle from the top of the frequency converter to the lifting cable should be 60° or greater.

Failure to follow recommendations could result in death or serious injury.

3.3.3 Wall Mounting - IP21 (NEMA 1) and IP54 (NEMA 12) Units

Consider the following before selecting the final installation site:

- Free space for cooling
- Access to open the door
- Cable entry from the bottom

3.4 Electrical Installation

3.4.1 General Requirements

This section contains detailed instructions for wiring the frequency converter. The following tasks are described:

- Wiring the motor to the frequency converter output terminals
- Wiring the AC mains to the frequency converter input terminals
- Connecting control and serial communication wiring
- After power has been applied, checking input and motor power; programming control terminals for their intended functions

⚠ WARNING

EQUIPMENT HAZARD!

Rotating shafts and electrical equipment can be hazardous. All electrical work must conform to national and local electrical codes. It is strongly recommended that installation, start up, and maintenance be performed only by trained and qualified personnel. Failure to follow these guidelines could result in death or serious injury.

⚠ CAUTION

WIRING ISOLATION!

Run input power, motor wiring and control wiring in three separate metallic conduits or use separated shielded cable for high frequency noise isolation. Failure to isolate power, motor and control wiring could result in less than optimum frequency converter and associated equipment performance.

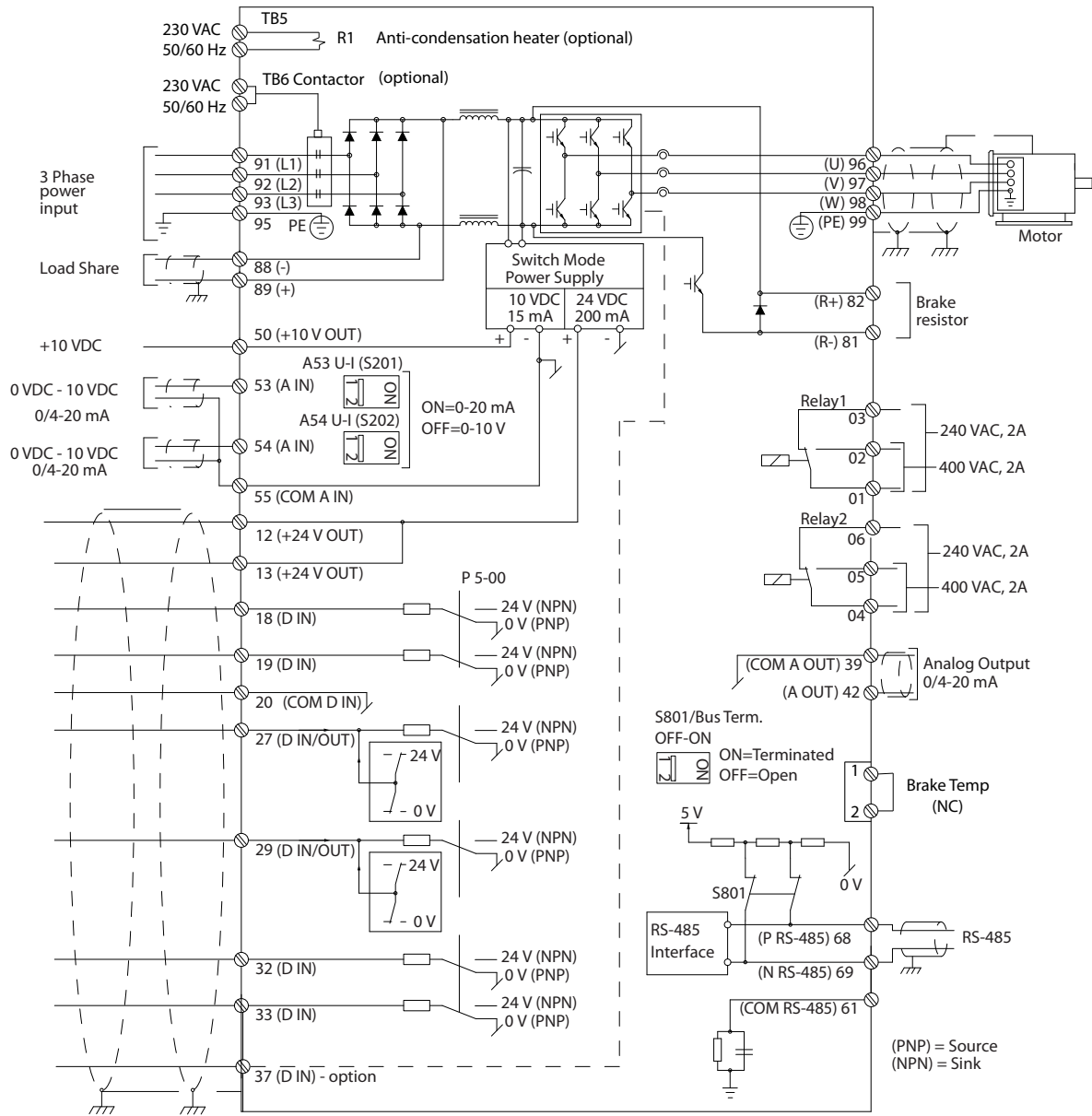

130BC548.12

Illustration 3.2 Interconnect Diagram

A=Analog, D=Digital

*Terminal 37 (optional) is used for Safe Torque Off. For Safe Torque Off installation instructions, refer to the *Safe Torque Off Operating Instructions for Danfoss VLT® Frequency Converters*.

**Do not connect cable screen.

For safety, comply with the following requirements

- Electronic controls equipment is connected to hazardous mains voltage. Extreme care should be taken to protect against electrical hazards when applying power to the unit.
- Run motor cables from multiple frequency converters separately. Induced voltage from output motor cables run together can charge equipment capacitors even with the equipment turned off and locked out.
- Field wiring terminals are not intended to receive a conductor one size larger.

Overload and Equipment Protection

- An electronically activated function within the frequency converter provides overload protection for the motor. The overload calculates the level of increase to activate timing for the trip (controller output stop) function. The higher the current draw, the quicker the trip response. The overload provides Class 20 motor protection. See *chapter 9 Warnings and Alarms* for details on the trip function.
- Because the motor wiring carries high frequency current, it is important that wiring for mains, motor power, and control are run separately. Use metallic conduit or separated shielded wire. See *Illustration 3.3*. Failure to isolate power, motor, and control wiring could result in less than optimum equipment performance.
- All frequency converters must be provided with short-circuit and over-current protection. Input fusing is required to provide this protection, see *Illustration 3.4*. If not factory supplied, fuses must be provided by the installer as part of installation. See maximum fuse ratings in *chapter 11.3.1 Protection*.

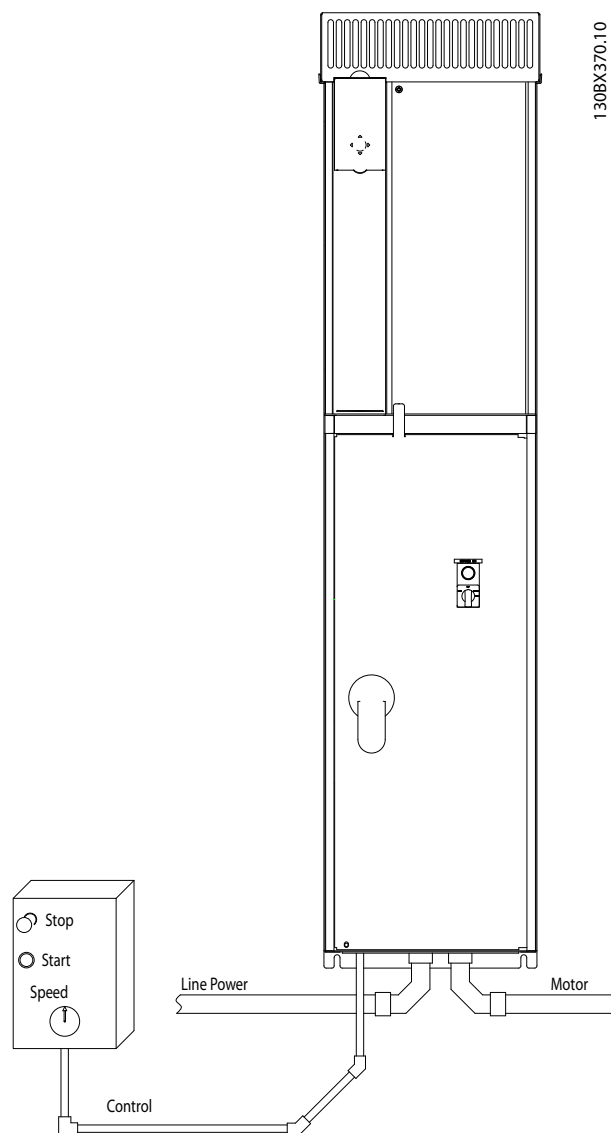
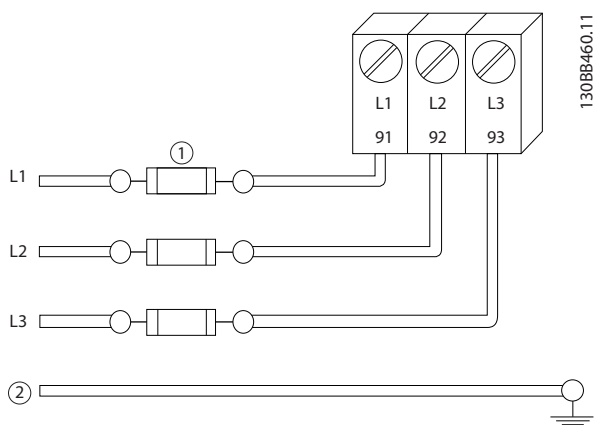

Illustration 3.3 Example of Proper Electrical Installation Using Conduit



Item #	Description
1	Fuses
2	Ground

Illustration 3.4 Frequency Converter Fuses

Wire Type and Ratings

- All wiring must comply with local and national regulations regarding cross-section and ambient temperature requirements.
- Danfoss recommends that all power connections be made with a minimum 75 °C rated copper wire.

3.4.2 Grounding Requirements

WARNING

GROUNDING HAZARD!

For operator safety, it is important to ground the frequency converter properly in accordance with national and local electrical codes as well as instructions contained within this document. Do not use conduit connected to the frequency converter as a replacement for proper grounding. Ground currents are higher than 3.5 mA. Failure to ground the frequency converter properly could result in death or serious injury.

NOTICE

It is the responsibility of the user or certified electrical installer to ensure correct grounding of the equipment in accordance with national and local electrical codes and standards.

- Follow all local and national electrical codes to ground electrical equipment properly
- Proper protective earthing for equipment with ground currents higher than 3.5 mA must be

established, see chapter 3.4.2.1 Leakage Current (>3.5 mA)

- A dedicated ground wire is required for input power, motor power and control wiring
- Use the clamps provided with the equipment for proper ground connections
- Do not ground one frequency converter to another in a “daisy chain” fashion
- Keep the ground wire connections as short as possible
- Using high-strand wire to reduce electrical noise is recommended
- Follow motor manufacturer wiring requirements

3.4.2.1 Leakage Current (>3.5 mA)

Follow national and local codes regarding protective earthing of equipment with a leakage current >3.5 mA. Frequency converter technology implies high frequency switching at high power. This will generate a leakage current in the earth connection. A fault current in the frequency converter at the output power terminals might contain a DC component, which can charge the filter capacitors and cause a transient earth current. The earth leakage current depends on various system configurations including RFI filtering, screened motor cables, and frequency converter power.

EN/IEC61800-5-1 (Power Drive System Product Standard) requires special care if the leakage current exceeds 3.5 mA. Earthing (grounding) must be reinforced in one of the following ways:

- Earth (ground) wire of at least 10 mm²
- Two separate earth (ground) wires both complying with the dimensioning rules

See EN 60364-5-54 § 543.7 for further information.

3.4.2.2 Grounding IP20 Enclosures

The frequency converter can be grounded using conduit or shielded cable. For grounding of the power connections, use the dedicated grounding points as shown in *Illustration 3.5*.

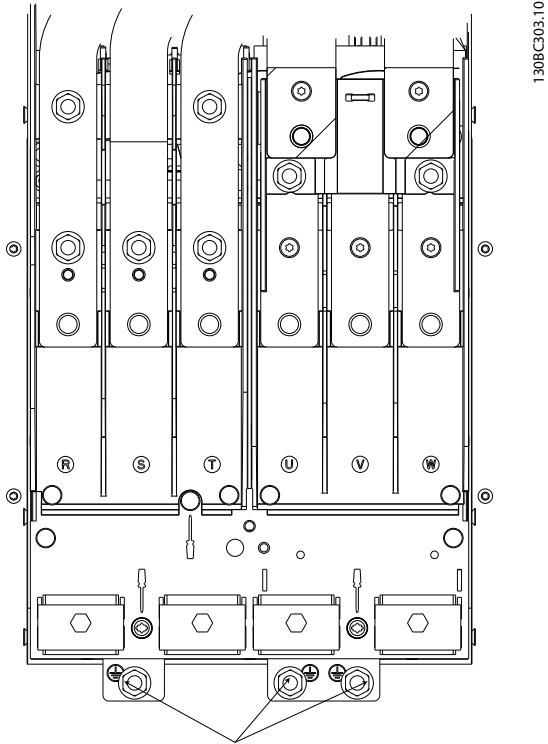

Illustration 3.5 Grounding Points for IP20 (Chassis) Enclosures

3.4.2.3 Grounding IP21/54 Enclosures

The frequency converter can be grounded using conduit or shielded cable. For grounding of the power connections, use the dedicated grounding points as shown in *Illustration 3.6*.

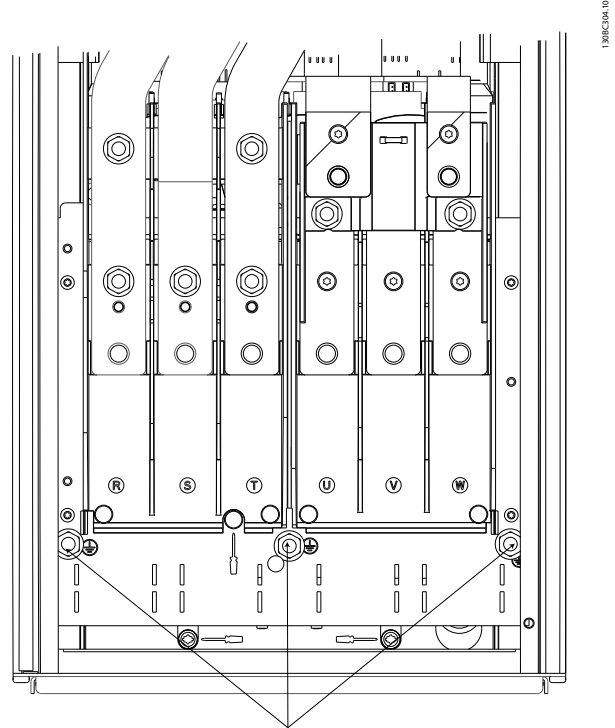

Illustration 3.6 Grounding for IP21/54 Enclosures.

3.4.3 Motor Connection

WARNING

INDUCED VOLTAGE!

Run output motor cables from multiple frequency converters separately. Induced voltage from output motor cables run together can charge equipment capacitors even with the equipment turned off and locked out. Failure to run output motor cables separately could result in death or serious injury.

- For maximum cable sizes, see *chapter 11.1 Power-dependent Specifications*
- Comply with local and national electrical codes for cable sizes

- Gland plates are provided at the base of IP21/54 and higher (NEMA1/12) units
- Do not install power factor correction capacitors between the frequency converter and the motor
- Do not wire a starting or pole-changing device between the frequency converter and the motor
- Connect the 3-phase motor wiring to terminals 96 (U), 97 (V), and 98 (W)
- Earth (ground) the cable in accordance with the instructions provided
- Torque terminals in accordance with the information provided in *chapter 11.3.4 Connection Tightening Torques*
- Follow motor manufacturer wiring requirements

3.4.3.1 Terminal Locations: D1h-D4h

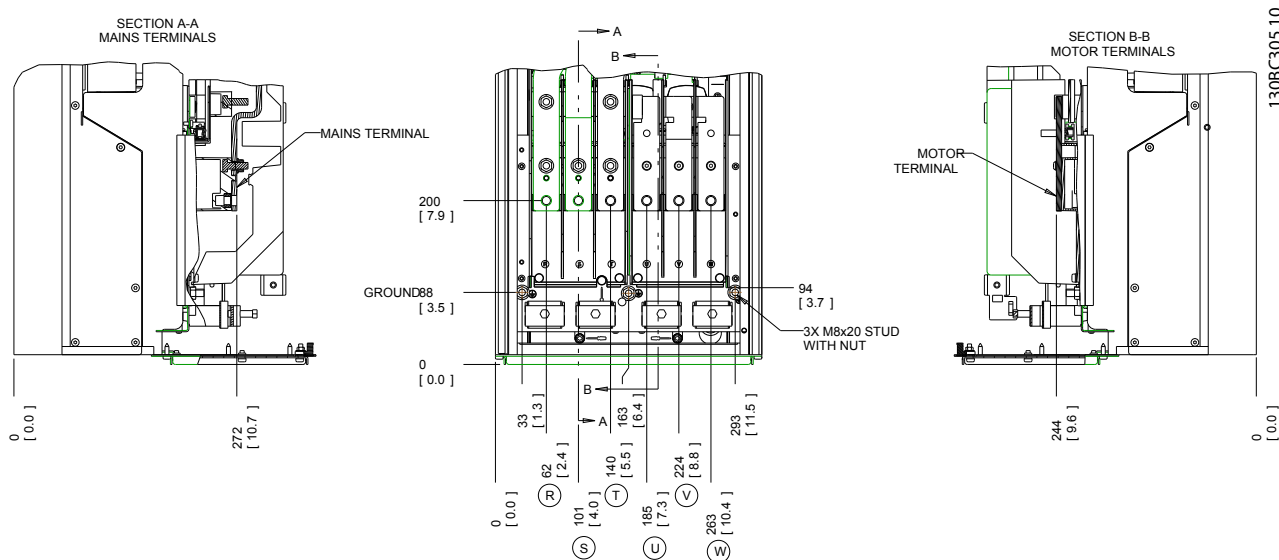

Illustration 3.7 Terminal Locations D1h

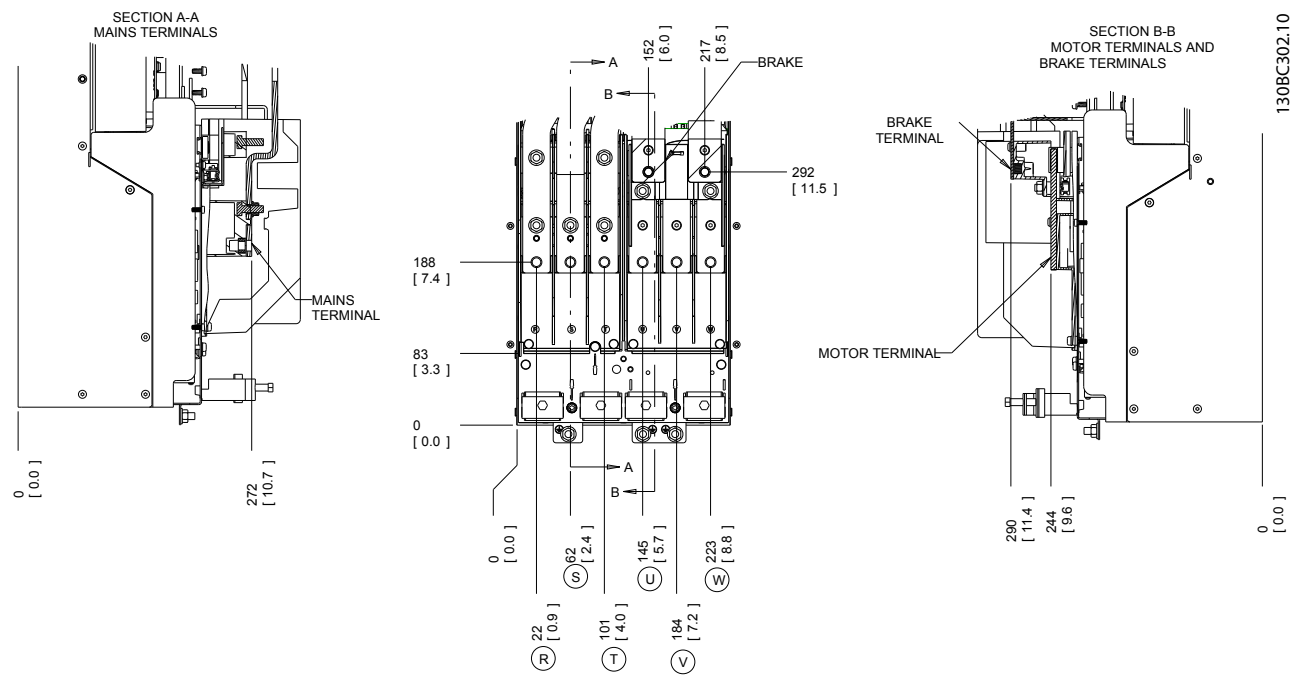
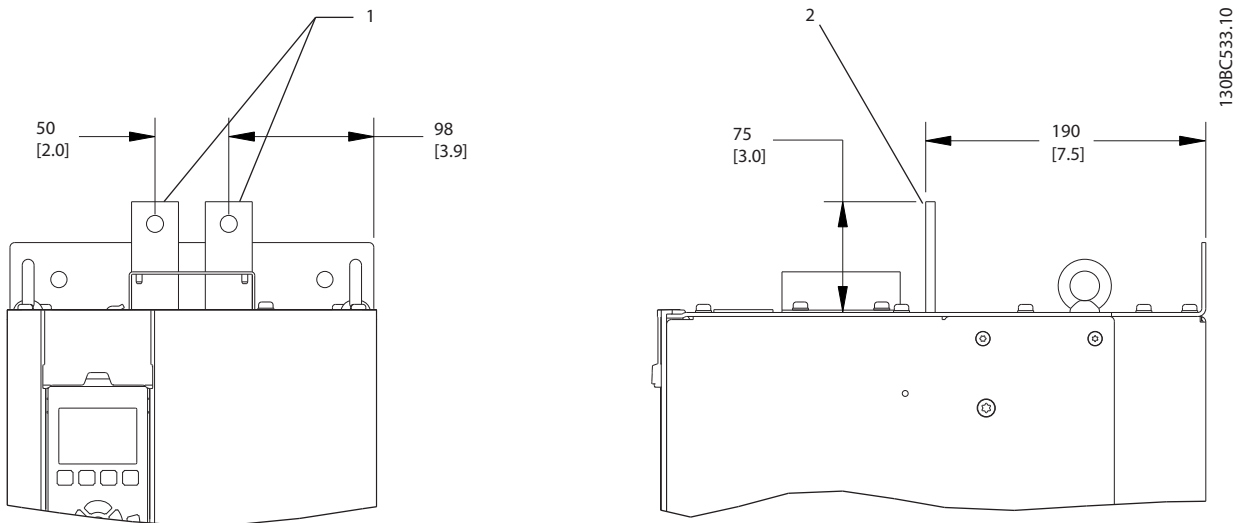

Illustration 3.8 Terminal Locations D3h



1	Front view
2	Side view

Illustration 3.9 Loadshare and Regeneration Terminals, D3h

3

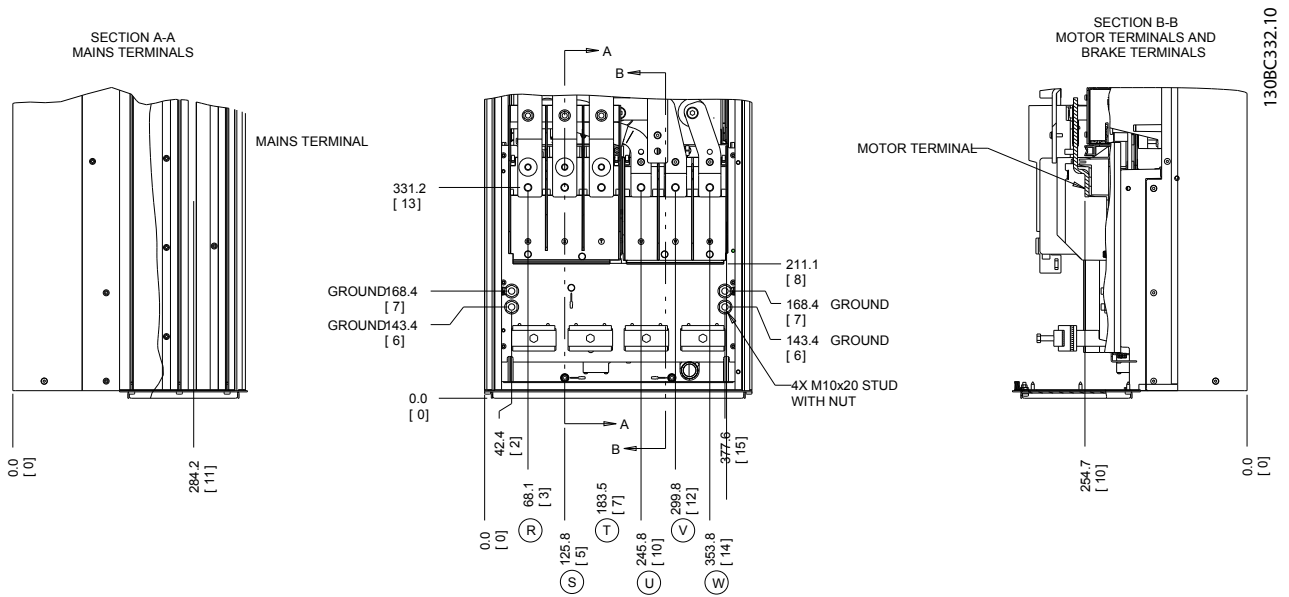

Illustration 3.10 Terminal Locations D2h

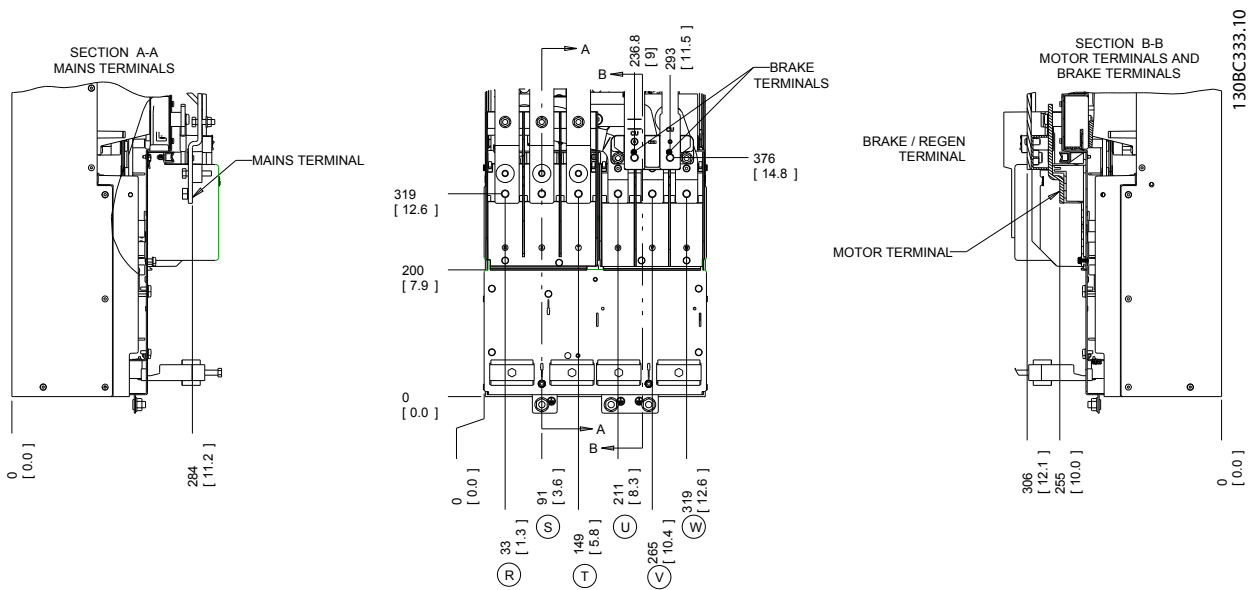
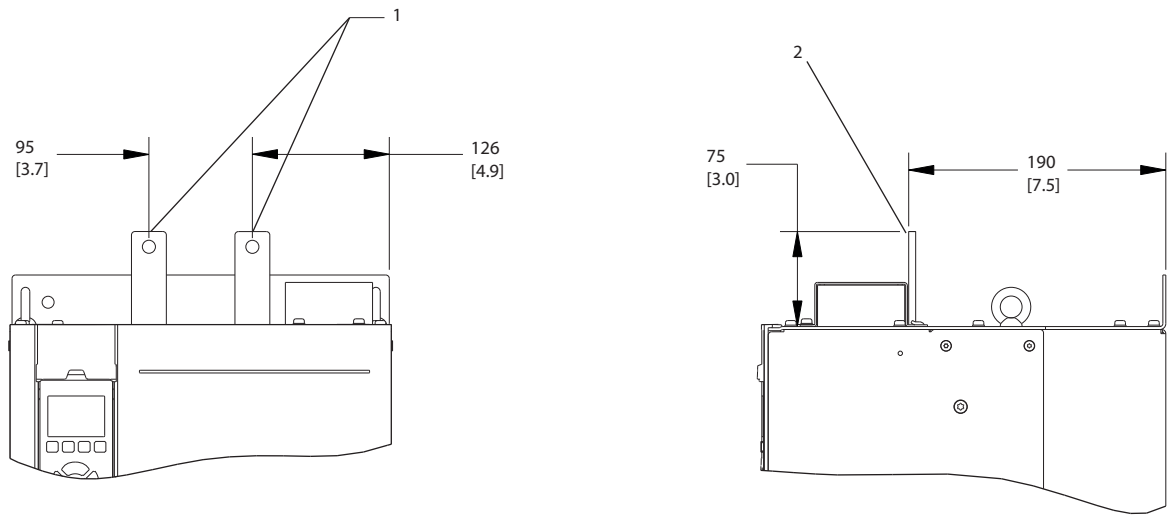

Illustration 3.11 Terminal Locations D4h



1308C534.10

3

1	Front view
2	Side view

Illustration 3.12 Load Share and Regeneration Terminals, D4h

3.4.3.2 Terminal Locations: D5h-D8h

3

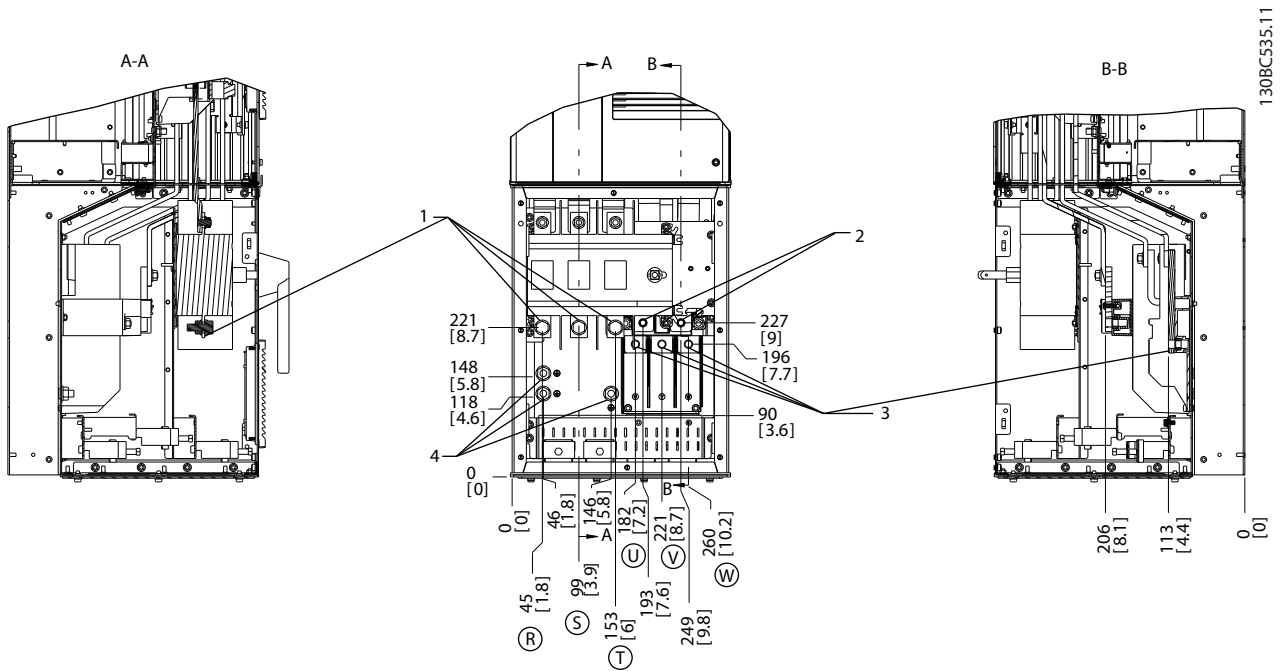

1	Mains Terminals
2	Brake Terminals
3	Motor Terminals
4	Earth/Ground Terminals

Illustration 3.13 Terminal Locations, D5h with Disconnect Option

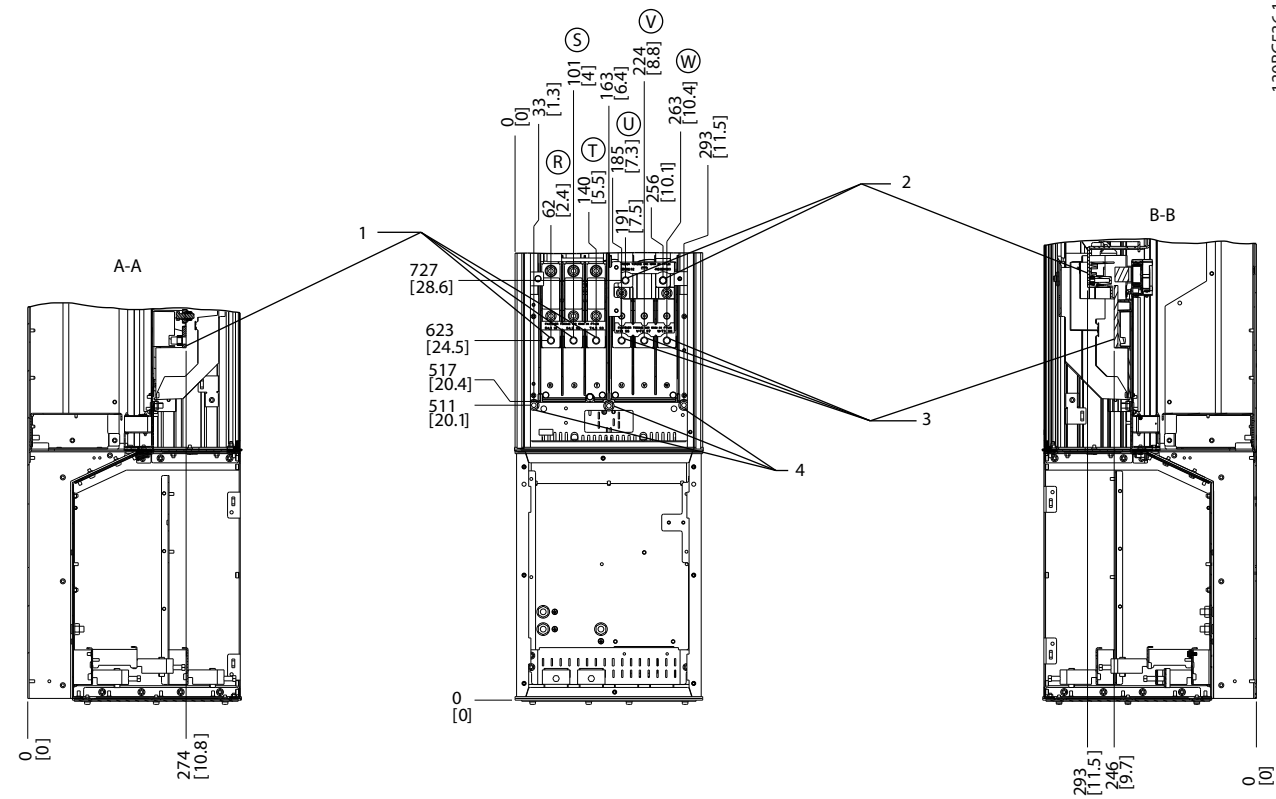

130BC536.11

3

1	Mains Terminals
2	Brake Terminals
3	Motor Terminals
4	Earth/Ground Terminals

Illustration 3.14 Terminal Locations, D5h with Brake Option

3

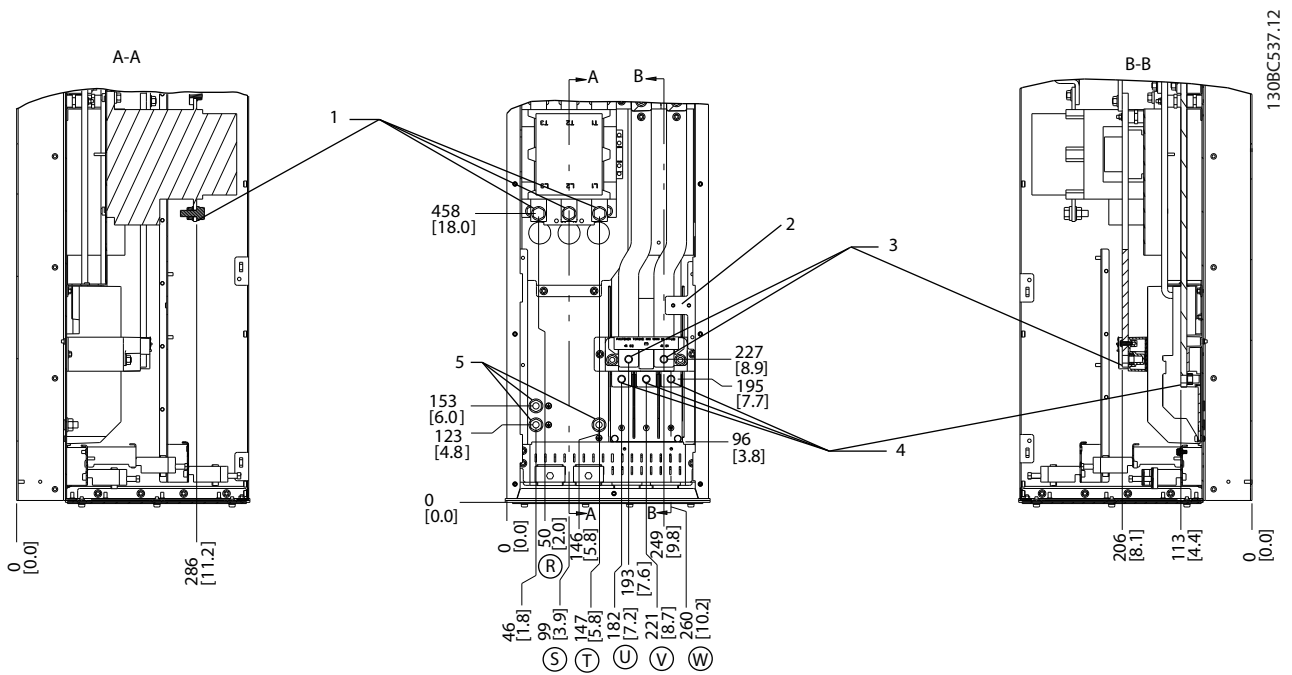

1	Mains Terminals
2	TB6 Terminal block for contactor
3	Brake Terminals
4	Motor Terminals
5	Earth/Ground Terminals

Illustration 3.15 Terminal Locations, D6h with Contactor Option

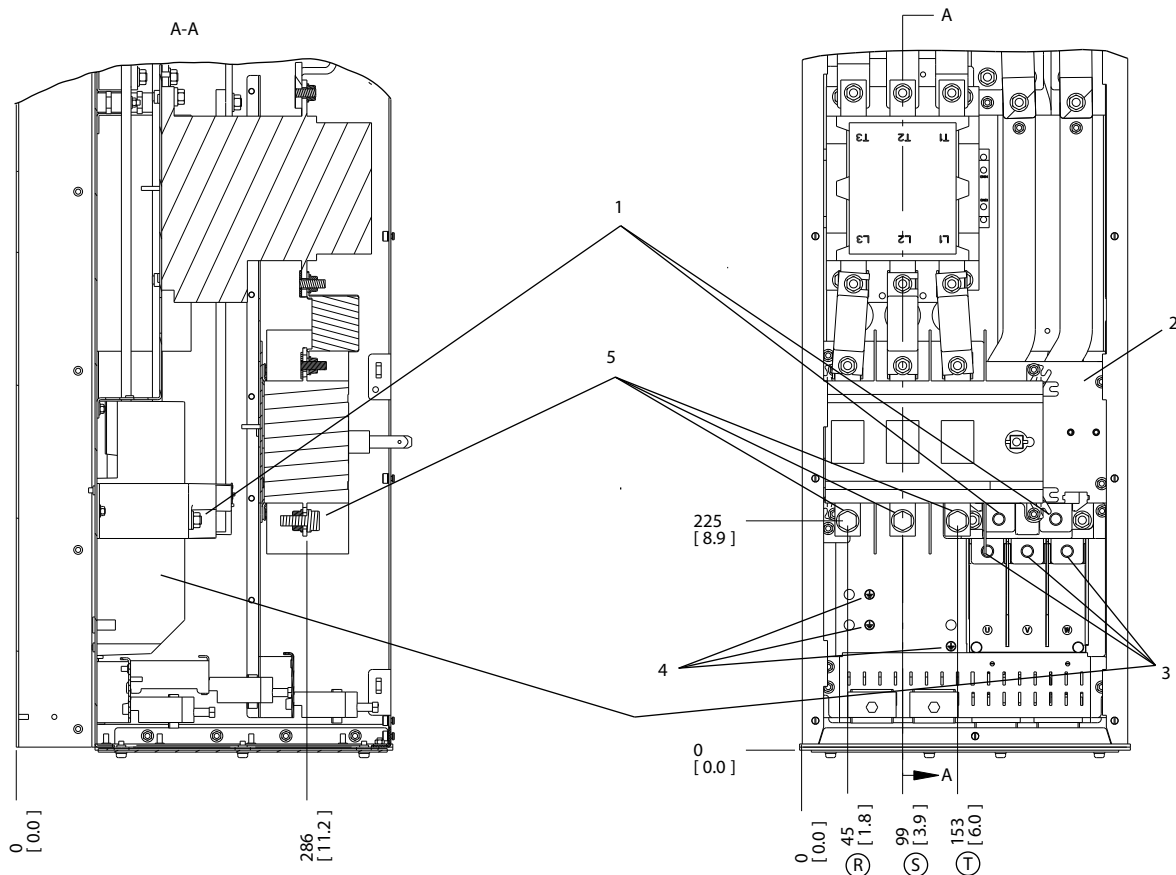

130BC538.12

3

1	Brake Terminals
2	TB6 Terminal block for contactor
3	Motor Terminals
4	Earth/Ground Terminals
5	Mains Terminals

Illustration 3.16 Terminal Locations, D6h with Contactor and Disconnect Options

3

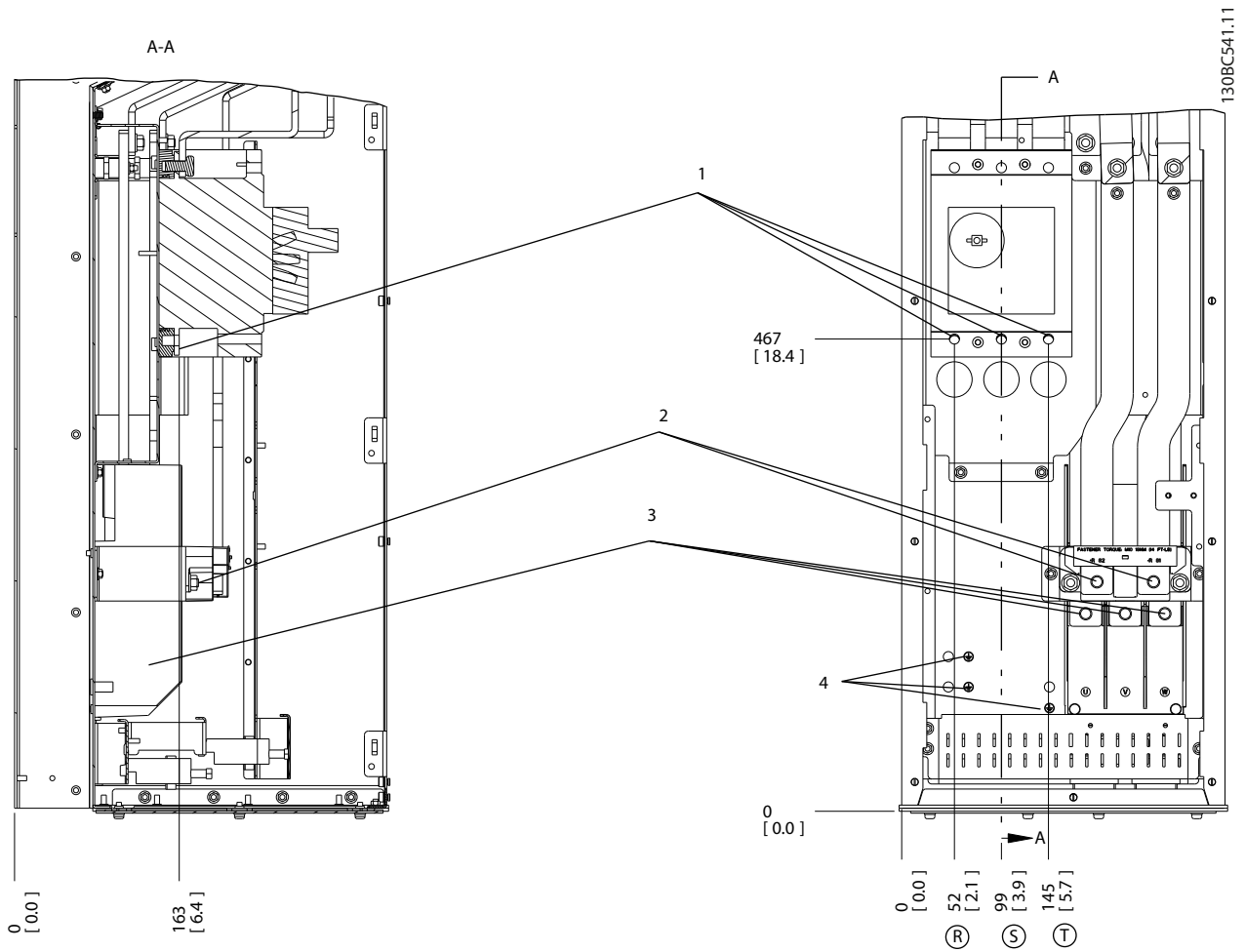

1	Mains Terminals
2	Brake Terminals
3	Motor Terminals
4	Earth/Ground Terminals

Illustration 3.17 Terminal Locations, D6h with Circuit Breaker Option

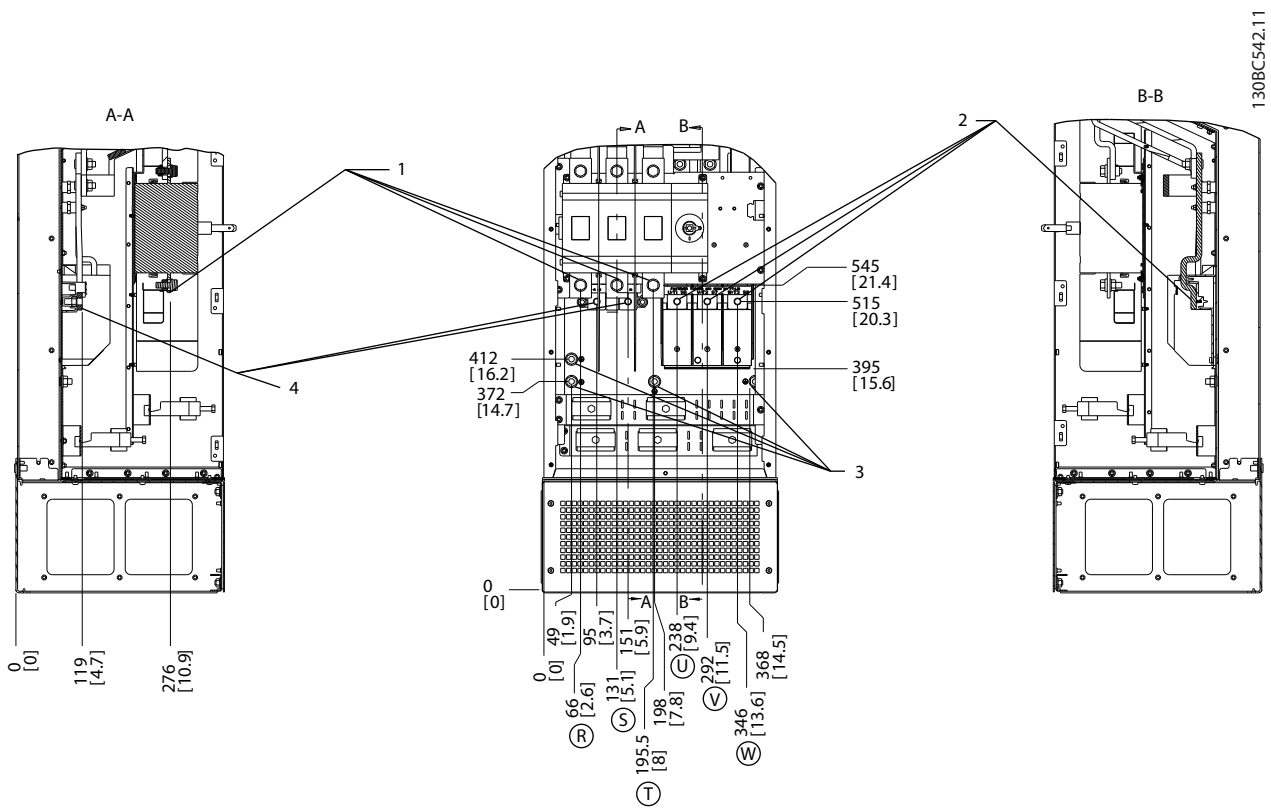

1308C542.11

3

1	Mains Terminals
2	Motor Terminals
3	Earth/Ground Terminals
4	Brake Terminals

Illustration 3.18 Terminal Locations, D7h with Disconnect Option

3

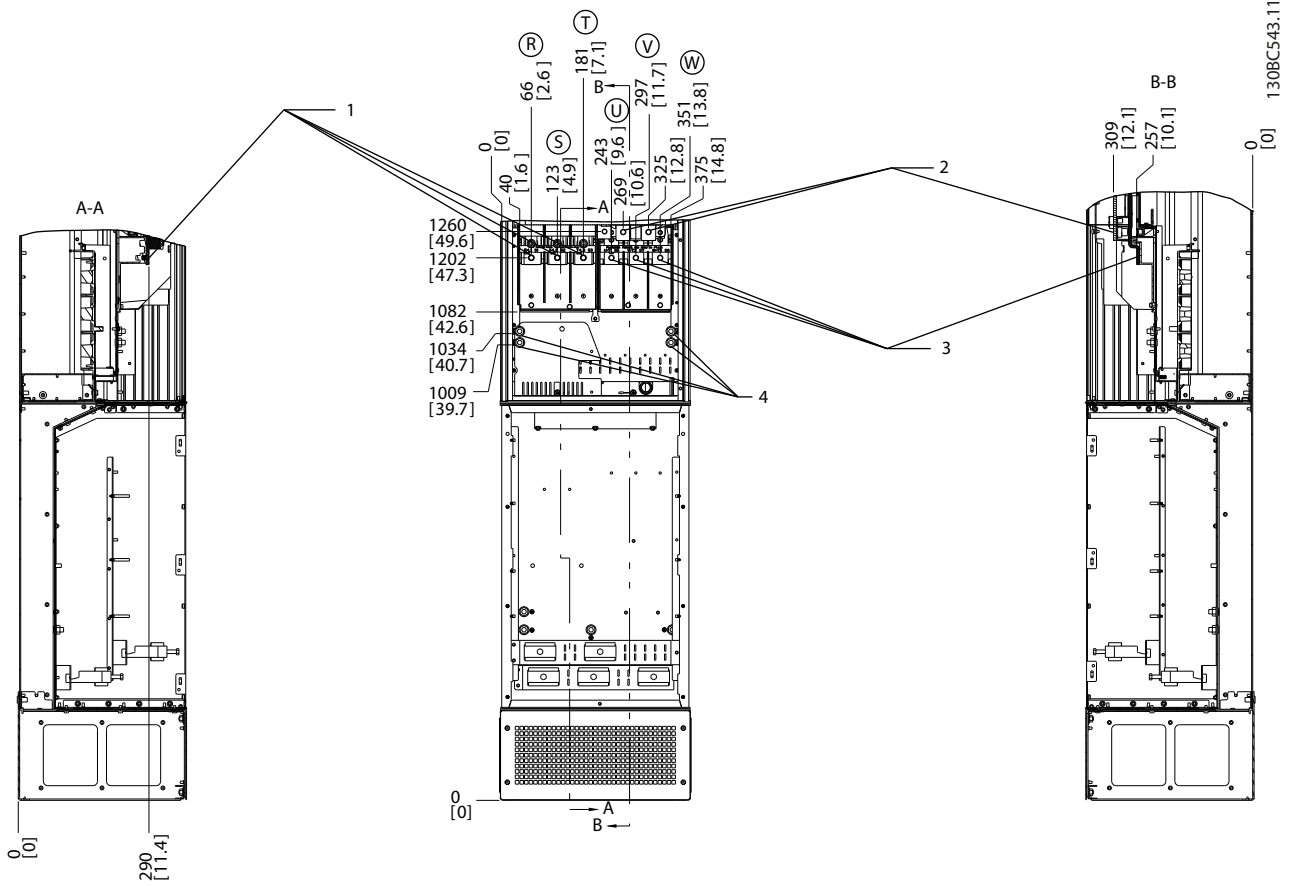

1	Mains Terminals
2	Brake Terminals
3	Motor Terminals
4	Earth/Ground Terminals

Illustration 3.19 Terminal Locations, D7h with Brake Option

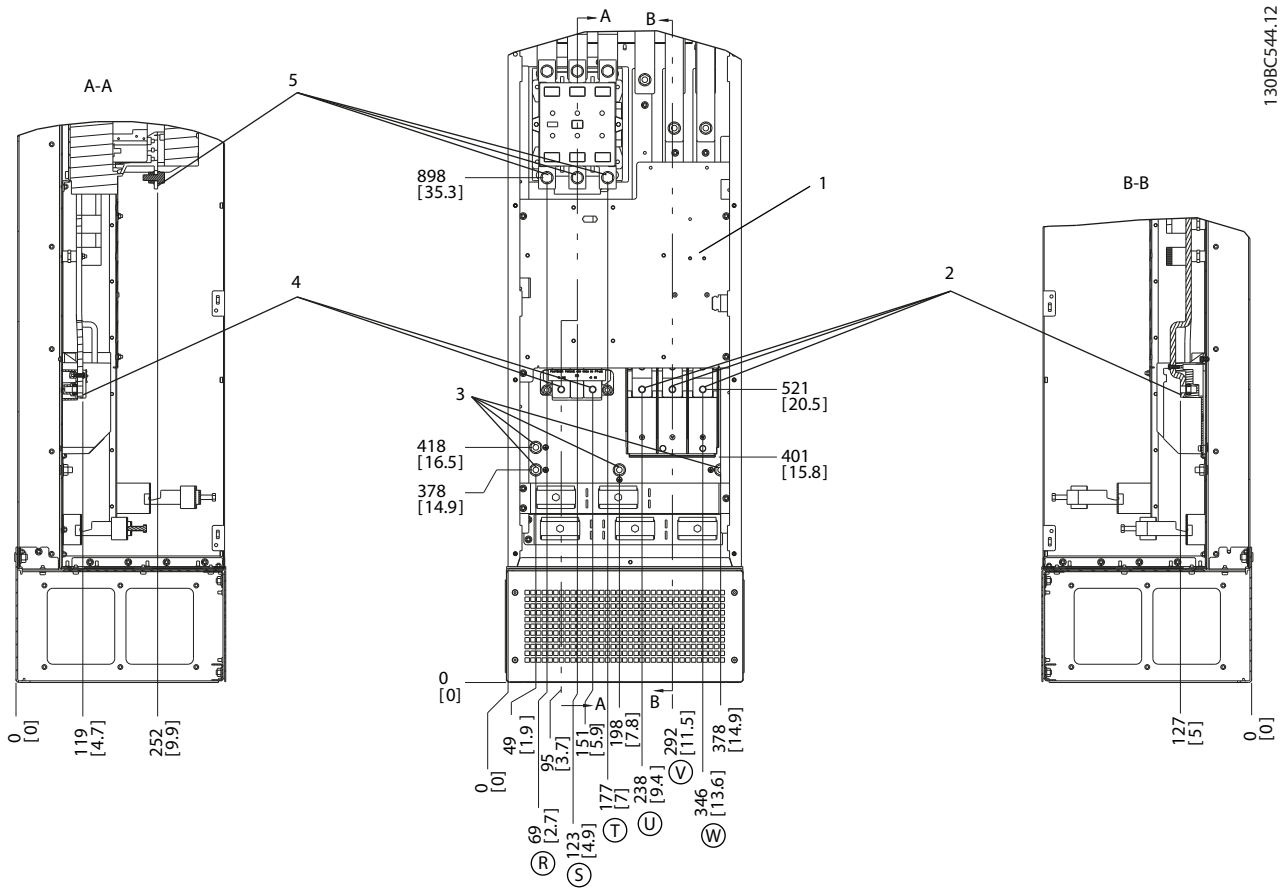

1.30BC544.12

3

1	TB6 Terminal block for contactor	4	Brake Terminals
2	Motor Terminals	5	Mains Terminals
3	Earth/Ground Terminals		

Illustration 3.20 Terminal Locations, D8h with Contactor Option

3

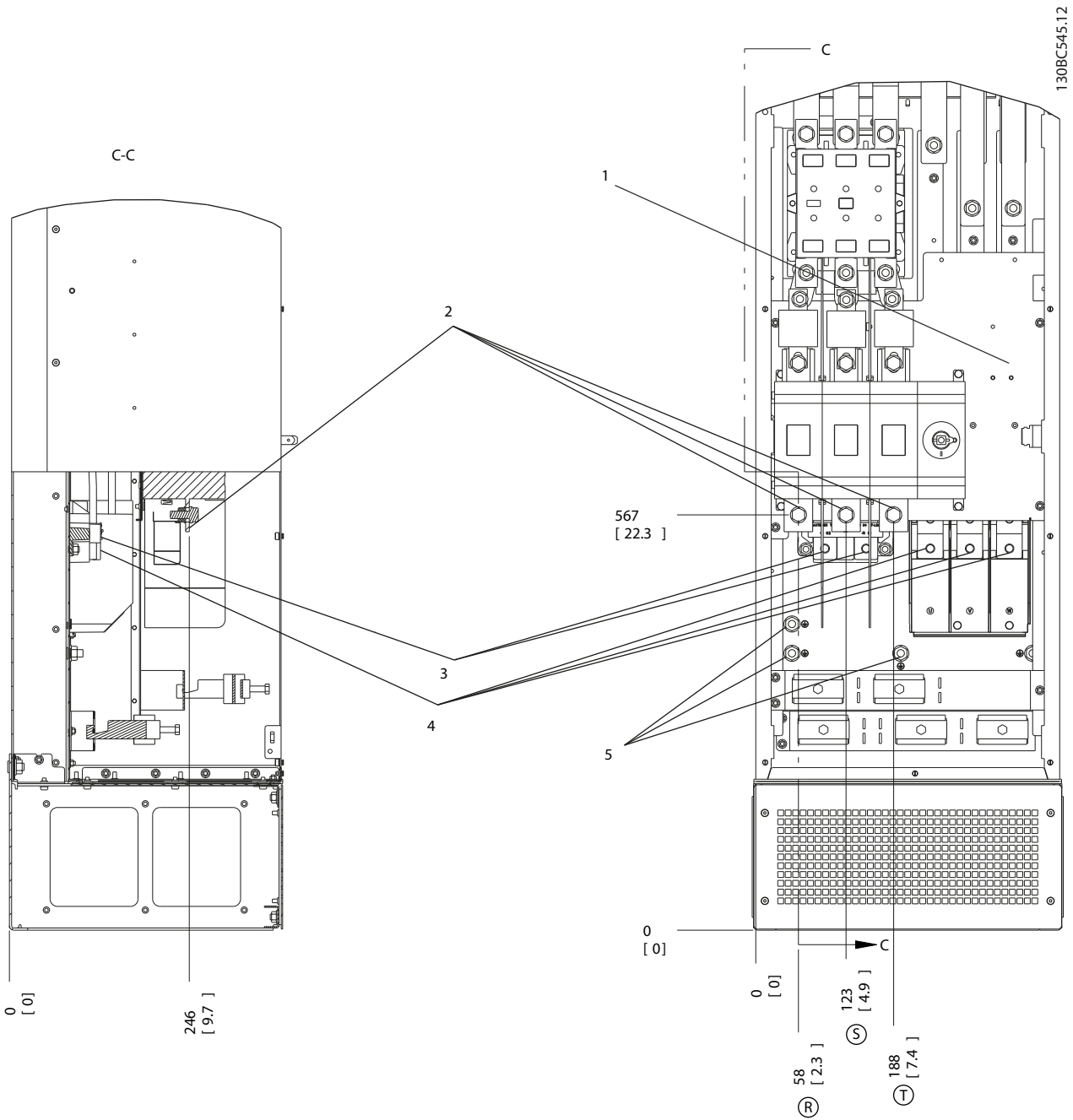

1 TB6 Terminal block for contactor	4 Motor Terminals
2 Mains Terminals	5 Earth/Ground Terminals
3 Brake Terminals	

Illustration 3.21 Terminal Locations, D8h with Contactor and Disconnect Options

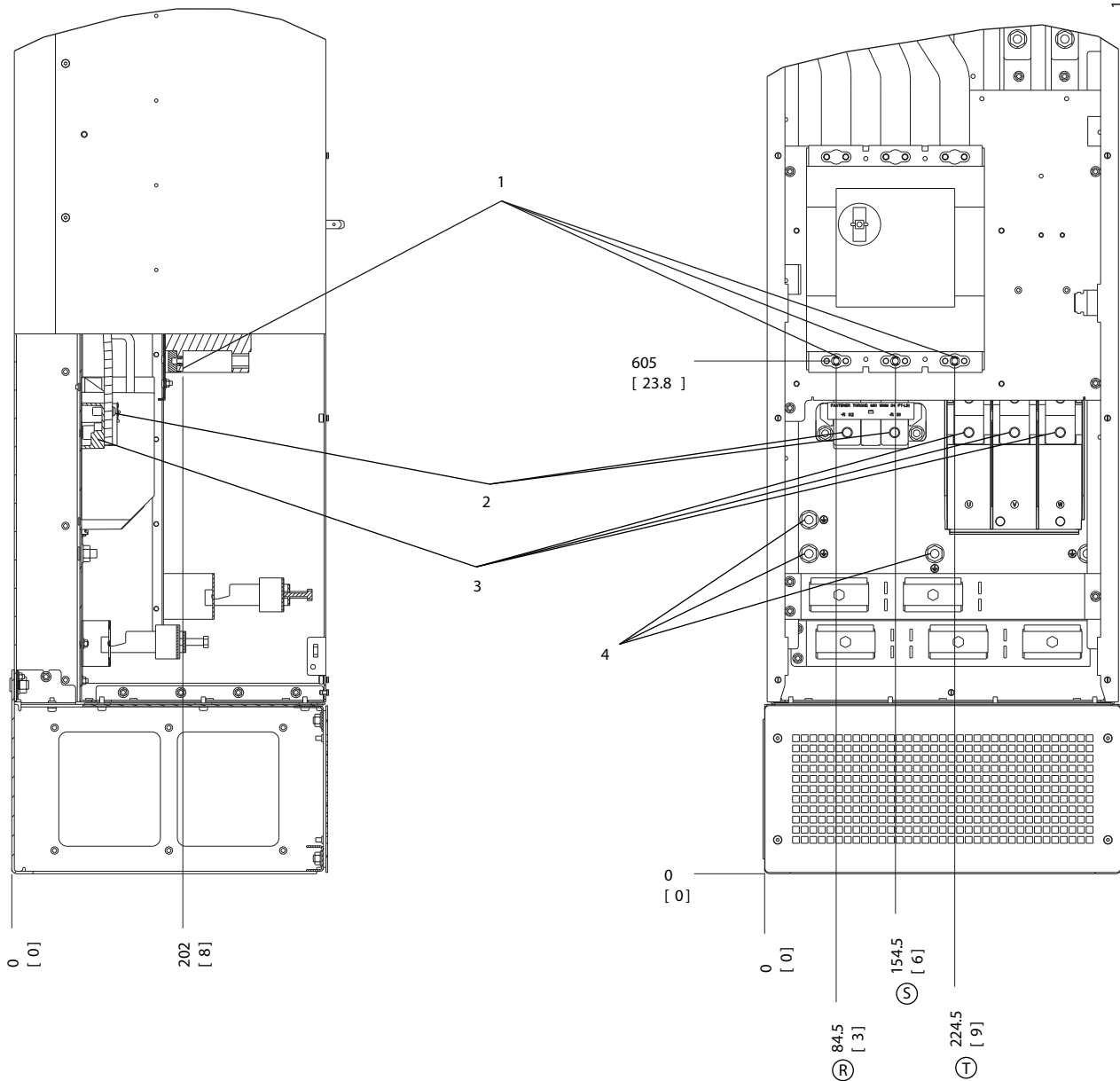

1 Mains Terminals	3 Motor Terminals
2 Brake Terminals	4 Earth/Ground Terminals

Illustration 3.22 Terminal Locations, D8h with Circuit Breaker Option

3.4.4 Motor Cable

Connect the motor to terminals U/T1/96, V/T2/97, W/T3/98. Ground to terminal 99. All types of 3-phase asynchronous standard motors can be used with a frequency converter unit. The factory setting is for clockwise rotation with the frequency converter output connected as follows:

Terminal no.	Function
96, 97, 98,	Mains U/T1, V/T2, W/T3
99	Ground

Table 3.3 Terminals for Motor Cable Connection

3.4.5 Motor Rotation Check

The direction of rotation can be changed by switching 2 phases in the motor cable, or by changing the setting of 4-10 Motor Speed Direction.

- Terminal U/T1/96 connected to U-phase
- Terminal V/T2/97 connected to V-phase
- Terminal W/T3/98 connected to W-phase

Table 3.4 Wiring for Changing Motor Direction

A motor rotation check can be performed using 1-28 Motor Rotation Check and following the steps shown in the display.

3.4.6 AC Mains Connection

- All frequency converters may be used with an isolated input source as well as with ground reference power lines. When supplied from an isolated mains source (IT mains or floating delta) or TT/TN-S mains with a grounded leg (grounded delta), set 14-50 RFI Filter to [0] Off. When off, the internal RFI filter capacitors between the chassis and the intermediate circuit are isolated. Isolating the capacitors prevents damage to the intermediate circuit and reduces ground capacity currents in accordance with IEC 61800-3.
- Size wiring is based upon the input current of the frequency converter.

- Comply with local and national electrical codes for cable sizes.
- Ground the cable in accordance with the instructions provided.
 - Connect 3-phase AC input power wiring to terminals L1, L2, and L3 (see Illustration 3.23).

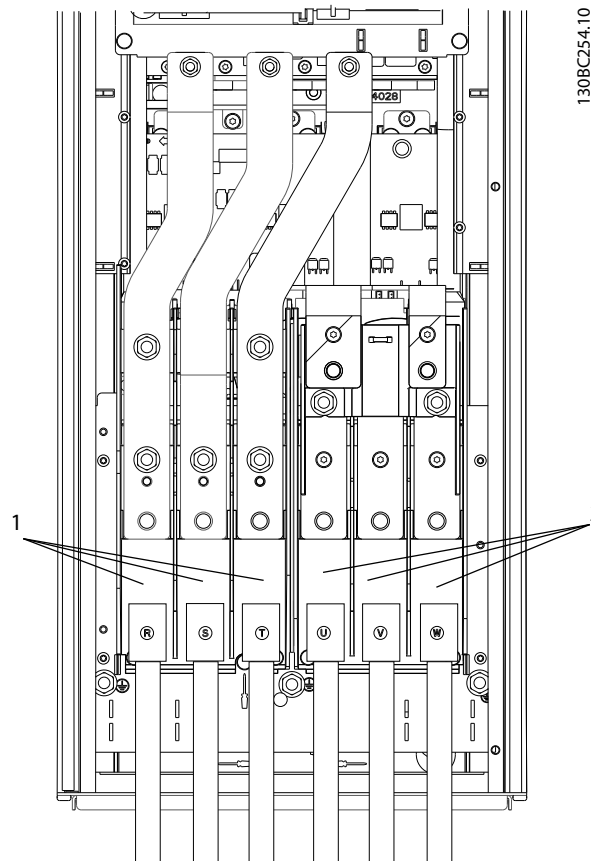

1	Mains connection
2	Motor connection

Illustration 3.23 Connecting to AC Mains

3.5 Control Wiring Connection

- Isolate control wiring from high power components in the frequency converter.
- If the frequency converter is connected to a thermistor for PELV isolation, optional thermistor control wiring must be reinforced/double insulated. A 24 V DC supply voltage is recommended.

3.5.1 Access

All terminals to the control cables are located underneath the LCP on the inside of the frequency converter. To access, open the door (IP21/54) or remove the front panel (IP20).

3.5.2 Using Screened Control Cables

Danfoss recommends braided screened/armoured cables to optimise EMC immunity of the control cables and the EMC emission from the motor cables.

The ability of a cable to reduce the incoming and outgoing radiation of electric noise depends on the transfer impedance (Z_T). The screen of a cable is normally designed to reduce the transfer of electric noise; however, a screen with a lower transfer impedance (Z_T) value is more effective than a screen with a higher transfer impedance (Z_T).

Transfer impedance (Z_T) is rarely stated by cable manufacturers, but it is often possible to estimate transfer impedance (Z_T) by assessing the physical design of the cable.

Transfer impedance (Z_T) can be assessed on the basis of the following factors:

- The conductivity of the screen material.
- The contact resistance between the individual screen conductors.
- The screen coverage, i.e. the physical area of the cable covered by the screen - often stated as a percentage value.
- Screen type, i.e. braided or twisted pattern.

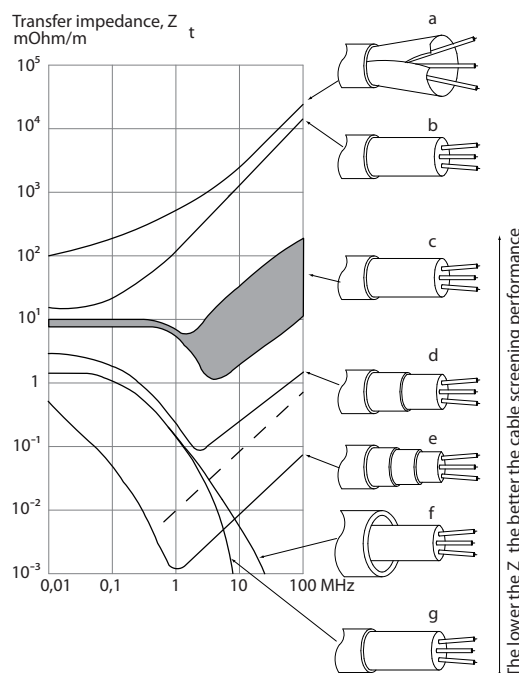

175ZA166:13

The lower the Z_T the better the cable screening performance

a	Aluminium-clad with copper wire
b	Twisted copper wire or armoured steel wire cable
c	Single-layer braided copper wire with varying percentage screen coverage (this is the typical Danfoss reference cable).
d	Double-layer braided copper wire
e	Twin layer of braided copper wire with a magnetic, screened/armoured intermediate layer
f	Cable that runs in copper tube or steel tube
g	Lead cable with 1.1 mm wall thickness

Illustration 3.24 Cable Screening Performance

3.5.3 Grounding of Screened Control Cables

Correct screening

The preferred method in most cases is to secure control and serial communication cables with screening clamps provided at both ends to ensure best possible high frequency cable contact. If the ground potential between the frequency converter and the PLC is different, electric noise may occur that disturbs the entire system. Solve this problem by fitting an equalizing cable next to the control cable. Minimum cable cross section: 16 mm².

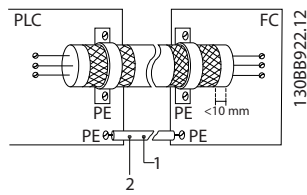

1	Min. 16 mm ²
2	Equalizing cable

Illustration 3.25 Correct Screening

50/60 Hz ground loops

With very long control cables, ground loops may occur. To eliminate ground loops, connect one end of the screen-to-ground with a 100 nF capacitor (keeping leads short).

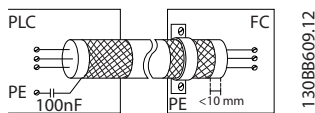
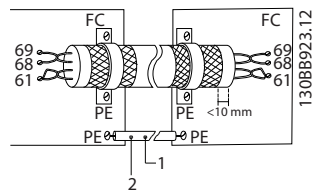

Illustration 3.26 Avoiding Ground Loops

Avoid EMC noise on serial communication

This terminal is connected to ground via an internal RC link. Use twisted-pair cables to reduce interference between conductors. The recommended method is shown below:



1	Min. 16 mm ²
2	Equalizing cable

Illustration 3.27 Avoiding EMC Noise

Alternatively, the connection to terminal 61 can be omitted:

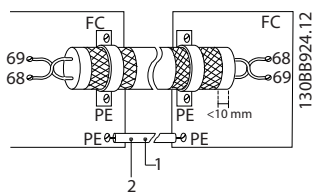

1	Min. 16 mm ²
2	Equalizing cable

Illustration 3.28 Screening without Using Terminal 61

3.5.4 Control Terminal Types

Terminal functions and default settings are summarised in chapter 3.5.6 Control Terminal Functions.

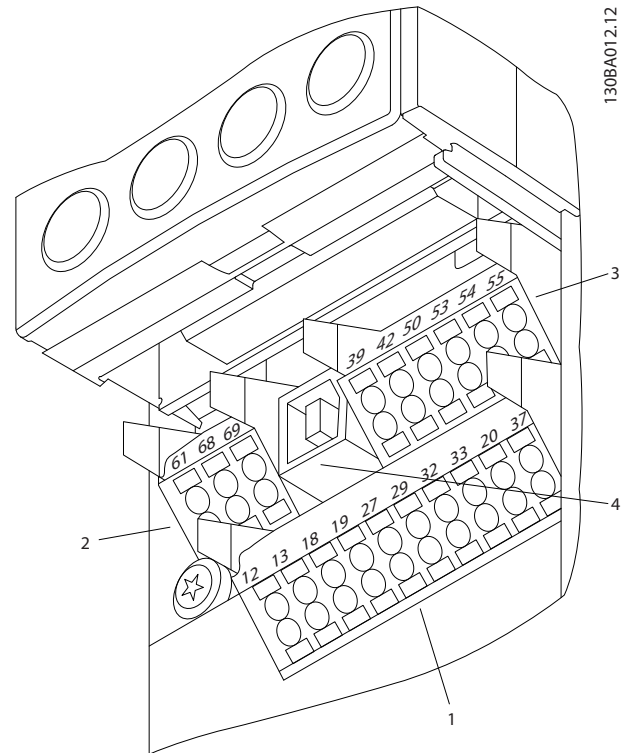

Illustration 3.29 Control Terminal Locations

- **Connector 1** provides:
 - 4 programmable digital input terminals
 - 2 additional digital terminals programmable as either input or output
 - 24 V DC terminal supply voltage
 - A common wire for optional customer supplied 24 V DC voltage
- **Connector 2** terminals (+)68 and (-)69 are for an RS-485 serial communications connection.
- **Connector 3** provides
 - 2 analog inputs
 - 1 analog output
 - 10 V DC supply voltage
 - Common wires for the inputs and output
- **Connector 4** is a USB port available for use with the MCT 10 Set-up Software.
- Also provided are 2 Form C relay outputs which are located on the power card.

- Some options available for ordering with the unit may provide additional terminals. See the manual provided with the equipment option.

3.5.5 Wiring to Control Terminals

Terminal plugs can be removed for easy access.

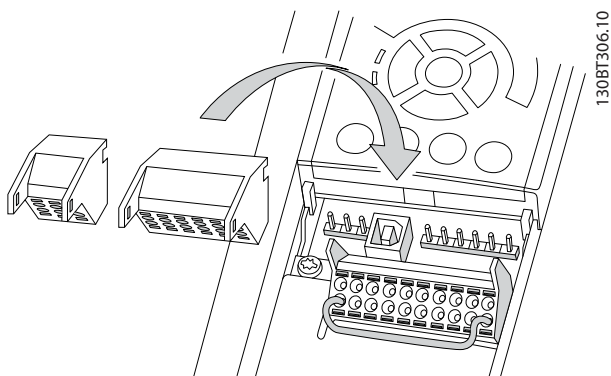

Illustration 3.30 Removal of Control Terminals

3.5.6 Control Terminal Functions

Frequency converter functions are commanded by receiving control input signals.

- Each terminal must be programmed for the function it is supporting in the parameters associated with that terminal. See *chapter 6 Programming* and *chapter 7 Application Examples* for terminals and associated parameters.
- It is important to confirm that the control terminal is programmed for the correct function. See *chapter 6 Programming* for details on accessing parameters and programming.
- The default terminal programming is intended to initiate frequency converter functioning in a typical operational mode.

3.5.6.1 Terminal 53 and 54 Switches

- Analog input terminals 53 and 54 can select either voltage (0 to 10 V) or current (0/4-20 mA) input signals.
- Remove power to the frequency converter before changing switch positions.
- Set switches A53 and A54 to select the signal type. U selects voltage, I selects current.
- The switches are accessible when the LCP has been removed (see *Illustration 3.31*).

NOTICE

Some option cards available for the unit may cover these switches and must be removed to change switch settings. Always remove power to the unit before removing option cards. Observe the discharge time in *Table 2.1*.

- Terminal 53 default is for a speed reference signal in open loop, which is set in *16-61 Terminal 53 Switch Setting*
- Terminal 54 default is for a feedback signal in closed loop, which is set in *16-63 Terminal 54 Switch Setting*

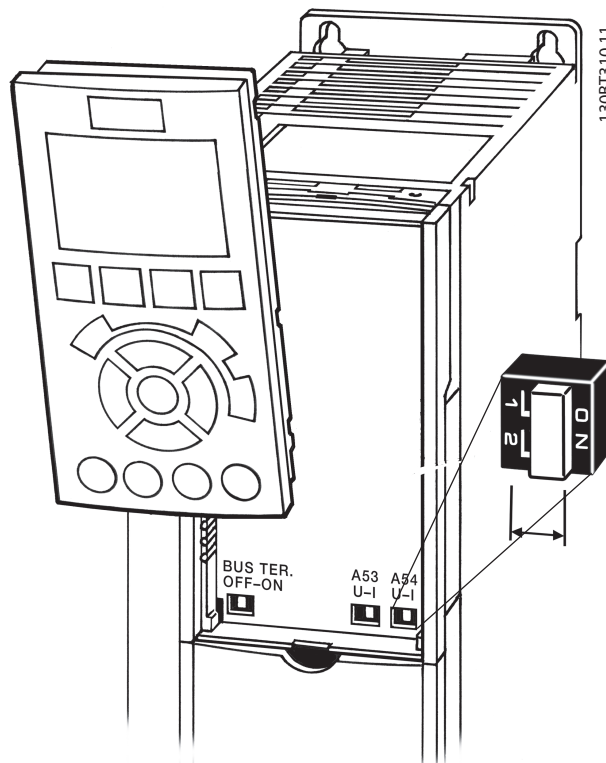

Illustration 3.31 Location of Terminals 53 and 54 Switches and Bus Termination Switch

STO is an option. To run STO, additional wiring for the frequency converter is required. Refer to *VLT® Frequency Converters Safe Torque Off Operating Instructions* for further information.

3.6 Serial Communication

RS-485 is a 2-wire bus interface compatible with multi-drop network topology, i.e. nodes can be connected as a bus, or via drop cables from a common trunk line. A total of 32 nodes can be connected to 1 network segment. Repeaters divide network segments. Each repeater functions as a node within the segment it is installed in. Each node connected within a given network must have a unique node address across all segments.

- Terminate each segment at both ends, using either the termination switch (S801) of the frequency converter or a biased termination resistor network.
- Always use screened twisted pair (STP) cable for bus cabling.
- Always follow good common installation practice.

Low-impedance ground connection of the screen at every node is important, including at high frequencies.

- Connect a large surface of the screen to ground, for example with a cable clamp or a conductive cable gland. It may be necessary to apply potential-equalizing cables to maintain the same ground potential throughout the network. Particularly in installations with long cables.
- To prevent impedance mismatch, always use the same type of cable throughout the entire network.
- When connecting a motor to the frequency converter, always use screened motor cable.

Cable	Screened twisted pair (STP)
Impedance	120 Ω
Max. cable length [m]	1200 (including drop lines) 500 station-to-station

Table 3.5 Cable Information

3.7 Optional Equipment

3.7.1 Load Share Terminals

Load share terminals enable the connection of the DC circuits of several frequency converters. Load share terminals are available in IP20 frequency converters and extend out the top of the frequency converter. A terminal cover, supplied with the frequency converter, must be installed to maintain the IP20 rating of the enclosure. *Illustration 3.32* shows both the covered and uncovered terminals.

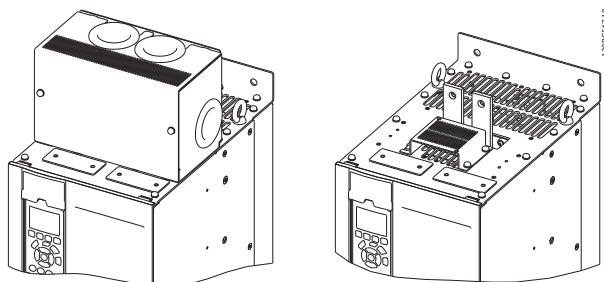

Illustration 3.32 Load Share or Regeneration Terminal with Cover (L) and without Cover (R)

3.7.2 Regeneration Terminals

Regen (regeneration) terminals can be supplied for applications that have a regenerative load. A regenerative unit, supplied by a third party, connects to the regen terminals so that power can be regenerated back onto the mains, resulting in energy savings. Regen terminals are available in IP20 frequency converters and extend out the top of the frequency converter. A terminal cover, supplied with the frequency converter, must be installed to maintain the IP20 rating of the enclosure. *Illustration 3.32* shows both the covered and uncovered terminals.

3.7.3 Anti-condensation Heater

An anti-condensation heater can be installed inside the frequency converter to prevent condensation from forming inside the enclosure when the unit is turned off. The heater is controlled by customer-supplied 230 V AC. For best results, operate the heater only when the unit is not running and turn the heater off when the unit is running.

3.7.4 Brake Chopper

A brake chopper can be supplied for applications that have a regenerative load. The brake chopper connects to a brake resistor, which consumes the braking energy, preventing an overvoltage fault on the DC bus. The braking chopper is automatically activated when the DC bus voltage exceeds a specified level, depending on the nominal voltage of the frequency converter.

3.7.5 Mains Shield

The mains shield is a Lexan cover installed inside the enclosure to provide protection according to VBG-4 accident-prevention requirements.

3.7.6 Mains Disconnect

The disconnect option is available in both varieties of option cabinets. The position of the disconnect changes based on the size of the options cabinet and whether or not other options are present. *Table 3.6* provides more detail about which disconnects are used.

Voltage [V]	Frequency converter model	Disconnect manufacturer and type
380–500 V	N110T5–N160T4	ABB OT400U03
	N200T5–N315T4	ABB OT600U03
525–690	N75KT7–N160T7	ABB OT400U03
	N200T7–N400T7	ABB OT600U03

Table 3.6 Mains Disconnect Types

3.7.7 Contactor

The contactor is powered by a customer-supplied 230 V AC 50/60 Hz signal.

Voltage [V]	Frequency converter model	Contactor manufacturer and type	IEC utilization category
380-500	N110T5–N160T4	GE CK95BE311N	AC-3
	N200T5–N250T4	GE CK11CE311N	AC-3
	N315T4	GE CK11CE311N	AC-1
525-690	N75KT7–N160T7	GE CK95BE311N	AC-3
	N200T7–N400T7	GE CK11CE311N	AC-3

Table 3.7 Contactor Types

NOTICE

In applications requiring UL listing, when the frequency converter is supplied with a contactor, the customer must provide external fusing to maintain the UL rating of the frequency converter and a short circuit current rating of 100,000 A. See *chapter 11.1.1 Power-dependent Specifications* for fuse recommendations.

3.7.8 Circuit Breaker

Table 3.8 provides details on the type of circuit breaker provided as an option with the various units and power ranges.

Voltage [V]	Frequency converter model	Circuit breaker manufacturer and type
380–500	N110T5–N132T5	ABB T5L400TW
	N160T5	ABB T5LQ400TW
	N200T5	ABB T6L600TW
	N250T5	ABB T6LQ600TW
	N315T5	ABB T6LQ800TW
525–690	N75KT7–N160T7	ABB T5L400TW
	N200T7–N315T7	ABB T6L600TW
	N400T7	ABB T6LQ600TW

Table 3.8 Circuit Breaker Types

4 Start Up and Commissioning

4.1 Pre-start

CAUTION

Before applying power to the unit, inspect the entire installation as detailed in *Table 4.1*. Check mark those items when completed.

4

Inspect for	Description	<input checked="" type="checkbox"/>
Auxiliary equipment	<ul style="list-style-type: none"> Look for auxiliary equipment, switches, disconnects, or input fuses/circuit breakers on the input power side of the frequency converter or output side to the motor. Ensure that they are ready for full speed operation. Check function and installation of any sensors used for feedback to the frequency converter. Remove power factor correction caps on motors, if present. 	
Cable routing	<ul style="list-style-type: none"> Use separate metallic conduits for each of the following: <ul style="list-style-type: none"> Input power Motor wiring Control wiring 	
Control wiring	<ul style="list-style-type: none"> Check for broken or damaged wires and loose connections. Check that control wiring is isolated from power and motor wiring for noise immunity. Check the voltage source of the signals, if necessary. Use shielded or twisted pair cable. Ensure that the shield is terminated correctly. 	
Cooling clearance	<ul style="list-style-type: none"> Measure that top and bottom clearance is adequate to ensure proper air flow for cooling. 	
EMC considerations	<ul style="list-style-type: none"> Check for proper installation regarding electromagnetic compatibility. 	
Environmental considerations	<ul style="list-style-type: none"> See equipment label for the maximum ambient operating temperature limits. Humidity levels must be 5–95%, non-condensing. 	
Fusing and circuit breakers	<ul style="list-style-type: none"> Check for proper fusing or circuit breakers. Check that all fuses are inserted firmly and in operational condition and that all circuit breakers are in the open position. 	
Grounding	<ul style="list-style-type: none"> The unit requires a ground wire from its chassis to the building ground. Check for good ground connections that are tight and free of oxidation. Grounding to conduit or mounting the back panel to a metal surface is not sufficient. 	
Input and output power wiring	<ul style="list-style-type: none"> Check for loose connections. Check that motor and mains are in separate conduit or separated screened cables. 	
Panel interior	<ul style="list-style-type: none"> Inspect that the unit interior is free of debris and corrosion. 	
Switches	<ul style="list-style-type: none"> Ensure that all switch and disconnect settings are in the proper positions. 	
Vibration	<ul style="list-style-type: none"> Check that the unit is mounted solidly or that shock mounts are used, as necessary. Check for an unusual amount of vibration. 	

Table 4.1 Start-up Checklist

4.2 Applying Power

⚠ WARNING

HIGH VOLTAGE!

Frequency converters contain high voltage when connected to the energised DC bus. Only qualified personnel should install, start up and maintain the frequency converters. Failure to let qualified personnel install, start up and maintain the frequency converters could result in death or serious injury.

⚠ WARNING

UNINTENDED START!

When the frequency converter is connected to the energised DC bus, the motor may start at any time. The frequency converter, motor, and any driven equipment must be in operational readiness. Failure to be in operational readiness when the frequency converter is connected to the energised DC bus could result in death, serious injury, equipment, or property damage.

1. Confirm input voltage is balanced within 3%. If not, correct input voltage imbalance before proceeding. Repeat procedure after voltage correction.
2. Ensure optional equipment wiring, if present, matches installation application.
3. Ensure that all operator devices are in the OFF position. Panel doors closed, or a cover mounted.
4. Apply power to the unit. DO NOT start the frequency converter now. For units with a disconnect switch, turn to the ON position to apply power to the frequency converter.

NOTICE

If the status line in the LCP reads AUTO REMOTE COAST, it indicates that the unit is ready to operate, but is missing an input signal on terminal 27.

4.3 Basic Operational Programming

Frequency converters require basic operational programming before running for best performance. Basic operational programming requires entering motor-nameplate data for the motor being operated and the minimum and maximum motor speeds. Parameter settings recommended are intended for start up and checkout purposes. Application settings may vary. See *chapter 5.1 Local Control Panel* for detailed instructions on entering data through the LCP.

Enter data with power ON, but before operating the frequency converter. There are 2 ways of programming the frequency converter: either by using the Smart Application

Set-up (SAS) or by using the procedure described further down. The SAS is a quick wizard for setting up the most commonly used applications. At the first power-up and after a reset the SAS appears on the LCP. Follow the instructions that appear on the successive screens for setting-up the applications listed. SAS can also be found under the Quick Menu. [Info] is used throughout the Smart Set-up to see help information for various selections, settings and messages.

NOTICE

The start conditions are ignored while in the wizard.

NOTICE

If no action is taken after first power-up or reset, the SAS screen will automatically disappear after 10 minutes.

When not using the SAS, enter data in accordance with the following procedure.

1. Press [Main Menu] twice on the LCP.
2. Press the navigation keys to scroll to parameter group 0-** Operation/Display.
3. Press [OK].

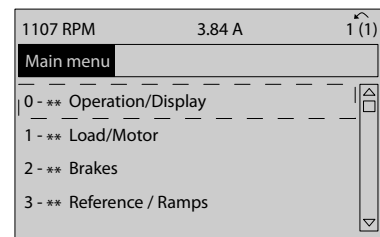

Illustration 4.1 0-** Operation/Display

4. Press the navigation keys to scroll to parameter group 0-0* Basic Settings and press [OK].

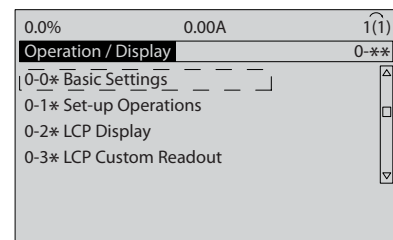

Illustration 4.2 0-0* Basic Settings

5. Press the navigation keys to scroll to 0-03 Regional Settings and press [OK].

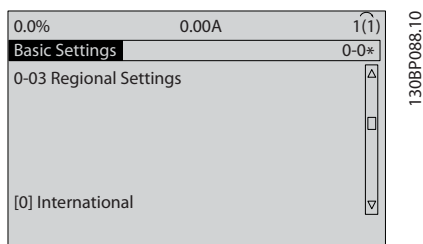

Illustration 4.3 0-03 Regional Settings

6. Press the navigation keys to select *International* or *North America* as appropriate and press [OK]. (This changes the default settings for a number of basic parameters. See *chapter 6.5 Parameter Menu Structure* for a complete list.)
7. Press [Quick Menu] on the LCP.
8. Press the navigation keys to scroll to parameter group *Q2 Quick Setup*.
9. Press [OK].

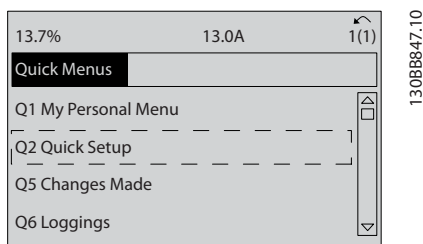

Illustration 4.4 Q2 Quick Setup

10. Select language and press [OK].

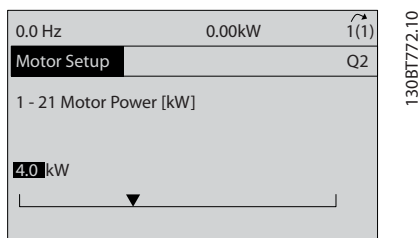

Illustration 4.5 Select Language

11. If a jumper wire is placed between control terminals 12 and 27 leave *5-12 Terminal 27 Digital Input* at factory default. Otherwise select *No Operation*. For frequency converters with an optional bypass, no jumper wire is required.
12. *3-02 Minimum Reference*
13. *3-03 Maximum Reference*
14. *3-41 Ramp 1 Ramp Up Time*
15. *3-42 Ramp 1 Ramp Down Time*
16. *3-13 Reference Site*. Linked to Hand/Auto* Local Remote.

4.4 Local-control Test

CAUTION

MOTOR START

Ensure that the motor, system and any attached equipment are ready for start. It is the responsibility of the user to ensure safe operation under any condition. Failure to ensure that the motor, system, and any attached equipment is ready for start could result in personal injury or equipment damage.

NOTICE

The [Hand On] key provides a local start command to the frequency converter. The [Off] key provides the stop function.

When operating in local mode, [▲] and [▼] increase and decrease the speed output of the frequency converter. [◀] and [▶] move the display cursor in the numeric display.

1. Press [Hand On].
2. Accelerate the frequency converter by pressing [▲] to full speed. Moving the cursor left of the decimal point provides quicker input changes.
3. Note any acceleration problems.
4. Press [Off].
5. Note any deceleration problems.

If acceleration problems were encountered:

- If warnings or alarms occur, see *chapter 9 Warnings and Alarms*.
- Check that motor data is entered correctly.
- Increase the ramp-up time in *3-41 Ramp 1 Ramp Up Time*.
- Increase the current limit in *4-18 Current Limit*.
- Increase the torque limit in *4-16 Torque Limit Motor Mode*.

If deceleration problems were encountered:

- If warnings or alarms occur, see *chapter 9 Warnings and Alarms*.
- Check that motor data is entered correctly.
- Increase the ramp-down time in *3-42 Ramp 1 Ramp Down Time*.
- Enable overvoltage control in *2-17 Over-voltage Control*.

See *chapter 5.1.1 Local Control Panel* for resetting the frequency converter after a trip.

NOTICE

Chapter 4.2 *Applying Power* and chapter 4.3 *Basic Operational Programming* conclude the procedures for applying power to the frequency converter, basic programming, set-up, and functional testing.

4.5 System Start Up

Complete user wiring and application programming before performing the procedure in this section. See chapter 7 *Application Examples* for application set-up information. The following procedure is recommended after application set-up by the user is completed.

CAUTION**MOTOR START!**

Ensure that the motor, system, and any attached equipment are ready for start. It is the responsibility of the user to ensure safe operation under any condition. Failure to ensure that the motor, system, and any attached equipment are ready for start could result in personal injury or equipment damage.

1. Press [Auto On].
2. Ensure that external control functions are properly wired to the frequency converter and all programming is completed.
3. Apply an external run command.
4. Adjust the speed reference throughout the speed range.
5. Remove the external run command.
6. Note any problem.

If warnings or alarms occur, see chapter 9 *Warnings and Alarms*.

5 User Interface

5.1 Local Control Panel

The local control panel (LCP) is the combined display and keypad on the front of the unit. The LCP is the user interface to the frequency converter.

The LCP has several user functions.

- Start, stop, and control speed when in local control
- Display operational data, status, warnings and cautions
- Programming frequency converter functions
- Manually reset the frequency converter after a fault when auto-reset is inactive

An optional numeric LCP (NLCP) is also available. The NLCP operates in a manner similar to the LCP. See the *Programming Guide*, for details on use of the NLCP.

5.1.1 LCP Layout

The LCP is divided into 4 functional groups (see *Illustration 5.1*).

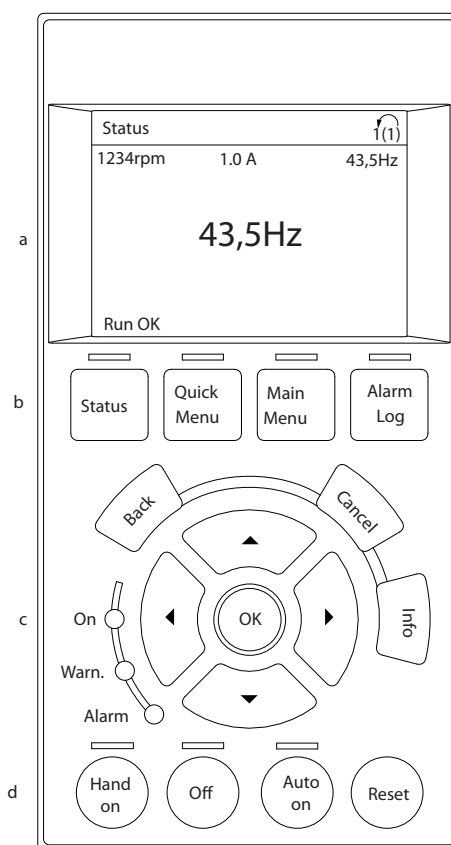

130BC362.10

a	Display area.
b	Display menu keys for changing the display to show status options, programming, or error message history.
c	Navigation keys for programming functions, moving the display cursor, and speed control in local operation. The status indicator lights are also in this group.
d	Operational mode keys and reset.

Illustration 5.1 LCP

5.1.2 Setting LCP Display Values

The display area is activated when the frequency converter receives power from mains voltage, a DC bus terminal, or an external 24 V DC supply.

The information displayed on the LCP can be customized for user application.

- Each display readout has a parameter associated with it
- Options are selected in the quick menu Q3-13 *Display Settings*
- Display 2 has an alternate larger display option
- The frequency converter status at the bottom line of the display is generated automatically and is not selectable

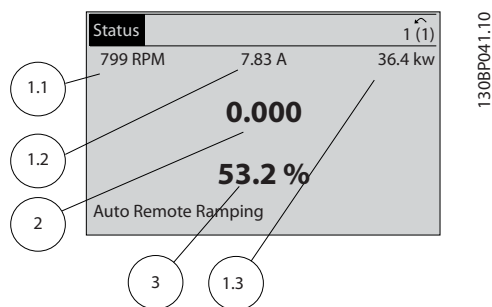

Illustration 5.2 Display Readouts

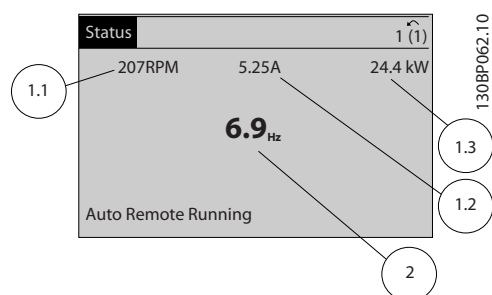

Illustration 5.3 Display Readouts

5.1.3 Display Menu Keys

Menu keys are used for menu access for parameter set-up, toggling through status display modes during normal operation, and viewing fault log data.



Illustration 5.4 Menu Keys

Key	Function
Status	Shows operational information. <ul style="list-style-type: none"> • In Auto mode, press to toggle between status readout displays. • Press repeatedly to scroll through each status display. • Press [Status] plus [▲] or [▼] to adjust the display brightness. • The symbol in the upper right corner of the display shows the direction of motor rotation and which set-up is active. This is not programmable.
Quick Menu	Allows access to programming parameters for initial set-up instructions and many detailed application instructions. <ul style="list-style-type: none"> • Press to access Q2 <i>Quick Set-up</i> for sequenced instructions to program the basic frequency controller set-up. • Follow the sequence of parameters as presented for the function set-up.
Main Menu	Allows access to all programming parameters. <ul style="list-style-type: none"> • Press twice to access top-level index. • Press once to return to the last location accessed. • Press to enter a parameter number for direct access to that parameter.
Alarm Log	Displays a list of current warnings, the last 10 alarms, and the maintenance log. <ul style="list-style-type: none"> • For details about the frequency converter before it entered the alarm mode, select the alarm number using the navigation keys and press [OK].

Table 5.1 Function Description Menu Keys

5.1.4 Navigation Keys

Navigation keys are used for programming functions and moving the display cursor. The navigation keys also provide speed control in local (hand) operation. There are also 3 frequency converter status indicator lights in this area.

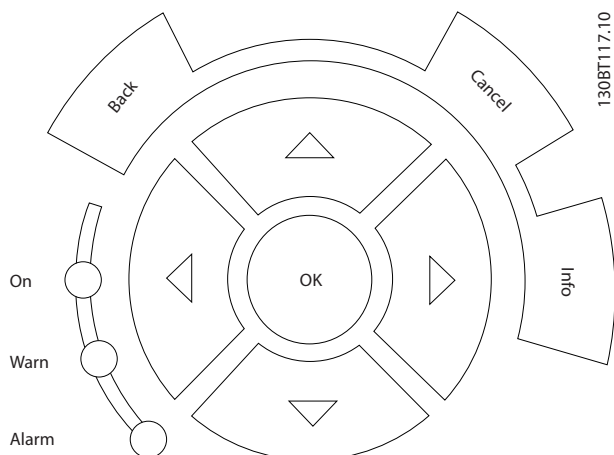

Illustration 5.5 Navigation Keys

Key	Function
Back	Reverts to the previous step or list in the menu structure.
Cancel	Cancels the last change or command as long as the display mode has not changed.
Info	Press for a definition of the function being displayed.
Navigation Keys	Press the 4 navigation keys to move between items in the menu.
OK	Press to access parameter groups or to enable a choice.

Table 5.2 Navigation Keys Functions

Light	Indicator	Function
Green	ON	The ON light activates when the frequency converter receives power from mains voltage, a DC bus terminal, or an external 24 V supply.
Yellow	WARN	When warning conditions are met, the yellow WARN light comes on and text appears in the display area identifying the problem.
Red	ALARM	A fault condition causes the red alarm light to flash and an alarm text is displayed.

Table 5.3 Indicator Lights Functions

5.1.5 Operation Keys

Operation keys are located at the bottom of the LCP.

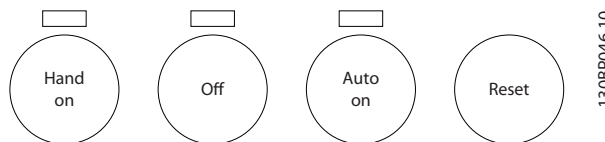

Illustration 5.6 Operation Keys

Key	Function
Hand On	Starts the frequency converter in local control. <ul style="list-style-type: none"> • Use the navigation keys to control frequency converter speed. • An external stop signal by control input or serial communication overrides the local hand on.
Off	Stops the motor, but does not remove power to the frequency converter.
Auto On	Puts the system in remote operational mode. <ul style="list-style-type: none"> • Responds to an external start command by control terminals or serial communication. • Speed reference is from an external source.
Reset	Resets the frequency converter manually after a fault has been cleared.

Table 5.4 Operation Keys Functions

5.2 Back Up and Copying Parameter Settings

Programming data is stored internally in the frequency converter.

- The data can be uploaded into the LCP memory as a storage back up.
- Once stored in the LCP, the data can be downloaded back into the frequency converter.
- Data can also be downloaded into other frequency converters by connecting the LCP into those units and downloading the stored settings. (This is a quick way to program multiple units with the same settings).
- Initialisation of the frequency converter to restore factory default settings does not change data stored in the LCP memory.

⚠ WARNING**UNINTENDED START**

When the frequency converter is connected to AC mains, or DC power supply, the motor may start at any time. Unintended start during programming, service or repair work can result in death, serious injury, or property damage. The motor can start by means of an external switch, a serial bus command, an input reference signal from the LCP, or after a cleared fault condition.

To prevent unintended motor start:

- Disconnect the frequency converter from mains.
- Press [Off/Reset] on the LCP, before programming parameters.
- The frequency converter, motor, and any driven equipment must be fully wired and assembled when the frequency converter is connected to AC mains, or DC power supply.

5.2.1 Uploading Data to the LCP

1. Press [Off] to stop the motor before uploading or downloading data.
2. Go to *0-50 LCP Copy*.
3. Press [OK].
4. Select *All to LCP*.
5. Press [OK]. A progress bar shows the uploading process.
6. Press [Hand On] or [Auto On] to return to normal operation.

5.2.2 Downloading Data from the LCP

1. Press [Off] to stop the motor before uploading or downloading data.
2. Go to *0-50 LCP Copy*.
3. Press [OK].
4. Select *All from LCP*.
5. Press [OK]. A progress bar shows the downloading process.
6. Press [Hand On] or [Auto On] to return to normal operation.

5.3 Restoring Default Settings

NOTICE

Initialisation restores the unit to factory default settings. Any programming, motor data, localisation, and monitoring records are lost. Uploading data to the LCP provides a back-up before initialisation.

Restoring the frequency converter parameter settings back to default values is done by initialisation of the frequency converter. Initialisation can be carried out via *14-22 Operation Mode* or manually.

- Initialisation using *14-22 Operation Mode* does not change frequency converter data such as operating hours, serial communication selections, personal menu settings, fault log, alarm log, and other monitoring functions.
- Using *14-22 Operation Mode* is generally recommended.
- Manual initialisation erases all motor, programming, localisation, and monitoring data and restores factory default settings.

5.3.1 Recommended Initialisation

1. Press [Main Menu] twice to access parameters.
2. Scroll to *14-22 Operation Mode*.
3. Press [OK].
4. Scroll to *Initialisation*.
5. Press [OK].
6. Remove power to the unit and wait for the display to turn off.
7. Apply power to the unit.

Default parameter settings are restored during start-up. This may take slightly longer than normal.

8. Alarm 80 is displayed.
9. Press [Reset] to return to operation mode.

5.3.2 Manual Initialisation

1. Remove power to the unit and wait for the display to turn off.
2. Press and hold [Status], [Main Menu], and [OK] at the same time and apply power to the unit.

Factory default parameter settings are restored during start-up. This may take slightly longer than normal.

Manual initialisation does not reset the following frequency converter information:

- *15-00 Operating hours*
- *15-03 Power Up's*
- *15-04 Over Temp's*
- *15-05 Over Volt's*

6 Programming

6.1 Introduction

The frequency converter is programmed for its application functions using parameters. Parameters are accessed by pressing either [Quick Menu] or [Main Menu] on the LCP. (See *chapter 5.1 Local Control Panel* for details on using the LCP function keys). Parameters may also be accessed via a PC using the MCT 10 Set-up Software (see *chapter 6.6.1 Remote Programming with MCT 10 Set-up Software*).

The Quick Menu is intended for initial start-up (Q2-** *Quick Set-up*) and detailed instructions for common frequency converter applications (Q3-** *Function Set-up*). Step-by-step instructions are provided. These instructions enable the user to walk through the parameters used for programming applications in their proper sequence. Data entered in a parameter can change the options available in the parameters following that entry. The Quick Menu presents easy guidelines for getting most systems up and running.

The Main Menu accesses all parameters and allows for advanced frequency converter applications.

6.2 Programming Example

Here is an example for programming the frequency converter for a common application in open loop using the quick menu.

- This procedure programs the frequency converter to receive a 0-10 V DC analog control signal on input terminal 53
- The frequency converter will respond by providing 20-50 Hz output to the motor proportional to the input signal (0-10 V DC=20-50 Hz)

This is a common pump or fan application.

Press [Quick Menu] and select the following parameters using the navigation keys to scroll to the titles and press [OK] after each action.

1. Q3 Function Setups
2. Parameter Data Set

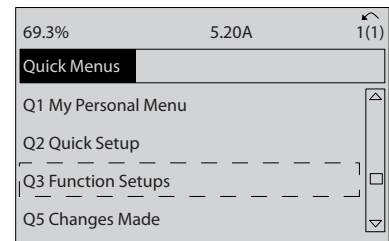

130BT112.10

Illustration 6.1 Q3 Function Setups

3. Q3-2 Open Loop Settings

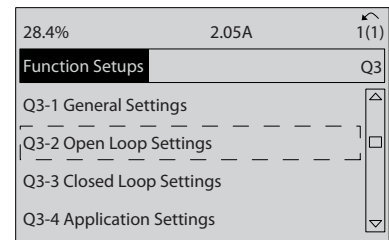

130BT760.10

Illustration 6.2 Q3-2 Open Loop Settings

4. Q3-21 Analog Reference

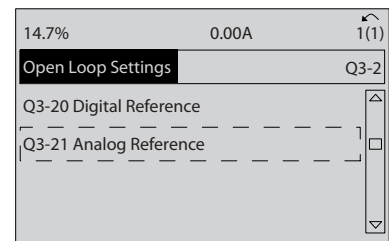

130BT761.10

Illustration 6.3 Q3-21 Analog Reference

5. 3-02 Minimum Reference. Set minimum internal frequency converter reference to 0 Hz. (This sets the minimum frequency converter speed at 0 Hz).

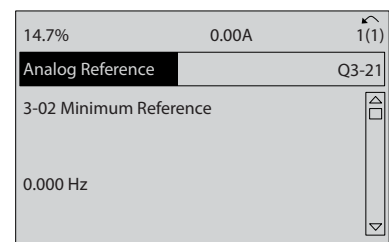

130BT762.10

Illustration 6.4 3-02 Minimum Reference

6. *3-03 Maximum Reference.* Set maximum internal frequency converter reference to 60 Hz. (This sets the maximum frequency converter speed at 60 Hz. Note that 50/60 Hz is a regional variation).

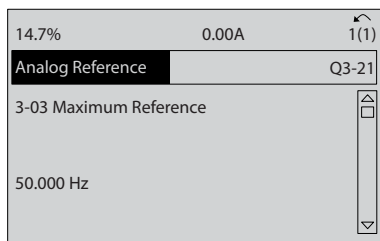

130BT763.11

Illustration 6.5 3-03 Maximum Reference

7. *6-10 Terminal 53 Low Voltage.* Set minimum external voltage reference on terminal 53 at 0 V. (This sets the minimum input signal at 0 V).

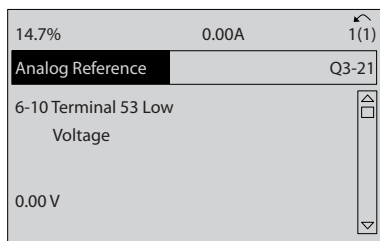

130BT764.10

Illustration 6.6 6-10 Terminal 53 Low Voltage

8. *6-11 Terminal 53 High Voltage.* Set maximum external voltage reference on terminal 53 at 10 V. (This sets the maximum input signal at 10 V).

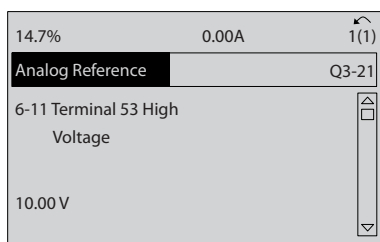

130BT765.10

Illustration 6.7 6-11 Terminal 53 High Voltage

9. *6-14 Terminal 53 Low Ref./Feedb. Value.* Set minimum speed reference on terminal 53 at 20 Hz. (This tells the frequency converter that the minimum voltage received on terminal 53 (0 V) equals 20 Hz output).

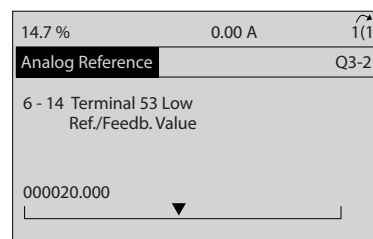

130BT773.11

Illustration 6.8 6-14 Terminal 53 Low Ref./Feedb. Value

10. *6-15 Terminal 53 High Ref./Feedb. Value.* Set maximum speed reference on terminal 53 at 50 Hz. (This tells the frequency converter that the maximum voltage received on terminal 53 (10 V) equals 50 Hz output).

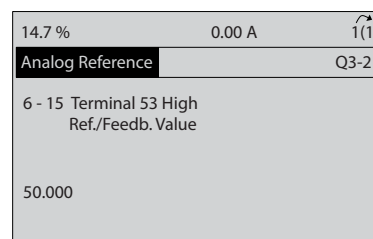

130BT774.11

Illustration 6.9 6-15 Terminal 53 High Ref./Feedb. Value

With an external device providing a 0-10 V control signal connected to frequency converter terminal 53, the system is now ready for operation.

NOTICE

The scroll bar on the right in the last illustration of the display is at the bottom, indicating the procedure is complete.

Illustration 6.10 shows the wiring connections used to enable this set up.

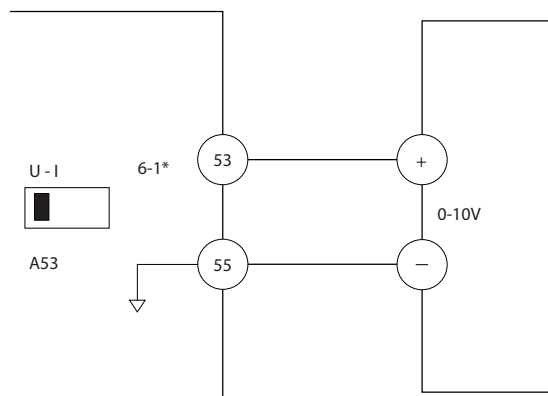

130BB482.10

Illustration 6.10 Wiring Example for External Device Providing 0-10 V Control Signal

6.3 Control Terminal Programming Examples

Control terminals can be programmed.

- Each terminal has specified functions it is capable of performing.
- Parameters associated with the terminal enable the function.
- For proper frequency converter functioning, the control terminals must be:
 - Wired properly
 - Programmed for the intended function
 - Receiving a signal

See *Table 6.1* for control terminal parameter number and default setting. (Default setting can change based on the selection in *0-03 Regional Settings*).

The following example shows accessing terminal 18 to see the default setting.

1. Press [Main Menu] twice, scroll to parameter group 5-** *Digital In/Out Parameter Data Set* and press [OK].

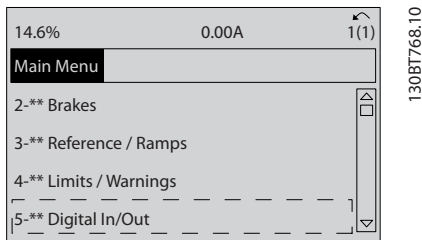

Illustration 6.11 Main Menu Display Example

2. Scroll to parameter group 5-1* *Digital Inputs* and press [OK].

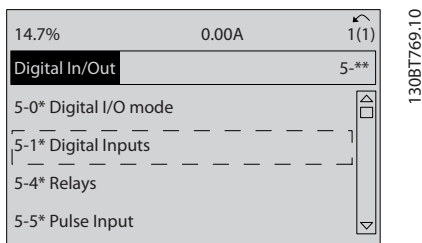

Illustration 6.12 Parameter Group Display Example

3. Scroll to 5-10 *Terminal 18 Digital Input*. Press [OK] to access function choices. The default setting *Start* is shown.

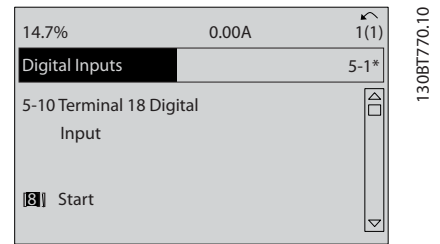

Illustration 6.13 Function Choice Display Example

6.4 International/North American Default Parameter Settings

Setting *0-03 Regional Settings* [0] *International* or [1] *North America* changes the default settings for some parameters. *Table 6.1* lists those parameters that are affected.

Parameter	International default parameter value	North American default parameter value
0-03 Regional Settings	International	North America
0-71 Date Format	DD-MM-YYYY	MM/DD/YYYY
0-72 Time Format	24 h	12 h
1-20 Motor Power [kW]	See Note 1	See Note 1
1-21 Motor Power [HP]	See Note 2	See Note 2
1-22 Motor Voltage	230 V/400 V/575 V	208 V/460 V/575 V
1-23 Motor Frequency	50 Hz	60 Hz
3-03 Maximum Reference	50 Hz	60 Hz
3-04 Reference Function	Sum	External/Preset
4-13 Motor Speed High Limit [RPM] See Note 3	1500 RPM	1800 RPM
4-14 Motor Speed High Limit [Hz] See Note 4	50 Hz	60 Hz
4-19 Max Output Frequency	100 Hz	120 Hz
4-53 Warning Speed High	1500 RPM	1800 RPM
5-12 Terminal 27 Digital Input	Coast inverse	External interlock
5-40 Function Relay	Alarm	No alarm
6-15 Terminal 53 High Ref./Feedb. Value	50	60
6-50 Terminal 42 Output	Speed 0-HighLim	Speed 4-20 mA
14-20 Reset Mode	Manual reset	Infinite auto reset

Parameter	International default parameter value	North American default parameter value
22-85 Speed at Design Point [RPM] See Note 3	1500 RPM	1800 RPM
22-86 Speed at Design Point [Hz]	50 Hz	60 Hz
24-04 Fire Mode Max Reference	50 Hz	60 Hz

Table 6.1 International/North American Default Parameter Settings

6.5 Parameter Menu Structure

Establishing the correct programming for applications often requires setting functions in several related parameters. These parameter settings provide the frequency converter with the system details it needs to operate properly. System details may include such things as:

- Input and output signal types
- Programming terminals
- Minimum and maximum signal ranges
- Custom displays
- Automatic restart
- Other features
- See the LCP display to view detailed parameter programming and setting options.
- Press [Info] in any menu location to view additional details for that function.
- Press and hold [Main Menu] to enter a parameter number for direct access to that parameter.
- Details for common application set-ups are provided in *chapter 7 Application Examples*.

0-0*	Operation / Display	1-11	Motor Model	1-76	Start Current	3-03	Maximum Reference	4-1*	Motor Limits
0-0*	Basic Settings	1-14	Damping Gain	1-8*	Stop Adjustments	3-04	Reference Function	4-10	Motor Speed Direction
0-01	Language	1-15	Low Speed Filter Time Const.	1-80	Function at Stop	3-1*	References	4-11	Motor Speed Low Limit [RPM]
0-02	Motor Speed Unit	1-16	High Speed Filter Time Const.	1-81	Min Speed for Function at Stop [RPM]	3-10	Preset Reference	4-12	Motor Speed Low Limit [Hz]
0-03	Regional Settings	1-17	Voltage filter time const.	1-82	Min Speed for Function at Stop [Hz]	3-11	Jog Speed [Hz]	4-13	Motor Speed High Limit [RPM]
0-04	Operating State at Power-up (Hand)	1-2*	Motor Data	1-83	Precise Stop Function	3-12	Catch up/slow Down Value	4-14	Motor Speed High Limit [Hz]
0-09	Performance Monitor	1-20	Motor Power [kW]	1-84	Precise Stop Counter Value	3-13	Reference Site	4-16	Torque Limit Motor Mode
0-1*	Set-up Operations	1-21	Motor Power [HP]	1-85	Precise Stop Speed Compensation	3-14	Preset Relative Reference	4-17	Torque Limit Generator Mode
0-10	Active Set-up	1-22	Motor Voltage		Delay	3-15	Reference Resource 1	4-18	Current Limit
0-11	Edit Set-up	1-23	Motor Frequency	1-9*	Motor Temperature	3-16	Reference Resource 2	4-19	Max Output Frequency
0-12	This Set-up Linked to	1-24	Motor Current	1-90	Motor Thermal Protection	3-17	Reference Resource 3	4-2*	Limit Factors
0-13	Readout: Linked Set-ups	1-25	Motor Nominal Speed	1-91	Motor External Fan	3-18	Relative Scaling Reference Resource	4-20	Torque Limit Factor Source
0-14	Readout: Edit Set-ups / Channel	1-26	Motor Cont. Rated Torque	1-93	Thermistor Resource	3-19	Jog Speed [RPM]	4-21	Speed Limit Factor Source
0-15	Readout: actual setup	1-29	Automatic Motor Adaptation (AMA)	1-94	ATEX ETR cur.lim. speed reduction	3-4*	Ramp 1	4-3*	Motor Speed Mon.
0-2*	LCP Display	1-3*	Adv. Motor Data	1-95	KTY Sensor Type	3-40	Ramp 1 Type	4-30	Motor Feedback Loss Function
0-20	Display Line 1.1 Small	1-30	Stator Resistance (Rs)	1-96	KTY Thermistor Resource	3-41	Ramp 1 Ramp Up Time	4-31	Motor Feedback Speed Error
0-21	Display Line 1.2 Small	1-31	Rotor Resistance (Rr)	1-97	KTY Threshold level	3-42	Ramp 1 Ramp Down Time	4-32	Motor Feedback Loss Timeout
0-22	Display Line 1.3 Small	1-33	Stator Leakage Reactance (X1)	1-98	ATEX ETR interpol. points freq.	3-45	Ramp 1 S-ramp Ratio at Accel. Start	4-34	Tracking Error Function
0-23	Display Line 2 Large	1-34	Rotor Leakage Reactance (X2)	1-99	ATEX ETR interpol. points current	3-46	Ramp 1 S-ramp Ratio at Decel. Start	4-35	Tracking Error
0-24	Display Line 3 Large	1-35	Main Reactance (Xh)	2-*	Brakes	3-47	Ramp 1 S-ramp Ratio at Decel. Start	4-36	Tracking Error Timeout
0-25	My Personal Menu	1-36	Iron Loss Resistance (Rfe)	2-0*	DC-Brake	3-48	Ramp 1 S-ramp Ratio at Decel. End	4-37	Tracking Error Ramping
0-3*	LCP Custom Readout	1-37	d-axis Inductance (Ld)	2-00	DC Hold Current	3-5*	Ramp 2	4-38	Tracking Error Ramping Timeout
0-30	Unit for User-defined Readout	1-38	q-axis Inductance (Lq)	2-01	DC Brake Current	3-50	Ramp 2 Type	4-39	Tracking Error After Ramping Timeout
0-31	Min Value of User-defined Readout	1-39	Motor Poles	2-02	DC Braking Time	3-51	Ramp 2 Ramp Up Time	4-5*	Adj. Warnings
0-32	Max Value of User-defined Readout	1-40	Back EMF at 1000 RPM	2-03	DC Brake Cut In Speed [Hz]	3-52	Ramp 2 Ramp Down Time	4-50	Warning Current Low
0-37	Display Text 1	1-41	Motor Angle Offset	2-04	DC Brake Cut In Speed [RPM]	3-55	Ramp 2 S-ramp Ratio at Accel. Start	4-51	Warning Current High
0-38	Display Text 2	1-44	d-axis Inductance Sat. (LdSat)	2-05	Maximum Reference	3-56	Ramp 2 S-ramp Ratio at Accel. End	4-52	Warning Speed Low
0-39	Display Text 3	1-45	q-axis Inductance Sat. (LqSat)	2-06	Maximum Reference	3-57	Ramp 2 S-ramp Ratio at Decel. Start	4-53	Warning Speed High
0-4*	LCP keypad	1-46	Position Detection Gain	2-07	Parking Time	3-58	Ramp 2 S-ramp Ratio at Decel. End	4-54	Warning Reference Low
0-40	[Hand on] key on LCP	1-47	Low Speed Torque Calibration	2-1*	Brake Energy Funct.	3-6*	Ramp 3	4-55	Warning Reference High
0-41	[Off] key on LCP	1-48	Inductance Sat. Point	2-10	Brake Function	3-60	Ramp 3 Type	4-56	Warning Feedback Low
0-42	[Auto on] key on LCP	1-5*	Load Indep. Setting	2-11	Brake Resistor (ohm)	3-61	Ramp 3 Ramp up Time	4-57	Warning Feedback High
0-43	[Reset] key on LCP	1-50	Motor Magnetisation at Zero Speed	2-12	Brake Power Limit (kW)	3-62	Ramp 3 Ramp down Time	4-58	Missing Motor Phase Function
0-44	[Off/Reset] key on LCP	1-51	Min Speed Normal Magnetising [RPM]	2-13	Brake Power Monitoring	3-65	Ramp 3 S-ramp Ratio at Accel. Start	4-6*	Speed Bypass
0-45	[Drive Bypass] key on LCP	1-52	Min Speed Normal Magnetising [Hz]	2-15	Brake Check	3-66	Ramp 3 S-ramp Ratio at Accel. End	4-60	Bypass Speed From [RPM]
0-45	[Copy/Save] key on LCP	1-53	Model Shift Frequency	2-16	AC brake Max. Current	3-67	Ramp 3 S-ramp Ratio at Decel. Start	4-61	Bypass Speed To [RPM]
0-50	LCP Copy	1-54	Voltage reduction in fieldweakening	2-17	Over-voltage Control	3-68	Ramp 3 S-ramp Ratio at Decel. End	4-62	Bypass Speed To [Hz]
0-51	Set-up Copy	1-55	U/f Characteristic - U	2-18	Brake Check Condition	3-7*	Ramp 4	4-63	Bypass Speed To [Hz]
0-6*	Password	1-56	U/f Characteristic - F	2-19	Over-voltage Gain	3-70	Ramp 4 Type	5-*	Digital In/Out
0-60	Main Menu Password	1-58	Flystart Test Pulses Current	2-2*	Mechanical Brake	3-71	Ramp 4 Ramp up Time	5-0*	Digital I/O mode
0-61	Access to Main Menu w/o Password	1-59	Flystart Test Pulses Frequency	2-20	Release Brake Current	3-72	Ramp 4 Ramp Down Time	5-00	Digital I/O Mode
0-65	Quick Menu Password	1-6*	Load Depen. Setting	2-21	Activate Brake Speed [RPM]	3-75	Ramp 4 S-ramp Ratio at Accel. Start	5-01	Terminal 27 Mode
0-66	Access to Quick Menu w/o Password	1-60	Low Speed Load Compensation	2-22	Activate Brake Speed [Hz]	3-76	Ramp 4 S-ramp Ratio at Accel. End	5-02	Terminal 29 Mode
0-67	Bus Password Access	1-61	High Speed Load Compensation	2-23	Activate Brake Delay	3-77	Ramp 4 S-ramp Ratio at Decel. Start	5-1*	Digital Inputs
0-68	Safety Parameters Password	1-62	Slip Compensation	2-24	Stop Delay	3-78	Ramp 4 S-ramp Ratio at Decel. End	5-10	Terminal 18 Digital Input
0-69	Password Protection of Safety Parameters	1-63	Slip Compensation Time Constant	2-25	Brake Release Time	3-8*	Other Ramps	5-11	Terminal 19 Digital Input
1-*	Load and Motor	1-64	Resonance Dampening Time Constant	2-26	Torque Ref	3-80	Jog Ramp Time	5-12	Terminal 27 Digital Input
1-0*	General Settings	1-65	Resonance Dampening Time Constant	2-27	Torque Ramp Time	3-81	Quick Stop Ramp Type	5-13	Terminal 29 Digital Input
1-00	Configuration Mode	1-66	Min. Current at Low Speed	2-28	Gain Boost Factor	3-82	Quick Stop Ramp Type	5-14	Terminal 32 Digital Input
1-01	Motor Control Principle	1-67	Load Type	2-29	Torque Ramp Down Time	3-83	Quick Stop S-ramp Ratio at Decel. Start	5-15	Terminal 33 Digital Input
1-02	Flux Motor Feedback Source	1-68	Minimum Inertia	2-30	Position P Start Proportional Gain	3-84	Quick Stop S-ramp Ratio at Decel. End	5-16	Terminal X30/2 Digital Input
1-03	Torque Characteristics	1-69	Maximum Inertia	2-31	Speed PID Start Proportional Gain	3-9*	Digital Pot.Meter	5-17	Terminal X30/3 Digital Input
1-04	Overload Mode	1-7*	Start Adjustments	2-32	Speed PID Start Integral Time	3-90	Step Size	5-18	Terminal X30/4 Digital Input
1-05	Local Mode Configuration	1-70	PM Start Mode	2-33	Speed PID Start Lowpass Filter Time	3-91	Ramp Time	5-19	Terminal 37 Safe Stop
1-06	Clockwise Direction	1-71	Start Delay	3-*	Reference / Ramps	3-92	Power Restore	5-20	Terminal X46/1 Digital Input
1-07	Motor Angle Offset Adjust	1-72	Start Function	3-0*	Reference Limits	3-93	Maximum Limit	5-21	Terminal X46/3 Digital Input
1-1*	Special Settings	1-73	Flying Start	3-00	Reference Range	3-94	Minimum Limit	5-22	Terminal X46/5 Digital Input
1-10	Motor Construction	1-74	Start Speed [RPM]	3-01	Reference/Feedback Unit	3-95	Ramp Delay	5-23	Terminal X46/7 Digital Input
		1-75	Start Speed [Hz]	3-02	Minimum Reference	4-*	Limits / Warnings	5-24	Terminal X46/9 Digital Input

5-25	Terminal X46/11 Digital Input	6-24	Terminal 54 Low Ref./Feedb. Value	7-31	Process PID Anti Windup	8-52	DC Brake Select	10-11	Process Data Config Write
5-26	Terminal X46/13 Digital Input	6-25	Terminal 54 High Ref./Feedb. Value	7-32	Process PID Start Speed	8-53	Start Select	10-12	Process Data Config Read
5-3*	Digital Outputs	6-26	Terminal 54 Filter Time Constant	7-33	Process PID Proportional Gain	8-54	Reversing Select	10-13	Warning Parameter
5-30	Terminal 27 Digital Output	6-3*	Analog Input 3	7-34	Process PID Integral Time	8-55	Set-up Select	10-14	Net Reference
5-31	Terminal 29 Digital Output	6-30	Terminal X30/11 Low Voltage	7-35	Process PID Differentiation Time	8-56	Preset Reference Select	10-15	Net Control
5-32	Term X30/6 Digi Out (MCB 101)	6-31	Terminal X30/11 High Voltage	7-36	Process PID Diff. Gain Limit	8-57	Profidrive OFF2 Select	10-2*	COS Filters
5-33	Term X30/7 Digi Out (MCB 101)	6-34	Term. X30/11 Low Ref./Feedb. Value	7-38	Process PID Feed Forward Factor	8-58	Profidrive OFF3 Select	10-20	COS Filter 1
5-4*	Relays	6-35	Term. X30/11 High Ref./Feedb. Value	7-39	On Reference Bandwidth	8-8*	FC Port Diagnostics	10-21	COS Filter 2
5-40	Function Relay	6-36	Term. X30/11 Filter Time Constant	7-4*	Adv. Process PID I	8-80	Bus Message Count	10-22	COS Filter 3
5-41	On Delay, Relay	6-4*	Analog Input 4	7-40	Process PID I-part Reset	8-81	Bus Error Count	10-23	COS Filter 4
5-42	Off Delay, Relay	6-40	Terminal X30/12 Low Voltage	7-41	Process PID Output Neg. Clamp	8-82	Slave Messages Rcvd	10-3*	Parameter Access
5-5*	Pulse Input	6-41	Terminal X30/12 High Voltage	7-42	Process PID Output Pos. Clamp	8-83	Slave Error Count	10-30	Array Index
5-50	Term. 29 Low Frequency	6-44	Term. X30/12 Low Ref./Feedb. Value	7-43	Process PID Gain Scale at Min. Ref.	8-9*	Bus Jog	10-31	Store Data Values
5-51	Term. 29 High Frequency	6-45	Term. X30/12 High Ref./Feedb. Value	7-44	Process PID Gain Scale at Max. Ref.	8-90	Bus Jog 1 Speed	10-32	DeviceNet Revision
5-52	Term. 29 Low Ref./Feedb. Value	6-46	Term. X30/12 Filter Time Constant	7-45	Process PID Feed Fwd Resource	8-91	Bus Jog 2 Speed	10-33	Store Always
5-53	Term. 29 High Ref./Feedb. Value	6-5*	Analog Output 1	7-46	Process PID Feed Fwd Normal/ Inv. Ctrl.	9-0*	PROFIDRIVE	10-34	DeviceNet Product Code
5-54	Pulse Filter Time Constant #29	6-50	Terminal 42 Output	7-48	PCD Feed Forward	9-00	Setpoint	10-39	DeviceNet F Parameters
5-55	Term. 33 Low Frequency	6-51	Terminal 42 Output Min Scale	7-49	Process PID Output Normal/ Inv. Ctrl.	9-07	Actual Value	10-5*	CANopen
5-56	Term. 33 High Frequency	6-52	Terminal 42 Output Max Scale	7-5*	Adv. Process PID II	9-15	PCD Write Configuration	10-50	Process Data Config Write.
5-57	Term. 33 Low Ref./Feedb. Value	6-53	Term 42 Output Bus Ctrl	7-50	Process PID Extended PID	9-16	PCD Read Configuration	10-51	Process Data Config Read.
5-58	Term. 33 High Ref./Feedb. Value	6-54	Terminal 42 Output Timeout Preset	7-51	Process PID Feed Fwd Gain	9-18	Node Address	12-2*	Ethernet
5-59	Pulse Filter Time Constant #33	6-55	Analog Output Filter	7-52	Process PID Feed Fwd Ramp up	9-22	Telegram Selection	12-0*	IP Settings
5-6*	Pulse Output	6-6*	Analog Output 2	7-53	Process PID Feed Fwd Ramp down	9-23	Parameters for Signals	12-00	IP Address Assignment
5-60	Terminal 27 Pulse Output Variable	6-60	Terminal X30/8 Output	7-55	Process PID Feed Fwd Ramp down	9-27	Parameter Edit	12-01	IP Address
5-62	Pulse Output Max Freq #27	6-61	Terminal X30/8 Min. Scale	7-56	Process PID Fb. Filter Time	9-28	Process Control	12-02	Subnet Mask
5-63	Terminal 29 Pulse Output Variable	6-62	Terminal X30/8 Max. Scale	7-57	Process PID Fb. Filter Time	9-44	Fault Message Counter	12-03	Default Gateway
5-65	Pulse Output Max Freq #29	6-63	Terminal X30/8 Bus Control	8-3*	Comm. and Options	9-45	Fault Code	12-04	DHCP Server
5-66	Terminal X30/6 Pulse Output Variable	6-64	Terminal X30/8 Output Timeout Preset	8-0*	General Settings	9-47	Fault Number	12-05	Lease Expires
5-68	Pulse Output Max Freq #X30/6	6-7*	Analog Output 3	8-01	Control Site	9-52	Fault Situation Counter	12-06	Name Servers
5-7*	24V Encoder Input	6-70	Terminal X45/1 Output	8-02	Control Word Source	9-53	Profibus Warning Word	12-07	Domain Name
5-70	Term 32/33 Pulses Per Revolution	6-71	Terminal X45/1 Min. Scale	8-03	Control Word Timeout Time	9-63	Actual Baud Rate	12-08	Host Name
5-71	Term 32/33 Encoder Direction	6-72	Terminal X45/1 Max. Scale	8-04	Control Word Timeout Function	9-64	Device Identification	12-09	Physical Address
5-8*	I/O Options	6-73	Terminal X45/1 Bus Control	8-05	End-of-Timeout Function	9-65	Profile Number	12-10	Ethernet Link Parameters
5-80	AHF Cap Reconnect Delay	6-74	Terminal X45/1 Output Timeout Preset	8-06	Reset Control Word Timeout	9-67	Control Word 1	12-10	Link Status
5-9*	Bus Controlled	6-7*	Analog Output 4	8-07	Diagnosis Trigger	9-68	Status Word 1	12-11	Link Duration
5-90	Digital & Relay Bus Control	6-80	Terminal X45/3 Output	8-08	Readout Filtering	9-71	Profibus Save Data Values	12-12	Auto Negotiation
5-93	Pulse Out #27 Bus Control	6-81	Terminal X45/3 Min. Scale	8-1*	Ctrl. Word Settings	9-72	ProfibusDriveReset	12-13	Link Speed
5-94	Pulse Out #27 Timeout Preset	6-82	Terminal X45/3 Max. Scale	8-10	Control Word Profile	9-75	DO Identification	12-14	Link Duplex
5-95	Pulse Out #29 Bus Control	6-83	Terminal X45/3 Bus Control	8-13	Configurable Status Word STW	9-80	Defined Parameters (1)	12-2*	Process Data
5-96	Pulse Out #29 Timeout Preset	6-84	Terminal X45/3 Output Timeout Preset	8-14	Configurable Control Word CTW	9-81	Defined Parameters (2)	12-20	Control Instance
5-97	Pulse Out #X30/6 Bus Control	7-2*	Controllers	8-17	Configurable Alarm and Warning Word	9-82	Defined Parameters (3)	12-21	Process Data Config Write
5-98	Pulse Out #X30/6 Timeout Preset	7-0*	Speed PID Ctrl.	8-19	Product Code	9-83	Defined Parameters (4)	12-22	Process Data Config Read
6-0*	Analog I/O Mode	7-00	Speed PID Feedback Source	8-3*	FC Port Settings	9-84	Defined Parameters (5)	12-23	Process Data Config Write Size
6-00	Live Zero Timeout Time	7-02	Speed PID Proportional Gain	8-30	Protocol	9-90	Changed Parameters (1)	12-24	Process Data Config Read Size
6-01	Live Zero Timeout Function	7-03	Speed PID Integral Time	8-31	Address	9-91	Changed Parameters (2)	12-27	Master Address
6-1*	Analog Input 1	7-04	Speed PID Differentiation Time	8-32	FC Port Baud Rate	9-92	Changed Parameters (3)	12-28	Store Data Values
6-10	Terminal 53 Low Voltage	7-05	Speed PID Diff. Gain Limit	8-33	Parity / Stop Bits	9-93	Changed Parameters (4)	12-29	Store Always
6-11	Terminal 53 High Voltage	7-06	Speed PID Lowpass Filter Time	8-34	Estimated cycle time	9-94	Changed Parameters (5)	12-3*	EtherNet/IP
6-12	Terminal 53 Low Current	7-07	Speed PID Feedback Gear Ratio	8-35	Minimum Response Delay	9-99	Profibus Revision Counter	12-30	Warning Parameter
6-13	Terminal 53 High Current	7-08	Speed PID Feed Forward Factor	8-36	Max Response Delay	10-0*	CAN Fields	12-31	Net Reference
6-14	Terminal 53 High Ref./Feedb. Value	7-1*	Torque PI Ctrl.	8-37	Max Inter-Char Delay	10-00	Common Settings	12-32	Net Control
6-15	Terminal 53 High Ref./Feedb. Value	7-12	Torque PI Proportional Gain	8-40	Telegram Selection	10-01	CAN Protocol	12-33	CIP Revision
6-16	Terminal 53 Filter Time Constant	7-13	Torque PI Integration Time	8-41	Parameters for Signals	10-02	MAC ID	12-34	CIP Product Code
6-2*	Analog Input 2	7-2*	Process Ctrl. Feedb	8-42	PCD Write Configuration	10-05	Readout Transmit Error Counter	12-35	EDS Parameter
6-20	Terminal 54 Low Voltage	7-20	Process CL Feedback 1 Resource	8-43	PCD Read Configuration	10-06	Readout Receive Error Counter	12-37	COS Inhibit Timer
6-21	Terminal 54 High Voltage	7-22	Process CL Feedback 2 Resource	8-5*	Digital/Bus	10-07	Readout Bus Off Counter	12-38	COS Filter
6-22	Terminal 54 Low Current	7-3*	Process PID Ctrl.	8-50	Coasting Select	10-1*	DeviceNet	12-40	Status Parameter
6-23	Terminal 54 High Current	7-30	Process PID Normal/ Inverse Control	8-51	Quick Stop Select	10-10	Process Data Type Selection	12-41	Slave Message Count

12-42	Slave Exception Message Count	15-14	Samples Before Trigger	16-13	Frequency	16-82	Fieldbus REF 1
12-5*	EtherCAT	15-2*	Historic Log	16-14	Motor current	16-84	Comm. Option STW
12-50	Configured Station Alias	15-20	Historic Log: Event	16-15	Frequency [%]	16-85	FC Port CTW 1
12-51	Configured Station Address	15-21	Historic Log: Value	16-16	Torque [Nm]	16-86	FC Port REF 1
12-59	EtherCAT Status	15-22	Historic Log: Time	16-17	Speed [RPM]	16-87	Bus Readout Alarm/Warning
12-6*	Ethernet PowerLink	15-3*	Fault Log	16-18	Motor Thermal	16-89	Configurable Alarm/Warning Word
12-60	Node ID	15-30	Fault Log: Error Code	16-19	KTY sensor temperature	16-9*	Diagnosis Readouts
12-62	SDO Timeout	15-31	Fault Log: Value	16-20	Motor Angle	16-90	Alarm Word
12-63	Basic Ethernet Timeout	15-32	Fault Log: Time	16-21	Torque [%] High Res.	16-91	Alarm Word 2
12-66	Threshold	15-4*	Drive Identification	16-22	Torque [%]	16-92	Warning Word
12-67	Threshold Counters	15-40	FC Type	16-23	Motor Shaft Power [kW]	16-93	Warning Word 2
12-68	Cumulative Counters	15-41	Power Section	16-24	Calibrated Stator Resistance	16-94	Ext. Status Word
12-69	Ethernet PowerLink Status	15-42	Voltage	16-25	Torque [Nm] High	17-1*	Feedback Option
12-8*	Other Ethernet Services	15-43	Software Version	16-3*	Drive Status	17-1*	Inc. Enc. Interface
12-80	FTP Server	15-44	Ordered Typecode String	16-30	DC Link Voltage	17-10	Signal Type
12-81	HTTP Server	15-45	Actual Typecode String	16-32	Brake Energy /s	17-11	Resolution (PPR)
12-82	SMTP Service	15-46	Frequency Converter Ordering No	16-33	Brake Energy /2 min	17-2*	Abs. Enc. Interface
12-89	Transparent Socket Channel Port	15-47	Power Card Ordering No	16-34	Heatsink Temp.	17-20	Protocol Selection
12-9*	Advanced Ethernet Services	15-48	LCP Id No	16-35	Inverter Thermal	17-21	Resolution (Positions/Rev)
12-90	Cable Diagnostic	15-49	SW ID Control Card	16-36	Inv. Nom. Current	17-24	SSI Data Length
12-91	Auto Cross Over	15-50	SW ID Power Card	16-37	Inv. Max. Current	17-25	Clock Rate
12-92	IGMP Snooping	15-51	Frequency Converter Serial Number	16-38	SL Controller State	17-26	SSI Data Format
12-93	Cable Error Length	15-53	Power Card Serial Number	16-39	Control Card Temp.	17-34	HIPERFACE Baudrate
12-94	Broadcast Storm Protection	15-58	Smart Setup Filename	16-40	Logging Buffer Full	17-5*	Resolver Interface
12-95	Broadcast Storm Filter	15-59	CSIV Filename	16-41	LCP Bottom Statusline	17-50	Poles
12-96	Port Config	15-6*	Option Ident	16-45	Motor Phase U Current	17-51	Input Voltage
12-98	Interface Counters	15-60	Option Mounted	16-46	Motor Phase V Current	17-52	Input Frequency
12-99	Media Counters	15-61	Option SW Version	16-47	Motor Phase W Current	17-53	Transformation Ratio
13-0*	Smart Logic	15-62	Option Ordering No	16-48	Speed Ref. After Ramp [RPM]	17-56	Encoder Sim. Resolution
13-0*	SLC Settings	15-63	Option Serial No	16-49	Current Fault Source	17-59	Resolver Interface
13-00	SL Controller Mode	15-70	Option in Slot A	16-5*	Ref. & Feeds.	17-6*	Monitoring and App.
13-01	Start Event	15-71	Slot A Option SW Version	16-50	External Reference	17-60	Feedback Direction
13-02	Stop Event	15-72	Option in Slot B	16-51	Pulse Reference	17-61	Feedback Signal Monitoring
13-03	Reset SLC	15-73	Slot B Option SW Version	16-52	Feedback[Unit]	18-*	Data Readouts 2
13-1*	Comparators	15-74	Option in Slot C0/E0	16-53	Digi Pot Reference	18-3*	Analog Readouts
13-10	Comparator Operand	15-75	Slot C0/E0 Option SW Version	16-57	Feedback [RPM]	18-36	Analog Input X48/2 [mA]
13-11	Comparator Operator	15-76	Option in Slot C1/E1	16-6*	Inputs & Outputs	18-37	Temp. Input X48/4
13-12	Comparator Value	15-77	Slot C1/E1 Option SW Version	16-60	Digital Input	18-38	Temp. Input X48/7
13-1*	RS Flip Flops	15-8*	Operating Data II	16-61	Terminal 53 Switch Setting	18-39	Temp. Input X48/10
13-15	RS-FF Operand S	15-80	Fan Running Hours	16-62	Analog Input 53	18-6*	Inputs & Outputs 2
13-16	RS-FF Operand R	15-81	Preset Fan Running Hours	16-63	Terminal 54 Switch Setting	18-60	Digital Input 2
13-2*	Timers	15-89	Configuration Change Counter	16-64	Analog Input 54	18-9*	PID Readouts
13-20	SL Controller Timer	15-92	Defined Parameters	16-65	Analog Output 42 [mA]	18-90	Process PID Error
13-4*	Logic Rules	15-93	Modified Parameters	16-66	Digital Output [bin]	18-91	Process PID Output
13-40	Logic Rule Boolean 1	15-98	Drive Identification	16-67	Freq. Input #29 [Hz]	18-92	Process PID Clamped Output
13-41	Logic Rule Operator 1	15-99	Parameter Metadata	16-68	Freq. Input #33 [Hz]	18-93	Process PID Gain Scaled Output
13-42	Logic Rule Boolean 2	16-*	Data Readouts	16-69	Pulse Output #27 [Hz]	30-*	Special Features
13-43	Logic Rule Operator 2	16-0*	General Status	16-70	Pulse Output #29 [Hz]	30-0*	Wobbler
13-44	Logic Rule Boolean 3	16-00	Control Word	16-71	Relay Output [bin]	30-00	Wobble Mode
13-5*	States	16-01	Reference [Unit]	16-72	Counter A	30-01	Wobble Delta Frequency [Hz]
13-51	SL Controller Event	16-02	Reference %	16-73	Counter B	30-02	Wobble Delta Frequency [%]
13-52	SL Controller Action	16-03	Status Word	16-74	Prec. Stop Counter	30-03	Wobble Delta Freq. Scaling Resource
14-0*	Special Functions	16-05	Main Actual Value [%]	16-75	Analog in X30/11	30-04	Wobble Jump Frequency [Hz]
14-0*	Inverter Switching	16-09	Custom Readout	16-76	Analog in X30/12	30-05	Wobble Jump Frequency [%]
14-00	Switching Pattern	16-1*	Motor Status	16-77	Analog Out X30/8 [mA]	30-06	Wobble Jump Time
14-01	Switching Frequency	16-10	Logging Source	16-78	Analog Out X45/1 [mA]	30-07	Wobble Sequence Time
14-03	Overmodulation	16-11	Power [kW]	16-79	Analog Out X45/3 [mA]	30-08	Wobble Up/ Down Time
14-04	PWM Random	16-12	Motor Voltage	16-8*	Fieldbus & FC Port	30-09	Wobble Random Function
14-06	Dead Time Compensation			16-80	Fieldbus CTW 1	30-10	Wobble Ratio

30-11	Wobble Random Ratio Max.	33-31	Synchronisation Type	34-08	PCD 8 Write to MCO	35-37	Term. X48/10 High Temp. Limit
30-12	Wobble Random Ratio Min.	33-32	Feed Forward Velocity Adaptation	34-09	PCD 9 Write to MCO	35-4*	Analog Input X48/2
30-19	Wobble Delta Freq. Scaled	33-33	Velocity Filter Window	34-10	PCD 10 Write to MCO	35-42	Term. X48/2 Low Current
30-2*	Adv. Start Adjust	33-34	Slave Marker filter time	34-2*	PCD Read Par.	35-43	Term. X48/2 High Current
30-20	High Starting Torque Time [s]	33-4*	Limit Handling	34-21	PCD 1 Read from MCO	35-44	Term. X48/2 Low Ref./Feedb. Value
30-21	High Starting Torque Current [%]	33-40	Behaviour at End Limit Switch	34-22	PCD 2 Read from MCO	35-45	Term. X48/2 High Ref./Feedb. Value
30-22	Locked Rotor Protection	33-41	Negative Software End Limit	34-23	PCD 3 Read from MCO	35-46	Term. X48/2 Filter Time Constant
30-23	Locked Rotor Detection Time [s]	33-42	Positive Software End Limit	34-24	PCD 4 Read from MCO	42-*	Safety Functions
30-24	Locked Rotor Detection Speed Error [%]	33-43	Negative Software End Limit Active	34-25	PCD 5 Read from MCO	42-1*	Speed Monitoring
30-8*	Compatibility (I)	33-44	Reverse Software End Limit Active	34-26	PCD 6 Read from MCO	42-10	Measured Speed Source
30-80	d-axis Inductance (Ld)	33-45	Time in Target Window	34-27	PCD 7 Read from MCO	42-11	Encoder Resolution
30-81	Brake Resistor (ohm)	33-46	Target Window Limit/Value	34-28	PCD 8 Read from MCO	42-12	Encoder Direction
30-83	Speed PID Proportional Gain	33-47	Size of Target Window	34-29	PCD 9 Read from MCO	42-13	Gear Ratio
30-84	Process PID Proportional Gain	33-5*	I/O Configuration	34-30	PCD 10 Read from MCO	42-14	Feedback Type
31-00	Bypass Option	33-50	Terminal X57/1 Digital Input	34-4*	Inputs & Outputs	42-15	Feedback Filter
31-01	Bypass Start Time Delay	33-51	Terminal X57/2 Digital Input	34-40	Digital Inputs	42-17	Tolerance Error
31-02	Bypass Trip Time Delay	33-52	Terminal X57/3 Digital Input	34-41	Digital Outputs	42-18	Zero Speed Timer
31-03	Test Mode Activation	33-53	Terminal X57/4 Digital Input	34-5*	Process Data	42-19	Zero Speed Limit
31-10	Bypass Status Word	33-54	Terminal X57/5 Digital Input	34-50	Actual Position	42-20	Safe Input
31-11	Bypass Running Hours	33-55	Terminal X57/6 Digital Input	34-51	Commanded Position	42-21	Type
31-19	Remote Bypass Activation	33-56	Terminal X57/7 Digital Input	34-52	Actual Master Position	42-22	Discrepancy Time
32-*	MCO Basic Settings	33-57	Terminal X57/8 Digital Input	34-53	Slave Index Position	42-23	Stable Signal Time
32-0*	Encoder 2	33-58	Terminal X57/9 Digital Input	34-54	Master Index Position	42-24	Restart Behaviour
32-00	Incremental Signal Type	33-59	Terminal X57/10 Digital Input	34-55	Curve Position	42-3*	General
32-01	Incremental Resolution	33-60	Terminal X59/1 Digital Input	34-56	Track Error	42-30	External Failure Reaction
32-02	Absolute Protocol	33-61	Terminal X59/2 Digital Input	34-57	Synchronizing Error	42-31	Reset Source
32-03	Absolute Resolution	33-62	Terminal X59/3 Digital Input	34-58	Actual Velocity	42-33	Parameter Set Name
32-04	Absolute Encoder Baudrate X55	33-63	Terminal X59/4 Digital Input	34-59	Actual Master Velocity	42-35	S-CRC Value
32-05	Absolute Encoder Data Length	33-64	Terminal X59/5 Digital Output	34-60	Synchronizing Status	42-36	Level 1 Password
32-06	Absolute Encoder Clock Frequency	33-65	Terminal X59/6 Digital Output	34-61	Axis Status	42-4*	SS1
32-07	Absolute Encoder Clock Generation	33-66	Terminal X59/7 Digital Output	34-62	Program Status	42-40	Type
32-08	Absolute Encoder Cable Length	33-67	Terminal X59/8 Digital Output	34-64	MCO 302 Status	42-41	Ramp Profile
32-09	Encoder Monitoring	33-68	Terminal X59/9 Digital Output	34-65	MCO 302 Control	42-42	Delay Time
32-10	Rotational Direction	33-69	Terminal X59/10 Digital Output	34-70	MCO Alarm Word 1	42-43	Delta T
32-11	User Unit Denominator	33-70	Terminal X59/11 Digital Output	34-71	MCO Alarm Word 2	42-44	Deceleration Rate
32-12	User Unit Numerator	33-8*	Global Parameters	35-*	Sensor Input Option	42-45	Delta V
32-13	Enc.2 Control	33-80	Activated Program Number	35-0*	Temp. Input Mode	42-46	Zero Speed
32-14	Enc.2 node ID	33-81	Power-up State	35-00	Term. X48/4 Temperature Unit	42-47	Ramp Time
32-15	Enc.2 CAN guard	33-82	Drive Status Monitoring	35-01	Term. X48/4 Input Type	42-48	S-ramp Ratio at Decel. Start
32-3*	Encoder 1	33-83	Behaviour afterError	35-02	Term. X48/7 Temperature Unit	42-49	S-ramp Ratio at Decel. End
32-30	Incremental Signal Type	33-84	Behaviour afterEsc.	35-03	Term. X48/7 Input Type	42-5*	SL5
32-31	Incremental Resolution	33-85	MCO Supplied by External 24VDC	35-04	Term. X48/10 Temperature Unit	42-50	Cut Off Speed
32-32	Absolute Protocol	33-86	Terminal state at alarm	35-05	Term. X48/10 Input Type	42-51	Speed Limit
32-33	Absolute Resolution	33-87	Terminal state at alarm	35-06	Temperature Sensor Alarm Function	42-52	Fail Safe Reaction
32-35	Absolute Encoder Data Length	33-9*	MCO Port Settings	35-1*	Temp. Input X48/4	42-53	Start Ramp
32-36	Absolute Encoder Clock Frequency	33-90	X62 MCO CAN node ID	35-14	Term. X48/4 Filter Time Constant	42-54	Ramp Down Time
32-37	Absolute Encoder Clock Generation	33-91	X62 MCO CAN baud rate	35-15	Term. X48/4 Temp. Monitor	42-8*	Status
32-38	Absolute Encoder Cable Length	33-92	X60 MCO RS485 serial termination	35-16	Term. X48/4 Low Temp. Limit	42-80	Safe Option Status
32-39	Encoder Monitoring	33-93	X60 MCO RS485 serial baud rate	35-17	Term. X48/4 High Temp. Limit	42-81	Safe Option Status 2
32-40	Encoder Termination	34-*	MCO Data Readouts	35-2*	Temp. Input X48/7	42-85	Active Safe Func.
32-43	Enc.1 Control	34-0*	PCD Write Par.	35-24	Term. X48/7 Filter Time Constant	42-86	Safe Option Info
32-44	Enc.1 node ID	34-01	PCD 1 Write to MCO	35-25	Term. X48/7 Temp. Monitor	42-89	Customization File Version
32-45	Enc.1 CAN guard	34-02	PCD 2 Write to MCO	35-26	Term. X48/7 Low Temp. Limit	42-9*	Special
32-5*	Feedback Source	34-03	PCD 3 Write to MCO	35-27	Term. X48/7 High Temp. Limit	42-90	Restart Safe Option
32-50	Source Slave	34-04	PCD 4 Write to MCO	35-3*	Temp. Input X48/10		
32-51	MCO 302 Last Will	34-05	PCD 5 Write to MCO	35-34	Term. X48/10 Filter Time Constant		
32-52	Source Master	34-06	PCD 6 Write to MCO	35-35	Term. X48/10 Temp. Monitor		
		34-07	PCD 7 Write to MCO	35-36	Term. X48/10 Low Temp. Limit		



6.6 Remote Programming with MCT 10 Set-up Software

Danfoss has a software program available for developing, storing, and transferring frequency converter programming. The MCT 10 Set-up Software allows the user to connect a PC to the frequency converter and perform live programming rather than using the LCP. Additionally, all frequency converter programming can be done off-line and simply downloaded to the frequency converter. Or the entire frequency converter profile can be loaded onto the PC for back-up storage or analysis.

The USB connector or RS-485 terminal are available for connecting the PC to the frequency converter.

7 Application Examples

7.1 Introduction

The examples in this section are intended as a quick reference for common applications.

- Parameter settings are the regional default values unless otherwise indicated (selected in *0-03 Regional Settings*).
- Parameters associated with the terminals and their settings are shown next to the drawings.
- Where switch settings for analog terminals A53 or A54 are required, these are also shown.

7.2 Application Examples



Thermistors must use reinforced or double insulation to meet PELV insulation requirements.

		Parameters	
FC		Function	Setting
+24 V	12	1-29 Automatic Motor Adaptation (AMA)	[1] Enable complete AMA
+24 V	13		
D IN	18	5-12 Terminal 27 Digital Input	[2]* Coast inverse
D IN	19		
COM	20	*=Default Value	
D IN	27	Notes/comments: Parameter group 1-2* Motor Data must be set according to motor	
D IN	29		
D IN	32		
D IN	33		
D IN	37		
+10 V	50		
A IN	53		
A IN	54		
COM	55		
A OUT	42		
COM	39		

Table 7.1 AMA with T27 Connected

		Parameters	
FC		Function	Setting
+24 V	12	1-29 Automatic Motor Adaptation (AMA)	[1] Enable complete AMA
+24 V	13		
D IN	18	5-12 Terminal 27 Digital Input	[0] No operation
D IN	19		
COM	20	*=Default Value	
D IN	27	Notes/comments: Parameter group 1-2* Motor Data must be set according to motor	
D IN	29		
D IN	32		
D IN	33		
D IN	37		
+10 V	50		
A IN	53		
A IN	54		
COM	55		
A OUT	42		
COM	39		

Table 7.2 AMA without T27 Connected

		Parameters	
FC		Function	Setting
+24 V	12	6-10 Terminal 53 Low Voltage	0.07 V*
+24 V	13		
D IN	18	6-11 Terminal 53 High Voltage	10 V*
D IN	19		
COM	20	6-14 Terminal 53 Low Ref./Feedb. Value	0 RPM
D IN	27		
D IN	29	6-15 Terminal 53 High Ref./Feedb. Value	1,500 RPM
D IN	32		
D IN	33	*=Default Value	
D IN	37	Notes/comments:	
+10 V	50		
A IN	53		
A IN	54		
COM	55		
A OUT	42		
COM	39		

Table 7.3 Analog Speed Reference (Voltage)

		Parameters	
FC		Function	Setting
+24 V	12	6-12 Terminal 53	4 mA*
+24 V	13	Low Current	
D IN	18	6-13 Terminal 53	20 mA*
D IN	19	High Current	
COM	20	6-14 Terminal 53	0 RPM
D IN	27	Low Ref./Feedb. Value	
D IN	29	6-15 Terminal 53	1,500 RPM
D IN	32	High Ref./Feedb. Value	
D IN	33		
D IN	37		
*=-Default Value			
Notes/comments:			

Table 7.4 Analog Speed Reference (Current)

		Parameters	
FC		Function	Setting
+24 V	12	5-10 Terminal 18	[8] Start*
+24 V	13	Digital Input	
D IN	18	5-12 Terminal 27	[0] No operation
D IN	19	Digital Input	
COM	20	5-19 Terminal 37	[1] Safe Stop Alarm
D IN	27	Digital Input	
D IN	29		
D IN	32		
D IN	33		
D IN	37		
*=-Default Value			
Notes/comments:			

Table 7.5 Start/Stop Command with Safe Torque Off

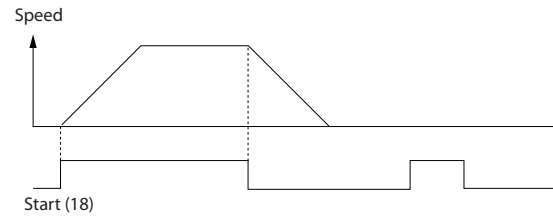

Illustration 7.1 Start/Stop with Safe Torque Off

		Parameters	
FC		Function	Setting
+24 V	12	5-10 Terminal 18	[9] Latched Digital Input
+24 V	13	Digital Input	Start
D IN	18	5-12 Terminal 27	[6] Stop Digital Input
D IN	19	Digital Input	Inverse
COM	20		
*=-Default Value			
Notes/comments:			

Table 7.6 Pulse Start/Stop

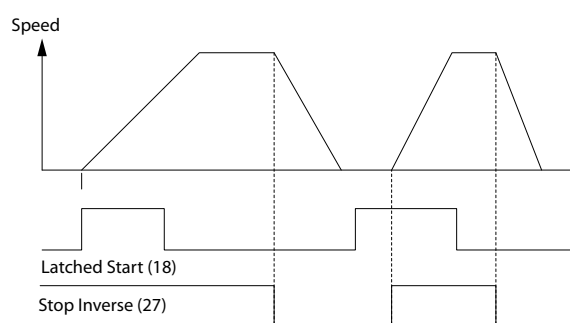

Illustration 7.2 Latched Start/Stop Inverse

7

		Parameters	
FC		Function	Setting
+24 V	12	5-10 Terminal 18	[8] Start
+24 V	13	Digital Input	
D IN	18	5-11 Terminal 19	[10] Reversing*
D IN	19	Digital Input	
COM	20		
D IN	27	5-12 Terminal 27	[0] No operation
D IN	29	Digital Input	
D IN	32	5-14 Terminal 32	[16] Preset ref bit 0
D IN	33	Digital Input	
D IN	37	5-15 Terminal 33	[17] Preset ref bit 1
+10 V	50	Digital Input	
A IN	53	3-10 Preset Reference	
A IN	54	Preset ref. 0	25%
COM	55	Preset ref. 1	50%
A OUT	42	Preset ref. 2	75%
COM	39	Preset ref. 3	100%
		* = Default Value	
		Notes/comments:	

Table 7.7 Start/Stop with Reversing and 4 Preset Speeds

		Parameters	
FC		Function	Setting
+24 V	12	5-11 Terminal 19	[1] Reset
+24 V	13	Digital Input	
D IN	18	* = Default Value	
D IN	19	Notes/comments:	
COM	20		
D IN	27		
D IN	29		
D IN	32		
D IN	33		
D IN	37		
+10 V	50		
A IN	53		
A IN	54		
COM	55		
A OUT	42		
COM	39		

Table 7.8 External Alarm Reset

		Parameters	
FC		Function	Setting
+24 V	12	6-10 Terminal 53	0.07 V*
+24 V	13	Low Voltage	
D IN	18	6-11 Terminal 53	10 V*
D IN	19	High Voltage	
COM	20	6-14 Terminal 53	0 RPM
D IN	27	Low Ref./Feedb. Value	
D IN	29	6-15 Terminal 53	1,500 RPM
D IN	32	High Ref./Feedb. Value	
D IN	33	* = Default Value	
D IN	37	Notes/comments:	
+10 V	50		
A IN	53		
A IN	54		
COM	55		
A OUT	42		
COM	39		
		U - I	
		A53	

Table 7.9 Speed Reference (using a Manual Potentiometer)

		Parameters	
FC		Function	Setting
+24 V	12	5-10 Terminal 18	[8] Start*
+24 V	13	Digital Input	
D IN	18	5-12 Terminal 27	[19] Freeze Reference
D IN	19	Digital Input	
COM	20	5-13 Terminal 29	[21] Speed Up
D IN	27	Digital Input	
D IN	29	5-14 Terminal 32	[22] Speed Down
D IN	32	Digital Input	
D IN	33	* = Default Value	
D IN	37	Notes/comments:	
+10 V	50		
A IN	53		
A IN	54		
COM	55		
A OUT	42		
COM	39		

Table 7.10 Speed Up/Down

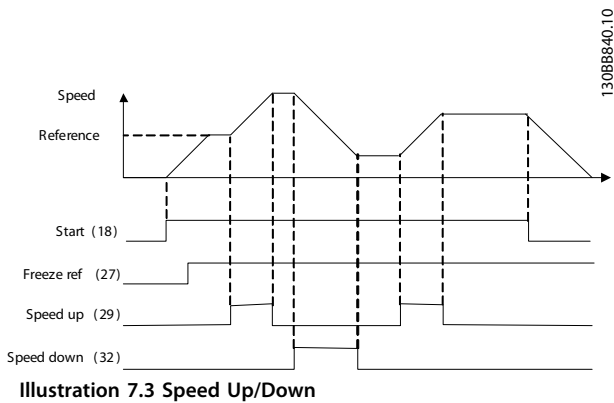

		Parameters	
FC		Function	Setting
+24 V	12	8-30 Protocol	FC*
+24 V	13	8-31 Address	1*
D IN	18	8-32 Baud Rate	9,600*
D IN	19	*=Default Value	
COM	20	Notes/comments:	
D IN	27	Select protocol, address, and	
D IN	29	Baud rate in the above	
D IN	32	mentioned parameters.	
D IN	33		
D IN	37		
+10 V	50		
A IN	53		
A IN	54		
COM	55		
A OUT	42		
COM	39		
R1	01		
	02		
	03		
R2	04		
	05		
	06		
	61		
	68		
	69		
		RS-485	

130BB685.10

Table 7.11 RS-485 Network Connection

		Parameters	
VLT		Function	Setting
+24 V	12	1-90 Motor	[2]
+24 V	13	Thermal	Thermistor
D IN	18	Protection	trip
D IN	19	1-93 Thermistor	[1] Analog
COM	20	Source	input 53
D IN	27	*=Default Value	
D IN	29		
D IN	32		
D IN	33		
D IN	37		
+10 V	50	Notes/comments:	
A IN	53	If only a warning is desired, set	
A IN	54	1-90 Motor Thermal Protection	
COM	55	to [1] Thermistor warning.	
A OUT	42		
COM	39		
		U - I	
		A53	

130BB686.12

Table 7.12 Motor Thermistor

		Parameters	
FC		Function	Setting
+24 V	12	4-30 Motor Feedback Loss Function	[1] Warning
+24 V	13		
D IN	18	4-31 Motor Feedback Speed Error	100 RPM
COM	20		
D IN	27	4-32 Motor Feedback Loss Timeout	5 s
D IN	29		
D IN	32		
D IN	33		
D IN	37		
+10 V	50	7-00 Speed PID Feedback Source	[2] MCB 102
A IN	53	17-11 Resolution (PPR)	1024*
A IN	54	13-00 SL Controller Mode	[1] On
COM	55		
A OUT	42	13-01 Start Event	[19] Warning
COM	39		
RI	01	13-02 Stop Event	[44] Reset key
	02		
	03	13-10 Comparat or Operand	[21] Warning no.
	04	13-11 Comparat or Operator	[1] ≈*
	05	13-12 Comparat or Value	90
	06		
		13-51 SL Controller Event	[22] Comparator 0
		13-52 SL Controller Action	[32] Set digital out A low
		5-40 Function Relay	[80] SL digital output A
		* = Default Value	
		Notes/comments: If the limit in the feedback monitor is exceeded, Warning 90 is issued. The SLC monitors Warning 90 and in the case that Warning 90 becomes TRUE then relay 1 is triggered. External equipment may indicate that service is required. If the feedback error goes below the limit again within 5 s, the frequency converter continues and the warning disappears. But relay 1 is still triggered until [Reset] on the LCP.	

Table 7.13 Using SLC to Set a Relay

		Parameters	
FC		Function	Setting
+24 V	12	1-00 Configuration Mode	[0] Speed open loop
+24 V	13		
D IN	18	1-01 Motor Control Principle	[1] VVC+
D IN	19		
COM	20	5-40 Function Relay	[32] Mech. brake ctrl.
D IN	27		
D IN	29	5-10 Terminal 18 Digital Input	[8] Start*
D IN	32		
D IN	33	5-11 Terminal 19 Digital Input	[11] Start reversing
D IN	37	1-71 Start Delay	0.2
+10 V	50	1-72 Start Function	[5] VVC+/ FLUX Clockwise
A IN	53		
A IN	54		
COM	55		
A OUT	42	1-76 Start Current	$I_{m,n}$
COM	39		
RI	01	2-20 Release Brake Current	App. dependent
	02		
	03	2-21 Activate Brake Speed [RPM]	Half of nominal slip of the motor
	04		
	05		
	06		
		* = Default Value	
		Notes/comments:	

Table 7.14 Mechanical Brake Control (Open Loop)

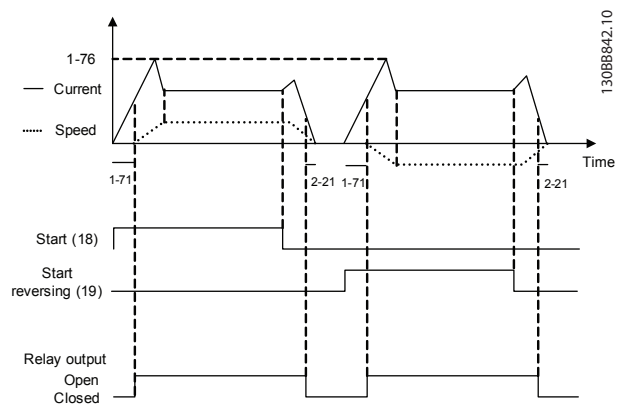

Illustration 7.4 Mechanical Brake Control (Open Loop)

7.3 Connection Examples for Control of Motor with External Signal Provider

NOTICE

The following examples refer only to the frequency converter control card (right LCP), not the filter.

7.3.1 Start/Stop

Terminal 18 = 5-10 Terminal 18 Digital Input [8] Start

Terminal 27 = 5-12 Terminal 27 Digital Input [0] No operation (Default coast inverse)

Terminal 37 = Safe stop

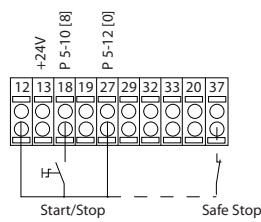

130BA155.12

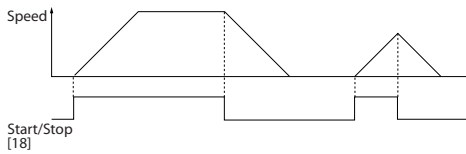

Illustration 7.5 Start/Stop Parameters

7.3.2 Pulse Start/Stop

Terminal 18 = 5-10 Terminal 18 Digital Input [9] Latched start

Terminal 27 = 5-12 Terminal 27 Digital Input [6] Stop inverse

Terminal 37 = Safe torque off

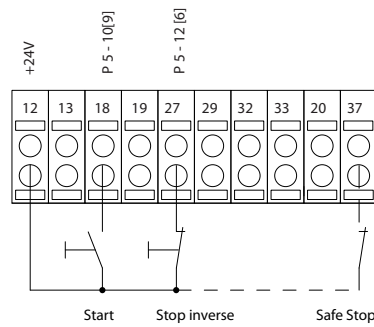

130BA156.12

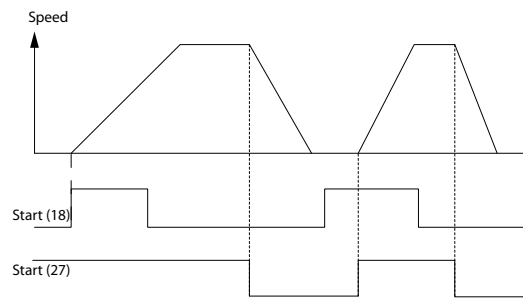

Illustration 7.6 Pulse Start/Stop Parameters

7.3.3 Speed Up/Down

Terminals 29/32 = Speed up/down

Terminal 18 = 5-10 Terminal 18 Digital Input [9] Start (default)

Terminal 27 = 5-12 Terminal 27 Digital Input [19] Freeze reference

Terminal 29 = 5-13 Terminal 29 Digital Input [21] Speed up

Terminal 32 = 5-14 Terminal 32 Digital Input [22] Speed down

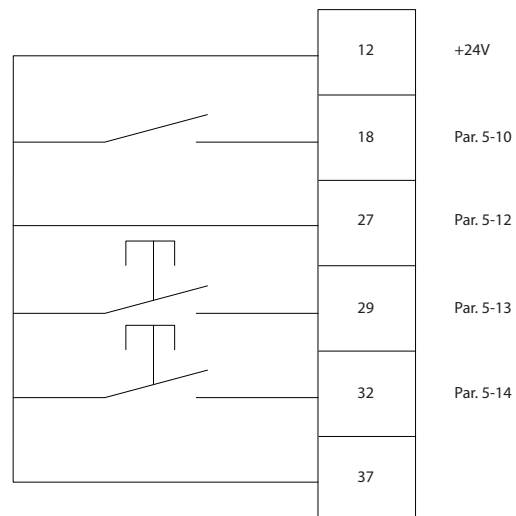

130BA021.12

Illustration 7.7 Speed Control Parameters

7.3.4 Potentiometer Reference

Voltage reference via a potentiometer

Reference Source 1 = [1] Analog input 53 (default)

Voltage reference via potentiometer

Terminal 53, Low Voltage = 0 V

Terminal 53, High Voltage = 10 V

Terminal 53, Low Ref./Feedback = 0 RPM

Terminal 53, High Ref./Feedback = 1500 RPM

Switch S201 = OFF (U)

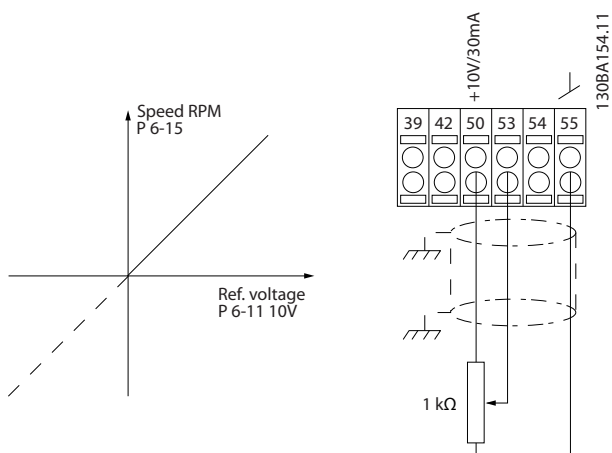
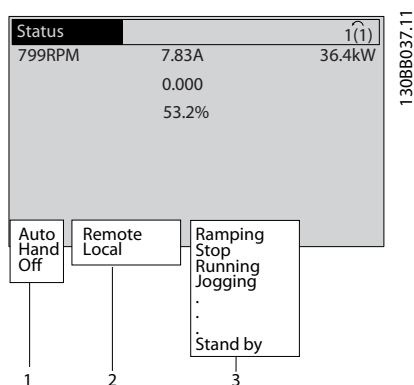

Illustration 7.8 Potentiometer Voltage Reference

8 Status Messages

8.1 Status Display

When the frequency converter is in *Status mode*, status messages are generated automatically and appear in the bottom line of the display (see *Illustration 8.1*).



1	Operation mode (see <i>Table 8.1</i>)
2	Reference site (see <i>Table 8.2</i>)
3	Operation status (see <i>Table 8.3</i>)

Illustration 8.1 Status Display

8.2 Status Message Definitions Table

Table 8.1 to *Table 8.3* describe the displayed status messages.

Off	The frequency converter does not react to any control signal until [Auto On] or [Hand On] is pressed.
Auto On	The frequency converter is controlled from the control terminals and/or the serial communication.
Hand On	Control the unit via the navigation keys on the LCP. Stop commands, reset, reversing, DC brake, and other signals applied to the control terminals can override local control.

Table 8.1 Operation Mode

Remote	The speed reference is given from external signals, serial communication, or internal preset references.
Local	The frequency converter uses [Hand On] control or reference values from the LCP.

Table 8.2 Reference Site

AC Brake	AC Brake was selected in <i>2-10 Brake Function</i> . The AC brake over-magnetises the motor to achieve a controlled slow down.
AMA finish OK	Automatic motor adaptation (AMA) was carried out successfully.
AMA ready	AMA is ready to start. Press [Hand On] to start.
AMA running	AMA process is in progress.
Braking	The brake chopper is in operation. The brake resistor absorbs generative energy.
Braking max.	The brake chopper is in operation. The power limit for the brake resistor has been reached.
Coast	<ul style="list-style-type: none"> Coast inverse was selected as a function for a digital input (parameter group 5-1* <i>Digital Inputs</i>). The corresponding terminal is not connected. Coast activated by serial communication
Ctrl. Ramp-down	Control Ramp-down was selected in <i>14-10 Mains Failure</i> . <ul style="list-style-type: none"> The mains voltage is below the value set in <i>14-11 Mains Voltage at Mains Fault</i> at mains fault The frequency converter ramps down the motor using a controlled ramp down
Current High	The frequency converter output current is above the limit set in <i>4-51 Warning Current High</i> .
Current Low	The frequency converter output current is below the limit set in <i>4-52 Warning Speed Low</i>
DC Hold	DC hold is selected in <i>1-80 Function at Stop</i> and a stop command is active. The motor is held by a DC current set in <i>2-00 DC Hold/Preheat Current</i> .
DC Stop	The motor is held with a DC current (<i>2-01 DC Brake Current</i>) for a specified time (<i>2-02 DC Braking Time</i>). <ul style="list-style-type: none"> DC brake is activated in <i>2-03 DC Brake Cut In Speed [RPM]</i> and a stop command is active. DC brake (inverse) is selected as a function for a digital input (parameter group 5-1* <i>Digital Inputs</i>). The corresponding terminal is not active. The DC brake is activated via serial communication.
Feedback high	The sum of all active feedbacks is above the feedback limit set in <i>4-57 Warning Feedback High</i> .
Feedback low	The sum of all active feedbacks is below the feedback limit set in <i>4-56 Warning Feedback Low</i> .

Freeze output	The remote reference is active, which holds the present speed. <ul style="list-style-type: none"> Freeze output was selected as a function for a digital input (parameter group 5-1* <i>Digital Inputs</i>). The corresponding terminal is active. Speed control is only possible via the terminal functions Speed Up and Speed Down. Hold ramp is activated via serial communication.
Freeze output request	A freeze output command has been given, but the motor remains stopped until a run permissive signal is received.
Freeze ref.	<i>Freeze Reference</i> was selected as a function for a digital input (parameter group 5-1* <i>Digital Inputs</i>). The corresponding terminal is active. The frequency converter saves the actual reference. Changing the reference is now only possible via terminal functions speed up and speed down.
Jog request	A jog command has been given, but the motor remains stopped until a run permissive signal is received via a digital input.
Jogging	The motor is running as programmed in 3-19 <i>Jog Speed [RPM]</i> . <ul style="list-style-type: none"> <i>Jog</i> was selected as function for a digital input (parameter group 5-1* <i>Digital Inputs</i>). The corresponding terminal is active. The jog function is activated via the serial communication. The jog function was selected as a reaction for a monitoring function. The monitoring function is active.
Motor check	In 1-80 <i>Function at Stop, Motor Check</i> was selected. A stop command is active. To ensure that a motor is connected to the frequency converter, a permanent test current is applied to the motor.
OVC control	<i>Overvoltage</i> control was activated in 2-17 <i>Overvoltage Control, [2] Enabled</i> . The connected motor supplies the frequency converter with generative energy. The overvoltage control adjusts the V/Hz ratio to run the motor in controlled mode and to prevent the frequency converter from tripping.
PowerUnit Off	(Only frequency converters with an external 24 V power supply installed). Mains supply to the frequency converter is removed, but the control card is supplied by the external 24 V.

Protection md	Protection mode is active. The unit has detected a critical status (an overcurrent or overvoltage). <ul style="list-style-type: none"> To avoid tripping, the switching frequency is reduced to 4 kHz. If possible, protection mode ends after approximately 10 s. Protection mode can be restricted in 14-26 <i>Trip Delay at Inverter Fault</i>.
QStop	The motor is decelerating using 3-81 <i>Quick Stop Ramp Time</i> . <ul style="list-style-type: none"> <i>Quick stop inverse</i> was selected as a function for a digital input (parameter group 5-1* <i>Digital Inputs</i>). The corresponding terminal is not active. The quick stop function was activated via serial communication.
Ramping	The motor is accelerating/decelerating using the active ramp up/down. The reference, a limit value, or a standstill is not yet reached.
Ref. high	The sum of all active references is above the reference limit set in 4-55 <i>Warning Reference High</i> .
Ref. low	The sum of all active references is below the reference limit set in 4-54 <i>Warning Reference Low</i> .
Run on ref.	The frequency converter is running in the reference range. The feedback value matches the setpoint value.
Run request	A start command has been given, but the motor is stopped until a run permissive signal is received via digital input.
Running	The frequency converter drives the motor.
Sleep Mode	The energy saving function is enabled. The motor has stopped, but restarts automatically when required.
Speed high	Motor speed is above the value set in 4-53 <i>Warning Speed High</i> .
Speed low	Motor speed is below the value set in 4-52 <i>Warning Speed Low</i> .
Standby	In Auto On mode, the frequency converter starts the motor with a start signal from a digital input or serial communication.
Start delay	In 1-71 <i>Start Delay</i> , a delay starting time was set. A start command is activated and the motor starts after the start delay time expires.
Start fwd/rev	Start forward and start reverse were selected as functions for 2 different digital inputs (parameter group 5-1* <i>Digital Inputs</i>). The motor starts in forward or reverse depending on which corresponding terminal is activated.
Stop	The frequency converter has received a stop command from the LCP, digital input, or serial communication.

Trip	An alarm occurred and the motor is stopped. Once the cause of the alarm is cleared, the frequency converter can be reset manually by pressing [Reset] or remotely by control terminals or serial communication.
Trip lock	An alarm occurred and the motor is stopped. Once the cause of the alarm is cleared, power must be cycled to the frequency converter. The frequency converter can then be reset manually by pressing [Reset] or remotely by control terminals or serial communication.

Table 8.3 Operation Status

NOTICE

In auto/remote mode, the frequency converter requires external commands to execute functions.

9 Warnings and Alarms

9.1 System Monitoring

The frequency converter monitors the condition of its input power, output, and motor factors as well as other system performance indicators. A warning or alarm may not necessarily indicate a problem internal to the frequency converter itself. In many cases, it indicates failure conditions from input voltage, motor load or temperature, external signals, or other areas monitored by the frequency converter's internal logic. Be sure to investigate those areas exterior to the frequency converter as indicated in the alarm or warning.

9.2 Warning and Alarm Types

9.2.1 Warnings

A warning is issued when an alarm condition is impending, or when an abnormal operating condition is present and may result in the frequency converter issuing an alarm. A warning clears itself when the abnormal condition is removed.

9.2.2 Alarm Trip

An alarm is issued when the frequency converter is tripped, that is, the frequency converter suspends operation to prevent frequency converter or system damage. The motor coasts to a stop. The frequency converter logic continues to operate and monitor the frequency converter status. After the fault condition is corrected, the frequency converter can be reset. It is then ready to start operation again.

A trip can be reset in any of 4 ways:

- Pressing [Reset]
- Digital reset input command
- Serial communication reset input command
- Auto reset

9.2.3 Alarm Trip-lock

An alarm that causes the frequency converter to trip-lock requires that input power is cycled. The motor coasts to a stop. The frequency converter logic continues to operate and monitor the frequency converter status. Remove input power to the frequency converter and correct the cause of the fault, then restore power. This action puts the

frequency converter into a trip condition as described above and may be reset in any of those 4 ways.

9.3 Warning and Alarm Displays

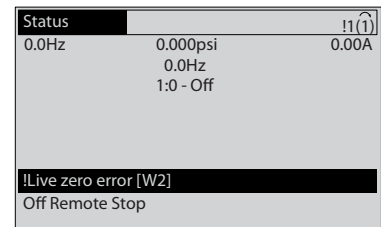

Illustration 9.1 Warning Display Example

An alarm or trip-lock alarm flashes in the display along with the alarm number.

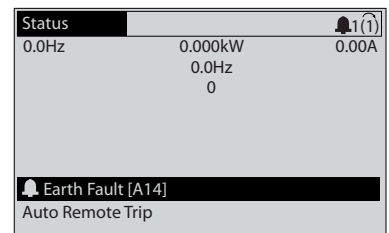
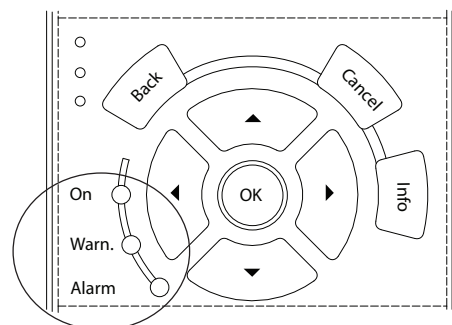

Illustration 9.2 Alarm Display Example

In addition to the text and alarm code on the frequency converter display, there are 3 status indicator lights.



	Warn. LED	Alarm LED
Warning	ON	OFF
Alarm	OFF	ON (Flashing)
Trip-Lock	ON	ON (Flashing)

Illustration 9.3 Indicator Lights

9.4 Warning and Alarm Definitions

Table 9.1 defines whether a warning is issued before an alarm, and whether the alarm trips the unit or trip locks the unit.

No.	Description	Warning	Alarm/Trip	Alarm/Trip lock	Parameter reference
1	10 Volts low	X			
2	Live zero error	(X)	(X)		6-01 Live Zero Timeout Function
4	Mains phase loss	(X)	(X)	(X)	14-12 Function at Mains Imbalance
5	DC link voltage high	X			
6	DC link voltage low	X			
7	DC over voltage	X	X		
8	DC under voltage	X	X		
9	Inverter overloaded	X	X		
10	Motor ETR over temperature	(X)	(X)		1-90 Motor Thermal Protection
11	Motor thermistor over temperature	(X)	(X)		1-90 Motor Thermal Protection
12	Torque limit	X	X		
13	Over Current	X	X	X	
14	Earth (ground) fault	X	X	X	
15	Hardware mismatch		X	X	
16	Short Circuit		X	X	
17	Control word timeout	(X)	(X)		8-04 Control Timeout Function
18	Start Failed				
23	Internal Fan Fault	X			
24	External Fan Fault	X			14-53 Fan Monitor
25	Brake resistor short-circuited	X			
26	Brake resistor power limit	(X)	(X)		2-13 Brake Power Monitoring
27	Brake chopper short-circuited	X	X		
28	Brake check	(X)	(X)		2-15 Brake Check
29	Drive over temperature	X	X	X	
30	Motor phase U missing	(X)	(X)	(X)	4-58 Missing Motor Phase Function
31	Motor phase V missing	(X)	(X)	(X)	4-58 Missing Motor Phase Function
32	Motor phase W missing	(X)	(X)	(X)	4-58 Missing Motor Phase Function
33	Inrush fault		X	X	
34	Fieldbus communication fault	X	X		
35	Out of frequency range	X	X		
36	Mains failure	X	X		
37	Phase Imbalance	X	X		
38	Internal fault		X	X	
39	Heatsink sensor		X	X	
40	Overload of Digital Output Terminal 27	(X)			5-00 Digital I/O Mode, 5-01 Terminal 27 Mode
41	Overload of Digital Output Terminal 29	(X)			5-00 Digital I/O Mode, 5-02 Terminal 29 Mode
42	Overload of Digital Output On X30/6	(X)			5-32 Term X30/6 Digi Out (MCB 101)
42	Overload of Digital Output On X30/7	(X)			5-33 Term X30/7 Digi Out (MCB 101)
46	Pwr. card supply		X	X	
47	24 V supply low	X	X	X	
48	1.8 V supply low		X	X	

No.	Description	Warning	Alarm/Trip	Alarm/Trip lock	Parameter reference
49	Speed limit	X	(X)		1-86 Trip Speed Low [RPM]
50	AMA calibration failed		X		
51	AMA check U _{nom} and I _{nom}		X		
52	AMA low I _{nom}		X		
53	AMA motor too big		X		
54	AMA motor too small		X		
55	AMA Parameter out of range		X		
56	AMA interrupted by user		X		
57	AMA timeout		X		
58	AMA internal fault	X	X		
59	Current limit	X			
60	External Interlock	X			
62	Output Frequency at Maximum Limit	X			
64	Voltage Limit	X			
65	Control board overtemperature	X	X	X	
66	Heat sink Temperature Low	X			
67	Option Configuration has Changed		X		
70	Illegal FC configuration			X	
71	PTC 1 Safe Stop	X	X ¹⁾		
72	Dangerous Failure			X ¹⁾	
73	Safe Stop Auto Restart				
76	Power Unit Setup	X			
77	Reduced Power Mode				
79	Illegal PS config		X	X	
80	Drive Initialized to Default Value		X		
91	Analog input 54 wrong settings			X	
92	NoFlow	X	X		22-2* No-Flow Detection
93	Dry Pump	X	X		22-2* No-Flow Detection
94	End of Curve	X	X		22-5* End of Curve
95	Broken Belt	X	X		22-6* Broken Belt Detection
96	Start Delayed	X			22-7* Short Cycle Protection
97	Stop Delayed	X			22-7* Short Cycle Protection
98	Clock Fault	X			0-7* Clock Settings
104	Mixing Fan Fault	X	X		14-53 Fan Monitor
203	Missing Motor				
204	Locked Rotor				
243	Brake IGBT	X	X		
244	Heatsink temp	X	X	X	
245	Heatsink sensor		X	X	
246	Pwr.card supply		X	X	
247	Pwr.card temp		X	X	
248	Illegal PS config		X	X	
250	New spare parts			X	
251	New Type Code		X	X	

Table 9.1 Alarm/Warning Code List
(X) Dependent on parameter
1) Cannot be Auto reset via 14-20 Reset Mode

9.5 Fault Messages

The following warning/alarm information defines each warning/alarm condition, provides the probable cause for the condition, and details a remedy or troubleshooting procedure.

WARNING 1, 10 Volts low

The control card voltage is below 10 V from terminal 50. Remove some of the load from terminal 50, as the 10 V supply is overloaded. Max. 15 mA or minimum 590 Ω .

This condition can be caused by a short in a connected potentiometer or improper wiring of the potentiometer.

Troubleshooting

- Remove the wiring from terminal 50. If the warning clears, the problem is with the customer wiring. If the warning does not clear, replace the control card.

WARNING/ALARM 2, Live zero error

This warning or alarm only appears if programmed by the user in *6-01 Live Zero Timeout Function*. The signal on one of the analog inputs is less than 50% of the minimum value programmed for that input. Broken wiring or faulty device sending the signal can cause this condition.

Troubleshooting

- Check connections on all the analog input terminals. Control card terminals 53 and 54 for signals, terminal 55 common. MCB 101 terminals 11 and 12 for signals, terminal 10 common. MCB 109 terminals 1, 3, 5 for signals, terminals 2, 4, 6 common).
- Check that the frequency converter programming and switch settings match the analog signal type.
- Perform an input terminal signal test.

WARNING/ALARM 3, No motor

No motor has been connected to the output of the frequency converter.

WARNING/ALARM 4, Mains phase loss

A phase is missing on the supply side, or the mains voltage imbalance is too high. This message also appears for a fault in the input rectifier on the frequency converter. Options are programmed in *14-12 Function at Mains Imbalance*.

Troubleshooting

- Check the supply voltage and supply currents to the frequency converter.

WARNING 5, DC link voltage high

The intermediate circuit voltage (DC) is higher than the high voltage warning limit. The limit is dependent on the frequency converter voltage rating. The unit is still active.

WARNING 6, DC link voltage low

The intermediate circuit voltage (DC) is lower than the low voltage warning limit. The limit is dependent on the frequency converter voltage rating. The unit is still active.

WARNING/ALARM 7, DC overvoltage

If the intermediate circuit voltage exceeds the limit, the frequency converter trips after a time.

Troubleshooting

- Connect a brake resistor.
- Extend the ramp time.
- Change the ramp type.
- Activate the functions in *2-10 Brake Function*.
- Increase the value in *14-26 Trip Delay at Inverter Fault*.

WARNING/ALARM 8, DC under voltage

If the intermediate circuit voltage (DC link) drops below the under voltage limit, the frequency converter checks if a 24 V DC back-up supply is connected. If no 24 V DC back-up supply is connected, the frequency converter trips after a fixed time delay. The time delay varies with unit size.

Troubleshooting

- Check that the supply voltage matches the frequency converter voltage.
- Perform an input voltage test.
- Perform a soft charge circuit test.

WARNING/ALARM 9, Inverter overload

The frequency converter is about to cut out because of an overload (too high current for too long). The counter for electronic, thermal inverter protection gives a warning at 98% and trips at 100%, while giving an alarm. The frequency converter *cannot* be reset until the counter is below 90%.

The fault is that the frequency converter is overloaded by more than 100% for too long.

Troubleshooting

- Compare the output current shown on the LCP with the frequency converter rated current.
- Compare the output current shown on the LCP with measured motor current.
- Display the Thermal Drive Load on the LCP and monitor the value. When running above the frequency converter continuous current rating, the counter should increase. When running below the frequency converter continuous current rating, the counter should decrease.

WARNING/ALARM 10, Motor overload temperature

According to the electronic thermal protection (ETR), the motor is too hot. Select whether the frequency converter gives a warning or an alarm when the counter reaches 100% in *1-90 Motor Thermal Protection*. The fault occurs when the motor is overloaded by more than 100% for too long.

Troubleshooting

- Check for motor overheating.
- Check if the motor is mechanically overloaded.
- Check that the motor current set in *1-24 Motor Current* is correct
- Ensure that motor data in parameters *1-20 to 1-25* are set correctly.
- If an external fan is in use, ensure that is selected in *1-91 Motor External Fan*.
- Running AMA in *1-29 Automatic Motor Adaptation (AMA)* tunes the frequency converter to the motor more accurately and reduces thermal loading.

WARNING/ALARM 11, Motor thermistor overtemp

The thermistor might be disconnected. Select whether the frequency converter gives a warning or an alarm in *1-90 Motor Thermal Protection*.

Troubleshooting

- Check for motor overheating
- Check if the motor is mechanically overloaded
- Check that the thermistor is connected correctly between either terminal 53 or 54 (analog voltage input) and terminal 50 (+10 V supply) and that the terminal switch for 53 or 54 is set for voltage. Check *1-93 Thermistor Source* selects terminal 53 or 54.
- When using digital inputs 18 or 19, check that the thermistor is connected correctly between either terminal 18 or 19 (digital input PNP only) and terminal 50
- If a KTY sensor is used, check for correct connection between terminals 54 and 55
- If using a thermal switch or thermistor, check that the programming in *1-93 Thermistor Source* matches sensor wiring

WARNING/ALARM 12, Torque limit

The torque has exceeded the value in *4-16 Torque Limit Motor Mode* or the value in *4-17 Torque Limit Generator Mode*. *14-25 Trip Delay at Torque Limit* can change this from a warning only condition to a warning followed by an alarm.

Troubleshooting

- If the motor torque limit is exceeded during ramp up, extend the ramp up time.
- If the generator torque limit is exceeded during ramp down, extend the ramp down time.
- If torque limit occurs while running, possibly increase the torque limit. Be sure the system can operate safely at a higher torque.
- Check the application for excessive current draw on the motor.

WARNING/ALARM 13, Over current

The inverter peak current limit (approximately 200% of the rated current) is exceeded. The warning lasts about 1.5 s, then the frequency converter trips and issues an alarm. This fault may be caused by shock loading or fast acceleration with high inertia loads. If extended mechanical brake control is selected, trip can be reset externally.

Troubleshooting

- Remove power and check if the motor shaft can be turned.
- Check that the motor size matches the frequency converter.
- Check parameters *1-20 to 1-25* for correct motor data.

ALARM 14, Earth (ground) fault

There is current from the output phases to ground, either in the cable between the frequency converter and the motor or in the motor itself.

Troubleshooting

- Remove power to the frequency converter and repair the ground fault.
- Check for ground faults in the motor by measuring the resistance to ground of the motor leads and the motor with a megohmmeter.
- Perform current sensor test.

ALARM 15, Hardware mismatch

A fitted option is not operational with the present control board hardware or software.

Record the value of the following parameters and contact the Danfoss supplier:

- *15-40 FC Type*
- *15-41 Power Section*
- *15-42 Voltage*
- *15-43 Software Version*
- *15-45 Actual Typecode String*
- *15-49 SW ID Control Card*
- *15-50 SW ID Power Card*
- *15-60 Option Mounted*
- *15-61 Option SW Version* (for each option slot)

ALARM 16, Short circuit

There is short-circuiting in the motor or motor wiring.

- Remove power to the frequency converter and repair the short circuit.

WARNING/ALARM 17, Control word timeout

There is no communication to the frequency converter. The warning is only active when *8-04 Control Timeout Function* is NOT set to OFF.

If *8-04 Control Timeout Function* is set to [5] *Stop and trip*, a warning appears and the frequency converter ramps down until it trips then displays an alarm.

Troubleshooting

- Check connections on the serial communication cable.
- Increase the value in *8-03 Control Timeout Time*.
- Check the operation of the communication equipment.
- Verify a proper installation based on EMC requirements.

WARNING/ALARM 22, Hoist mechanical brake

Report value shows what kind it is.

0=The torque ref. was not reached before timeout.

1=There was no brake feedback before timeout.

WARNING 23, Internal fan fault

The fan warning function is an extra protective function that checks if the fan is running/mounted. The fan warning can be disabled in *14-53 Fan Monitor ([0] Disabled)*.

Troubleshooting

- Check fan resistance.
- Check soft charge fuses.

WARNING 24, External fan fault

The fan warning function is an extra protective function that checks if the fan is running/mounted. The fan warning can be disabled in *14-53 Fan Monitor ([0] Disabled)*.

Troubleshooting

- Check fan resistance.
- Check soft charge fuses.

WARNING 25, Brake resistor short circuit

The brake resistor is monitored during operation. If a short circuit occurs, the brake function is disabled and the warning appears. The frequency converter is still operational but without the brake function. Remove power to the frequency converter and replace the brake resistor (see *2-15 Brake Check*).

WARNING/ALARM 26, Brake resistor power limit

The power transmitted to the brake resistor is calculated as a mean value over the last 120 s of run time. The calculation is based on the intermediate circuit voltage and the brake resistance value set in *2-16 AC brake Max. Current*. The warning is active when the dissipated braking is higher than 90% of the brake resistance power. If *[2] Trip* is selected in *2-13 Brake Power Monitoring*, the frequency converter will trip when the dissipated braking power reaches 100%.



There is a risk of substantial power being transmitted to the brake resistor if the brake transistor is short-circuited.

WARNING/ALARM 27, Brake chopper fault

The brake transistor is monitored during operation and if a short circuit occurs, the brake function is disabled and a warning is issued. The frequency converter is still

operational but, since the brake transistor has short-circuited, substantial power is transmitted to the brake resistor, even if it is inactive.

Remove power to the frequency converter and remove the brake resistor.

This alarm/warning could also occur should the brake resistor overheat. Terminals 104 and 106 are available as brake resistors Klixon inputs.

WARNING/ALARM 28, Brake check failed

The brake resistor is not connected or not working. Check *2-15 Brake Check*.

ALARM 29, Heat Sink temp

The maximum temperature of the heat sink has been exceeded. The temperature fault does not reset until the temperature drops below a defined heat sink temperature. The trip and reset points are different based on the frequency converter power size.

Troubleshooting

Check for the following conditions

- Ambient temperature too high
- Motor cable too long
- Incorrect airflow clearance above and below the frequency converter
- Blocked airflow around the frequency converter
- Damaged heat sink fan
- Dirty heat sink

This alarm is based on the temperature measured by the heat sink sensor mounted inside the IGBT modules.

Troubleshooting

- Check fan resistance.
- Check soft charge fuses.
- Check IGBT thermal sensor.

ALARM 30, Motor phase U missing

Motor phase U between the frequency converter and the motor is missing.

Troubleshooting

- Remove power from the frequency converter and check motor phase U.

ALARM 31, Motor phase V missing

Motor phase V between the frequency converter and the motor is missing.

Troubleshooting

- Remove power from the frequency converter and check motor phase V.

ALARM 32, Motor phase W missing

Motor phase W between the frequency converter and the motor is missing.

Troubleshooting

- Remove power from the frequency converter and check motor phase W.

ALARM 33, Inrush fault

Too many power-ups have occurred within a short time period.

Troubleshooting

- Let the unit cool to operating temperature.

WARNING/ALARM 34, Fieldbus communication fault

The fieldbus on the communication option card is not working.

WARNING/ALARM 36, Mains failure

This warning/alarm is only active if the supply voltage to the frequency converter is lost and *14-10 Mains Failure* is NOT set to [0] *No Function*.

Troubleshooting

- Check the fuses to the frequency converter and mains power supply to the unit.

ALARM 38, Internal fault

When an internal fault occurs, a code number defined in the table below is displayed.

Troubleshooting

- Cycle power
- Check that the option is properly installed
- Check for loose or missing wiring

It may be necessary to contact the Danfoss supplier or service department. Note the code number for further troubleshooting directions.

No.	Text
0	Serial port cannot be initialised. Contact the Danfoss supplier or Danfoss Service Department.
256-258	Power EEPROM data is defective or too old.
512	Control board EEPROM data is defective or too old.
513	Communication time out reading EEPROM data
514	Communication time out reading EEPROM data
515	Application oriented control cannot recognize the EEPROM data.
516	Cannot write to the EEPROM because a write command is on progress.
517	Write command is under time out
518	Failure in the EEPROM
519	Missing or invalid barcode data in EEPROM
783	Parameter value outside of min/max limits
1024-1279	A centelegram that has to be sent can not be sent.
1281	Digital signal processor flash timeout
1282	Power micro software version mismatch
1283	Power EEPROM data version mismatch
1284	Cannot read digital signal processor software version
1299	Option SW in slot A is too old
1300	Option SW in slot B is too old
1301	Option SW in slot C0 is too old

No.	Text
1302	Option SW in slot C1 is too old
1315	Option SW in slot A is not supported (not allowed)
1316	Option SW in slot B is not supported (not allowed)
1317	Option SW in slot C0 is not supported (not allowed)
1318	Option SW in slot C1 is not supported (not allowed)
1379	Option A did not respond when calculating platform version
1380	Option B did not respond when calculating platform version
1381	Option C0 did not respond when calculating platform version.
1382	Option C1 did not respond when calculating platform version.
1536	An exception in the application oriented control is registered. Debug information written in LCP
1792	DSP watchdog is active. Debugging of power part data, motor oriented control data not transferred correctly.
2049	Power data restarted
2064-2072	H081x: option in slot x has restarted
2080-2088	H082x: option in slot x has issued a powerup-wait
2096-2104	H983x: option in slot x has issued a legal powerup-wait
2304	Could not read any data from power EEPROM
2305	Missing SW version from power unit
2314	Missing power unit data from power unit
2315	Missing SW version from power unit
2316	Missint lo_statepage from power unit
2324	Power card configuration is determined to be incorrect at power up
2325	A power card has stopped communicating while main power is applied
2326	Power card configuration is determined to be incorrect after the delay for power cards to register.
2327	Too many power card locations have been registered as present.
2330	Power size information between the power cards does not match.
2561	No communication from DSP to ATACD
2562	No communication from ATACD to DSP (state running)
2816	Stack overflow control board module
2817	Scheduler slow tasks
2818	Fast tasks
2819	Parameter thread
2820	LCP stack overflow
2821	Serial port overflow
2822	USB port overflow
2836	cfListMempool too small
3072-5122	Parameter value is outside its limits

No.	Text
5123	Option in slot A: Hardware incompatible with control board hardware
5124	Option in slot B: Hardware incompatible with Control board hardware.
5125	Option in slot C0: Hardware incompatible with control board hardware.
5126	Option in slot C1: Hardware incompatible with control board hardware.
5376-6231	Out of memory

Table 9.2

ALARM 39, Heat sink sensor

No feedback from the heat sink temperature sensor.

The signal from the IGBT thermal sensor is not available on the power card. The problem could be on the power card, on the gate drive card, or the ribbon cable between the power card and gate drive card.

WARNING 40, Overload of digital output terminal 27

Check the load connected to terminal 27 or remove short-circuit connection. Check 5-00 *Digital I/O Mode* and 5-01 *Terminal 27 Mode*.

WARNING 41, Overload of digital output terminal 29

Check the load connected to terminal 29 or remove short-circuit connection. Check 5-00 *Digital I/O Mode* and 5-02 *Terminal 29 Mode*.

WARNING 42, Overload of digital output on X30/6 or overload of digital output on X30/7

For X30/6, check the load connected to X30/6 or remove the short-circuit connection. Check 5-32 *Term X30/6 Digi Out (MCB 101)*.

For X30/7, check the load connected to X30/7 or remove the short-circuit connection. Check 5-33 *Term X30/7 Digi Out (MCB 101)*.

ALARM 46, Power card supply

The supply on the power card is out of range.

There are 3 power supplies generated by the switch mode power supply (SMPS) on the power card: 24 V, 5 V, and ±18 V. When powered with 24 V DC with the MCB 107 option, only the 24 V and 5 V supplies are monitored. When powered with 3-phase mains voltage, all 3 supplies are monitored.

WARNING 47, 24 V supply low

The 24 V DC is measured on the control card. The external 24 V DC back-up power supply may be overloaded, otherwise contact Danfoss.

WARNING 48, 1.8 V supply low

The 1.8 V DC supply used on the control card is outside of allowable limits. The power supply is measured on the control card. Check for a defective control card. If an option card is present, check for an overvoltage condition.

WARNING 49, Speed limit

When the speed is not within the specified range in 4-11 *Motor Speed Low Limit [RPM]* and 4-13 *Motor Speed High Limit [RPM]*, the frequency converter shows a warning. When the speed is below the specified limit in 1-86 *Trip Speed Low [RPM]* (except when starting or stopping) the frequency converter trips.

ALARM 50, AMA calibration failed

Contact the Danfoss supplier or Danfoss Service Department.

ALARM 51, AMA check U_{nom} and I_{nom}

The settings for motor voltage, motor current, and motor power are wrong. Check the settings in parameters 1-20 to 1-25.

ALARM 52, AMA low I_{nom}

The motor current is too low. Check the settings.

ALARM 53, AMA motor too big

The motor is too big for the AMA to operate.

ALARM 54, AMA motor too small

The motor is too small for the AMA to operate.

ALARM 55, AMA Parameter out of range

The parameter values of the motor are outside of the acceptable range. AMA does not run.

ALARM 56, AMA interrupted by user

The user has interrupted the AMA.

ALARM 57, AMA internal fault

Try to restart AMA again a number of times, until the AMA is carried out. Note that repeated runs may heat the motor to a level where the resistance R_s and R_r are increased. In most cases, however, this is not critical.

ALARM 58, AMA internal fault

Contact Danfoss.

WARNING 59, Current limit

The current is higher than the value in 4-18 *Current Limit*.

Troubleshooting

- Ensure that motor data in parameters 1-20 to 1-25 are set correctly.
- Possibly increase the current limit. Be sure that the system can operate safely at a higher limit.

WARNING 60, External interlock

External interlock has been activated. To resume normal operation, apply 24 V DC to the terminal programmed for external interlock and reset the frequency converter (via serial communication, digital I/O, or by pressing [Reset]).

WARNING/ALARM 61, Tracking error

An error between calculated motor speed and speed measurement from feedback device. The function Warning/Alarm/Disable is set in 4-30 *Motor Feedback Loss Function*. Accepted error setting in 4-31 *Motor Feedback Speed Error* and the allowed time the error occur setting in 4-32 *Motor Feedback Loss Timeout*. During a commissioning procedure the function may be effective.

WARNING 62, Output frequency at maximum limit

The output frequency is higher than the value set in 4-19 *Max Output Frequency*.

ALARM 64, Voltage Limit

The load and speed combination demands a motor voltage higher than the actual DC-link voltage.

WARNING/ALARM 65, Control card over temperature

The control card has reached its trip temperature of 75 °C.

WARNING 66, Heat sink temperature low

The frequency converter is too cold to operate. This warning is based on the temperature sensor in the IGBT module.

Increase the ambient temperature of the unit. Also, a trickle amount of current can be supplied to the frequency converter whenever the motor is stopped by setting 2-00 *DC Hold/Preheat Current* at 5% and 1-80 *Function at Stop*.

Troubleshooting

- Check the temperature sensor.
- Check the sensor wire between the IGBT and the gate drive card.

ALARM 67, Option module configuration has changed

One or more options have either been added or removed since the last power-down. Check that the configuration change is intentional and reset the unit.

ALARM 68, Safe Stop activated

Safe Torque Off has been activated.

Troubleshooting

- To resume normal operation, apply 24 V DC to terminal 37, then send a reset signal (via bus, digital I/O, or by pressing [Reset]).

ALARM 69, Power card temperature

The temperature sensor on the power card is either too hot or too cold.

Troubleshooting

- Check the operation of the door fans.
- Check that the filters for the door fans are not blocked.
- Check that the gland plate is properly installed on IP21/IP54 (NEMA 1/12) frequency converters.

ALARM 70, Illegal FC configuration

The control card and power card are incompatible.

Troubleshooting

- Contact the supplier with the type code of the unit from the nameplate and the part numbers of the cards to check compatibility.

ALARM 71, PTC 1 safe stop

Safe Stop has been activated from the MCB 112 PTC Thermistor Card (motor too warm). Normal operation can be resumed when the MCB 112 applies 24 V DC to T37 again (when the motor temperature reaches an acceptable level) and when the Digital Input from the MCB 112 is

deactivated. When that happens, a reset signal must be sent (via Bus, Digital I/O, or by pressing [Reset]).

NOTICE

If automatic restart is enabled, the motor may start when the fault is cleared.

ALARM 72, Dangerous failure

Safe stop with trip lock. Unexpected signal levels on safe stop and digital input from the MCB 112 PTC thermistor card.

WARNING 73, Safe Stop auto restart

Safe stopped. With automatic restart enabled, the motor may start when the fault is cleared.

WARNING 76, Power unit setup

The required number of power units does not match the detected number of active power units. When replacing an F-frame module, this occurs if the power specific data in the module power card does not match the rest of the frequency converter.

Troubleshooting

- Confirm the spare part and its power card are the correct part number.

WARNING 77, Reduced power mode

This warning indicates that the frequency converter is operating in reduced power mode (i.e. less than the allowed number of inverter sections). This warning is generated on power cycle when the frequency converter is set to run with fewer inverters and remains on.

ALARM 79, Illegal power section configuration

The scaling card is the incorrect part number or not installed. Also, the MK102 connector on the power card could not be installed.

ALARM 80, Drive initialised to default value

Parameter settings are initialised to default settings after a manual reset.

Troubleshooting

- Reset the unit to clear the alarm.

ALARM 81, CSIV corrupt

CSIV (Customer Specific Initialisation Values) file has syntax errors.

ALARM 82, CSIV parameter error

CSIV (Customer Specific Initialisation Values) failed to initialise a parameter.

ALARM 85, Dang fail PB

PROFIBUS/PROFIsafe error.

WARNING/ALARM 104, Mixing fan fault

The fan monitor checks that the fan is spinning at frequency converter power-up or whenever the mixing fan is turned on. If the fan is not operating, the fault is issued. The mixing-fan fault can be configured as a warning or an alarm trip by 14-53 *Fan Monitor*.

Troubleshooting

- Cycle power to the frequency converter to determine if the warning/alarm returns.

WARNING 250, New spare part

A component in the frequency converter has been replaced. Reset the frequency converter to resume normal operation.

WARNING 251, New typecode

The power card or other components have been replaced and the typecode changed.

Troubleshooting

- Reset to remove the warning and resume normal operation.

10 Basic Troubleshooting

10.1 Start Up and Operation

Symptom	Possible cause	Test	Solution
Display dark/No function	Missing input power	See <i>Table 4.1</i>	Check the input power source
	Missing or open fuses or circuit breaker tripped	See <i>Open fuses and Tripped circuit breaker</i> in this table for possible causes	Follow the recommendations provided
	No power to the LCP	Check the LCP cable for proper connection or damage	Replace the faulty LCP or connection cable
	Shortcut on control voltage (terminal 12 or 50) or at control terminals	Check the 24 V control voltage supply for terminals 12/13 to 20-39 or 10 V supply for terminals 50 to 55	Wire the terminals properly
	Wrong LCP (LCP from VLT® 2800 or 5000/6000/8000/ FCD or FCM)		Use only LCP 101 (P/N 130B1124) or LCP 102 (P/N 130B1107)
	Wrong contrast setting		Press [Status] + [▲]/[▼] to adjust the contrast
	Display (LCP) is defective	Test using a different LCP	Replace the faulty LCP or connection cable
	Internal voltage supply fault or SMPS is defective		Contact supplier
Intermittent display	Overloaded power supply (SMPS) due to improper control wiring or a fault within the frequency converter	To rule out a problem in the control wiring, disconnect all control wiring by removing the terminal blocks.	If the display stays lit, then the problem is in the control wiring. Check the wiring for shorts or incorrect connections. If the display continues to cut out, follow the procedure for display dark.
Motor not running	Service switch open or missing motor connection	Check if the motor is connected and the connection is not interrupted (by a service switch or other device).	Connect the motor and check the service switch
	No mains power with 24 V DC option card	If the display is functioning but no output, check that mains power is applied to the frequency converter.	Apply mains power to run the unit
	LCP Stop	Check if [Off] has been pressed	Press [Auto On] or [Hand On] (depending on operation mode) to run the motor
	Missing start signal (Standby)	Check <i>5-10 Terminal 18 Digital Input</i> for correct setting for terminal 18 (use default setting)	Apply a valid start signal to start the motor
	Motor coast signal active (Coasting)	Check <i>5-12 Coast inv.</i> for correct setting for terminal 27 (use default setting).	Apply 24 V on terminal 27 or program this terminal to <i>no operation</i>
	Wrong reference signal source	Check reference signal: Local, remote or bus reference? Preset reference active? Terminal connection correct? Scaling of terminals correct? Reference signal available?	Program correct settings. Check <i>3-13 Reference Site</i> . Set preset reference active in parameter group <i>3-1* References</i> . Check for correct wiring. Check scaling of terminals. Check reference signal.

Symptom	Possible cause	Test	Solution
Motor running in wrong direction	Motor rotation limit	Check that 4-10 <i>Motor Speed Direction</i> is programmed correctly.	Program correct settings
	Active reversing signal	Check if a reversing command is programmed for the terminal in parameter group 5-1* <i>Digital inputs</i> .	Deactivate reversing signal
	Wrong motor phase connection		See chapter 3.4.5 <i>Motor Rotation Check</i> in this manual
Motor is not reaching maximum speed	Frequency limits set wrong	Check output limits in 4-13 <i>Motor Speed High Limit [RPM]</i> , 4-14 <i>Motor Speed High Limit [Hz]</i> and 4-19 <i>Max Output Frequency</i> .	Program correct limits
	Reference input signal not scaled correctly	Check reference input signal scaling in 6-0* <i>Analog I/O Mode</i> and parameter group 3-1* <i>References</i> . Reference limits in parameter group 3-0* <i>Reference Limit</i> .	Program correct settings
Motor speed unstable	Possible incorrect parameter settings	Check the settings of all motor parameters, including all motor compensation settings. For closed loop operation, check PID settings.	Check settings in parameter group 1-6* <i>Load Depen. Setting</i> . For closed loop operation, check settings in parameter group 20-0* <i>Feedback</i> .
Motor runs rough	Possible overmagnetisation	Check for incorrect motor settings in all motor parameters	Check motor settings in parameter groups 1-2* <i>Motor Data</i> , 1-3* <i>Adv Motor Data</i> , and 1-5* <i>Load Indep. Setting</i> .
Motor will not brake	Possible incorrect settings in the brake parameters. Possible too short ramp down times	Check brake parameters. Check ramp time settings	Check parameter group 2-0* <i>DC Brake</i> and 3-0* <i>Reference Limits</i> .
Open power fuses or circuit breaker trip	Phase-to-phase short	Motor or panel has a short phase to phase. Check motor and panel phase for shorts	Eliminate any shorts detected
	Motor overload	Motor is overloaded for the application	Perform startup test and verify motor current is within specifications. If motor current is exceeding nameplate full load current, motor may run only with reduced load. Review the specifications for the application.
	Loose connections	Perform pre-startup check for loose connections	Tighten loose connections
Mains current imbalance greater than 3%	Problem with mains power (See <i>Alarm 4 Mains phase loss</i> description)	Rotate input power leads into the frequency converter one position: A to B, B to C, C to A.	If imbalanced leg follows the wire, it is a power problem. Check mains power supply.
	Problem with the frequency converter	Rotate input power leads into the frequency converter one position: A to B, B to C, C to A.	If imbalance leg stays on same input terminal, it is a problem with the unit. Contact the supplier.
Motor current imbalance greater than 3%	Problem with motor or motor wiring	Rotate output motor leads one position: U to V, V to W, W to U.	If imbalanced leg follows the wire, the problem is in the motor or motor wiring. Check motor and motor wiring.
	Problem with the frequency converters	Rotate output motor leads one position: U to V, V to W, W to U.	If imbalance leg stays on same output terminal, it is a problem with the unit. Contact the supplier.

Symptom	Possible cause	Test	Solution
Acoustic noise or vibration (e.g. a fan blade is making noise or vibrations at certain frequencies)	Resonances, e.g. in the motor/fan system	Bypass critical frequencies by using parameters in parameter group 4-6* <i>Speed Bypass</i>	Check if noise and/or vibration have been reduced to an acceptable limit
		Turn off over-modulation in 14-03 <i>Overmodulation</i>	
		Change switching pattern and frequency in parameter group 14-0* <i>Inverter Switching</i>	
		Increase Resonance Dampening in 1-64 <i>Resonance Damping</i>	

Table 10.1 Troubleshooting

11 Specifications

11.1 Power-dependent Specifications

	N110	N132	N160	N200	N250	N315
Normal Load*	NO	NO	NO	NO	NO	NO
Typical Shaft output at 400 V [kW]	110	132	160	200	250	315
Typical Shaft output at 460 V [hp]	150	200	250	300	350	450
Typical Shaft output at 480 V [kW]	132	160	200	250	315	355
Enclosure IP21	D1h	D1h	D1h	D2h	D2h	D2h
Enclosure IP54	D1h	D1h	D1h	D2h	D2h	D2h
Enclosure IP20	D3h	D3h	D3h	D4h	D4h	D4h
Output current						
Continuous (at 400 V) [A]	212	260	315	395	480	588
Intermittent (60 s overload) (at 400 V)[A]	233	286	347	435	528	647
Continuous (at 460/500 V) [A]	190	240	302	361	443	535
Intermittent (60 s overload) (at 460/500 V) [kVA]	209	264	332	397	487	588
Continuous kVA (at 400 V) [kVA]	147	180	218	274	333	407
Continuous kVA (at 460 V) [kVA]	151	191	241	288	353	426
Max. Input current						
Continuous (at 400 V) [A]	204	251	304	381	463	567
Continuous (at 460/500 V) [A]	183	231	291	348	427	516
Max. cable size: mains, motor, brake and load share mm (AWG)	2 x95 (2x3/0)			2x185 (2x350)		
Max. external mains fuses [A]	315	350	400	550	630	800
Estimated power loss at 400 V [W]	2555	2949	3764	4109	5129	6663
Estimated power loss at 460 V [W]	2257	2719	3622	3561	4558	5703
Weight, enclosure IP21, IP54 kg (lbs.)	62 (135)			125 (275)		
Weight, enclosure IP20 kg (lbs.)	62 (135)			125 (275)		
Efficiency	0.98					
Output frequency	0-590 Hz					
*Normal overload=110% current for 60 s						

Table 11.1 Mains Supply 3x380-480 V AC

	N75K	N90K	N110	N132	N160	N200
Normal Load*	NO	NO	NO	NO	NO	NO
Typical Shaft output at 550 V [kW]	55	75	90	110	132	160
Typical Shaft output at 575 V [hp]	75	100	125	150	200	250
Typical Shaft output at 690 V [kW]	75	90	110	132	160	200
Enclosure IP21	D1h	D1h	D1h	D1h	D1h	D2h
Enclosure IP54	D1h	D1h	D1h	D1h	D1h	D2h
Enclosure IP20	D3h	D3h	D3h	D3h	D3h	D4h
Output current						
Continuous (at 550 V) [A]	90	113	137	162	201	253
Intermittent (60 s overload) (at 550 V)[A]	99	124	151	178	221	278
Continuous (at 575/690 V) [A]	86	108	131	155	192	242
Intermittent (60 s overload) (at 575/690 V) [kVA]	95	119	144	171	211	266
Continuous kVA (at 550 V) [kVA]	86	108	131	154	191	241
Continuous kVA (at 575 V) [kVA]	86	108	130	154	191	241
Continuous kVA (at 690 V) [kVA]	103	129	157	185	229	289
Max. Input current						
Continuous (at 550 V) [A]	89	110	130	158	198	245
Continuous (at 575 V) [A]	85	106	124	151	189	234
Continuous (at 690 V) [A]	87	109	128	155	197	240
Max. cable size: mains, motor, brake and load share [mm (AWG)]	2x95 (2x3/0)					2x185 (2x350 mcm)
Max. external mains fuses [A]	160	315	315	315	350	350
Estimated power loss at 575 V [W]	1161	1426	1739	2099	2646	3071
Estimated power loss at 690 V [W]	1203	1476	1796	2165	2738	3172
Weight, enclosure IP21, IP54 kg (lbs.)	62 (135)					125 (275)
Weight, enclosure IP20 kg (lbs.)	62 (135)					125 (275)
Efficiency	0.98					
Output frequency	0-590 Hz					
Heatsink overtemp. trip	110 °C					
Power card ambient trip	75 °C					
*Normal overload=110% current for 60 s						

Table 11.2 Mains Supply 3x525-690 V AC

	N250	N315	N400
Normal Load*	NO	NO	NO
Typical Shaft output at 550 V [kW]	200	250	315
Typical Shaft output at 575 V [hp]	300	350	400
Typical Shaft output at 690 V [kW]	250	315	400
Enclosure IP21	D2h	D2h	D2h
Enclosure IP54	D2h	D2h	D2h
Enclosure IP20	D4h	D4h	D4h
Output current			
Continuous (at 550 V) [A]	303	360	418
Intermittent (60 s overload) (at 550 V)[A]	333	396	460
Continuous (at 575/690 V) [A]	290	344	400
Intermittent (60 s overload) (at 575/690 V) [kVA]	319	378	440
Continuous kVA (at 550 V) [kVA]	289	343	398
Continuous kVA (at 575 V) [kVA]	289	343	398
Continuous kVA (at 690 V) [kVA]	347	411	478
Max. Input current			
Continuous (at 550 V) [A]	299	355	408
Continuous (at 575 V) [A]	286	339	390
Continuous (at 690 V) [A]	296	352	400
Max. cable size: mains, motor, brake and load share, mm (AWG)	2x185 (2x350 mcm)		
Max. external mains fuses [A]	400	500	550
Estimated power loss at 575 V [W]	3719	4460	5023
Estimated power loss at 690 V [W]	3848	4610	5150
Weight, enclosure IP21, IP54 kg (lbs.)	125 (275)		
Weight, enclosure IP20 kg (lbs.)	125 (275)		
Efficiency	0.98		
Output frequency	0-590 Hz		
Heatsink overtemp. trip	110 °C		
Power card ambient trip	75 °C		
*Normal overload=110% current for 60 s			

Table 11.3 Mains Supply 3x525-690 V AC

The typical power loss is at nominal load conditions and expected to be within $\pm 15\%$ (tolerance relates to variety in voltage and cable conditions).

The losses are based on the default switching frequency. The losses increase significantly at higher switching frequencies.

The options cabinet adds weight to the frequency converter. The maximum weights of the D5h–D8h frames is shown in *Table 11.4*

Frame size	Description	Maximum weight [kg] ([lbs.])
D5h	D1h ratings+disconnect and/or brake chopper	166 (255)
D6h	D1h ratings+contactor and/or circuit breaker	129 (285)
D7h	D2h ratings+disconnect and/or brake chopper	200 (440)
D8h	D2h ratings+contactor and/or circuit breaker	225 (496)

Table 11.4 D5h–D8h Weights

11.2 General Technical Data

Mains supply (L1, L2, L3)

Supply voltage	380–480 V \pm 10%, 525–690 V \pm 10%
----------------	--

Mains voltage low/mains voltage drop-out:

During low mains voltage or a mains drop-out, the frequency converter continues until the intermediate circuit voltage drops below the minimum stop level, which corresponds typically to 15% below the frequency converter's lowest rated supply voltage. Power-up and full torque cannot be expected at mains voltage lower than 10% below the frequency converter's lowest rated supply voltage.

Supply frequency	50/60 Hz \pm 5%
Max. imbalance temporary between mains phases	3.0% of rated supply voltage
True power factor (λ)	\geq 0.9 nominal at rated load
Displacement power factor (cos Φ) near unity	(>0.98)
Switching on input supply L1, L2, L3 (power ups)	maximum one time/2 min
Environment according to EN60664-1	overvoltage category III/pollution degree 2

The unit is suitable for use on a circuit capable of delivering not more than 100000 RMS symmetrical Amperes, 480/600 V

Motor output (U, V, W)

Output voltage	0-100% of supply voltage
Output frequency	0-590 Hz ¹⁾
Switching on output	Unlimited
Ramp times	0.01-3600 s

1) From software version 1.10 the output frequency of the frequency converter is limited to 590 Hz. Contact local Danfoss partner for further information.

Torque characteristics

Starting torque (Constant torque)	maximum 110% for 60 s ¹⁾
Starting torque	maximum 135% up to 0.5 s ¹⁾
Overload torque (Constant torque)	maximum 110% for 60 s ¹⁾

1) Percentage relates to the frequency converter's nominal torque

Cable lengths and cross-sections

Max. motor cable length, screened/armoured	150 m
Max. motor cable length, unscreened/unarmoured	300 m
Max. cross section to motor, mains, load sharing and brake ¹⁾	
Maximum cross section to control terminals, rigid wire	1.5 mm ² /16 AWG (2x0.75 mm ²)
Maximum cross section to control terminals, flexible cable	1 mm ² /18 AWG
Maximum cross section to control terminals, cable with enclosed core	0.5 mm ² /20 AWG
Minimum cross section to control terminals	0.25 mm ²

1) Depending on voltage and power.

Digital inputs

Programmable digital inputs	4 (6)
Terminal number	18, 19, 27 ¹⁾ , 29 ¹⁾ , 32, 33
Logic	PNP or NPN
Voltage level	0-24 V DC
Voltage level, logic '0' PNP	<5 V DC
Voltage level, logic '1' PNP	>10 V DC
Voltage level, logic '0' NPN	>19 V DC
Voltage level, logic '1' NPN	<14V DC
Maximum voltage on input	28 V DC
Input resistance, R _i	approx. 4 k Ω

All digital inputs are galvanically isolated from the supply voltage (PELV) and other high-voltage terminals.

1) Terminals 27 and 29 can also be programmed as output.

Analog inputs

Number of analog inputs	2
Terminal number	53, 54
Modes	Voltage or current
Mode select	Switches A53 and A54
Voltage mode	Switch A53/A54=(U)
Voltage level	0 V to 10 V (scaleable)
Input resistance, R_i	approx. 10 k Ω
Max. voltage	± 20 V
Current mode	Switch A53/A54=(I)
Current level	0/4 to 20 mA (scaleable)
Input resistance, R_i	approx. 200 Ω
Max. current	30 mA
Resolution for analog inputs	10 bit (+sign)
Accuracy of analog inputs	Max. error 0.5% of full scale
Bandwidth	100 Hz

The analog inputs are galvanically isolated from the supply voltage (PELV) and other high-voltage terminals.

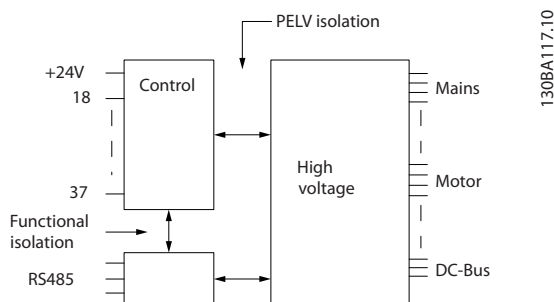

Illustration 11.1 PELV Isolation

Pulse inputs

Programmable pulse inputs	2
Terminal number pulse	29, 33
Max. frequency at terminal, 29, 33	110 kHz (Push-pull driven)
Max. frequency at terminal, 29, 33	5 kHz (open collector)
Min. frequency at terminal 29, 33	4 Hz
Voltage level	see chapter 11.2.1 Digital Inputs
Maximum voltage on input	28 V DC
Input resistance, R_i	approx. 4 k Ω
Pulse input accuracy (0.1-1 kHz)	Max. error: 0.1% of full scale

Analog output

Number of programmable analog outputs	1
Terminal number	42
Current range at analog output	0/4-20 mA
Max. resistor load to common at analog output	500 Ω
Accuracy on analog output	Max. error: 0.8% of full scale
Resolution on analog output	8 bit

The analog output is galvanically isolated from the supply voltage (PELV) and other high-voltage terminals.

Control card, RS-485 serial communication

Terminal number	68 (P,TX+, RX+), 69 (N,TX-, RX-)
Terminal number 61	Common for terminals 68 and 69

The RS-485 serial communication circuit is functionally seated from other central circuits and galvanically isolated from the supply voltage (PELV).

Digital output

Programmable digital/pulse outputs	2
Terminal number	27, 29 ¹⁾
Voltage level at digital/frequency output	0-24 V
Max. output current (sink or source)	40 mA
Max. load at frequency output	1 k Ω
Max. capacitive load at frequency output	10 nF
Minimum output frequency at frequency output	0 Hz
Maximum output frequency at frequency output	32 kHz
Accuracy of frequency output	Max. error: 0.1% of full scale
Resolution of frequency outputs	12 bit

1) Terminal 27 and 29 can also be programmed as input.

The digital output is galvanically isolated from the supply voltage (PELV) and other high-voltage terminals.

Control card, 24 V DC output

Terminal number	12, 13
Max. load	200 mA

The 24 V DC supply is galvanically isolated from the supply voltage (PELV), but has the same potential as the analog and digital inputs and outputs.

Relay outputs

Programmable relay outputs	2
Relay 01 Terminal number	1-3 (break), 1-2 (make)
Max. terminal load (AC-1) ¹⁾ on 1-2 (NO) (Resistive load) ^{2),3)}	400 V AC, 2 A
Max. terminal load (AC-15) ¹⁾ on 1-2 (NO) (Inductive load @ cos ϕ 0.4)	240 V AC, 0.2 A
Max. terminal load (DC-1) ¹⁾ on 1-2 (NO) (Resistive load)	80 V DC, 2 A
Max. terminal load (DC-13) ¹⁾ on 1-2 (NO) (Inductive load)	24 V DC, 0.1 A
Max. terminal load (AC-1) ¹⁾ on 1-3 (NC) (Resistive load)	240 V AC, 2 A
Max. terminal load (AC-15) ¹⁾ on 1-3 (NC) (Inductive load @ cos ϕ 0.4)	240 V AC, 0.2 A
Max. terminal load (DC-1) ¹⁾ on 1-3 (NC) (Resistive load)	50 V DC, 2 A
Max. terminal load (DC-13) ¹⁾ on 1-3 (NC) (Inductive load)	24 V DC, 0.1 A
Min. terminal load on 1-3 (NC), 1-2 (NO)	24 V DC 10 mA, 24V AC 2 mA
Environment according to EN 60664-1	overvoltage category III/pollution degree 2
Relay 02 Terminal number	4-6 (break), 4-5 (make)
Max. terminal load (AC-1) ¹⁾ on 4-5 (NO) (Resistive load) ^{2),3)}	400 V AC, 2 A
Max. terminal load (AC-15) ¹⁾ on 4-5 (NO) (Inductive load @ cos ϕ 0.4)	240 V AC, 0.2 A
Max. terminal load (DC-1) ¹⁾ on 4-5 (NO) (Resistive load)	80 V DC, 2 A
Max. terminal load (DC-13) ¹⁾ on 4-5 (NO) (Inductive load)	24 V DC, 0.1 A
Max. terminal load (AC-1) ¹⁾ on 4-6 (NC) (Resistive load)	240 V AC, 2 A
Max. terminal load (AC-15) ¹⁾ on 4-6 (NC) (Inductive load @ cos ϕ 0.4)	240 V AC, 0.2 A
Max. terminal load (DC-1) ¹⁾ on 4-6 (NC) (Resistive load)	50 V DC, 2 A
Max. terminal load (DC-13) ¹⁾ on 4-6 (NC) (Inductive load)	24 V DC, 0.1 A
Min. terminal load on 4-6 (NC), 4-5 (NO)	24 V DC 10 mA, 24V AC 2 mA
Environment according to EN 60664-1	overvoltage category III/pollution degree 2

1) IEC 60947 t 4 and 5

The relay contacts are galvanically isolated from the rest of the circuit by reinforced isolation (PELV).

2) Overvoltage Category II

3) UL applications 300 V AC 2 A

Control card, 10 V DC output

Terminal number	50
Output voltage	10.5 V \pm 0.5 V
Max. load	25 mA

The 10 V DC supply is galvanically isolated from the supply voltage (PELV) and other high-voltage terminals.

Control characteristics

Resolution of output frequency at 0-590 Hz	± 0.003 Hz
System response time (terminals 18, 19, 27, 29, 32, 33)	≤2 ms
Speed control range (open loop)	1:100 of synchronous speed
Speed accuracy (open loop)	30-4000 RPM: Maximum error of ±8 RPM

All control characteristics are based on a 4-pole asynchronous motor.

Surroundings

Enclosure type D1h/D2h/D5h/D6h/D7h/D8h	IP21/Type 1, IP54/Type12
Enclosure type D3h/D4h	IP20/Chassis
Vibration test all enclosure types	1.0 g
Relative humidity	5%-95% (IEC 721-3-3; Class 3K3 (non-condensing) during operation
Aggressive environment (IEC 60068-2-43) H ₂ S test	class Kd
Test method according to IEC 60068-2-43 H ₂ S (10 days)	
Ambient temperature (at 60 AVM switching mode)	
- with derating	max. 55 °C ¹⁾
- with full output power of typical EFF2 motors (up to 90% output current)	max. 50 °C ¹⁾
- at full continuous FC output current	max. 45 °C ¹⁾

1) For more information on derating see the Design Guide, section on Special Conditions.

Minimum ambient temperature during full-scale operation	0 °C
Minimum ambient temperature at reduced performance	-10 °C
Temperature during storage/transport	-25 to +65/70 °C
Maximum altitude above sea level without derating	1000 m
Maximum altitude above sea level with derating	3000 m

1) For more information on derating see the Design Guide, section on Special Conditions.

EMC standards, Emission	EN 61800-3, EN 61000-6-3/4, EN 55011, IEC 61800-3 EN 61800-3, EN 61000-6-1/2,
EMC standards, Immunity	EN 61000-4-2, EN 61000-4-3, EN 61000-4-4, EN 61000-4-5, EN 61000-4-6

See the Design Guide, section on Special Conditions.

Control card performance

Scan interval	5 ms
---------------	------

Control card, USB Serial Communication

USB standard	1.1 (Full speed)
USB plug	USB type B "device" plug

⚠ CAUTION

Connection to PC is carried out via a standard host/device USB cable.

The USB connection is galvanically isolated from the supply voltage (PELV) and other high-voltage terminals.

The USB connection is not galvanically isolated from protection earth (ground). Use only isolated laptop/PC as connection to the USB connector on frequency converter or an isolated USB cable/converter.

Protection and Features

- Electronic thermal motor protection against overload.
- Temperature monitoring of the heat sink ensures that the frequency converter trips if the temperature reaches 95 °C ±5 °C. An overload temperature cannot be reset until the temperature of the heat sink is below 70 °C ±5 °C (Guideline - these temperatures may vary for different power sizes, enclosures etc.). The frequency converter has an auto derating function to avoid its heat sink reaching 95 °C.
- The frequency converter is protected against short-circuits on motor terminals U, V, W.
- If a mains phase is missing, the frequency converter trips or issues a warning (depending on the load).
- Monitoring of the intermediate circuit voltage ensures that the frequency converter trips if the intermediate circuit voltage is too low or too high.
- The frequency converter is protected against ground faults on motor terminals U, V, W.

11.3 Fuse Tables

11.3.1 Protection

Branch circuit protection

To protect the installation against electrical and fire hazard, all branch circuits in an installation, switch gear, machines etc., must be short-circuited and over-current protected according to national/international regulations.

Short-circuit protection

The frequency converter must be protected against short-circuit to avoid electrical or fire hazard. Danfoss recommends using the fuses mentioned below to protect service personnel and equipment in case of an internal failure in the frequency converter. The frequency converter provides full short-circuit protection in case of a short-circuit on the motor output.

Overcurrent protection

Provide overload protection to avoid fire hazard due to overheating of the cables in the installation. The frequency converter is equipped with an internal overcurrent protection that can be used for upstream overload protection (UL-applications excluded). See *4-18 Current Limit*. Moreover, fuses or circuit breakers can be used to

provide the overcurrent protection in the installation. Overcurrent protection must always be carried out according to national regulations.

11.3.2 Fuse Selection

Danfoss recommends using the following fuses which will ensure compliance with EN50178. In case of malfunction, not following the recommendation may result in unnecessary damage to the frequency converter.

The fuses below are suitable for use on a circuit capable of delivering 100,000 Arms (symmetrical).

N110-N315	380–500 V	type aR
N75K-N400	525–690 V	type aR

Table 11.5 Recommended Fuses

Power Size	Fuse options							
	Bussman PN	Littelfuse PN	Littelfuse PN	Bussmann PN	Siba PN	Ferraz-Shawmut PN	Ferraz-Shawmut PN (Europe)	Ferraz-Shawmut PN (North America)
N110	170M2619	LA50QS300-4	L50S-300	FWH-300A	20 610 31.315	A50QS300-4	6,9URD31D08A0315	A070URD31KI0315
N132	170M2620	LA50QS350-4	L50S-350	FWH-350A	20 610 31.350	A50QS350-4	6,9URD31D08A0350	A070URD31KI0350
N160	170M2621	LA50QS400-4	L50S-400	FWH-400A	20 610 31.400	A50QS400-4	6,9URD31D08A0400	A070URD31KI0400
N200	170M4015	LA50QS500-4	L50S-500	FWH-500A	20 610 31.550	A50QS500-4	6,9URD31D08A0550	A070URD31KI0550
N250	170M4016	LA50QS600-4	L50S-600	FWH-600A	20 610 31.630	A50QS600-4	6,9URD31D08A0630	A070URD31KI0630
N315	170M4017	LA50QS800-4	L50S-800	FWH-800A	20 610 31.800	A50QS800-4	6,9URD32D08A0800	A070URD31KI0800

Table 11.6 Fuse Options for 380-480 V Frequency Converters

OEM		Fuse options		
VLT Model	Bussmann PN	Siba PN	Ferraz-Shawmut European PN	Ferraz-Shawmut North American PN
N75k T7	170M2616	20 610 31.160	6,9URD30D08A0160	A070URD30KI0160
N90k T7	170M2619	20 610 31.315	6,9URD31D08A0315	A070URD31KI0315
N110 T7	170M2619	20 610 31.315	6,9URD31D08A0315	A070URD31KI0315
N132 T7	170M2619	20 610 31.315	6,9URD31D08A0315	A070URD31KI0315
N160 T7	170M2619	20 610 31.315	6,9URD31D08A0315	A070URD31KI0315
N200 T7	170M4015	20 620 31.550	6,9URD32D08A0550	A070URD32KI0550
N250 T7	170M4015	20 620 31.550	6,9URD32D08A0550	A070URD32KI0550
N315 T7	170M4015	20 620 31.550	6,9URD32D08A0550	A070URD32KI0550
N400 T7	170M4015	20 620 31.550	6,9URD32D08A0550	A070URD32KI0550

Table 11.7 Fuse Options for 525-690 V Frequency Converters

For UL compliance, for units supplied without a contactor-only option, the Bussmann 170M series fuses must be used. See Table 11.9 for SCCR ratings and UL fuse criteria if a contactor-only option is supplied with the frequency converter.

11.3.3 Short Circuit Current Rating (SCCR)

If the frequency converter is not supplied with a mains disconnect, contactor or circuit breaker, the Short Circuit Current Rating (SCCR) of the frequency converters is 100,000 amps at all voltages (380–690 V).

If the frequency converter is supplied with a mains disconnect, the SCCR of the frequency converter is 100,000 amps at all voltages (380–690 V).

If the frequency converter is supplied with a circuit breaker, the SCCR depends on the voltage, see Table 11.8:

	415 V	480 V	600 V	690 V
D6h frame	100,000 A	100,000 A	65,000 A	70,000 A
D8h frame	100,000 A	100,000 A	42,000 A	30,000 A

Table 11.8 Frequency Converter Supplied with a Circuit Breaker

If the frequency converter is supplied with a contactor-only option and is externally fused according to Table 11.9, the SCCR of the frequency converter is as follows:

	415 V IEC ¹⁾	480 V UL ²⁾	600 V UL ²⁾	690 V IEC ¹⁾
D6h frame	100,000 A	100,000 A	100,000 A	100,000 A
D8h frame (not including the N315T4)	100,000 A	100,000 A	100,000 A	100,000 A
D8h frame (N315T4 only)	100,000 A	Consult factory	Not applicable	

Table 11.9 Frequency Converter Supplied with a Contactor

- 1) With a Bussmann type LPJ-SP or Gould Shawmut type AJT fuse. 450 A max fuse size for D6h and 900 A max fuse size for D8h.
- 2) Must use Class J or L branch fuses for UL approval. 450 A max fuse size for D6h and 600 A max fuse size for D8h.

11.3.4 Connection Tightening Torques

When tightening all electrical connections it is very important to tighten with the correct torque. Too low or too high torque results in a bad electrical connection. Use a torque wrench to ensure correct torque. Always use a torque wrench to tighten the bolts.

Frame Size	Terminal	Torque	Bolt size
D1h/D3h/D5h/D6h	Mains Motor Load sharing Regen	19-40 Nm (168-354 in-lbs)	M10
	Earth (Ground) Brake	8.5-20.5 Nm (75-181 in-lbs)	M8
D2h/D4h/D7h/D8h	Mains Motor Regen Load sharing Earth (ground)	19-40 Nm (168-354 in-lbs)	M10
	Brake	8.5-20.5 Nm (75-181 in-lbs)	M8

Table 11.10 Torque for Terminals

Index

A

AC input..... 7, 30
 AC mains..... 6, 7, 8
 AC mains connection..... 30
 AC waveform..... 6, 7
 Accel time..... 38
 Airflow..... 10
 Alarm log..... 41
 Alarm trip..... 63
 Alarm/warning code list..... 65
 AMA..... 60, 67, 70
 AMA with T27 connected..... 53
 AMA without T27 connected..... 53
 Analog input..... 32, 66, 80
 Analog output..... 32, 80
 Analog signal..... 66
 Analog speed reference..... 54
 Application examples..... 53
 Auto mode..... 41
 Auto on..... 42
 Auto On..... 60, 61
 Auto-reset..... 40

B

Basic operational programming..... 37
 Braking..... 60, 68

C

Cable length and cross-section..... 79
 Circuit breaker..... 36
 Closed loop..... 33
 Communication option..... 69
 Conduit..... 13, 36
 Connection, control wiring..... 30
 Control cable..... 31
 Control cable, screened..... 31
 Control card..... 66
 Control card performance..... 82
 Control card, 10 V DC output..... 81
 Control card, 24 V DC output..... 81
 Control card, RS-485 serial communication..... 80
 Control card, USB serial communication..... 82
 Control characteristic..... 82
 Control signal..... 44, 60

Control system..... 6
 Control terminal..... 33, 42, 46, 60, 62
 Control terminal function..... 33
 Control terminal type..... 32
 Control terminals..... 37
 Control wiring..... 11, 13, 14, 36
 Control wiring connection..... 30
 Cooling clearance..... 36
 Current limit..... 38
 Current rating..... 9, 66

D

DC current..... 7, 60
 DC link..... 66
 Definitions, warning, alarm..... 64
 Derating..... 9, 82, 83
 Digital input..... 32, 46, 61, 67, 79
 Digital output..... 81
 Discharge time..... 8
 Disconnect switch..... 37
 Downloading data from the LCP..... 43
 Duct cooling..... 9

E

Electrical installation..... 11
 Electrical noise..... 14
 EMC..... 32, 36, 82
 Equalizing cable..... 31
 External alarm reset..... 55
 External command..... 7, 62
 External controller..... 6
 External interlock..... 47
 External voltage..... 44

F

Fault log..... 41
 Fault message..... 66
 Feedback..... 33, 36, 60, 70
 Floating delta..... 30
 Frame size..... 7
 Frequency converter block diagram..... 7
 Full load current..... 9
 Functional testing..... 6, 38
 Fuse..... 36, 69, 73
 Fusing..... 13, 36

G

Ground connection..... 14, 36
 Ground loop..... 32
 Ground wire..... 14, 36
 Grounded delta..... 30
 Grounding..... 14, 36
 Grounding hazard..... 14
 Grounding, IP20 enclosure..... 15
 Grounding, IP21/54 enclosure..... 15
 Grounding, screened control cable..... 31

H

Hand..... 38, 60
 Hand on..... 38, 42
 Hand On..... 60
 Harmonic..... 7

I

IEC 61800-3..... 82
 Induced voltage..... 13
 Initialisation..... 43
 Input current..... 30
 Input power..... 7, 8, 11, 14, 36, 63, 73
 Input signal..... 33, 44
 Input terminal..... 33, 66
 Input voltage..... 37, 63
 Installation..... 6, 13, 36, 37
 Installation site..... 9
 Installation, electrical..... 11
 Isolated mains..... 30

L

Latched start/stop inverse..... 54
 Leakage current (>3.5 mA)..... 14
 Local control..... 40, 42, 60
 Local control panel..... 40
 Local mode..... 38
 Local operation..... 40
 Local start..... 38
 Local-control test..... 38

M

Main menu..... 41, 44
 Mains..... 13
 Mains supply (L1, L2, L3)..... 79

Mains voltage..... 41, 42, 60
 Mechanical brake control..... 57
 Mechanical installation..... 9
 Menu key..... 40, 41
 Menu structure..... 42, 47
 Motor cable..... 13, 16, 30
 Motor connection..... 16
 Motor current..... 7, 41, 70
 Motor data..... 37, 38, 67, 70
 Motor frequency..... 41
 Motor output (U, V, W)..... 79
 Motor power..... 13, 41, 70
 Motor protection..... 13, 83
 Motor rotation..... 41
 Motor rotation check..... 30
 Motor speeds..... 37
 Motor status..... 6
 Motor thermistor..... 56
 Motor wiring..... 11, 13, 36
 Mounting..... 36
 Multiple frequency converters..... 13, 16

N

Navigation key..... 40, 42, 60
 Navigation keys..... 37, 44
 Noise isolation..... 11, 36

O

Open loop..... 33, 44, 82
 Operation key..... 42
 Optional equipment..... 6, 37
 Output current..... 60, 66, 81
 Output signal..... 47
 Overcurrent..... 61
 Overload protection..... 9, 13
 Overvoltage..... 38, 61

P

Parameter menu structure..... 48
 Parameter setting..... 42
 Parameter Settings..... 46
 PELV..... 30, 53, 81
 Phase loss..... 66
 Potentiometer..... 55
 Potentiometer reference..... 59
 Power..... 14

Power connection.....	14	Smart Application Set-up (SAS).....	37
Power factor.....	7, 16, 36	Specification.....	6
Power rating.....	7	Speed reference.....	33, 39, 44, 53, 55, 60
Pre-installation check list.....	9	Start/stop.....	58
Preset speeds.....	55	Start/stop command.....	54
Product overview.....	4	Start-up.....	6, 43, 44, 73
Programming.....	6, 37, 38, 40, 41, 42, 47, 52, 66	Status display.....	60
Protection.....	83	Status messages.....	60
Protection and features.....	83	Status mode.....	60
Pulse input.....	80	STO.....	33
Pulse start/stop.....	54, 58	Stop command.....	61
Q		Supply voltage.....	30, 32, 69, 80
Quick menu.....	41, 44	Surroundings.....	82
Quick set-up.....	37	Switching frequency.....	61
R		System feedback.....	6
Ramp-down time.....	38	T	
Ramp-up time.....	38	Temperature limit.....	36
Reference.....	41, 44, 53, 60, 61	Terminal 53.....	33, 44
Relay output.....	32, 81	Terminal 54.....	33
Remote command.....	6	Terminal location, D1h.....	16
Remote programming.....	52	Terminal location, D2h.....	18
Remote reference.....	61	Terminal programming.....	33
Reset.....	40, 42, 43, 62, 63, 66, 71, 83	Terminal programming example.....	46
Restore.....	43	Thermal protection.....	8
Restoring default setting.....	43	Thermistor.....	30, 53, 67
Restoring Default Settings.....	43	Thermistor control wiring.....	30
Reversing.....	55	Torque characteristic.....	79
RFI filter.....	30	Torque limit.....	38
RMS current.....	7	Torque, terminals.....	85
RS-485.....	33, 56	Transient protection.....	7
Run command.....	39	Trip function.....	13
Run permissive.....	61	Troubleshooting.....	6, 66, 73
S		U	
Safe Torque Off.....	33, 54	Unintended start.....	43
Screened control cable.....	31	Uploading data to the LCP.....	43
Screened control cable, using.....	31	V	
Serial communication.....	6, 31, 32, 33, 42, 60, 61, 63	Voltage imbalance.....	66
Setpoint.....	61	Voltage reference via potentiometer.....	59
Set-up.....	41	W	
Shielded cable.....	11, 36	Warning, alarm definitions.....	64
Shielded wire.....	13	Wire type, rating.....	14
Short circuit.....	67	Wiring, control terminal.....	33
Sleep mode.....	61		



www.danfoss.com/drives

.....
Danfoss can accept no responsibility for possible errors in catalogues, brochures and other printed material. Danfoss reserves the right to alter its products without notice. This also applies to products already on order provided that such alterations can be made without subsequential changes being necessary in specifications already agreed. All trademarks in this material are property of the respective companies. Danfoss and the Danfoss logotype are trademarks of Danfoss A/S. All rights reserved.
.....

Danfoss A/S
Ulsnaes 1
DK-6300 Graasten
www.danfoss.com/drives

