



Digitized Automation for a Changing World

Delta AC Servo Drive & Motor ASDA-B3 Series

Delta Standard Servo System ASDA-B3 High Efficiency, User-Friendly, and Stable

The high tolerance and stable operation of the Delta standard servo system ASDA-B3 series creates a highly efficient and user-friendly operation environment with precise motion control functions that optimize production efficiency and output value.

With the best motion control solutions, Delta boosts industry momentum and works with customers to create an innovative future.





Table of Contents

Optimized Performance	1
Various Motion Functions	3
EtherCAT Communication Functions	5
PROFINET Communication Functions	7
Vibration Suppression Functions	9
Self-Diagnosis and Adaptation	10
Energy-Saving and Compact Size	11
Battery-Less Absolute Encoder	12
Multiple Selections	13
User-Friendly Software Interface	14
Applications	16
Servo Drive & Accessories	18
Servo Drive Interface	19
Accessories	20
Servo System Combination Table	21
Servo Drive Model Name	31
Servo Drive Specifications	32
Servo Motor Model Name	37
ECM-B3 Series Servo Motor Specifications	38
ECM-A3 Series Servo Motor Specifications	60
Control Mode Wiring	65
Ordering Information	74
Servo Drive Standards	91

Optimized Performance

High Response Bandwidth

- Higher responsiveness: From 0.5kHz of the ASDA-B2 series to 3.1kHz of the ASDA-B3 series
- Increased productivity: Settling time reduced by 40%

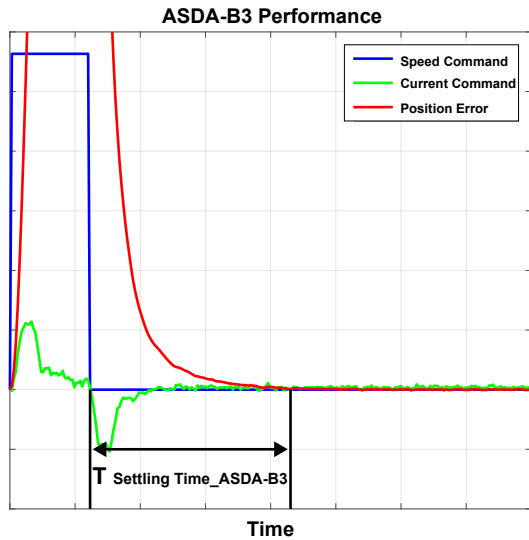
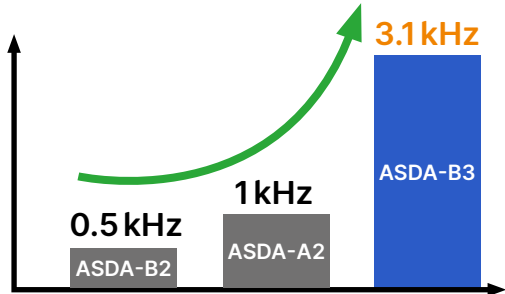

Higher Load Tolerance

- Enhances positioning precision and optimizes the system
- Higher response bandwidth with the same load conditions

	ASDA-B2	ASD-B3	ASDA-B2	ASD-B3	ASDA-B2	ASD-B3
Actual Load Inertia Ratio	30 times		50 times		70 times	
Speed Loop Bandwidth in Position Mode	Approx. 150Hz	Approx. 250Hz	Approx. 30Hz	Approx. 150Hz	Max. performance	Approx. 20Hz

24-bit Absolute Encoder

- Enhances positioning precision with a resolution of 16,777,216 pulses per revolution
- Stable operation at low speeds improves machine performance
- Absolute encoder retains the motor's position when the power is off

16,777,216 pulses for one single turn

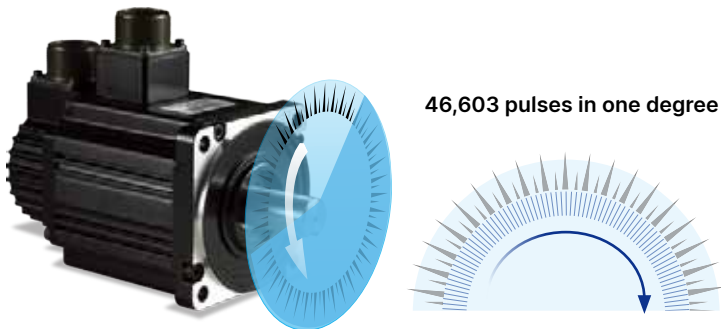

Low Cogging Torque

The cogging torque is 50% of previous models which increases the smoothness of constant speed operation and low speed machining

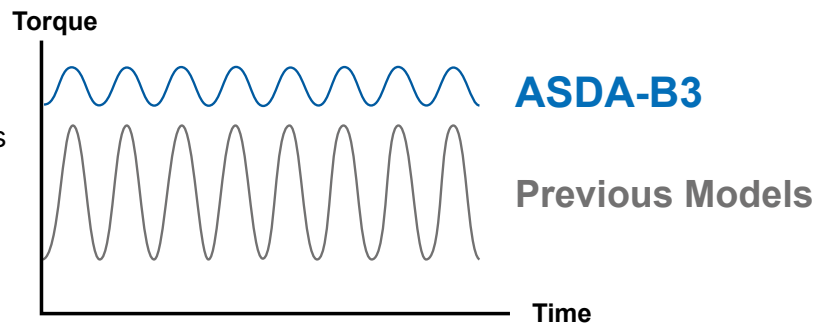

Increased Speed and Torque

- Motor speed increased to 6,000 rpm
- Torque overload ratio increased to 3.5 times and the time required for acceleration and deceleration is shortened
- Significantly increases productivity and efficiency

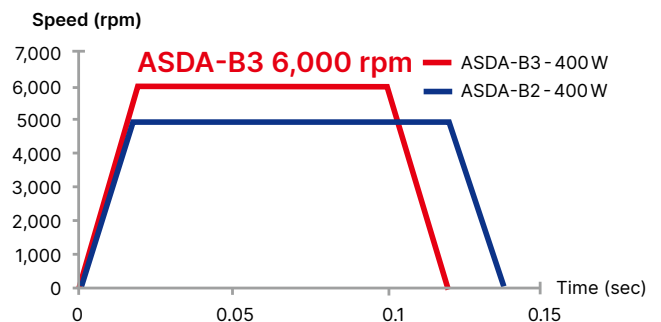
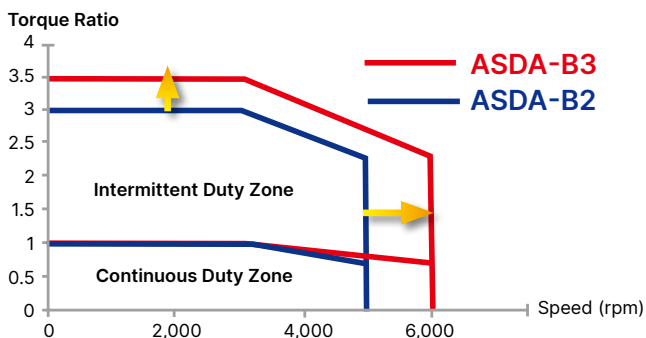

Safe Torque Off (STO) Function

- Built-in STO function ensures personnel safety
- Complies with IEC/EN 61800-5-2
- SIL2 Level

Note: ASDA-B3A 400V certification in process

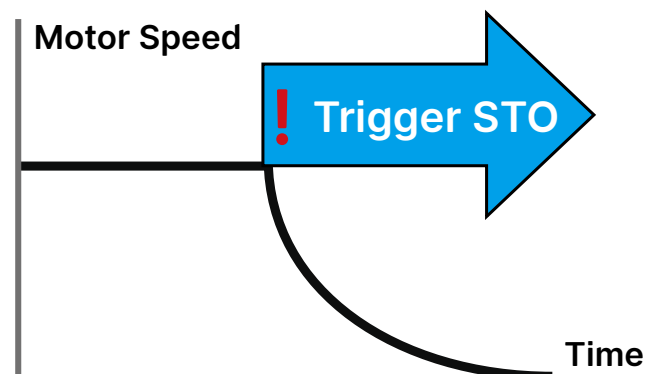

Various Motion Functions

PR Mode

- Supports up to 99 PR paths for flexible motion command planning
- Intuitive operation interface with graphics
- Homing modes, position commands, and speed commands
- Overlap command, interrupt command, jump command, and parameter settings

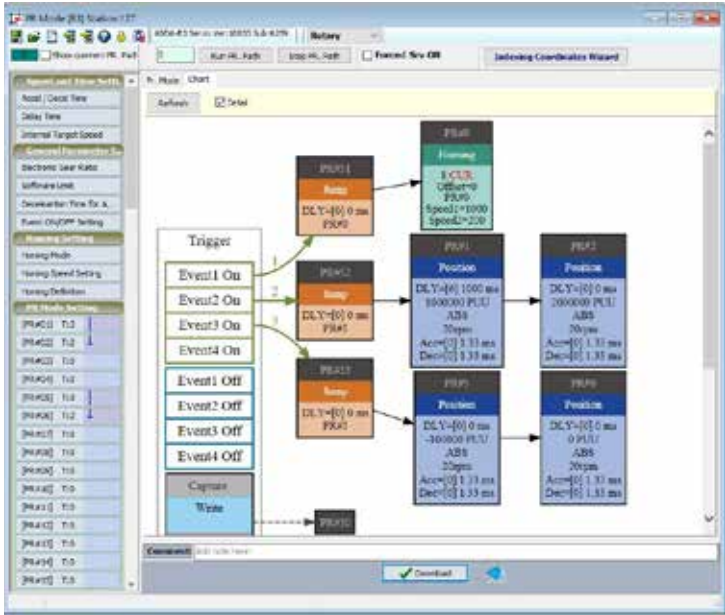

High-Speed Capture Function

- Supports the Capture function for instantly capturing position coordinates with one set of DI
- Supports the Touch Probe function with two sets of DIs in the EtherCAT communication mode

Note:
 Capture function: DI4 (B3-F, B3-M), DI7 (B3-L)
 Touch Probe function: DI1, DI2 (B3-E)

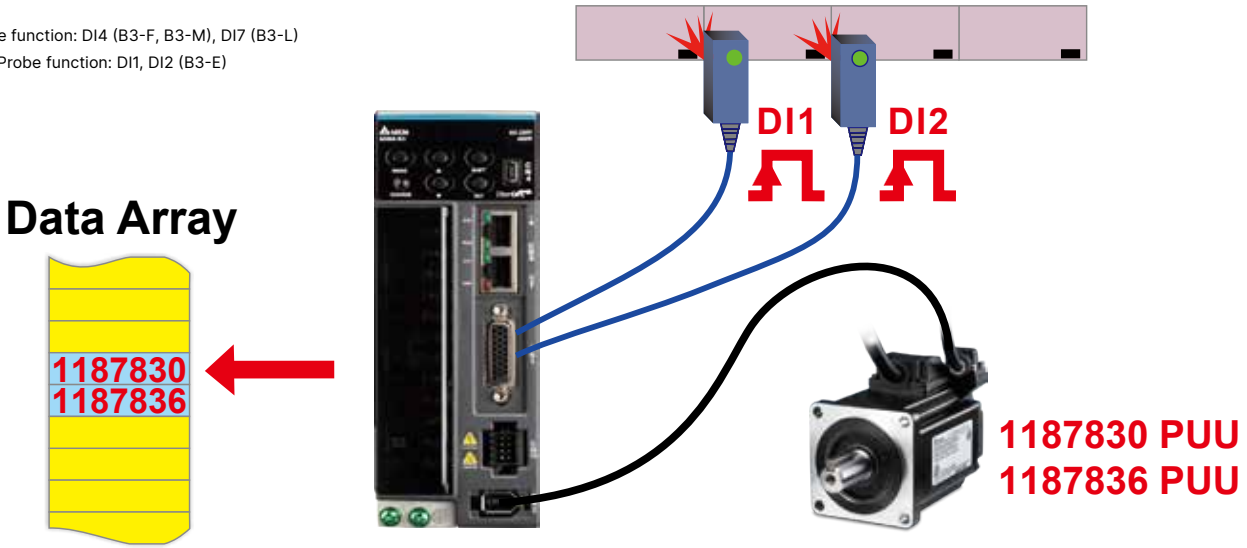

Analog Feedback PID Control

- Supports analog signal input
- Real-time and precise PID control enabled by the analog signals from the external sensor improves production yield and processing performance

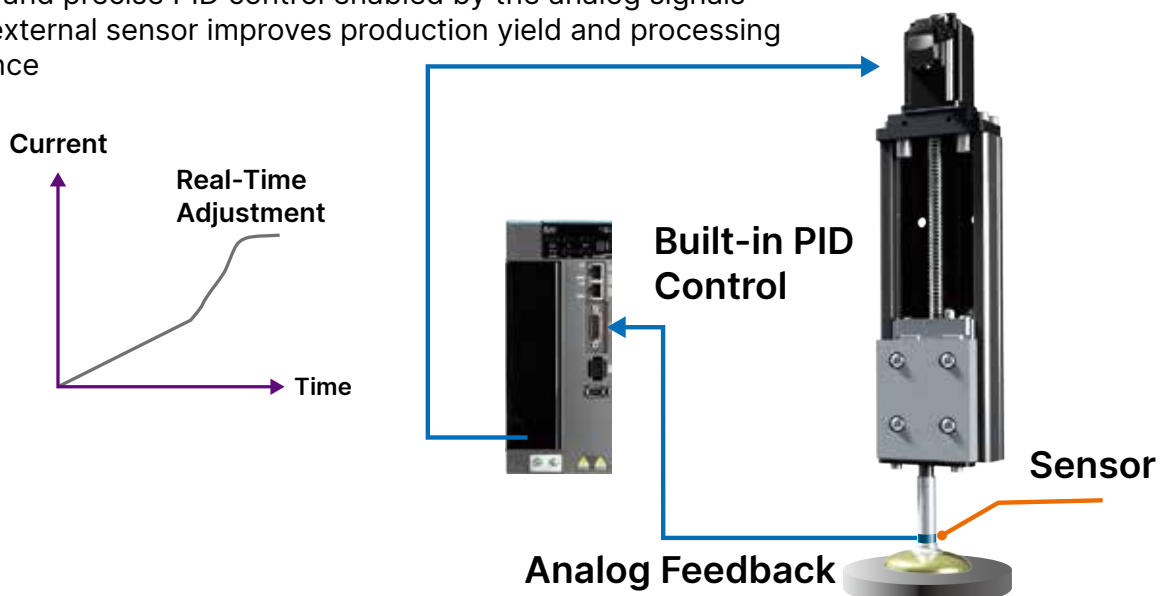

EtherCAT Communication Functions

Complies with the IEC 61158 and IEC 61800-7 fieldbus standards

Shorter Synchronization Cycle

- The synchronization cycle of the ASDA-B3 series is 125 μ s, which is 8 times faster than that of the ASDA-A2 series

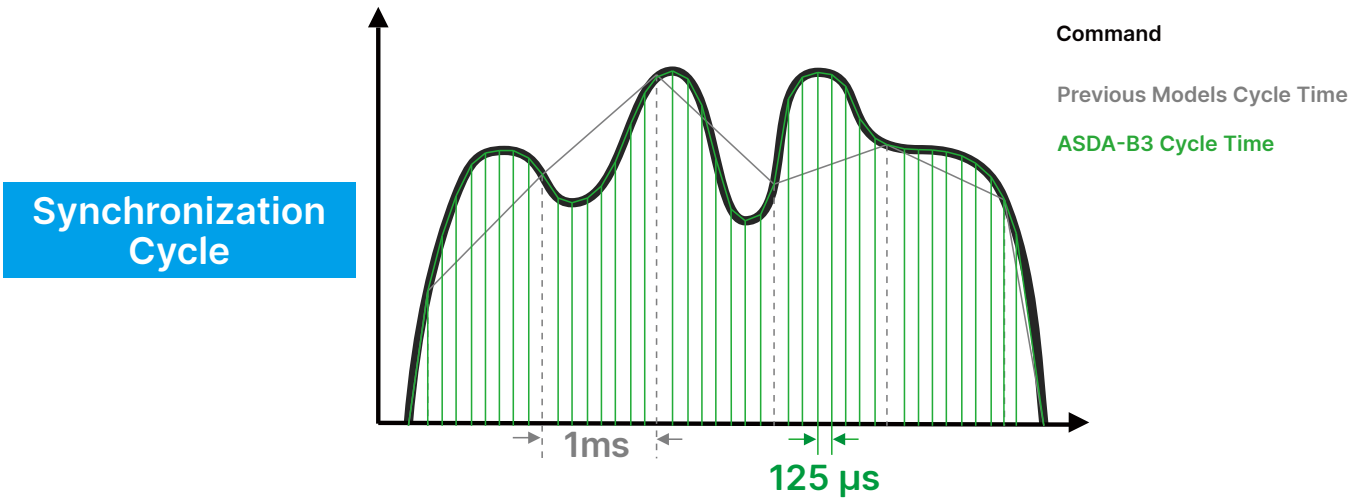

Simplified Wiring

In contrast to single-axis pulse wiring which is complicated and difficult to repair, the EtherCAT high-speed communication greatly reduces the wiring and inspection time. It is suitable for multi-axis control and can also connect remote I/O modules with a single wiring.

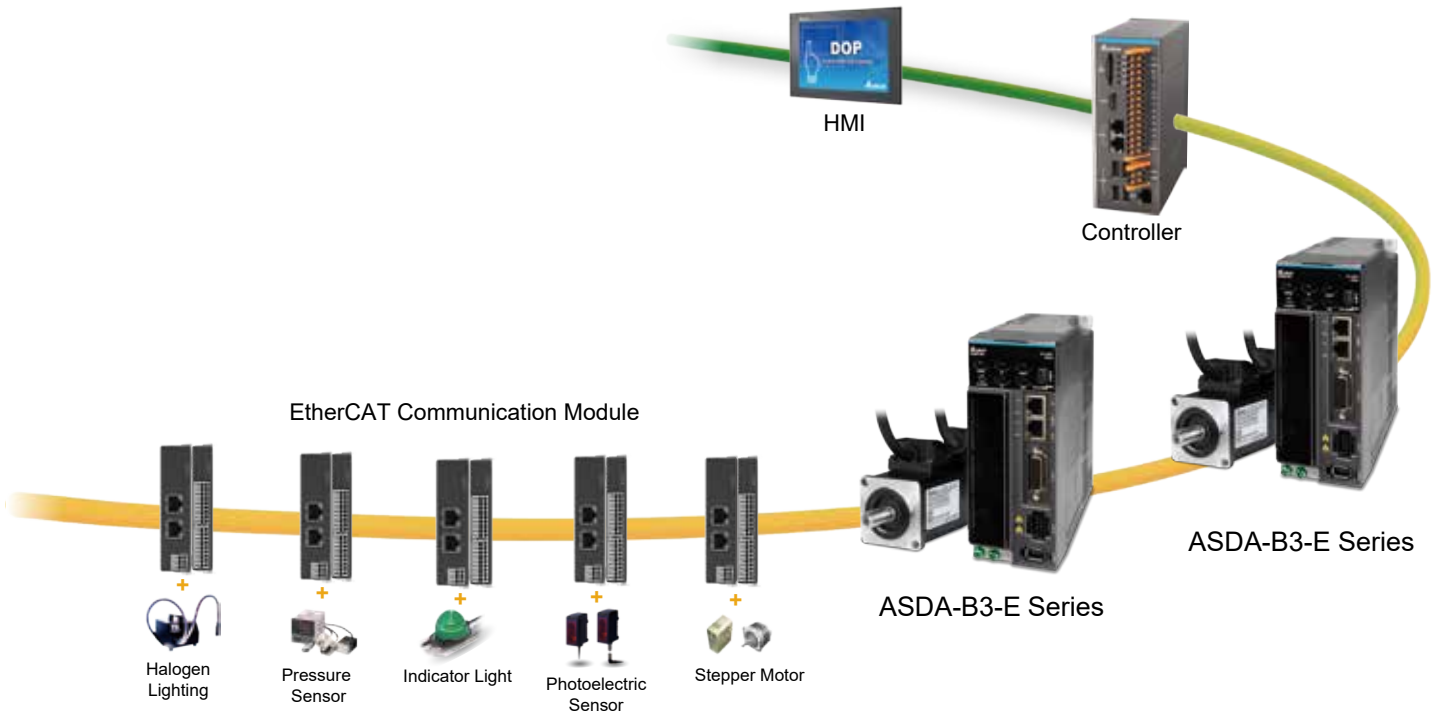

Longer Connection Distance

The maximum distance between two servo stations is 50m and a maximum of 65,536 axes can be connected

Compatible with Previous Models

The ASDA-B3 series models are compatible with the ASDA-A2 and ASDA-A3 series

Note: The communication cycle of the ASDA-A2 series is 1ms, so when previous and new models are used together, the set value cannot be lower than this specification

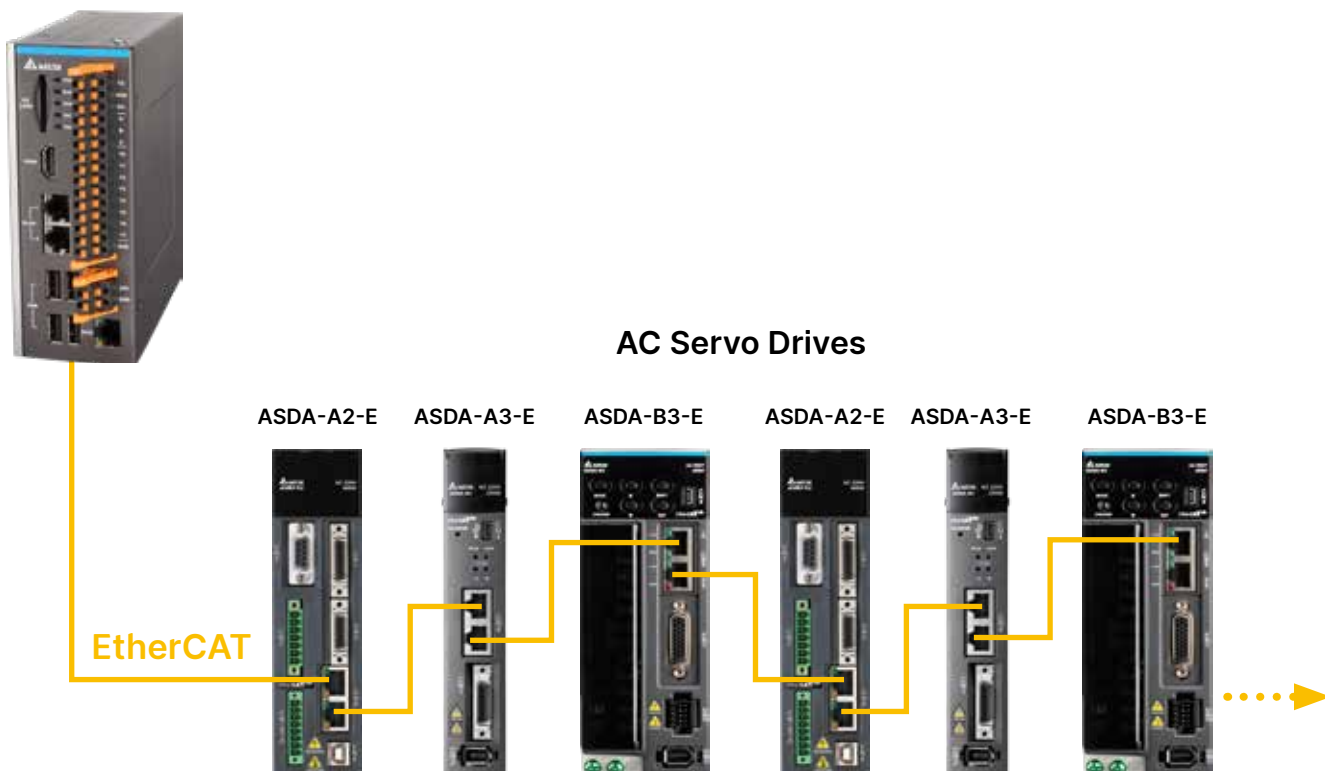

PROFINET Communication Functions

Complies with IEC 61158 and IEC 61784 standards

Simple Wiring & Cost Efficiency

- The open industrial Ethernet communication protocol can complete various data transmissions through the bus and also supports various topologies to meet the needs of different applications as well as intensive parameter synchronous allocation to I/O signal transmissions, achieving smooth data transmission and security protection mechanisms.

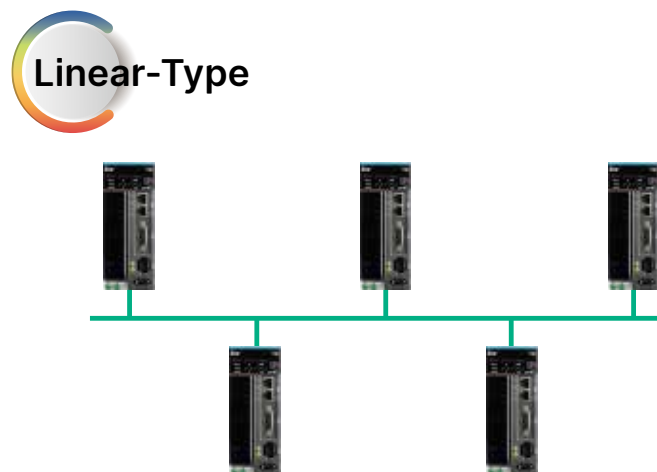
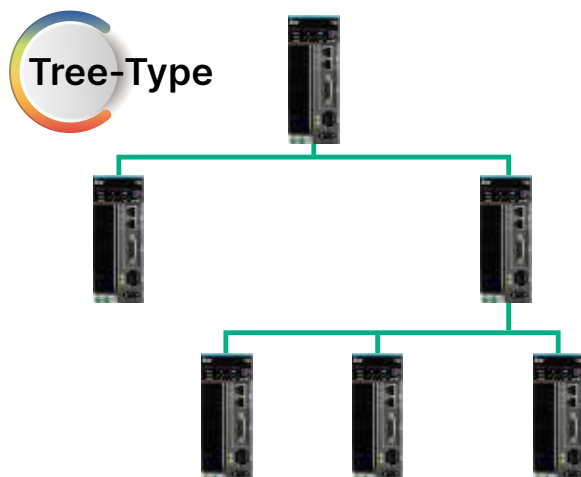
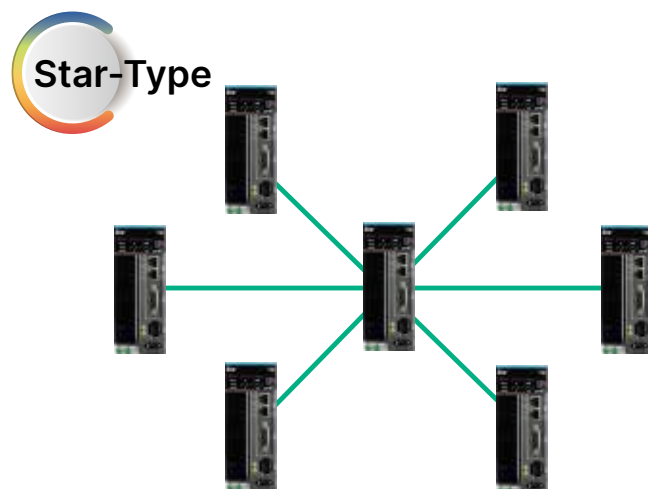
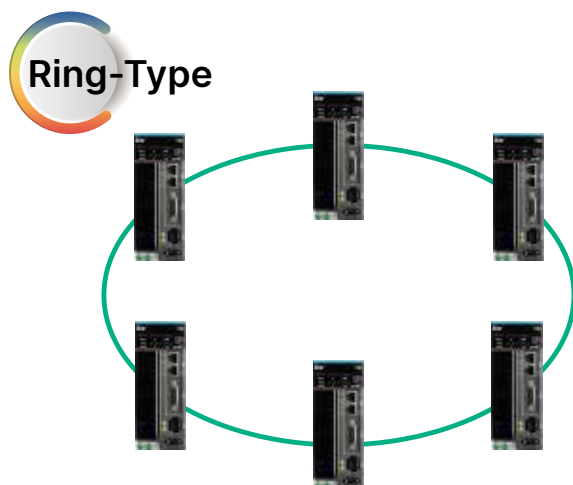

Shorter Synchronization Cycle

- The ASDA-B3A Series has a 1 ms synchronization cycle

Long Connection Distance

- The longest distance between two stations can reach 50 m, and the servo allows a maximum number of serially connected axes of 65,536 axes

Supports Communication Protocol

RT: Real-time communication protocol for PROFINET IO exchange applications.
Min. response time is 1 ms

IRT: Isochronous real-time communication protocol is based on the topology structure to achieve optimal synchronization of PROFINET IO communication and equipment. Min. response time is 1 ms

Message Function

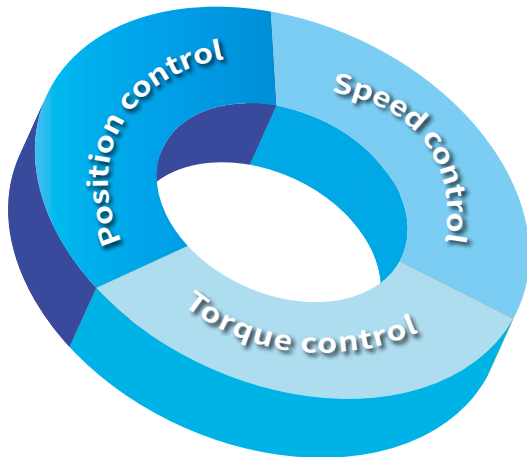

Position control

Basic positioning control (111)
Cycle synchronized positioning control (3, 102, 105)

Speed control

Basic speed control (1)
Speed regulation control (111)
Cycle synchronized speed control (3, 102, 105)

Torque control

Torque limit control (3+750, 102+750, 105+750) *

*Under development

Controller

PROFINET



ASDA-B3A-P models

PROFINET

PROFINET



Automotive



Semiconductor



Medical



Lithium battery



Logistics

Vibration Suppression Functions

Vibration Elimination

- Low frequency vibration suppression applies Delta's unique algorithm to adjust low rigidity machine structures
- Two sets of built-in vibration elimination settings reduce jitter at the machine endpoint while maintaining a good command response

Without Vibration Elimination - Machine endpoint vibrates when settling

With Vibration Elimination - Machine endpoint is stable when settling

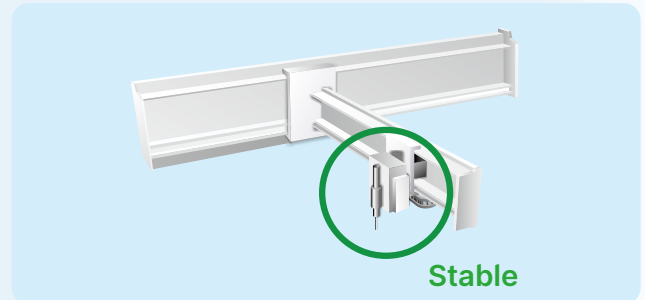
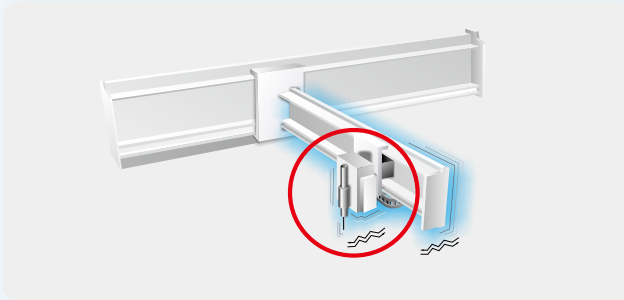

Advanced Notch Filter

- High frequency resonance suppression increased from 3 sets to 5 sets compared with previous models
- Filter bandwidth increased to 5,000 Hz
- Automatically searches for the resonance frequency point and completes the resonance suppression; this reduces the time by 70% compared with previous models and is less likely to damage the machine

Attenuation Rate

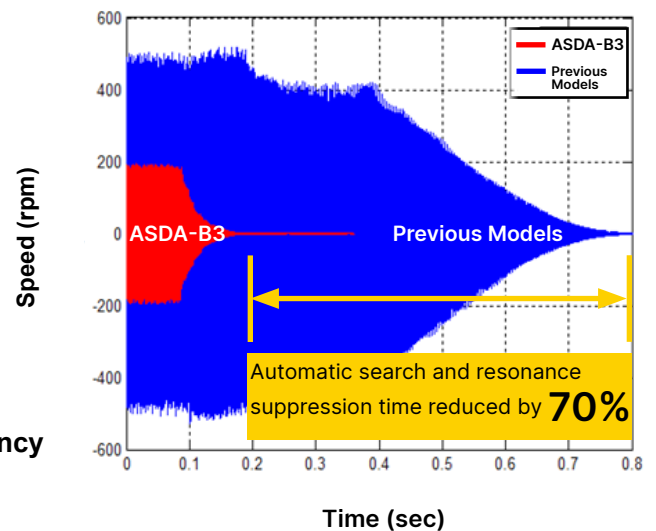
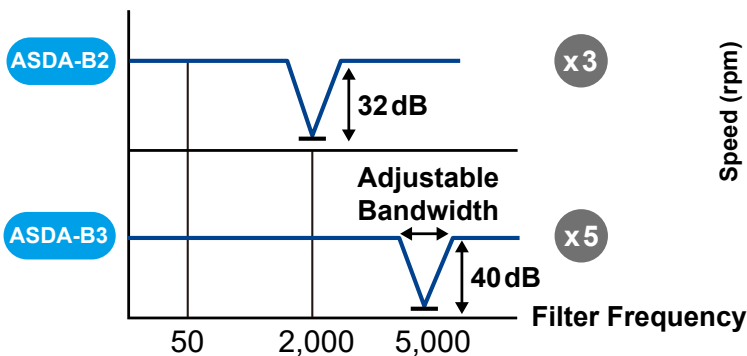

Self-Diagnosis and Adaptation

Outstanding Self-Adjusting Capability

- Dedicated algorithm allows easy tuning with simple settings, which improves the efficiency of equipment assembly and testing
- Suitable for applications with flexible machine structures and large variations in inertia

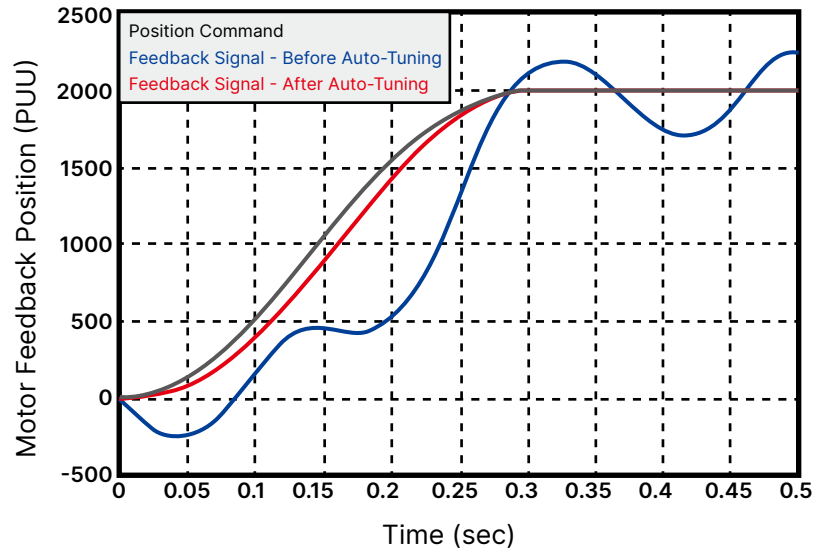

System Analysis Tool

Mechanical Stiffness Diagnosis

- Diagnoses the mechanism elasticity and damping coefficient, and converts the machine structure characteristics into data
- Ensures consistency of mass production machines through data collection

Frequency Domain Response Analysis

- Ensures system stability
- Compares the phases before and after gain adjustment to ensure the safety margin of the system

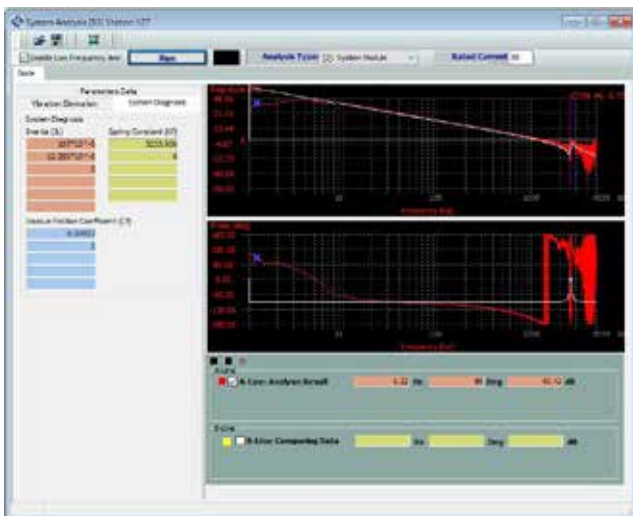

Energy-Saving and Compact Size

Compact Size

- The size of the servo drive is reduced up to 20%, so it requires less space in the distribution board which meets the need for more compact equipment
- The size of the servo motor is reduced up to 31% for less space and cost efficiency

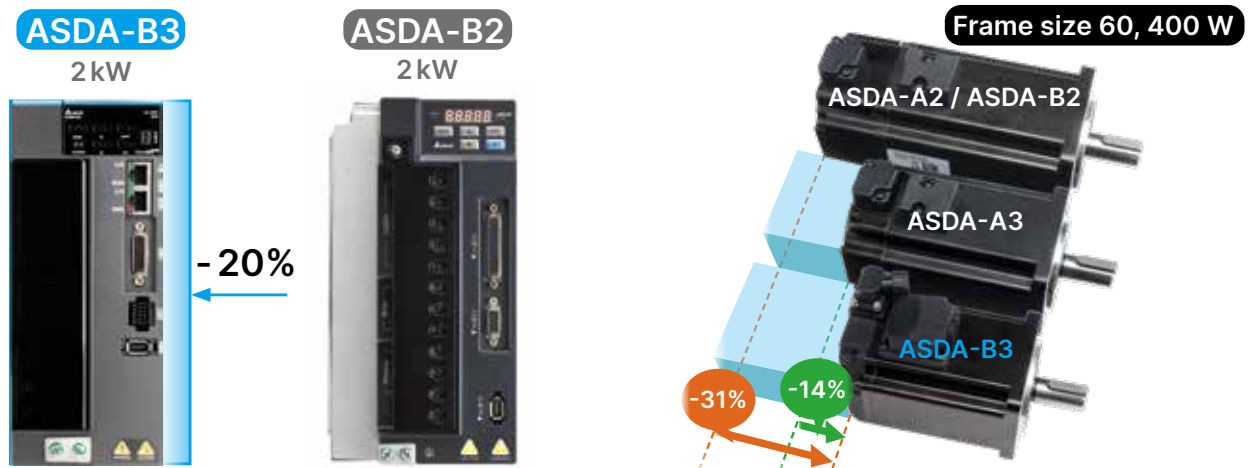

Common DC Bus

- The servo drives can share the DC Bus to reuse regenerative energy for reducing energy consumption
- When multiple servo drives share the common DC Bus, fewer regenerative resistors are required for cost efficiency

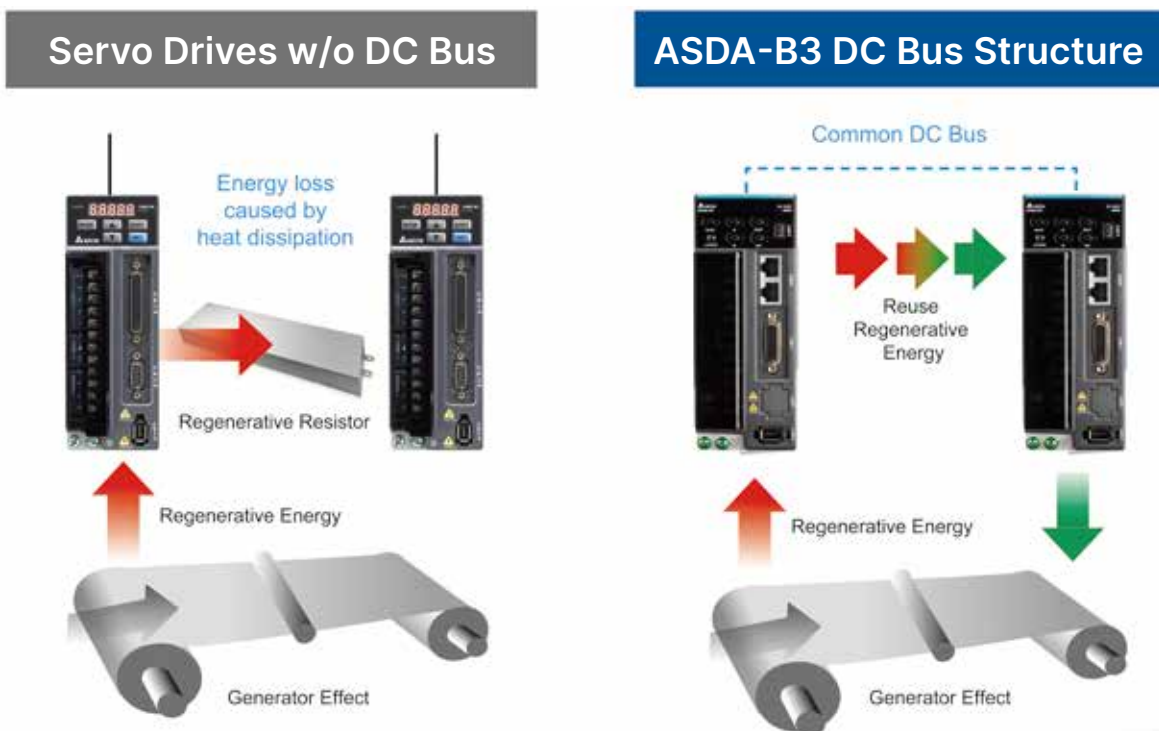

Battery-Less Absolute Encoder

- Electromagnetic induction: When the power is off, the magnet on the encoder shaft rotates. The magnetic field changes are used to induce the electrical energy generated by the Wiegand wire coil to record the number of turns of the encoder for final absolute position
- No gear set: As it records laps for a long period, problems with gear life and mechanism will occur
- No battery pack: Reduces battery maintenance time, avoids battery exhaustion and anomalies, avoids lithium battery transportation

Reduced Cost & Maintenance

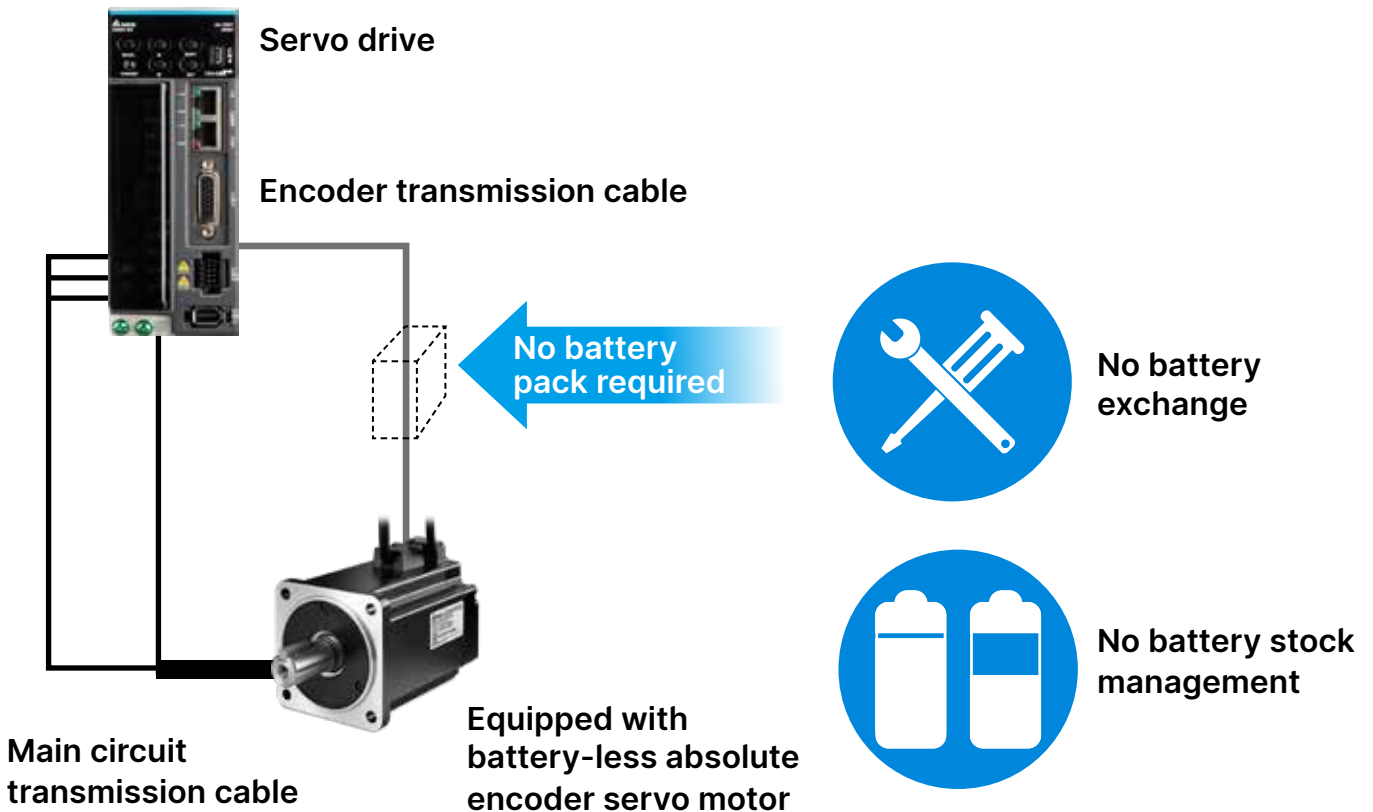

Multiple Selections

High Resolution Encoder

- High resolution for more precise positioning
- The incremental encoder can retain the single-turn absolute position without the need to execute homing after cycling the power
- After the absolute encoder is powered off, the number of turns and position are retained
- 24-bit optical encoder: The encoder is lighter and thinner with the reflective sensor technology; the exclusive optical sensor compensation function improves product reliability
- 17-bit magnetic encoder: The magnetic induction technology improves the capability to prevent vibration and increases the oil resistance level

Optical Encoder

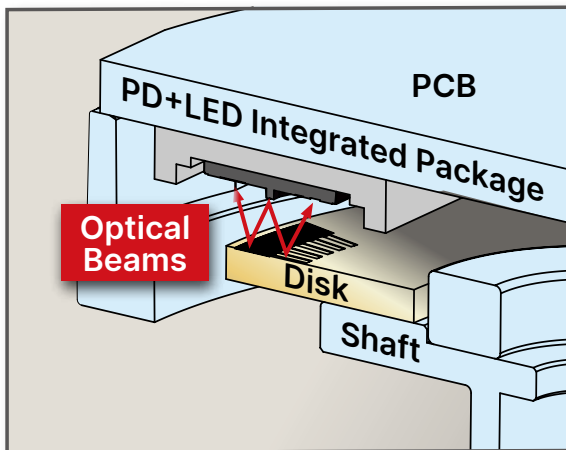

Magnetic Encoder

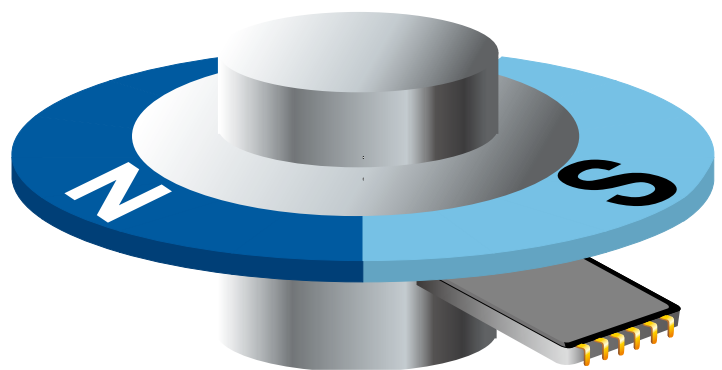

High Compatibility

- Compatible with the ASDA-A2 / ASDA-B2 / ASDA-A3 series motors for easier replacement
- Motors of high, medium, and low inertia are available for different applications

High inertia motor: Suitable for applications that require speed stability or resistance to external forces

Medium inertia motor: Suitable for applications with general mechanical equipment

Low inertia motor: Suitable for high-speed positioning and high response applications



ECM-B3 Motor



ECM-A3 Motor



ECMA/ECMC Motor

User-Friendly Software Interface

Function List Tree View

- Well-organized function list for quick access
- Expandable and collapsible nodes for easier and more efficient operation

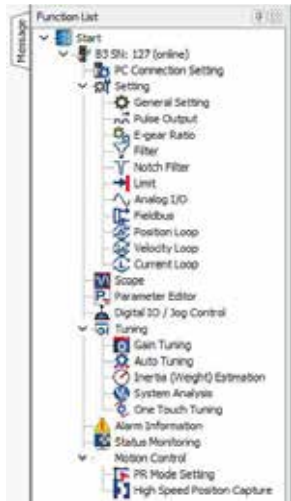

Graphical Parameter Setting

- Intuitive graphic illustrations for gain adjustment and parameter settings

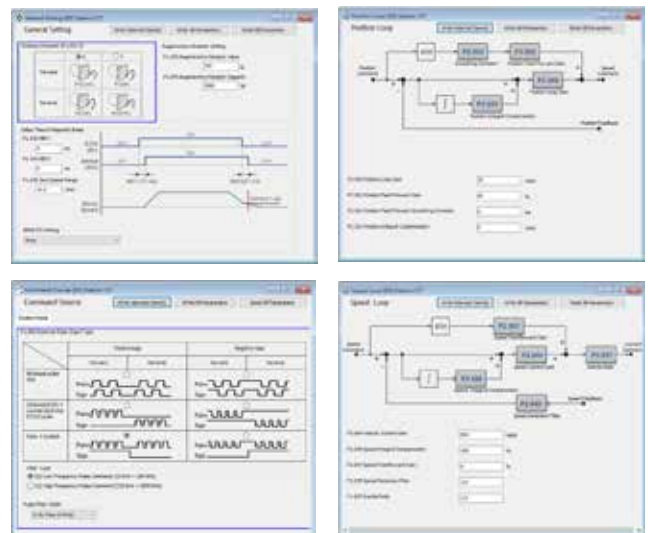

Auto-Tuning Function

- Step-by-step and conversational UI for servo gain adjustment



Advanced Gain Adjustment Function

- Provides advanced gain adjustment modes for fine tuning according to different applications and operating characteristics
- Step-by-step software interface to guide users



User-Friendly Software Interface

System Analysis Interface

- Speed Open-Loop Mode**

Determines if the current system is the most optimized and thus improves the design

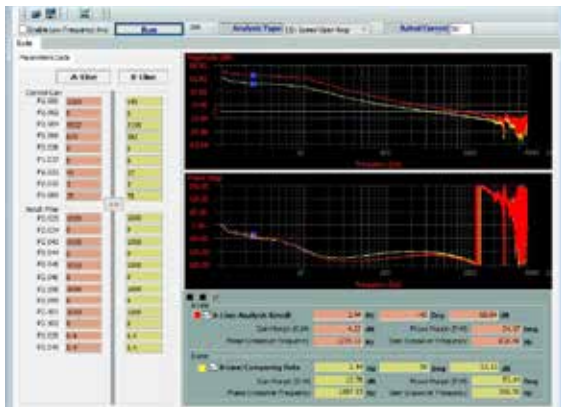

- System Module Mode**

Measures the mechanical stiffness of the mechanism in this mode

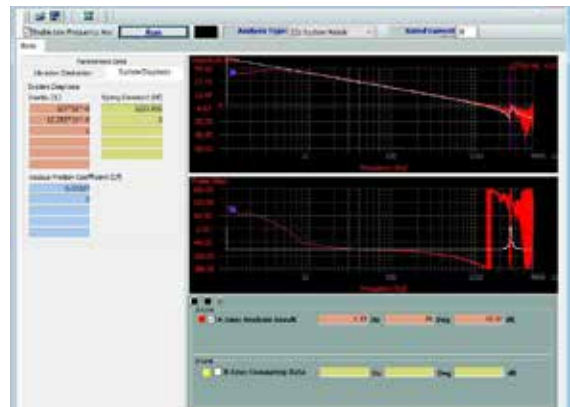

Oscilloscope Function

- Maximum of 8 channels with 16-bit data size and update frequency of 8 kHz
- 4 high-resolution channels with 32-bit data size and update frequency of 8 kHz
- 4 channels of high sampling rate with 16-bit data size and update frequency of 16 kHz
- Drag the cursor to specify the area for instant FFT (Fast Fourier Transform) and RMS calculation
- Set the triggering conditions for collecting data

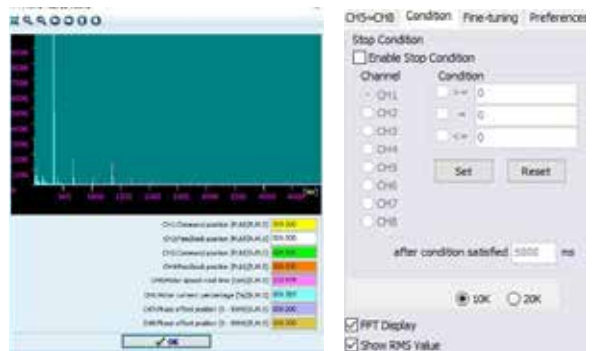
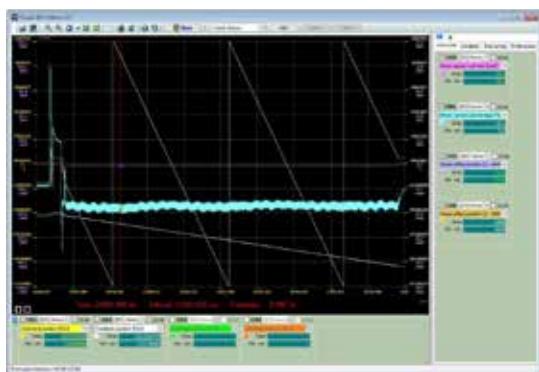

Graphical PR Path Programming Interface

- Graphical PR procedures with detailed settings for better command programming and editing

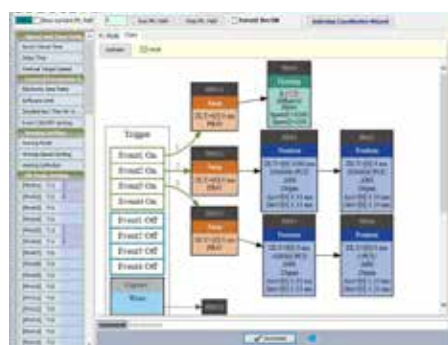

Applications

AOI (Automatic Optical Inspection) System

- Shorter setting time of ASDA-B3 shortens the detection time which also increases the production capacity

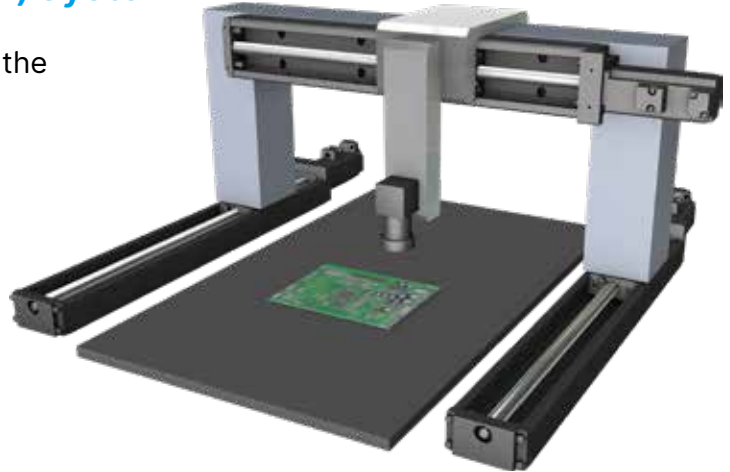

Tool Magazine and Turret

- Shorter response time of ASDA-B3 significantly reduces the tool changing time
- New communication trigger function for the tool magazine increases the number of tools without occupying DI points
- Common DC Bus function reduces the use of regenerative resistors and improves the power consumption efficiency



Wafer Pick and Place Machine

- Analog feedback of the PID control with external sensors provides precision control of downward pressure
- Two-stage downward motion planning with high speed and soft landing improves productivity and yield

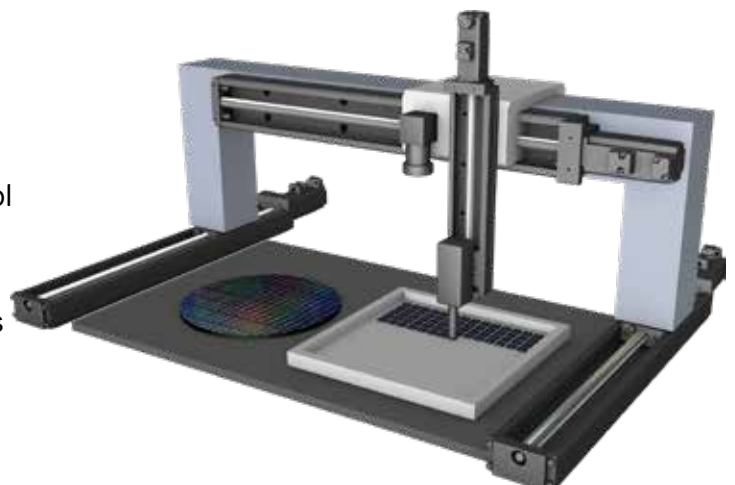

Applications

Machine Tool

- Low cogging torque for more stable machining
- Advanced friction compensation function for better performance when changing directions
- Two-degrees-of-freedom control architecture for optimized trajectory tracking

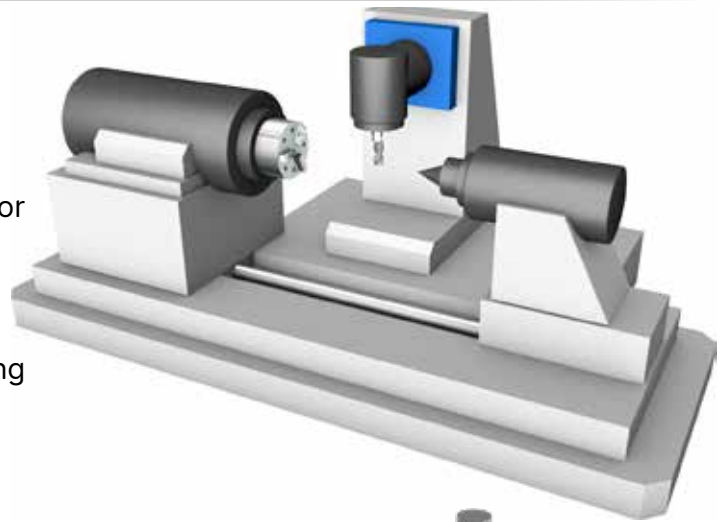

Diamond Cutting Machine

- High inertia motor facilitates the diamond polishing process with high precision and stability
- Low cogging torque for higher machining stability
- Two-degrees-of-freedom control architecture for optimized trajectory tracking

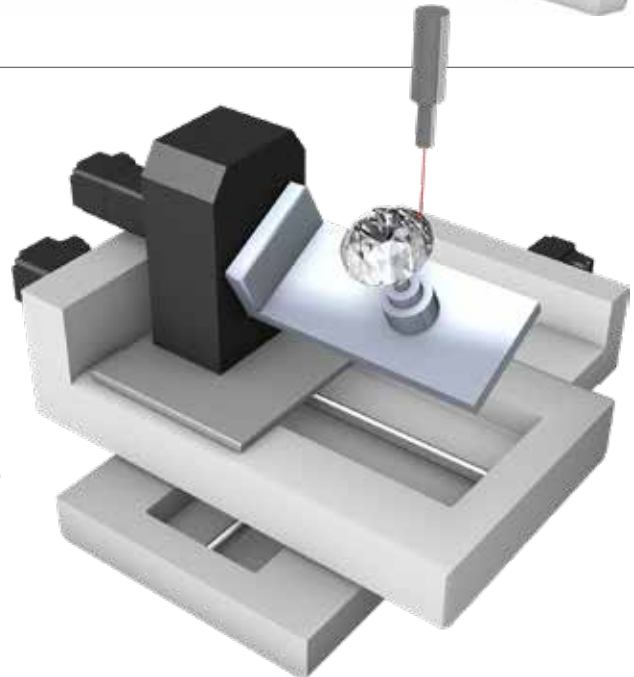

Winding Machine

- Communication type servo drives support the analog input function, facilitating multi-axis communication for tension control
- High-speed fieldbus with the communication cycle of 125 μ s for better synchronization between multiple axes
- Stable tension control with acceleration and deceleration S-curve

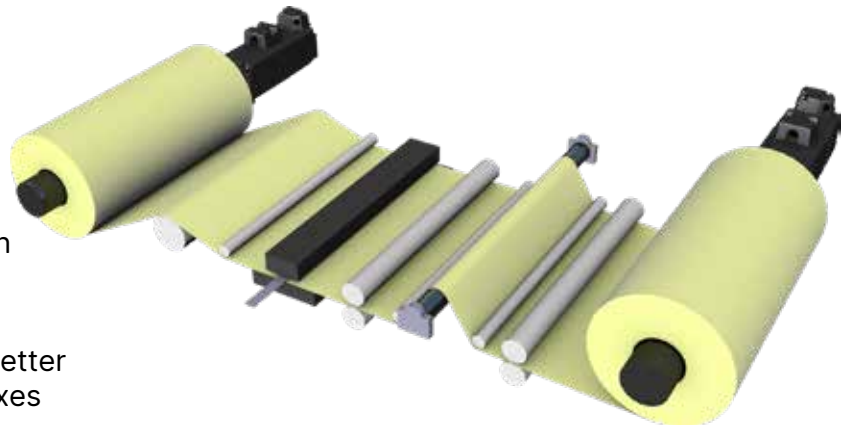

Servo Drive & Accessories

Power Supply

220V
 100 W - 1.5 kW Single / Three-phase 200 - 230V
 2 kW - 3 kW Three-phase 200 - 230V
 400V
 1 - 7.5kW Three-phase 380 - 440V

No Fuse Braker (NFB)

Protects the drive from instant maximum current due to power ON/OFF or electrical shorts

Magnetic Contactor (MC)

When an anomaly occurs, the ALARM notification output by the servo drive can control the magnetic contactor to cut off the power.

3 Main Circuit Power (RST)

4 Control Circuit (L1c L2c)

5 Regenerative Resistor Port (P⊖DC)

Regenerative Resistor

6 Servo Drive Output (UVW)

Power Connector (P.58)
 Power Cable (P.59 - P.62)

1

2



8 Mini USB Port (CN4)

Connects PC for software operation
 Connects with ASDA-SOFT with standard USB Mini connection cable
 Mini USB Communication Module (P.67)



9 COM Port Connector (CN3/CN6)

CN3 CANopen Communication Cable (P.64)
 CN3 CANopen Distribution Box (P.65)
 CN3 RS-485 Tap (P.65)
 CN3 RS-485 / CANopen Terminal Resistor (P.66)
 CN6 DMCNET Terminal Resistor (P.66)

10 I/O Connector (CN1)

Terminal Block Module (P.64)
 CN1 Connector (P.65)
 CN1 Quick Connector (P.65)

11 STO (CN10)

B3A models only

12 Encoder Connector (CN2)

Encoder Connector (P.62)
 Encoder Cable- Incremental Type (P.62)
 Encoder Cable- Absolute Type (P.63)



Note: Under high-interference environment, installing a USB isolator is recommended (Delta's product model: UC-ADP01-A)

Servo Drive Interface

No.	Name	Description
①	-	7-segment display
②	CHARGE	Power indicator
③	RST	Main circuit terminal; connects to the power supply (200 - 230 V _{AC} , 50/60 Hz)
④	L _{1c} , L _{2c}	Control circuit terminal; connects to single-phase power supply (200 - 230 V _{AC} , 50/60 Hz)
⑤	Regenerative Resistor	Connects to an external regenerative resistor, external regenerative braking unit, or the built-in regenerative resistor
⑥	UVW	Servo drive current output; connects to the motor power connector U, V, W. Do not connect to the main circuit power. Incorrect wiring will cause damage to the servo drive.
⑦	Ground Terminal	Connects to the ground wire for the power and servo motor
⑧	CN4	USB connector (Mini USB); connects to PC
⑨	CN3	Modbus communication port (B3-L/B3A-L)
	CN3	CANopen high-speed communication port (B3-M/B3A-M)
	CN6	DMCNET high-speed communication port (B3-F/B3A-F)
	CN6	EtherCAT high-speed communication port (B3-E/B3A-E)
⑩	CN1	I/O signal interface; connects to the PLC or controls I/O
⑪	CN10	STO connector; only available on B3A models
⑫	CN2	Encoder connector; connects to the encoder of the servo motors

Accessories

Power Cables

- 3 m, 5 m, 10 m, and 20 m standard cables are available
- Standard power connectors and IP67 waterproof connectors are available
- With options of brake and without brake

Encoder Cables

- 3 m, 5 m, 10 m, and 20 m standard cables are available
- Standard encoder connectors and IP67 waterproof connectors are available

USB Cables

- Connects the PC and the servo drive for ASDA-Soft operation
- Mini USB Type B communication port, compatible with USB 2.0

Regenerative Resistor

- Refer to Section 2.8 in the ASDA-B3 user manual for selection

Note: Under high-interference environment, installing a USB isolator is recommended (Delta's product model: UC-ADP01-A)



Servo System Combination Table

220 V

Built-in Motor						Drive	Power Cable		Power
Frame Size	Output (W)	Model Name	Rotational Inertia ($\times 10^{-4} \text{kg.m}^2$)	Rated / Max. Speed (rpm)	Rated / Max. Current (A)	Model Name	Standard	Torsion-Resistant	Standard
			Standard / With Brake						
40	100	ECM-B3L-C [2] 0401RB1	0.0299/0.0315	3,000/6,000	0.857/3.44	ASD-B3①-0121-②			
		ECM-B3L-C [2] 0401SB1							
60	200	ECM-B3M-C [2] 0602RB1	0.141/0.151	3,000/6,000	1.42/6.62	ASD-B3①-0221-②	ACS3-AFPWSRXX ACS3-ABPWSRXX ACS3-AFPWSR0C ACS3-ABPWSR0C	ACS3-AFPRSXX ACS3-ABPRSXX ACS3-AFPRS0C ACS3-ABPRS0C	ACS3-AFPW ACS3-ABPW ACS3-AFPW ACS3-ABPW
		ECM-B3M-C [2] 0602SB1							
	200	ECM-B3H- C [2] 0602RB1	0.265/0.28	3,000/6,700	1.48/5.98	ASD-B3①-0221-②			
		ECM-B3H- C [2] 0602SB1							
	400	ECM-B3M-C [2] 0604RB1	0.254/0.264	3,000/6,000	2.40/9.47	ASD-B3①-0421-②			
		ECM-B3M-C [2] 0604SB1							
	400	ECM-B3H- C [2] 0604RB1	0.523/0.538	3,000/6,700	2.15/8.37	ASD-B3①-0421-②			
		ECM-B3H- C [2] 0604SB1							
80	750	EECM-B3M-C [2] 0807RB1	1.07/1.13	3,000/6,000	4.27/15.8	ASD-B3①-0721-②			
		ECM-B3M-C [2] 0807SB1				ASD-B3①-1021-②			
	750	ECM-B3H- C [2] 0807RB1	1.55/1.62	3,000/6,700	4.13/16.1	ASD-B3①-0721-②			
		ECM-B3H- C [2] 0807SB1				ASD-B3①-1021-②			

Note:

- Cable model name: The "XX" stands for cable length. 03 = 3 m, 05 = 5 m, 10 = 10 m, 20 = 20 m.
- Servo motor model name: [2] = encoder type, [3] = type of shaft and oil seal, [4] = shaft diameter and connector type, [5] = special code.
- Servo drive model name: ① = product series, ② = model code.
- Cables are divided into direct (towards motor shaft) and reverse (towards encoder) exit direction. For details, please refer to the ordering information.

Connector & Cable						Connector Only (No Cable)		
Encoder Cable with Brake		Encoder Cable (Incremental Type)		Encoder Cable (Absolute Type)		Power Connector	Power Connector (with brake) / Brake Connector	Encoder Connector
Torsion-Resistant	Standard	Torsion-Resistant	Standard	Torsion-Resistant				
SSXX	ACS3-AFPRSSXX	ACS3-AFEASIXX	ACS3-AFERSIXX	ACS3-AFEASAXX	ACS3-AFERSAXX	ACS3-AFPWSS00	ACS3-AFPWSS00	ACS3-CNENC200 + ACS3-AFEASA00
SSXX	ACS3-ABPRSSXX	ACS3-ABEASIXX	ACS3-ABERSIXX	ACS3-ABEASAXX	ACS3-ABERSAXX	ACS3-ABPWSS00	ACS3-ABPWSS00	
SS0C	ACS3-AFPRSS0C	ACS3-AFEASI0C	ACS3-AFERSI0C	ACS3-AFEASA0C	ACS3-AFERSA0C	ACS3-ABPWSS00	ACS3-ABPWSS00	
SS0C	ACS3-ABPRSS0C	ACS3-ABEASI0C	ACS3-ABERSI0C	ACS3-ABEASA0C	ACS3-ABERSA0C			

Servo System Combination Table

220 V

Motor with Line (Frame Size 40 ~ 80)						Drive	Power Cable		
Frame Size	Output (W)	Model Name	Rotational Inertia ($\times 10^{-4} \text{kg.m}^2$)	Rated / Max. Speed (rpm)	Rated / Max. Current (A)	Model Name	Standard	Torsion-Resistant	Standard
			Standard / With Brake						
40	100	ECM-B3L-C [2] 0401RS1	0.0299/0.0315	3,000/6,000	0.857/3.44	ASD-B3①-0121-②			
		ECM-B3L-C [2] 0401SS1							
60	200	ECM-B3M-C [2] 0602RS1	0.141/0.151	3,000/6,000	1.42/6.62	ASD-B3①-0221-②	ACS3-CAP W11XX	ACS3-CAPF11XX	ACS3-CAP
		ECM-B3M-C [2] 0602SS1							
	200	ECM-B3H- C [2] 0602RS1	0.265/0.28	3,000/6,700	1.48/5.98	ASD-B3①-0221-②			
		ECM-B3H- C [2] 0602SS1							
	400	ECM-B3M-C [2] 0604RS1	0.254/0.264	3,000/6,000	2.40/9.47	ASD-B3①-0421-②			
		ECM-B3M-C [2] 0604SS1							
	400	ECM-B3H- C [2] 0604RS1	0.523/0.538	3,000/6,700	2.15/8.37	ASD-B3①-0421-②			
		ECM-B3H- C [2] 0604SS1							
80	750	ECM-B3M-C [2] 0807RS1	1.07/1.13	3,000/6,000	4.27/15.8	ASD-B3①-0721-②			
		ECM-B3M-C [2] 0807SS1			4.27/15.8				
	750	ECM-B3H- C [2] 20807RS1	1.55/1.62	3,000/6,700	4.13/16.1	ASD-B3①-0721-②			
		ECM-B3H- C [2] 20807SS1				ASD-B3①-1021-②			
	750	ECM-B3G- C [2] 20807RS1	2.91/2.96	3,000/6,000	4.27/15.8	ASD-B3①-0721-②			
		ECM-B3G- C [2] 20807SS1				ASD-B3①-1021-②			
	1,000	ECM-B3M-C [2] 0810RS1	1.37/1.4	3,000/6,000	5.00/18.2	ASD-B3①-1021-②			
		ECM-B3M-C [2] 0810SS1							

Note:

1. Cable model name: The "XX" stands for cable length. 03 = 3 m, 05 = 5 m, 10 = 10 m, 20 = 20 m.

2. Servo motor model name: [2] = encoder type, [3] = type of shaft and oil seal, [4] = shaft diameter and connector type, [5] = special code.

3. Servo drive model name: ① = product series, ② = model code.

Connector & Cable						Connector Only (No Cable)		
Power Cable with Brake		Encoder Cable (Incremental Type)		Encoder Cable (Absolute Type)		Power Connector	Power Connector (with brake) / Brake Connector	Encoder Connector
Standard	Torsion-Resistant	Standard	Torsion-Resistant	Standard	Torsion-Resistant			
ACS3-CAPF21XX	ACS3-CAPF21XX	ACS3-CAEN01XX	ACS3-CAEF01XX	ACS3-CAEA01XX	ACS3-CAEB01XX	ACS3-CAPW1000	ACS3-CAPW2000	ACS3-CNENC200 + ACS3-CAEN0000

Servo System Combination Table

220 V

Frame Size 100 ~ 220						Drive	Power Cable		Power
Frame Size	Output (W)	Model Name	Rotational Inertia ($\times 10^{-4} \text{kg.m}^2$) Standard/ With Brake	Rated / Max. Speed (rpm)	Rated / Max. Current (A)		Model Name	Standard	
100	1,000	ECM-B3M-C ② 1010RS1	2.78/3.06	3,000/6,000	6.05/18.4	ASD-B3①-1021-②	ACS3-CAP WA2XX ACS3-CRP WA2XX	ACS3-CAPFA2XX ACS3-CRPFA2XX	ACS3-CABR ACS3-CRBR
		ECM-B3M-C ② 1010SS1							
	1,500	ECM-B3M-C ② 1015RS1	3.69/3.97	3,000/6,000	7.48/22.8	ASD-B3①-1521-②			
		ECM-B3M-C ② 1015SS1							
	2,000	ECM-B3M-C ② 1020RS1	4.68/4.95	3,000/6,000	9.96/30.7	ASD-B3①-2023-②			
		ECM-B3M-C ② 1020SS1							
130	850	ECM-B3H-L ② 1308RS1	12.44/12.62	1,500/4,000	6.65/20.0	ASD-B3①-1021-②			
		ECM-B3H-L ② 1308SS1							
	1,000	ECM-B3M-E ② 1310RS1	7.79/7.94	2,000/3,000	5.96/19.9	ASD-B3①-1021-②			
		ECM-B3M-E ② 1310SS1							
	1,300	ECM-B3H-L ② 1313RS1	18/18.14	1,500/4,000	7.7/23.9	ASD-B3①-1521-②			
		ECM-B3H-L ② 1313SS1							
	1,500	ECM-B3M-E ② 1315RS1	11.22/11.37	2,000/3,000	8.17/26.82	ASD-B3①-1521-② ASD-B3①-2023-②			
		ECM-B3M-E ② 1315SS1							
	1,800	ECM-B3H-L ② 1318RS1	22.6/22.8	1,500/4,000	11.5/36.1	ASD-B3①-2023-②			
		ECM-B3H-L ② 1318SS1							
	2,000	ECM-B3M-E ② 1320RS1	14.65/14.8	2,000/3,000	10.59/34.20	ASD-B3①-2023-②			
		ECM-B3M-E ② 1320SS1							
180	2,000	ECM-B3M-E ② 1820RS1	29.11/30.38	2,000/3,000	11.43/36.21	ASD-B3①-2023-②	ACS3-CAP WC4XX ACS3-CRP WC4XX	ACS3-CAPFC4XX ACS3-CRPFC4XX	
		ECM-B3M-E ② 1820SS1							
	3,000	ECM-B3M-F ② 1830RS1	53.63/54.9	1,500/3,000	18.21/58.9	ASD-B3①-3023-②			
		ECM-B3M-F ② 1830SS1							

Note:

1. Cable model name: The "XX" stands for cable length. 03 = 3 m, 05 = 5 m, 10 = 10 m, 20 = 20 m.
2. Servo motor model name: ② = encoder type.
3. Servo drive model name: ① = product series, ② = model code.
4. Cables are divided into straight and angular connectors. For details, please refer to the ordering information.

Connector & Cable						Connector Only (No Cable)		
Encoder Cable with Brake		Encoder Cable (Incremental Type)		Encoder Cable (Absolute Type)		Power Connector	Power Connector (with brake) / Brake Connector	Encoder Connector
Standard	Torsion-Resistant	Standard	Torsion-Resistant	Standard	Torsion-Resistant			
ACS3-CABFA1XX	ACS3-CRBA1XX	ACS3-CAENA1XX	ACS3-CRENA1XX	ACS3-CAEAA1XX	ACS3-CREAA1XX	ACS3-CAPWA000 ACS3-CRPWA000	ACS3-CABRA000 ACS3-CRBRA000	ACS3-CNENC200 + ACS3-CAENA000 ACS3-CRENA000
						ACS3-CAPWC000 ACS3-CRPWC000		

Servo System Combination Table

220 V

A3L Motor						Drive	Power Cable		
Frame Size	Output (W)	Model Name	Rotational Inertia ($\times 10^{-4} \text{kg.m}^2$) Standard/ With Brake	Rated / Max. Speed (rpm)	Rated / Max. Current (A)		Model Name	Standard	Torsion-Resistant
40	100	ECM-A3L-C [2] 0401RS1	0.04/0.0426	3,000/6,000	0.9/3.88	ASD-B3①-0121-②	ACS3-CAPW11XX	ACS3-CAPF11XX	ACS3-CAPW
		ECM-A3L-C [2] 0401SS1							
60	200	ECM-A3L-C [2] 0602RS1	0.09/0.12	3,000/6,000	1.45/6.2	ASD-B3①-0221-②			
		ECM-A3L-C [2] 0602SS1							
	400	ECM-A3L-C [2] 0604RS1	0.15/0.18	3,000/6,000	2.65/10.1	ASD-B3①-0421-②			
		ECM-A3L-C [2] 0604SS1							
80	400	ECM-A3L-C [2] 0804RS1	0.352/0.408	3,000/6,000	2.6/10.6	ASD-B3①-0421-②			
		ECM-A3L-C [2] 0804SS1							
	750	ECM-A3L-C [2] 0807RS1	0.559/0.614	3,000/6,000	5.1/20.6	ASD-B3①-0721-② ASD-B3①-1021-②			
		ECM-A3L-C [2] 0807SS1							

Note:

1. Cable model name: The "XX" stands for cable length. 03 = 3 m, 05 = 5 m, 10 = 10 m, 20 = 20 m.
2. Servo motor model name: [2] = encoder type, [3] = type of shaft and oil seal, [4] = shaft diameter and connector type, [5] = special code.
3. Servo drive model name: ① = product series, ② = model code.

Connector & Cable						Connector Only (No Cable)		
Encoder Cable with Brake		Encoder Cable (Incremental Type)		Encoder Cable (Absolute Type)		Power Connector	Power Connector (with brake) / Brake Connector	Encoder Connector
Torsion-Resistant	Standard	Torsion-Resistant	Standard	Torsion-Resistant				
ACS3-CAPF21XX	ACS3-CAEN01XX	ACS3-CAEF01XX	ACS3-CAEA01XX	ACS3-CAEB01XX	ACS3-CAPW1000	ACS3-CAPW2000	ACS3-CNENC200 + ACS3-CAEN0000	

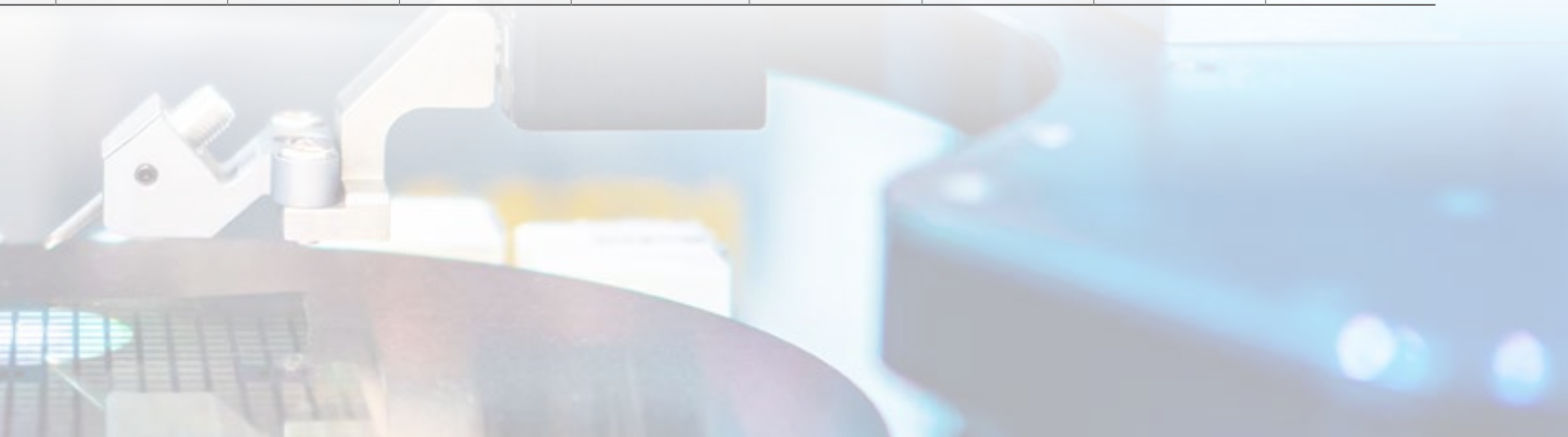

Servo System Combination Table

400 V

Frame Size 40 ~ 220						Drive	Power Cable		
Frame Size	Output (W)	Model Name	Rotational Inertia (x10 ⁻⁴ kg.m ²) Standard/ With Brake	Rated / Max. Speed (rpm)	Rated / Max. Current (A)		Model Name	Standard	Torsion-Resistant
60	400	ECM-B3M-J [2] 0604RS1	0.254/0.264	3,000/6,000	1.35/5.2	ASD-B3①-1043-②	ACS3-CAPW31XX	ACS3-CAPF31XX	
		ECM-B3M-J [2] 0604SS1							
80	750	ECM-B3M-J [2] 0807RS1	1.07/1.13	3,000/6,000	2.15/7.9	ASD-B3①-1043-②			
		ECM-B3M-J [2] 0807SS1				ASD-B3①-1543-②			
100	1,000	ECM-B3M-J [2] 1010RS1	2.78/3.06	3,000/6,000	3.03/9.21	ASD-B3①-1043-②	ACS3-CAPWA2XX ACS3-CRPWA2XX	ACS3-CAPFA2XX ACS3-CRPFA2XX	ACS3-CAB ACS3-CRB
		ECM-B3M-J [2] 1010SS1				ASD-B3①-1543-②			
	1,500	ECM-B3M-J [2] 1015RS1	3.69/3.97	3,000/6,000	3.73/11.4	ASD-B3①-1543-②			
		ECM-B3M-J [2] 1015SS1				ASD-B3①-2043-②			
	2,000	ECM-B3M-J [2] 1020RS1	4.68/4.95	3,000/6,000	5 / 15.3	ASD-B3①-2043-②			
		ECM-B3M-J [2] 1020SS1							
130	850	ECM-B3H-L [2] 1308RS1	12.44/12.62	1,500/4,000	3.35/10	ASD-B3①-1043-②	ACS3-CAPWA2XX ACS3-CRPWA2XX	ACS3-CAPFA2XX ACS3-CRPFA2XX	ACS3-CAB ACS3-CRB
		ECM-B3H-L [2] 1308SS1				ASD-B3①-1543-②			
	1,000	ECM-B3M-K [2] 1310RS1	7.79/7.94	2,000/3,000	3/9.95	ASD-B3①-1043-②			
		ECM-B3M-K [2] 1310SS1				ASD-B3①-1543-②			
	1,300	ECM-B3H-L [2] 1313RS1	18/18.14	1,500/4,000	3.85/12	ASD-B3①-1543-②			
		ECM-B3H-L [2] 1313SS1				ASD-B3①-2043-②			
	1,500	ECM-B3M-K [2] 1315RS1	11.22/11.37	2,000/3,000	4.09/13.37	ASD-B3①-1543-②			
		ECM-B3M-K [2] 1315SS1				ASD-B3①-2043-②			
	1,800	ECM-B3H-L [2] 1318RS1	22.6/22.8	1,500/4,000	5.75/18.1	ASD-B3①-2043-②			
		ECM-B3H-L [2] 1318SS1							
	2,000	ECM-B3M-K [2] 1320RS1	14.65/14.8	2,000/3,000	5.3/17.1	ASD-B3①-2043-②			
		ECM-B3M-K [2] 1320SS1							
180	2,000	ECM-B3M-K [2] 1820RS1	29.11/30.38	2,000/3,000	5.7/18.1	ASD-B3①-2043-②	ACS3-CAPWC3XX ACS3-CRPWC3XX	ACS3-CAPFC3XX ACS3-CRPFC3XX	
		ECM-B3M-K [2] 1820SS1							
	3,000	ECM-B3M-L [2] 1830RS1	53.63/54.9	1,500/3,000	9.1/29.45	ASD-B3①-3043-②			
		ECM-B3M-L [2] 1830SS1				ASD-B3①-4543-②			
	4,500	ECM-B3M-L [2] 1845RS1	67.73/69.15	1,500/4,000	13.3/35.35	ASD-B3①-4543-②	ACS3-CAPWC4XX ACS3-CRPWC4XX	ACS3-CAPFC4XX ACS3-CRPFC4XX	
		ECM-B3M-L [2] 1845SS1							
	5,500	ECM-B3M-L [2] 1855RS31	98.88/100.1	1,500/4,000	15.3/49.29	ASD-B3①-5543-②	ACS3-CAPWE6XX ACS3-CRPWE6XX	ACS3-CAPFE6XX ACS3-CRPFE6XX	
		ECM-B3M-L [2] 1855SS31							
	7,500	ECM-B3M-L [2] 1875RS31	134.95/136.24	1,500/4,000	22.1/56.68	ASD-B3①-7543-②			
		ECM-B3M-L [2] 1875SS31							

Note:

1. Cable model name: The "XX" stands for cable length. 03 = 3 m, 05 = 5 m, 10 = 10 m, 20 = 20 m.

2. Servo motor model name: [2] = encoder type.

3. Cables are divided into standard, high flex, straight, and angular connectors.

For details, please refer to the ordering information .

Connector & Cable						Connector Only (No Cable)		
Encoder Cable with Brake		Encoder Cable (Incremental Type)		Encoder Cable (Absolute Type)		Power Connector	Power Connector (with brake) / Brake Connector	Encoder Connector
Standard	Torsion-Resistant	Standard	Torsion-Resistant	Standard	Torsion-Resistant			
		ACS3-CAEN01XX	ACS3-CAEF01XX	ACS3-CAEA01XX	ACS3-CAEB01XX	ACS3-CAPW1000	ACS3-CAPW2000	
ACS3-CABFA1XX ACS3-CRBF1XX	ACS3-CABFA1XX ACS3-CRBF1XX	ACS3-CAENA1XX ACS3-CRENA1XX	ACS3-CAEFA1XX ACS3-CREFA1XX	ACS3-CAEA1XX ACS3-CREA1XX	ACS3-CAEBA1XX ACS3-CREBA1XX	ACS3-CAPWA000 ACS3-CRPWA000	ACS3-CABRA000 ACS3-CRBRA000	ACS3-CNENC200 + ACS3-CAENA000 ACS3-CRENA000
						ACS3-CAPWC000 ACS3-CRPWC000		
						ACS3-CAPWC000 ACS3-CRPWC000		
						ACS3-CAPWE000 ACS3-CRPWE000		

Servo Drive Model Information

ASD-B3 Series Servo Drive

ASD - B3 - 04 21 - L

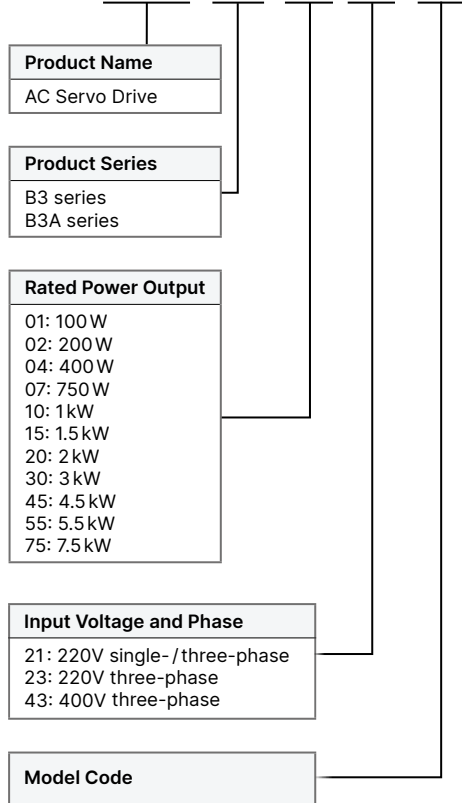

ASD-B3

Code	PT Mode Pulse Input	PR Mode	RS-485	Analog Voltage Control	CANopen	DMCNET	EtherCAT	STO
L	✓	✓	✓	✓	-	-	-	-
M	-	✓	-	✓	✓	-	-	-
F	-	✓	-	✓	-	✓	-	-
E	-	✓	-	✓	-	-	✓	-

ASD-B3A*1

Code	PT Mode Pulse Input	PR Mode	RS-485	Analog Voltage Control	CANopen	DMCNET	EtherCAT	PROFINET	STO*2
L	✓	✓	✓	✓	-	-	-	-	✓
M	✓	✓	✓	✓	✓	-	-	-	✓
F	✓	✓	-	✓	-	✓	-	-	✓
E	✓	✓	-	✓	-	-	✓	-	✓
P	-	✓	-	-	-	-	-	✓	✓





*1. B3A supports dynamic brake function

*2. B3A 200V supports STO (SIL2); B3A 400V STO (SIL3) certification in process

Note: The model information is for reference only. Not all kinds of permutations are available. Please contact the distributor near your region or Delta for the details.



Servo Drive Specifications



ASD-B3			100 W 01	200 W 02	400 W 04	750 W 07	1kW 10	1.5kW 15	2kW 20	3kW 30	
Power Supply	Phase / Voltage		Single-phase / Three-phase 220V _{AC}						Three-phase 220V _{AC}		
	Permissible Voltage		Single-phase / Three-phase 200 - 230V _{AC} , -15% to 10%						Three-phase 200 - 230V _{AC} , -15% to 10%		
	Input Current (3PH) (Unit: Arms)		0.88	1.29	2.04	3.52	5.72	6.33	7.6	10.3	
	Input Current (1PH) (Unit: Arms)		1.47	2.35	3.74	6.47	10.4	11.7	-	-	
	Continuous Output Current (Unit: Arms)		0.9	1.55	2.65	5.1	7.3	8.3	13.4	19.4	
	Max. Instantaneous Output Current (Unit: Arms)		3.88	7.07	10.6	14.14	21.21	24.3	38.3	53.03	
	Final Power Dissipation (W)		19.8	24.1	35.0	60.0	79.1	99.0	123.2	174.0	
Regenerative Resistor	Built-in Regenerative Resistor	Resistance (Ohm)	-	-	100	100	100	100	20	20	
		Capacity (Watt)	-	-	40	40	40	40	80	80	
	External Minimum Allowable Resistance Value(Ohm)		60	60	60	60	30	30	15	15	
Cooling Method			Natural cooling				Fan cooling				
Drive Resolution			24-bit (16,777,216 pls/rev)								
Main Circuit Control			SVPWM control								
Tuning Mode			Auto / Manual								
Position Control Mode	Pulse Type (only for pulse control mode)		Pulse + Direction; A phase + B phase; CCW pulse + CW pulse								
	Max. Output Pulse Frequency (only for pulse control mode)		Pulse + direction: 4 Mpps; CCW pulse + CW pulse: 4 Mpps; A phase + B phase: single-phase 2 Mpps; Open collector: 200 Kpps								
	Command Source		External pulse (only for pulse control mode) / Internal register (PR mode)								
	Smoothing Method		Low-pass, S-curve, and moving filters								
	E-Gear Ratio		E-Gear ratio: N / M times, limited to (1 / 4 < N / M < 262144) N: 1 - 536870911/M: 1 - 2147483647								
	Torque Limit		Parameter settings								
	Feed Forward Compensation		Parameter settings								
Speed Control Mode	Analog Command Input	Voltage Range	0 to ±10 V _{DC}								
		Resolution	12-bit								
		Input Impedance	1MΩ								
		Time Constant	25μs								
	Speed Control Range ^{*1}		1 : 6000								
	Command Source		External analog command / Internal register								
	Smoothing Method		Low-pass and S-curve filters								
	Torque Limit		Parameter settings or analog input								
	Bandwidth		Maximum 3.1kHz								
	Speed Calibration Ratio ^{*2}		±0.01% at 0% to 100% load fluctuation ±0.01% at ±10% power fluctuation ±0.01% at 0°C to 50°C ambient temperature fluctuation								
Torque Control Mode	Analog Command Input	Voltage Range	0 to ±10 V _{DC}								
		Input Impedance	1 MΩ								
		Time Constant	25μs								
	Command Source		External analog command / Internal register								
	Smoothing Method		Low-pass filter								
Speed Limit		Parameter settings or analog input									
Analog Monitor Output			Monitoring signal can be set with parameters (voltage output range: ±8V); resolution: 10-bit								
Digital Input / Output	Input		L: 9 Inputs; M, F, E: 4 Inputs; P: 6 Inputs								
	Output		L: 6 Outputs; M, F, E: 2 Outputs; P: 3 Outputs								
Protection Function			Overcurrent, Overvoltage, Undervoltage, Overheat, Regeneration error, Overload, Excessive speed deviation, Excessive position deviation, Encoder error, Adjustment error, Emergency stop, Forward / reverse limit error, Serial communication error, RST leak phase, Serial communication timeout, Short-circuit protection for terminals U, V, W								
Communication Interface			USB / RS-485 / CANopen / DMCNET / EtherCAT								
Environment	Installation Site		Indoors (avoid direct sunlight), no corrosive vapor (avoid fumes, flammable gases, and dust)								
	Altitude		Altitude 2000 m or lower above sea level								
	Atmospheric Pressure		86 kPa - 106 kPa								
	Operating Temperature		0°C to 55°C (If operating temperature is above 45°C, forced cooling is required)								
	Storage Temperature		-20°C to 65°C								
	Humidity		0 to 90% RH (non-condensing)								
	Vibration		10 Hz ~ 57 Hz : 0.075 mm amplitude · 58 Hz ~ 150 Hz : 1G								
	IP Rating		IP20								
	Power System		TN system ^{*3,4}								
Certifications			IEC/EN/UL 61800-5-1    								

Notes:

- *1. Within the rated load, the speed ratio is: the minimum speed (smooth operation) / rated speed.
- *2. Within the rated speed, the speed calibration ratio is: (rotational speed with no load - rotational speed with full load) / rated speed.
- *3. TN system: the neutral point of the power system connects directly to the ground.
The exposed metal components connect to the ground through the protective ground conductor.
- *4. Use a single-phase three-wire power system for the single-phase power model.
- *5. ASDA-B3A complies with the TUV Functional Safety certification.

Servo Drive Specifications

400 V

ASD-B3			1kW	1.5kW	2kW	3kW	4.5kW	5.5kW	7.5kW
			10	15	20	30	45	55	75
Main Circuit Power Supply	Phase / Voltage		Three-phase 400 V _{AC}						
	Permissible Voltage		Three-phase 380 - 440 V _{AC} , -10% - +10%						
	Input Current (3PH) (Unit: Arms)		2.91	3.52	5.06	6.14	12	14.5	20
	Inrush Current (Unit: Arms)		5.66	5.66	5.66	5.66	37.72	37.72	37.72
Control Power Supply	Phase / Voltage		Single-phase 400V _{AC}						
	Permissible Voltage		Single-phase 380 - 400 V _{AC} , -10% - +10%						
	Input Current (3PH) (Unit: Arms)		0.1	0.1	0.1	0.1	0.13	0.13	0.13
	Input Current (1PH) (Unit: Arms)		37.72	37.72	37.72	37.72	37.72	37.72	37.72
Continuous Output Current (Unit: Arms)			3.37	4.09	5.96	9.11	13.3	15.34	22.11
Max. Instantaneous Output Current (Unit: Arms)			7.07	10.6	18.98	27.33	35.35	49.29	53.03
Power Loss (W)			43.6	59.0	105.8	157.0	185.0	204.0	349.0
Regenerative Resistor	Built-in Regenerative Resistor	Resistance (Ohm)	100	100	50	50	35	35	35
		Capacity (Watt)	80	80	80	80	100	100	100
	External Minimum Allowable Resistance Value (Ohm)		80	60	45	40	35	25	25
Cooling Method			Fan cooling						
Drive Resolution			24-bit (16777216 p/rev)						
Main Circuit Control			SVPW Mcontrol						
Tuning Mode			Auto / Manual						
Position Control Mode	Pulse Type (only for pulse control mode)		Pulse + Direction; A phase + B phase; CCW pulse + CW pulse						
	Max. Output Pulse Frequency (only for pulse control mode)		Pulse + direction: 4 Mpps; CCW pulse + CW pulse: 4 Mpps; A phase + B phase: single-phase 2 Mpps; Open collector: 200 Kpps						
	Command Source		External pulse (only for pulse control mode) / Internal register (PR mode)						
	Smoothing Method		Low-pass, S-curve, and moving filters						
	E-Gear Ratio		E-Gear ratio: N / M times, limited to (1/4 < N/M < 262144) N: 1-536870911/M: 1-2147483647						
	Torque Limit		Parameter settings						
	Feed Forward Compensation		Parameter settings						
Speed Control Mode	Analog Command Input	Voltage Range	0 - ± 10 V _{DC}						
		Resolution	12-bit						
		Input Impedance	1MΩ						
		Time Constant	25μs						
	Speed Control Range ¹		1:6000						
	Command Source		External analog command / Internal register						
	Smoothing Method		Low-pass and S-curve filters						
	Torque Limit		Parameter settings or analog input						
Bandwidth		Maximum 3.1kHz							
Speed Calibration Ratio ²		± 0.01% at 0% to 100% load fluctuation ± 0.01% at ± 10% power fluctuation ± 0.01% at 0°C to 50°C ambient temperature fluctuation							
Torque Control Mode	Analog Command Input	Voltage Range	0 - ± 10 V _{DC}						
		Input Impedance	1MΩ						
		Time Constant	25μs						
	Command Source		External analog command / Internal register						
Smoothing Method		Low-pass filter							
Speed Limit		Parameter settings or analog input							
Analog Monitor Output			Monitoring signal can be set with parameters (voltage output range: ± 8V); resolution: 10-bit						
Digital Input			L: 9 Inputs; M, F, E: 4 Inputs						
Digital Output			L: 6 Outputs; M, F, E: 2 Outputs						
Protection Function			Overcurrent, Overvoltage, Undervoltage, Overheat, Regeneration error, Overload, Excessive speed deviation, Excessive position deviation, Encoder error, Adjustment error, Emergency stop, Forward / reverse limit error, Serial communication error, RST leak phase, Serial communication timeout, Short-circuit protection for terminals U, V, W						
Communication Interface			RS-485 / USB / CANopen / DMCNET / EtherCAT						
Environment	Installation Site		Indoors (avoid direct sunlight), no corrosive vapor (avoid fumes, flammable gases, and dust)						
	Altitude		Altitude 2000 m or lower above sea level						
	Atmospheric Pressure		86kPa - 106kPa						
	Operating Temperature		0°C - 55°C (If operating temperature is above 45°C, forced cooling is required)						
	Storage Temperature		-20°C - 65°C						
	Humidity		0 - 90% RH (non-condensing)						
	Vibration		0Hz - 57Hz: 0.075 mm amplitude, 58Hz - 150Hz: 1G						
	IP Rating		IP20						
	Power System		TN system ^{3*4}						
	Certifications		IEC/EN 61800-5-1  						

Notes:

- *1. Within the rated load, the speed ratio is: the minimum speed (smooth operation) / rated speed
- *2. Within the rated speed, the speed calibration ratio is: (rotational speed with no load - rotational speed with full load) / rated speed
- *3. TN system: the neutral point of the power system connects directly to the ground. The exposed metal components connect to the ground through the protective ground conductor
- *4. Use a single-phase three-wire power system for the single-phase power model
- *5. B3A TUV Functional Safety certification in process

Dimensions - 220 V

100 W / 200 W / 400 W

Weight	Unit
0.9 kg	mm (inch)

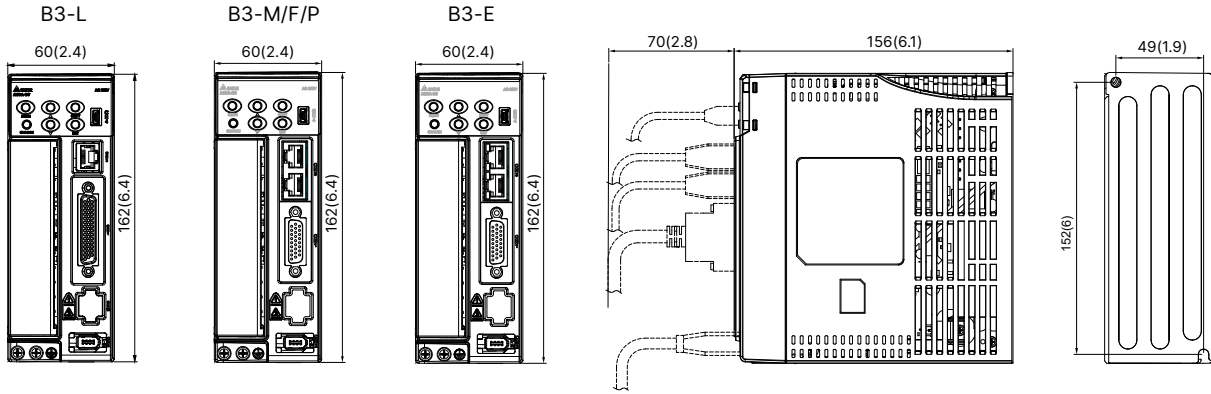

750 W

Weight	Unit
1.2 kg	mm (inch)

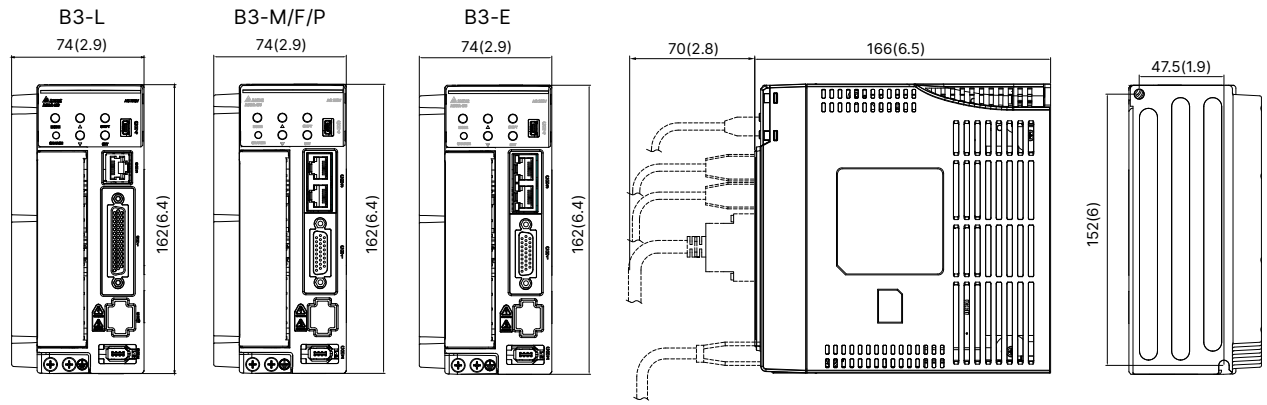

1kW/1.5 kW

Weight	Unit
1.8 kg	mm (inch)

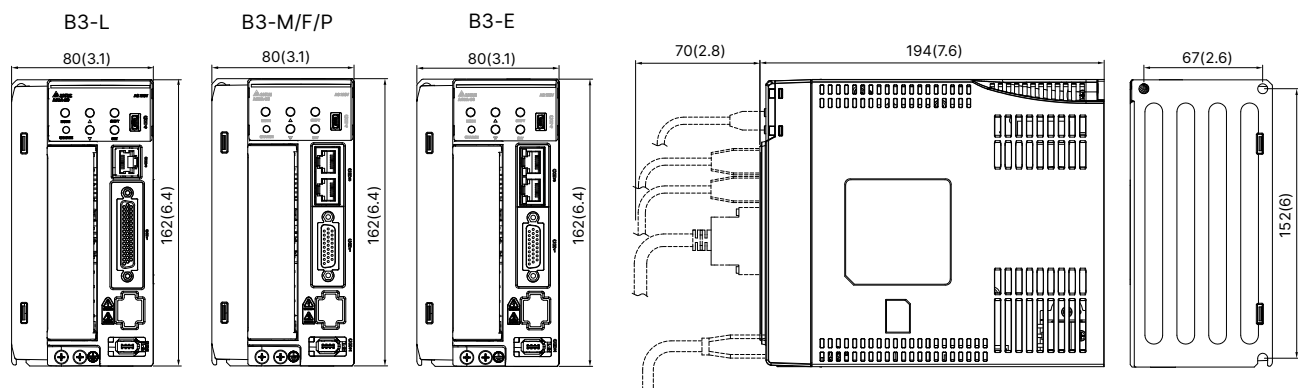

Servo Drive Specifications

Dimensions - 220 V

2 kW/3 kW

Weight	Unit
2.8 kg	mm (inch)

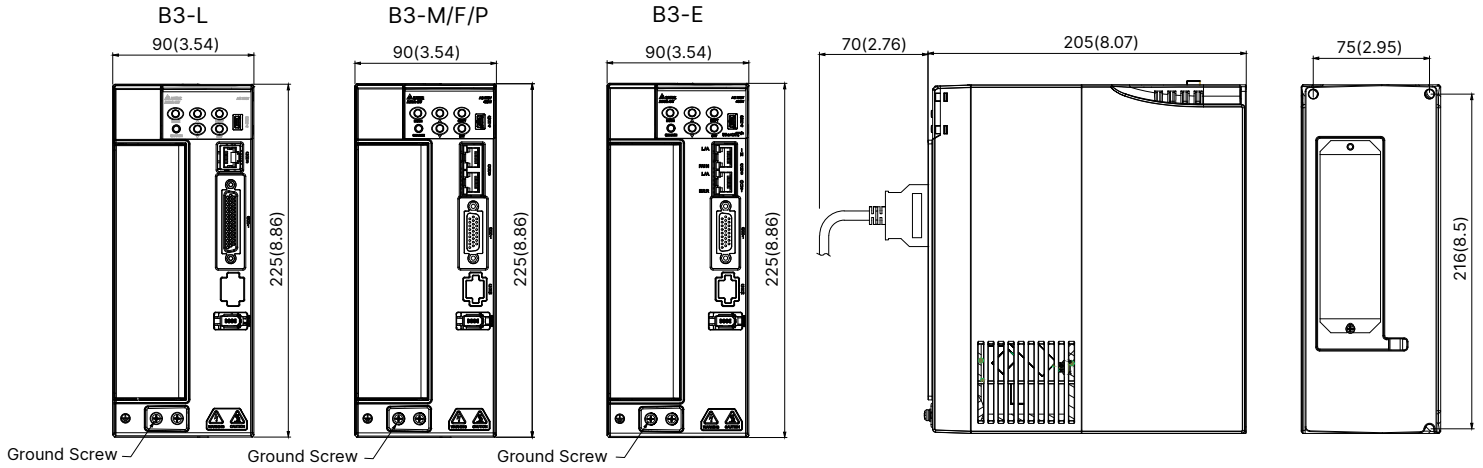

Dimensions - 400 V

2 kW/3 kW

	Weight	Unit
1 kW/1.5 kW	1.6 kg	mm (inch)
2 kW/3 kW	1.7 kg	mm (inch)

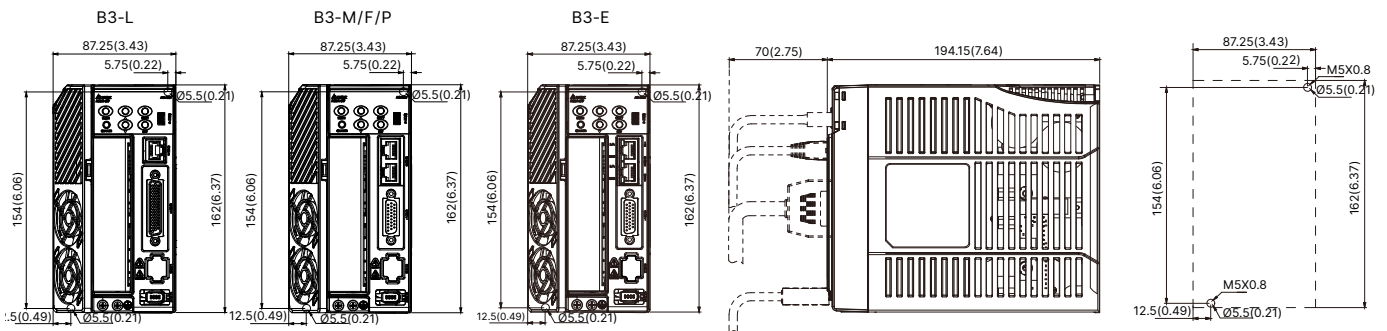

Dimensions - 400 V

4.5 kW / 5.5 kW / 7.5 kW

Weight	Unit
2.9 kg	mm (inch)

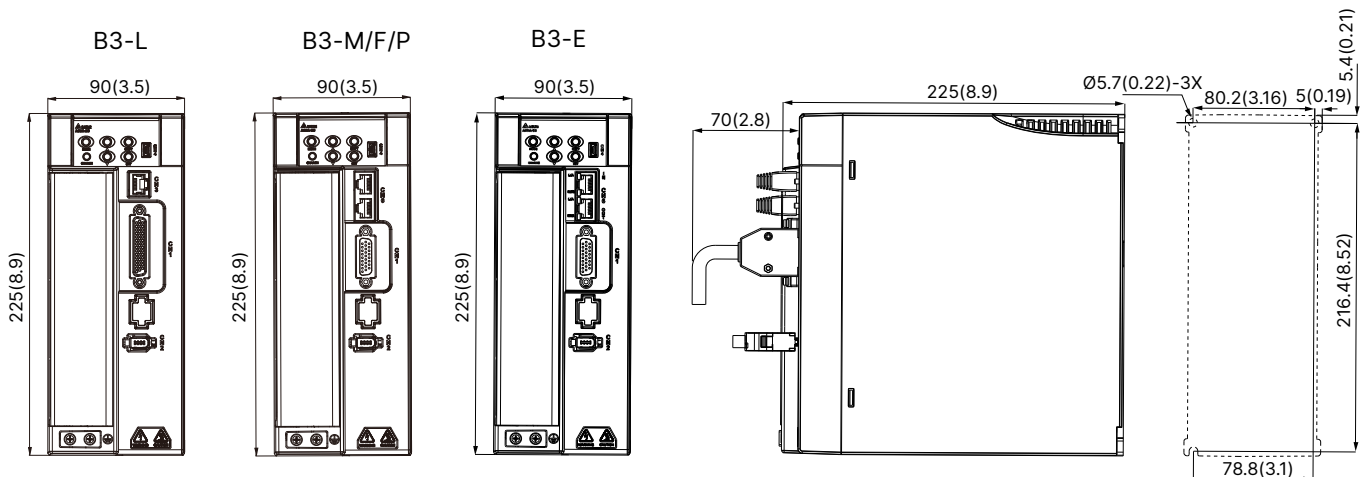

Servo Motor Model Information

ECM-B3 Series Servo Motor

ECM - B3 M - C A 06 04 R B 1

Product Name
ECM:
Electronic
Commutation
Motor

Series
B3 series

Inertia
H: High inertia
M: Medium inertia
L: Low inertia
G: Ultra-High inertia

Rated Voltage and Speed
C: 220V / 3,000 rpm
E: 220V / 2,000 rpm
F: 220V / 1,500 rpm
J: 400V / 3,000 rpm
K: 400V / 2,000 rpm
L: 400V / 1,500 rpm

Encoder Type
A: 24-bit absolute optical encoder
Resolution of single turn: 24-bit
Resolution of multiple turns: 16-bit
B: 24-bit absolute magnetic/optical battery-less
encoder
2: 24-bit incremental optical encoder
P: 17-bit absolute magnetic optical encoder
Resolution of single turn: 17-bit
Resolution of multiple turns: 16-bit
M: 17-bit incremental magnetic optical encoder

Motor Frame Size
04 : 40mm 06 : 60mm
08 : 80mm 10 : 100mm
13 : 130mm 18 : 180mm
22 : 220mm

Rated Power Output
01 : 100W 02 : 200W
04 : 400W 07 : 750W
08 : 850W 10 : 1kW
13 : 1.3kW 15 : 1.5kW
18 : 1.8kW 20 : 2kW
30 : 3kW 45 : 4.5kW
55 : 5.5kW 75 : 7.5kW
1B : 11kW 1F : 15kW

Type of Shaft and Oil Seal	w/o Brake with Oil Seal	with Brake with Oil Seal
Keyway (with fixed screw holes)	R	S

Shaft Diameter	40/60/80	100/130/180/220
B	IP67 Built-in connector. Standard shaft diameter	
S	Standard connector with wire + standard shaft diameter	Mil-spec connector + standard shaft diameter
7	Standard connector with wire + standard shaft diameter* * For F80 400W model	
3		Mil-spec connector + special shaft diameter (42 mm)*

*Shafts of special diameter are used for 400 W motors with the frame size of 80 mm

Special Code
1: Standard products

Note: The model information is for reference only. Not all kinds of model permutations are available. Please contact the distributor near your region or Delta for the details.

ECM-A3 Series Servo Motor

ECM - A3 H - C Y 06 04 R S 1

Product Name
ECM :
Electronic
Commutation
Motor

Series
A3 series

Inertia
H: High inertia
L: Low inertia

Rated Voltage and Speed
C: 220V / 3,000 rpm

Encoder Type
Y: 24-bit absolute optical encoder
Resolution of single turn: 24-bit
Resolution of multiple turns^{*1}:
1: 24-bit incremental optical encoder^{*2}
A: 24-bit absolute magnetic optical encoder
Resolution of single turn: 24-bit
Resolution of multiple turns^{*1}: 16-bit
2: 24-bit incremental magnetic optical encoder^{*2}

*1. Number of turns
*2. Can be used as a single-turn absolute encoder

Motor Frame Size
04 : 40mm 06 : 60mm
08 : 80mm

Rated Power Output
0F : 50W 01 : 100W
02 : 200W 04 : 400W
07 : 750W

Type of Shaft and Oil Seal	w/o Brake w/o Oil Seal	with Brake w/o Oil Seal	w/o Brake with Oil Seal	with Brake with Oil Seal
Round Shaft (with fixed screw)	-	-	C	D
Keyway (with fixed screw holes)	P*	Q*	R	S

*Not standing models

Shaft Diameter
S: Standard connector and standard shaft diameter
7: Standard connector and special shaft diameter (14 mm)*
J: IP67 waterproof connector and standard shaft diameter
K: IP67 waterproof connector and special shaft diameter (14 mm)*

*Shafts of special diameter are used for 400 W motors with the frame size of 80 mm

Special Code
1: Standard products
Z: Refer to the note for dimensions on page 49

ECM-B3 Series Servo Motor Specifications

Electrical Specifications - 220 V

	ECM-B3H-C [2] 0602	ECM-B3H-C [2] 0604	ECM-B3H-C [2] 0807
Rated Power (kW)	0.2	0.4	0.75
Rated Torque (N-m) ^{*2}	0.64	1.27	2.4
Maximum Torque (N-m)	2.43	4.83	9.12
Rated Speed (rpm)	3,000		
Maximum Speed (rpm)	6,700		
Rated Current (Arms)	1.48	2.15	4.13
Max. Instantaneous Current (Arms)	5.98	8.37	16.1
Rated Power Rate (kW/s)	15.5	30.8	37.2
Rated Power Rate (kW/s) with brake	14.6	30.0	35.6
Rotor Inertia ($\times 10^{-4}$ kg.m ²)	0.265	0.523	1.55
Rotor Inertia ($\times 10^{-4}$ kg.m ²) with brake	0.28	0.538	1.62
Mechanical Time Constant (ms)	1.73	1.23	0.781
Mechanical Time Constant (ms) with brake	1.82	1.27	0.816
Torque Constant -KT (N-m/A)	0.432	0.591	0.581
Voltage Constant -KE (mV/(rpm))	15.5	21.4	20.57
Armature Resistance (Ohm)	4.17	2.85	0.575
Armature Inductance (mH)	5.87	4.50	1.00
Electrical Time Constant (ms)	1.41	1.58	1.74
Weight – without brake (kg)	0.68	1.05	2.15
Weight – with brake (kg)	1.23	1.6	2.95
Max. Radial Loading (N) ^{*5}	245	245	392
Max. Axial Loading (N) ^{*5}	74	74	147
Brake Working Voltage	24 V _{DC} \pm 10%		
Brake Power Consumption (at 20°C)[W]	7.6	7.6	10
Brake Holding Torque [Nt-m (min)] ^{*3}	1.3	1.3	3.8
Brake Release Time [ms (Max)]	20	20	40
Brake Pull-In Time [ms (Max)]	50	60	80
Derating (%) (with oil seal)	10	5	5
Torque Feature (T-N Curve)			
Insulation Class	Class A (UL), Class B (CE)		
Insulation Resistance	> 100 M Ω , DC 500V		
Insulation Strength	1.8 kVac, 1 sec		
Vibration Level (μ m)	V15		
Operating Temperature	-20°C ~ 60°C*4		
Storage Temperature	-20°C ~ 80°C		
Storage & Operation Humidity	20 ~ 90%RH (non-condensing)		
Vibration Capacity	2.5 G		
IP Rating	IP67 (when using waterproof connections and when an oil seal is fitted to the rotating shaft (for an oil seal model))		
Certifications			

Notes:

- In the servo motor model name, [1] represents the motor inertia and [2] represents the encoder type.
- The rated torque is the continuous permissible torque between 0 to 40°C operating temperature which is suitable for the servo motor mounted with the following heat sink dimensions.
F40, F60, F80: 250 mm x 250 mm x 6 mm
Material: aluminum
- The built-in servo motor brake is only for keeping the object in a stopped state.
Do not use it for deceleration or as a dynamic brake
- If the operating temperature is over 40°C, refer to the power derating curves of B3 motors on page 37.

- Please follow the max. tolerant loading of the motor shaft end listed below during operation

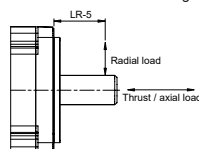

ECM-B3H Series Servo Motor Specifications

Electrical Specifications - 200 V

	ECM-B3H-F \square 1308	ECM-B3H-F \square 1313	ECM-B3H-F \square 1318
Rated Power (kW)	0.85	1.3	1.8
Rated Torque (N-m) ²	5.39	8.34	11.5
Maximum Torque (N-m)	16.17	25.02	34.5
Rated Speed (rpm)	1,500		
Maximum Speed (rpm)	4,000		
Rated Current (Arms)	6.65	7.7	11.5
Max. Instantaneous Current (Arms)	20	23.9	36.1
Rated Power Rate (kW/s)	23.4	38.6	58.5
Rated Power Rate (kW/s) with brake	23	38.3	58
Rotor Inertia ($\times 10^{-4}$ kg.m ²)	12.44	18	22.6
Rotor Inertia ($\times 10^{-4}$ kg.m ²) with brake	12.62	18.14	22.8
Mechanical Time Constant (ms)	2.48	1.98	1.7
Mechanical Time Constant (ms) with brake	2.52	1.99	1.71
Torque Constant -KT (N-m/A)	0.811	1.08	1
Voltage Constant -KE (mV/(rpm))	29.8	38.8	35.3
Armature Resistance (Ohm)	0.46	0.44	0.253
Armature Inductance (mH)	2.5	2.76	1.7
Electrical Time Constant (ms)	5.43	6.27	6.72
Weight – without brake (kg)	6	7	8
Weight – with brake (kg)	7.5	8.5	9.5
Max. Radial Loading (N) ⁵	490	686	980
Max. Axial Loading (N) ⁵	98	343	392
Brake Working Voltage	24 V _{DC} \pm 10%		
Brake Power Consumption (at 20°C)[W]	17.6	17.6	17.6
Brake Holding Torque [Nt-m (min)] ³	9.5	9.5	9.5
Brake Release Time [ms (Max)]	60	60	60
Brake Pull-In Time [ms (Max)]	120	120	120
Derating (%) (with oil seal)	5	5	5
Torque Feature (T-N Curve)			
Insulation Class	Class A (UL), Class B (CE)		
Insulation Resistance	> 100 M Ω , DC 500V		
Insulation Strength	1.8 kVac, 1 sec		
Vibration Level (μ m)	V15		
Operating Temperature	-20°C ~ 60°C*4		
Storage Temperature	-20°C ~ 80°C		
Storage & Operation Humidity	20 ~ 90%RH (non-condensing)		
Vibration Capacity	2.5 G		
IP Rating	IP67 (when using waterproof connections and when an oil seal is fitted to the rotating shaft (for an oil seal model))		
Certifications			

Notes:

- In the servo motor model name, \square represents the motor inertia and \square represents the encoder type.
- The rated torque is the continuous permissible torque between 0 to 40°C operating temperature which is suitable for the servo motor mounted with the following heat sink dimensions.
 F100: 300 mm x 300 mm x 12 mm
 F130: 400 mm x 400 mm x 20 mm
 Material: aluminum
- The built-in servo motor brake is only for keeping the object in a stopped state.
 Do not use it for deceleration or as a dynamic brake
- If the operating temperature is over 40°C, refer to the power derating curves of B3 motors on page 37.

- Please follow the max. tolerating loading of the motor shaft end listed below during operation

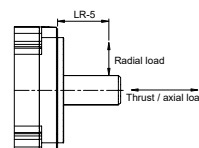

ECM-B3H Series Servo Motor Specifications

Electrical Specifications - 200 V

	ECM-B3H-L [2] 1308	ECM-B3H-L [2] 1313	ECM-B3H-L [2] 1318
Rated Power (kW)	0.85	1.3	1.8
Rated Torque (N-m) ^{*2}	5.39	8.34	11.5
Maximum Torque (N-m)	16.17	25.02	34.5
Rated Speed (rpm)	1,500		
Maximum Speed (rpm)	4,000		
Rated Current (Arms)	3.35	3.85	5.75
Max. Instantaneous Current (Arms)	10	12	18.1
Rated Power Rate (kW/s)	23.4	38.6	58.5
Rated Power Rate (kW/s) with brake	23	38.3	58
Rotor Inertia ($\times 10^{-4}$ kg.m ²)	12.44	18	22.6
Rotor Inertia ($\times 10^{-4}$ kg.m ²) with brake	12.62	18.14	22.8
Mechanical Time Constant (ms)	2.5	1.97	1.69
Mechanical Time Constant (ms) with brake	2.54	1.99	1.71
Torque Constant -KT (N-m/A)	1.61	2.17	2
Voltage Constant -KE (mV/(rpm))	59.5	77.6	70.7
Armature Resistance (Ohm)	1.84	1.76	1.01
Armature Inductance (mH)	10	11	6.8
Electrical Time Constant (ms)	5.43	6.25	6.73
Weight – without brake (kg)	6	7	8
Weight – with brake (kg)	7.5	8.5	9.5
Max. Radial Loading (N) ^{*5}	490	686	980
Max. Axial Loading (N) ^{*5}	98	343	392
Brake Working Voltage	24 V _{DC} \pm 10%		
Brake Power Consumption (at 20°C)[W]	24	24	24
Brake Holding Torque [Nt-m (min)] ^{*3}	16	16	16
Brake Release Time [ms (Max)]	60	60	60
Brake Pull-In Time [ms (Max)]	120	120	120
Derating (%) (with oil seal)	5	5	5
Torque Feature (T-N Curve)	<p>ASD-B3H-1543- [2] ASD-B3H-1503- [2]</p>	<p>ASD-B3H-2043- [2] ASD-B3H-1543- [2]</p>	<p>ASD-B3H-2043- [2] ASD-B3H-1543- [2]</p>
Insulation Class	Class A (UL), Class B (CE)		
Insulation Resistance	> 100 M Ω , DC 500V		
Insulation Strength	1.8 kVac, 1 sec		
Vibration Level (μ m)	V15		
Operating Temperature	-20°C ~ 60°C*4		
Storage Temperature	-20°C ~ 80°C		
Storage & Operation Humidity	20 ~ 90%RH (non-condensing)		
Vibration Capacity	2.5 G		
IP Rating	IP67 (when using waterproof connections and when an oil seal is fitted to the rotating shaft (for an oil seal model))		
Certifications			

Notes:

- In the servo motor model name, [1] represents the motor inertia and [2] represents the encoder type.
- The rated torque is the continuous permissible torque between 0 to 40°C operating temperature which is suitable for the servo motor mounted with the following heat sink dimensions.
F100: 300 mm x 300 mm x 12 mm
F130: 400 mm x 400 mm x 20 mm
Material: aluminum
- The built-in servo motor brake is only for keeping the object in a stopped state.
Do not use it for deceleration or as a dynamic brake
- If the operating temperature is over 40°C, refer to the power derating curves of B3 motors on page 37.

- Please follow the max. tolerant loading of the motor shaft end listed below during operation

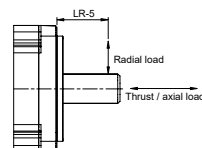

ECM-B3M Series Servo Motor Specifications

Electrical Specifications - 200 V

	ECM-B3M - C 0602	ECM-B3M - C 0604
Rated Power (kW)	0.2	0.4
Rated Torque (N-m) ^{*2}	0.64	1.27
Maximum Torque (N-m)	2.24	4.45
Rated Speed (rpm)	3,000	
Maximum Speed (rpm)	6,000	
Rated Current (Arms)	1.42	2.40
Max. Instantaneous Current (Arms)	6.62	9.47
Rated Power Rate (kW/s)	29.05	63.50
Rated Power Rate (kW/s) with brake	27.13	61.09
Rotor Inertia ($\times 10^{-4}$ kg.m ²)	0.141	0.254
Rotor Inertia ($\times 10^{-4}$ kg.m ²) with brake	0.151	0.264
Mechanical Time Constant (ms)	0.91	0.52
Mechanical Time Constant (ms) with brake	0.97	0.54
Torque Constant -KT (N-m/A)	0.45	0.53
Voltage Constant -KE (mV/(rpm))	16.96	19.76
Armature Resistance (Ohm)	4.71	2.04
Armature Inductance (mH)	12.18	6.50
Electrical Time Constant (ms)	2.59	3.19
Weight – without brake (kg)	0.9	1.2
Weight – with brake (kg)	1.3	1.6
Max. Radial Loading (N) ^{*5}	245	245
Max. Axial Loading (N) ^{*5}	74	74
Brake Working Voltage	24 V _{DC} \pm 10%	
Brake Power Consumption (at 20°C)[W]	7.6	7.6
Brake Holding Torque [Nt-m (min)] ^{*3}	1.3	1.3
Brake Release Time [ms (Max)]	20	20
Brake Pull-In Time [ms (Max)]	50	50
Derating (%) (with oil seal)	10	5
Torque Feature (T-N Curve)		
Insulation Class	Class A (UL), Class B (CE)	
Insulation Resistance	> 100 M Ω , DC 500V	
Insulation Strength	1.8 kVac, 1 sec	
Vibration Level (μ m)	V15	
Operating Temperature	-20°C ~ 60°C ^{*4}	
Storage Temperature	-20°C ~ 80°C	
Storage & Operation Humidity	20 ~ 90%RH (non-condensing)	
Vibration Capacity	2.5 G	
IP Rating	IP67 (when using waterproof connections and when an oil seal is fitted to the rotating shaft (for an oil seal model))	
Certifications		

Notes:

- In the servo motor model name, [1] represents the motor inertia and [2] represents the encoder type.
- The rated torque is the continuous permissible torque between 0 to 40°C operating temperature which is suitable for the servo motor mounted with the following heat sink dimensions.
F100: 300 mm x 300 mm x 12 mm
F130: 400 mm x 400 mm x 20 mm
Material: aluminum
- The built-in servo motor brake is only for keeping the object in a stopped state.
Do not use it for deceleration or as a dynamic brake
- If the operating temperature is over 40°C, refer to the power derating curves of B3 motors on page 37.

- Please follow the max. tolerant loading of the motor shaft end listed below during operation

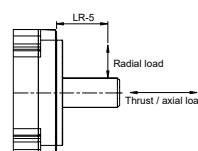

ECM-B3M Series Servo Motor Specifications

Electrical Specifications - 200 V

	ECM-B3M-C ② 0807	ECM-B3M-C ② 0810
Rated Power (kW)	0.75	1
Rated Torque (N-m) ^{*2}	2.4	3.18
Maximum Torque (N-m)	8.4	11.13
Rated Speed (rpm)	3,000	
Maximum Speed (rpm)	6,000	
Rated Current (Arms)	4.27	5
Max. Instantaneous Current (Arms)	15.8	18.2
Rated Power Rate (kW/s)	53.83	73.8
Rated Power Rate (kW/s) with brake	50.97	72.2
Rotor Inertia ($\times 10^{-4}$ kg.m ²)	1.07	1.37
Rotor Inertia ($\times 10^{-4}$ kg.m ²) with brake	1.13	1.4
Mechanical Time Constant (ms)	0.54	0.48
Mechanical Time Constant (ms) with brake	0.57	0.49
Torque Constant -KT (N-m/A)	0.56	0.64
Voltage Constant -KE (mV/(rpm))	20.17	23.15
Armature Resistance (Ohm)	0.55	0.495
Armature Inductance (mH)	2.81	2.63
Electrical Time Constant (ms)	5.11	5.31
Weight – without brake (kg)	2.34	2.82
Weight – with brake (kg)	3.15	3.6
Max. Radial Loading (N) ^{*5}	392	392
Max. Axial Loading (N) ^{*5}	147	147
Brake Working Voltage	24 V _{DC} \pm 10%	24 V _{DC} \pm 10%
Brake Power Consumption (at 20°C)[W]	8	10
Brake Holding Torque [Nt-m (min)] ^{*3}	2.5	3.8
Brake Release Time [ms (Max)]	20	40
Brake Pull-In Time [ms (Max)]	60	80
Derating (%) (with oil seal)	5	5
Torque Feature (T-N Curve)		
Insulation Class	Class A (UL), Class B (CE)	
Insulation Resistance	> 100 M Ω , DC 500V	
Insulation Strength	1.8 kVac, 1 sec	
Vibration Level (μ m)	V15	
Operating Temperature	-20°C ~ 60°C ^{*4}	
Storage Temperature	-20°C ~ 80°C	
Storage & Operation Humidity	20 ~ 90%RH (non-condensing)	
Vibration Capacity	2.5 G	
IP Rating	IP67 (when using waterproof connections and when an oil seal is fitted to the rotating shaft (for an oil seal model))	
Certifications		

Notes:

- In the servo motor model name, ① represents the motor inertia and ② represents the encoder type.
- The rated torque is the continuous permissible torque between 0 to 40°C operating temperature which is suitable for the servo motor mounted with the following heat sink dimensions.
F100: 300 mm x 300 mm x 12 mm
F130: 400 mm x 400 mm x 20 mm
Material: aluminum
- The built-in servo motor brake is only for keeping the object in a stopped state.
Do not use it for deceleration or as a dynamic brake
- If the operating temperature is over 40°C, refer to the power derating curves of B3 motors on page 37.

- Please follow the max. tolerating loading of the motor shaft end listed below during operation

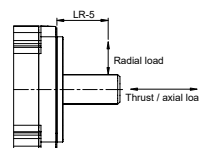

ECM-B3M Series Servo Motor Specifications 電氣規

Electrical Specifications - 200 V

	ECM-B3M-C 1010	ECM-B3M-C 1015	ECM-B3M-C 1020
Rated Power (kW)	1	1.5	2
Rated Torque (N-m) ²	3.18	4.77	6.37
Maximum Torque (N-m)	9.54	14.3	19.1
Rated Speed (rpm)	3,000		
Maximum Speed (rpm)	6,000		
Rated Current (Arms)	6.05	7.48	9.96
Max. Instantaneous Current (Arms)	18.4	22.8	30.7
Rated Power Rate (kW/s)	36.4	61.7	86.7
Rated Power Rate (kW/s) with brake	33	57.3	82
Rotor Inertia ($\times 10^{-4}$ kg.m ²)	2.78	3.69	4.68
Rotor Inertia ($\times 10^{-4}$ kg.m ²) with brake	3.06	3.97	4.95
Mechanical Time Constant (ms)	0.741	0.552	0.523
Mechanical Time Constant (ms) with brake	0.815	0.594	0.554
Torque Constant -KT (N-m/A)	0.526	0.638	0.64
Voltage Constant -KE (mV/(rpm))	19.8	23.8	23.7
Armature Resistance (Ohm)	0.265	0.217	0.162
Armature Inductance (mH)	1.86	1.71	1.23
Electrical Time Constant (ms)	7.02	7.88	7.59
Weight – without brake (kg)	3.56	4.37	5.09
Weight – with brake (kg)	4.88	5.68	6.51
Max. Radial Loading (N) ⁵	490	490	490
Max. Axial Loading (N) ⁵	196	196	196
Brake Working Voltage	24 V _{DC} \pm 10%		
Brake Power Consumption (at 20°C)[W]	17.6	17.6	17.6
Brake Holding Torque [Nt-m (min)] ^{*3}	9.5	9.5	9.5
Brake Release Time [ms (Max)]	50	50	50
Brake Pull-In Time [ms (Max)]	110	110	110
Derating (%) (with oil seal)	5	5	5
Torque Feature (T-N Curve)			
Insulation Class	Class F (UL), Class F (CE)		
Insulation Resistance	> 100 M Ω , DC 500 V		
Insulation Strength	1.8k Vac, 1 sec		
Vibration Level (μ m)	V15		
Operating Temperature	-20°C - 60°C*4		
Storage Temperature	-20°C - 80°C		
Storage & Operation Humidity	20 - 90%RH (non-condensing)		
Vibration Capacity	2.5 G		
IP Rating	IP67 (when using waterproof connections and when an oil seal is fitted to the rotating shaft (for an oil seal model))		
Certifications			

Notes:

- In the servo motor model name, 2 represents the encoder type.
- The rated torque is the continuous permissible torque between 0 to 40°C operating temperature which is suitable for the servo motor mounted with the following heat sink dimensions.
F130: 400 mm x 400 mm x 20 mm
Material: aluminum
- The built-in servo motor brake is only for keeping the object in a stopped state.
- If the operating temperature is over 40°C, refer to the power derating curves of B3 motors on page 37.

- Please follow the max. tolerant loading of the motor shaft end listed below during operation

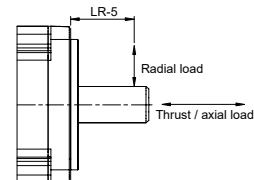

ECM-B3M Series Servo Motor Specifications

Electrical Specifications - 200 V

	ECM-B3M-E 2 1310	ECM-B3M-E 2 1315	ECM-B3M-E 2 1320
Rated Power (kW)	1	1.5	2
Rated Torque (N-m) ^{*2}	4.77	7.16	9.55
Maximum Torque (N-m)	14.3	21.48	28.65
Rated Speed (rpm)	2,000		
Maximum Speed (rpm)	3,000		
Rated Current (Arms)	5.96	8.17	10.59
Max. Instantaneous Current (Arms)	19.9	26.82	34.2
Rated Power Rate (kW/s)	29.21	45.69	62.25
Rated Power Rate (kW/s) with brake	28.66	45.09	61.62
Rotor Inertia ($\times 10^{-4}$ kg.m ²)	7.79	11.22	14.65
Rotor Inertia ($\times 10^{-4}$ kg.m ²) with brake	7.94	11.37	14.8
Mechanical Time Constant (ms)	1.46	1.1	1.03
Mechanical Time Constant (ms) with brake	1.49	1.12	1.04
Torque Constant -KT (N-m/A)	0.8	0.88	0.9
Voltage Constant -KE (mV/(rpm))	29.3	31.69	32.7
Armature Resistance (Ohm)	0.419	0.26	0.198
Armature Inductance (mH)	4	2.81	2.18
Electrical Time Constant (ms)	9.55	10.81	11.01
Weight – without brake (kg)	4.9	6.7	7
Weight – with brake (kg)	6.3	7.4	8.5
Max. Radial Loading (N) ^{*5}	490	686	980
Max. Axial Loading (N) ^{*5}	98	343	392
Brake Working Voltage	24 V _{DC} \pm 10%		
Brake Power Consumption (at 20°C)[W]	21.5	21.5	21.5
Brake Holding Torque [Nt-m (min)] ^{*3}	10	10	10
Brake Release Time [ms (Max)]	50	50	50
Brake Pull-In Time [ms (Max)]	110	110	110
Derating (%) (with oil seal)	5	5	5
Torque Feature (T-N Curve)			
Insulation Class	Class A (UL), Class B (CE)		
Insulation Resistance	> 100 M Ω , DC 500V		
Insulation Strength	1.8 kVac, 1 sec		
Vibration Level (μ m)	V15		
Operating Temperature	-20°C ~ 60°C* ⁴		
Storage Temperature	-20°C ~ 80°C		
Storage & Operation Humidity	20 ~ 90%RH (non-condensing)		
Vibration Capacity	2.5 G		
IP Rating	IP67 (when using waterproof connections and when an oil seal is fitted to the rotating shaft (for an oil seal model))		
Certifications			

Notes:

- In the servo motor model name, 2 represents the encoder type.
- The rated torque is the continuous permissible torque between 0 to 40°C operating temperature which is suitable for the servo motor mounted with the following heat sink dimensions.
F180: 550 mm x 550 mm x 30 mm
Material: aluminum
- The built-in servo motor brake is only for keeping the object in a stopped state.
- If the operating temperature is over 40°C, refer to the power derating curves of B3 motors on page 37.

- Please follow the max. tolerant loading of the motor shaft end listed below during operation

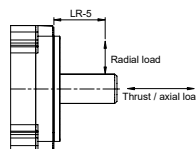

ECM-B3M Series Servo Motor Specifications 電氣規

Electrical Specifications - 200 V

	ECM-B3M-E □ 1820	ECM-B3M-F □ 1830
Rated Power (kW)	2	3
Rated Torque (N-m) ²	9.55	19.1
Maximum Torque (N-m)	28.65	57.29
Rated Speed (rpm)	2,000	1,500
Maximum Speed (rpm)	3,000	3,000
Rated Current (Arms)	11.43	18.21
Max. Instantaneous Current (Arms)	36.21	58.9
Rated Power Rate (kW/s)	31.33	68.02
Rated Power Rate (kW/s) with brake	30.02	66.45
Rotor Inertia (×10 ⁻⁴ kg.m ²)	29.11	53.63
Rotor Inertia (×10 ⁻⁴ kg.m ²) with brake	30.38	54.9
Mechanical Time Constant (ms)	1.83	1.21
Mechanical Time Constant (ms) with brake	1.91	1.24
Torque Constant -KT (N-m/A)	0.836	1.05
Voltage Constant -KE (mV/(rpm))	31.6	37.9
Armature Resistance (Ohm)	0.159	0.086
Armature Inductance (mH)	2.34	1.52
Electrical Time Constant (ms)	14.72	17.67
Weight - without brake (kg)	10	13.9
Weight - with brake (kg)	13.7	17.6
Max. Radial Loading (N) ⁵	1470	1470
Max. Axial Loading (N) ⁵	490	490
Brake Working Voltage	24 V _{DC} ± 10%	
Brake Power Consumption (at 20°C)[W]	31	31
Brake Holding Torque [Nt-m (min)] ³	25	55
Brake Release Time [ms (Max)]	30	50
Brake Pull-In Time [ms (Max)]	120	150
Derating (%) (with oil seal)	0	5
Torque Feature (T-N Curve)		
Insulation Class	Class A (UL), Class B (CE)	
Insulation Resistance	> 100 MΩ, DC 500 V	
Insulation Strength	2.3 k Vac, 1 sec	
Vibration Level (μm)	V15	
Operating Temperature	-20°C ~ 60°C*4	
Storage Temperature	-20°C ~ 80°C	
Storage & Operation Humidity	20 ~ 90% RH (non-condensing)	
Vibration Capacity	2.5 G	
IP Rating	IP67 (when using waterproof connections and when an oil seal is fitted to the rotating shaft (for an oil seal model))	
Certifications		

Notes:

- In the servo motor model name, 2 represents the encoder type.
- The rated torque is the continuous permissible torque between 0 to 40°C operating temperature which is suitable for the servo motor mounted with the following heat sink dimensions.
F130: 400 mm x 400 mm x 20 mm
Material: aluminum
- The built-in servo motor brake is only for keeping the object in a stopped state.
- If the operating temperature is over 40°C, refer to the power derating curves of B3 motors on page 37.

- Please follow the max. tolerant loading of the motor shaft end listed below during operation

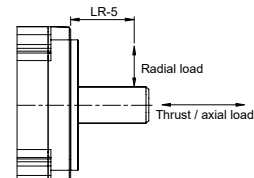

ECM-B3M Series Servo Motor Specifications

Electrical Specifications - 400 V

	ECM-B3M-J 2 0604	ECM-B3M-J 2 0807
Rated Power (kW)	0.4	0.75
Rated Torque (N-m) ¹²	1.27	2.4
Maximum Torque (N-m)	4.45	8.4
Rated Speed (rpm)	3,000	
Maximum Speed (rpm)	6,000	
Rated Current (Arms)	1.35	2.15
Max. Instantaneous Current (Arms)	5.2	7.9
Rated Power Rate (kW/s)	63.5	53.83
Rated Power Rate (kW/s) with brake	61.09	50.97
Rotor Inertia ($\times 10^{-4}$ kg.m ²)	0.254	1.07
Rotor Inertia ($\times 10^{-4}$ kg.m ²) with brake	0.264	1.13
Mechanical Time Constant (ms)	0.53	0.55
Mechanical Time Constant (ms) with brake	0.55	0.58
Torque Constant -KT (N-m/A)	0.94	1.12
Voltage Constant -KE (mV/(rpm))	34.66	40.34
Armature Resistance (Ohm)	6.47	2.2
Armature Inductance (mH)	20.6	11.2
Electrical Time Constant (ms)	3.18	5.09
Weight – without brake (kg)	1.2	2.34
Weight – with brake (kg)	1.6	3.15
Max. Radial Loading (N) ¹⁵	245	392
Max. Axial Loading (N) ¹⁵	74	147
Brake Working Voltage	24 V _{DC} \pm 10%	
Brake Power Consumption (at 20°C)[W]	7.6	8
Brake Holding Torque [Nt-m (min)] ¹³	1.3	2.5
Brake Release Time [ms (Max)]	20	20
Brake Pull-In Time [ms (Max)]	50	60
Derating (%) (with oil seal)	5	5
Torque Feature (T-N Curve)		
Insulation Class	Class A (UL), Class B (CE)	
Insulation Resistance	> 100 M Ω , DC 500 V	
Insulation Strength	2.3 k Vac, 1 sec	
Vibration Level (μ m)	V15	
Operating Temperature	-20°C ~ 60°C*4	
Storage Temperature	-20°C ~ 80°C	
Storage & Operation Humidity	20 ~ 90% RH (non-condensing)	
Vibration Capacity	2.5 G	
IP Rating	IP67 (when using waterproof connections and when an oil seal is fitted to the rotating shaft (for an oil seal model))	
Certifications		

Notes:

- In the servo motor model name, 2 represents the encoder type.
- The rated torque is the continuous permissible torque between 0 to 40°C operating temperature which is suitable for the servo motor mounted with the following heat sink dimensions.
F100: 300 mm x 300 mm x 12 mm
F130: 400 mm x 400 mm x 20 mm
Material: aluminum
- The built-in servo motor brake is only for keeping the object in a stopped state.
- If the operating temperature is over 40°C, refer to the power derating curves of B3 motors on page 37.

- Please follow the max. tolerant loading of the motor shaft end listed below during operation

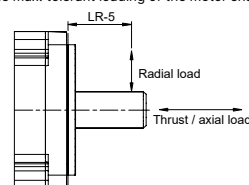

ECM-B3M Series Servo Motor Specifications

Electrical Specifications - 400 V

	ECM-B3M-J 1010	ECM-B3M-J 1015	ECM-B3M-J 1020																																							
Rated Power (kW)	1	1.5	2																																							
Rated Torque (N-m) ²	3.18	4.77	6.37																																							
Maximum Torque (N-m)	9.54	14.3	19.1																																							
Rated Speed (rpm)	3,000																																									
Maximum Speed (rpm)	6,000																																									
Rated Current (Arms)	3.03	3.73	5																																							
Max. Instantaneous Current (Arms)	9.21	11.4	15.3																																							
Rated Power Rate (kW/s)	36.4	61.7	86.7																																							
Rated Power Rate (kW/s) with brake	33	57.3	82																																							
Rotor Inertia ($\times 10^{-4}$ kg.m ²)	2.78	3.69	4.68																																							
Rotor Inertia ($\times 10^{-4}$ kg.m ²) with brake	3.06	3.97	4.95																																							
Mechanical Time Constant (ms)	0.737	0.546	0.528																																							
Mechanical Time Constant (ms) with brake	0.811	0.587	0.559																																							
Torque Constant -KT (N-m/A)	1.05	1.28	1.27																																							
Voltage Constant -KE (mV/(rpm))	39.5	47.8	47.2																																							
Armature Resistance (Ohm)	1.05	0.864	0.646																																							
Armature Inductance (mH)	7.5	6.63	4.89																																							
Electrical Time Constant (ms)	7.14	7.67	7.57																																							
Weight - without brake (kg)	3.56	4.37	5.09																																							
Weight - with brake (kg)	4.88	5.68	6.505																																							
Max. Radial Loading (N) ⁵	490	490	490																																							
Max. Axial Loading (N) ⁵	196	196	196																																							
Brake Working Voltage	24 V _{DC} \pm 10%																																									
Brake Power Consumption (at 20°C)[W]	17.6	17.6	17.6																																							
Brake Holding Torque [Nt-m (min)] ³	9.5	9.5	9.5																																							
Brake Release Time [ms (Max)]	50	50	50																																							
Brake Pull-In Time [ms (Max)]	110	110	110																																							
Derating (%) (with oil seal)	5	5	5																																							
Torque Feature (T-N Curve)	<p>Legend: ASD-B3M-1543-J (solid line), ASD-B3M-1043-J (dashed line)</p> <table border="1"> <caption>Torque vs Speed Data for ASD-B3M-1543-J</caption> <thead> <tr> <th>Speed (rpm)</th> <th>Intermittent Duty Zone (N-m)</th> <th>Continuous Duty Zone (N-m)</th> </tr> </thead> <tbody> <tr> <td>3000</td> <td>9.54 (300%)</td> <td>3.18 (100%)</td> </tr> <tr> <td>4400</td> <td>8.7 (274%)</td> <td>1.59 (50%)</td> </tr> <tr> <td>4700</td> <td>7.4 (233%)</td> <td>-</td> </tr> <tr> <td>6000</td> <td>7.08 (223%)</td> <td>-</td> </tr> </tbody> </table>	Speed (rpm)	Intermittent Duty Zone (N-m)	Continuous Duty Zone (N-m)	3000	9.54 (300%)	3.18 (100%)	4400	8.7 (274%)	1.59 (50%)	4700	7.4 (233%)	-	6000	7.08 (223%)	-	<table border="1"> <caption>Torque vs Speed Data for ASD-B3M-1015</caption> <thead> <tr> <th>Speed (rpm)</th> <th>Intermittent Duty Zone (N-m)</th> <th>Continuous Duty Zone (N-m)</th> </tr> </thead> <tbody> <tr> <td>3000</td> <td>14.31 (300%)</td> <td>4.77 (100%)</td> </tr> <tr> <td>3800</td> <td>11.4 (239%)</td> <td>2.39 (50%)</td> </tr> <tr> <td>6000</td> <td>-</td> <td>-</td> </tr> </tbody> </table>	Speed (rpm)	Intermittent Duty Zone (N-m)	Continuous Duty Zone (N-m)	3000	14.31 (300%)	4.77 (100%)	3800	11.4 (239%)	2.39 (50%)	6000	-	-	<table border="1"> <caption>Torque vs Speed Data for ASD-B3M-1020</caption> <thead> <tr> <th>Speed (rpm)</th> <th>Intermittent Duty Zone (N-m)</th> <th>Continuous Duty Zone (N-m)</th> </tr> </thead> <tbody> <tr> <td>3000</td> <td>19.11 (300%)</td> <td>6.37 (100%)</td> </tr> <tr> <td>3800</td> <td>15.2 (239%)</td> <td>3.19 (50%)</td> </tr> <tr> <td>6000</td> <td>-</td> <td>-</td> </tr> </tbody> </table>	Speed (rpm)	Intermittent Duty Zone (N-m)	Continuous Duty Zone (N-m)	3000	19.11 (300%)	6.37 (100%)	3800	15.2 (239%)	3.19 (50%)	6000	-	-
Speed (rpm)	Intermittent Duty Zone (N-m)	Continuous Duty Zone (N-m)																																								
3000	9.54 (300%)	3.18 (100%)																																								
4400	8.7 (274%)	1.59 (50%)																																								
4700	7.4 (233%)	-																																								
6000	7.08 (223%)	-																																								
Speed (rpm)	Intermittent Duty Zone (N-m)	Continuous Duty Zone (N-m)																																								
3000	14.31 (300%)	4.77 (100%)																																								
3800	11.4 (239%)	2.39 (50%)																																								
6000	-	-																																								
Speed (rpm)	Intermittent Duty Zone (N-m)	Continuous Duty Zone (N-m)																																								
3000	19.11 (300%)	6.37 (100%)																																								
3800	15.2 (239%)	3.19 (50%)																																								
6000	-	-																																								
Insulation Class	Class A (UL), Class B (CE)																																									
Insulation Resistance	> 100 M Ω , DC 500 V																																									
Insulation Strength	2.3 k Vac, 1 sec																																									
Vibration Level (μ m)	V15																																									
Operating Temperature	-20°C ~ 60°C*4																																									
Storage Temperature	-20°C ~ 80°C																																									
Storage & Operation Humidity	20 ~ 90% RH (non-condensing)																																									
Vibration Capacity	2.5 G																																									
IP Rating	IP67 (when using waterproof connections and when an oil seal is fitted to the rotating shaft (for an oil seal model))																																									
Certifications																																										

Notes:

- In the servo motor model name, 2 represents the encoder type.
- The rated torque is the continuous permissible torque between 0 to 40°C operating temperature which is suitable for the servo motor mounted with the following heat sink dimensions.
F130: 400 mm x 400 mm x 20 mm
Material: aluminum
- The built-in servo motor brake is only for keeping the object in a stopped state.
- If the operating temperature is over 40°C, refer to the power derating curves of B3 motors on page 37.

- Please follow the max. tolerating loading of the motor shaft end listed below during operation

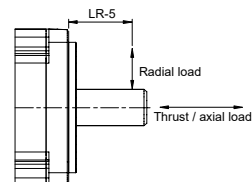

ECM-B3M Series Servo Motor Specifications

Electrical Specifications - 400 V

	ECM-B3M-K 1310	ECM-B3M-K 1315	ECM-B3M-K 1320
Rated Power (kW)	1	1.5	2
Rated Torque (N-m) ^{*2}	4.77	7.16	9.55
Maximum Torque (N-m)	14.3	21.48	28.65
Rated Speed (rpm)	2,000		
Maximum Speed (rpm)	3,000		
Rated Current (Arms)	3	4.09	5.3
Max. Instantaneous Current (Arms)	9.95	13.37	17.1
Rated Power Rate (kW/s)	29.21	45.69	62.25
Rated Power Rate (kW/s) with brake	28.66	45.09	61.62
Rotor Inertia (×10 ⁻⁴ kg.m ²)	7.79	11.22	14.65
Rotor Inertia (×10 ⁻⁴ kg.m ²) with brake	7.94	11.37	14.8
Mechanical Time Constant (ms)	1.47	1.1	1.03
Mechanical Time Constant (ms) with brake	1.5	1.12	1.04
Torque Constant -KT (N-m/A)	1.59	1.75	1.8
Voltage Constant -KE (mV/(rpm))	58.6	63.38	65.4
Armature Resistance (Ohm)	1.68	1.04	0.792
Armature Inductance (mH)	16	11.2	8.72
Electrical Time Constant (ms)	9.52	10.8	11
Weight – without brake (kg)	4.9	6	7
Weight – with brake (kg)	6.3	7.4	8.5
Max. Radial Loading (N) ^{*5}	490	686	980
Max. Axial Loading (N) ^{*5}	98	343	392
Brake Working Voltage	24 V _{DC} ± 10%		
Brake Power Consumption (at 20°C)[W]	21.5	21.5	21.5
Brake Holding Torque [Nt-m (min)] ^{*3}	10	10	10
Brake Release Time [ms (Max)]	50	50	50
Brake Pull-In Time [ms (Max)]	110	110	110
Derating (%) (with oil seal)	5	5	5
Torque Feature (T-N Curve)			
Insulation Class	Class A (UL), Class B (CE)		
Insulation Resistance	> 100 MΩ, DC 500 V		
Insulation Strength	2.3 k Vac, 1 sec		
Vibration Level (μm)	V15		
Operating Temperature	-20°C ~ 60°C ^{*4}		
Storage Temperature	-20°C ~ 80°C		
Storage & Operation Humidity	20 ~ 90% RH (non-condensing)		
Vibration Capacity	2.5 G		
IP Rating	IP67 (when using waterproof connections and when an oil seal is fitted to the rotating shaft (for an oil seal model))		
Certifications			

Notes:

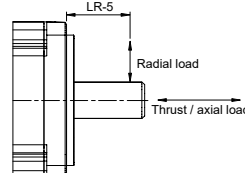

- In the servo motor model name, 2 represents the encoder type.
- The rated torque is the continuous permissible torque between 0 to 40°C operating temperature which is suitable for the servo motor mounted with the following heat sink dimensions.
F130: 400 mm x 400 mm x 20 mm
Material: aluminum
- The built-in servo motor brake is only for keeping the object in a stopped state.
- If the operating temperature is over 40°C, refer to the power derating curves of B3 motors on page 37.

- Please follow the max. tolerant loading of the motor shaft end listed below during operation

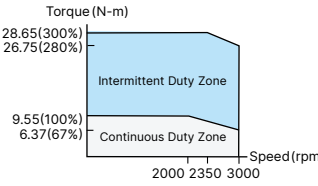
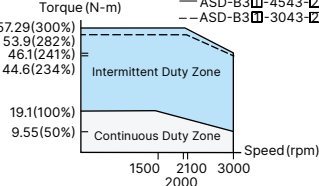
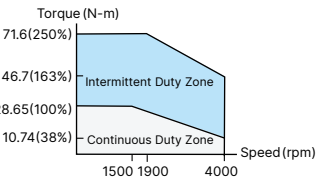

ECM-B3M Series Servo Motor Specifications

Electrical Specifications - 400 V

	ECM-B3M-K □ 1820	ECM-B3M-L □ 1830	ECM-B3M-L □ 1845
Rated Power (kW)	2	3	4.5
Rated Torque (N-m) ²	9.55	19.1	28.65
Maximum Torque (N-m)	28.65	57.29	71.6
Rated Speed (rpm)	2,000	1,500	1,500
Maximum Speed (rpm)	3,000	3,000	4,000
Rated Current (Arms)	5.7	9.1	13.3
Max. Instantaneous Current (Arms)	18.1	29.45	35.35
Rated Power Rate (kW/s)	31.33	68.02	121
Rated Power Rate (kW/s) with brake	30.02	66.45	119
Rotor Inertia (×10 ⁻⁴ kg.m ²)	29.11	53.63	67.73
Rotor Inertia (×10 ⁻⁴ kg.m ²) with brake	30.38	54.9	69.15
Mechanical Time Constant (ms)	1.83	1.21	1.07
Mechanical Time Constant (ms) with brake	1.91	1.24	1.09
Torque Constant -KT (N-m/A)	1.68	2.1	2.15
Voltage Constant -KE (mV/(rpm))	63.2	75.8	78.8
Armature Resistance (Ohm)	0.636	0.344	0.255
Armature Inductance (mH)	9.36	6.08	4.68
Electrical Time Constant (ms)	14.72	17.67	18.4
Weight – without brake (kg)	10	13.9	16.5
Weight – with brake (kg)	13.7	17.6	20.2
Max. Radial Loading (N) ⁵	1,470	1,470	1,470
Max. Axial Loading (N) ⁵	490	490	490
Brake Working Voltage	24 V _{DC} ± 10%		
Brake Power Consumption (at 20°C)[W]	31	31	31
Brake Holding Torque [Nt-m (min)] ³	25	25	55
Brake Release Time [ms (Max)]	30	30	50
Brake Pull-In Time [ms (Max)]	120	120	150
Derating (%) (with oil seal)	5	5	0
Torque Feature (T-N Curve)			
Insulation Class	Class A (UL), Class B (CE)		Class F (UL), Class F (CE)
Insulation Resistance	> 100 MΩ, DC 500 V		
Insulation Strength	2.3k Vac, 1 sec		
Vibration Level (μm)	V15		
Operating Temperature	-20°C ~ 60°C*4		
Storage Temperature	-20°C ~ 80°C		
Storage & Operation Humidity	20 ~ 90% RH (non-condensing)		
Vibration Capacity	2.5 G		
IP Rating	IP67 (when using waterproof connections and when an oil seal is fitted to the rotating shaft (for an oil seal model))		
Certifications			

Notes:

- In the servo motor model name, 2 represents the encoder type.
- The rated torque is the continuous permissible torque between 0 to 40°C operating temperature which is suitable for the servo motor mounted with the following heat sink dimensions.
F130: 400 mm x 400 mm x 20 mm
Material: aluminum
- The built-in servo motor brake is only for keeping the object in a stopped state.
- If the operating temperature is over 40°C, refer to the power derating curves of B3 motors on page 37.

- Please follow the max. tolerant loading of the motor shaft end listed below during operation

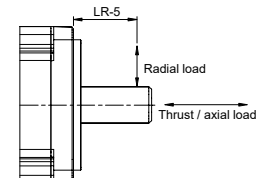

ECM-B3M Series Servo Motor Specifications

Electrical Specifications - 400 V

	ECM-B3M-L 2 1855	ECM-B3M-L 2 1875
Rated Power (kW)	5.5	7.5
Rated Torque (N-m) ^{*2}	35.01	47.75
Maximum Torque (N-m)	105	119
Rated Speed (rpm)	1,500	
Maximum Speed (rpm)	4,000	
Rated Current (Arms)	15.3	22.1
Max. Instantaneous Current (Arms)	49.29	56.68
Rated Power Rate (kW/s)	124	169
Rated Power Rate (kW/s) with brake	122	167
Rotor Inertia ($\times 10^{-4}$ kg.m ²)	98.88	134.95
Rotor Inertia ($\times 10^{-4}$ kg.m ²) with brake	100.1	136.24
Mechanical Time Constant (ms)	1.01	1.01
Mechanical Time Constant (ms) with brake	1.02	1.02
Torque Constant -KT (N-m/A)	2.29	2.16
Voltage Constant -KE (mV/(rpm))	81.8	77.4
Armature Resistance (Ohm)	0.182	0.12
Armature Inductance (mH)	3.48	2.27
Electrical Time Constant (ms)	19.1	18.9
Weight – without brake (kg)	21.2	27.2
Weight – with brake (kg)	24.9	30.9
Max. Radial Loading (N) ^{*5}	1764	1764
Max. Axial Loading (N) ^{*5}	588	588
Brake Working Voltage	24 V _{DC} \pm 10%	
Brake Power Consumption (at 20°C)[W]	31	31
Brake Holding Torque [Nt-m (min)] ^{*3}	55	55
Brake Release Time [ms (Max)]	50	50
Brake Pull-In Time [ms (Max)]	150	150
Derating (%) (with oil seal)	0	0
Torque Feature (T-N Curve)		
Insulation Class	Class F (UL), Class F (CE)	
Insulation Resistance	> 100 M Ω , DC 500 V	
Insulation Strength	2.3k Vac, 1 sec	
Vibration Level (μ m)	V 15	
Operating Temperature	-20°C ~ 60°C*4	
Storage Temperature	-20°C ~ 80°C	
Storage & Operation Humidity	20 ~ 90% RH (non-condensing)	
Vibration Capacity	2.5 G	
IP Rating	IP67 (when using waterproof connections and when an oil seal is fitted to the rotating shaft (for an oil seal model))	
Certifications		

Notes:

- In the servo motor model name, 2 represents the encoder type.
- The rated torque is the continuous permissible torque between 0 to 40°C operating temperature which is suitable for the servo motor mounted with the following heat sink dimensions.
F130: 400 mm x 400 mm x 20 mm
Material: aluminum
- The built-in servo motor brake is only for keeping the object in a stopped state.
- If the operating temperature is over 40°C, refer to the power derating curves of B3 motors on page 37.

- Please follow the max. tolerant loading of the motor shaft end listed below during operation

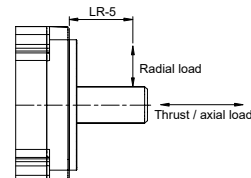

ECM-B3L Series Servo Motor Specifications

Electrical Specifications - 220 V

	ECM-B3L - C 0401
Rated Power (kW)	0.1
Rated Torque (N-m) ²	0.32
Maximum Torque (N-m)	1.12
Rated Speed (rpm)	3,000
Maximum Speed (rpm)	6,000
Rated Current (Arms)	0.857
Max. Instantaneous Current (Arms)	3.44
Rated Power Rate (kW/s)	34.25
Rated Power Rate (kW/s) with brake	32.51
Rotor Inertia ($\times 10^{-4}$ kg.m ²)	0.0299
Rotor Inertia ($\times 10^{-4}$ kg.m ²) with brake	0.0315
Mechanical Time Constant (ms)	0.5
Mechanical Time Constant (ms) with brake	0.53
Torque Constant -KT (N-m/A)	0.374
Voltage Constant -KE (mV/(rpm))	13.8
Armature Resistance (Ohm)	8.22
Armature Inductance (mH)	19.1
Electrical Time Constant (ms)	2.32
Weight – without brake (kg)	0.5
Weight – with brake (kg)	0.7
Max. Radial Loading (N) ⁵	78
Max. Axial Loading (N) ⁵	54
Brake Working Voltage	24 V _{DC} \pm 10%
Brake Power Consumption (at 20°C)[W]	6.1
Brake Holding Torque [Nt-m (min)] ³	0.3
Brake Release Time [ms (Max)]	20
Brake Pull-In Time [ms (Max)]	35
Derating (%) (with oil seal)	10
Torque Feature (T-N Curve)	
Insulation Class	Class A (UL), Class B (CE)
Insulation Resistance	> 100 M Ω , DC 500 V
Insulation Strength	1.8 k V _{AC} , 1 sec
Vibration Level (μ m)	V15
Operating Temperature	-20°C ~ 60°C ⁴
Storage Temperature	-20°C ~ 80°C
Storage & Operation Humidity	20 ~ 90% RH (non-condensing)
Vibration Capacity	2.5 G
IP Rating	IP67 (when using waterproof connections and when an oil seal is fitted to the rotating shaft (for an oil seal model))
Certifications	

Notes:

- In the servo motor model name, 2 represents the encoder type.
- The rated torque is the continuous permissible torque between 0 to 40°C operating temperature which is suitable for the servo motor mounted with the following heat sink dimensions.
F130: 400 mm x 400 mm x 20 mm
Material: aluminum
- The built-in servo motor brake is only for keeping the object in a stopped state.
- If the operating temperature is over 40°C, refer to the power derating curves of B3 motors on page 37.

- Please follow the max. tolerant loading of the motor shaft end listed below during operation

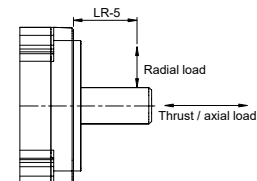

ECM-B3 Series Servo Motor Specifications

Power Derating Curves

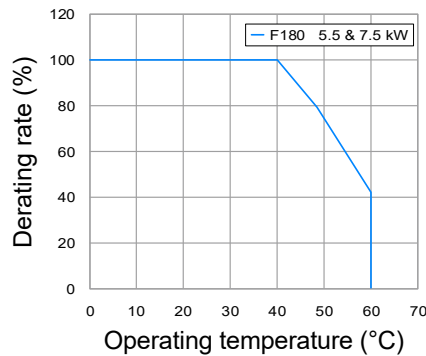
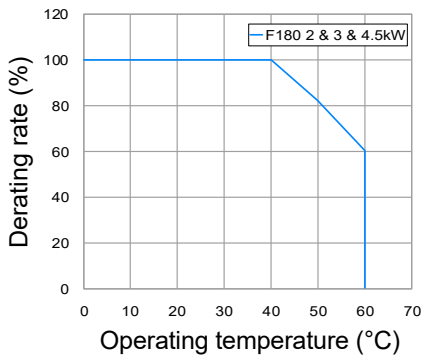
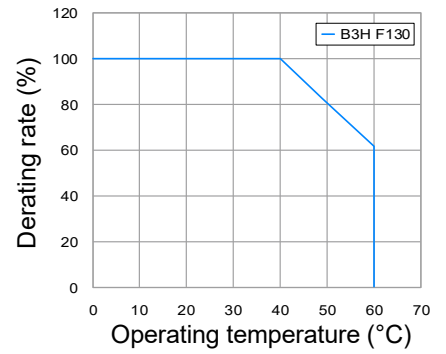
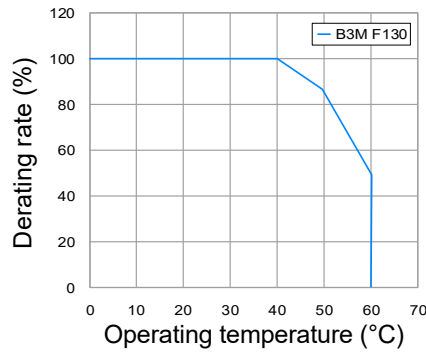
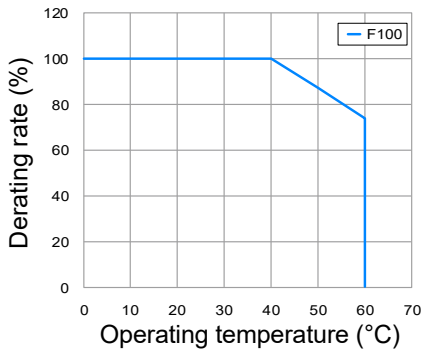
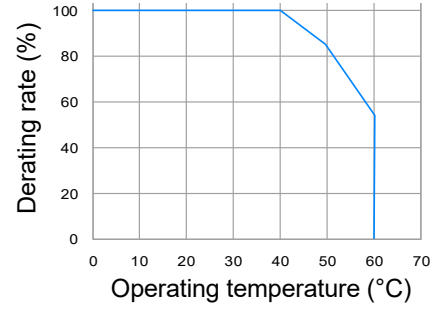
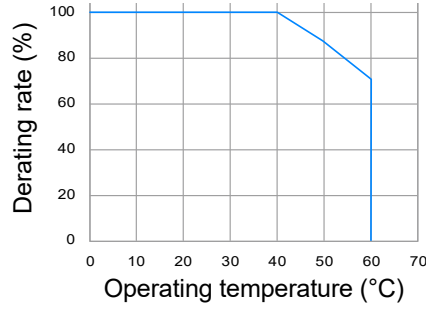
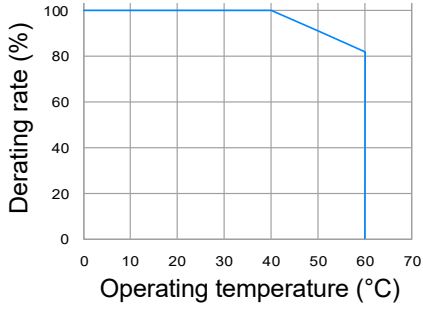

Note: Applicable for 220V and 400V models

ECM-B3 Built-in Series Servo Motor Specifications

220 V Dimensions of Motors with Frame Size of 80 mm or Below

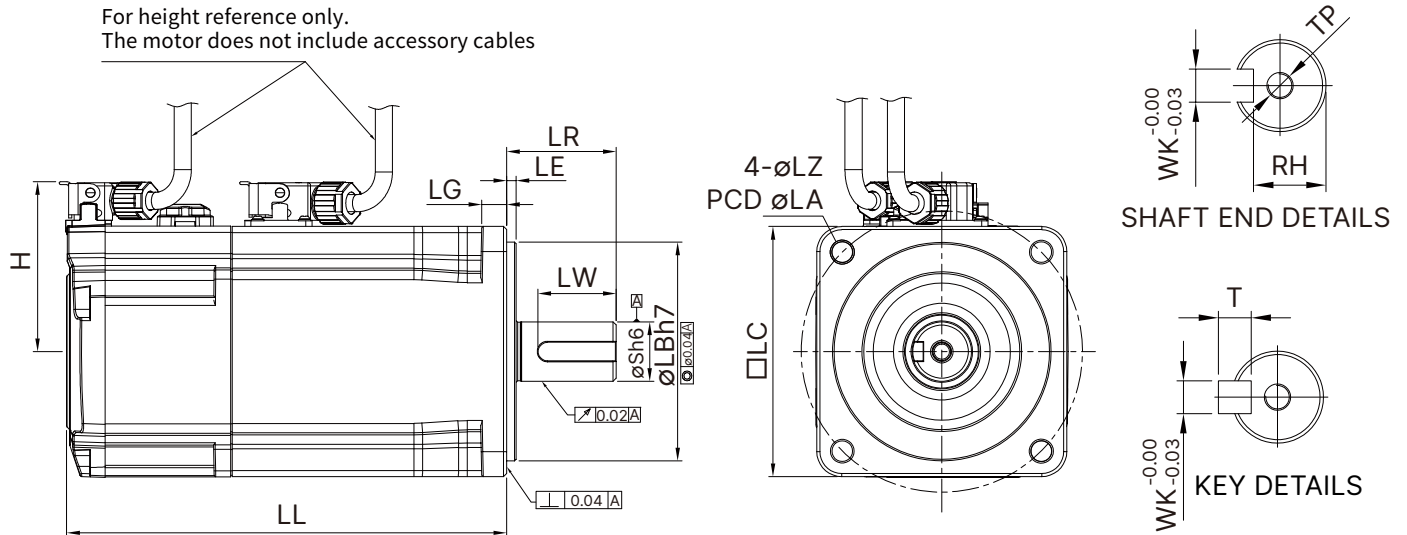

Model	B3L-C ② 0401	B3M-C ② 0602	B3M-C ② 0604	B3M-C ② 0807
LC	40	60	60	80
LZ	5.5	5.5	5.5	6.6
LA	70	70	70	90
S	14 ⁺⁰ _{-0.011}	14 ⁺⁰ _{-0.011}	14 ⁺⁰ _{-0.011}	19 ⁺⁰ _{-0.013}
LB	50 ⁺⁰ _{-0.025}	50 ⁺⁰ _{-0.025}	50 ⁺⁰ _{-0.025}	70 ⁺⁰ _{-0.030}
LL (w/o brake)	76.2	72.5	91	105.2
LL (with brake)	107.7	104.4	122.9	144.8
LH	300	300	300	300
LP	300	300	300	300
H	44	44	44	54
LR	30	30	30	35
LE	2.5	3	3	3
LG	7.5	7.5	7.5	8
LW	20	20	20	25
RH	11	11	11	15.5
WK	5	5	5	6
W	5	5	5	6
T	5	5	5	6
TP	M4 Depth 15	M4 Depth 15	M4 Depth 15	M6 Depth 20

Note: 1. Servo motor model name: ② = encoder type
2. The length of battery-less encoder frame LL increases as shown below

F40	F60	F80
+5.8 mm	+6.4 mm	+6 mm

ECM-B3 Built-in Series Servo Motor Specifications

220 V Dimensions of Motors with Frame Size of 80 mm or Below

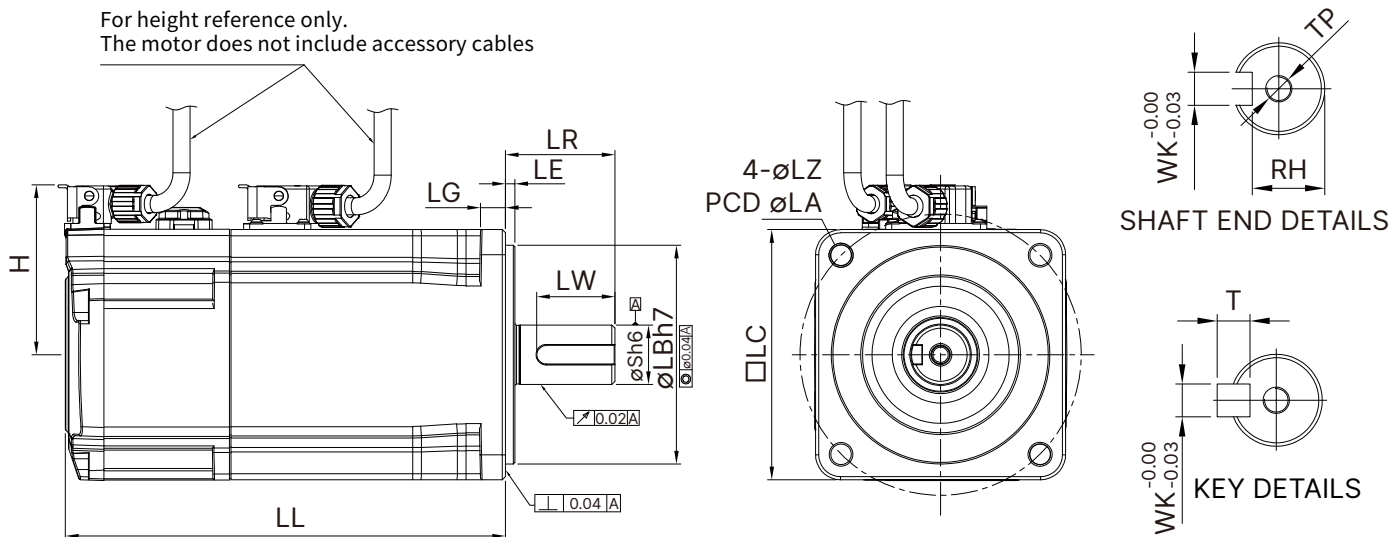

Model	B3M-C ② 0810	B3H-C ② 0602	B3H-C ② 0604	B3H-C ② 807
LC	80	60	60	80
LZ	6.6	5.5	5.5	6.6
LA	90	70	70	90
S	19($\begin{smallmatrix} +0 \\ -0.013 \end{smallmatrix}$)	14($\begin{smallmatrix} +0 \\ -0.011 \end{smallmatrix}$)	14($\begin{smallmatrix} +0 \\ -0.011 \end{smallmatrix}$)	19($\begin{smallmatrix} +0 \\ -0.013 \end{smallmatrix}$)
LB	70($\begin{smallmatrix} +0 \\ -0.030 \end{smallmatrix}$)	50($\begin{smallmatrix} +0 \\ -0.025 \end{smallmatrix}$)	50($\begin{smallmatrix} +0 \\ -0.025 \end{smallmatrix}$)	70($\begin{smallmatrix} +0 \\ -0.030 \end{smallmatrix}$)
LL (w/o brake)	118.8	69.6	87.45	95.4
LL (with brake)	154.4	101.5	119.35	131
LH	300	300	300	300
LP	300	300	300	300
H	54	44	44	54
LR	35	30	30	35
LE	3	3	3	3
LG	8	7.5	7.5	8
LW	25	20	20	25
RH	15.5	11	11	15.5
WK	6	5	5	6
W	6	5	5	6
T	6	5	5	6
TP	M6 Depth 20	M4 Depth 15	M4 Depth 15	M6 Depth 20

Note: 1. Servo motor model name: ② = encoder type
2. The length of battery-less encoder frame LL increases as shown below

F40	F60	F80
+5.8mm	+6.4mm	+6mm

ECM-B3 Series Servo Motor with Line Type Specifications

220V Dimensions of Motors with Frame Size of 80 mm

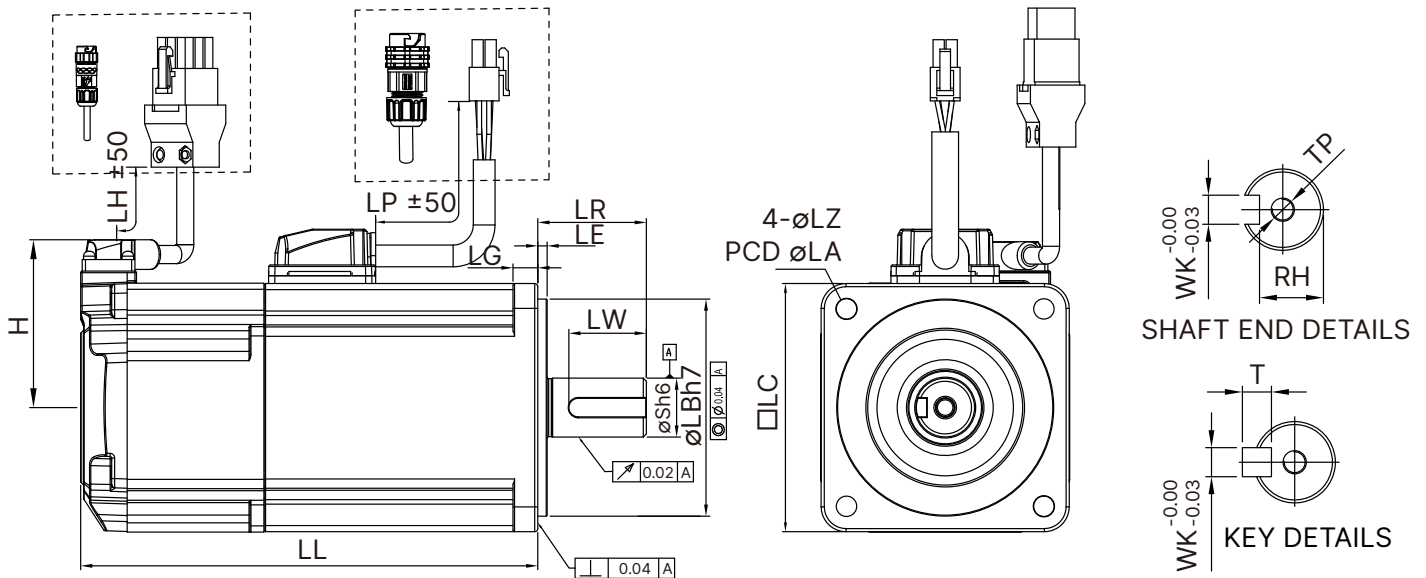

Model	B3L-C ② 0401	B3M-C ② 0602	B3M-C ② 0604	B3M-C ② 0807	B3M-C ② 0810
LC	40	60	60	80	80
LZ	4.5	5.5	5.5	6.6	6.6
LA	46	70	70	90	90
S	8(⁺⁰ / _{-0.009})	14(⁺⁰ / _{-0.011})	14(⁺⁰ / _{-0.011})	19(⁺⁰ / _{-0.013})	19(⁺⁰ / _{-0.013})
LB	30(⁺⁰ / _{-0.021})	50(⁺⁰ / _{-0.025})	50(⁺⁰ / _{-0.025})	70(⁺⁰ / _{-0.030})	70(⁺⁰ / _{-0.030})
LL (w/o brake)	77.6	72.5	91	105.2	118.7
LL (with brake)	111.7	109.4	127.9	144.8	158.3
LH	300	300	300	300	300
LP	300	300	300	300	300
H	40	48.5	48.5	58.5	58.5
LR	25	30	30	35	35
LE	2.5	3	3	3	3
LG	5	7.5	7.5	8	8
LW	16	20	20	25	25
RH	6.2	11	11	15.5	15.5
WK	3	5	5	6	6
W	3	5	5	6	6
T	3	5	5	6	6
TP	M3 Depth 8	M4 Depth 15	M4 Depth 15	M6 Depth 20	M6 Depth 20

Note: 1. Servo motor model name: ② = encoder type

ECM-B3 Series Servo Motor Specifications

220 V & 400 V Dimensions of Motors with Frame Size of 100 mm

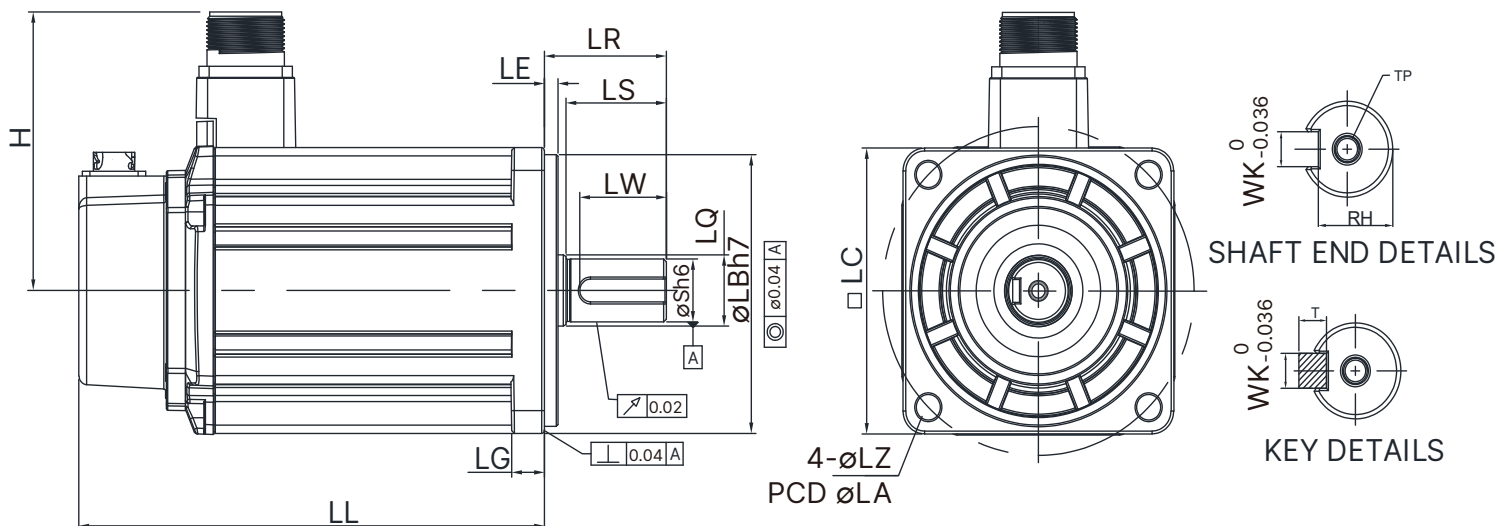

Model	B3M-C ② 1010	B3M-C ② 1015	B3M-C ② 1020
	B3M-J ② 1010	B3M-J ② 1015	B3M-J ② 1020
LC	100	100	100
LZ	9	9	9
LA	115	115	115
S	22 ^(+0/-0.013)	22 ^(+0/-0.013)	22 ^(+0/-0.013)
LB	95 ^(+0/-0.03)	95 ^(+0/-0.03)	95 ^(+0/-0.03)
LL (w/o brake)	141.8	156.8	171.8
LL (with brake)	179.9	194.9	209.9
H	97.4	97.4	97.4
LS	37	37	37
LR	45	45	45
LQ	25	25	25
LE	5	5	5
LG	12	12	12
LW	32	32	32
RH	18	18	18
WK	8	8	8
W	8	8	8
T	7	7	7
TP	M6 Depth 12	M6 Depth 12	M6 Depth 12

Note: 1. Servo motor model name: ② = encoder type
 2. The length of battery-less encoder frame LL increases as shown below

F100/F130/F180
+6.5 mm

ECM-B3 Series Servo Motor Specifications

220 V & 400 V Dimensions of Motors with Frame Size of 130 mm

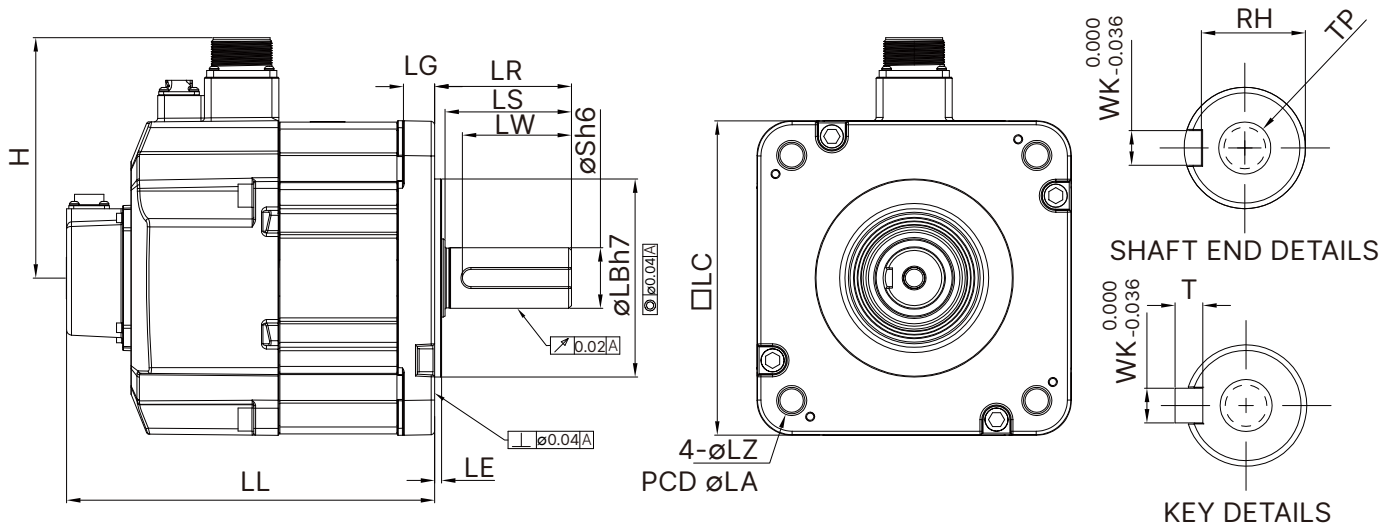

Model	B3M-E ② 1310	B3M-E ② 1315	B3M-E ② 1320	B3M-F ② 1308	B3M-F ② 1313	B3M-F ② 1318
	B3M-K ② 1310	B3M-K ② 1315	B3M-K ② 1320	B3M-K ② 1308	B3M-K ② 1313	B3M-K ② 1318
LC	130	130	130	130	130	130
LZ	9	9	9	9	9	9
LA	145	145	145	145	145	145
S	22($\begin{smallmatrix} +0 \\ -0.013 \end{smallmatrix}$)	22($\begin{smallmatrix} +0 \\ -0.013 \end{smallmatrix}$)	22($\begin{smallmatrix} +0 \\ -0.013 \end{smallmatrix}$)	22($\begin{smallmatrix} +0 \\ -0.013 \end{smallmatrix}$)	22($\begin{smallmatrix} +0 \\ -0.013 \end{smallmatrix}$)	22($\begin{smallmatrix} +0 \\ -0.013 \end{smallmatrix}$)
LB	110($\begin{smallmatrix} +0 \\ -0.035 \end{smallmatrix}$)	110($\begin{smallmatrix} +0 \\ -0.035 \end{smallmatrix}$)	110($\begin{smallmatrix} +0 \\ -0.035 \end{smallmatrix}$)	110($\begin{smallmatrix} +0 \\ -0.035 \end{smallmatrix}$)	110($\begin{smallmatrix} +0 \\ -0.035 \end{smallmatrix}$)	110($\begin{smallmatrix} +0 \\ -0.035 \end{smallmatrix}$)
LL (w/o brake)	127.9	139.9	151.9	127.9	139.9	151.9
LL (with brake)	168.5	180.5	192.5	168.5	180.5	192.5
H	115	115	115	115	115	115
LS	47	47	47	47	47	47
LR	55	55	55	55	55	55
LQ	28	28	28	28	28	28
LE	6	6	6	6	6	6
LG	12.5	12.5	12.5	12.5	12.5	12.5
LW	36	36	36	36	36	36
RH	18	18	18	18	18	18
WK	8	8	8	8	8	8
W	8	8	8	8	8	8
T	7	7	7	7	7	7
TP	M6 Depth 12	M6 Depth 12	M6 Depth 12	M6 Depth 12	M6 Depth 12	M6 Depth 12

Note: 1. Servo motor model name: ② = encoder type
 2. The length of battery-less encoder frame LL increases as shown below (except for 7.5 kW)

F100/F130/F180 +6.5mm

ECM-B3 Series Servo Motor Specifications

220 V & 400 V Dimensions of Motors with Frame Size of 180 mm

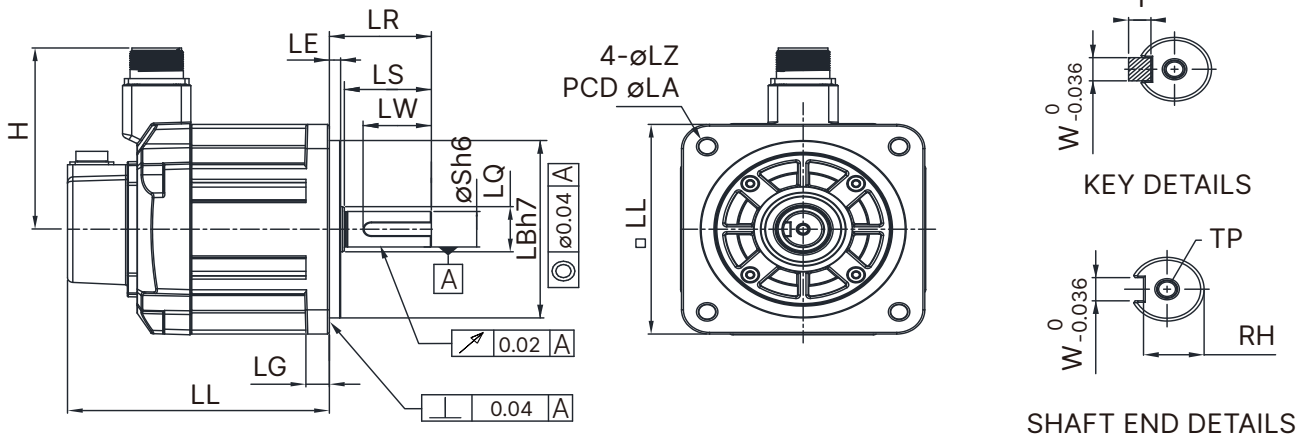

Model	B3M-E ② 1820	B3M-F ② 1830	B3M-L ② 1845
	B3M-K ② 1820	B3M-L ② 1830	
LC	180	180	180
LZ	13.5	13.5	13.5
LA	200	200	200
S	35($^{+0}_{-0.016}$)	35($^{+0}_{-0.016}$)	35($^{+0}_{-0.016}$)
LB	114.3($^{+0}_{-0.035}$)	114.3($^{+0}_{-0.035}$)	114.3($^{+0}_{-0.035}$)
LL (w/o brake)	137.5	160.5	174
LL (with brake)	189.5	212.5	226
H	139	139	139
LS	73	73	73
LR	79	79	79
LQ	45	45	45
LE	4	4	4
LG	18	18	18
LW	63	63	63
RH	30	30	30
WK	10	10	10
W	10	10	10
T	8	8	8
TP	M12 Depth 25	M12 Depth 25	M12 Depth 25

Note: 1. Servo motor model name: ② = encoder type
 2. The length of battery-less encoder frame LL increases as shown below (except for 7.5 kW)

F100/F130/F180
+6.5 mm

ECM-B3 Series Servo Motor Specifications

220 V Dimensions of Motors with Frame Size of 180 mm

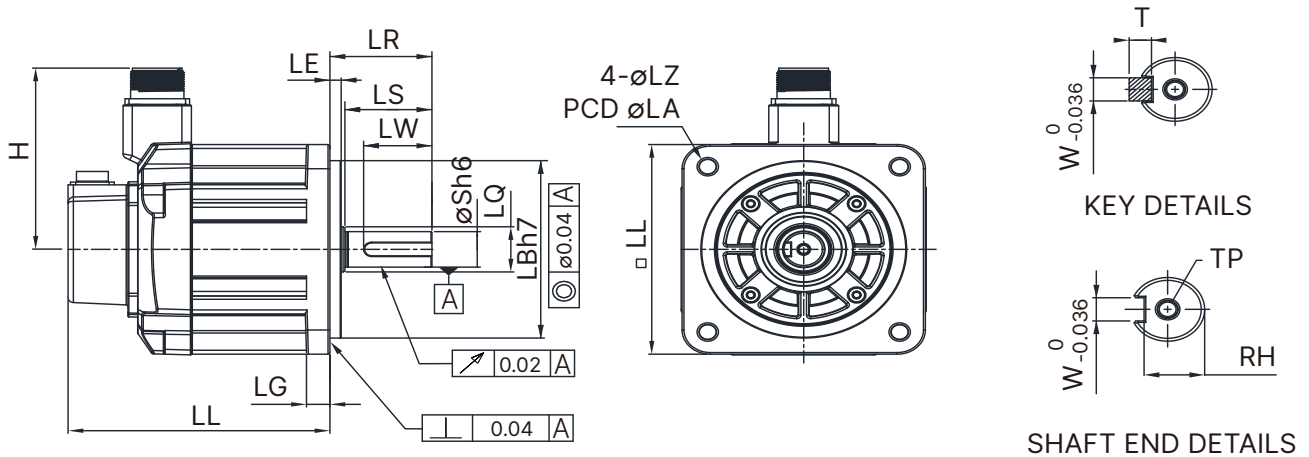

Model	B3M-L ② 1855	B3M-L ② 1875
LC	180	180
LZ	13.5	13.5
LA	200	200
S	42($^{+0}_{-0.016}$)	42($^{+0}_{-0.016}$)
LB	114.3($^{+0}_{-0.035}$)	114.3($^{+0}_{-0.035}$)
LL (w/o brake)	218	260.1
LL (with brake)	265	307.1
H	144.5	144.5
LS	108.5	108.5
LR	113	113
LQ	45	45
LE	4	4
LG	18	18
LW	90	90
RH	37	37
WK	12	12
W	12	12
T	8	8
TP	M16 Depth 32	M16 Depth 32

Note: 1. Servo motor model name: ② = encoder type
 2. The length of battery-less encoder frame LL increases as shown below (except for 7.5 kW)

F100/F130/F180
+6.5 mm

ECM-A3 Series Servo Motor Specifications

Electrical Specifications

Low Inertia Motor ECM-A3L Series

	ECM-A3L-C ₂ 040F ^{*1}	ECM-A3L-C ₂ 0401 ^{*1}	ECM-A3L-C ₂ 0602 ^{*1}
Rated Power (kW)	0.05	0.1	0.2
Rated Torque (N-m) ^{*2}	0.159	0.32	0.64
Maximum Torque (N-m)	0.557	1.12	2.24
Rated Speed (rpm)	3,000		
Maximum Speed (rpm)	6,000		
Rated Current (Arms)	0.66	0.9	1.45
Max. Instantaneous Current (Arms)	2.82	3.88	6.2
Rated Power Rate (kW/s) ^{*3}	11 (9.9)	25.6 (24)	45.5 (34.1)
Rotor Inertia ($\times 10^{-4}$ kg.m ²) ^{*3}	0.0229 (0.0255)	0.04 (0.0426)	0.09 (0.12)
Mechanical Time Constant (ms) ^{*3}	1.28 (1.44)	0.838 (0.892)	0.64 (0.85)
Torque Constant -KT (N-m/A)	0.241	0.356	0.441
Voltage Constant -KE (mV/(rpm))	9.28	13.3	16.4
Armature Resistance (Ohm)	12.1	9.47	4.9
Armature Inductance (mH)	18.6	16.2	18.52
Electrical Time Constant (ms)	1.54	1.71	3.78
Brake Holding Torque [Nt-m (min)] ^{*4}	0.32	0.32	1.3
Brake Power Consumption (at 20°C)[W]	6.1	6.1	7.2
Brake Release Time [ms (Max.)]	20	20	20
Brake Pull-In Time [ms (Max.)]	35	35	50
Max. Radial Loading (N) ^{*5}	78	78	245
Max. Axial Loading (N) ^{*5}	54	54	74
Weight (kg) ^{*3}	0.38 (0.68)	0.5 (0.8)	1.1 (1.6)
Derating (%) (with oil seal)	20	10	10

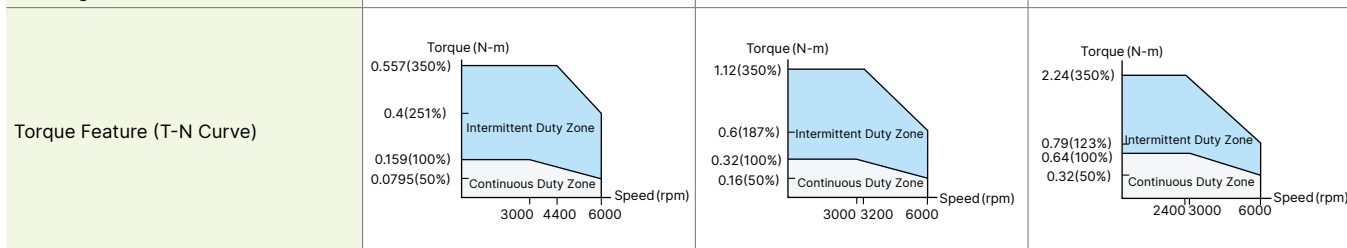

Insulation Class	Class A (UL), Class B (CE)
Insulation Resistance	> 100 MΩ, DC 500 V
Insulation Strength	2.3 k Vac, 1 sec
Vibration Level (μm)	V15
Operating Temperature	0°C ~ 40°C
Storage Temperature	-10°C ~ 80°C
Storage & Operation Humidity	20 ~ 90% RH (non-condensing)
Vibration Capacity	2.5 G
IP Rating	IP67 (when using waterproof connections and when an oil seal is fitted to the rotating shaft (for an oil seal model))
Certifications	

Notes:
 1. In the servo motor model name, 2 represents the encoder type.
 2. The rated torque is the continuous permissible torque between 0 to 40°C operating temperature which is suitable for the servo motor mounted with the following heat sink dimensions.
 F130: 400 mm x 400 mm x 20 mm
 Material: aluminum
 3. The built-in servo motor brake is only for keeping the object in a stopped state.
 4. If the operating temperature is over 40°C, refer to the power derating curves of B3 motors on page 37.

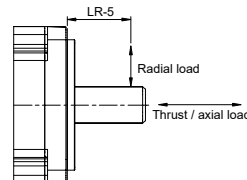

5. Please follow the max. tolerant loading of the motor shaft end listed below during operation



ECM-A3 Series Servo Motor Specifications

Electrical Specifications

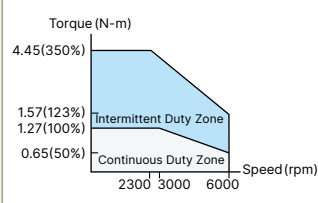
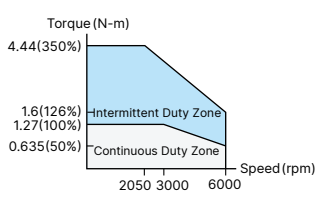
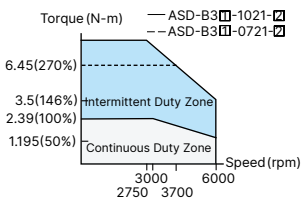
Low Inertia Motor ECM-A3L Series

	ECM-A3L-C 0604*1	ECM-A3L-C 0804*1	ECM-A3L-C 0807*1
Rated Power (kW)	0.4	0.4	0.75
Rated Torque (N-m) ^{*2}	1.27	1.27	2.39
Maximum Torque (N-m)	4.45	4.44	8.36
Rated Speed (rpm)	3,000		
Maximum Speed (rpm)	6,000		
Rated Current (Arms)	2.65	2.6	5.1
Max. Instantaneous Current (Arms)	10.1	10.6	20.6
Rated Power Rate (kW/s) ^{*3}	107.5 (89.6)	45.8 (39.5)	102.2 (93)
Rotor Inertia ($\times 10^{-4}$ kg.m ²) ^{*3}	0.15 (0.18)	0.352 (0.408)	0.559 (0.614)
Mechanical Time Constant (ms) ^{*3}	0.41 (0.5)	0.68 (0.78)	0.44 (0.48)
Torque Constant -KT (N-m/A)	0.479	0.488	0.469
Voltage Constant -KE (mV/(rpm))	18	17.9	17
Armature Resistance (Ohm)	2.27	1.6	0.6
Armature Inductance (mH)	10.27	10.6	4.6
Electrical Time Constant (ms)	4.52	6.63	7.67
Brake Holding Torque [Nt-m (min)] ^{*4}	1.3	2.5	2.5
Brake Power Consumption (at 20°C)[W]	7.2	8	8
Brake Release Time [ms (Max.)]	20	20	20
Brake Pull-In Time [ms (Max.)]	50	60	60
Max. Radial Loading (N) ^{*5}	245	392	392
Max. Axial Loading (N) ^{*5}	74	147	147
Weight (kg) ^{*3}	1.4 (1.9)	2.05 (2.85)	2.8 (3.6)
Derating (%) (with oil seal)	5	5	5
Torque Feature (T-N Curve)			
Insulation Class	Class A (UL), Class B (CE)		
Insulation Resistance	> 100 MΩ, DC 500 V		
Insulation Strength	1.8k V _{AC} , 1 sec		
Vibration Level (μm)	V15		
Operating Temperature	0°C ~ 40°C		
Storage Temperature	-10°C ~ 80°C		
Storage & Operation Humidity	20 ~ 90% RH (non-condensing)		
Vibration Capacity	2.5 G		
IP Rating	IP67 (when using waterproof connections and when an oil seal is fitted to the rotating shaft (for an oil seal model))		
Certifications			

Notes:

- In the servo motor model name, 1 represents the motor inertia and 2 represents the encoder type.
- The rated torque is the continuous permissible torque between 0 to 40°C operating temperature which is suitable for the servo motor mounted with the following heat sink dimensions.
F40, F60, F80: 250 mm x 250 mm x 6 mm
Material: aluminum
- (.) = motor with brake
- The built-in servo motor brake is only for keeping the object in a stopped state. Do not use it for deceleration or as a dynamic brake.

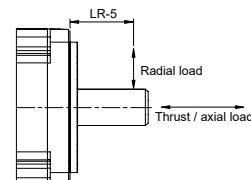

- Please follow the max. tolerating loading of the motor shaft end listed below during operation



ECM-A3 Series Servo Motor Specifications

Electrical Specifications

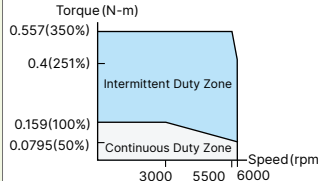
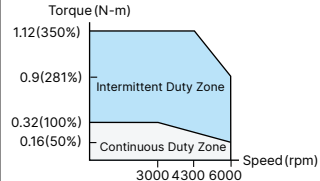
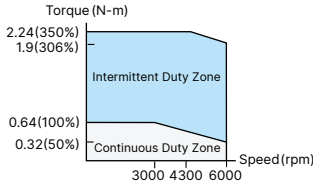
ECM-A3H High Inertia Series Servo Motor

	ECM-A3H-C 040F ^{*1}	ECM-A3H-C 0401 ^{*1}	ECM-A3H-C 0602 ^{*1}
Rated Power (kW)	0.05	0.1	0.2
Rated Torque (N-m) ^{*2}	0.159	0.32	0.64
Maximum Torque (N-m)	0.557	1.12	2.24
Rated Speed (rpm)	3,000		
Maximum Speed (rpm)	6,000		
Rated Current (Arms)	0.64	0.9	1.45
Max. Instantaneous Current (Arms)	2.59	3.64	5.3
Rated Power Rate (kW/s) ^{*3}	5.56 (4.89)	13.6 (12.5)	16.4 (14.6)
Rotor Inertia ($\times 10^{-4}$ kg.m ²) ^{*3}	0.0455 (0.0517)	0.0754 (0.0816)	0.25 (0.28)
Mechanical Time Constant (ms) ^{*3}	2.52 (2.86)	1.43 (1.55)	1.38 (1.54)
Torque Constant -KT (N-m/A)	0.248	0.356	0.441
Voltage Constant -KE (mV/(rpm))	9.54	12.9	16.4
Armature Resistance (Ohm)	12.5	8.34	3.8
Armature Inductance (mH)	13.34	11	8.15
Electrical Time Constant (ms)	1.07	1.32	2.14
Brake Holding Torque [Nt-m (min)] ^{*4}	0.32	0.32	1.3
Brake Power Consumption (at 20°C)[W]	6.1	6.1	7.2
Brake Release Time [ms (Max.)]	20	20	20
Brake Pull-In Time [ms (Max.)]	35	35	50
Max. Radial Loading (N) ^{*5}	78	78	245
Max. Axial Loading (N) ^{*5}	54	54	74
Weight (kg) ^{*3}	0.38 (0.68)	0.5 (0.8)	1.1 (1.6)
Derating (%) (with oil seal)	20	10	10
Torque Feature (T-N Curve)			
Insulation Class	Class A (UL), Class B (CE)		
Insulation Resistance	> 100 MΩ, DC 500 V		
Insulation Strength	1.8k V _{AC} , 1 sec		
Vibration Level (μm)	V15		
Operating Temperature	0°C ~ 40°C		
Storage Temperature	-10°C ~ 80°C		
Storage & Operation Humidity	20 ~ 90% RH (non-condensing)		
Vibration Capacity	2.5 G		
IP Rating	IP67 (when using waterproof connections and when an oil seal is fitted to the rotating shaft (for an oil seal model))		
Certifications			

Notes:

- In the servo motor model name, 1 represents the motor inertia and 2 represents the encoder type.
- The rated torque is the continuous permissible torque between 0 to 40°C operating temperature which is suitable for the servo motor mounted with the following heat sink dimensions.
F40, F60, F80: 250 mm x 250 mm x 6 mm
Material: aluminum
- () = motor with brake
- The built-in servo motor brake is only for keeping the object in a stopped state. Do not use it for deceleration or as a dynamic brake.

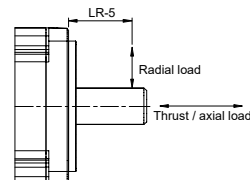

- Please follow the max. tolerant loading of the motor shaft end listed below during operation



ECM-A3 Series Servo Motor Specifications

Electrical Specifications

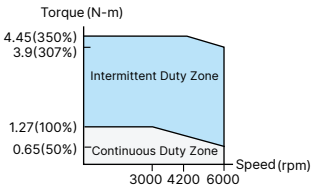
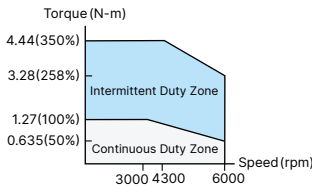
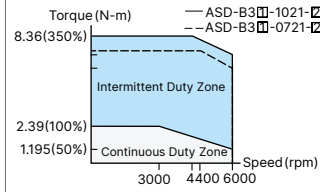
High Inertia Motor ECM-A3H Series

	ECM-A3H-C ² 0604 ¹	ECM-A3H-C ² 0804 ¹	ECM-A3H-C ² 0807 ¹
Rated Power (kW)	0.4	0.4	0.75
Rated Torque (N-m) ^{*2}	1.27	1.27	2.39
Maximum Torque (N-m)	4.45	4.44	8.36
Rated Speed (rpm)			
Maximum Speed (rpm)			
Rated Current (Arms)	2.65	2.6	4.61
Max. Instantaneous Current (Arms)	9.8	9.32	16.4
Rated Power Rate (kW/s) ^{*3}	35.8 (33.6)	17.5 (15.07)	37.8 (34.41)
Rotor Inertia ($\times 10^{-4}$ kg.m ²) ^{*3}	0.45 (0.48)	0.92 (1.07)	1.51 (1.66)
Mechanical Time Constant (ms) ^{*3}	0.96 (1.02)	1.32 (1.54)	0.93 (1.02)
Torque Constant -KT (N-m/A)	0.479	0.49	0.52
Voltage Constant -KE (mV/(rpm))	17.2	17.9	18.7
Armature Resistance (Ohm)	1.68	1.19	0.57
Armature Inductance (mH)	4.03	4.2	2.2
Electrical Time Constant (ms)	2.40	3.53	3.86
Brake Holding Torque [Nt-m (min)] ^{*4}	1.3	2.5	2.5
Brake Power Consumption (at 20°C)[W]	7.2	8	8
Brake Release Time [ms (Max.)]	20	20	20
Brake Pull-In Time [ms (Max.)]	50	60	60
Max. Radial Loading (N) ^{*5}	245	392	392
Max. Axial Loading (N) ^{*5}	74	147	147
Weight (kg) ^{*3}	1.4 (1.9)	2.05 (2.85)	2.8 (3.6)
Derating (%) (with oil seal)	5	5	5
Torque Feature (T-N Curve)			
Insulation Class	Class A (UL), Class B (CE)		
Insulation Resistance	> 100 MΩ, DC 500 V		
Insulation Strength	1.8k Vac, 1 sec		
Vibration Level (μm)	V15		
Operating Temperature	0°C ~ 40°C		
Storage Temperature	-10°C ~ 80°C		
Storage & Operation Humidity	20 - 90%RH (non-condensing)		
Vibration Capacity	2.5 G		
IP Rating	IP67 (when using waterproof connections and when an oil seal is fitted to the rotating shaft (for an oil seal model))		
Certifications			

Notes:

- In the servo motor model name, 1 represents the motor inertia and 2 represents the encoder type.
- The rated torque is the continuous permissible torque between 0 to 40°C operating temperature which is suitable for the servo motor mounted with the following heat sink dimensions.
F40, F60, F80: 250 mm x 250 mm x 6 mm
Material: aluminum
- (.) = motor with brake
- The built-in servo motor brake is only for keeping the object in a stopped state. Do not use it for deceleration or as a dynamic brake.

- Please follow the max. tolerating loading of the motor shaft end listed below during operation

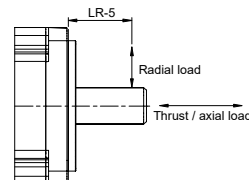

ECM-A3 Series Servo Motor Specifications

Dimensions of Motors with Frame Size of 80 mm or Below

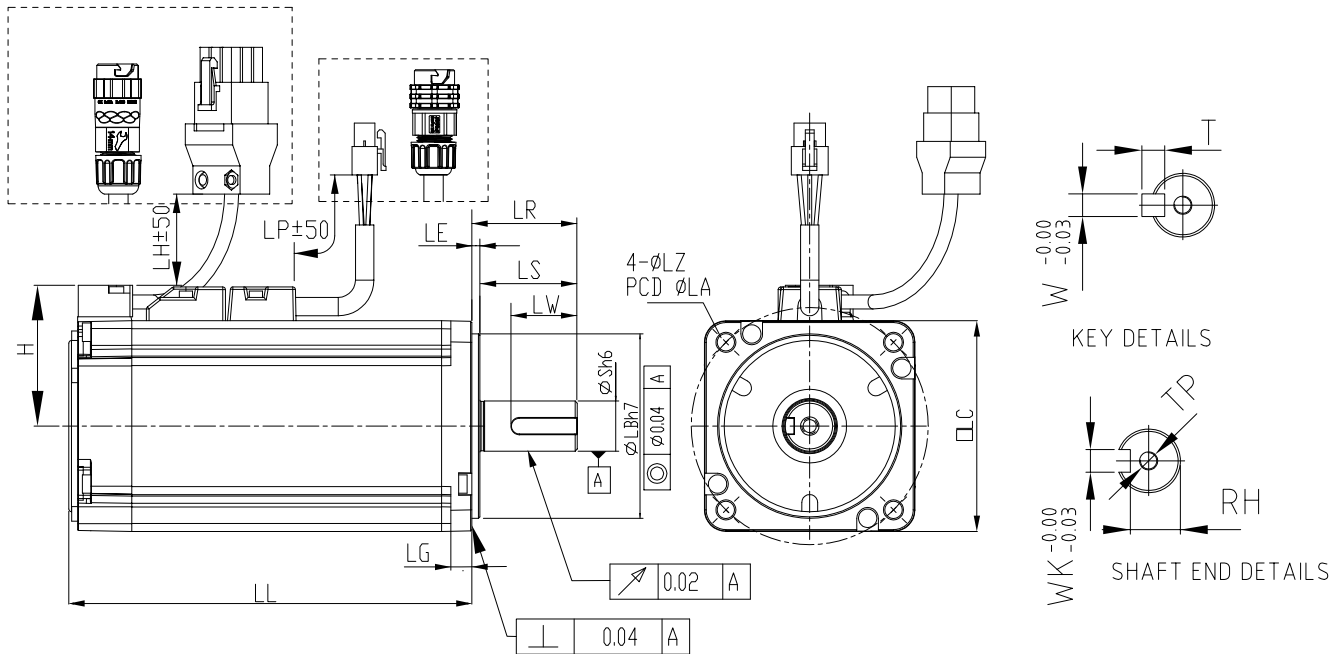

Model	C 2 040F 3 4 5	C 2 0401 3 4 5	C 2 0602 3 4 5	C 2 0604 3 4 5	C 2 0804 3 4 5	C 2 0807 3 4 5
LC	40	40	60	60	80	80
LZ	4.5	4.5	5.5	5.5	6.6	6.6
LA	46	46	70	70	90	90
S	8 ^(+0/-0.009)	8 ^(+0/-0.009)	14 ^(+0/-0.011)	14 ^(+0/-0.011)	14 ^(+0/-0.011)	19 ^(+0/-0.013)
LB	30 ^(+0/-0.021)	30 ^(+0/-0.021)	50 ^(+0/-0.025)	50 ^(+0/-0.025)	70 ^(+0/-0.030)	70 ^(+0/-0.030)
LL (w/o brake)	70.6	85.3	84	106	93.7	115.8
LL (with brake)	105.4	120.1	117.6	139.7	131.2	153.2
LH	300	300	300	300	300	300
LP	300	300	300	300	300	300
H	34	34	43.5	43.5	54.5	54.5
LS	21.5	21.5	27	27	27	37
LR	25	25	30	30	30	40
LE	2.5	2.5	3	3	3	3
LG	5	5	7.5	7.5	8	8
LW	16	16	20	20	20	25
RH	6.2	6.2	11	11	11	15.5
WK	3	3	5	5	5	6
W	3	3	5	5	5	6
T	3	3	5	5	5	6
TP	M3 Depth 6	M3 Depth 6	M4 Depth 8	M4 Depth 8	M4 Depth 8	M6 Depth 10

Notes:

- In the servo motor model name, 2 represents the encoder type, 3 represents the brake or keyway / oil seal type, 4 represents the shaft diameter and connector type, and 5 represents the special code.
- When the special code of the C2 0807 3 4 5 model is Z, then its LS = 32 and LR = 35.
- When the 4 in the motor model name is J or K, the connector is an IP67 waterproof connector.

Control Mode Wiring

Position (PT) Mode Standard Wiring (Differential Pulse Signals)

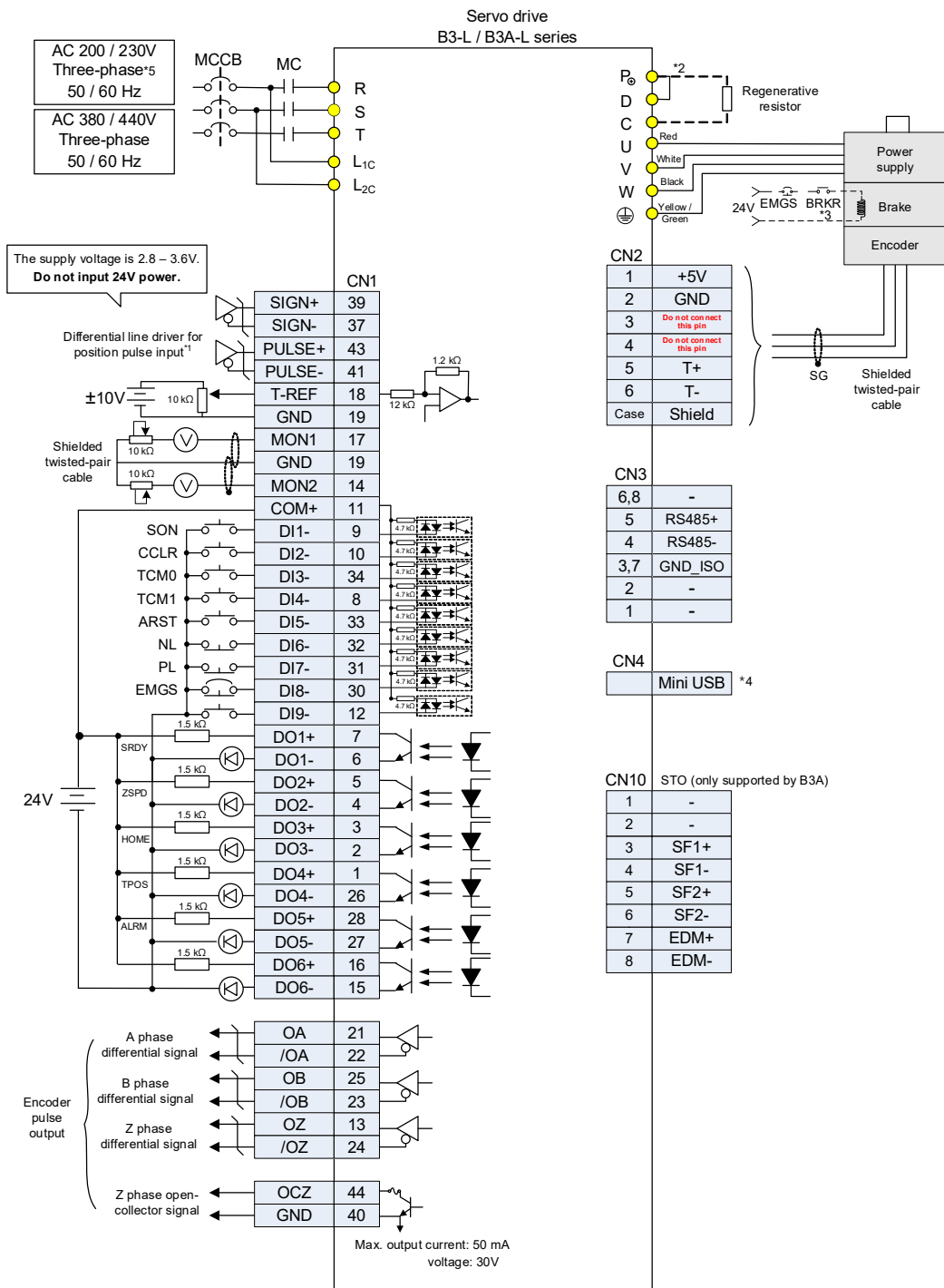

Notes:

- *1: Refer to Section 3.3.7 in the ASDA-B3 user manual for CN1 wiring
- *2: Models of 200 W and below have no built-in brake resistor
- *3: The brake coil has no polarity
- *4: Connects to Mini USB (for PC communication)
- *5: Models of 1.5 kW and below can use single-phase power supply

Control Mode Wiring

Position (PT) Control Mode (Open-Collector Pulse Signals)

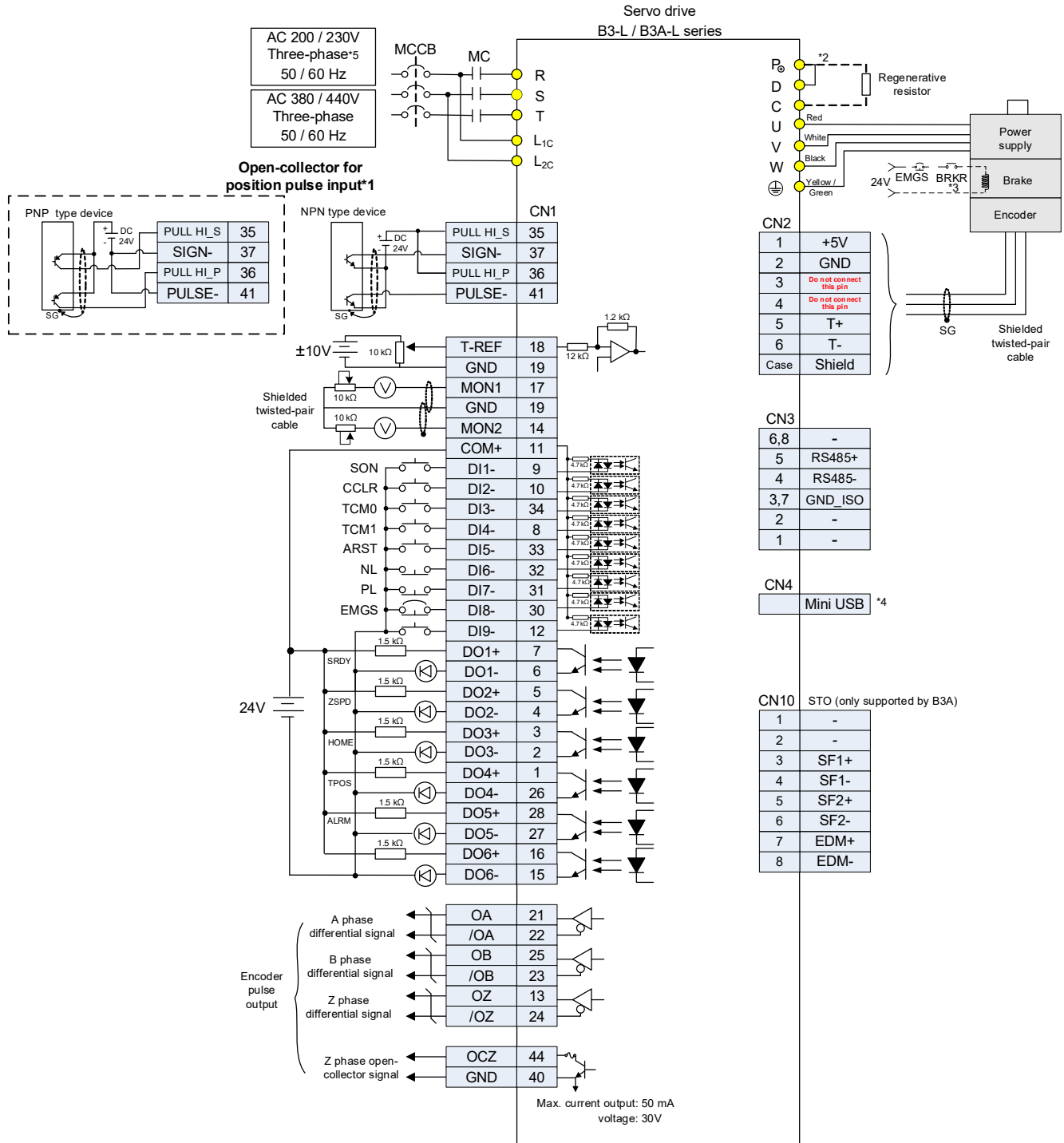

Notes:

- *1: Refer to Section 3.3.7 in the ASDA-B3 user manual for CN1 wiring
- *2: Models of 200 W and below have no built-in brake resistor
- *3: The brake coil has no polarity
- *4: Connects to Mini USB (for PC communication)
- *5: Models of 1.5 kW and below can use single-phase power supply

Control Mode Wiring

Position (PR) Mode Standard Wiring (Internal Position Commands)

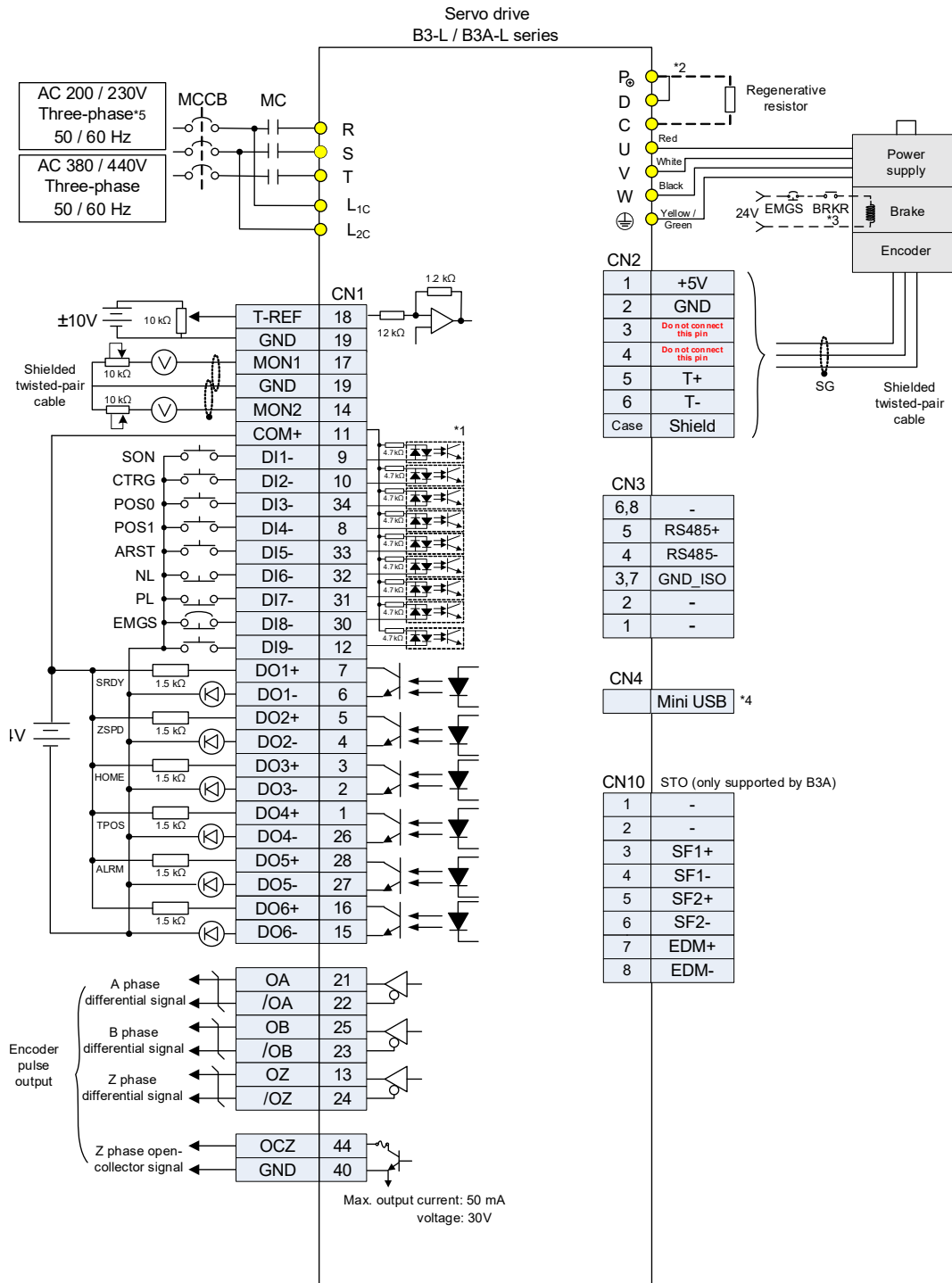

Notes:

- *1: Refer to Section 3.3.7 in the ASDA-B3 user manual for CN1 wiring
- *2: Models of 200 W and below have no built-in brake resistor
- *3: The brake coil has no polarity
- *4: Connects to Mini USB (for PC communication)
- *5: Models of 1.5 kW and below can use single-phase power supply

Control Mode Wiring

Torque (T) Mode Standard Wiring

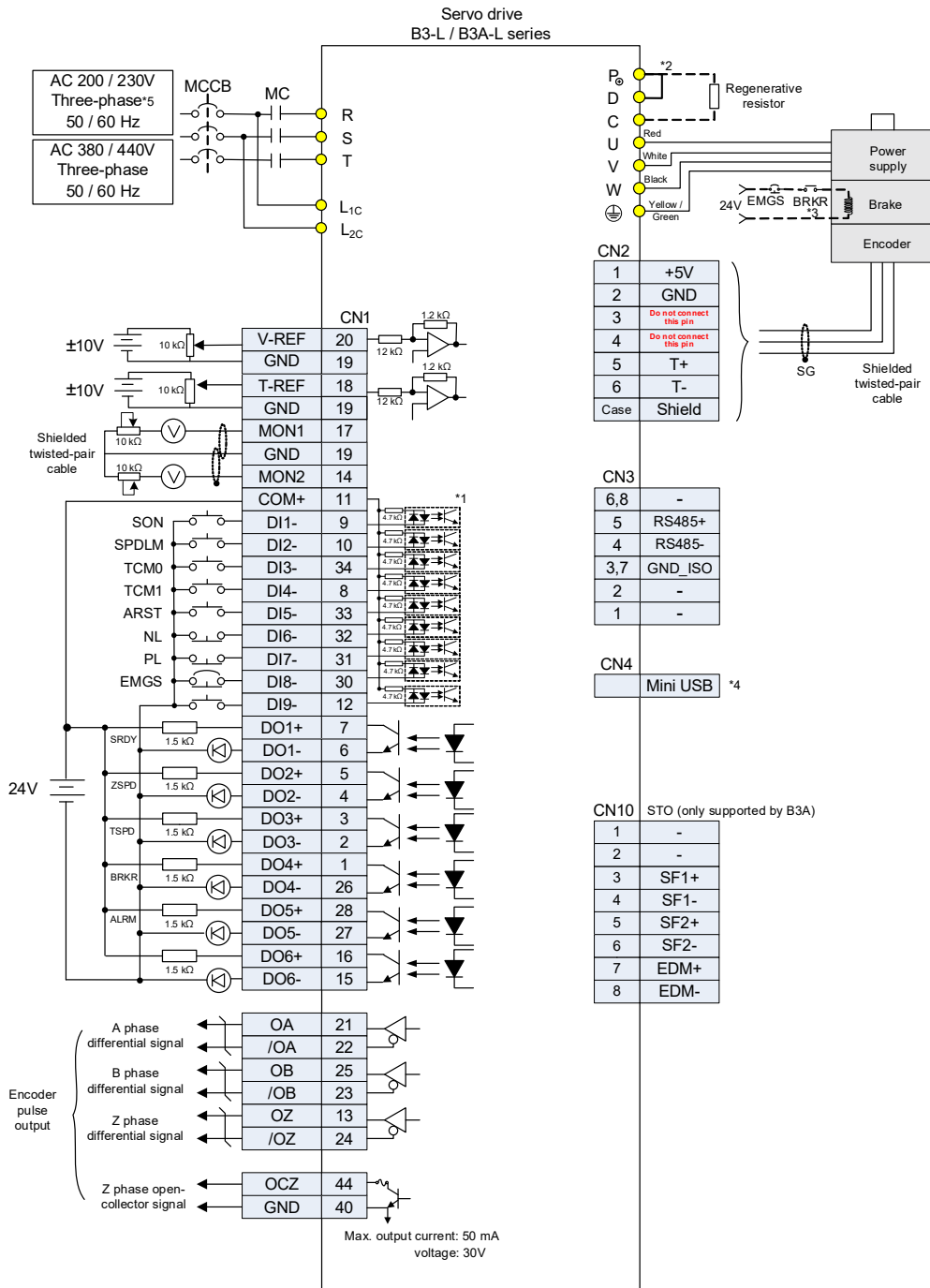

- Notes:
 *1: Refer to Section 3.3.7 in the ASDA-B3 user manual for CN1 wiring
 *2: Models of 200 W and below have no built-in brake resistor
 *3: The brake coil has no polarity
 *4: Connects to Mini USB (for PC communication)
 *5: Models of 1.5 kW and below can use single-phase power supply

Control Mode Wiring

Speed (S) Mode Standard Wiring

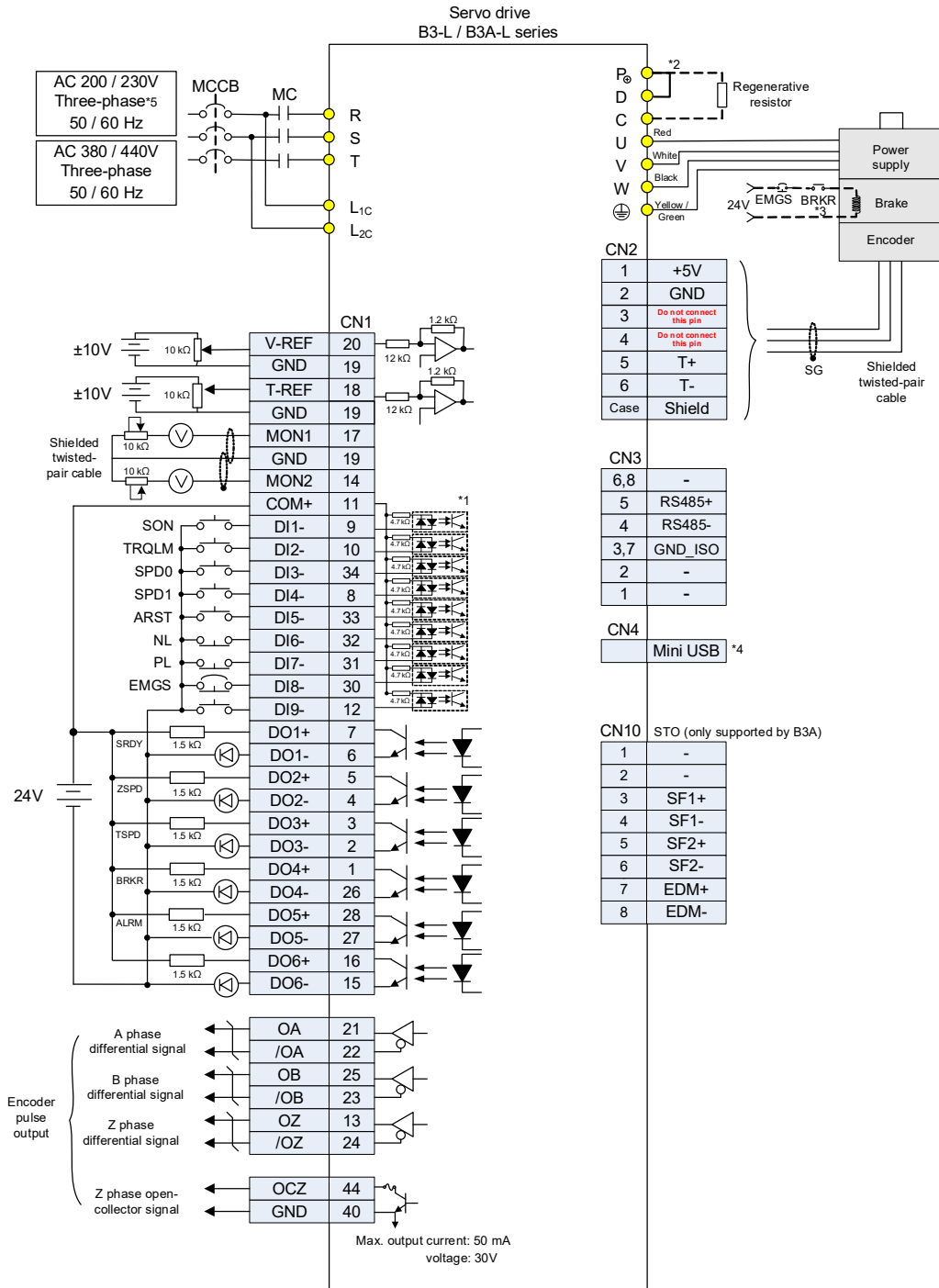

Notes:

- *1: Refer to Section 3.3.7 in the ASDA-B3 user manual for CN1 wiring
- *2: Models of 200 W and below have no built-in brake resistor
- *3: The brake coil has no polarity
- *4: Connects to Mini USB (for PC communication)
- *5: Models of 1.5 kW and below can use single-phase power supply

Control Mode Wiring

CANopen Communication Mode Standard Wiring

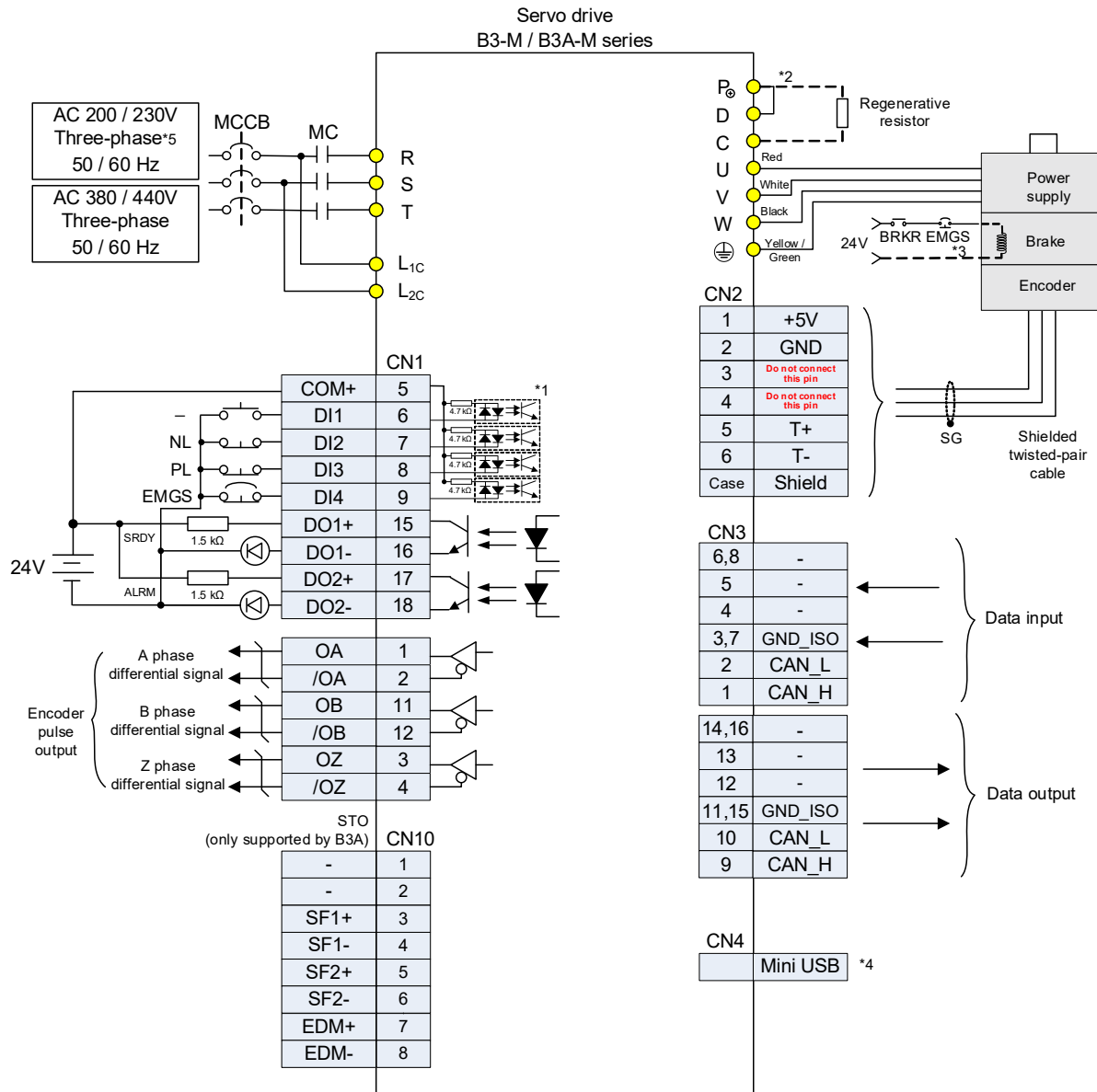

Notes:

- *1: Refer to Section 3.3.7 in the ASDA-B3 user manual for CN1 wiring
- *2: Models of 200 W and below have no built-in brake resistor
- *3: The brake coil has no polarity
- *4: Connects to Mini USB (for PC communication)
- *5: Models of 1.5 kW and below can use single-phase power supply

Control Mode Wiring

DMCNET Communication Mode Standard Wiring

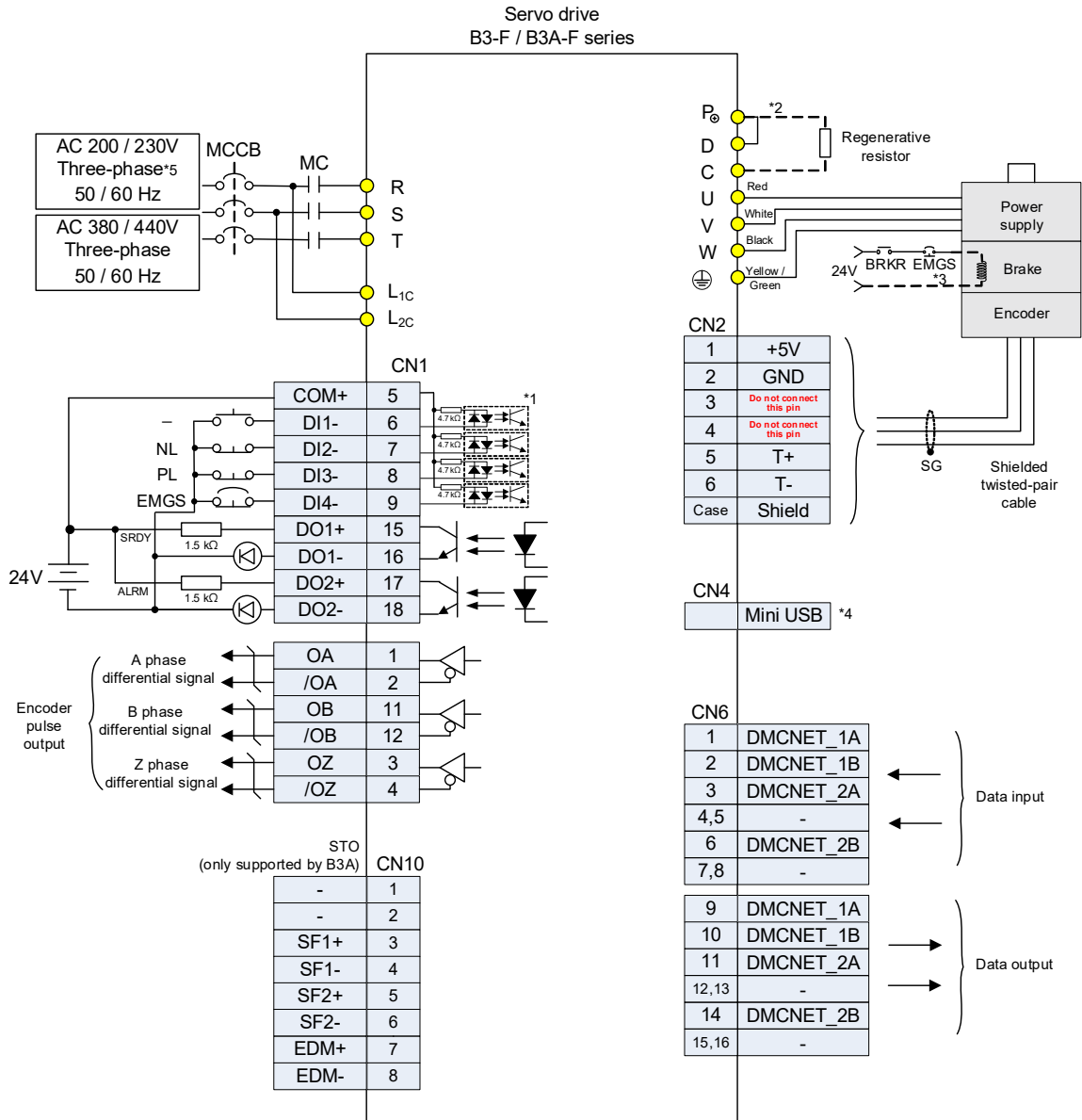

Notes:

- *1: Refer to Section 3.3.7 in the ASDA-B3 user manual for CN1 wiring
- *2: Models of 200 W and below have no built-in brake resistor
- *3: The brake coil has no polarity
- *4: Connects to Mini USB (for PC communication)
- *5: Models of 1.5 kW and below can use single-phase power supply

Control Mode Wiring

EtherCAT Communication Mode Standard Wiring

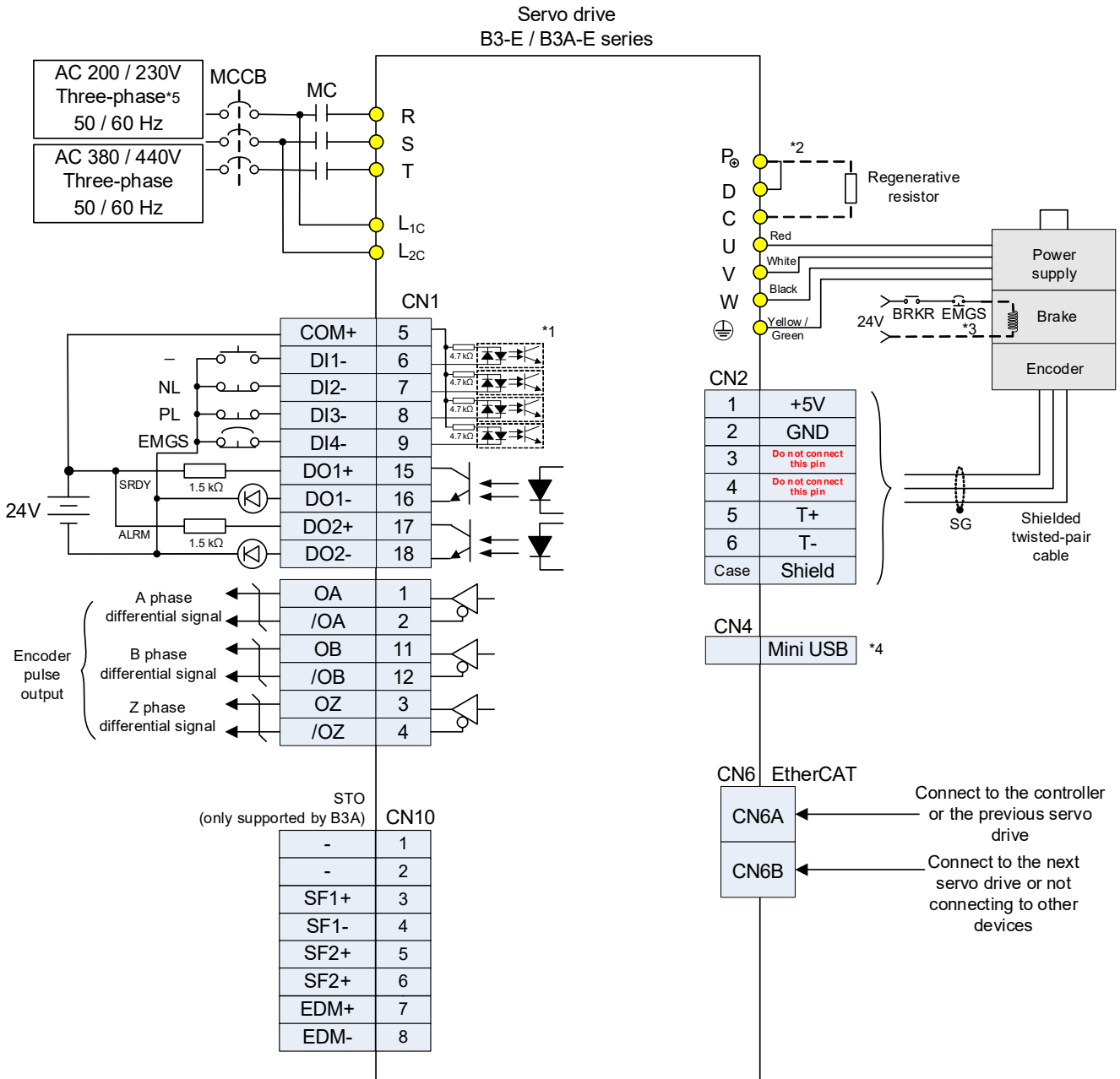

Notes:

- *1: Refer to Section 3.3.7 in the ASDA-B3 user manual for CN1 wiring
- *2: Models of 200 W and below have no built-in brake resistor
- *3: The brake coil has no polarity
- *4: Connects to Mini USB (for PC communication)
- *5: Models of 1.5 kW and below can use single-phase power supply

Control Mode Wiring

PROFINET Communication Mode Standard Wiring

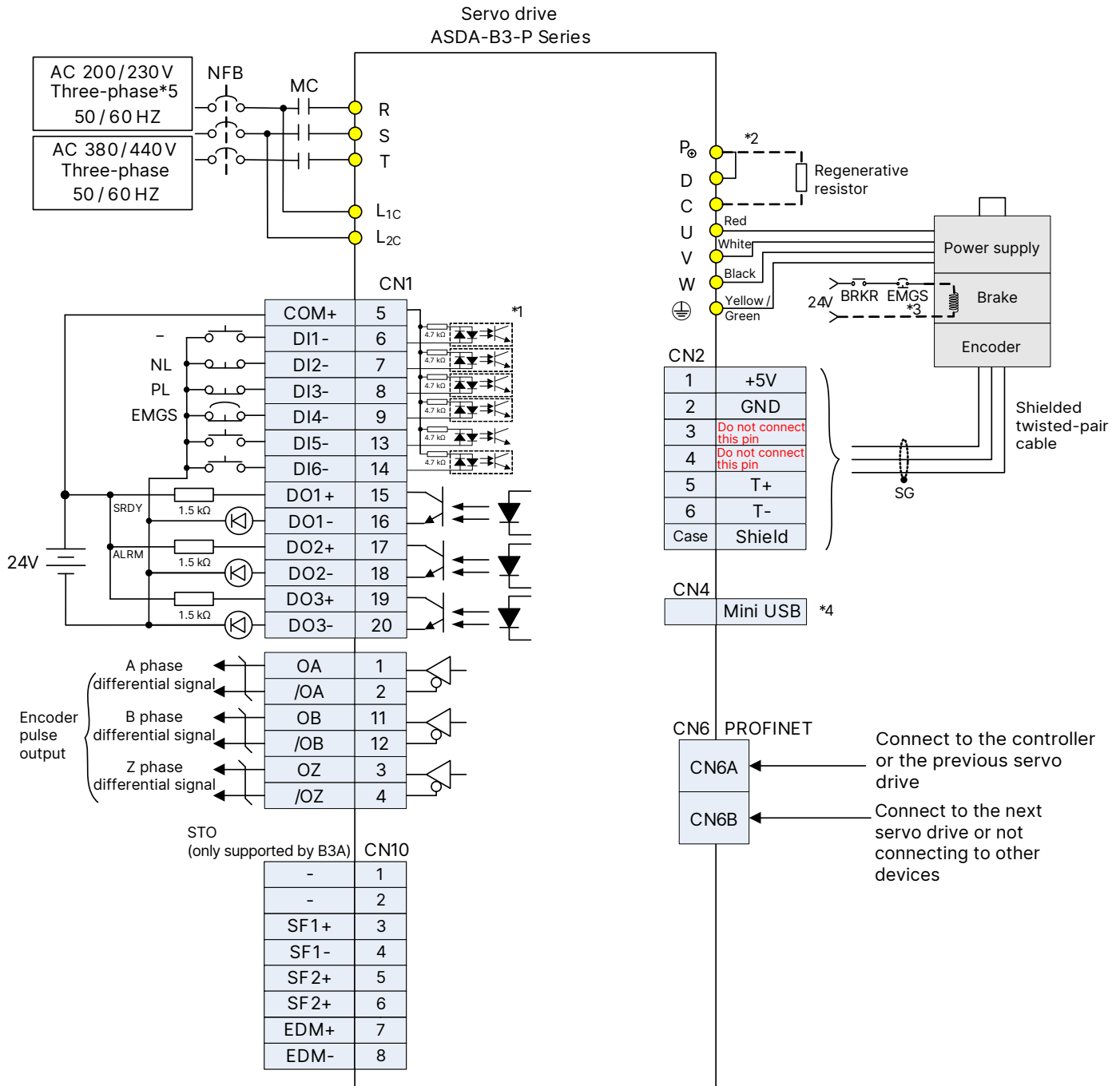

Notes:

- *1: Refer to Section 3.3.7 in the ASDA-B3 user manual for CN1 wiring
- *2: Models of 200 W and below have no built-in brake resistor
- *3: The brake coil has no polarity
- *4: Connects to Mini USB (for PC communication)
- *5: Models of 1.5 kW and below can use single-phase power supply

Ordering Information

Accessories

Built-in Motor with Frame Size of 80 mm or Below

Power Connectors

ACS3-AFPWSS00

With or w/o brake
Cable exit direction towards motor shaft

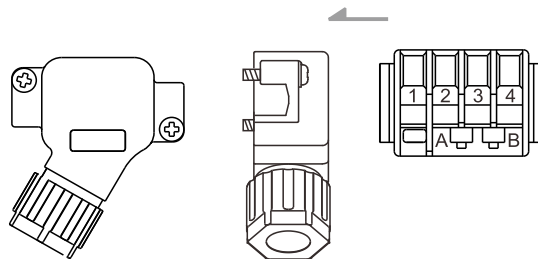

ACS3-ABPWSS00

With or w/o brake
Cable exit direction towards encoder

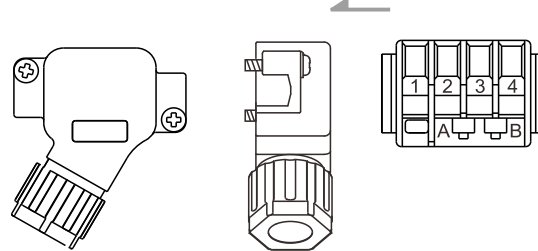

Encoder Connectors

ACS3-AFEASA00

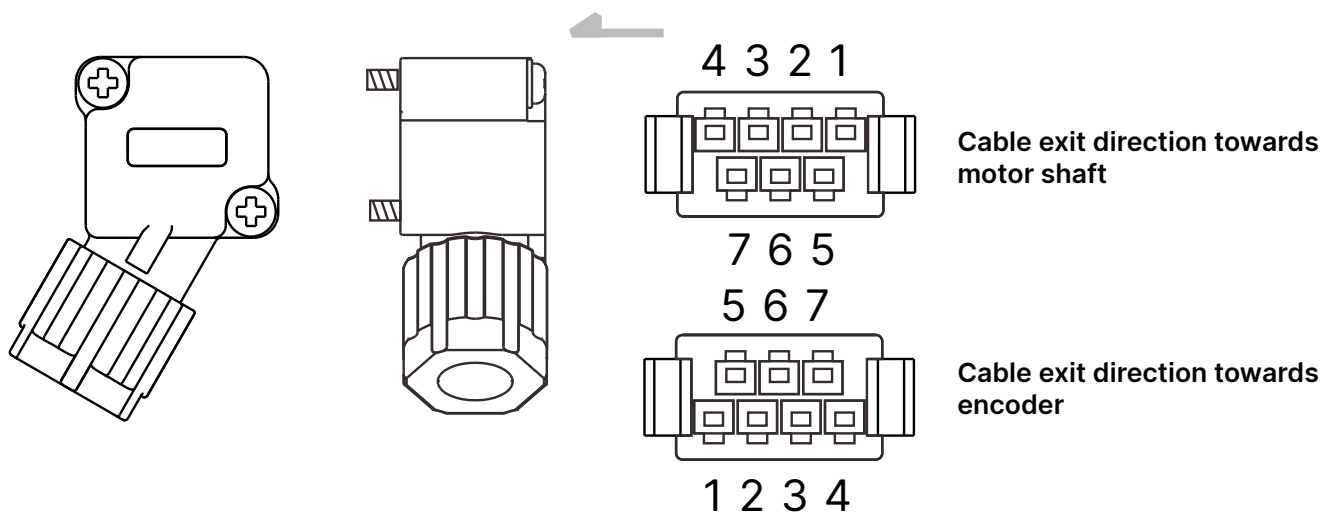

Ordering Information

Accessories

200 V Built-in Motor with Frame Size of 80 mm or Below

Power Connectors

Without brake - cable exit direction towards motor shaft

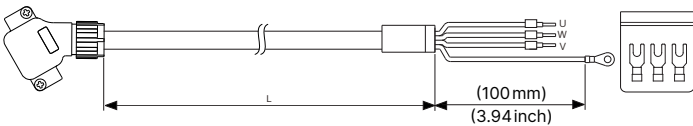

Cable	Model Name	UVW	L	
		AWG (mm ²)	mm	inch
Standard	ACS3-AFPWSR03	20 (0.5)	3,000 ± 50	118 ± 2
	ACS3-AFPWSR05	20 (0.5)	5,000 ± 50	197 ± 2
	ACS3-AFPWSR10	20 (0.5)	10,000 ± 50	394 ± 4
	ACS3-AFPWSR20	20 (0.5)	20,000 ± 50	787 ± 4
Torsion-Resistant	ACS3-AFPRSR03	20 (0.5)	3,000 ± 50	118 ± 2
	ACS3-AFPRSR05	20 (0.5)	5,000 ± 50	197 ± 2
	ACS3-AFPRSR10	20 (0.5)	10,000 ± 50	394 ± 4
	ACS3-AFPRSR20	20 (0.5)	20,000 ± 50	787 ± 4

Without brake - cable exit direction towards encoder

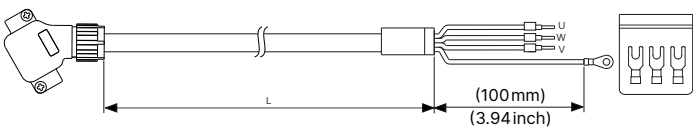

Cable	Model Name	UVW	L	
		AWG (mm ²)	mm	inch
Standard	ACS3-ABPWSR03	20 (0.5)	3,000 ± 50	118 ± 2
	ACS3-ABPWSR05	20 (0.5)	5,000 ± 50	197 ± 2
	ACS3-ABPWSR10	20 (0.5)	10,000 ± 50	394 ± 4
	ACS3-ABPWSR20	20 (0.5)	20,000 ± 50	787 ± 4
Torsion-Resistant	ACS3-ABPRSR03	20 (0.5)	3,000 ± 50	118 ± 2
	ACS3-ABPRSR05	20 (0.5)	5,000 ± 50	197 ± 2
	ACS3-ABPRSR10	20 (0.5)	10,000 ± 50	394 ± 4
	ACS3-ABPRSR20	20 (0.5)	20,000 ± 50	787 ± 4

With brake - cable exit direction towards motor shaft

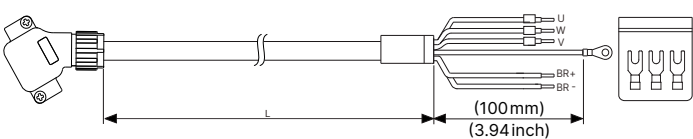

Cable	Model Name	UVW	L	
		AWG (mm ²)	mm	inch
Standard	ACS3-AFPWSS03	20 (0.5)	3,000 ± 50	118 ± 2
	ACS3-AFPWSS05	20 (0.5)	5,000 ± 50	197 ± 2
	ACS3-AFPWSS10	20 (0.5)	10,000 ± 50	394 ± 4
	ACS3-AFPWSS20	20 (0.5)	20,000 ± 50	787 ± 4
Torsion-Resistant	ACS3-AFPRSS03	20 (0.5)	3,000 ± 50	118 ± 2
	ACS3-AFPRSS05	20 (0.5)	5,000 ± 50	197 ± 2
	ACS3-AFPRSS10	20 (0.5)	10,000 ± 50	394 ± 4
	ACS3-AFPRSS20	20 (0.5)	20,000 ± 50	787 ± 4

With brake - cable exit direction towards encoder

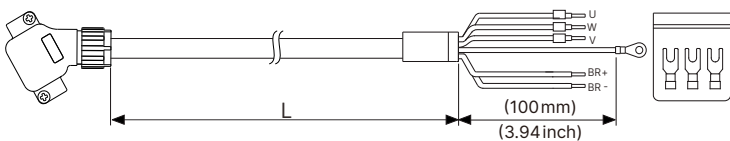

Cable	Model Name	UVW	L	
		AWG (mm ²)	mm	inch
Standard	ACS3-ABPWSS03	20 (0.5)	3,000 ± 50	118 ± 2
	ACS3-ABPWSS05	20 (0.5)	5,000 ± 50	197 ± 2
	ACS3-ABPWSS10	20 (0.5)	10,000 ± 50	394 ± 4
	ACS3-ABPWSS20	20 (0.5)	20,000 ± 50	787 ± 4
Torsion-Resistant	ACS3-ABPRSS03	20 (0.5)	3,000 ± 50	118 ± 2
	ACS3-ABPRSS05	20 (0.5)	5,000 ± 50	197 ± 2
	ACS3-ABPRSS10	20 (0.5)	10,000 ± 50	394 ± 4
	ACS3-ABPRSS20	20 (0.5)	20,000 ± 50	787 ± 4

Ordering Information

Accessories

200 V Built-in Motor with Frame Size of 80 mm or Below

Power Connector w/o Brake

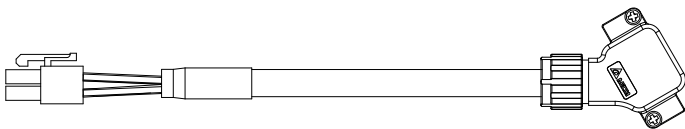

Cable	Model Name	UVW		L	
		AWG (mm ²)	mm	mm	inch
Standard	ACS3-AFPWSROC	20 (0.5)	300 ± 30	11.8 ± 1.18	
	ACS3-AFPWSROE	20 (0.5)	500 ± 30	19.7 ± 1.18	
	ACS3-AFPWSROG	20 (0.5)	700 ± 30	27.5 ± 1.18	
	ACS3-AFPWSROJ	20 (0.5)	900 ± 30	35.4 ± 1.18	
	ACS3-ABPWSROC	20 (0.5)	300 ± 30	11.8 ± 1.18	
	ACS3-ABPWSROE	20 (0.5)	500 ± 30	19.7 ± 1.18	
	ACS3-ABPWSROG	20 (0.5)	700 ± 30	27.5 ± 1.18	
	ACS3-ABPWSROJ	20 (0.5)	900 ± 30	35.4 ± 1.18	
Torsion-Resistant	ACS3-AFPFSROC	20 (0.5)	300 ± 30	11.8 ± 1.18	
	ACS3-AFPFSROE	20 (0.5)	500 ± 30	19.7 ± 1.18	
	ACS3-AFPFSROG	20 (0.5)	700 ± 30	27.5 ± 1.18	
	ACS3-AFPFSROJ	20 (0.5)	900 ± 30	35.4 ± 1.18	
	ACS3-ABPFSROC	20 (0.5)	300 ± 30	11.8 ± 1.18	
	ACS3-ABPFSROE	20 (0.5)	500 ± 30	19.7 ± 1.18	
	ACS3-ABPFSROG	20 (0.5)	700 ± 30	27.5 ± 1.18	
	ACS3-ABPFSROJ	20 (0.5)	900 ± 30	35.4 ± 1.18	

Power Connector with Brake

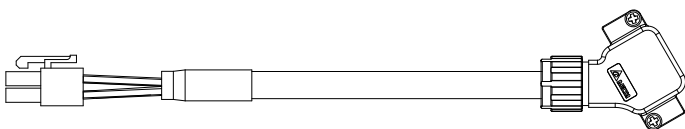

Cable	Model Name	UVW		L	
		AWG (mm ²)	mm	mm	inch
Standard	ACS3-AFPWSSOC	20 (0.5) + 24 (0.2)	300 ± 30	11.8 ± 1.18	
	ACS3-AFPWSSOE	20 (0.5) + 24 (0.2)	500 ± 30	19.7 ± 1.18	
	ACS3-AFPWSSOG	20 (0.5) + 24 (0.2)	700 ± 30	27.5 ± 1.18	
	ACS3-AFPWSSOJ	20 (0.5) + 24 (0.2)	900 ± 30	35.4 ± 1.18	
	ACS3-ABPWSSOC	20 (0.5) + 24 (0.2)	300 ± 30	11.8 ± 1.18	
	ACS3-ABPWSSOE	20 (0.5) + 24 (0.2)	500 ± 30	19.7 ± 1.18	
	ACS3-ABPWSSOG	20 (0.5) + 24 (0.2)	700 ± 30	27.5 ± 1.18	
	ACS3-ABPWSSOJ	20 (0.5) + 24 (0.2)	900 ± 30	35.4 ± 1.18	
Torsion-Resistant	ACS3-AFPFSSOC	20 (0.5) + 24 (0.2)	300 ± 30	11.8 ± 1.18	
	ACS3-AFPFSSOE	20 (0.5) + 24 (0.2)	500 ± 30	19.7 ± 1.18	
	ACS3-AFPFSSOG	20 (0.5) + 24 (0.2)	700 ± 30	27.5 ± 1.18	
	ACS3-AFPFSSOJ	20 (0.5) + 24 (0.2)	900 ± 30	35.4 ± 1.18	
	ACS3-ABPFSSOC	20 (0.5) + 24 (0.2)	300 ± 30	11.8 ± 1.18	
	ACS3-ABPFSSOE	20 (0.5) + 24 (0.2)	500 ± 30	19.7 ± 1.18	
	ACS3-ABPFSSOG	20 (0.5) + 24 (0.2)	700 ± 30	27.5 ± 1.18	
	ACS3-ABPFSSOJ	20 (0.5) + 24 (0.2)	900 ± 30	35.4 ± 1.18	

Ordering Information

Accessories

200 V Built-in Motor with Frame Size of 80 mm or Below

Signal Connector - Battery-Less / Incremental

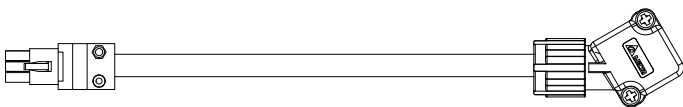

Cable	Model Name	UVW		L	
		AWG (mm ²)		mm	inch
Standard	ACS3-AFEASIOC	22 (0.3) + 26 (0.13)		300 ± 30	11.8 ± 1.18
	ACS3-AFEASIOE	22 (0.3) + 26 (0.13)		500 ± 30	19.7 ± 1.18
	ACS3-AFEASIOG	22 (0.3) + 26 (0.13)		700 ± 30	27.5 ± 1.18
	ACS3-AFEASIOJ	22 (0.3) + 26 (0.13)		900 ± 30	35.4 ± 1.18
	ACS3-ABEASIOC	22 (0.3) + 26 (0.13)		300 ± 30	11.8 ± 1.18
	ACS3-ABEASIOE	22 (0.3) + 26 (0.13)		500 ± 30	19.7 ± 1.18
	ACS3-ABEASIOG	22 (0.3) + 26 (0.13)		700 ± 30	27.5 ± 1.18
	ACS3-ABEASIOJ	22 (0.3) + 26 (0.13)		900 ± 30	35.4 ± 1.18
Torsion-Resistant	ACS3-AFERSIOC	22 (0.3) + 26 (0.13)		300 ± 30	11.8 ± 1.18
	ACS3-AFERSIOE	22 (0.3) + 26 (0.13)		500 ± 30	19.7 ± 1.18
	ACS3-AFERSIOG	22 (0.3) + 26 (0.13)		700 ± 30	27.5 ± 1.18
	ACS3-AFERSIOJ	22 (0.3) + 26 (0.13)		900 ± 30	35.4 ± 1.18
	ACS3-ABERSIOC	22 (0.3) + 26 (0.13)		300 ± 30	11.8 ± 1.18
	ACS3-ABERSIOE	22 (0.3) + 26 (0.13)		500 ± 30	19.7 ± 1.18
	ACS3-ABERSIOG	22 (0.3) + 26 (0.13)		700 ± 30	27.5 ± 1.18
	ACS3-ABERSIOJ	22 (0.3) + 26 (0.13)		900 ± 30	35.4 ± 1.18

Signal Connector - Absolute



Cable	Model Name	UVW		L	
		AWG (mm ²)		mm	inch
Standard	ACS3-AFEASA0C	22 (0.3) + 26 (0.13)		300 ± 30	11.8 ± 1.18
	ACS3-AFEASA0E	22 (0.3) + 26 (0.13)		500 ± 30	19.7 ± 1.18
	ACS3-AFEASA0G	22 (0.3) + 26 (0.13)		700 ± 30	27.5 ± 1.18
	ACS3-AFEASA0J	22 (0.3) + 26 (0.13)		900 ± 30	35.4 ± 1.18
	ACS3-ABEASA0C	22 (0.3) + 26 (0.13)		300 ± 30	11.8 ± 1.18
	ACS3-ABEASA0E	22 (0.3) + 26 (0.13)		500 ± 30	19.7 ± 1.18
	ACS3-ABEASA0G	22 (0.3) + 26 (0.13)		700 ± 30	27.5 ± 1.18
	ACS3-ABEASA0J	22 (0.3) + 26 (0.13)		900 ± 30	35.4 ± 1.18
Torsion-Resistant	ACS3-AFERSA0C	22 (0.3) + 26 (0.13)		300 ± 30	11.8 ± 1.18
	ACS3-AFERSA0E	22 (0.3) + 26 (0.13)		500 ± 30	19.7 ± 1.18
	ACS3-AFERSA0G	22 (0.3) + 26 (0.13)		700 ± 30	27.5 ± 1.18
	ACS3-AFERSA0J	22 (0.3) + 26 (0.13)		900 ± 30	35.4 ± 1.18
	ACS3-ABERSA0C	22 (0.3) + 26 (0.13)		300 ± 30	11.8 ± 1.18
	ACS3-ABERSA0E	22 (0.3) + 26 (0.13)		500 ± 30	19.7 ± 1.18
	ACS3-ABERSA0G	22 (0.3) + 26 (0.13)		700 ± 30	27.5 ± 1.18
	ACS3-ABERSA0J	22 (0.3) + 26 (0.13)		900 ± 30	35.4 ± 1.18

Ordering Information

Accessories

200V Built-in Motor with Frame Size of 80 mm or Below

Battery-Less / Incremental Encoder Connectors

Cable exit direction towards motor shaft

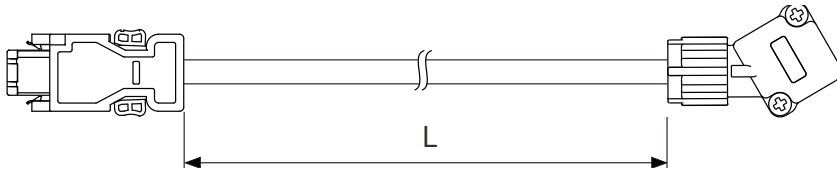

Cable	Model Name	L	
		mm	inch
Standard	ACS3-AFEASI03	3,000 ± 50	118 ± 2
	ACS3-AFEASI05	5,000 ± 50	197 ± 2
	ACS3-AFEASI10	10,000 ± 50	394 ± 4
	ACS3-AFEASI20	20,000 ± 50	787 ± 4
Torsion-Resistant	ACS3-AFERSI03	3,000 ± 50	118 ± 2
	ACS3-AFERSI05	5,000 ± 50	197 ± 2
	ACS3-AFERSI10	10,000 ± 50	394 ± 4
	ACS3-AFERSI20	20,000 ± 50	787 ± 4

Cable exit direction towards encoder

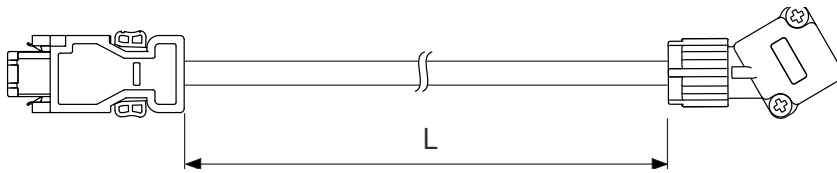

Cable	Model Name	L	
		mm	inch
Standard	ACS3-ABEASI03	3,000 ± 50	118 ± 2
	ACS3-ABEASI05	5,000 ± 50	197 ± 2
	ACS3-ABEASI10	10,000 ± 50	394 ± 4
	ACS3-ABEASI20	20,000 ± 50	787 ± 4
Torsion-Resistant	ACS3-ABERSI03	3,000 ± 50	118 ± 2
	ACS3-ABERSI05	5,000 ± 50	197 ± 2
	ACS3-ABERSI10	10,000 ± 50	394 ± 4
	ACS3-ABERSI20	20,000 ± 50	787 ± 4

Absolute Encoder Connectors

Cable exit direction towards motor shaft

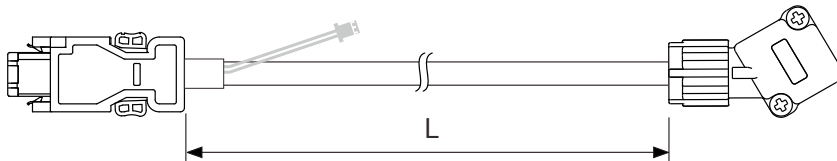

Cable	Model Name	L	
		mm	inch
Standard	ACS3-AFEASA03	3,000 ± 50	118 ± 2
	ACS3-AFEASA05	5,000 ± 50	197 ± 2
	ACS3-AFEASA10	10,000 ± 50	394 ± 4
	ACS3-AFEASA20	20,000 ± 50	787 ± 4
Torsion-Resistant	ACS3-AFERSA03	3,000 ± 50	118 ± 2
	ACS3-AFERSA05	5,000 ± 50	197 ± 2
	ACS3-AFERSA10	10,000 ± 50	394 ± 4
	ACS3-AFERSA20	20,000 ± 50	787 ± 4

Cable exit direction towards encoder

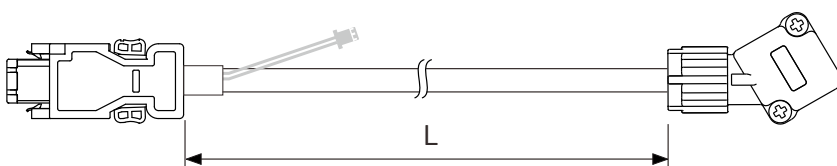

Cable	Model Name	L	
		mm	inch
Standard	ACS3-ABEASA03	3,000 ± 50	118 ± 2
	ACS3-ABEASA05	5,000 ± 50	197 ± 2
	ACS3-ABEASA10	10,000 ± 50	394 ± 4
	ACS3-ABEASA20	20,000 ± 50	787 ± 4
Torsion-Resistant	ACS3-ABERSA03	3,000 ± 50	118 ± 2
	ACS3-ABERSA05	5,000 ± 50	197 ± 2
	ACS3-ABERSA10	10,000 ± 50	394 ± 4
	ACS3-ABERSA20	20,000 ± 50	787 ± 4

Ordering Information

Accessories

Power Connectors (For F80 and below)

ASDBCAPW0000 (Motor 220 V & 400 V)
(for F80 and below)

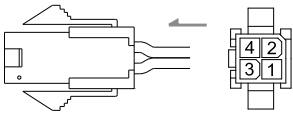

ASDBCAPW0100 (Motor 220 V & 400 V)
(for F80 and below with brake)

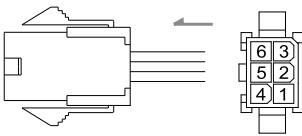

ACS3-CNPW1A00
(for F80 and below)
IP67 waterproof connector, for 220 V

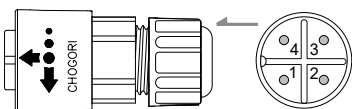

ACS3-CNPW2A00
(for F80 and below)
IP67 waterproof connector, for 220 V

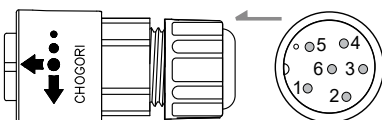

Mil-Spec Connectors (For F100 and above)

ACS3-CAPWA000
(for F100 - F130)
Mil-Spec: MIL 3106A18-10S

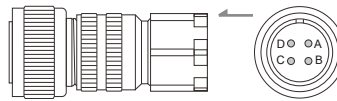

ACS3-CRPWA000
(for F100 - F130)
Mil-Spec: MIL 3108A18-10S

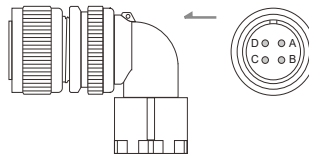

ACS3-CAPWC000
(for F180 2/3/4.5 kW)
Mil-Spec: MIL 3106A22-22S

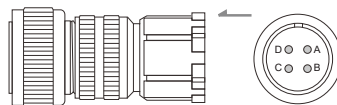

ACS3-CRPWC000
(for F180 2/3/4.5 kW)
Mil-Spec: MIL 3108A22-22S

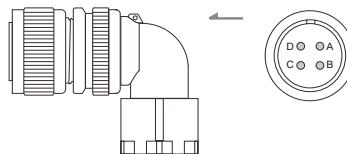

ACS3-CAPWE000
(for F180 5.5/7.5 kW & F200)
Mil-Spec: MIL 3106A32-17S

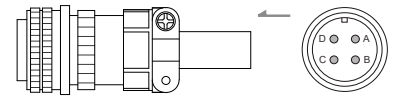

ACS3-CRPWE000
(for F180 5.5/7.5 kW & F200)
Mil-Spec: MIL 3108A32-17S

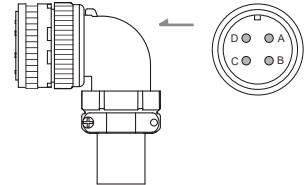

ACS3-CABRA000
(for F100 - F220 with brake)
Mil-Spec: CMV1-SP2S

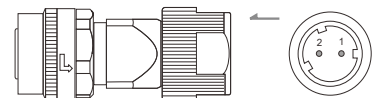

ACS3-CRBRA000
(for F100 - F220 with brake)
Mil-Spec: CMV1-AP2S

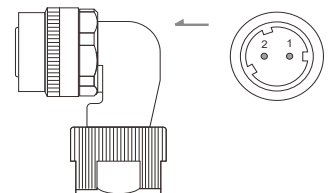

Ordering Information

Accessories

Power Cable

F40 - F80

A3/B3 motor, w/o brake, 220V

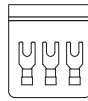
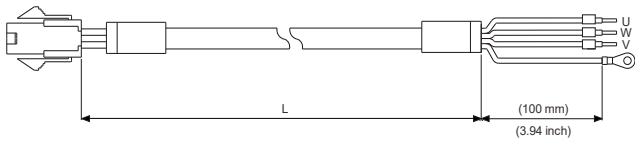

Cable	Model Name	UVW		L	
		AWG (mm ²)	mm	mm	inch
Standard	ACS3-CAPW1103	18 (0.82)	3,000 ± 50	118 ± 2	
	ACS3-CAPW1105	18 (0.82)	5,000 ± 50	197 ± 2	
	ACS3-CAPW1110	18 (0.82)	10,000 ± 50	394 ± 4	
	ACS3-CAPW1120	18 (0.82)	20,000 ± 50	787 ± 4	
Torsion-Resistant	ACS3-CAPF1103	18 (0.82)	3,000 ± 50	118 ± 2	
	ACS3-CAPF1105	18 (0.82)	5,000 ± 50	197 ± 2	
	ACS3-CAPF1110	18 (0.82)	10,000 ± 50	394 ± 4	
	ACS3-CAPF1120	18 (0.82)	20,000 ± 50	787 ± 4	

F40 - F80

A3/B3 motor, w/o brake, 400V

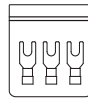
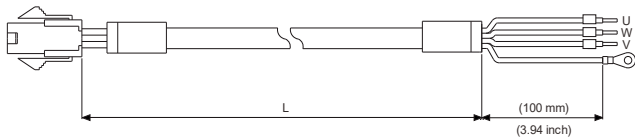

Cable	Model Name	UVW		L	
		AWG (mm ²)	mm	mm	inch
Standard	ACS3-CAPW3103	18 (0.82)	3,000 ± 50	118 ± 2	
	ACS3-CAPW3105	18 (0.82)	5,000 ± 50	197 ± 2	
	ACS3-CAPW3110	18 (0.82)	10,000 ± 50	394 ± 4	
	ACS3-CAPW3120	18 (0.82)	20,000 ± 50	787 ± 4	
Torsion-Resistant	ACS3-CAPF3103	18 (0.82)	3,000 ± 50	118 ± 2	
	ACS3-CAPF3105	18 (0.82)	5,000 ± 50	197 ± 2	
	ACS3-CAPF3110	18 (0.82)	10,000 ± 50	394 ± 4	
	ACS3-CAPF3120	18 (0.82)	20,000 ± 50	787 ± 4	

F40 - F80

A3/B3 motor, w/o brake, IP67 waterproof connector, 220V

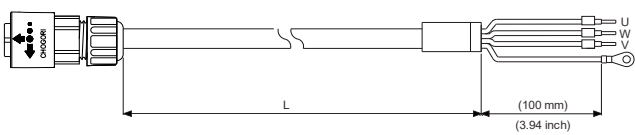

Cable	Model Name	UVW		L	
		AWG (mm ²)	mm	mm	inch
Standard	ACS3-CAPW5103	18 (0.82)	3,000 ± 50	118 ± 2	
	ACS3-CAPW5105	18 (0.82)	5,000 ± 50	197 ± 2	
	ACS3-CAPW5110	18 (0.82)	10,000 ± 100	394 ± 4	
	ACS3-CAPW5120	18 (0.82)	20,000 ± 100	787 ± 4	
Torsion-Resistant	ACS3-CAPF5103	18 (0.82)	3,000 ± 50	118 ± 2	
	ACS3-CAPF5105	18 (0.82)	5,000 ± 50	197 ± 2	
	ACS3-CAPF5110	18 (0.82)	10,000 ± 100	394 ± 4	
	ACS3-CAPF5120	18 (0.82)	20,000 ± 100	787 ± 4	

F40 - F80

A3/B3 motor, with brake (220V & 400V)

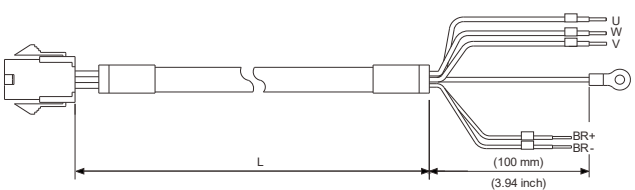

Cable	Model Name	UVW		L	
		AWG (mm ²)	mm	mm	inch
Standard	ACS3-CAPW2103	18 (0.82)	3,000 ± 50	118 ± 2	
	ACS3-CAPW2105	18 (0.82)	5,000 ± 50	197 ± 2	
	ACS3-CAPW2110	18 (0.82)	10,000 ± 100	394 ± 4	
	ACS3-CAPW2120	18 (0.82)	20,000 ± 100	787 ± 4	
Torsion-Resistant	ACS3-CAPF2103	18 (0.82)	3,000 ± 50	118 ± 2	
	ACS3-CAPF2105	18 (0.82)	5,000 ± 50	197 ± 2	
	ACS3-CAPF2110	18 (0.82)	10,000 ± 100	394 ± 4	
	ACS3-CAPF2120	18 (0.82)	20,000 ± 100	787 ± 4	

Ordering Information

Accessories

Power Cable

F40 ~ F80

A3/B3 motor, with brake, IP67 waterproof connector, for 220V

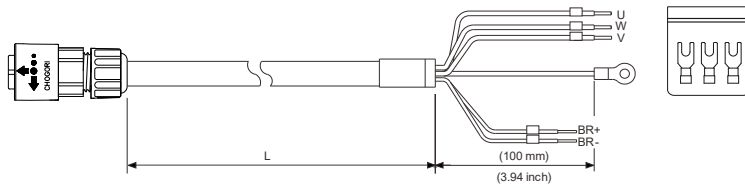

Cable	Model Name	UVW		L	
		AWG (mm ²)	mm	inch	
Standard	ACS3-CAPW6103	18 (0.82)	3,000 ± 50	118 ± 2	
	ACS3-CAPW6105	18 (0.82)	5,000 ± 50	197 ± 2	
	ACS3-CAPW6110	18 (0.82)	10,000 ± 100	394 ± 4	
	ACS3-CAPW6120	18 (0.82)	20,000 ± 100	787 ± 4	
Torsion-Resistant	ACS3-CAPF6103	18 (0.82)	3,000 ± 50	118 ± 2	
	ACS3-CAPF6105	18 (0.82)	5,000 ± 50	197 ± 2	
	ACS3-CAPF6110	18 (0.82)	10,000 ± 100	394 ± 4	
	ACS3-CAPF6120	18 (0.82)	20,000 ± 100	787 ± 4	

F100 ~ F130

B3 motor, w/o brake, straight connector

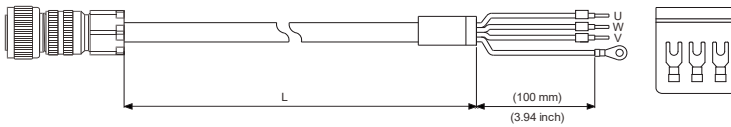

Cable	Model Name	UVW		L	
		AWG (mm ²)	mm	inch	
Standard	ACS3-CAPWA203	16 (1.3)	3,000 ± 50	118 ± 2	
	ACS3-CAPWA205	16 (1.3)	5,000 ± 50	197 ± 2	
	ACS3-CAPWA210	16 (1.3)	10,000 ± 100	394 ± 4	
	ACS3-CAPWA220	16 (1.3)	20,000 ± 100	787 ± 4	
	ACS3-CAPWA303	14 (2.1)	3,000 ± 50	118 ± 2	
	ACS3-CAPWA305	14 (2.1)	5,000 ± 50	197 ± 2	
	ACS3-CAPWA310	14 (2.1)	10,000 ± 100	394 ± 4	
	ACS3-CAPWA320	14 (2.1)	20,000 ± 100	787 ± 4	
Torsion-Resistant	ACS3-CAPFA203	16 (1.3)	3,000 ± 50	118 ± 2	
	ACS3-CAPFA205	16 (1.3)	5,000 ± 50	197 ± 2	
	ACS3-CAPFA210	16 (1.3)	10,000 ± 100	394 ± 4	
	ACS3-CAPFA220	16 (1.3)	20,000 ± 100	787 ± 4	
	ACS3-CAPFA303	14 (2.1)	3,000 ± 50	118 ± 2	
	ACS3-CAPFA305	14 (2.1)	5,000 ± 50	197 ± 2	
	ACS3-CAPFA310	14 (2.1)	10,000 ± 100	394 ± 4	
	ACS3-CAPFA320	14 (2.1)	20,000 ± 100	787 ± 4	

F100 ~ F130

B3 motor, w/o brake, angular connector

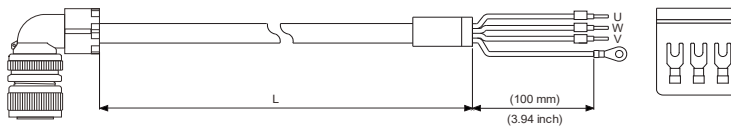

Cable	Model Name	UVW		L	
		AWG (mm ²)	mm	inch	
Standard	ACS3-CRPWA203	16 (1.3)	3,000 ± 50	118 ± 2	
	ACS3-CRPWA205	16 (1.3)	5,000 ± 50	197 ± 2	
	ACS3-CRPWA210	16 (1.3)	10,000 ± 100	394 ± 4	
	ACS3-CRPWA220	16 (1.3)	20,000 ± 100	787 ± 4	
	ACS3-CRPWA303	14 (2.1)	3,000 ± 50	118 ± 2	
	ACS3-CRPWA305	14 (2.1)	5,000 ± 50	197 ± 2	
	ACS3-CRPWA310	14 (2.1)	10,000 ± 100	394 ± 4	
	ACS3-CRPWA320	14 (2.1)	20,000 ± 100	787 ± 4	
Torsion-Resistant	ACS3-CRPFA203	16 (1.3)	3,000 ± 50	118 ± 2	
	ACS3-CRPFA205	16 (1.3)	5,000 ± 50	197 ± 2	
	ACS3-CRPFA210	16 (1.3)	10,000 ± 100	394 ± 4	
	ACS3-CRPFA220	16 (1.3)	20,000 ± 100	787 ± 4	
	ACS3-CRPFA303	14 (2.1)	3,000 ± 50	118 ± 2	
	ACS3-CRPFA305	14 (2.1)	5,000 ± 50	197 ± 2	
	ACS3-CRPFA310	14 (2.1)	10,000 ± 100	394 ± 4	
	ACS3-CRPFA320	14 (2.1)	20,000 ± 100	787 ± 4	

Ordering Information

Accessories

Power Cable

F180, 2/3/4.5 kW

B3 motor, w/o brake, straight connector

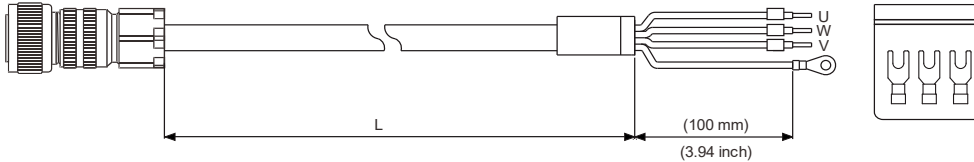

Cable	Model Name	UVW		L	
		AWG (mm ²)	mm	mm	inch
Standard	ACS3-CAP WC303	14 (2.1)	3,000 ± 50	118 ± 2	
	ACS3-CAP WC305	14 (2.1)	5,000 ± 50	197 ± 2	
	ACS3-CAP WC310	14 (2.1)	10,000 ± 100	394 ± 4	
	ACS3-CAP WC320	14 (2.1)	20,000 ± 100	787 ± 4	
	ACS3-CAP WC403	12 (3.3)	3,000 ± 50	118 ± 2	
	ACS3-CAP WC405	12 (3.3)	5,000 ± 50	197 ± 2	
	ACS3-CAP WC410	12 (3.3)	10,000 ± 100	394 ± 4	
	ACS3-CAP WC420	12 (3.3)	20,000 ± 100	787 ± 4	
	ACS3-CAP WC503	10 (5.3)	3,000 ± 50	118 ± 2	
	ACS3-CAP WC505	10 (5.3)	5,000 ± 50	197 ± 2	
	ACS3-CAP WC510	10 (5.3)	10,000 ± 100	394 ± 4	
	ACS3-CAP WC520	10 (5.3)	20,000 ± 100	787 ± 4	
	ACS3-CAP WC603	8 (8.4)	3,000 ± 50	118 ± 2	
	ACS3-CAP WC605	8 (8.4)	5,000 ± 50	197 ± 2	
	ACS3-CAP WC610	8 (8.4)	10,000 ± 100	394 ± 4	
	ACS3-CAP WC620	8 (8.4)	20,000 ± 100	787 ± 4	

Cable	Model Name	UVW		L	
		AWG (mm ²)	mm	mm	inch
Torsion-Resistant	ACS3-CAPFC303	14 (2.1)	3,000 ± 50	118 ± 2	
	ACS3-CAPFC305	14 (2.1)	5,000 ± 50	197 ± 2	
	ACS3-CAPFC310	14 (2.1)	10,000 ± 100	394 ± 4	
	ACS3-CAPFC320	14 (2.1)	20,000 ± 100	787 ± 4	
	ACS3-CAPFC403	12 (3.3)	3,000 ± 50	118 ± 2	
	ACS3-CAPFC405	12 (3.3)	5,000 ± 50	197 ± 2	
	ACS3-CAPFC410	12 (3.3)	10,000 ± 100	394 ± 4	
	ACS3-CAPFC420	12 (3.3)	20,000 ± 100	787 ± 4	
	ACS3-CAPFC503	10 (5.3)	3,000 ± 50	118 ± 2	
	ACS3-CAPFC505	10 (5.3)	5,000 ± 50	197 ± 2	
	ACS3-CAPFC510	10 (5.3)	10,000 ± 100	394 ± 4	
	ACS3-CAPFC520	10 (5.3)	20,000 ± 100	787 ± 4	
	ACS3-CAPFC603	8 (8.4)	3,000 ± 50	118 ± 2	
	ACS3-CAPFC605	8 (8.4)	5,000 ± 50	197 ± 2	
	ACS3-CAPFC610	8 (8.4)	10,000 ± 100	394 ± 4	
	ACS3-CAPFC620	8 (8.4)	20,000 ± 100	787 ± 4	

F180, 2/3/4.5 kW

B3 motor, w/o brake, angular connector

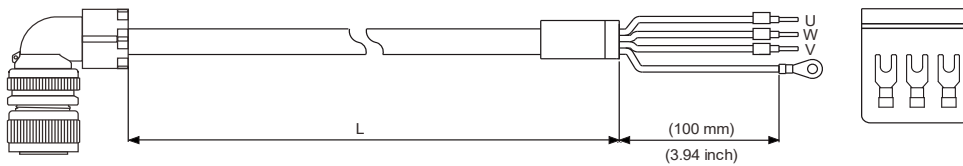

Cable	Model Name	UVW		L	
		AWG (mm ²)	mm	mm	inch
Standard	ACS3-CRP WC303	14 (2.1)	3,000 ± 50	118 ± 2	
	ACS3-CRP WC305	14 (2.1)	5,000 ± 50	197 ± 2	
	ACS3-CRP WC310	14 (2.1)	10,000 ± 100	394 ± 4	
	ACS3-CRP WC320	14 (2.1)	20,000 ± 100	787 ± 4	
	ACS3-CRP WC403	12 (3.3)	3,000 ± 50	118 ± 2	
	ACS3-CRP WC405	12 (3.3)	5,000 ± 50	197 ± 2	
	ACS3-CRP WC410	12 (3.3)	10,000 ± 100	394 ± 4	
	ACS3-CRP WC420	12 (3.3)	20,000 ± 100	787 ± 4	
	ACS3-CRP WC503	10 (5.3)	3,000 ± 50	118 ± 2	
	ACS3-CRP WC505	10 (5.3)	5,000 ± 50	197 ± 2	
	ACS3-CRP WC510	10 (5.3)	10,000 ± 100	394 ± 4	
	ACS3-CRP WC520	10 (5.3)	20,000 ± 100	787 ± 4	
	ACS3-CRP WC603	8 (8.4)	3,000 ± 50	118 ± 2	
	ACS3-CRP WC605	8 (8.4)	5,000 ± 50	197 ± 2	
	ACS3-CRP WC610	8 (8.4)	10,000 ± 100	394 ± 4	
	ACS3-CRP WC620	8 (8.4)	20,000 ± 100	787 ± 4	

Cable	Model Name	UVW		L	
		AWG (mm ²)	mm	mm	inch
Torsion-Resistant	ACS3-CRPFC303	14 (2.1)	3,000 ± 50	118 ± 2	
	ACS3-CRPFC305	14 (2.1)	5,000 ± 50	197 ± 2	
	ACS3-CRPFC310	14 (2.1)	10,000 ± 100	394 ± 4	
	ACS3-CRPFC320	14 (2.1)	20,000 ± 100	787 ± 4	
	ACS3-CRPFC403	12 (3.3)	3,000 ± 50	118 ± 2	
	ACS3-CRPFC405	12 (3.3)	5,000 ± 50	197 ± 2	
	ACS3-CRPFC410	12 (3.3)	10,000 ± 100	394 ± 4	
	ACS3-CRPFC420	12 (3.3)	20,000 ± 100	787 ± 4	
	ACS3-CRPFC503	10 (5.3)	3,000 ± 50	118 ± 2	
	ACS3-CRPFC505	10 (5.3)	5,000 ± 50	197 ± 2	
	ACS3-CRPFC510	10 (5.3)	10,000 ± 100	394 ± 4	
	ACS3-CRPFC520	10 (5.3)	20,000 ± 100	787 ± 4	
	ACS3-CRPFC603	8 (8.4)	3,000 ± 50	118 ± 2	
	ACS3-CRPFC605	8 (8.4)	5,000 ± 50	197 ± 2	
	ACS3-CRPFC610	8 (8.4)	10,000 ± 100	394 ± 4	
	ACS3-CRPFC620	8 (8.4)	20,000 ± 100	787 ± 4	

Ordering Information

Accessories

Power Cable

F180, 5.5/7.5kW

B3 motor, w/o brake, straight connector

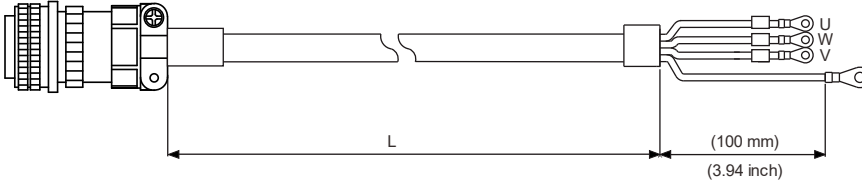

Cable	Model Name	UVW	L	
		AWG (mm ²)	mm	inch
Standard	ACS3-CAP WE603	8 (8.4)	3,000 ± 50	118 ± 2
	ACS3-CAP WE605	8 (8.4)	5,000 ± 50	197 ± 2
	ACS3-CAP WE610	8 (8.4)	10,000 ± 100	394 ± 4
	ACS3-CAP WE620	8 (8.4)	20,000 ± 100	787 ± 4
	ACS3-CAP WE703	6 (13.3)	3,000 ± 50	118 ± 2
	ACS3-CAP WE705	6 (13.3)	5,000 ± 50	197 ± 2
	ACS3-CAP WE710	6 (13.3)	10,000 ± 100	394 ± 4
	ACS3-CAP WE720	6 (13.3)	20,000 ± 100	787 ± 4
	ACS3-CAP WE803	4 (21.2)	3,000 ± 50	118 ± 2
	ACS3-CAP WE805	4 (21.2)	5,000 ± 50	197 ± 2
	ACS3-CAP WE810	4 (21.2)	10,000 ± 100	394 ± 4
	ACS3-CAP WE820	4 (21.2)	20,000 ± 100	787 ± 4

Cable	Model Name	UVW	L	
		AWG (mm ²)	mm	inch
Torsion-Resistant	ACS3-CAPFC303	14 (2.1)	3,000 ± 50	118 ± 2
	ACS3-CAPFC305	14 (2.1)	5,000 ± 50	197 ± 2
	ACS3-CAPFC310	14 (2.1)	10,000 ± 100	394 ± 4
	ACS3-CAPFC320	14 (2.1)	20,000 ± 100	787 ± 4
	ACS3-CAPFC403	12 (3.3)	3,000 ± 50	118 ± 2
	ACS3-CAPFC405	12 (3.3)	5,000 ± 50	197 ± 2
	ACS3-CAPFC410	12 (3.3)	10,000 ± 100	394 ± 4
	ACS3-CAPFC420	12 (3.3)	20,000 ± 100	787 ± 4
	ACS3-CAPFC503	10 (5.3)	3,000 ± 50	118 ± 2
	ACS3-CAPFC505	10 (5.3)	5,000 ± 50	197 ± 2
	ACS3-CAPFC510	10 (5.3)	10,000 ± 100	394 ± 4
	ACS3-CAPFC520	10 (5.3)	20,000 ± 100	787 ± 4

F180, 5.5/7.5kW

B3 motor, w/o brake, angular connector

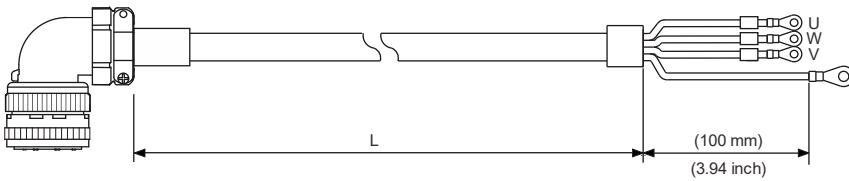

Cable	Model Name	UVW	L	
		AWG (mm ²)	mm	inch
Standard	ACS3-CRP WE603	8 (8.4)	3,000 ± 50	118 ± 2
	ACS3-CRP WE605	8 (8.4)	5,000 ± 50	197 ± 2
	ACS3-CRP WE610	8 (8.4)	10,000 ± 100	394 ± 4
	ACS3-CRP WE620	8 (8.4)	20,000 ± 100	787 ± 4
	ACS3-CRP WE703	6 (13.3)	3,000 ± 50	118 ± 2
	ACS3-CRP WE705	6 (13.3)	5,000 ± 50	197 ± 2
	ACS3-CRP WE710	6 (13.3)	10,000 ± 100	394 ± 4
	ACS3-CRP WE720	6 (13.3)	20,000 ± 100	787 ± 4
	ACS3-CRP WE803	4 (21.2)	3,000 ± 50	118 ± 2
	ACS3-CRP WE805	4 (21.2)	5,000 ± 50	197 ± 2
	ACS3-CRP WE810	4 (21.2)	10,000 ± 100	394 ± 4
	ACS3-CRP WE820	4 (21.2)	20,000 ± 100	787 ± 4

Cable	Model Name	UVW	L	
		AWG (mm ²)	mm	inch
Torsion-Resistant	ACS3-CRPFE603	8 (8.4)	3,000 ± 50	118 ± 2
	ACS3-CRPFE605	8 (8.4)	5,000 ± 50	197 ± 2
	ACS3-CRPFE610	8 (8.4)	10,000 ± 100	394 ± 4
	ACS3-CRPFE620	8 (8.4)	20,000 ± 100	787 ± 4
	ACS3-CRPFE703	6 (13.3)	3,000 ± 50	118 ± 2
	ACS3-CRPFE705	6 (13.3)	5,000 ± 50	197 ± 2
	ACS3-CRPFE710	6 (13.3)	10,000 ± 100	394 ± 4
	ACS3-CRPFE720	6 (13.3)	20,000 ± 100	787 ± 4
	ACS3-CRPFE803	4 (21.2)	3,000 ± 50	118 ± 2
	ACS3-CRPFE805	4 (21.2)	5,000 ± 50	197 ± 2
	ACS3-CRPFE810	4 (21.2)	10,000 ± 100	394 ± 4
	ACS3-CRPFE820	4 (21.2)	20,000 ± 100	787 ± 4

Ordering Information

Accessories

Power Cable

F100 - F220 Brake Cable

B3 motor, with brake, straight connector

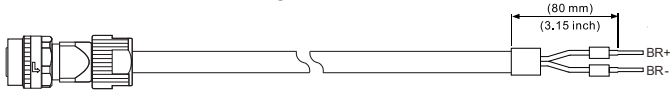

Cable	Model Name	UVW	L	
		AWG (mm ²)	mm	inch
Standard	ACS3-CABRA103	20 (0.5)	3,000 ± 50	118 ± 2
	ACS3-CABRA105	20 (0.5)	5,000 ± 50	197 ± 2
	ACS3-CABRA110	20 (0.5)	10,000 ± 100	394 ± 4
	ACS3-CABRA120	20 (0.5)	20,000 ± 100	787 ± 4
Torsion-Resistant	ACS3-CABFA103	20 (0.5)	3,000 ± 50	118 ± 2
	ACS3-CABFA105	20 (0.5)	5,000 ± 50	197 ± 2
	ACS3-CABFA110	20 (0.5)	10,000 ± 100	394 ± 4
	ACS3-CABFA120	20 (0.5)	20,000 ± 100	787 ± 4

F100 - F220 Brake Cable

B3 motor, with brake, angular connector

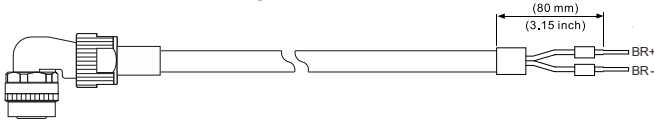

Cable	Model Name	UVW	L	
		AWG (mm ²)	mm	inch
Standard	ACS3-CRBRA103	20 (0.5)	3,000 ± 50	118 ± 2
	ACS3-CRBRA105	20 (0.5)	5,000 ± 50	197 ± 2
	ACS3-CRBRA110	20 (0.5)	10,000 ± 100	394 ± 4
	ACS3-CRBRA120	20 (0.5)	20,000 ± 100	787 ± 4
Torsion-Resistant	ACS3-CRBFA103	20 (0.5)	3,000 ± 50	118 ± 2
	ACS3-CRBFA105	20 (0.5)	5,000 ± 50	197 ± 2
	ACS3-CRBFA110	20 (0.5)	10,000 ± 100	394 ± 4
	ACS3-CRBFA120	20 (0.5)	20,000 ± 100	787 ± 4

Encoder Connectors

ACS3-CNENC200
(connecting to drive)

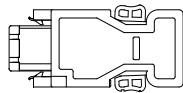

ACS3-CAENA000
(for F100 - F180)
Mil-Spec: CMV1-SP10S

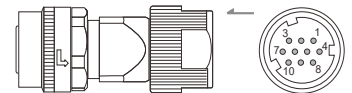

ACS3-CAEN0000
(for F80 and below)

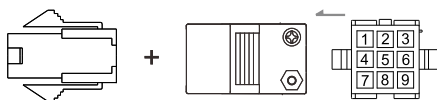

ACS3-CRENA000
(for F100 - F180)
Mil-Spec: CMV1-AP10S

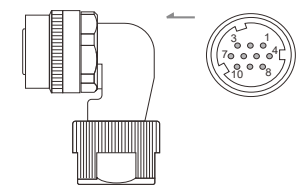

ACS3-CNEN2A00
(for F80 and below)
IP67 waterproof
connector

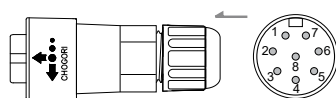

Encoder Cable (Incremental Type)

F40 ~ F80

B3 motor, w/o brake, straight connector

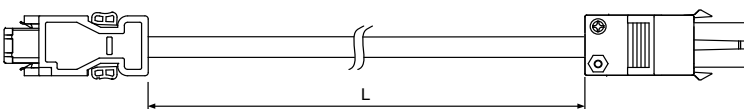

Cable	Model Name	L	
		mm	inch
Standard	ACS3-CAEN0103	3,000 ± 50	118 ± 2
	ACS3-CAEN0105	5,000 ± 50	197 ± 2
	ACS3-CAEN0110	10,000 ± 100	394 ± 4
	ACS3-CAEN0120	20,000 ± 100	787 ± 4
Torsion-Resistant	ACS3-CAEF0103	3,000 ± 50	118 ± 2
	ACS3-CAEF0105	5,000 ± 50	197 ± 2
	ACS3-CAEF0110	10,000 ± 100	394 ± 4
	ACS3-CAEF0120	20,000 ± 100	787 ± 4

Ordering Information

Accessories

Encoder Cable (Incremental Type)

F40~F80

A3/B3 motor, IP67 waterproof connector

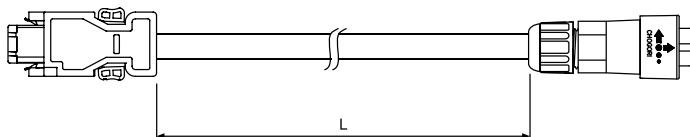

Cable	Model Name	L	
		mm	inch
Standard	ACS3-CAEN1103	3,000 ± 50	118 ± 2
	ACS3-CAEN1105	5,000 ± 50	197 ± 2
	ACS3-CAEN1110	10,000 ± 100	394 ± 4
	ACS3-CAEN1120	20,000 ± 100	787 ± 4
Torsion-Resistant	ACS3-CAEF1103	3,000 ± 50	118 ± 2
	ACS3-CAEF1105	5,000 ± 50	197 ± 2
	ACS3-CAEF1110	10,000 ± 100	394 ± 4
	ACS3-CAEF1120	20,000 ± 100	787 ± 4

F100~F180

B3 motor, straight connector

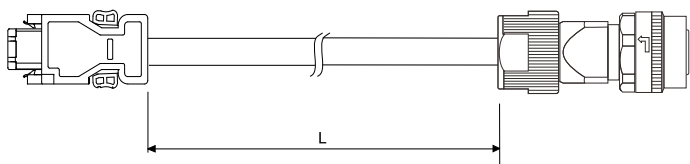

Cable	Model Name	L	
		mm	inch
Standard	ACS3-CAENA103	3,000 ± 50	118 ± 2
	ACS3-CAENA105	5,000 ± 50	197 ± 2
	ACS3-CAENA110	10,000 ± 100	394 ± 4
	ACS3-CAENA120	20,000 ± 100	787 ± 4
Torsion-Resistant	ACS3-CAEFA103	3,000 ± 50	118 ± 2
	ACS3-CAEFA105	5,000 ± 50	197 ± 2
	ACS3-CAEFA110	10,000 ± 100	394 ± 4
	ACS3-CAEFA120	20,000 ± 100	787 ± 4

F100~F180

A3/B3 motor, angular connector

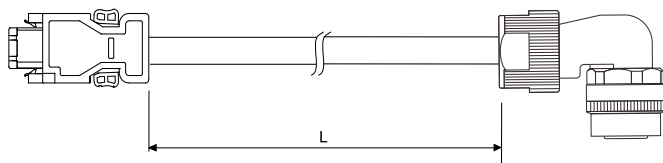

Cable	Model Name	L	
		mm	inch
Standard	ACS3-CREN0103	3,000 ± 50	118 ± 2
	ACS3-CREN0105	5,000 ± 50	197 ± 2
	ACS3-CREN0110	10,000 ± 100	394 ± 4
	ACS3-CREN0120	20,000 ± 100	787 ± 4
Torsion-Resistant	ACS3-CREF0103	3,000 ± 50	118 ± 2
	ACS3-CREF0105	5,000 ± 50	197 ± 2
	ACS3-CREF0110	10,000 ± 100	394 ± 4
	ACS3-CREF0120	20,000 ± 100	787 ± 4

Encoder Cable (Absolute Type)

F40~F80

A3/B3 motor

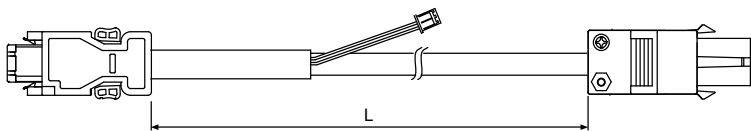

Cable	Model Name	L	
		mm	inch
Standard	ACS3-CAEA0103	3,000 ± 50	118 ± 2
	ACS3-CAEA0105	5,000 ± 50	197 ± 2
	ACS3-CAEA0110	10,000 ± 100	394 ± 4
	ACS3-CAEA0120	20,000 ± 100	787 ± 4
Torsion-Resistant	ACS3-CAEB0103	3,000 ± 50	118 ± 2
	ACS3-CAEB0105	5,000 ± 50	197 ± 2
	ACS3-CAEB0110	10,000 ± 100	394 ± 4
	ACS3-CAEB0120	20,000 ± 100	787 ± 4

F40~F80

A3/B3 motor, IP67 waterproof connector

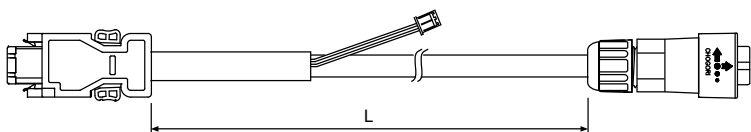

Cable	Model Name	L	
		mm	inch
Standard	ACS3-CAEA1103	3,000 ± 50	118 ± 2
	ACS3-CAEA1105	5,000 ± 50	197 ± 2
	ACS3-CAEA1110	10,000 ± 100	394 ± 4
	ACS3-CAEA1120	20,000 ± 100	787 ± 4
Torsion-Resistant	ACS3-CAEB1103	3,000 ± 50	118 ± 2
	ACS3-CAEB1105	5,000 ± 50	197 ± 2
	ACS3-CAEB1110	10,000 ± 100	394 ± 4
	ACS3-CAEB1120	20,000 ± 100	787 ± 4

Ordering Information

Accessories

Encoder Cable (Absolute Type)

F100 - F180

A3/B3 motor, straight connector

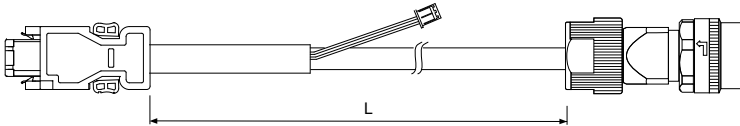

Cable	Model Name	L	
		mm	inch
Standard	ACS3-CAEAA103	3,000 ± 50	118 ± 2
	ACS3-CAEAA105	5,000 ± 50	197 ± 2
	ACS3-CAEAA110	10,000 ± 100	394 ± 4
	ACS3-CAEAA120	20,000 ± 100	787 ± 4
Torsion-Resistant	ACS3-CAEBA103	3,000 ± 50	118 ± 2
	ACS3-CAEBA105	5,000 ± 50	197 ± 2
	ACS3-CAEBA110	10,000 ± 100	394 ± 4
	ACS3-CAEBA120	20,000 ± 100	787 ± 4

F100 - F180

A3/B3 motor, angular connector

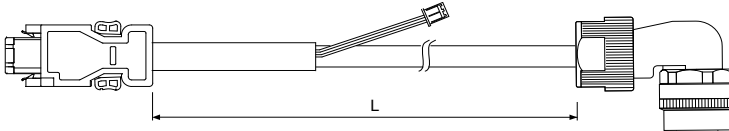

Cable	Model Name	L	
		mm	inch
Standard	ACS3-CREAA103	3,000 ± 50	118 ± 2
	ACS3-CREAA105	5,000 ± 50	197 ± 2
	ACS3-CREAA110	10,000 ± 100	394 ± 4
	ACS3-CREAA120	20,000 ± 100	787 ± 4
Torsion-Resistant	ACS3-CREBA103	3,000 ± 50	118 ± 2
	ACS3-CREBA105	5,000 ± 50	197 ± 2
	ACS3-CREBA110	10,000 ± 100	394 ± 4
	ACS3-CREBA120	20,000 ± 100	787 ± 4

Absolute Battery Box

Single Battery Box ASD-MDBT0100

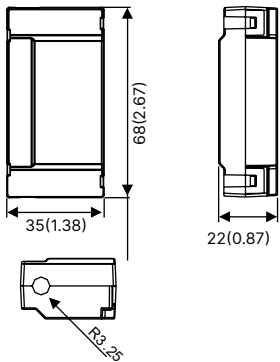

Double Battery Box ASD-MDBT0200

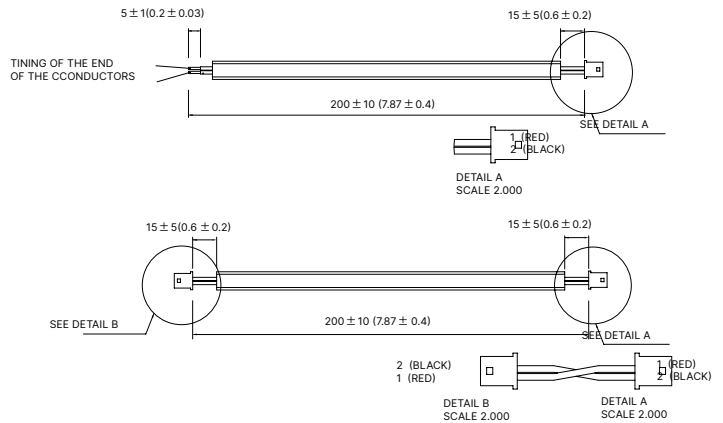
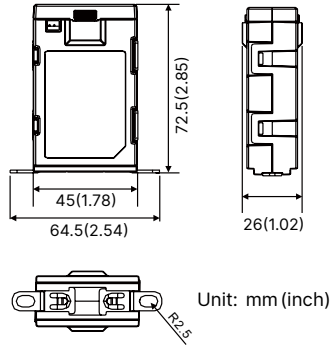

Note: Contact Delta Global Service team if ordering battery box cord only

CN1 Terminal Block Module

ACS3-MDTB4400 (for B3-L)

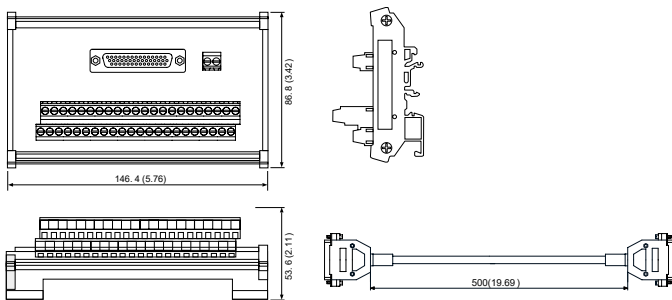

Unit: mm (inch)

ACS3-MDTD2600 (for B3-M, F, and E)

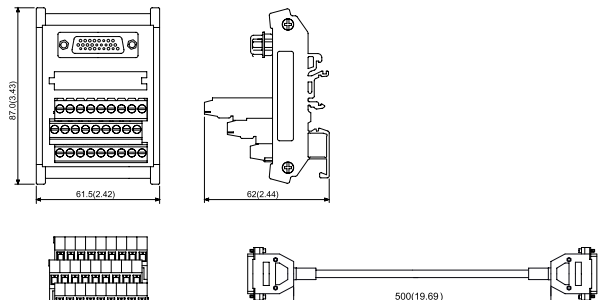

Unit: mm (inch)

Ordering Information

Accessories

CCN3 CANopen Communication Cable

UC-CMC030-01A · UC-CMC050-01A

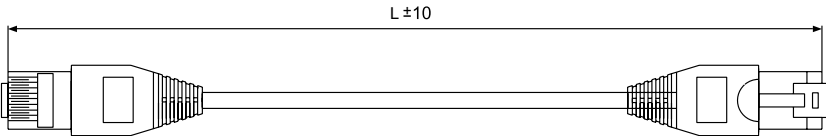

Item	Part No.	L	
		mm	inch
1	UC-CMC030-01A	3,000 ± 10	11 ± 0.4
2	UC-CMC050-01A	5,000 ± 10	19 ± 0.4

CN1 Connectors

ACS3-IFSC4444 (for B3-L)

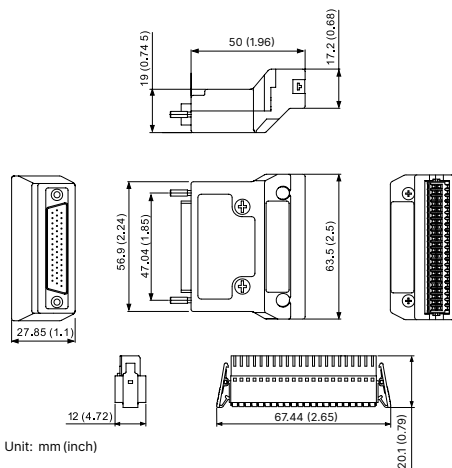

ACS3-IFSC2626 (for B3-M, F, and E)

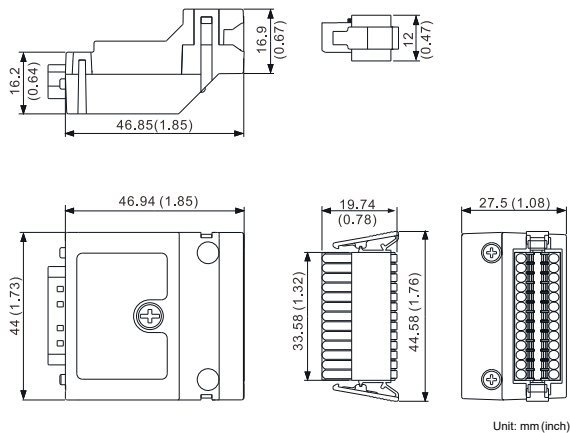

CN1 Connectors

ACS3-CNTB0400 (for B3-L)

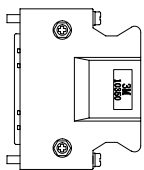

ACS3-CNTB0500 (for B3-M, F, and E)

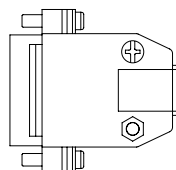

CN3 CANopen Distribution Box

TAP-CN03

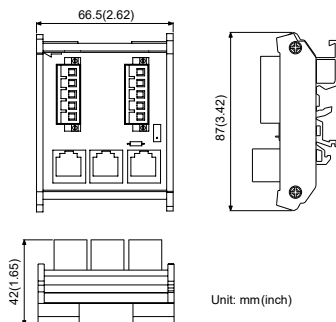

CN3 RS-485 Tap

ACS3-CNADC3RC

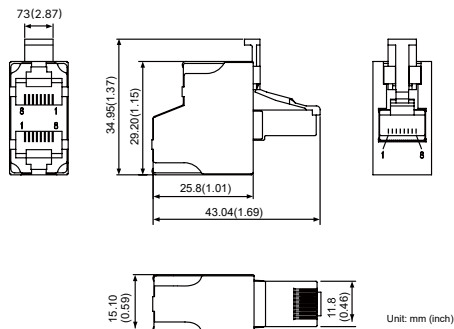

Ordering Information

Accessories

B3/B2 Conversion Cables

B3/B2 CN1 conVersion cable (for B3-L)
ACS3-CABDC1

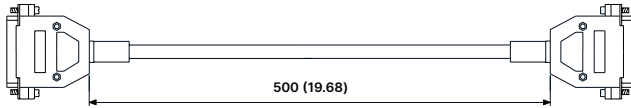

B3/B2 CN2 conversion cable
ACS3-CABDC2

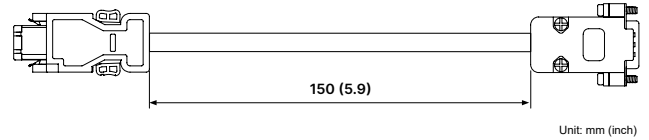

Unit: mm (inch)

CN3 RS-485/CANOpen Terminal Resistor

ACS3-CNADC3TR

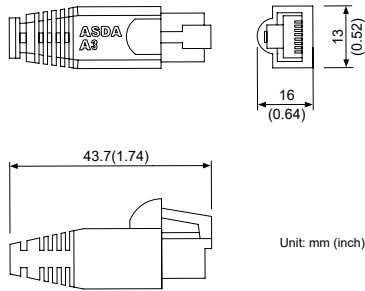

Unit: mm (inch)

CN6 DMCNET Terminal Resistor

ASD-TR-DM0008

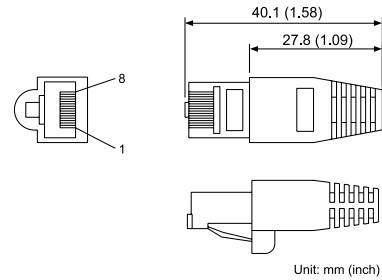

Unit: mm (inch)

CN4 Mini USB Communication Module

UC-PRG015-01B · UC-PRG030-01B

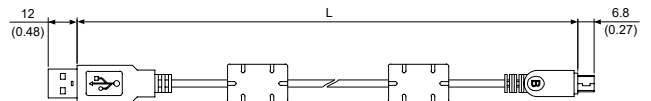
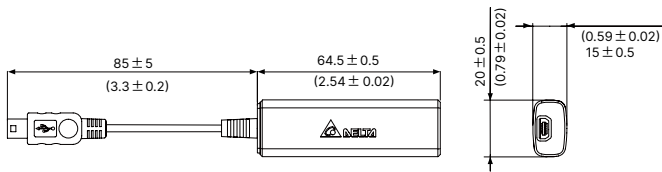

Unit: mm (inch)

Item	Part No.	L	
		mm	inch
1	UC-PRG015-01B	1,500 ± 10	59 ± 4
2	UC-PRG030-01B	3,000 ± 10	118 ± 4

CN4 Mini USB Communication Module

UC-ADP01-A

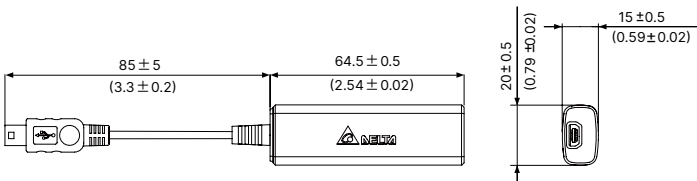

UC-PRG015-01A · UC-PRG030-01A

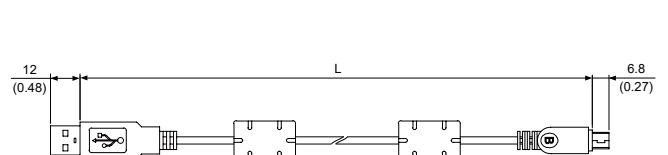

Unit: mm (inch)

Item	Part No.	L	
		mm	inch
1	UC-PRG015-01A	1,500 ± 10	59 ± 4
2	UC-PRG030-01A	3,000 ± 10	118 ± 4

Ordering Information

B3 Motor Accessory

Service Bag P/N	Contents
3534667300	A+B
3534851300	A+B+C
3534850500	D+E
3534781100	C+D+E
3525801800	F+G

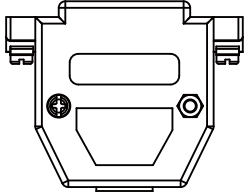
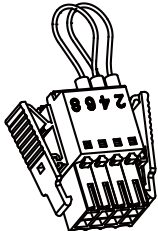
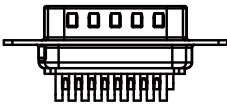
Item	P/N	Picture
A	3074046787	
B	3050038500	
C	3050027000	
D	307404258Z	

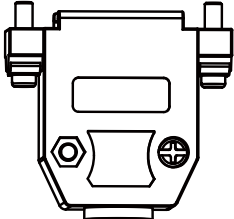
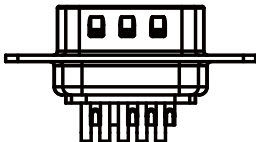
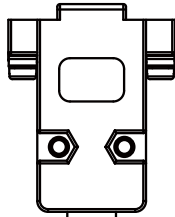
Item	P/N	Picture
E	3050038600	
F	3074047782	
G	3050038400	

Servo Drive Standards

Standard	ASD-B3 servo drive conforms to the highest standards and recommendations for electrical industrial control equipment (IEC, EN)
EMC Immunity	EN61000-4-6 Level 3
	EN61000-4-3 Level 3
	EN61000-4-2 Level 2 and 3
	EN61000-4-4 Level 3
	EN61000-4-8 Level 4
	EN61000-4-5 Level 3
Conducted and Radiated EMC Interference of Servo Drive	EN61800-3 Level 3, with external EMC filter
CE Marking	B3 series servo drives have the CE marking and conform to the European Union Low Voltage Directive (2014/35/EU) and EMC Directive (2014/30/EU)
Product Certification	UL (USA); cUL (CA) Note: B3 400V (with no UL)
STO	EN 61800-5-2:2007
	EN 61800-5-2:2017
	EN 61800-5-1:2007 + A1:2017, 4.3, 5.2.3.8, 5.2.6
	EN IEC 61800-3:2018
	EN 62061:2005 + AC:2010 + A1:2013 + A2:2015
	EN ISO 13849-1:2015
	EN 61508 Parts 1-7:2010
Protection Level	IEC/EN50178, IP20
Vibration Resistance Protection	20Hz and below (1G), 20 ~ 50Hz (0.6G) conforms to IEC/EN50178
Shock Resistance Protection	15gn 11ms conforms to IEC/EN600028-2-27

Servo Drive Standards

Pollution Degree	Degree 2 conforms to IEC/EN61800-5-1
CE	EN 60034-1
Certification	UL, CE, cRUus
Protection Level	IP67
Vibration Resistance Protection	30 Hz \leq f \leq 2,000 Hz Fix Acceleration: 5 G
Energy Efficiency Certification	CHINA ENERGY (Power > 550 W)





Smarter. Greener. Together.

Industrial Automation Headquarters

Taiwan: Delta Electronics, Inc.

Taoyuan Technology Center
No.18, Xinglong Rd., Taoyuan District,
Taoyuan City 33068, Taiwan
TEL: +886-3-362-6301 / FAX: +886-3-371-6301

Asia

China: Delta Electronics (Shanghai) Co., Ltd.

No.182 Minyu Rd., Pudong Shanghai, P.R.C.
Post code : 201209
TEL: +86-21-6872-3988 / FAX: +86-21-6872-3996
Customer Service: 400-820-9595

Japan: Delta Electronics (Japan), Inc.

Industrial Automation Sales Department
2-1-14 Shibadaimon, Minato-ku
Tokyo, Japan 105-0012
TEL: +81-3-5733-1155 / FAX: +81-3-5733-1255

Korea: Delta Electronics (Korea), Inc.

1511, 219, Gasan Digital 1-Ro., Geumcheon-gu,
Seoul, 08501 South Korea
TEL: +82-2-515-5305 / FAX: +82-2-515-5302

Singapore: Delta Energy Systems (Singapore) Pte Ltd.

4 Kaki Bukit Avenue 1, #05-04, Singapore 417939
TEL: +65-6747-5155 / FAX: +65-6744-9228

India: Delta Electronics (India) Pvt. Ltd.

Plot No.43, Sector 35, HSIIDC Gurgaon,
PIN 122001, Haryana, India
TEL: +91-124-4874900 / FAX: +91-124-4874945

Thailand: Delta Electronics (Thailand) PCL.

909 Soi 9, Moo 4, Bangpoo Industrial Estate (E.P.Z),
Pattana 1 Rd., T.Phraksa, A.Muang,
Samutprakarn 10280, Thailand
TEL: +66-2709-2800 / FAX: +66-2709-2827

Australia: Delta Electronics (Australia) Pty Ltd.

Unit 2, Building A, 18-24 Ricketts Road,
Mount Waverley, Victoria 3149 Australia
Mail: IA.au@deltaww.com
TEL: +61-1300-335-823 / +61-3-9543-3720

Americas

USA: Delta Electronics (Americas) Ltd.

5101 Davis Drive, Research Triangle Park, NC 27709, U.S.A.
TEL: +1-919-767-3813

Brazil: Delta Electronics Brazil Ltd.

Estrada Velha Rio-São Paulo, 5300 Eugênio de
Melo - São José dos Campos CEP: 12247-004 - SP - Brazil
TEL: +55-12-3932-2300 / FAX: +55-12-3932-237

Mexico: Delta Electronics International Mexico S.A. de C.V.

Gustavo Baz No. 309 Edificio E PB 103
Colonia La Loma, CP 54060
Tlalnepantla, Estado de México
TEL: +52-55-3603-9200

EMEA

EMEA Headquarters: Delta Electronics (Netherlands) B.V.

Sales: Sales.IA.EMEA@deltaww.com
Marketing: Marketing.IA.EMEA@deltaww.com
Technical Support: iatechnicalsupport@deltaww.com
Customer Support: Customer-Support@deltaww.com
Service: Service.IA.emea@deltaww.com
TEL: +31(0)40 800 3900

BENELUX: Delta Electronics (Netherlands) B.V.

Automotive Campus 260, 5708 JZ Helmond, The Netherlands
Mail: Sales.IA.Benelux@deltaww.com
TEL: +31(0)40 800 3900

DACH: Delta Electronics (Netherlands) B.V.

Coesterweg 45, D-59494 Soest, Germany
Mail: Sales.IA.DACH@deltaww.com
TEL: +49 2921 987 238

France: Delta Electronics (France) S.A.

ZI du bois Challand 2, 15 rue des Pyrénées,
Lisses, 91090 Evry Cedex, France
Mail: Sales.IA.FR@deltaww.com
TEL: +33(0)1 69 77 82 60

Iberia: Delta Electronics Solutions (Spain) S.L.U

Ctra. De Villaverde a Vallecas, 265 1º Dcha Ed.
Hormigueras - P.I. de Vallecas 28031 Madrid
TEL: +34(0)91 223 74 20

Carrer Llacuna 166, 08018 Barcelona, Spain

Mail: Sales.IA.Iberia@deltaww.com

Italy: Delta Electronics (Italy) S.r.l.

Via Meda 2-22060 Novedrate(CO)
Piazza Grazioli 18 00186 Roma Italy
Mail: Sales.IA.Italy@deltaww.com
TEL: +39 039 8900365

Turkey: Delta Greentech Elektronik San. Ltd. Sti. (Turkey)

Şerifali Mah. Hendem Cad. Kule Sok. No:16-A
34775 Ümraniye - İstanbul
Mail: Sales.IA.Turkey@deltaww.com
TEL: + 90 216 499 9910

MEA: Eltek Dubai (Eltek MEA DMCC)

OFFICE 2504, 25th Floor, Saba Tower 1,
Jumeirah Lakes Towers, Dubai, UAE
Mail: Sales.IA.MEA@deltaww.com
TEL: +971(0)4 2690148

DELTA_IA-ASDA_ASDA-B3_C_EN_20240703

*We reserve the right to change the information in this catalogue without prior notice.

DELTA_IA-ASDA_ASDA-B3_C_EN_20240502