

## ECM-B3 Built-in Series Servo Motor Specifications

220 V Dimensions of Motors with Frame Size of 80 mm or Below

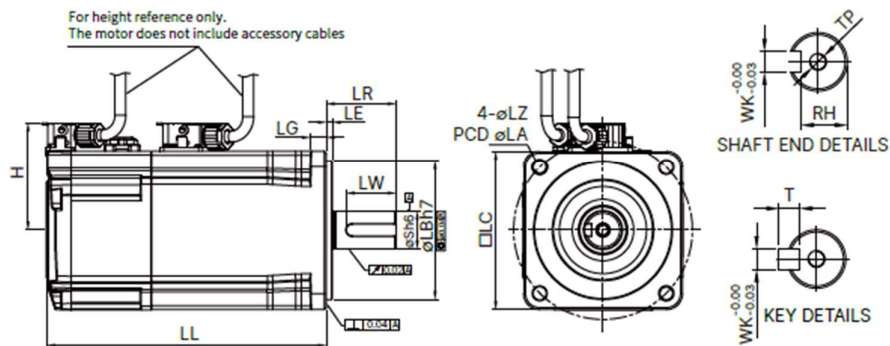

Model	B3L-C (2) 0401	B3M-C (2) 0602	B3M-C (2) 0604	B3M-C (2) 0807
LC	40	60	60	80
LZ	5.5	5.5	5.5	6.6
LA	70	70	70	90
S	14 <sup>(+0 -0.011)</sup>	14 <sup>(+0 -0.011)</sup>	14 <sup>(+0 -0.011)</sup>	19 <sup>(+0 -0.013)</sup>
LB	50 <sup>(+0 -0.025)</sup>	50 <sup>(+0 -0.025)</sup>	50 <sup>(+0 -0.025)</sup>	70 <sup>(+0 -0.030)</sup>
LL (w/o brake)	76.2	72.5	91	105.2
LL (with brake)	107.7	104.4	122.9	144.8
LH	300	300	300	300
LP	300	300	300	300
H	44	44	44	54
LR	30	30	30	35
LE	2.5	3	3	3
LG	7.5	7.5	7.5	8
LW	20	20	20	25
RH	11	11	11	15.5
WK	5	5	5	6
W	5	5	5	6
T	5	5	5	6
TP	M4 Depth 15	M4 Depth 15	M4 Depth 15	M6 Depth 20

Note: 1. Servo motor model name: (2) = encoder type  
2. The length of battery-less encoder frame LL increases as shown below

F40	F60	F80
+5.8mm	+6.4mm	+6mm

## ECM-B3 Built-in Series LW Servo Motor Specifications

220 V Dimensions of Motors with Frame Size of 80 mm or Below

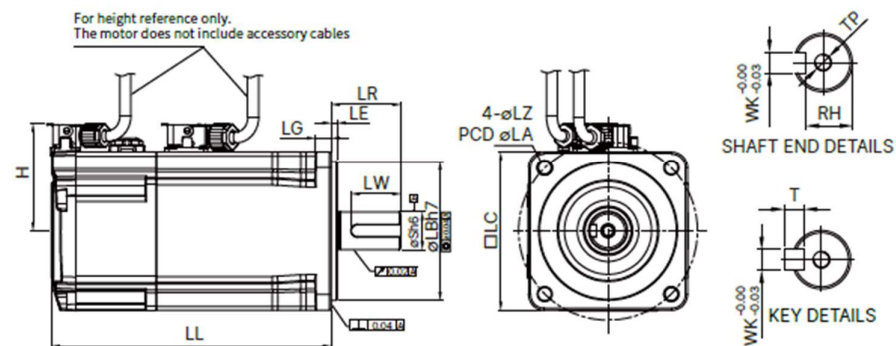

Model	B3M-C (2) 0810	B3H-C (2) 0602	B3H-C (2) 0604	B3H-C (2) 807
LC	80	60	60	80
LZ	6.6	5.5	5.5	6.6
LA	90	70	70	90
S	19 <sup>(+0 -0.013)</sup>	14 <sup>(+0 -0.011)</sup>	14 <sup>(+0 -0.011)</sup>	19 <sup>(+0 -0.013)</sup>
LB	70 <sup>(+0 -0.030)</sup>	50 <sup>(+0 -0.025)</sup>	50 <sup>(+0 -0.025)</sup>	70 <sup>(+0 -0.030)</sup>
LL (w/o brake)	118.8	69.6	87.45	95.4
LL (with brake)	154.4	101.5	119.35	131
LH	300	300	300	300
LP	300	300	300	300
H	54	44	44	54
LR	35	30	30	35
LE	3	3	3	3
LG	8	7.5	7.5	8
LW	25	20	20	25
RH	15.5	11	11	15.5
WK	6	5	5	6
W	6	5	5	6
T	6	5	5	6
TP	M6 Depth 20	M4 Depth 15	M4 Depth 15	M6 Depth 20

Note: 1. Servo motor model name: (2) = encoder type  
2. The length of battery-less encoder frame LL increases as shown below

F40	F60	F80
+5.8mm	+6.4mm	+6mm