

Absolute System

10

This chapter introduces the absolute servo system, including the wiring and installation of the absolute encoder, the steps to set up the system, and the procedures for initializing and operating the system for the first time.

10.1	Battery box and absolute encoder cable	10-3
10.1.1	Battery specifications	10-3
10.1.2	Battery box dimensions	10-5
10.1.3	Connection cable for the absolute encoder	10-6
10.1.4	Battery box cable	10-11
10.2	Installation	10-12
10.2.1	Installing the battery box in the servo system	10-12
10.2.2	Installing and replacing a battery	10-14
10.3	System initialization and operating procedures	10-16
10.3.1	System initialization	10-16
10.3.2	Pulse number	10-17
10.3.3	PUU number	10-18
10.3.4	Establish the absolute origin position	10-19
10.3.4.1	Establishing the absolute origin position with DI/DO	10-19
10.3.4.2	Establishing the absolute origin position with parameters	10-20
10.3.4.3	Establishing the absolute origin position with the PR homing function	10-20
10.3.5	Reading the absolute position	10-20
10.3.5.1	Establishing the absolute origin position with DI/DO	10-20
10.3.5.2	Reading the absolute position with communication	10-23
10.4	Parameters, DI/DO, and alarms related to absolute function	10-24

10

Important

A complete absolute servo system includes a servo drive, an absolute motor, and a backup battery box. The backup battery supplies power to the system so that the encoder continues operating when the main power to the servo drive is off. In addition, the absolute encoder can continuously record the motor's actual position at any time, even when the motor shaft is rotated after the power is off. The absolute servo system must be used only with an absolute motor. If the servo is set up with an incremental motor and the absolute function is enabled (P2.069.X = 1), AL069 occurs.

When using an absolute motor, make sure the motor speed is lower than 250 rpm at the moment when power is on. When the encoder is operating with the battery, make sure the maximum speed of the motor does not exceed 200 rpm.

To determine whether you use an absolute motor, check the model number as shown in the following:

ECM-A3 series servo motor

ECM - A3 □ - □ □ □ □ □ □ □ □ □ □
└ A / Y: absolute motor

ECM-B3 series servo motor

ECM - B3 □ - □ □ □ □ □ □ □ □ □ □
└ A / P: absolute motor

ECMC series servo motor

ECMC - □ W □ □ □ □ □ □ □ □
└ W / V: absolute motor

Install the battery correctly on the encoder. One servo drive uses one single battery box; two servo drives can share one dual battery box. Use Delta's encoder cable to connect to the battery box. See the following sections for the specifications of the battery box and its accessories.

10.1 Battery box and absolute encoder cable

10.1.1 Battery specifications

Precautions

Carefully read the following safety precautions. Use batteries only in accordance with the specifications to avoid damage or dangerous conditions.



- Make sure the installation location is free of vapor and corrosive and inflammable gas.
- Correctly place the battery into the battery box to avoid short-circuiting.
- Do not short-circuit the positive and negative electrodes of the battery, and do not install the batteries in reverse direction.
- Do not mix new and used batteries to avoid losing power or shortening the life of the new batteries. Replacing all batteries with new ones is recommended.
- Follow the instructions when installing and wiring the battery box to avoid dangerous conditions.



- Do not place the battery in a high-temperature environment over 100°C (212°F), as this may cause a fire or an explosion.
- The batteries are non-rechargeable. Do not charge the batteries as this may result in an explosion.
- Do not directly weld on the surface of the battery.

Battery specifications

Item	Li/SOCI2 Cylindrical Battery
Type	ER14505
Delta model number	ASD-CLBT0100
International standard size	AA
Standard voltage	3.6V
Standard capacity	2700 mAh
Maximum continuous discharge current	100 mA
Maximum pulse current	200 mA
Dimensions (D x H)	14.5 x 50.5 mm
Weight	Approx. 19 g
Operating temperature	-40°C to +85°C (-40°F to +185°F)
Supplier	EVE Energy Co., Ltd
Part number for the battery with wires	0991023281

Battery life

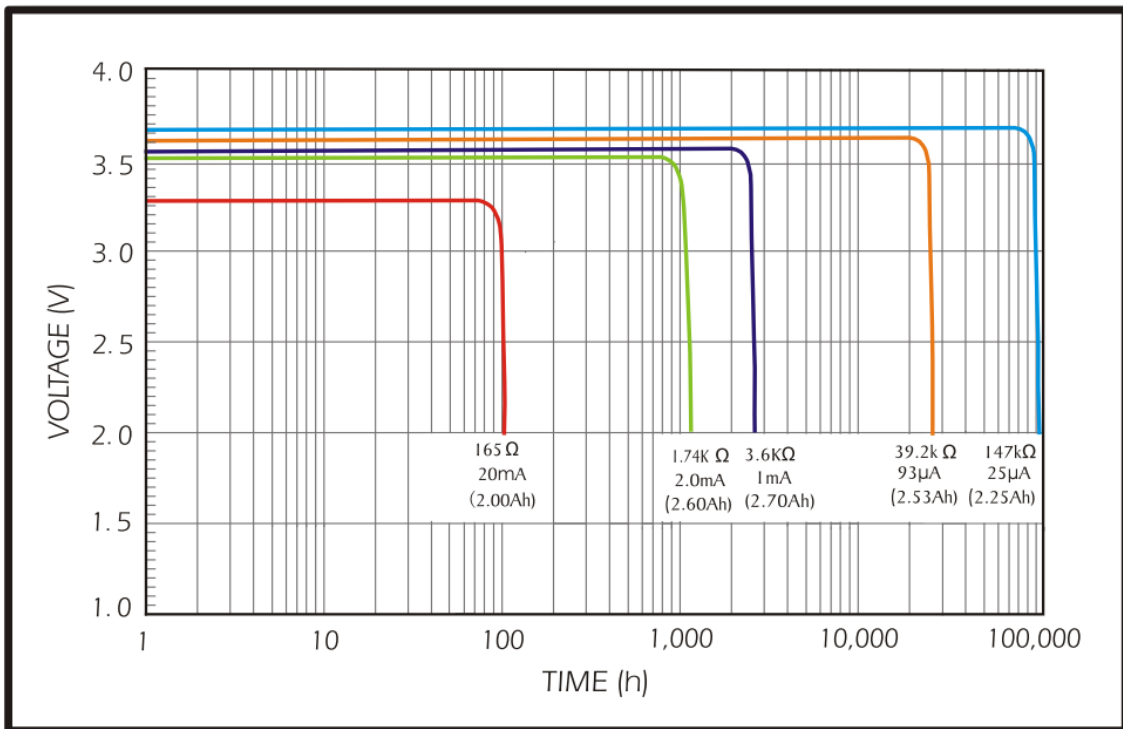

Source: EVE Energy Co. ER14505 Discharge Characteristics

(1) The preceding figure illustrates the discharge current curves measured in the constant current test. According to the five curves shown in the preceding figure, if the battery voltage keeps at 3V or higher, the expected battery life is as shown in the following table. Therefore, the lowest battery voltage for an absolute encoder is set to 3.1V.

Motor	Current consumption ^{*2} (μA) when the encoder operates with the battery	Battery life expectancy (month)
ECM-A3□□A□□□□□□□□	30	87.5
ECM-B3□□A□□□□□□□□		
ECM-B3□□P□□□□□□□□		
ECMC□□W□□□□□□□□	45	58.33
ECM-A3□□Y□□□□□□□□		
ECMC□□V□□□□□□□□	35	75

(2) The battery voltage can keep at 3.6V or above up to 5 years when the battery is stored in a cool dry place.

Note:

1. The battery life expectancy is measured with a test using a servo drive, a motor, and a single battery.
2. The current consumption is nearly 0 when the absolute origin position is not established. Once the absolute origin position is established, the battery power consumption starts. To avoid battery power consumption when the machine is in transport, it is recommended that you disconnect the battery from the servo drive or do not establish the absolute origin position.

10.1.2 Battery box dimensions

Single battery box

Delta model number: ASD-MDBT0100

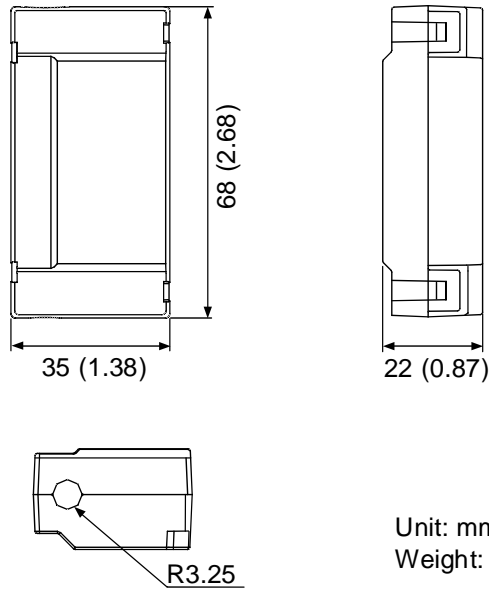

Unit: mm (inch)
Weight: 44 g

10

Dual battery box

Delta model number: ASD-MDBT0200

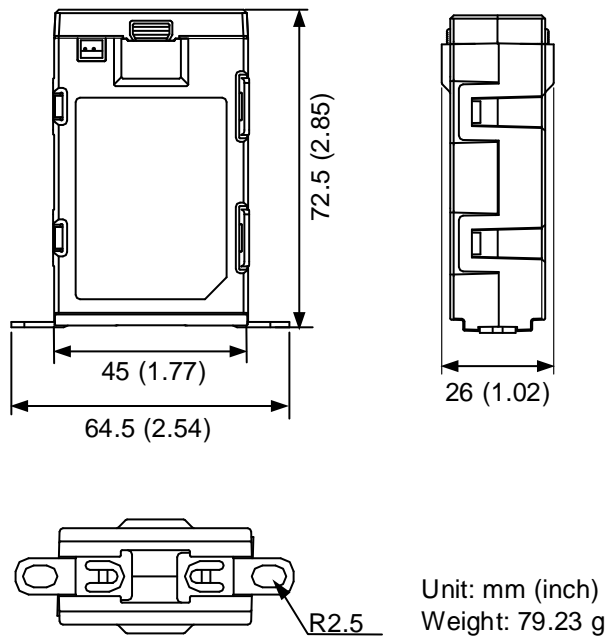

Unit: mm (inch)
Weight: 79.23 g

10

10.1.3 Connection cable for the absolute encoder

A. Standard connector

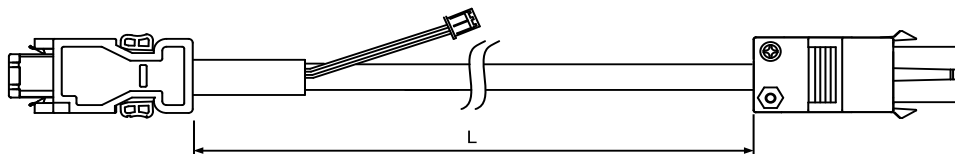

Model number of absolute encoder cable	L	
	mm	inch
ACS3-CAE□0103	3000 ± 50	118 ± 2
ACS3-CAE□0105	5000 ± 50	197 ± 2
ACS3-CAE□0110	10000 ± 100	394 ± 4
ACS3-CAE□0120	20000 ± 100	787 ± 4

Note: select cables according to the □ in the model number. B represents flexible cables and A represents standard cables.

Connection method:

Caution Follow these instructions when wiring. Incorrect wiring may cause battery explosion.

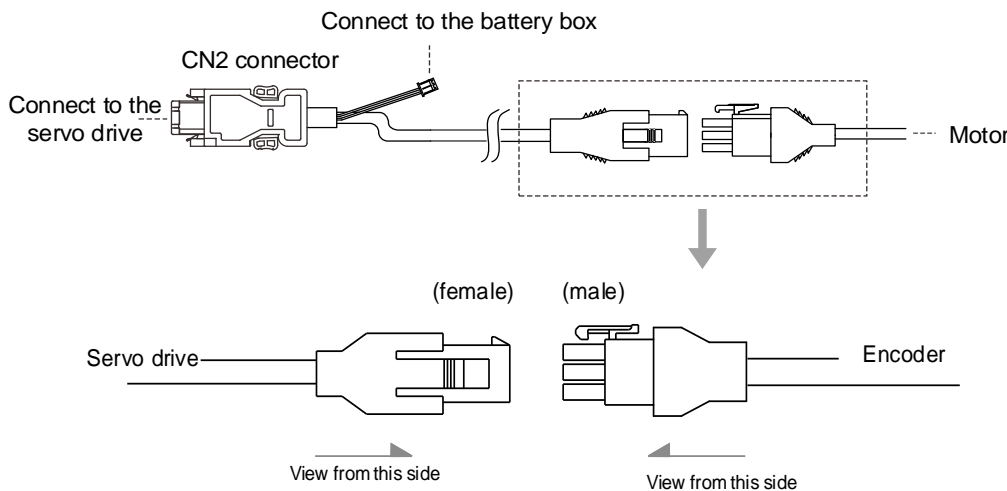

1 White T+	2 Red BAT+	3 Reserved
4 White/Red T-	5 Black BAT-	6 Reserved
7 Brown DC+5V	8 Blue GND	9 Shielding

3 Reserved	2 Black BAT+	1 White T+
6 Reserved	5 Red/Black BAT-	4 White/Red T-
9 Shielding	8 Blue GND	7 Brown DC+5V

Note: the wire colors of the encoder cable for the servo drive are for reference only. Refer to the actual product.

B. Military connector

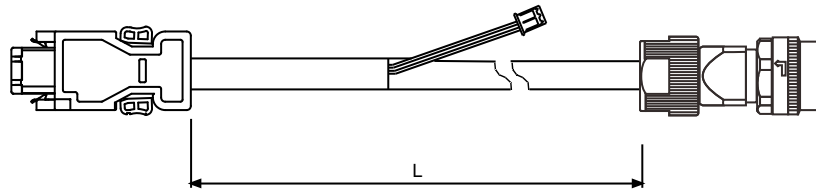

10

Model number of absolute encoder cable	Model number of connector	L	
		mm	inch
ACS3-CAE□A103	CMV1-SP10S	3000 ± 50	118 ± 2
ACS3-CAE□A105	CMV1-SP10S	5000 ± 50	197 ± 2
ACS3-CAE□A110	CMV1-SP10S	10000 ± 100	394 ± 4
ACS3-CAE□A120	CMV1-SP10S	20000 ± 100	787 ± 4

Note: select cables according to the □ in the model number. B represents flexible cables and A represents standard cables.

Connection method:

Caution Follow these instructions when wiring. Incorrect wiring may cause battery explosion.

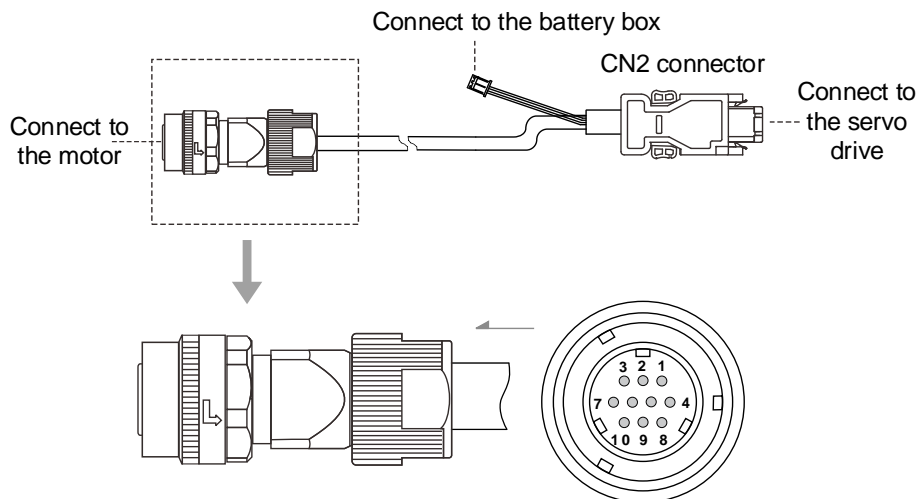

Pin No.	Terminal	Color
1	T+	White
2	T-	White/Red
3	-	-
4	DC+5V	Brown
5	BAT-	Black
6	BAT+	Red
7, 8	-	-
9	GND	Blue
10	Shielding	-

10

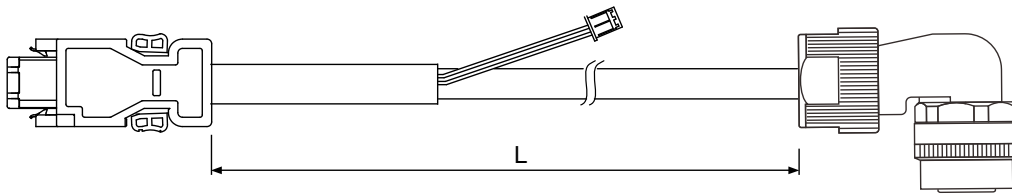

Model number of absolute encoder cable	Model number of connector	L	
		mm	inch
ACS3-CRE□A103	CMV1-AP10S	3000 ± 50	118 ± 2
ACS3-CRE□A105	CMV1-AP10S	5000 ± 50	197 ± 2
ACS3-CRE□A110	CMV1-AP10S	10000 ± 100	394 ± 4
ACS3-CRE□A120	CMV1-AP10S	20000 ± 100	787 ± 4

Note: select cables according to the □ in the model number. B represents flexible cables and A represents standard cables.

Connection method:

Caution Follow these instructions when wiring. Incorrect wiring may cause battery explosion.

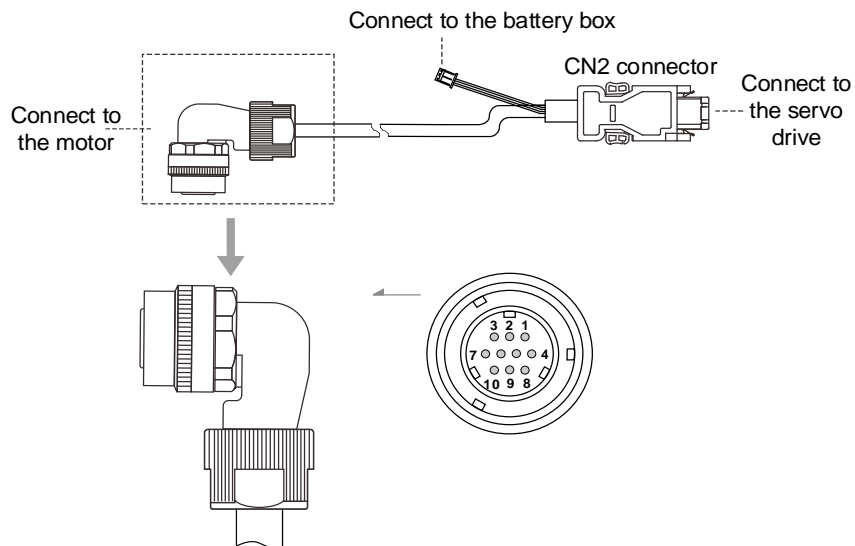

Pin No.	Terminal	Color
1	T+	White
2	T-	White/Red
3	-	-
4	DC+5V	Brown
5	BAT-	Black
6	BAT+	Red
7, 8	-	-
9	GND	Blue
10	Shielding	-

C. CHOGORI connector (220V series F80 models and below)

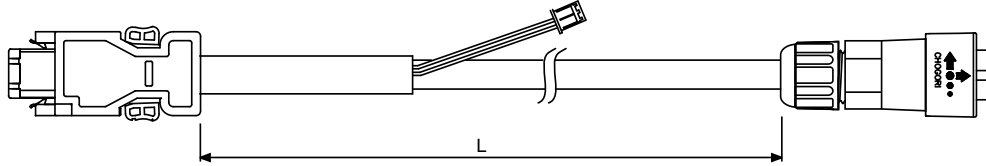

Model number of absolute encoder cable	Model number of connector	L	
		mm	inch
ACS3-CAE□1103	22008231-01	3000 ± 50	118 ± 2
ACS3-CAE□1105	22008231-01	5000 ± 50	197 ± 2
ACS3-CAE□1110	22008231-01	10000 ± 100	394 ± 4
ACS3-CAE□1120	22008231-01	20000 ± 100	787 ± 4

Note: select cables according to the □ in the model number. B represents flexible cables and A represents standard cables.

Connection method:

Caution Follow these instructions when wiring. Incorrect wiring may cause battery explosion.

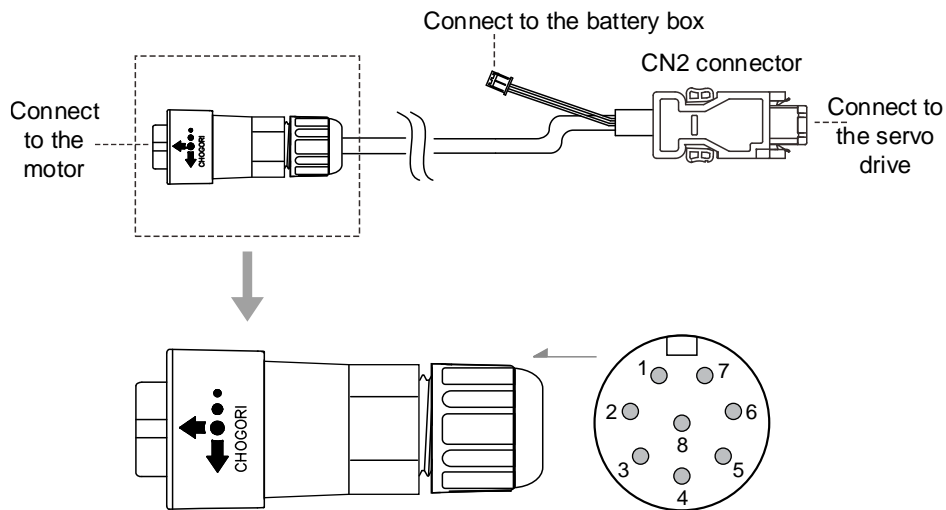

Pin No.	Terminal	Color
1	T+	White
2	T-	White/Red
3	GND	Blue
4	DC+5V	Brown
5	BAT-	Black
6	BAT+	Red
7	-	-
8	Shielding	-

10

D. Bulkhead connector (220V series F80 models and below)

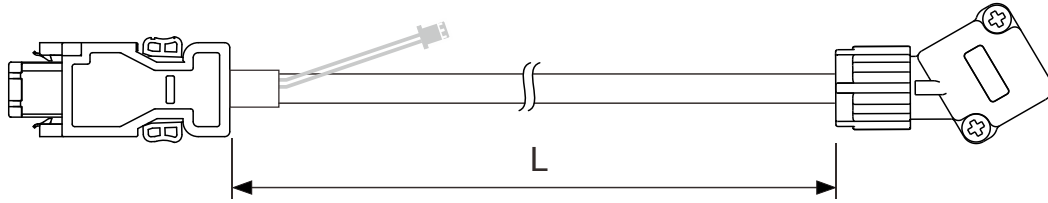

Refer to Section B.5.1 of Appendix B for the cable model number.

Connection method:

Caution Follow these instructions when wiring. Incorrect wiring may cause battery explosion.

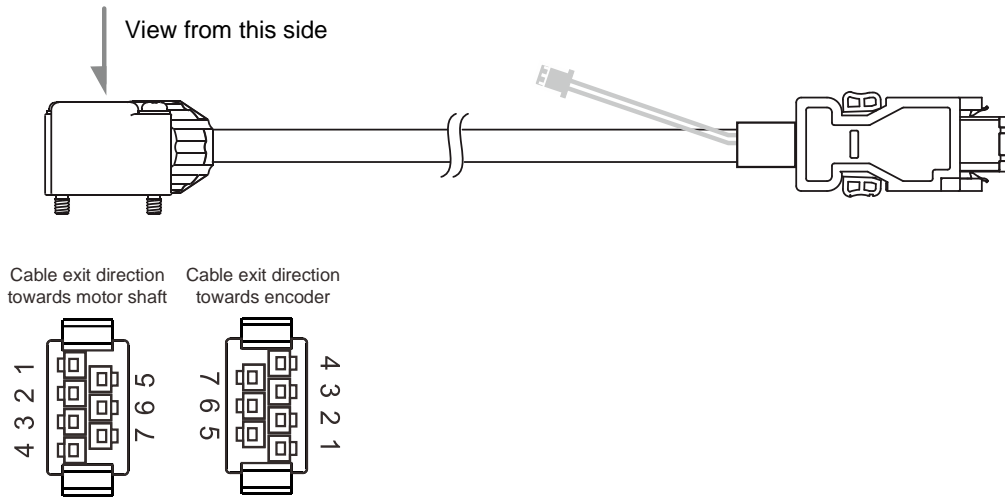

Pin No.	Terminal	Color
1	T+	Blue
2	T-	Purple
3	DC+5V	Red
4	GND	Orange
5	BAT+	Brown
6	BAT-	Black
7	Shielding	-

10.1.4 Battery box cable

Battery box cable for customized wiring

Delta part number: 3864850600

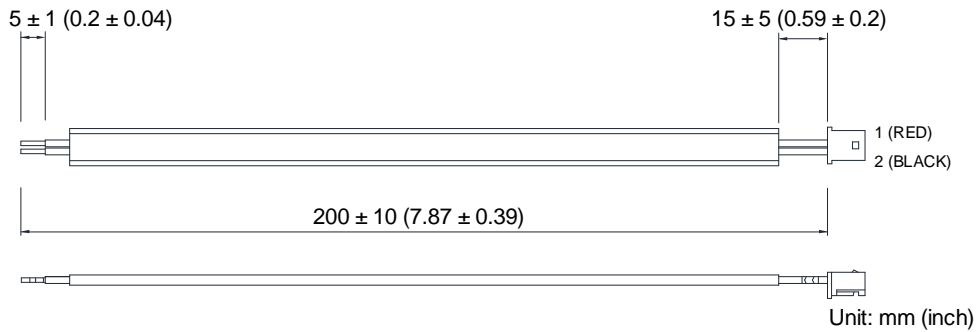

Battery box cable that connects to the encoder cable (male to male)

Delta part number: 3864811901

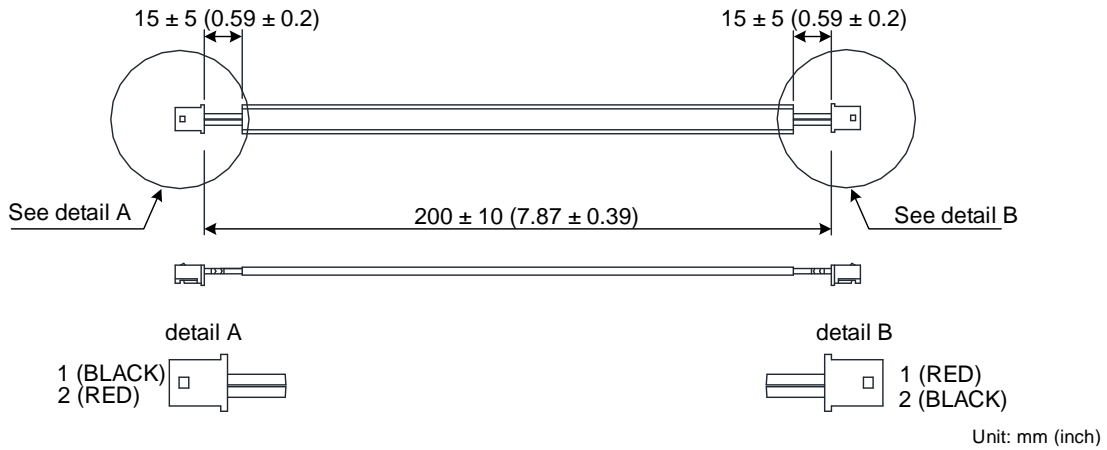

Battery box cable that connects to the encoder cable (male to female)

Delta part number: 3864573700

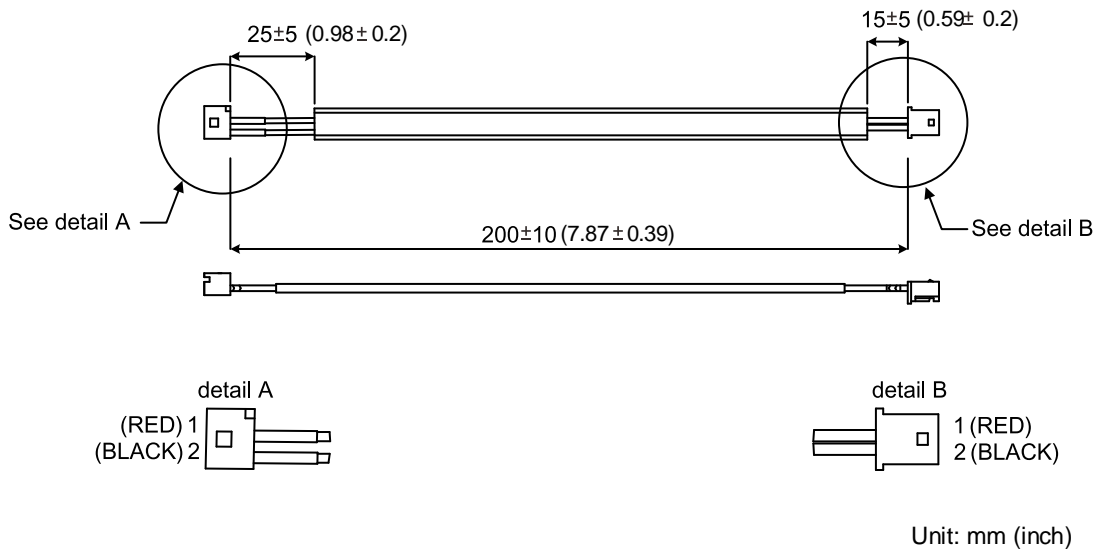

10

10.2 Installation

10.2.1 Installing the battery box in the servo system



- DO NOT connect to Pin 3 and Pin 4 of the servo drive CN2 connector. These pins are for internal use only. Wiring them will cause damage to the internal circuit.
- When an absolute encoder is used, the battery supplies power directly to the encoder, so wiring the battery wires to the CN2 connector of the servo drive is not required.

Single battery box (standard wiring)

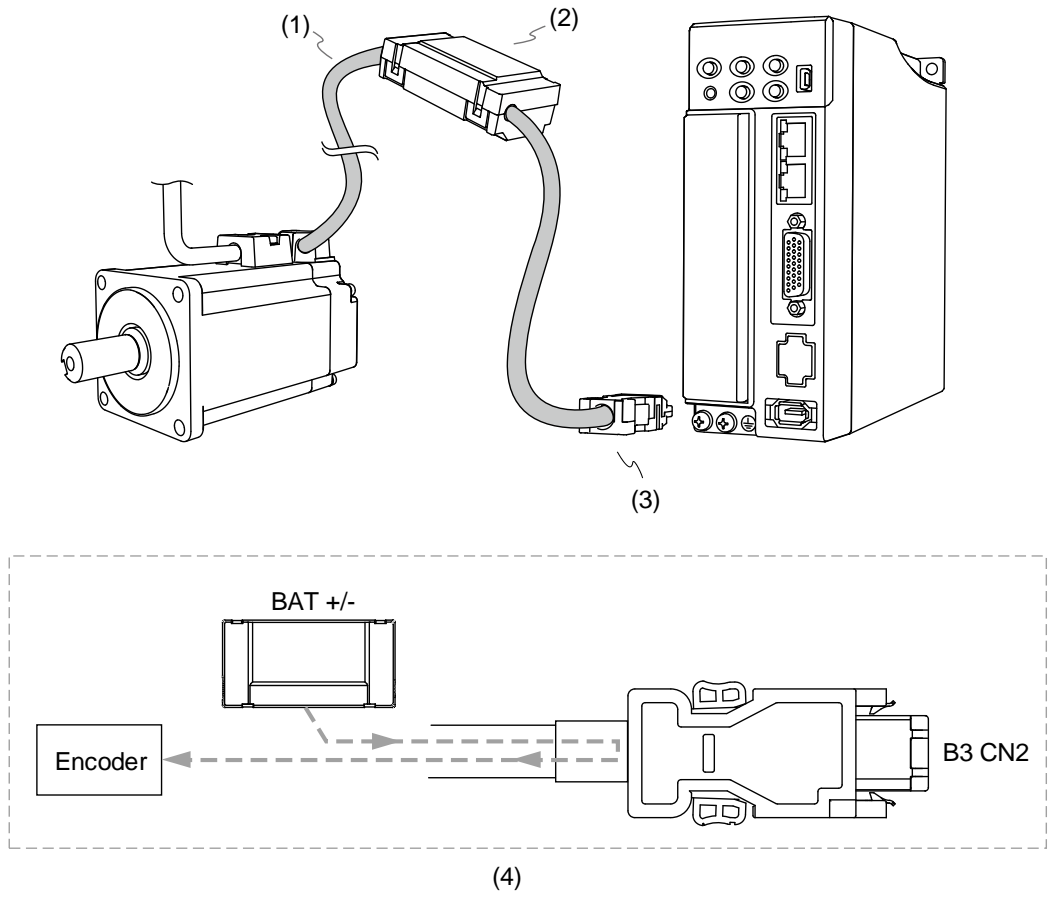

(1) Encoder cable from the motor side; (2) Single battery box;
 (3) CN2 connector; (4) Battery box wiring

Pin assignment of CN2 connector:

Encoder cable connector						CN2 of servo drive		Description
Motor with cables				Motor with bulkhead connectors		Pin No.	Signal	
B3 military	CHOGORI	Standard	Color	Bulkhead	Color			
4	4	7	Brown	3	Red	1	+5V	+5V power supply
9	3	8	Blue	4	Orange	2	GND	Power ground
-	-	-	-	-	-	3	-	DO NOT connect these pins. They are for internal use only.
-	-	-	-	-	-	4	-	
1	1	1	White	1	Blue	5	T+	Serial communication signal (+)
2	2	4	White/Red	2	Purple	6	T-	Serial communication signal (-)
10	8	9	-	7	-	Case	Shielding	Shielding
6	6	2	Red	5	Brown	-	-	+3.6V battery
5	5	5	Black	6	Black	-	-	Battery ground

10

Note: for the wiring details of the absolute encoder connector, refer to Section 3.1.5 Specification for the encoder cable and connector.

Dual battery box (connects to CN2)

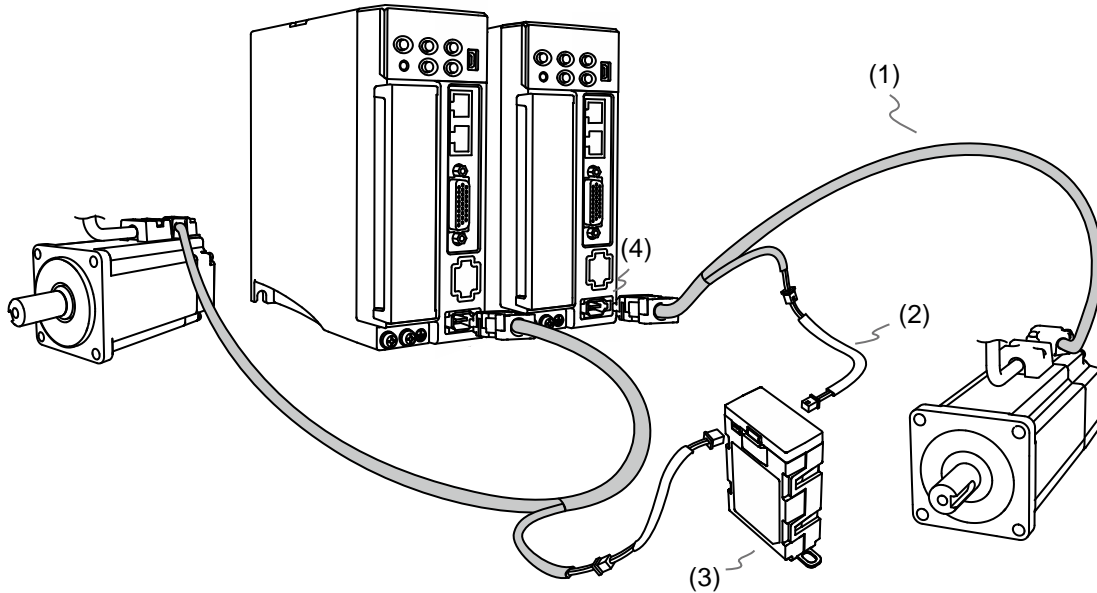

- (1) Absolute encoder cable; (2) Battery box cable (one male end and one female end)
- (3) Dual battery box; (4) CN2 connector

10.2.2 Installing and replacing a battery

Single battery box

10

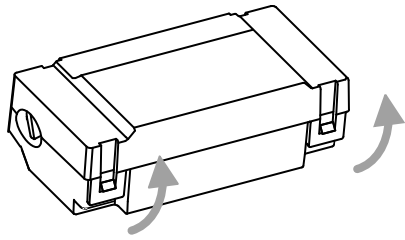

Step 1:
Release the snap-fit tabs on both sides and remove the battery box cover.

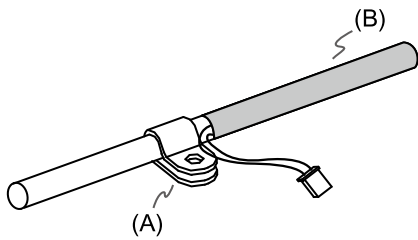

Step 2:
Position the cable clamp to the encoder cable. Note that the cable clamp should be placed close to the heat shrink.
(A) Cable clamp; (B) Heat shrink

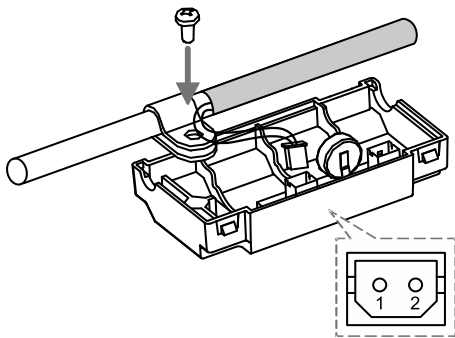

Step 3:
Plug in the battery box cable and tighten the cable clamp screw.

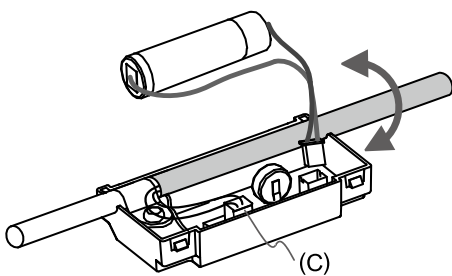

Step 4:
Install a new battery and plug in the battery connection wire.
(C) Replace the battery only when the main power to the servo drive is still on. Do not remove the battery box cable which connects to the servo drive, or else the system may lose data.

(continued)

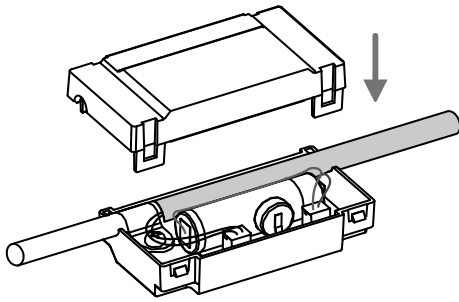

Step 5:
Place the battery connection wire into the box and fit the cover.

10

Note:

To avoid data loss, replace the battery when any of the following circumstances occurs:

1. The servo drive shows AL061 which means the voltage is too low. Refer to Chapter 14 for more information.
2. Use P0.002 (monitoring variable 26h) to check the battery power. When it displays 31, it means the voltage is under 3.1V.

Important

When the voltage is below 2.7V, the motor's position record may be lost if the drive operates under battery power, so you need to re-establish the absolute origin position after installing new batteries. It is suggested that you replace the batteries when the main power to the servo drive is on to avoid loss of absolute position data.

10

10.3 System initialization and operating procedures

10.3.1 System initialization

After the servo system resumes operation, the controller can acquire the motor's current absolute position either with communication (such as RS-485) or DI/DO. Delta's absolute system provides two types of position value for the controller: pulse and PUU.

AL06A occurs when you initialize the absolute system for the first time because the position system has not been established. Clear the alarm by setting up the position system. When insufficient battery power or interruption of battery power causes loss of the position system, AL060 occurs. In the absolute system, the position data is within a specific range. When the number of motor revolutions exceeds the range of -32,768 to +32,767, AL062 occurs. When the PUU position value exceeds the range of -2,147,483,648 to +2,147,483,647, AL289 occurs. In addition to the preceding alarms (enabled by default), you can use P2.070 [Bit 2] to set whether to show AL062 and AL289 if the absolute position system overflows (the number of revolutions exceeds the range of -32,768 to +32,767 the range or the PUU number exceeds the range of -2,147,483,648 to +2,147,483,647). This function is for systems which use incremental commands to operate in a single direction.

P2.070 setting:

1. Establish the absolute origin position. When the position setting is complete, AL06A (or AL060) is automatically cleared. There are two representations for the controller to establish the absolute origin position: pulse number and PUU number. You can establish the absolute origin position with DI/DO, parameters, or the PR homing function.
2. When the system is powered on again, the controller can access the motor's absolute position either with DI/DO or communication. Based on the setting of P2.070, the controller can read the position value in PUU (refer to Section 10.3.3) or the number of revolutions plus the pulse number within a single revolution (refer to Section 10.3.2).

10.3.2 Pulse number

When the motor is running in the clockwise direction, the number of revolutions is defined as a negative value. When the motor runs in the counterclockwise direction, the number of revolutions is defined as a positive value. The range of the countable number of revolutions is between -32768 and +32767. AL062 occurs once the overflow of number of revolutions occurs (which means the number exceeds the range). To clear the alarm, re-establish the absolute origin position. If P2.070 has been set not to show the AL062 alarm, then the system ignores the overflow of number of revolutions.

If the motor is operating in the counterclockwise direction and the number of revolutions reaches +32,767, the value jumps to -32,768 once the motor reaches the target position in the next turn, and the value keeps increasing from -32,768 to +32,767. If the motor is operating in the clockwise direction and the number of revolutions reaches -32,768, the value jumps to +32,767 once the motor reaches the target position in the next turn, and the value keeps decreasing from +32767 to -32768.

In addition, there are 16,777,216 pulses (0 to 16,777,215) in one revolution. Pay attention to the motor's running direction. You can read the number of revolutions and the pulse number within a single turn with either communication or DI/DO.

Total pulse number = m (number of revolutions) x 16,777,216 + pulse number within a single turn (0 to 16,777,215).

The conversions between pulse number and PUU are as follows:

When P1.001.Z = 0: the PUU number when power on = pulse number x $\frac{P1.045}{P1.044}$ + P6.001.

When P1.001.Z = 1: the PUU number when power on = (-1) x pulse number x $\frac{P1.045}{P1.044}$ + P6.001.

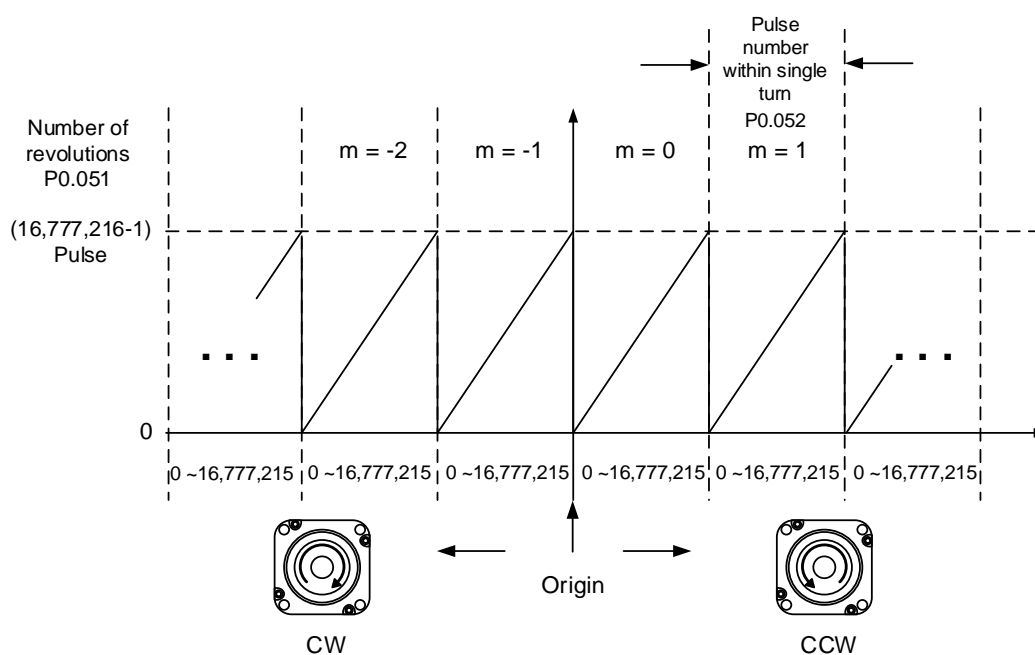

Figure 10.3.2.1 Absolute position for pulse number

10

10.3.3 PUU number

The PUU number is a 32-bit absolute position data with a positive or negative sign. When the motor is running in the forward direction, the PUU number increases; when the motor is running in the reverse direction, the PUU number decreases. The motor operation direction is defined by P1.001.Z; operation in the forward direction does not necessarily mean the motor is operating in the clockwise direction.

If the motor keeps running in the same direction and the number of revolutions exceeds the range of -32768 to +32767, the servo drive generates AL062. If the motor's PUU number exceeds the range of -2147483648 to +2147483647, the servo drive generates AL289 (Position counter overflows). When an overflow issue of the absolute encoder (AL062 or AL289) occurs, re-establish the absolute origin position to clear the alarm. You can also set P2.070 to determine whether the servo drive generates the alarms AL062 and AL289 when an overflow occurs. If the motor is running in the forward direction and the absolute position data reaches +2147483647 PUU, the value jumps to -2147483648 in the next turn, and the value keeps increasing from -2147483648 to 2147483647. The value changes the other way when the motor is running in the reverse direction. See the following examples:

Example 1:

When P1.044 = 16777216 and P1.045 = 100000, the motor needs 100,000 PUU to run one revolution. $2147483647 \div 100000 \approx 21474.8$, so once the motor runs over 21,474.8 (< 32767) revolutions in the positive direction, AL289 occurs.

Example 2:

When P1.044 = 16777216 and P1.045 = 10000, the motor needs 10,000 PUU to run one revolution. $2147483647 \div 10000 \approx 214748.3$, so once the motor runs over 32,767 (< 214748.3) revolutions in the positive direction, AL062 occurs.

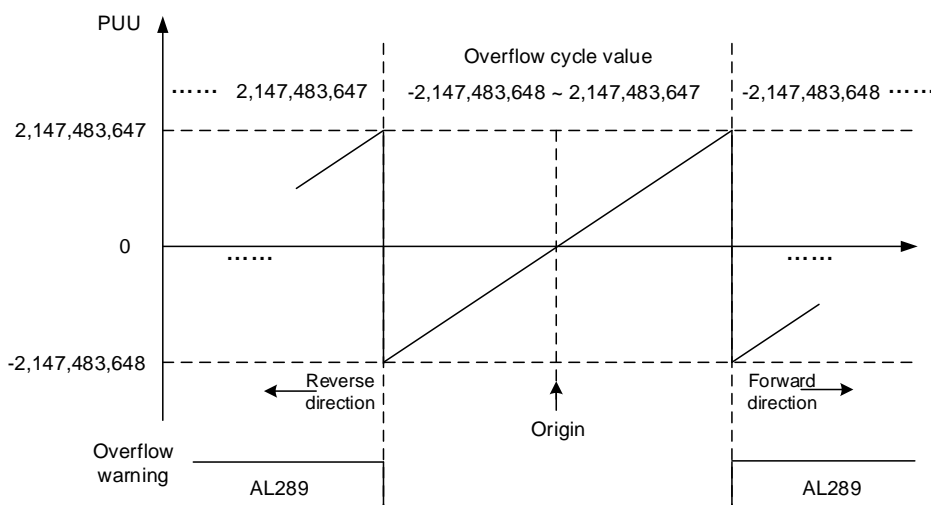

Figure 10.3.3.1 Absolute position for PUU number

Note: after the absolute origin position is established, any change to P1.001.Z or E-Gear ratio (P1.044 and P1.045) changes the original setting of the absolute origin position. If these parameters are changed, re-establish the absolute origin position.

10.3.4 Establish the absolute origin position

When the absolute position is lost, the servo drive provides three methods to establish the absolute origin position: DI/DO, parameter setting, or the PR homing function. The following provides more details for each method.

10.3.4.1 Establishing the absolute origin position with DI/DO

When the servo system is controlled by the controller, you can establish the absolute origin position with DI/DO. Once the absolute position is established, the pulse number is reset to 0 and the PUU number is reset to the value of P6.001. Refer to the following diagram for detailed descriptions.

Description:

1. When the controller triggers DI.ABSE, it has to wait for T_s before proceeding to the next step.
2. After reaching T_s , the controller starts to establish the absolute origin position. When DI.ABSC is triggered and remains on for T_Q , the pulse number is reset to 0 and the PUU number is reset to the value of P6.001.

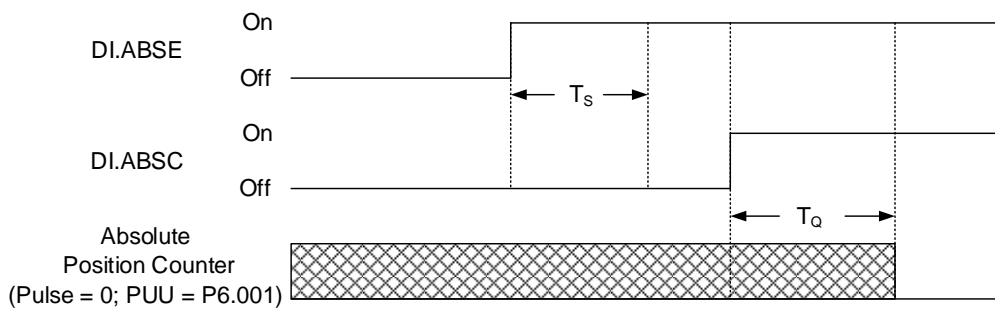

Figure 10.3.4.1.1 Timing diagram for establishing the absolute origin position with DI/DO

The following table describes the T_s and T_Q delay time after DI.ABSE and DI.ABSC are switched to On.

	T_s (ms)	T_Q (ms)
Min.	P2.009 + 2	
Max.	P2.009 + 10	

10

10.3.4.2 Establishing the absolute origin position with parameters

Set P2.071 to 1 to establish the absolute origin position through the panel or with communication. Since P2.071 is write-protected by P2.008, you must set P2.008 to 271 first. In other words, the sequence is: set P2.008 to 271 to 1, and then set P2.071 to 1. As soon as P2.071 is set to 1, the absolute position system resets.

10.3.4.3 Establishing the absolute origin position with the PR homing function

You can use the 11 homing modes in the PR mode to establish the absolute origin position. For more details, refer to Section 7.1.3.1 Homing methods.

10.3.5 Reading the absolute position

10.3.5.1 Establishing the absolute origin position with DI/DO

Set P2.070 [Bit 0] to 0 so that you can read the PUU number with DI/DO. See the following descriptions.

Bit 79 - Bit 64	Bit 63 - Bit 32	Bit 31 - Bit 16	Bit 15 - Bit 0
Check Sum	Encoder PUU -2147483648 to +2147483647	0	Encoder status (P0.050)

Set P2.070 [Bit 0] to 1 so that you can read the pulse number with DI/DO. See the following descriptions.

Bit 79 - Bit 64	Bit 63 - Bit 32	Bit 31 - Bit 16	Bit 15 - Bit 0
Check Sum	Encoder pulse number within one revolution 0 to 16,777,215 (= 16,777,216 - 1)	Number of encoder revolution -32768 to +32767	Encoder status (P0.050)

Description:

$$\text{Check Sum} = ((((((\text{WORD}_0 + 0xA700) \text{ XOR } \text{WORD}_1) + 0x605A) \text{ XOR } \text{WORD}_2) + 0x30A5) \text{ XOR } \text{WORD}_3) + 0x5A06)$$

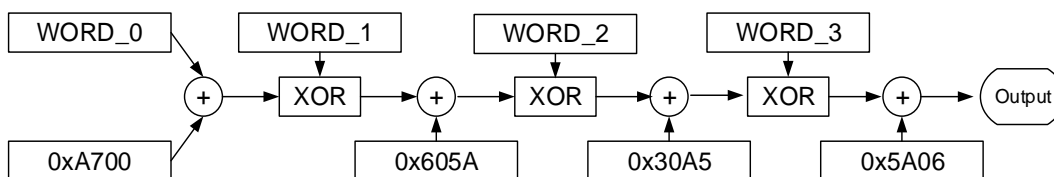

Note:

1. This algorithm has no positive or negative sign.
2. 0xA700, 0x605A, 0x30A5, and 0x5A06 are constants in hexadecimal format.
3. WORD_0: encoder status (Bit 15 - 0)
 WORD_1: number of encoder revolution (Bit 31 - 16)
 WORD_2: encoder pulse number (Bit 47 - 32)
 WORD_3: encoder pulse number (Bit 63 - 48)

You can set P2.070 to read the position value in units of pulse or PUU with DI/DO. See the following timing diagram.

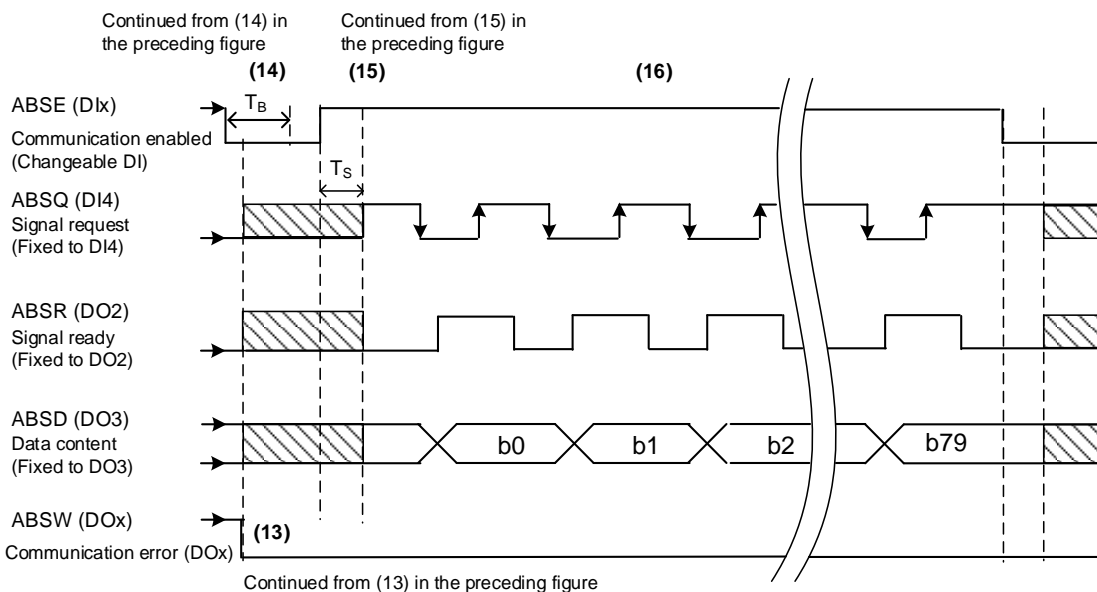
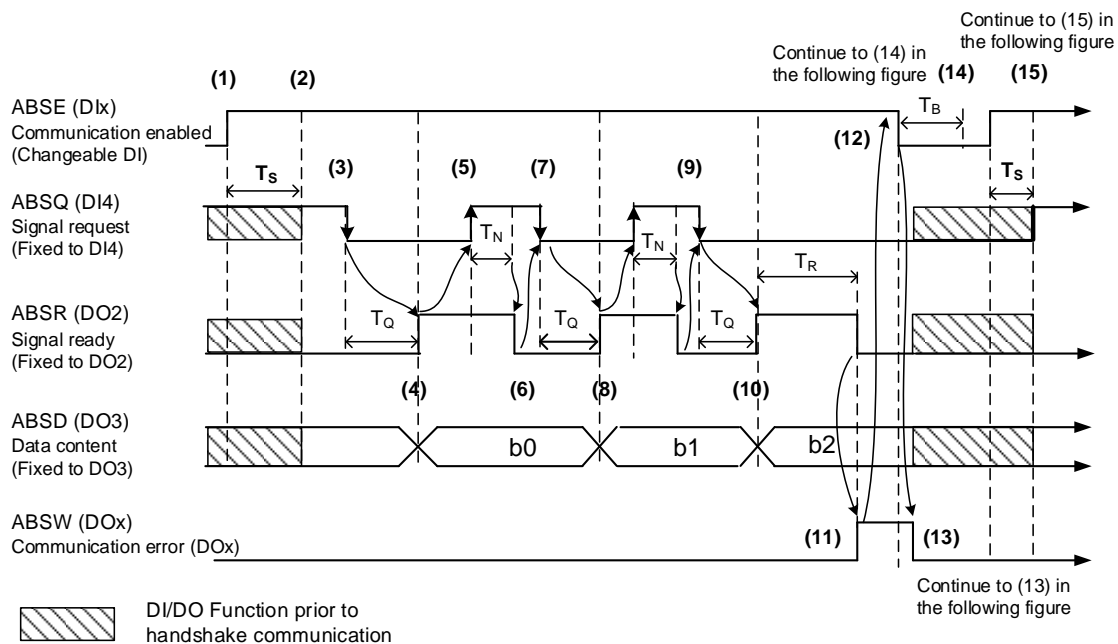

Figure 10.3.5.1.1 Timing diagram for reading the absolute position with DI/DO

The following table describes the delay time when reading the absolute position with DI/DO.

	T_R (ms)	T_S (ms)	T_Q (ms)	T_N (ms)	T_B (ms)
Min.	-	P2.009 + 2			
Max.	200	P2.009 + 10			

Descriptions:

- (1) When the handshake communication starts, the ABSE signal is triggered.
- (2) After the T_s delay time (make sure the ABSE signal is On), the functions for DI4, DO2, and DO3 are switched to ABSQ, ABSR, and ABSD, respectively. If DI4 was in the high-level state before, it remains in the high-level state when switched to ABSQ (logic high-level signal). DI4, DO2, and DO3 are dual-function DI/DOs, which means the set functions for DI4, DO2, and DO3 share the same DI/DOs with ABSQ, ABSR, and ABSD. Before, during, or after the signal handshake, pay special attention when switching their functions. To set these three DI/DOs as single function, set them to 0 before setting the functions.
- (3) If DI4 was in the high-level state and switched to ABSQ after the T_s delay time, when the controller resets this signal to low level, the new signal is interpreted as the data access command.
- (4) After the T_Q time, the handshake data is ready and the absolute position is sent to ABSD. Now the servo drive triggers the ABSR signal and the controller can access the data. If the controller cannot detect the ABSR status while it is changing to high level after the maximum T_Q time, there may be a communication error such as communication cable disconnection.
- (5) Once the ABSR signal is set to high level, the controller accesses the data, and the ABSQ signal is set to high level to notify the servo drive that data was read.
- (6) When ABSQ is at high level, ABSR is set to low level after the T_N time in order to send the data for the next bit communication.
- (7) When ABSR is at low level, ABSQ is also set to low level and the servo drive needs to send the data for the next bit communication.
- (8) Repeat steps 3 and 4. Send the absolute position to ABSD for the next bit communication.
- (9) Repeat steps 5 to 7. The controller has read and received the data.
- (10) The third bit data is ready.
- (11) After the T_R waiting time, if the controller has not read the data and triggered the ABSQ signal, the servo drive sends the ABSW signal (communication error) and stops the handshake communication.
- (12) When the controller receives the communication error signal, it sets ABSE to low level and prepares to restart the handshake communication.
- (13) ABSW resumes to low level after the servo drive receives the ABSE signal.
- (14) The controller resumes communication after the T_B time.
- (15) Repeat step 1.
- (16) If no error occurs, the controller completes 80 bits (0 - 79) of the handshake communication with the servo drive. DI4, DO2, and DO3 then resume their original functions.

Note: if ABSE is set to low level first and then changed to high level, but ABSW does not resume to high level and the alarm remains on, it means some other errors exist. Check for the following possible warnings: absolute position lost, low battery voltage level, or absolute position overflows. Restart a new communication cycle after those errors have been cleared.

10.3.5.2 Reading the absolute position with communication

You can access the data of the absolute encoder through two communication methods: instant access or register access.

Instant access

Instant access refers to reading the motor's feedback position as soon as power is supplied to the servo. When you set the status monitoring register 1 to the motor's feedback pulse number (P0.017 = 0), you can access the motor's current position by reading P0.009.

Register access

Register access means the motor's position is temporarily stored in the register and the read value does not change with the motor's movement. Once you set P0.049 with communication, the encoder status and motor absolute position (number of revolutions), and pulse number (or PUU) are stored in P0.050, P0.051, and P0.052 respectively. You can set to read the value in the unit of pulse or PUU with P2.070 [Bit 1].

- When P0.049 is set to 1, the drive does not clear the position error when reading the position value.
- When P0.049 is set to 2, the drive clears the error at the same time when reading the position value. After the motor is enabled, it moves slightly forward and backward to correct its position even it is stopped. To avoid the difference between the actual and read motor positions, set P0.049 to 2 to have the motor's actual position updated to the servo drive, which clears the position error.

For example, the motor's current position is 20000, but it varies between 19999 and 20001. If you send the command to read the motor's position when it stops at 20001, the read value is 20001. Meanwhile, 20001 is updated to the servo drive, meaning the position error is cleared. If the servo drive does not update the read position, a command error occurs.

- After all positions are updated in P0.050 - P0.052, P0.049 is automatically reset to 0. At that point, the controller can access the values of P0.050 - P0.052.
- P0.050 shows the status of the absolute encoder. When the status shows "absolute position lost" or "overflow of number of revolutions", it means the read absolute position is invalid. In this case, you must re-establish the absolute origin position.

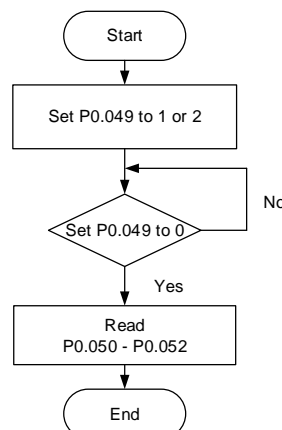

10.4 Parameters, DI/DO, and alarms related to absolute function

Relevant parameters (refer to Chapter 8 for detailed information):

Parameter	Function
P0.002	Drive status
P0.049	Update encoder absolute position
P0.050	Absolute position system status
P0.051	Encoder absolute position - number of revolutions
P0.052	Encoder absolute position - pulse number or PUU within single turn
P2.069	Absolute encoder
P2.070	Read data selection
P2.071	Absolute position homing

Relevant DI/DO (refer to Chapter 8 for detailed information):

Setting value	DI name	Setting value	DO name
0x1D	ABSE	When DI.ABSE is on, DO.ABSR triggered by DO2 will replace the DO2 assigned by P2.019.	ABSR always output by DO2
When DI.ABSE is on, the DI.ABSQ from DI4 replaces the DI4 function from P2.013.	ABSQ always input by DI4	When DI.ABSE is on, DO.ABSD triggered by DO3 will replace the DO3 assigned by P2.020.	ABSD always output by DO3
0x1F	ABSC	0x0D	ABSW

Relevant alarms (refer to Chapter 14 for detailed information):

Display	Alarm name
AL060	Absolute position is lost
AL061	Encoder undervoltage
AL062	Number of revolutions of the absolute encoder overflows (issued by encoder)
AL069	Wrong motor type
AL072	Encoder overspeed
AL073	Encoder memory error
AL074	Encoder single-turn absolute position is in error
AL075	Encoder absolute number of revolutions is in error
AL077	Encoder internal error
AL079	Encoder parameter setting incomplete
AL07B	Encoder memory is busy
AL07C	Command to clear the absolute position is issued when the motor speed is over 200 rpm
AL07D	Motor stops operating when servo drive power is cycled before AL07C is cleared
AL07E	Error occurs when the encoder clears the procedure
AL289	Position counter overflows