

Specifications Appendix

A

A.1	ASDA-B3 series servo drive	A-3
A.1.1	Specifications of the ASDA-B3 servo drive	A-3
A.1.1.1	220V series	A-3
A.1.1.2	400V series	A-6
A.1.2	Dimensions of the servo drive	A-9
A.1.2.1	220V series	A-9
A.1.2.2	400V series	A-11
A.2	ECM-B3 series servo motor	A-12
A.2.1	ECM-B3 series servo motor	A-14
A.2.1.1	220V series	A-14
	Motor frame size: 80 mm and below (low & medium inertia)	A-14
	Motor frame size: 80 mm and below (high inertia)	A-16
	Motor frame size: 100 mm (medium inertia)	A-18
	Motor frame size: 130 mm (medium & high inertia)	A-20
	Motor frame size: 180 mm (medium inertia)	A-22
A.2.1.2	400V series	A-24
	Motor frame size: 80 mm and below (medium inertia)	A-24
	Motor frame size: 100 mm (medium inertia)	A-26
	Motor frame size: 130 mm (medium & high inertia)	A-28
	Motor frame size: 180 mm (medium inertia)	A-30
A.2.2	Torque features (T-N curves) of the B3 motors	A-32
A.2.2.1	220V series	A-32
	Motor frame size: 80 mm and below	A-32
	Motor frame size: 100 mm	A-34
	Motor frame size: 130 mm	A-35
	Motor frame size: 180 mm	A-36
A.2.2.2	400V series	A-37
	Motor frame size: 80 mm and below	A-37
	Motor frame size: 100 mm	A-37
	Motor frame size: 130 mm	A-38
	Motor frame size: 180 mm	A-39
A.2.3	Power derating curves of the B3 motors	A-40
A.2.4	Overload features	A-41



- A.2.5 Dimensions of ECM-B3 series servo motor A-43
 - A.2.5.1 220V series A-43
 - Motor frame size: 80 mm and below, with cables (low & medium & high inertia)..... A-43
 - Motor frame size: 80 mm and below, with bulkhead connectors (low & medium & high inertia) A-44
 - Motor frame size: 100 mm (medium inertia) A-45
 - Motor frame size: 130 mm (medium & high inertia)..... A-46
 - Motor frame size: 180 mm (medium inertia) A-47
 - A.2.5.2 400V series A-48
 - Motor frame size: 80 mm and below, with cables (medium inertia) A-48
 - Motor frame size: 100 mm (medium inertia) A-49
 - Motor frame size: 130 mm (medium & high inertia)..... A-50
 - Motor frame size: 180 mm (medium inertia) A-51
- A.3 ECM-A3 series servo motor A-52
 - A.3.1 ECM-A3L low inertia series servo motor A-54
 - A.3.2 ECM-A3H high inertia series servo motor A-56
 - A.3.3 Torque features (T-N curves) of the A3 motors A-58
 - A.3.4 Overload features A-60
 - A.3.5 Dimensions of ECM-A3L / A3H series servo motor..... A-61

A.1 ASDA-B3 series servo drive

A.1.1 Specifications of the ASDA-B3 servo drive

A.1.1.1 220V series

ASDA-B3		100 W	200 W	400 W	750 W	1 kW	1.5 kW	2 kW	3 kW	
		01	02	04	07	10	15	20	30	
Main circuit power	Phase / Voltage	Single- / Three-phase 220 V _{AC}						Three-phase 220 V _{AC}		
	Permissible voltage	Single- / Three-phase 200 - 230 V _{AC} , -15% to +10%						Three-phase 200 - 230 V _{AC} , -15% to +10%		
	Input current (3PH) (Arms)	0.88	1.29	2.04	3.52	5.72	6.33	7.6	10.3	
	Input current (1PH) (Arms)	1.47	2.35	3.74	6.47	10.4	11.7	-	-	
	Inrush current (220V) (Arms)	5.50	5.50	5.50	5.50	12.45	12.45	12.45	12.45	
Control circuit power	Phase / Voltage	Single-phase 220 V _{AC}								
	Permissible voltage	Single-phase 200 - 230 V _{AC} , -15% to +10%								
	Input current (220V) (Arms)	0.13	0.13	0.13	0.13	0.15	0.15	0.17	0.17	
	Inrush current (220V) (Arms)	24.89	24.89	24.89	24.89	24.89	24.89	24.89	24.89	
Continuous output current (Arms)		0.9	1.55	2.65	5.1	7.3	8.3	13.4	19.4	
Max. instantaneous output current (Arms)		3.88	7.07	10.6	14.14	21.21	24.3	38.3	53.03	
Regenerative resistor	Built-in	Resistance (Ohm)	-	-	100	100	100	100	20	20
		Capacity (Watt)	-	-	40	40	40	40	80	80
	External	Minimum allowable resistance (Ohm)	60	60	60	60	30	30	15	15
Cooling method		Air convection cooling				Fan cooling				





Note:

1. The input current is the actual value measured when the servo drive is under the rated output condition with an AC power supply at 220V.
2. When an electronic transformer is used, the output of the servo drive will be derated to 70%.

A

Specification table

Item		Specification	
Servo drive resolution		24-bit (16777216 p/rev)	
Main circuit control		SVPWM control	
Tuning mode		Manual / Auto	
Position control mode	Pulse type	Pulse + symbol, CCW pulse + CW pulse, A phase + B phase	
	Max. input pulse frequency	Pulse + symbol: 4 Mpps CCW pulse + CW pulse: 4 Mpps A phase + B phase: single-phase 2 Mpps Open collector: 200 Kpps	
	Command source	External pulse / Register	
	Smoothing method	Low-pass filter; S-curve filter; moving filter	
	E-Gear ratio	E-Gear ratio: N/M times; $1 \leq N/M \leq 262144$	
	Torque limit	Parameter settings	
	Feedforward compensation	Parameter settings	
Speed control mode	Analog command input	Voltage range	-10 to +10 V _{DC}
		Resolution	12-bit
		Input impedance	1 MΩ
		Time constant	25 μs
	Speed control range ^{*1}	1 : 6000	
	Command source	External analog command / Register	
	Smoothing method	Low-pass filter; S-curve filter; moving filter	
	Torque limit	Parameter settings / Analog input	
	Bandwidth	Maximum 3.1 kHz	
	Speed calibration ratio ^{*2}	Max. ±0.01% at 0% to 100% load fluctuation Max. ±0.01% at ±10% power fluctuation Max. ±0.01% at ambient temperature between 0°C to 50°C (32°F to 122°F)	
Torque control mode	Analog command input	Voltage range	-10 to +10 V _{DC}
		Input impedance	1 MΩ
		Time constant	25 μs
	Command source	External analog command / Register	
	Smoothing method	Low-pass filter	
	Speed limit	Parameter settings / Analog input	
Analog monitor output	Monitor signal can be set by parameters (voltage output range: ±8V); resolution: 10-bit		
Digital input	-L models: 9 DI points; -M, -F, and -E models: 4 DI points; -P models: 6 DI points. Refer to Chapter 8 for the function settings.		

Item	Specification	
Digital output	-L models: 6 DO points; -M, -F, and -E models: 2 DO points; -P models: 3 DO points. Refer to Chapter 8 for the function settings.	
Protection function	Overcurrent, Overvoltage, Undervoltage, Overheat, Regeneration error, Overload, Excessive speed deviation, Excessive position deviation, CN2 communication failure, Emergency stop, Positive / negative limit error, Serial communication error, RST power error, Serial communication timeout, Short-circuit protection for terminals U, V, W.	
Communication interface	RS-485 / Mini USB / CANopen / DMCNET / EtherCAT / PROFINET	
Environment	Installation site	Indoors (avoid direct sunlight), no corrosive vapor (avoid fumes, flammable gases, and dust)
	Altitude	Less than 2,000 m above sea level
	Atmospheric pressure	86 kPa - 106 kPa
	Ambient temperature	0°C to 55°C (32°F to 131°F) (If the ambient temperature is above 45°C (113°F), forced cooling is required)
	Storage temperature	-20°C to +65°C (-4°F to +176°F)
	Humidity	0 - 90% RH (non-condensing)
	Vibration	10 Hz to 57 Hz: 0.075 mm amplitude; 58 Hz to 150 Hz: 1 G
	IP rating	IP20
	Power system	TN system ^{*3*4}
	Approvals ^{*5}	IEC/EN/UL 61800-5-1    

Note:

1. Within the rated load, the speed ratio is: the minimum speed (smooth operation) / rated speed.
2. Within the rated speed, the speed calibration ratio is: (rotation speed with no load - rotation speed with full load) / rated speed.
3. TN system: the neutral point of the power system connects directly to the ground. The exposed metal components connect to the ground through the protective ground conductor.
4. Use a single-phase three-wire power system for models using a single-phase power supply.
5. Only the B3A series has received the TÜV Functional Safety certification.
6. Go to [Delta's website](#) for the certificates.

A

A.1.1.2 400V series

A

ASDA-B3		1 kW	1.5 kW	2 kW	3 kW	4.5 kW	5.5 kW	7.5 kW	
		10	15	20	30	45	55	75	
Main circuit power	Phase / Voltage	Three-phase 400 V _{AC}							
	Permissible voltage	Three-phase 380 - 440 V _{AC} , -10% to +10%							
	Input current (400V) (Arms)	2.91	3.52	5.06	6.14	12	14.5	20	
	Inrush current (400V) (Arms)	5.66	5.66	5.66	5.66	37.72	37.72	37.72	
Control circuit power	Phase / Voltage	Single-phase 400 V _{AC}							
	Permissible voltage	Single-phase 380 - 440 V _{AC} , -10% to +10%							
	Input current (400V) (Arms)	0.1	0.1	0.1	0.1	0.13	0.13	0.13	
	Inrush current (400V) (Arms)	37.72	37.72	37.72	37.72	37.72	37.72	37.72	
Continuous output current (Arms)		3.37	4.09	5.96	9.11	13.30	15.34	22.11	
Max. instantaneous output current (Arms)		7.07	10.6	18.98	27.33	35.35	49.29	53.03	
Regenerative resistor	Built-in	Resistance (Ohm)	100	100	50	50	35	35	35
		Capacity (Watt)	80	80	80	80	100	100	100
	External	Minimum allowable resistance (Ohm)	80	60	45	40	35	25	25
Cooling method		Fan cooling							

Note: the input current is the actual value measured when the servo drive is under the rated output condition with an AC power supply at 400V.

Specification table

Item		Specification	
Servo drive resolution		24-bit (16777216 p/rev)	
Main circuit control		SVPWM control	
Tuning mode		Manual / Auto	
Position control mode	Pulse type	Pulse + symbol, CCW pulse + CW pulse, A phase + B phase	
	Max. input pulse frequency	Pulse + symbol: 4 Mpps CCW pulse + CW pulse: 4 Mpps A phase + B phase: single-phase 2 Mpps Open collector: 200 Kpps	
	Command source	External pulse / Register	
	Smoothing method	Low-pass filter; S-curve filter; moving filter	
	E-Gear ratio	E-Gear ratio: N/M times; $1 \leq N/M \leq 262144$	
	Torque limit	Parameter settings	
	Feedforward compensation	Parameter settings	
Speed control mode	Analog command input	Voltage range	-10 to +10 V _{DC}
		Resolution	12-bit
		Input impedance	1 MΩ
		Time constant	25 μs
	Speed control range ^{*1}	1 : 6000	
	Command source	External analog command / Register	
	Smoothing method	Low-pass filter; S-curve filter; moving filter	
	Torque limit	Parameter settings / Analog input	
	Bandwidth	Maximum 3.1 kHz	
	Speed calibration ratio ^{*2}	Max., ±0.01% at 0% to 100% load fluctuation Max. ±0.01% at ±10% power fluctuation Max. ±0.01% at ambient temperature between 0°C to 50°C (32°F to 122°F)	
Torque control mode	Analog command input	Voltage range	-10 to +10 V _{DC}
		Input impedance	1 MΩ
		Time constant	25 μs
	Command source	External analog command / Register	
	Smoothing method	Low-pass filter	
Speed limit	Parameter settings / Analog input		
Analog monitor output	Monitor signal can be set by parameters (voltage output range: ±8V); resolution: 10-bit		
Digital input	-L models: 9 DI points; -M, -F, and -E models: 4 DI points; -P models: 6 DI points. Refer to Chapter 8 for the function settings.		

A

A

Item		Specification
Digital output		-L models: 6 DO points; -M, -F, and -E models: 2 DO points; -P models: 3 DO points. Refer to Chapter 8 for the function settings.
Protection function		Overcurrent, Overvoltage, Undervoltage, Overheat, Regeneration error, Overload, Excessive speed deviation, Excessive position deviation, CN2 communication failure, Emergency stop, Positive / negative limit error, Serial communication error, RST power error, Serial communication timeout, Short-circuit protection for terminals U, V, W.
Communication interface		RS-485 / Mini USB / CANopen / DMCNET / EtherCAT / PROFINET
Environment	Installation site	Indoors (avoid direct sunlight), no corrosive vapor (avoid fumes, flammable gases, and dust)
	Altitude	Less than 2,000 m above sea level
	Atmospheric pressure	86 kPa - 106 kPa
	Ambient temperature	0°C to 55°C (32°F to 131°F) (If the ambient temperature is above 45°C (113°F), forced cooling is required and the average load rate should be 80% or less)
	Storage temperature	-20°C to +65°C (-4°F to +176°F)
	Humidity	0 - 90% RH (non-condensing)
	Vibration	10 Hz to 57 Hz: 0.075 mm amplitude; 58 Hz to 150 Hz: 1 G
	IP rating	IP20
	Power system	TN system ³
	Approvals ^{4*5}	IEC/EN 61800-5-1 

Note:

1. Within the rated load, the speed ratio is: the minimum speed (smooth operation) / rated speed.
2. Within the rated speed, the speed calibration ratio is: (rotation speed with no load - rotation speed with full load) / rated speed.
3. TN system: the neutral point of the power system connects directly to the ground. The exposed metal components connect to the ground through the protective ground conductor.
4. TÜV certification application is in progress.
5. TÜV Functional Safety certification application for the B3A series is in progress.
6. Go to [Delta's website](#) for the certificates.

A.1.2 Dimensions of the servo drive

A.1.2.1 220V series

100 W / 200 W / 400 W

A

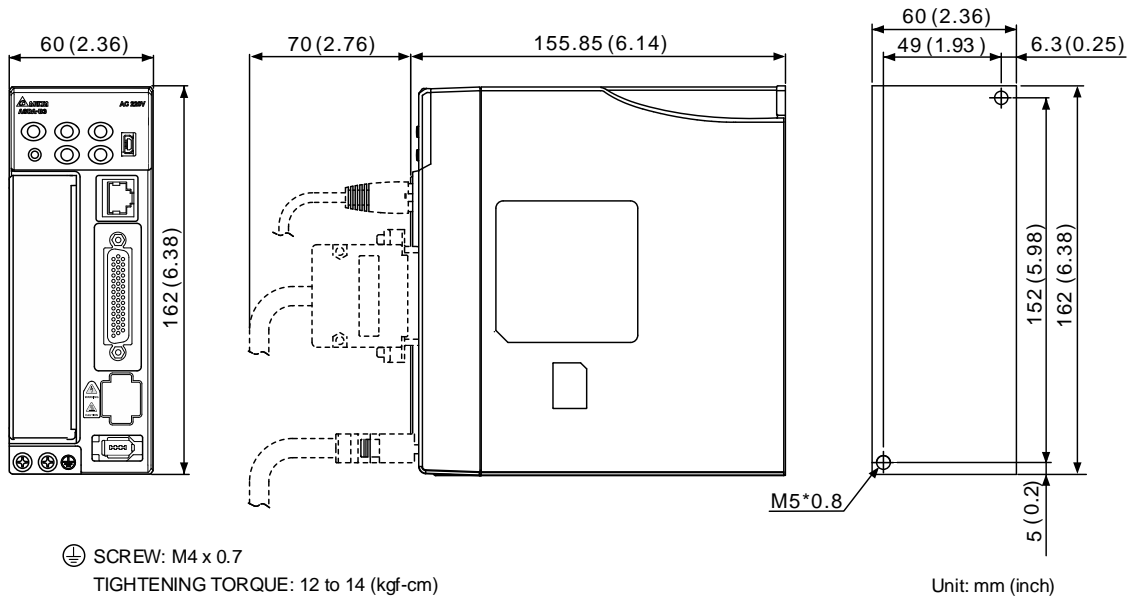

Weight	0.9 kg (1.98 lb)
--------	------------------

750 W

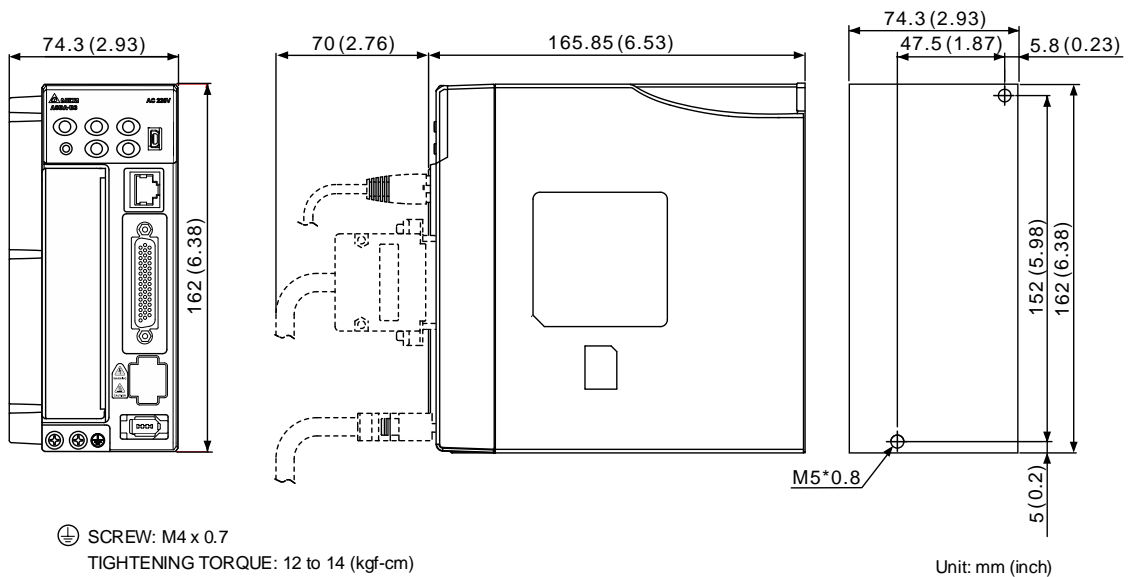

Weight	1.2 kg (2.64 lb)
--------	------------------

1 kW / 1.5 kW

A

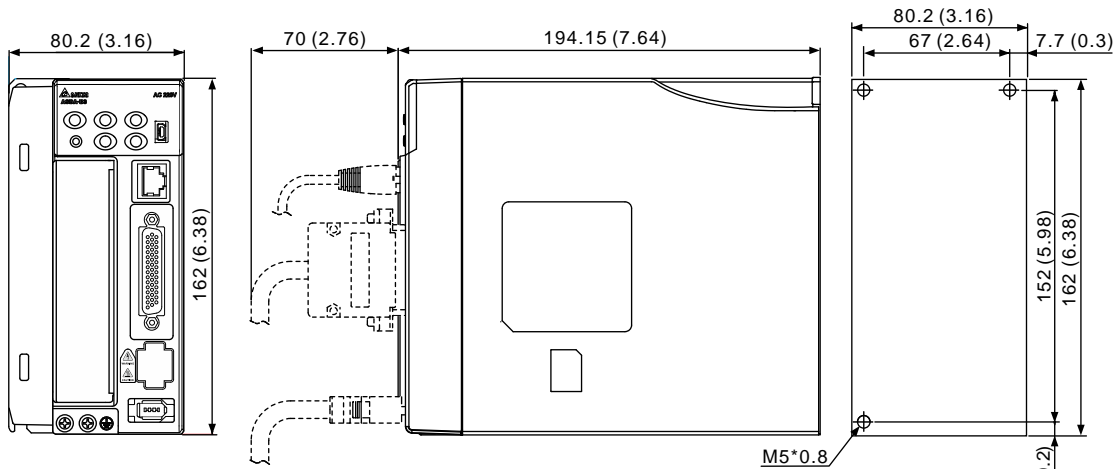

⊕ SCREW: M4 x 0.7
TIGHTENING TORQUE: 12 to 14 (kgf-cm)

Unit: mm (inch)

Weight	1.8 kg (3.96 lb)
--------	------------------

2 kW / 3 kW

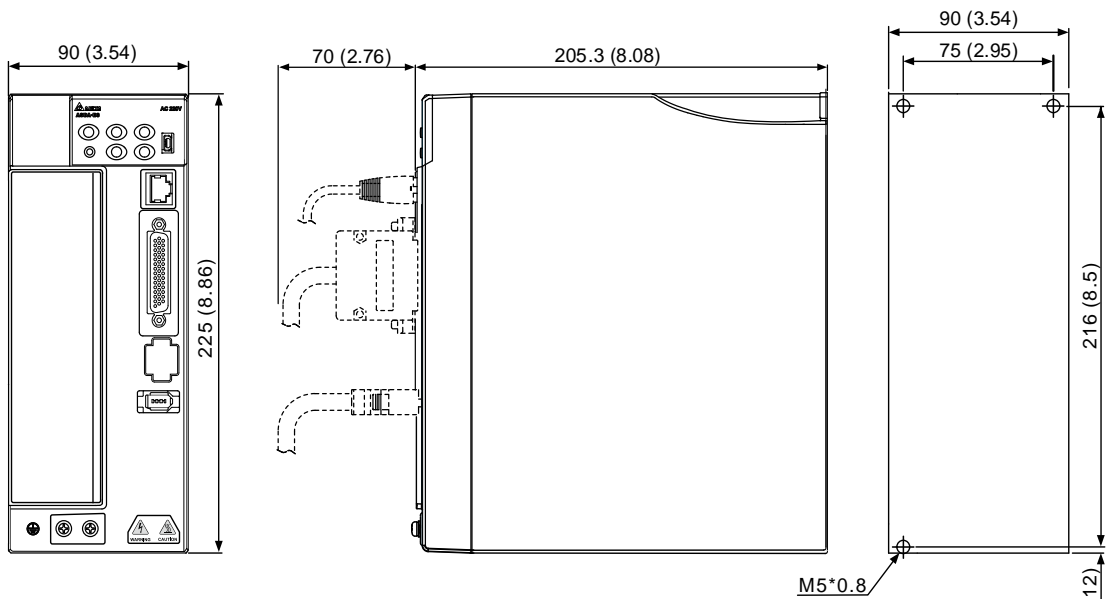

⊕ SCREW: M4 x 0.7
TIGHTENING TORQUE: 12 to 14 (kgf-cm)

Unit: mm (inch)

Weight	2.8 kg (6.17 lb)
--------	------------------

Note: dimensions and weights of the servo drive may be updated without prior notice.

A.1.2.2 400V series

1 kW / 1.5 kW / 2 kW / 3 kW

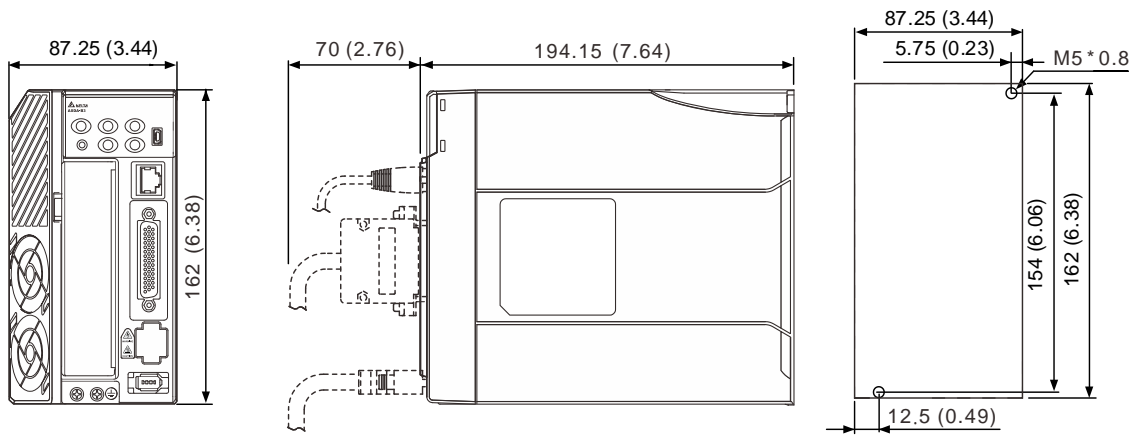

⊕ SCREW: M4 x 0.7
TIGHTENING TORQUE: 12 to 14 (kgf-cm)

Unit: mm (inch)

Weight	1.6 kg (3.53 lb)	1 kW / 1.5 kW
	1.7 kg (3.75 lb)	2 kW / 3 kW

4.5 kW / 5.5 kW / 7.5 kW

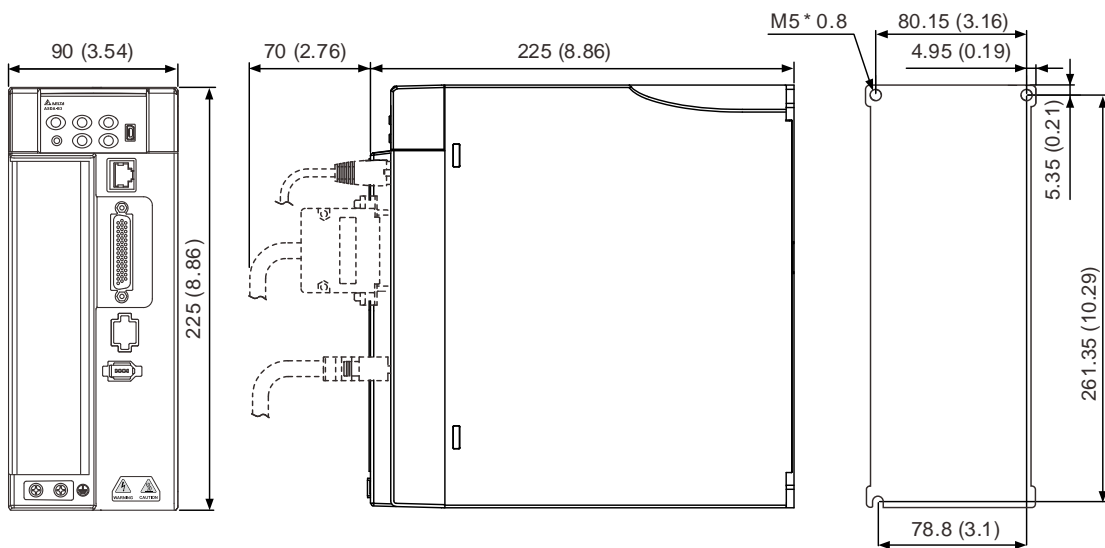

⊕ SCREW: M4 x 0.7
TIGHTENING TORQUE: 12 to 14 (kgf-cm)

Unit: mm (inch)

Weight	2.9 kg (6.39 lb)
--------	------------------

Note: dimensions and weights of the servo drive may be updated without prior notice.

A

A.2 ECM-B3 series servo motor

ECM-B3 series servo motor

A

$$\frac{\text{ECM}}{(1)} - \frac{\text{B}}{(2)} \frac{\text{3}}{(3)} \frac{\text{M}}{(4)} - \frac{\text{C}}{(5)} \frac{\text{2}}{(6)} \frac{\text{06}}{(7)} \frac{\text{04}}{(8)} \frac{\text{R}}{(9)} \frac{\text{S}}{(10)} \frac{\text{1}}{(11)}$$

(1) Product name

ECM: electronically commutated motor

(2) Servo type

B: general type servo motor

(3) Series

3: 3rd series

(4) Inertia

H: high inertia

M: medium inertia

L: low inertia

(5) Rated voltage and speed

C: 220V and 3,000 rpm

E: 220V and 2,000 rpm

F: 220V and 1,500 rpm

J: 400V and 3,000 rpm

K: 400V and 2,000 rpm

L: 400V and 1,500 rpm

(6) Encoder type

A: 24-bit absolute optical encoder

(resolution of single turn: 24-bit; number of revolutions: 16-bit)

2: 24-bit incremental optical encoder (single-turn absolute)

P: 17-bit absolute magnetic encoder

(resolution of single turn: 17-bit; number of revolutions: 16-bit)

M: 17-bit incremental magnetic encoder (single-turn absolute)

Note: number of revolutions means the maximum number of turns the encoder can record.

(7) Motor frame size

Code	Specification	Code	Specification
04	40 mm	10	100 mm
06	60 mm	13	130 mm
08	80 mm	18	180 mm

A

(8) Rated power output

Code	Specification	Code	Specification
01	100 W	15	1.5 kW
02	200 W	18	1.8 kW
04	400 W	20	2.0 kW
07	750 W	30	3.0 kW
08	850 W	45	4.5 kW
10	1.0 kW	55	5.5 kW
13	1.3 kW	75	7.5 kW

(9) Shaft type and oil seal

	w/o brake, with oil seal	with brake, with oil seal
Keyway (with fixed screw holes)	R	S

(10) Shaft diameter and connector type

S: standard shaft diameter and standard connectors

7: special shaft diameter (14 mm)^{*1} and standard connectors

J: standard shaft diameter and CHOGORI (IP67) connectors

K: special shaft diameter (14 mm)^{*1} and CHOGORI (IP67) connectors

3: standard shaft diameter (42 mm)^{*2} and standard connectors

B: standard shaft diameter and bulkhead connectors

Note:

1. Special shaft diameter (14 mm) is only available for F80 400 W models.

2. Standard shaft diameter (42 mm) is only available for F180 5.5 kW and 7.5 kW models.

(11) Special code

1: standard products

Note: the model codes listed here are only for demonstration of the naming convention; some combinations of the model codes are not available. Contact the distributors for the model numbers available for purchase.

A.2.1 ECM-B3 series servo motor

A.2.1.1 220V series

Motor frame size: 80 mm and below (low & medium inertia)

ECM-		B3L-C□0401	B3M-C□0602	B3M-C□0604	B3M-C□0804	B3M-C□0807	B3M-C□0810
Rated power (kW)		0.1	0.2	0.4	0.4	0.75	1.0
Rated torque (N·m) ¹		0.32	0.64	1.27	1.27	2.4	3.18
Max. torque (N·m)		1.12	2.24	4.45	4.45	8.4	11.13
Rated speed (rpm)		3000					
Max. speed (rpm)		6000					
Rated current (Arms)		0.857	1.42	2.40	2.53	4.27	5.00
Max. instantaneous current (Arms)		3.44	6.62	9.47	9.42	15.8	18.2
Change of rated power (kW/s)	w/o brake	34.25	29.05	63.50	24.89	53.83	73.8
	with brake	32.51	27.13	61.09	23.21	50.97	72.2
Rotor inertia (× 10 ⁻⁴ kg·m ²)	w/o brake	0.0299	0.141	0.254	0.648	1.07	1.37
	with brake	0.0315	0.151	0.264	0.695	1.13	1.40
Mechanical time constant (ms)	w/o brake	0.50	0.91	0.52	0.8	0.54	0.48
	with brake	0.53	0.97	0.54	0.86	0.57	0.49
Torque constant-KT (N·m/Arms)		0.374	0.45	0.53	0.5	0.56	0.64
Voltage constant-KE (mVrms/rpm)		13.8	16.96	19.76	18.97	20.17	23.15
Armature resistance (Ohm)		8.22	4.71	2.04	1.125	0.55	0.495
Armature inductance (mH)		19.1	12.18	6.50	5.14	2.81	2.63
Electrical time constant (ms)		2.32	2.59	3.19	4.57	5.11	5.31
Weight (kg)	w/o brake	0.5	0.9	1.2	1.7	2.34	2.82
	with brake	0.7	1.3	1.6	2.51	3.15	3.60
Max. radial load (N)		78	245	245	392	392	392
Max. axial load (N)		54	74	74	147	147	147
Brake operating voltage		24 V _{DC} ± 10%					
Brake power consumption (W) (at 20°C (68°F))		6.1	7.6	7.6	8	8	3.8
Brake holding torque [N·m (Min)] ²		0.3	1.3	1.3	2.5	2.5	10
Brake release time [ms (Max)]		20	20	20	20	20	40
Brake pull-in time [ms (Max)]		35	50	50	60	60	80
Derating rate with oil seal (%)		10	10	5	5	5	5
Insulation class		Class A (UL), Class B (CE)					
Insulation resistance		100 MΩ min. (at 500 V _{DC})					
Insulation strength		1.8 kV _{AC} , 1 sec					
Vibration grade		V15					
Ambient temperature		-20°C to +60°C (-4°F to +140°F) ³					
Storage temperature		-20°C to +80°C (-4°F to +176°F)					
Ambient and storage humidity		20 - 90% RH (non-condensing)					
Vibration capacity		2.5 G					

ECM-	B3L- C□0401	B3M- C□0602	B3M- C□0604	B3M- C□0804	B3M- C□0807	B3M- C□0810
IP rating	IP67 (for models using waterproof connectors and shaft seals or oil seals)					
Approvals						

A

Note:

1. The rated torque is the continuous permissible torque between 0°C - 40°C (32°F - 104°F) ambient temperature which is suitable for the servo motor mounted with the heat sink of the following dimensions.
 F40, F60, and F80: 250 mm x 250 mm x 6 mm
 Material: aluminum
2. The built-in servo motor brake is only for keeping the object installed on the motor in a stopped state. Do not use it for deceleration or as a dynamic brake.
3. If the ambient temperature is over 40°C (104°F), refer to Section A.2.3 Power derating curves of the B3 motor.
4. Follow the load specification for the motor shaft during operation. The load for the motor shaft is defined as follows.

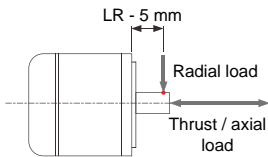

A

Motor frame size: 80 mm and below (high inertia)

ECM-		B3H-C□0602	B3H-C□0604	B3H-C□0807
Rated power (kW)		0.2	0.4	0.75
Rated torque (N·m) ^{*1}		0.64	1.27	2.4
Max. torque (N·m)		2.43	4.83	9.12
Rated speed (rpm)		3000	3000	3000
Max. speed (rpm)		6700	6700	6700
Rated current (Arms)		1.51	2.21	4.19
Max. instantaneous current (Arms)		6.12	8.46	16.3
Change of rated power (kW/s)	w/o brake	15.5	30.8	37.2
	with brake	14.6	30.0	35.6
Rotor inertia (× 10 ⁻⁴ kg·m ²)	w/o brake	0.265	0.523	1.55
	with brake	0.280	0.538	1.62
Mechanical time constant (ms)	w/o brake	1.78	1.31	0.825
	with brake	1.88	1.34	0.862
Torque constant-KT (N·m/Arms)		0.424	0.575	0.573
Voltage constant-KE (mVrms/rpm)		15.3	20.8	20.2
Armature resistance (Ohm)		4.17	2.85	0.588
Armature inductance (mH)		2	3.5	1
Electrical time constant (ms)		0.48	1.23	1.70
Weight (kg)	w/o brake	0.70	1.05	2.15
	with brake	1.23	1.6	2.95
Max. radial load (N)		245	245	392
Max. axial load (N)		74	74	147
Brake operating voltage		24 V _{DC} ± 10%		
Brake power consumption (W) (at 20°C (68°F))		7.6	7.6	8
Brake holding torque [N·m (Min)] ^{*2}		1.3	1.3	2.5
Brake release time [ms (Max)]		20	20	20
Brake pull-in time [ms (Max)]		50	50	60
Derating rate with oil seal (%)		10	5	5
Insulation class		Class A (UL), Class B (CE)		
Insulation resistance		100 MΩ min. (at 500 V _{DC})		
Insulation strength		1.8 kV _{AC} , 1 sec		
Vibration grade		V15		
Ambient temperature		-20°C to +60°C (-4°F to +140°F) ^{*3}		
Storage temperature		-20°C to +80°C (-4°F to +176°F)		
Ambient and storage humidity		20 - 90% RH (non-condensing)		
Vibration capacity		2.5 G		
IP rating		IP67 (for models using shaft seals or oil seals)		
Approvals				

Note:

1. The rated torque is the continuous permissible torque between 0°C - 40°C (32°F - 104°F) ambient temperature which is suitable for the servo motor mounted with the heat sink of the following dimensions.
F40, F60, and F80: 250 mm x 250 mm x 6 mm
Material: aluminum
2. The built-in servo motor brake is only for keeping the object installed on the motor in a stopped state. Do not use it for deceleration or as a dynamic brake.
3. If the ambient temperature is over 40°C (104°F), refer to Section A.2.3 Power derating curves of the B3 motor.
4. Follow the load specification for the motor shaft during operation. The load for the motor shaft is defined as follows.

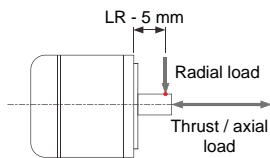

A

A

Motor frame size: 100 mm (medium inertia)

ECM-		B3M-C□1010	B3M-C□1015	B3M-C□1020
Rated power (kW)		1	1.5	2
Rated torque (N·m) ¹		3.18	4.77	6.37
Max. torque (N·m)		9.54	14.31	19.11
Rated speed (rpm)		3000		
Max. speed (rpm)		6000		
Rated current (Arms)		6.05	7.48	9.96
Max. instantaneous current (Arms)		18.4	22.8	30.7
Change of rated power (kW/s)	w/o brake	36.4	61.7	86.7
	with brake	33.0	57.3	82.0
Rotor inertia (× 10 ⁻⁴ kg·m ²)	w/o brake	2.78	3.69	4.68
	with brake	3.06	3.97	4.95
Mechanical time constant (ms)	w/o brake	0.741	0.552	0.523
	with brake	0.815	0.594	0.554
Torque constant-KT (N·m/Arms)		0.526	0.638	0.640
Voltage constant-KE (mVrms/rpm)		19.8	23.8	23.7
Armature resistance (Ohm)		0.265	0.217	0.162
Armature inductance (mH)		1.86	1.71	1.23
Electrical time constant (ms)		7.02	7.88	7.59
Weight (kg)	w/o brake	3.56	4.37	5.09
	with brake	4.88	5.68	6.51
Max. radial load (N)		490	490	490
Max. axial load (N)		196	196	196
Brake operating voltage		24 V _{DC} ± 10%		
Brake power consumption (W) (at 20°C (68°F))		17.6	17.6	17.6
Brake holding torque [N·m (Min)] ²		9.5	9.5	9.5
Brake release time [ms (Max)]		50	50	50
Brake pull-in time [ms (Max)]		110	110	110
Derating rate with oil seal (%)		5	5	5
Insulation class		Class A (UL), Class B (CE)		
Insulation resistance		100 MΩ min. (at 500 V _{DC})		
Insulation strength		1.8 kV _{AC} , 1 sec		
Vibration grade		V15		
Ambient temperature		-20°C to +60°C (-4°F to +140°F) ³		
Storage temperature		-20°C to +80°C (-4°F to +176°F)		
Ambient and storage humidity		20 - 90% RH (non-condensing)		
Vibration capacity		2.5 G		
IP rating		IP67 (for models using shaft seals or oil seals)		
Approvals				

Note:

1. The rated torque is the continuous permissible torque between 0°C and 40°C (32°F and 104°F) ambient temperature which is suitable for the servo motor mounted with the heat sink of the following dimensions.

F100: 300 mm x 300 mm x 12 mm

Material: aluminum

2. The built-in servo motor brake is only for keeping the object in a stopped state. Do not use it for deceleration or as a dynamic brake.
3. If the ambient temperature is over 40°C (104°F), refer to Section A.2.3 Power derating curves of the B3 motors.
4. Follow the load specification for the motor shaft during operation. The load for the motor shaft is defined as follows.

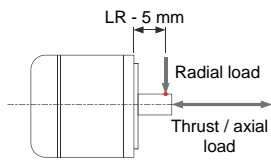

A

A

Motor frame size: 130 mm (medium & high inertia)

ECM-	B3M- E□1310	B3M- E□1315	B3M- E□1320	B3H- F□1308	B3H- F□1313	B3H- F□1318	
Rated power (kW)	1	1.5	2	0.85	1.3	1.8	
Rated torque (N·m) ^{*1}	4.77	7.16	9.55	5.39	8.34	11.5	
Max. torque (N·m)	14.3	21.48	28.65	16.17	25.02	34.5	
Rated speed (rpm)	2000			1500			
Max. speed (rpm)	3000			4000			
Rated current (Arms)	5.96	8.17	10.59	6.65	7.70	11.5	
Max. instantaneous current (Arms)	19.9	26.82	34.20	20.0	23.9	36.1	
Change of rated power (kW/s)	w/o brake	29.21	45.69	62.25	23.4	38.6	58.5
	with brake	28.66	45.09	61.62	23.0	38.3	58.0
Rotor inertia (× 10 ⁻⁴ kg·m ²)	w/o brake	7.79	11.22	14.65	12.44	18.00	22.60
	with brake	7.94	11.37	14.8	12.62	18.14	22.80
Mechanical time constant (ms)	w/o brake	1.46	1.10	1.03	2.48	1.98	1.70
	with brake	1.49	1.12	1.04	2.52	1.99	1.71
Torque constant-KT (N·m/Arms)	0.80	0.88	0.90	0.811	1.08	1.00	
Voltage constant-KE (mVrms/rpm)	29.30	31.69	32.70	29.8	38.8	35.3	
Armature resistance (Ohm)	0.419	0.260	0.198	0.460	0.440	0.253	
Armature inductance (mH)	4	2.81	2.18	2.50	2.76	1.70	
Electrical time constant (ms)	9.55	10.81	11.01	5.43	6.27	6.72	
Weight (kg)	w/o brake	4.9	6.0	7.0	6.0	7.0	8.0
	with brake	6.3	7.4	8.5	7.5	8.5	9.5
Max. radial load (N)	490	686	980	490	686	980	
Max. axial load (N)	98	343	392	98	343	392	
Brake operating voltage	24 V _{DC} ± 10%						
Brake power consumption (W) (at 20°C (68°F))	21.5	21.5	21.5	24	24	24	
Brake holding torque [N·m (Min)] ^{*2}	10	10	10	16	16	16	
Brake release time [ms (Max)]	50	50	50	60	60	60	
Brake pull-in time [ms (Max)]	110	110	110	120	120	120	
Derating rate with oil seal (%)	5	5	5	5	5	5	
Insulation class	Class A (UL), Class B (CE)			Class F (UL), Class F (CE)			
Insulation resistance	100 MΩ min. (at 500 V _{DC})						
Insulation strength	1.8 kV _{AC} , 1 sec						
Vibration grade	V15						
Ambient temperature	-20°C to +60°C (-4°F to +140°F) ^{*3}						
Storage temperature	-20°C to +80°C (-4°F to +176°F)						
Ambient and storage humidity	20 - 90% RH (non-condensing)						
Vibration capacity	2.5 G						
IP rating	IP67 (for models using shaft seals or oil seals)						
Approvals							

Note:

1. The rated torque is the continuous permissible torque between 0°C - 40°C (32°F - 104°F) ambient temperature which is suitable for the servo motor mounted with the heat sink of the following dimensions.
F130: 400 mm x 400 mm x 20 mm
Material: aluminum
2. The built-in servo motor brake is only for keeping the object in a stopped state. Do not use it for deceleration or as a dynamic brake.
3. If the ambient temperature is over 40°C (104°F), refer to Section A.2.3 Power derating curves of the B3 motor.
4. Follow the load specification for the motor shaft during operation. The load for the motor shaft is defined as follows.

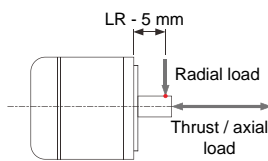

A

A

Motor frame size: 180 mm (medium inertia)

ECM-		B3M-E□1820	B3M-F□1830
Rated power (kW)		2	3
Rated torque (N·m) ¹		9.55	19.1
Max. torque (N·m)		28.65	57.29
Rated speed (rpm)		2000	1500
Max. speed (rpm)		3000	3000
Rated current (Arms)		11.43	18.21
Max. instantaneous current (Arms)		36.21	58.9
Change of rated power (kW/s)	w/o brake	31.33	68.02
	with brake	30.02	66.45
Rotor inertia (× 10 ⁻⁴ kg·m ²)	w/o brake	29.11	53.63
	with brake	30.38	54.9
Mechanical time constant (ms)	w/o brake	1.83	1.21
	with brake	1.91	1.24
Torque constant-KT (N·m/Arms)		0.836	1.05
Voltage constant-KE (mVrms/rpm)		31.6	37.9
Armature resistance (Ohm)		0.159	0.086
Armature inductance (mH)		2.34	1.52
Electrical time constant (ms)		14.72	17.67
Weight (kg)	w/o brake	10	13.9
	with brake	13.7	17.6
Max. radial load (N)		1470	1470
Max. axial load (N)		490	490
Brake operating voltage		24 V _{DC} ± 10%	
Brake power consumption (W) (at 20°C (68°F))		31	31
Brake holding torque [N·m (Min)] ²		25	25
Brake release time [ms (Max)]		30	30
Brake pull-in time [ms (Max)]		120	120
Derating rate with oil seal (%)		5	5
Insulation class		Class A (UL), Class B (CE)	
Insulation resistance		100 MΩ min. (at 500 V _{DC})	
Insulation strength		1.8 kV _{AC} , 1 sec	
Vibration grade		V15	
Ambient temperature		-20°C to +60°C (-4°F to +140°F) ³	
Storage temperature		-20°C to +80°C (-4°F to +176°F)	
Ambient and storage humidity		20 - 90% RH (non-condensing)	
Vibration capacity		2.5 G	
IP rating		IP67 (for models using shaft seals or oil seals)	
Approvals			

Note:

1. The rated torque is the continuous permissible torque between 0°C and 40°C (32°F and 104°F) ambient temperature which is suitable for the servo motor mounted with the heat sink of the following dimensions.

F180: 550 mm x 550 mm x 30 mm

Material: aluminum

2. The built-in servo motor brake is only for keeping the object in a stopped state. Do not use it for deceleration or as a dynamic brake.
3. If the ambient temperature is over 40°C (104°F), refer to Section A.2.3 Power derating curves of the B3 motors.
4. Follow the load specification for the motor shaft during operation. The load for the motor shaft is defined as follows.

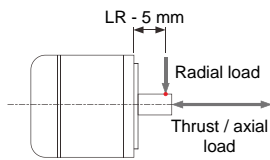

A

A.2.1.2 400V series

Motor frame size: 80 mm and below (medium inertia)

ECM-	B3M-J□0807	
Rated power (kW)	0.75	
Rated torque (N·m) ^{*1}	2.4	
Max. torque (N·m)	8.4	
Rated speed (rpm)	3000	
Max. speed (rpm)	6000	
Rated current (Arms)	2.15	
Max. instantaneous current (Arms)	7.90	
Change of rated power (kW/s)	w/o brake	53.83
	with brake	50.97
Rotor inertia (× 10 ⁻⁴ kg·m ²)	w/o brake	1.07
	with brake	1.13
Mechanical time constant (ms)	w/o brake	0.55
	with brake	0.58
Torque constant-KT (N·m/Arms)	1.12	
Voltage constant-KE (mVrms/rpm)	40.34	
Armature resistance (Ohm)	2.20	
Armature inductance (mH)	11.2	
Electrical time constant (ms)	5.09	
Weight (kg)	w/o brake	2.34
	with brake	3.15
Max. radial load (N)	392	
Max. axial load (N)	147	
Brake operating voltage	24 V _{DC} ± 10%	
Brake power consumption (W) (at 20°C (68°F))	8	
Brake holding torque [N·m (Min)] ²	2.5	
Brake release time [ms (Max)]	20	
Brake pull-in time [ms (Max)]	60	
Derating rate with oil seal (%)	5	
Insulation class	Class A (UL), Class B (CE)	
Insulation resistance	100 MΩ min. (at 500 V _{DC})	
Insulation strength	2.3 kV _{AC} , 1 sec	
Vibration grade	V15	
Ambient temperature	-20°C to +60°C (-4°F to +140°F) ³	
Storage temperature	-20°C to +80°C (-4°F to +176°F)	
Ambient and storage humidity	20 - 90% RH (non-condensing)	
Vibration capacity	2.5 G	
IP rating	IP67 (for models using waterproof connectors and shaft seals or oil seals)	
Approvals		

Note:

1. The rated torque is the continuous permissible torque between 0°C and 40°C (32°F and 104°F) ambient temperature which is suitable for the servo motor mounted with the heat sink of the following dimensions.

F60 and F80: 250 mm x 250 mm x 6 mm

Material: aluminum

2. The built-in servo motor brake is only for keeping the object in a stopped state. Do not use it for deceleration or as a dynamic brake.
3. If the ambient temperature is over 40°C (104°F), refer to Section A.2.3 Power derating curves of the B3 motors.
4. Follow the load specification for the motor shaft during operation. The load for the motor shaft is defined as follows.

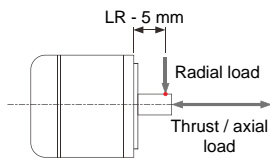

A

Motor frame size: 100 mm (medium inertia)

ECM-		B3M-J□1010	B3M-J□1015	B3M-J□1020
Rated power (kW)		1	1.5	2
Rated torque (N·m) ¹		3.18	4.77	6.37
Max. torque (N·m)		9.54	14.31	19.11
Rated speed (rpm)		3000		
Max. speed (rpm)		6000		
Rated current (Arms)		3.03	3.73	5.00
Max. instantaneous current (Arms)		9.21	11.4	15.3
Change of rated power (kW/s)	w/o brake	36.4	61.7	86.7
	with brake	33.0	57.3	82.0
Rotor inertia (× 10 ⁻⁴ kg·m ²)	w/o brake	2.78	3.69	4.68
	with brake	3.06	3.97	4.95
Mechanical time constant (ms)	w/o brake	0.737	0.546	0.528
	with brake	0.811	0.587	0.559
Torque constant-KT (N·m/Arms)		1.05	1.28	1.27
Voltage constant-KE (mVrms/rpm)		39.5	47.8	47.2
Armature resistance (Ohm)		1.05	0.864	0.646
Armature inductance (mH)		7.50	6.63	4.89
Electrical time constant (ms)		7.14	7.67	7.57
Weight (kg)	w/o brake	3.56	4.37	5.09
	with brake	4.88	5.68	6.505
Max. radial load (N)		490	490	490
Max. axial load (N)		196	196	196
Brake operating voltage		24 V _{DC} ± 10%		
Brake power consumption (W) (at 20°C (68°F))		17.6	17.6	17.6
Brake holding torque [N·m (Min)] ²		9.5	9.5	9.5
Brake release time [ms (Max)]		50	50	50
Brake pull-in time [ms (Max)]		110	110	110
Derating rate with oil seal (%)		5	5	5
Insulation class		Class A (UL), Class B (CE)		
Insulation resistance		100 MΩ min. (at 500 V _{DC})		
Insulation strength		2.3 kV _{AC} , 1 sec		
Vibration grade		V15		
Ambient temperature		-20°C to +60°C (-4°F to +140°F) ³		
Storage temperature		-20°C to +80°C (-4°F to +176°F)		
Ambient and storage humidity		20 - 90% RH (non-condensing)		
Vibration capacity		2.5 G		
IP rating		IP67 (for models using shaft seals or oil seals)		
Approvals				

A

Note:

1. The rated torque is the continuous permissible torque between 0°C and 40°C (32°F and 104°F) ambient temperature which is suitable for the servo motor mounted with the heat sink of the following dimensions.

F100: 300 mm x 300 mm x 12 mm

Material: aluminum

2. The built-in servo motor brake is only for keeping the object in a stopped state. Do not use it for deceleration or as a dynamic brake.
3. If the ambient temperature is over 40°C (104°F), refer to Section A.2.3 Power derating curves of the B3 motors.
4. Follow the load specification for the motor shaft during operation. The load for the motor shaft is defined as follows.

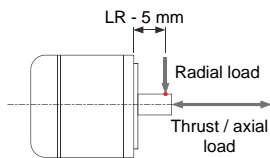

A

A

Motor frame size: 130 mm (medium & high inertia)

ECM-		B3M- K□1310	B3M- K□1315	B3M- K□1320	B3H- L□1308	B3H- L□1313	B3H- L□1318
Rated power (kW)		1.0	1.5	2.0	0.85	1.3	1.8
Rated torque (N·m) ^{*1}		4.77	7.16	9.55	5.39	8.34	11.5
Max. torque (N·m)		14.3	21.48	28.65	16.17	25.02	34.5
Rated speed (rpm)		2000			1500		
Max. speed (rpm)		3000			4000		
Rated current (Arms)		3.00	4.09	5.30	3.35	3.85	5.75
Max. instantaneous current (Arms)		9.95	13.37	17.1	10.0	12.0	18.1
Change of rated power (kW/s)	w/o brake	29.21	45.69	62.25	23.4	38.6	58.5
	with brake	28.66	45.09	61.62	23.0	38.3	58.0
Rotor inertia (× 10 ⁻⁴ kg·m ²)	w/o brake	7.79	11.22	14.65	12.44	18.00	22.60
	with brake	7.94	11.37	14.80	12.62	18.14	22.80
Mechanical time constant (ms)	w/o brake	1.47	1.10	1.03	2.50	1.97	1.69
	with brake	1.50	1.12	1.04	2.54	1.99	1.71
Torque constant-KT (N·m/Arms)		1.59	1.75	1.80	1.61	2.17	2.00
Voltage constant-KE (mVrms/rpm)		58.60	63.38	65.40	59.5	77.6	70.7
Armature resistance (Ohm)		1.68	1.04	0.792	1.84	1.76	1.01
Armature inductance (mH)		16.0	11.2	8.72	10.0	11.0	6.80
Electrical time constant (ms)		9.52	10.8	11.0	5.43	6.25	6.73
Weight (kg)	w/o brake	4.9	6.0	7.0	6.0	7.0	8.0
	with brake	6.3	7.4	8.5	7.5	8.5	9.5
Max. radial load (N)		490	686	980	490	686	980
Max. axial load (N)		98	343	392	98	343	392
Brake operating voltage		24 V _{DC} ± 10%					
Brake power consumption (W) (at 20°C (68°F))		21.5	21.5	21.5	24	24	24
Brake holding torque [N·m (Min)] ^{*2}		10	10	10	16	16	16
Brake release time [ms (Max)]		50	50	50	60	60	60
Brake pull-in time [ms (Max)]		110	110	110	120	120	120
Derating rate with oil seal (%)		5	5	5	5	5	5
Insulation class		Class A (UL), Class B (CE)			Class F (UL), Class F (CE)		
Insulation resistance		100 MΩ min. (at 500 V _{DC})					
Insulation strength		2.3 kV _{AC} , 1 sec					
Vibration grade		V15					
Ambient temperature		-20°C to +60°C (-4°F to +140°F) ^{*3}					
Storage temperature		-20°C to +80°C (-4°F to +176°F)					
Ambient and storage humidity		20 - 90% RH (non-condensing)					
Vibration capacity		2.5 G					
IP rating		IP67 (for models using shaft seals or oil seals)					
Approvals							

Note:

1. The rated torque is the continuous permissible torque between 0°C and 40°C (32°F and 104°F) ambient temperature which is suitable for the servo motor mounted with the heat sink of the following dimensions.
F130: 400 mm x 400 mm x 20 mm
Material: aluminum
2. The built-in servo motor brake is only for keeping the object in a stopped state. Do not use it for deceleration or as a dynamic brake.
3. If the ambient temperature is over 40°C (104°F), refer to Section A.2.3 Power derating curves of the B3 motors.
4. Follow the load specification for the motor shaft during operation. The load for the motor shaft is defined as follows.

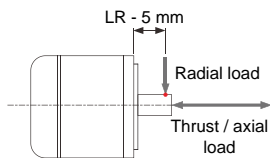

A

A

Motor frame size: 180 mm (medium inertia)

ECM-		B3M-K□1820	B3M-L□1830	B3M-L□1845	B3M-L□1855	B3M-L□1875
Rated power (kW)		2	3	4.5	5.5	7.5
Rated torque (N·m) ^{*1}		9.55	19.1	28.65	35.01	47.75
Max. torque (N·m)		28.65	57.29	71.6	105	119
Rated speed (rpm)		2000	1500	1500		
Max. speed (rpm)		3000	3000	4000		
Rated current (Arms)		5.7	9.1	13.3	15.3	22.1
Max. instantaneous current (Arms)		18.1	29.45	35.35	49.29	56.68
Change of rated power (kW/s)	w/o brake	31.33	68.02	121	124	169
	with brake	30.02	66.45	119	122	167
Rotor inertia (× 10 ⁻⁴ kg·m ²)	w/o brake	29.11	53.63	67.73	98.88	134.95
	with brake	30.38	54.9	69.15	100.1	136.24
Mechanical time constant (ms)	w/o brake	1.83	1.21	1.07	1.01	1.01
	with brake	1.91	1.24	1.09	1.02	1.02
Torque constant-KT (N·m/Arms)		1.68	2.10	2.15	2.29	2.16
Voltage constant-KE (mVrms/rpm)		63.2	75.8	78.8	81.8	77.4
Armature resistance (Ohm)		0.636	0.344	0.255	0.182	0.120
Armature inductance (mH)		9.36	6.08	4.68	3.48	2.27
Electrical time constant (ms)		14.72	17.67	18.4	19.1	18.9
Weight (kg)	w/o brake	10	13.9	16.5	21.2	27.2
	with brake	13.7	17.6	20.2	24.9	30.9
Max. radial load (N)		1470	1470	1470	1764	1764
Max. axial load (N)		490	490	490	588	588
Brake operating voltage		24 V _{DC} ± 10%				
Brake power consumption (W) (at 20°C (68°F))		31	31	31	31	31
Brake holding torque [N·m (Min)] ^{*2}		25	25	55	55	55
Brake release time [ms (Max)]		30	30	50	50	50
Brake pull-in time [ms (Max)]		120	120	150	150	150
Derating rate with oil seal (%)		5	5	0	0	0
Insulation class		Class A (UL), Class B (CE)		Class F (UL), Class F (CE)		
Insulation resistance		100 MΩ min. (at 500 V _{DC})				
Insulation strength		2.3 kV _{AC} , 1 sec				
Vibration grade		V15				
Ambient temperature		-20°C to +60°C (-4°F to +140°F) ^{*3}				
Storage temperature		-20°C to +80°C (-4°F to +176°F)				
Ambient and storage humidity		20 - 90% RH (non-condensing)				
Vibration capacity		2.5 G				
IP rating		IP67 (for models using shaft seals or oil seals)				
Approvals						

Note:

1. The rated torque is the continuous permissible torque between 0°C and 40°C (32°F and 104°F) ambient temperature which is suitable for the servo motor mounted with the heat sink of the following dimensions.
F180: 550 mm x 550 mm x 30 mm
Material: aluminum
2. The built-in servo motor brake is only for keeping the object in a stopped state. Do not use it for deceleration or as a dynamic brake.
3. If the ambient temperature is over 40°C (104°F), refer to Section A.2.3 Power derating curves of the B3 motors.
4. Follow the load specification for the motor shaft during operation. The load for the motor shaft is defined as follows.

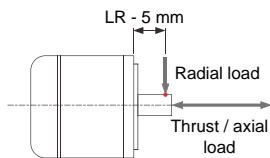

A

A.2.2 Torque features (T-N curves) of the B3 motors

A.2.2.1 220V series

Motor frame size: 80 mm and below

A

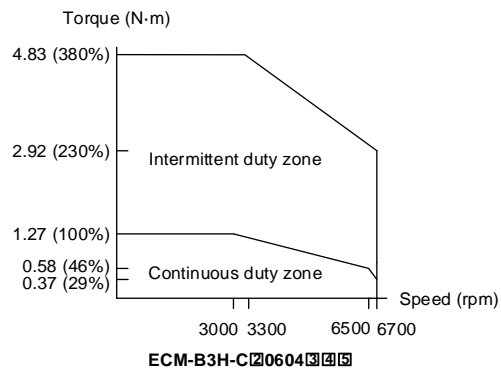
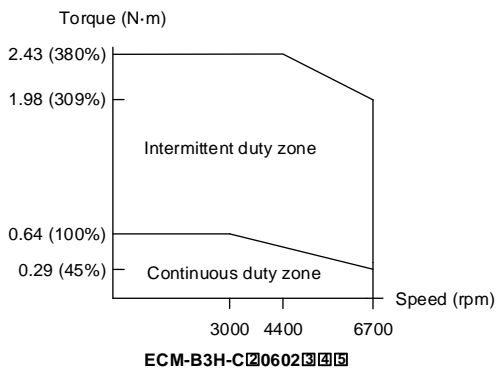
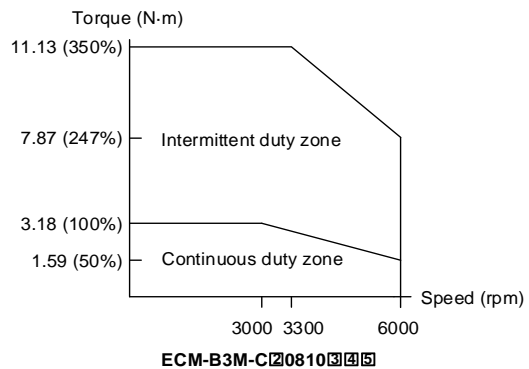
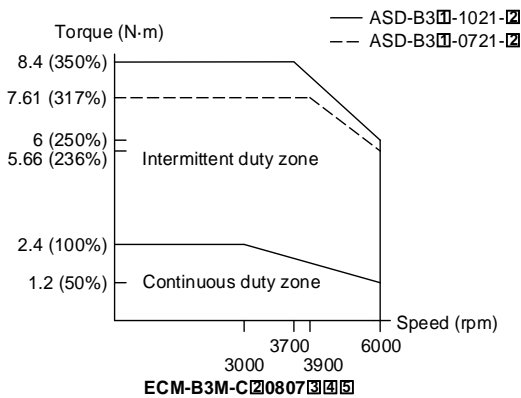
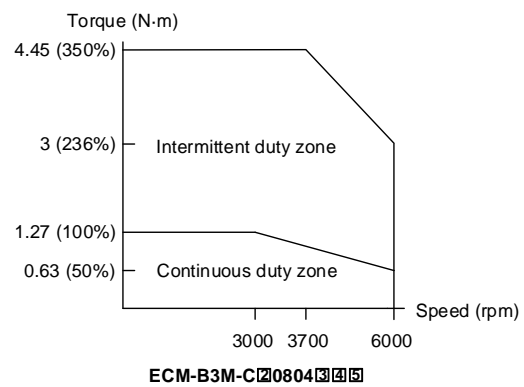
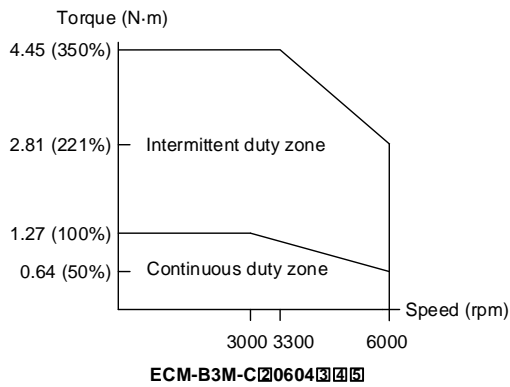
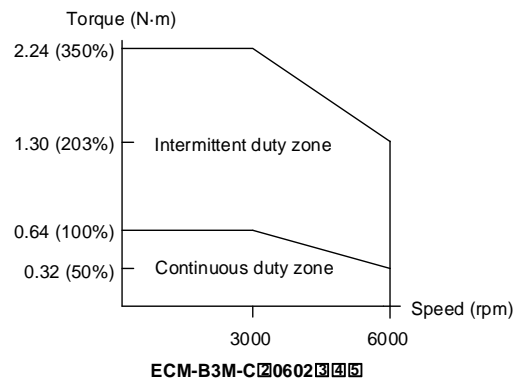
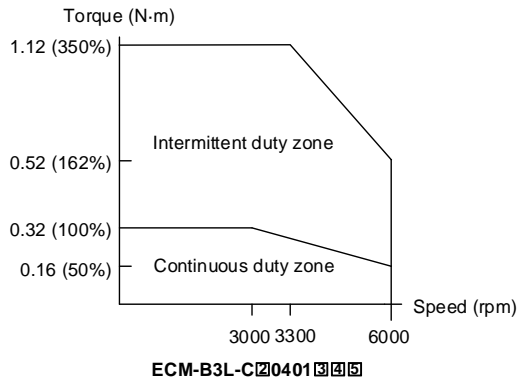

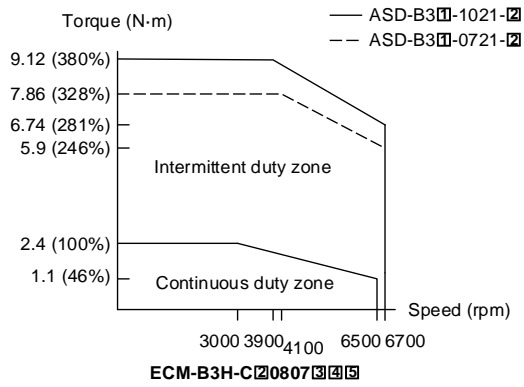

A

Note: in the servo motor model number, □ represents the encoder type; □ represents the brake or keyway / oil seal type; □ represents the shaft diameter and connector type; and □ represents the special code.

A

Motor frame size: 100 mm

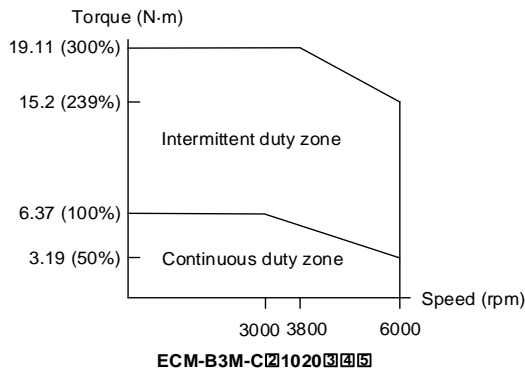
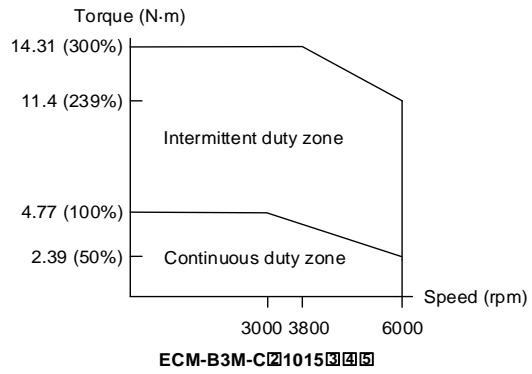
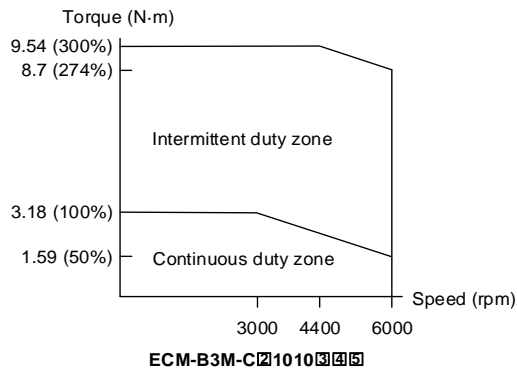

Note: in the servo motor model number, [2] represents the encoder type; [3] represents the brake or keyway / oil seal type; [4] represents the shaft diameter and connector type; and [5] represents the special code.

Motor frame size: 130 mm

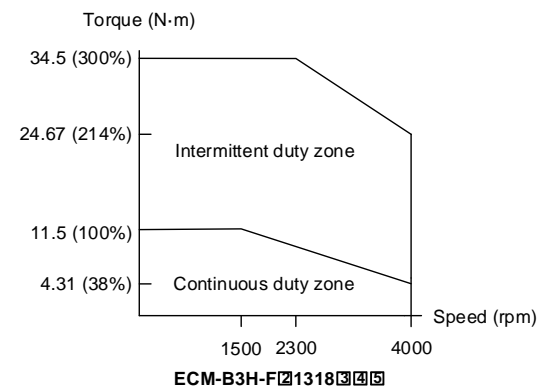
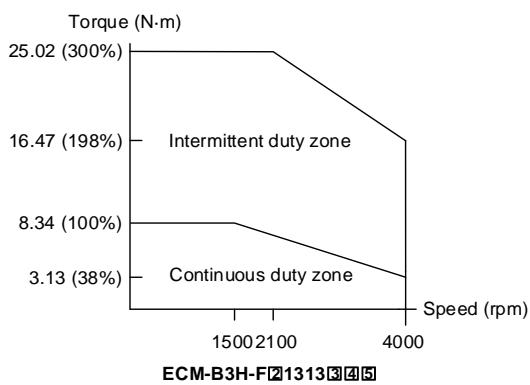
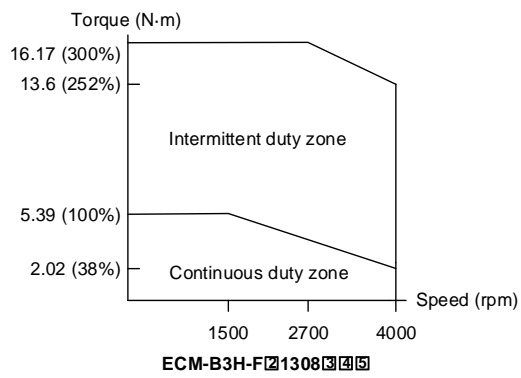
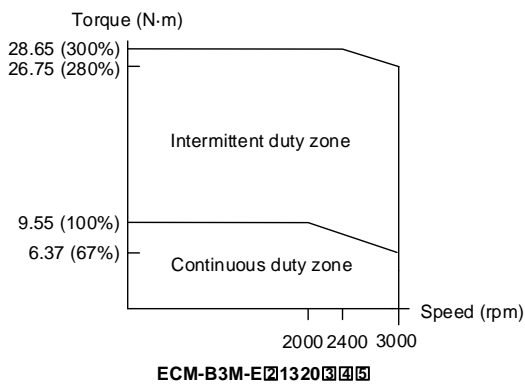
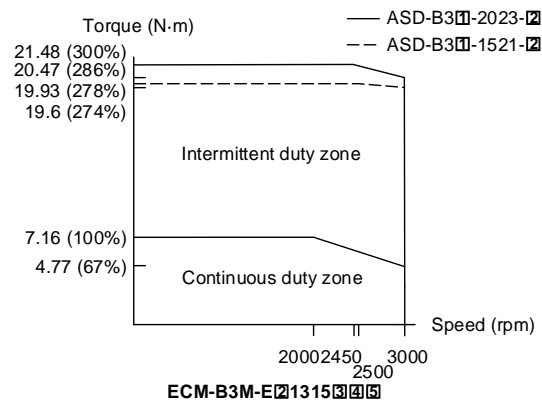
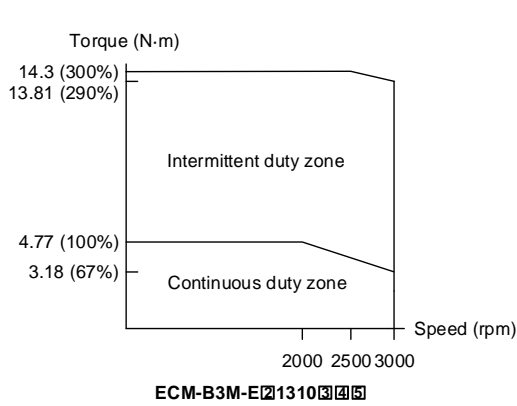

Note: in the servo motor model number, [2] represents the encoder type; [3] represents the brake or keyway / oil seal type; [4] represents the shaft diameter and connector type; and [5] represents the special code.

A

Motor frame size: 180 mm

A

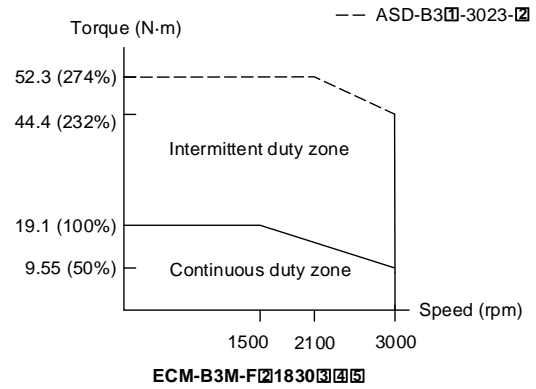
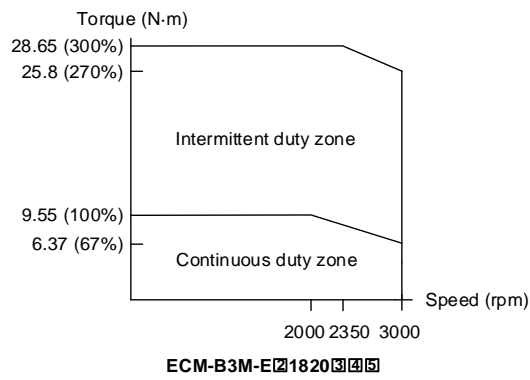

Note: in the servo motor model number, [2] represents the encoder type; [3] represents the brake or keyway / oil seal type; [4] represents the shaft diameter and connector type; and [5] represents the special code.

A.2.2.2 400V series

Motor frame size: 80 mm and below

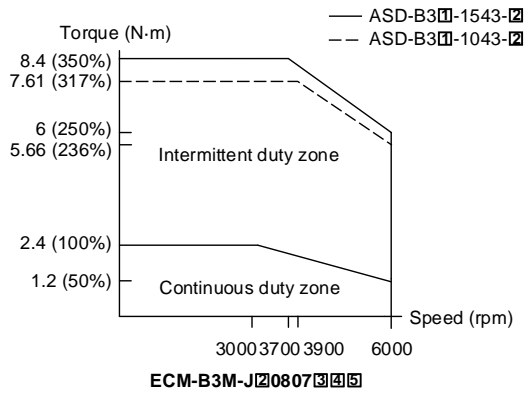

A

Motor frame size: 100 mm

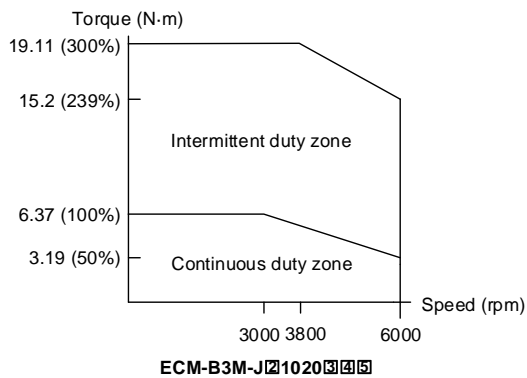
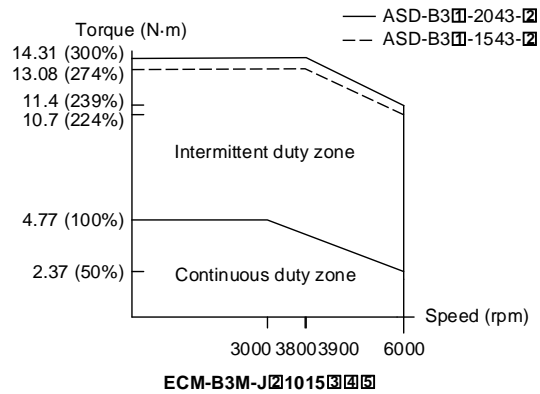
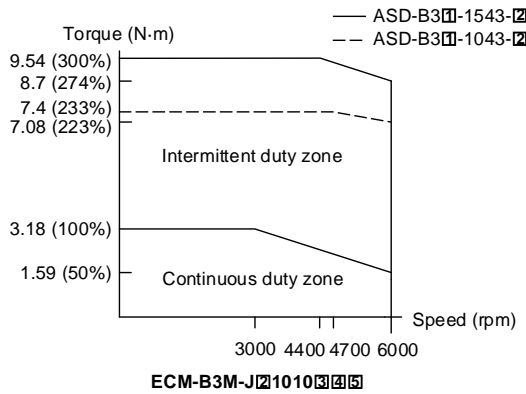

Note: in the servo motor model number, □ represents the encoder type; □ represents the brake or keyway / oil seal type; □ represents the shaft diameter and connector type; and □ represents the special code.

A

Motor frame size: 130 mm

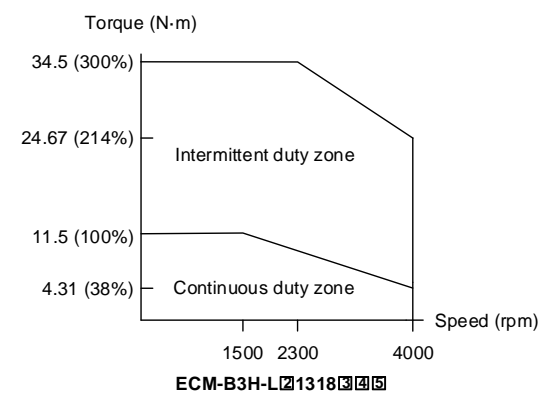
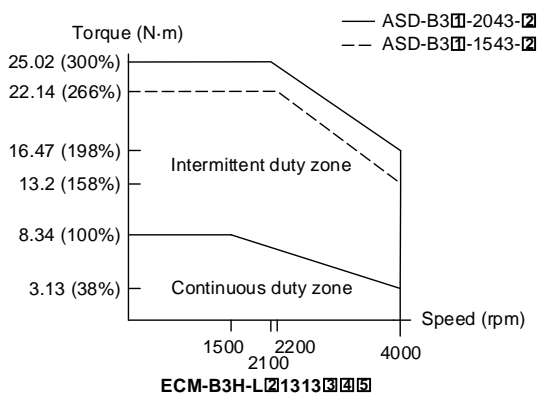
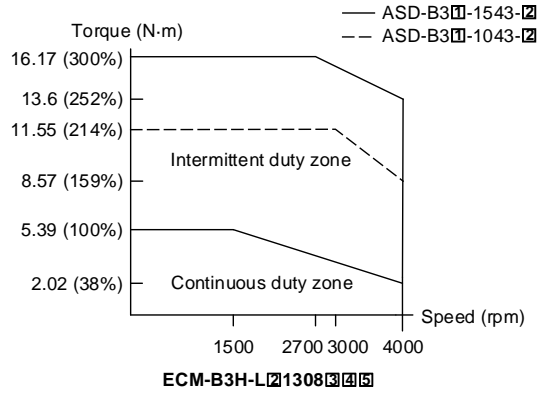
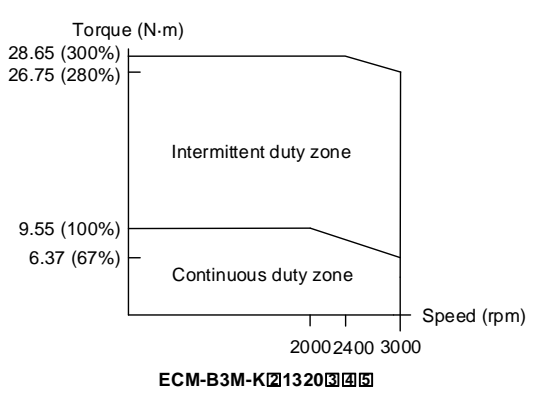
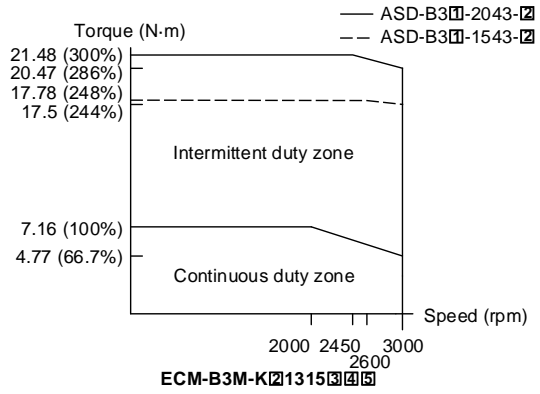
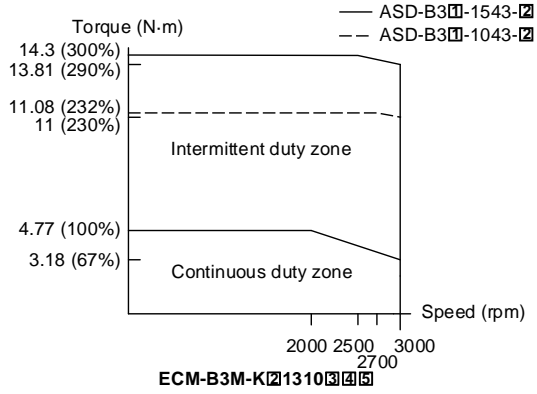

Note: in the servo motor model number, [2] represents the encoder type; [3] represents the brake or keyway / oil seal type; [4] represents the shaft diameter and connector type; and [5] represents the special code.

Motor frame size: 180 mm

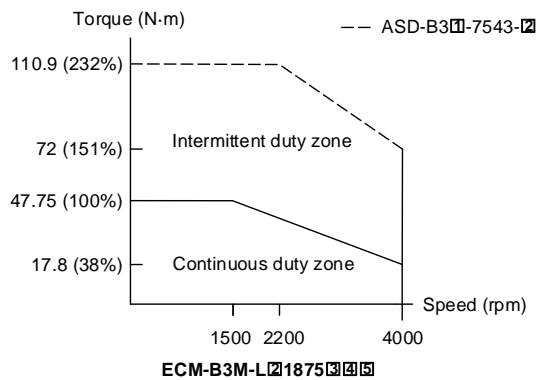
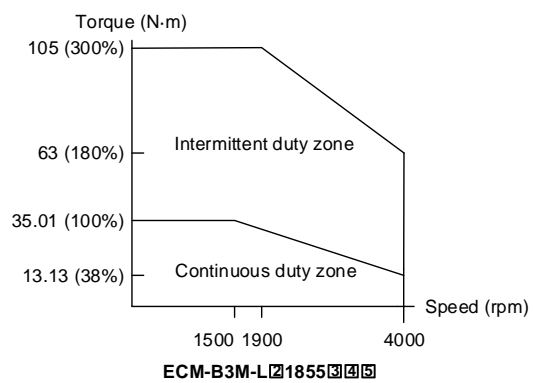
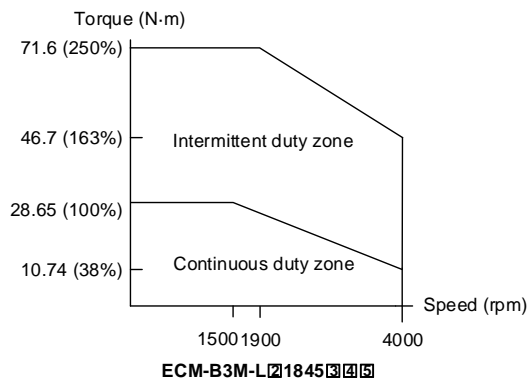
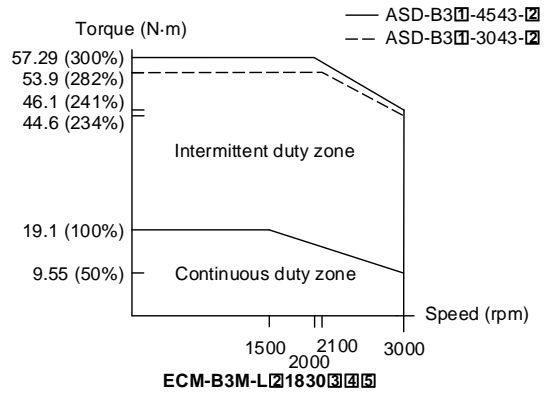
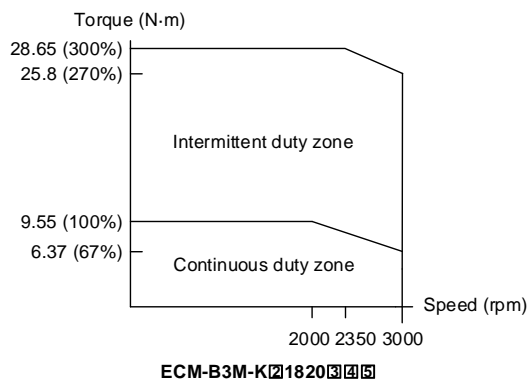

Note: in the servo motor model number, [2] represents the encoder type; [3] represents the brake or keyway / oil seal type; [4] represents the shaft diameter and connector type; and [5] represents the special code.

A

A.2.3 Power derating curves of the B3 motors

A

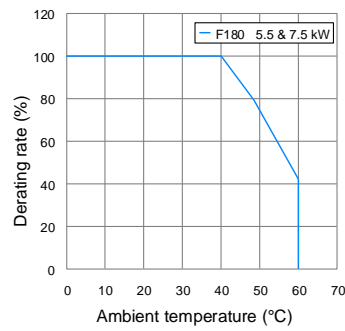
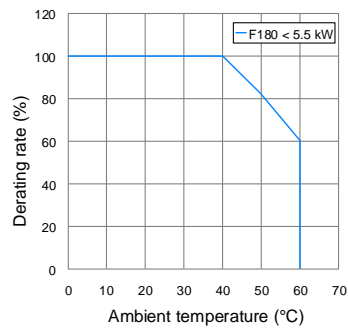
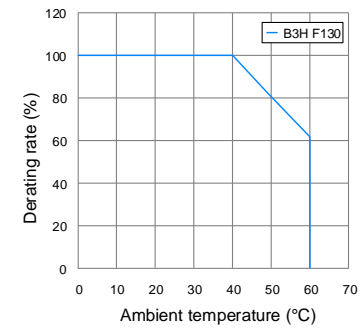
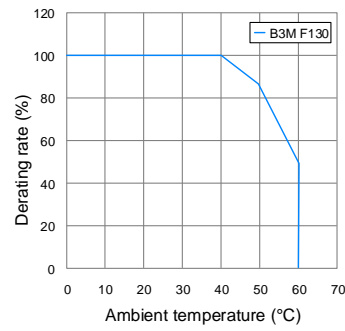
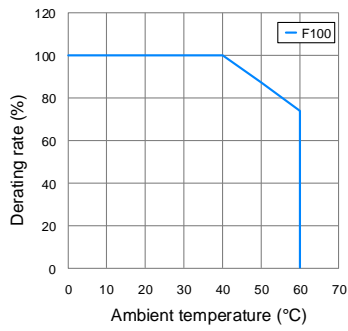
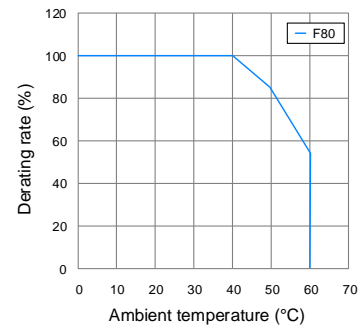
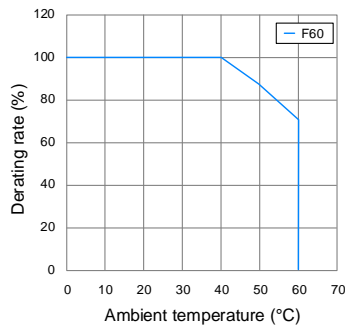
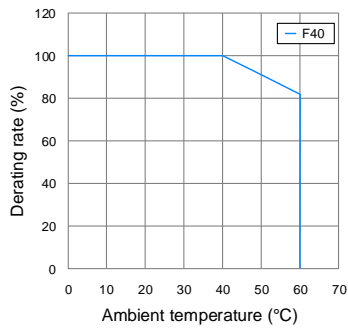

Note: the preceding specifications are applicable to 220V and 400V models.

A.2.4 Overload features

Definition of overload protection

The overload protection prevents the motor from overheating.



Causes of overload

1. The motor's operating torque exceeds the rated range and the operating time is too long.
2. The inertia ratio is too high and the motor frequently accelerates and decelerates.
3. Incorrect wiring of the power and encoder cables.
4. Incorrect servo gain setting causes resonance in the motor.
5. A motor with a built-in brake operates without the brake released.

Graph of load ratio and operating time

220V series: low inertia (ECM-B3L series), medium inertia (ECM-B3M-C series),
high inertia (ECM-B3H-C series)

400V series: medium inertia (ECM-B3M-J series)

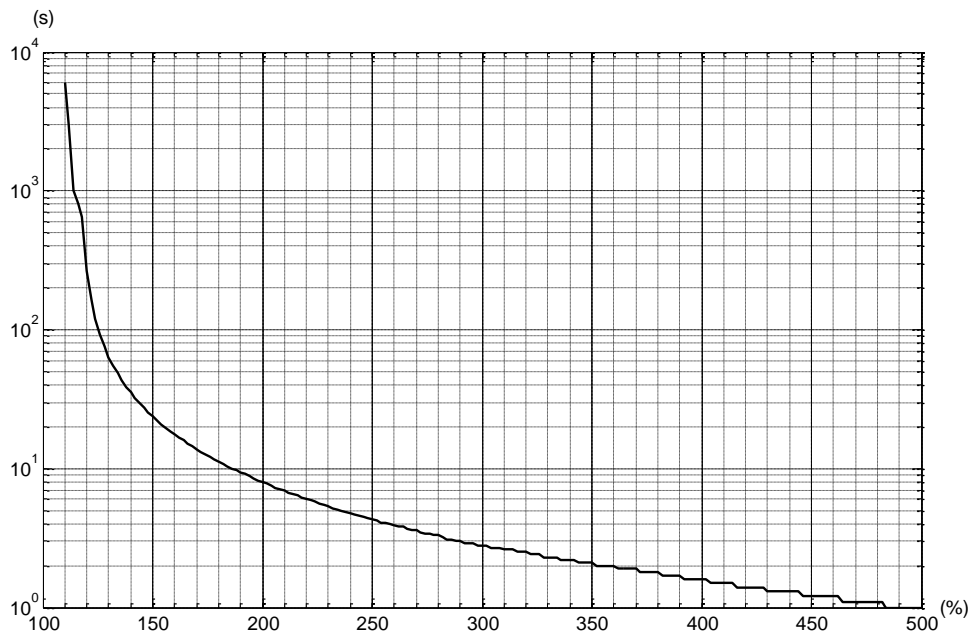

Load ratio	120%	140%	160%	180%	200%	220%	240%
Operating time	263.8 s	35.2 s	17.6 s	11.2 s	8 s	6.1 s	4.8 s
Load ratio	260%	280%	300%	350%	400%	450%	500%
Operating time	3.9 s	3.3 s	2.8 s	2.1 s	1.6 s	1.2 s	1.0 s

220V series: medium inertia (ECM-B3M-E / -F series), high inertia (ECM-B3H-F series)
 400V series: medium inertia (ECM-B3M-K / -L series), high inertia (ECM-B3H-L series)

A

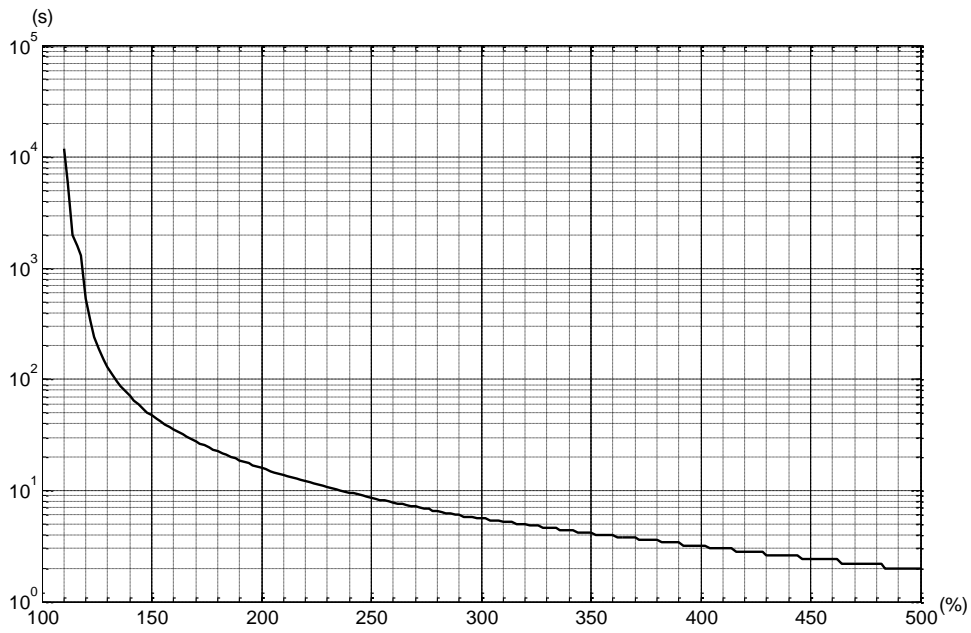

Load ratio	120%	140%	160%	180%	200%	220%	240%
Operating time	527.6 s	70.4 s	35.2 s	22.4 s	16 s	12.2 s	9.6 s
Load ratio	260%	280%	300%	350%	400%	450%	500%
Operating time	7.8 s	6.6 s	5.6 s	4.2 s	3.2 s	2.4 s	2.0 s

A.2.5 Dimensions of ECM-B3 series servo motor

A.2.5.1 220V series

Motor frame size: 80 mm and below, with cables (low & medium & high inertia)

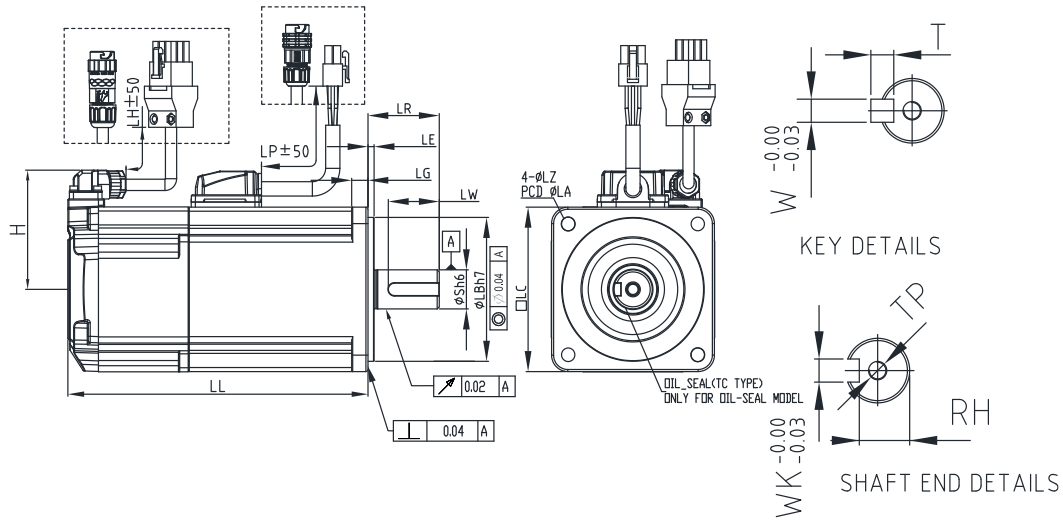

Unit: mm

ECM-	B3L-C□ 0401□S1	B3M-C□ 0602□S1	B3M-C□ 0604□S1	B3M-C□ 0804□71	B3M-C□ 0807□S1	B3M-C□ 0810□S1	B3H-C□ 0602□S1	B3H-C□ 0604□S1	B3H-C□ 0807□S1
LC	40	60	60	80	80	80	60	60	80
LZ	4.5	5.5	5.5	6.6	6.6	6.6	5.5	5.5	6.6
LA	46	70	70	90	90	90	70	70	90
S	8 ^(+0/-0.009)	14 ^(+0/-0.011)	14 ^(+0/-0.011)	14 ^(+0/-0.011)	19 ^(+0/-0.013)	19 ^(+0/-0.013)	14 ^(+0/-0.011)	14 ^(+0/-0.011)	19 ^(+0/-0.013)
LB	30 ^(+0/-0.021)	50 ^(+0/-0.025)	50 ^(+0/-0.025)	70 ^(+0/-0.030)	70 ^(+0/-0.030)	70 ^(+0/-0.030)	50 ^(+0/-0.025)	50 ^(+0/-0.025)	70 ^(+0/-0.030)
LL (w/o brake)	77.6	72.5	91	86.7	105.2	118.7	69.6	87.45	105.2
LL (with brake)	111.7	109.4	127.9	126.3	144.8	158.3	106.5	124.35	144.8
LH	300	300	300	300	300	300	300	300	300
LP	300	300	300	300	300	300	300	300	300
H	40	48.5	48.5	58.5	58.5	58.5	48.5	48.5	58.5
LR	25	30	30	30	35	35	30	30	35
LE	2.5	3	3	3	3	3	3	3	3
LG	5	7.5	7.5	8	8	8	7.5	7.5	8
LW	16	20	20	20	25	25	20	20	25
RH	6.2	11	11	11	15.5	15.5	11	11	15.5
WK	3	5	5	5	6	6	5	5	6
W	3	5	5	5	6	6	5	5	6
T	3	5	5	5	6	6	5	5	6
TP	M3 Depth 8	M4 Depth 15	M4 Depth 15	M4 Depth 15	M6 Depth 20	M6 Depth 20	M4 Depth 15	M4 Depth 15	M6 Depth 20

Note: CHOGORI (IP67) connectors are available for F80 and below models. Refer to Section A.2 for detailed model descriptions.

A

Motor frame size: 80 mm and below, with bulkhead connectors (low & medium & high inertia)

A

The motor is shipped without cables.

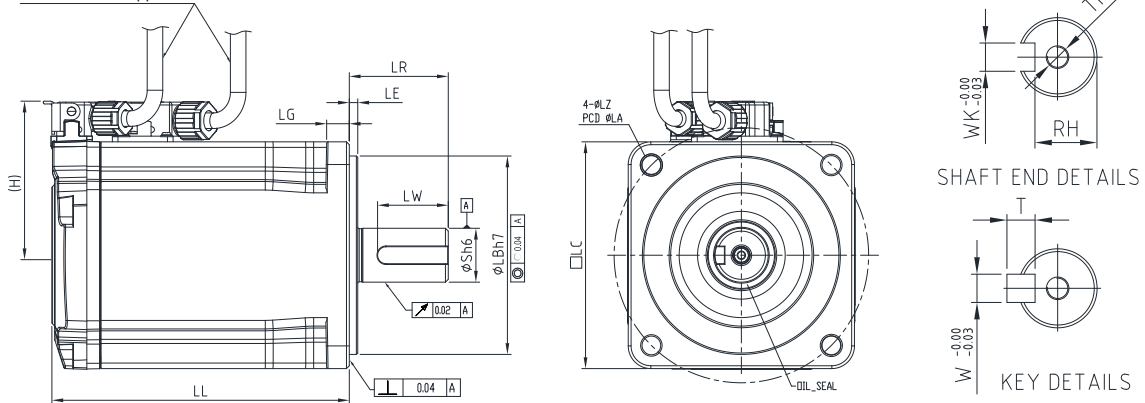

Unit: mm

ECM-	B3L-C□ 0401□B1	B3M-C□ 0602□B1	B3M-C□ 0604□B1	B3M-C□ 0807□B1	B3H-C□ 0602□B1	B3H-C□ 0604□B1	B3H-C□ 0807□B1
LC	40	60	60	80	60	60	80
LZ	4.5	5.5	5.5	6.6	5.5	5.5	6.6
LA	46	70	70	90	70	70	90
S	8 ^(+0/-0.009)	14 ^(+0/-0.011)	14 ^(+0/-0.011)	19 ^(+0/-0.013)	14 ^(+0/-0.011)	14 ^(+0/-0.011)	19 ^(+0/-0.013)
LB	30 ^(+0/-0.021)	50 ^(+0/-0.025)	50 ^(+0/-0.025)	70 ^(+0/-0.030)	50 ^(+0/-0.025)	50 ^(+0/-0.025)	70 ^(+0/-0.030)
LL (w/o brake)	76.2	72.5	91	105.2	69.6	87.45	95.4
LL (with brake)	107.7	104.4	122.9	140.8	101.5	119.35	131
LH	300	300	300	300	300	300	300
LP	300	300	300	300	300	300	300
H	34	44	44	54	44	44	54
LR	25	30	30	35	30	30	35
LE	2.5	3	3	3	3	3	3
LG	5	7.5	7.5	8	7.5	7.5	8
LW	16	20	20	25	20	20	25
RH	6.2	11	11	15.5	11	11	15.5
WK	3	5	5	6	5	5	6
W	3	5	5	6	5	5	6
T	3	5	5	6	5	5	6
TP	M3 Depth 8	M4 Depth 15	M4 Depth 15	M6 Depth 20	M4 Depth 15	M4 Depth 15	M6 Depth 20

Motor frame size: 100 mm (medium inertia)

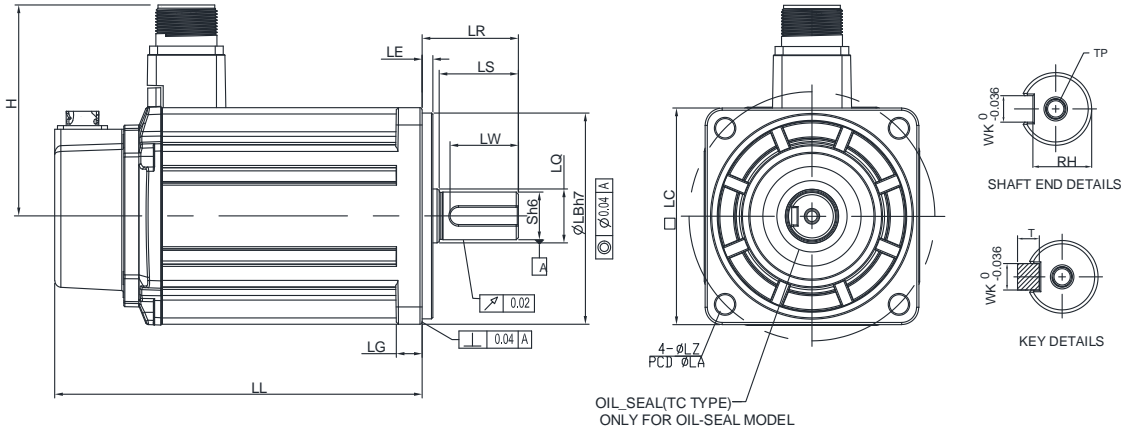

A

Unit: mm

ECM-	B3M-C□1010□S1	B3M-C□1015□S1	B3M-C□1020□S1
LC	100	100	100
LZ	9	9	9
LA	115	115	115
S	22 ^(+0/-0.013)	22 ^(+0/-0.013)	22 ^(+0/-0.013)
LB	95 ^(+0/-0.03)	95 ^(+0/-0.03)	95 ^(+0/-0.03)
LL (w/o brake)	141.8	156.8	171.8
LL (with brake)	179.9	194.9	209.9
H	97.4	97.4	97.4
LS	37	37	37
LR	45	45	45
LQ	25	25	25
LE	5	5	5
LG	12	12	12
LW	32	32	32
RH	18	18	18
WK	8	8	8
W	8	8	8
T	7	7	7
TP	M6 Depth12	M6 Depth12	M6 Depth12

Motor frame size: 130 mm (medium & high inertia)

A

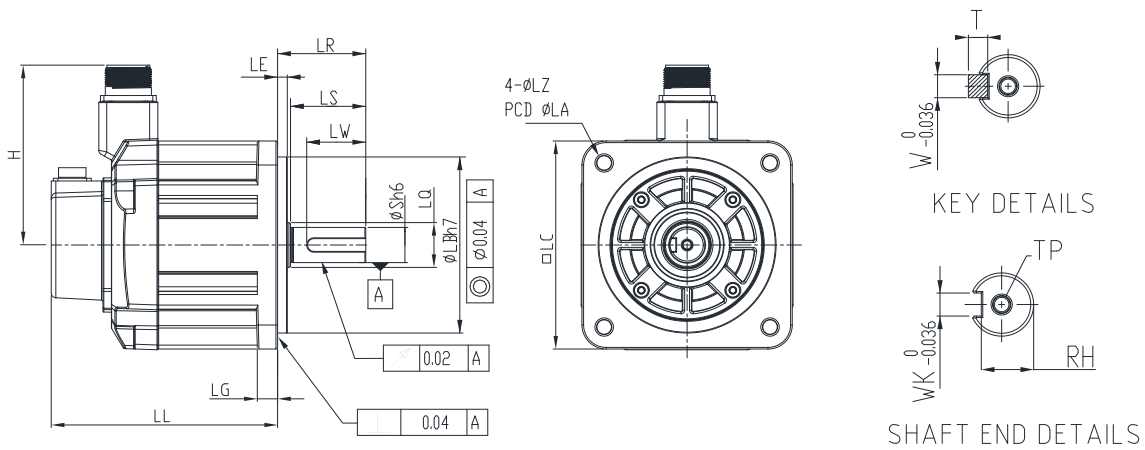

Unit: mm

ECM-	B3M-E□ 1310□S1	B3M-E□ 1315□S1	B3M-E□ 1320□S1	B3H-F□ 1308□S1	B3H-F□ 1313□S1	B3H-F□ 1318□S1
LC	130	130	130	130	130	130
LZ	9	9	9	9	9	9
LA	145	145	145	145	145	145
S	22 ⁺⁰ _{-0.013}	22 ⁺⁰ _{-0.013}	22 ⁺⁰ _{-0.013}	22 ⁺⁰ _{-0.013}	22 ⁺⁰ _{-0.013}	22 ⁺⁰ _{-0.013}
LB	110 ⁺⁰ _{-0.035}	110 ⁺⁰ _{-0.035}	110 ⁺⁰ _{-0.035}	110 ⁺⁰ _{-0.035}	110 ⁺⁰ _{-0.035}	110 ⁺⁰ _{-0.035}
LL (w/o brake)	127.9	139.9	151.9	127.9	139.9	151.9
LL (with brake)	168.5	180.5	192.5	168.5	180.5	192.5
H	115	115	115	115	115	115
LS	47	47	47	47	47	47
LR	55	55	55	55	55	55
LQ	28	28	28	28	28	28
LE	6	6	6	6	6	6
LG	12.5	12.5	12.5	12.5	12.5	12.5
LW	36	36	36	36	36	36
RH	18	18	18	18	18	18
WK	8	8	8	8	8	8
W	8	8	8	8	8	8
T	7	7	7	7	7	7
TP	M6 Depth12	M6 Depth12	M6 Depth12	M6 Depth12	M6 Depth12	M6 Depth12

Motor frame size: 180 mm (medium inertia)

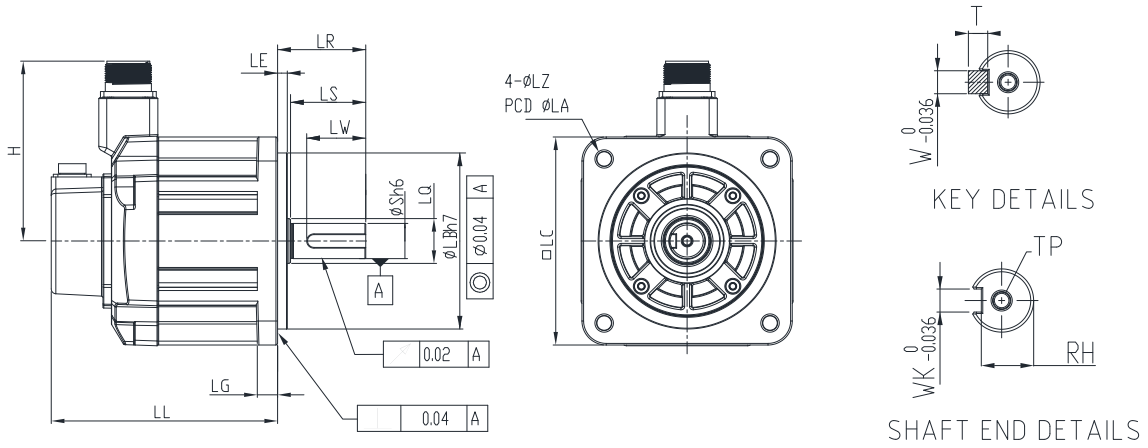

A

Unit: mm

ECM-	B3M-E□1820□S1	B3M-F□1830□S1
LC	180	180
LZ	13.5	13.5
LA	200	200
S	35 ^(+0/-0.016)	35 ^(+0/-0.016)
LB	114.3 ^(+0/-0.035)	114.3 ^(+0/-0.035)
LL (w/o brake)	137.5	160.5
LL (with brake)	189.5	212.5
H	139	139
LS	73	73
LR	79	79
LQ	45	45
LE	4	4
LG	18	18
LW	63	63
RH	30	30
WK	10	10
W	10	10
T	8	8
TP	M12 Depth25	M12 Depth25

A.2.5.2 400V series

Motor frame size: 80 mm and below, with cables (medium inertia)

A

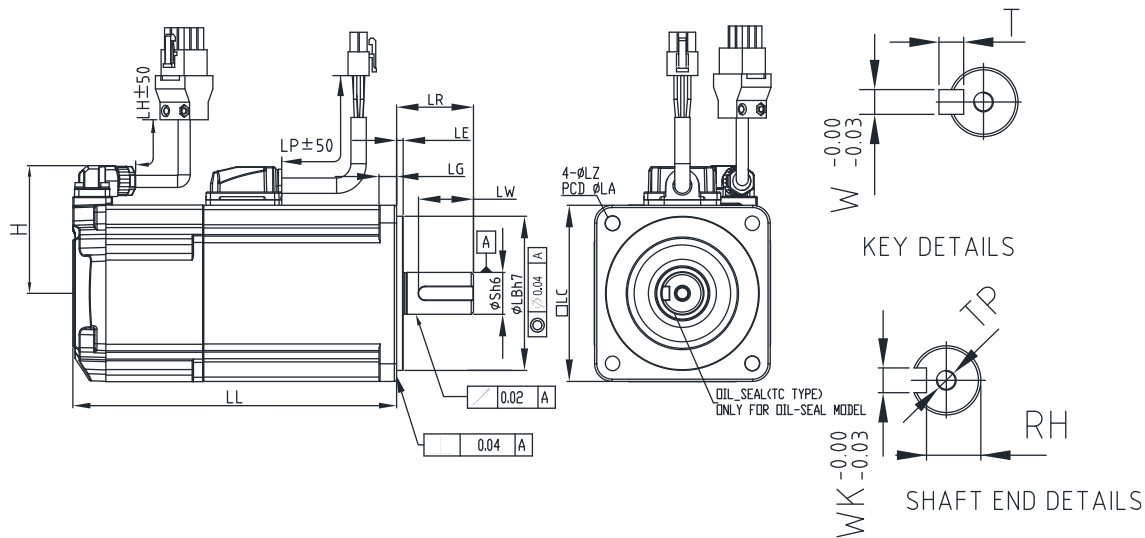

Unit: mm

ECM-	B3M-J□0807□S1
LC	80
LZ	6.6
LA	90
S	19 ^(+0/-0.013)
LB	70 ^(+0/-0.030)
LL (w/o brake)	105.2
LL (with brake)	144.8
LH	300
LP	300
H	58.5
LR	35
LE	3
LG	8
LW	25
RH	15.5
WK	6
W	6
T	6
TP	M6 Depth20

Motor frame size: 100 mm (medium inertia)

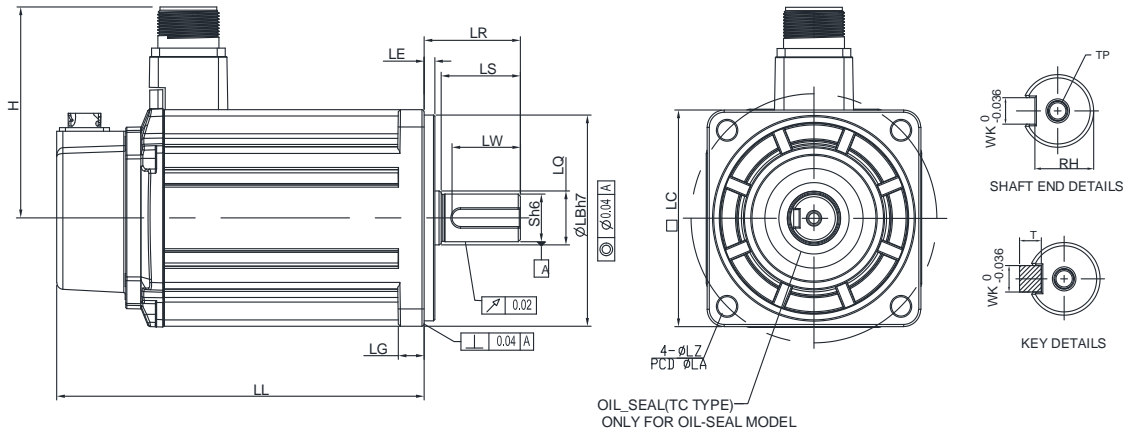

A

Unit: mm

ECM-	B3M-J□1010□S1	B3M-J□1015□S1	B3M-J□1020□S1
LC	100	100	100
LZ	9	9	9
LA	115	115	115
S	22 ^(+0/-0.013)	22 ^(+0/-0.013)	22 ^(+0/-0.013)
LB	95 ^(+0/-0.03)	95 ^(+0/-0.03)	95 ^(+0/-0.03)
LL (w/o brake)	141.8	156.8	171.8
LL (with brake)	179.9	194.9	209.9
H	97.4	97.4	97.4
LS	37	37	37
LR	45	45	45
LQ	25	25	25
LE	5	5	5
LG	12	12	12
LW	32	32	32
RH	18	18	18
WK	8	8	8
W	8	8	8
T	7	7	7
TP	M6 Depth12	M6 Depth12	M6 Depth12

Motor frame size: 180 mm (medium inertia)

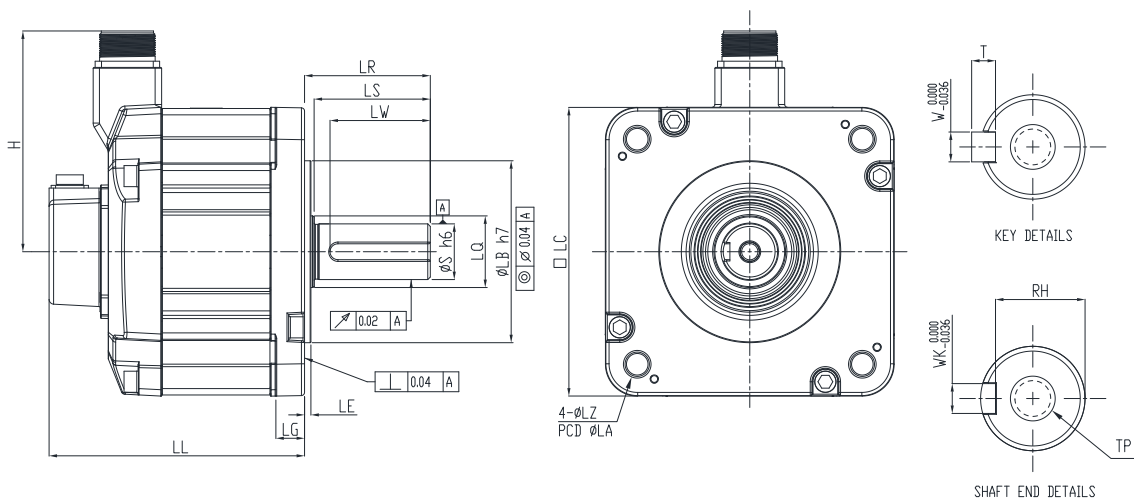

A

Unit: mm

ECM-	B3M-K□1820□S1	B3M-L□1830□S1	B3M-L□1845□S1	B3M-L□1855□31	B3M-L□1875□31
LC	180	180	180	180	180
LZ	13.5	13.5	13.5	13.5	13.5
LA	200	200	200	200	200
S	35 ^(+0/-0.016)	35 ^(+0/-0.016)	35 ^(+0/-0.016)	42 ^(+0/-0.016)	42 ^(+0/-0.016)
LB	114.3 ^(+0/-0.035)	114.3 ^(+0/-0.035)	114.3 ^(+0/-0.035)	114.3 ^(+0/-0.035)	114.3 ^(+0/-0.035)
LL (w/o brake)	137.5	160.5	174	218	260.1
LL (with brake)	189.5	212.5	226	265	307.1
H	139	139	139	144.5	144.5
LS	73	73	73	108.5	108.5
LR	79	79	79	113	113
LQ	45	45	45	45	45
LE	4	4	4	4	4
LG	18	18	18	18	18
LW	63	63	63	90	90
RH	30	30	30	37	37
WK	10	10	10	12	12
W	10	10	10	12	12
T	8	8	8	8	8
TP	M12 Depth25	M12 Depth25	M12 Depth25	M16 Depth32	M16 Depth32

A.3 ECM-A3 series servo motor

ECM-A3 series servo motor

A

$$\frac{\text{ECM}}{(1)} - \frac{\text{A}}{(2)} \frac{\text{3}}{(3)} \frac{\text{L}}{(4)} - \frac{\text{C}}{(5)} \frac{\text{2}}{(6)} \frac{\text{06}}{(7)} \frac{\text{04}}{(8)} \frac{\text{R}}{(9)} \frac{\text{S}}{(10)} \frac{\text{1}}{(11)}$$

(1) Product name

ECM: electronically commutated motor

(2) Servo type

A: high-precision servo motor

(3) Series

3: 3rd series

(4) Inertia

H: high inertia

L: low inertia

(5) Rated voltage and speed

C: 220V and 3,000 rpm

(6) Encoder type

Y: 24-bit absolute optical encoder

(resolution of single turn: 24-bit; number of revolutions: 16-bit)

1: 24-bit incremental optical encoder (single-turn absolute)

A: 24-bit absolute optical encoder

(resolution of single turn: 24-bit; number of revolutions: 16-bit)

2: 24-bit incremental optical encoder (single-turn absolute)

Note: number of revolutions means the maximum number of turns the encoder can record.

(7) Motor frame size

Code	Specification	Code	Specification
04	40 mm	08	80 mm
06	60 mm	-	-

A

(8) Rated power output

Code	Specification	Code	Specification
0F	50 W	04	400 W
01	100 W	07	750 W
02	200 W	-	-

(9) Shaft type and oil seal

	w/o brake, with oil seal	with brake, with oil seal
Keyway (with fixed screw holes)	R	S

(10) Shaft diameter and connector type

S: standard shaft diameter and standard connectors

7: special shaft diameter (14 mm)* and standard connectors

J: standard shaft diameter and CHOGORI (IP67) connectors

K: special shaft diameter (14 mm)* and CHOGORI (IP67) connectors

Note: special shaft diameter is available for F80 400 W models.

(11) Special code

1: standard products

Z: special code of C²0807³S⁵. Refer to the note in Section A.3.5.

Note: the model codes listed here are only for demonstration of the naming convention; some combinations of the model codes are not available. Contact the distributors for the model numbers available for purchase.

A.3.1 ECM-A3L low inertia series servo motor

A

ECM-A3L-	C□040F	C□0401	C□0602	C□0604	C□0804	C□0807	
Rated power (kW)	0.05	0.1	0.2	0.4	0.4	0.75	
Rated torque (N·m) ^{*1}	0.159	0.32	0.64	1.27	1.27	2.39	
Max. torque (N·m)	0.557	1.12	2.24	4.45	4.44	8.36	
Rated speed (rpm)	3000						
Max. speed (rpm)	6000						
Rated current (Arms)	0.66	0.9	1.45	2.65	2.6	5.1	
Max. instantaneous current (Arms)	2.82	3.88	6.2	10.1	10.6	20.6	
Change of rated power (kW/s)	w/o brake	11	25.6	45.5	107.5	45.8	102.2
	with brake	9.9	24	34.1	89.6	39.5	93
Rotor inertia (× 10 ⁻⁴ kg·m ²)	w/o brake	0.0229	0.04	0.09	0.15	0.352	0.559
	with brake	0.0255	0.0426	0.12	0.18	0.408	0.614
Mechanical time constant (ms)	w/o brake	1.28	0.838	0.64	0.41	0.68	0.44
	with brake	1.44	0.892	0.85	0.5	0.78	0.48
Torque constant-KT (N·m/Arms)	0.241	0.356	0.441	0.479	0.488	0.469	
Voltage constant-KE (mVrms/rpm)	9.28	13.3	16.4	18	17.9	17	
Armature resistance (Ohm)	12.1	9.47	4.9	2.27	1.6	0.6	
Armature inductance (mH)	18.6	16.2	18.52	10.27	10.6	4.6	
Electrical time constant (ms)	1.54	1.71	3.78	4.52	6.63	7.67	
Weight (kg)	w/o brake	0.38	0.5	1.1	1.4	2.05	2.8
	with brake	0.68	0.8	1.6	1.9	2.85	3.6
Max. radial load (N)	78	78	245	245	392	392	
Max. axial load (N)	54	54	74	74	147	147	
Brake operating voltage	24 V _{DC} ± 10%						
Brake power consumption (W) (at 20°C (68°F))	6.1	6.1	7.2	7.2	8	8	
Brake holding torque [N·m (Min)] ^{*2}	0.32	0.32	1.3	1.3	2.5	2.5	
Brake release time [ms (Max)]	20	20	20	20	20	20	
Brake pull-in time [ms (Max)]	35	35	50	50	60	60	
Derating rate with oil seal (%)	20	10	10	5	5	5	
Insulation class	Class A (UL), Class B (CE)						
Insulation resistance	100 MΩ min. (at 500 V _{DC})						
Insulation strength	1.8 kV _{AC} , 1 sec						
Vibration grade	V15						
Operating temperature	0°C to 40°C (32°F to 104°F)						
Storage temperature	-10°C to +80°C (14°F to 176°F)						
Operating and storage humidity	20 - 90% RH (non-condensing)						
Vibration capacity	2.5 G						
IP rating	IP67 (for models using waterproof connectors and shaft seals or oil seals)						
Approvals							

Note:

1. The rated torque is the continuous permissible torque between 0°C - 40°C (32°F - 104°F) ambient temperature which is suitable for the servo motor mounted with the heat sink of the following dimensions.

F40, F60, and F80: 250 mm x 250 mm x 6 mm

Material: aluminum

2. The built-in servo motor brake is only for keeping the object in a stopped state. Do not use it for deceleration or as a dynamic brake.

A

A.3.2 ECM-A3H high inertia series servo motor

A

ECM-A3H-	C□040F	C□0401	C□0602	C□0604	C□0804	C□0807	
Rated power (kW)	0.05	0.1	0.2	0.4	0.4	0.75	
Rated torque (N·m) ^{*1}	0.159	0.32	0.64	1.27	1.27	2.39	
Max. torque (N·m)	0.557	1.12	2.24	4.45	4.44	8.36	
Rated speed (rpm)	3000						
Max. speed (rpm)	6000						
Rated current (Arms)	0.64	0.9	1.45	2.65	2.6	4.61	
Max. instantaneous current (Arms)	2.59	3.64	5.3	9.8	9.32	16.4	
Change of rated power (kW/s)	w/o brake	5.56	13.6	16.4	35.8	17.5	37.8
	with brake	4.89	12.5	14.6	33.6	15.07	34.41
Rotor inertia (× 10 ⁻⁴ kg·m ²)	w/o brake	0.0455	0.0754	0.25	0.45	0.92	1.51
	with brake	0.0517	0.0816	0.28	0.48	1.07	1.66
Mechanical time constant (ms)	w/o brake	2.52	1.43	1.38	0.96	1.32	0.93
	with brake	2.86	1.55	1.54	1.02	1.54	1.02
Torque constant-KT (N·m/Arms)	0.248	0.356	0.441	0.479	0.49	0.52	
Voltage constant-KE (mVrms/rpm)	9.54	12.9	16.4	17.2	17.9	18.7	
Armature resistance (Ohm)	12.5	8.34	3.8	1.68	1.19	0.57	
Armature inductance (mH)	13.34	11	8.15	4.03	4.2	2.2	
Electrical time constant (ms)	1.07	1.32	2.14	2.40	3.53	3.86	
Weight (kg)	w/o brake	0.38	0.5	1.1	1.4	2.05	2.8
	with brake	0.68	0.8	1.6	1.9	2.85	3.6
Max. radial load (N)	78	78	245	245	392	392	
Max. axial load (N)	54	54	74	74	147	147	
Brake operating voltage	24 V _{DC} ± 10%						
Brake power consumption (W) (at 20°C (68°F))	6.1	6.1	7.2	7.2	8	8	
Brake holding torque [N·m (Min)] ^{*2}	0.32	0.32	1.3	1.3	2.5	2.5	
Brake release time [ms (Max)]	20	20	20	20	20	20	
Brake pull-in time [ms (Max)]	35	35	50	50	60	60	
Derating rate with oil seal (%)	20	10	10	5	5	5	
Insulation class	Class A (UL), Class B (CE)						
Insulation resistance	100 MΩ min. (at 500 V _{DC})						
Insulation strength	1.8 kV _{AC} , 1 sec						
Vibration grade	V15						
Operating temperature	0°C to 40°C (32°F to 104°F)						
Storage temperature	-10°C to +80°C (14°F to 176°F)						
Operating and storage humidity	20 - 90% RH (non-condensing)						
Vibration capacity	2.5 G						
IP rating	IP67 (for models using waterproof connectors and shaft seals or oil seals)						
Approvals							

Note:

1. The rated torque is the continuous permissible torque between 0°C - 40°C (32°F - 104°F) ambient temperature which is suitable for the servo motor mounted with the heat sink of the following dimensions.

F40, F60, and F80: 250 mm x 250 mm x 6 mm

Material: aluminum

2. The built-in servo motor brake is only for keeping the object in a stopped state. Do not use it for deceleration or as a dynamic brake.

A

A.3.3 Torque features (T-N curves) of the A3 motors

A

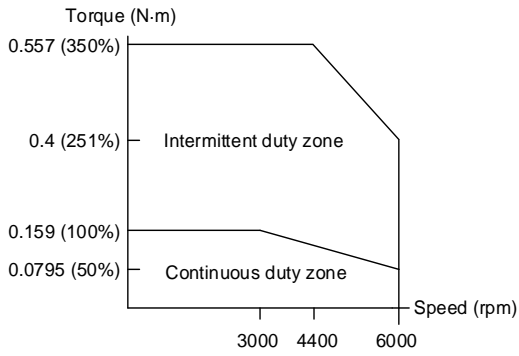

ECM-A3L-C2040F345

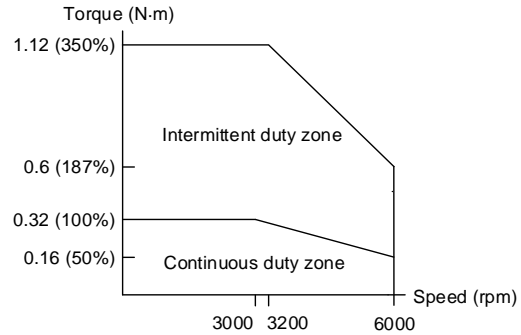

ECM-A3L-C20401345

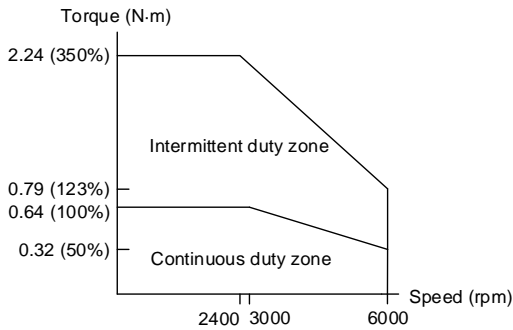

ECM-A3L-C20602345

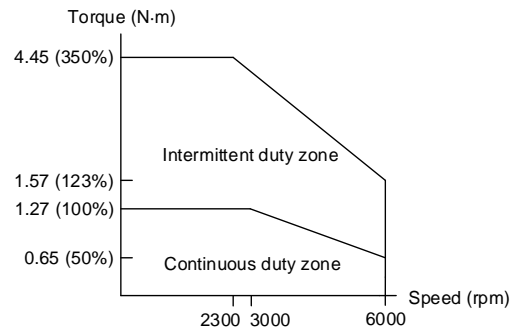

ECM-A3L-C20604345

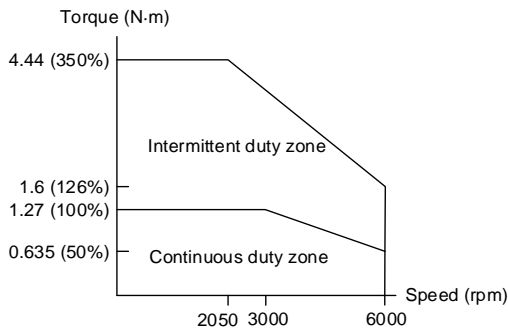

ECM-A3L-C20804345

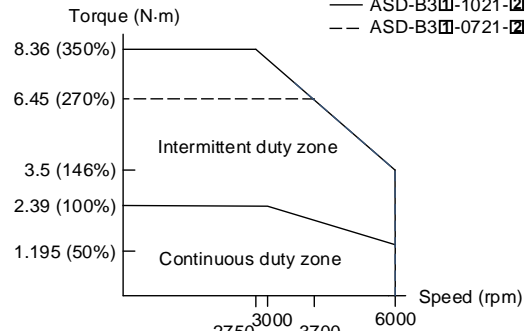

ECM-A3L-C20807345

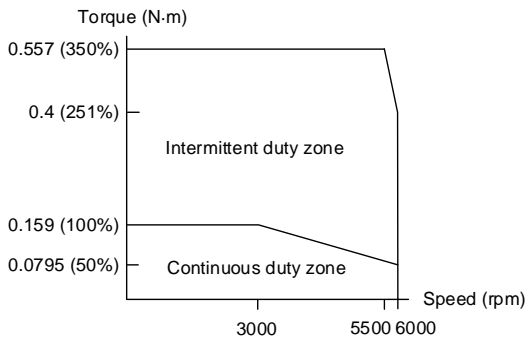

ECM-A3H-C2040F345

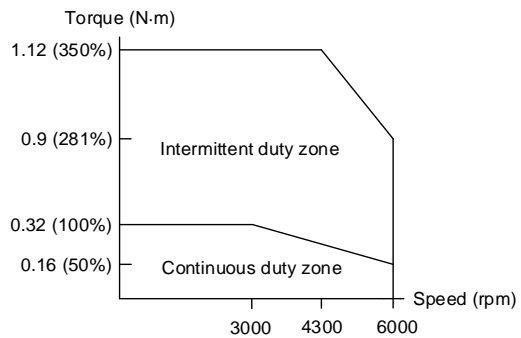

ECM-A3H-C20401345

A

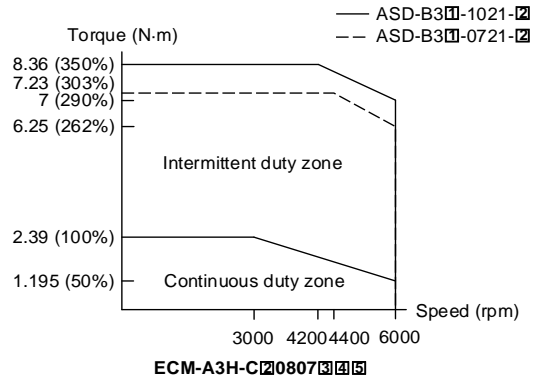
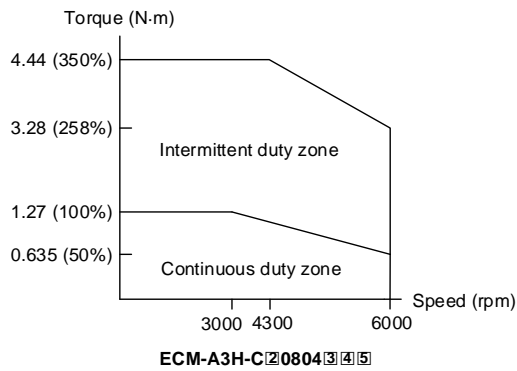
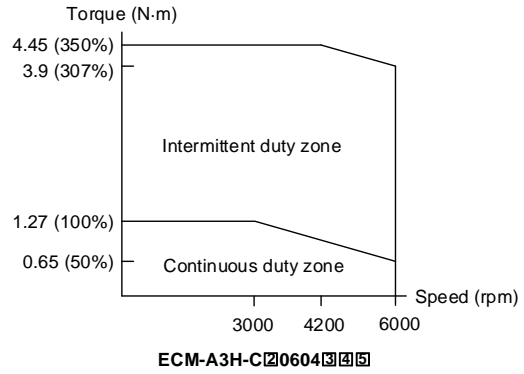
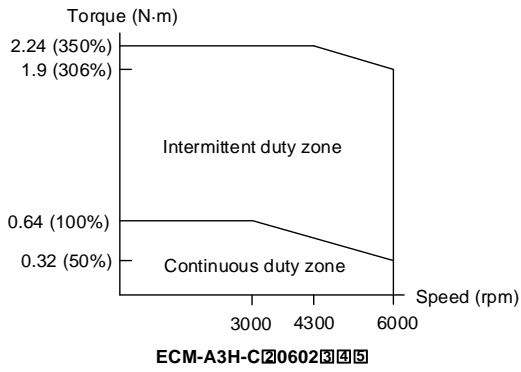

Note: in the servo motor model number, [2] represents the encoder type; [3] represents the brake or keyway / oil seal type; [4] represents the shaft diameter and connector type; and [5] represents the special code.

A.3.4 Overload features

Definition of overload protection

The overload protection prevents the motor from overheating.

Causes of overload

1. The motor's operating torque exceeds the rated range and the operating time is too long.
2. The inertia ratio is too high and the motor frequently accelerates and decelerates.
3. Incorrect wiring of the power and encoder cables.
4. Incorrect servo gain setting causes resonance in the motor.
5. A motor with a built-in brake operates without the brake released.

Graph of load ratio and operating time

Low inertia (ECM-A3L series), high inertia (ECM-A3H series)

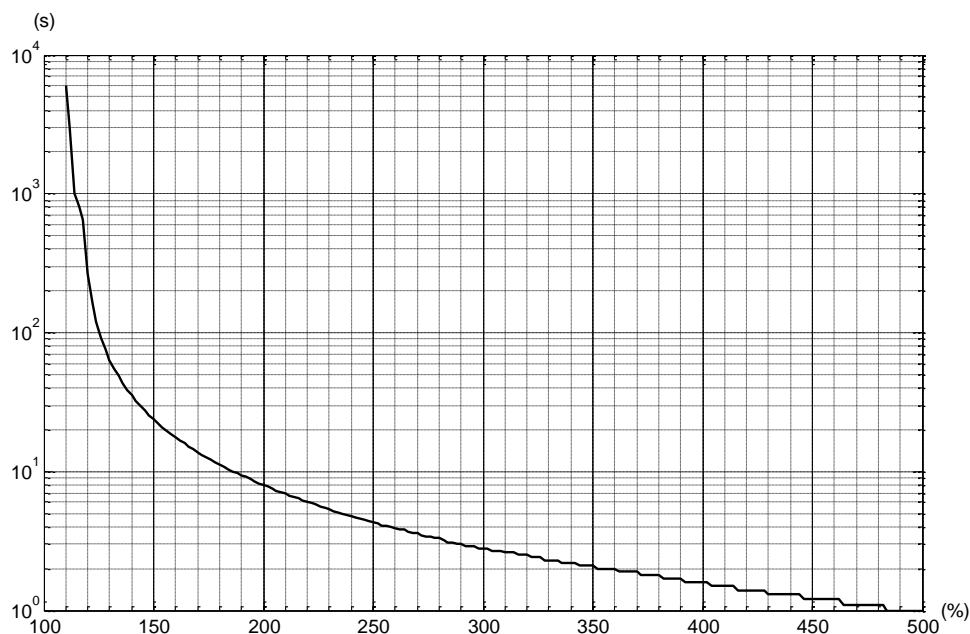

Load ratio	120%	140%	160%	180%	200%	220%	240%
Operating time	263.8 s	35.2 s	17.6 s	11.2 s	8 s	6.1 s	4.8 s
Load ratio	260%	280%	300%	350%	400%	450%	500%
Operating time	3.9 s	3.3 s	2.8 s	2.1 s	1.6 s	1.2 s	1.0 s

A.3.5 Dimensions of ECM-A3L / A3H series servo motor

Motor frame size: 80 mm and below

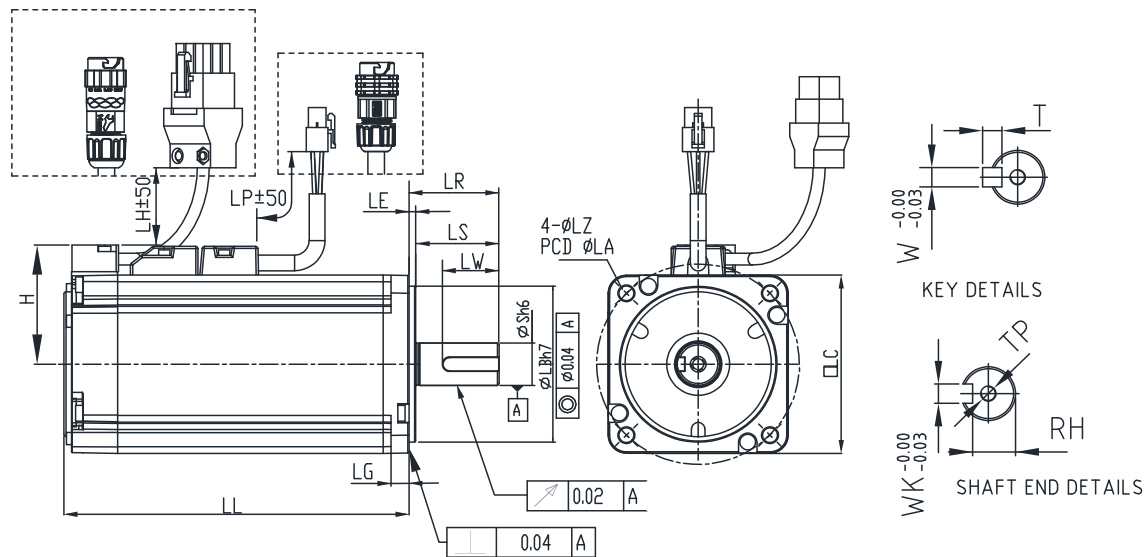

Unit: mm

ECM-A3L ECM-A3H	C□040F□□□	C□0401□□□	C□0602□□□	C□0604□□□	C□0804□□□	C□0807□□□
LC	40	40	60	60	80	80
LZ	4.5	4.5	5.5	5.5	6.6	6.6
LA	46	46	70	70	90	90
S	8 ⁽⁺⁰⁾ _(-0.009)	8 ⁽⁺⁰⁾ _(-0.009)	14 ⁽⁺⁰⁾ _(-0.011)	14 ⁽⁺⁰⁾ _(-0.011)	14 ⁽⁺⁰⁾ _(-0.011)	19 ⁽⁺⁰⁾ _(-0.013)
LB	30 ⁽⁺⁰⁾ _(-0.021)	30 ⁽⁺⁰⁾ _(-0.021)	50 ⁽⁺⁰⁾ _(-0.025)	50 ⁽⁺⁰⁾ _(-0.025)	70 ⁽⁺⁰⁾ _(-0.030)	70 ⁽⁺⁰⁾ _(-0.030)
LL (w/o brake)	70.6	85.3	84	106	93.7	115.8
LL (with brake)	105.4	120.1	117.6	139.7	131.2	153.2
LH	300	300	300	300	300	300
LP	300	300	300	300	300	300
H	34	34	43.5	43.5	54.5	54.5
LS	21.5	21.5	27	27	27	37
LR	25	25	30	30	30	40
LE	2.5	2.5	3	3	3	3
LG	5	5	7.5	7.5	8	8
LW	16	16	20	20	20	25
RH	6.2	6.2	11	11	11	15.5
WK	3	3	5	5	5	6
W	3	3	5	5	5	6
T	3	3	5	5	5	6
TP	M3 Depth 6	M3 Depth 6	M4 Depth 8	M4 Depth 8	M4 Depth 8	M6 Depth 10

Note:

1. When the special code (■) of C□0807□S■ is Z, LS = 32 and LR = 35.
2. CHOGORI (IP67) connectors are available for F80 and below models. Refer to Section A.3 for detailed model descriptions.