

Right choice for ultimate yield

LSIS strives to maximize customers' profit in gratitude of choosing us for your partner.

SV-iP5A User Manual

5.5-30 kW [200V] / 2.2-450kW [400V]



Safety Instructions

- Read this manual carefully before installing, wiring, operating, servicing or inspecting this equipment.
- Keep this manual within easy reach for quick reference.

LS Industrial Systems

Thank you for purchasing LS Variable Frequency Drives!

SAFETY INSTRUCTIONS

To prevent injury and property damage, follow these instructions during the installation and operation of the inverter.

Incorrect operation due to ignoring these instructions may cause harm or damage. The following symbols are used throughout the manual to highlight important information.



DANGER

This symbol indicates death or serious injury can occur if you do not follow instructions.



WARNING

This symbol indicates the possibility of death or serious injury.



CAUTION

This symbol indicates the possibility of damage to the inverter or other components.

■ The meaning of each symbol in this manual and on your equipment is as follows.



This is the safety alert symbol.

Read and follow instructions carefully to avoid a dangerous situation.



This symbol alerts the user to the presence of “dangerous voltage” inside the product that might cause bodily harm or electric shock.

■ This manual should be placed in a location where it can be accessed by users.

■ This manual should be given to the person who actually uses the inverter and is responsible for its maintenance.



WARNING

- **Do not remove the cover while power is applied or the unit is in operation.**
Otherwise, electric shock could occur.
- **Do not operate the inverter with the front cover removed.**
Otherwise, electric shock can occur due to the exposed terminals and bus bars.
- **Do not remove the cover except for periodic inspections or wiring, even if the input power is not applied.**
Otherwise, electric shock can occur due to accessing capacitor banks.
- **Wiring and periodic inspections should be performed at least 10 minutes after disconnecting the input power and after checking the DC link voltage is discharged with a meter (below 30VDC).**
Otherwise, electric shock could occur.
- **Operate the switches with dry hands.**
Otherwise, electric shock could occur.
- **Do not use the cable when its insulating tube is damaged.**
Otherwise, electric shock could occur.
- **Do not subject the cables to scratches, excessive stress, heavy loads or pinching.**
Otherwise, electric shock could occur.



CAUTION

- **Install the inverter on a non-flammable surface. Do not place flammable materials nearby.**
Otherwise, fire could occur.
- **Disconnect the input power if the inverter has been damaged.**
Otherwise, it could result in a secondary accident and fire.
- **Do not touch the inverter after shutting down or disconnecting it. It will remain hot for a couple of minutes.**
Otherwise, bodily injuries such as skin-burn or damage could occur.
- **Do not apply power to a damaged inverter or to an inverter with parts missing even if the installation is complete.**
Otherwise, electric shock could occur.

- **Do not allow lint, paper, wood chips, dust, metallic chips or other foreign material into the drive.**
Otherwise, fire or accident could occur.

OPERATING PRECAUTIONS

(1) Handling and installation

- The iP5A series inverter can be heavy. Lift according to the weight of the product. Use a hoist or crane to move and install the iP5A series inverter if necessary. Failure to do so may result in personal injury or damage to the inverter.
- Do not stack the inverter boxes higher than the number recommended.
- Install the inverter according to instructions specified in this manual.
- Do not open the cover during delivery.
- Do not place heavy items on the inverter.
- Check that the inverter mounting orientation is correct.
- Do not drop the inverter, or subject it to hard impact.
- Verify the ground impedance 100ohm or less for 230 V Class inverters and 10ohm or less for 460V class inverters.
- Take protective measures against ESD (Electrostatic Discharge) before touching the pcb boards during inspection, installation or repair.
- The inverter is designed for use under the following environmental conditions:

Environment	Ambient temp.	- 10 ~ 40 °C (14°F ~ 104°F)
	Relative humidity	90% Relative Humidity or less (non-condensing)
	Storage temp.	- 20 ~ 65 °C (-4°F ~ 149°F)
	Location	Protected from corrosive gas, combustible gas, oil mist or dust (Pollution Degree 2 Environment)
	Altitude, Vibration	Max. 1,000m (3,300ft) above sea level, Max. 5.9m/sec ² (0.6G) or less
	Atmospheric pressure	70 ~ 106 kPa (20.67 in Hg ~ 31.3 in Hg)

(2) Wiring

- Do not connect power factor correction capacitors, surge suppressors, or RFI filter to the output of the inverter.
- The connection orientation of the motor output cables U, V, W will affect the direction of rotation of the motor. Verify correct wiring before starting inverter.
- Incorrect terminal wiring could result in inverter and/or equipment damage.
- Reversing the polarity (+/-) of the terminals could damage the inverter.
- Only authorized personnel familiar with LS inverter should perform wiring and inspections.
- Always install the inverter before wiring. Otherwise, electric shock or bodily injury can occur.

(3) Trial run

- Check all parameters during operation. Parameter values might require adjustment depending on the application.
- Always apply voltage within the permissible range of each terminal as indicated in this manual. Otherwise, inverter damage may result.

(4) Operation precautions

- When the Auto restart function is selected, the inverter will restart after a fault has occurred.
- The Stop key on the keypad can only be used to stop the inverter when keypad control is enabled. Install a separate emergency stop switch if necessary.
- If a fault reset is made with the run command and /or reference signal present, a sudden start will occur. Check that the run command and /or reference signal is turned off in advance of resetting any faults. Otherwise an accident could occur.
- Do not modify the inverter.
- Depending on the motor specifications and user ETH overload settings, the motor may not be protected by electronic thermal function of inverter.
- The operation of the inverter is intended to be controlled by either keypad command or control input signals. Do not use a magnetic contactor or any other device that routinely disconnects the inverter and reconnects the inverter to the input supply power for the purpose of starting and stopping the motor.
- A noise filter may be installed to reduce the effect of electromagnetic interference. Otherwise nearby electronic equipment may be affected.
- In cases with input voltage unbalances, install an AC input reactor.
- Power Factor capacitors and generators may become overheated and damaged due to harmonics created by the inverter.
- Use an insulation-rectified motor or take measures to suppress the micro surge voltage when driving 460V class motor with inverter. A micro surge voltage attributable to wiring constant is generated at motor terminals, and may deteriorate insulation and damage motor.
- Before operating unit and prior to user programming, reset user parameters to default settings.
- The Inverter can be set to operate a motor at high-speeds. Verify the speed capability of motor and machinery prior to operating inverter.
- Holding torque is not produced when using the DC-Brake function. Install separate equipment when holding torque is required.

(5) Fault prevention precautions

- If required, provide a safety backup such as an emergency mechanical brake to prevent any hazardous conditions if the inverter fails during operation.

(6) Maintenance, inspection and parts replacement

- Do not megger (hi-pot or insulation resistance) test the power or control circuit of the inverter.
- Refer to Chapter 8 for periodic inspection and parts replacement details.

(7) Disposal

- Handle the inverter as an industrial waste when disposing of it.

(8) General instructions

Many of the diagrams and drawings in this instruction manual show the inverter without a cover. Prior to operating the unit, be sure to restore covers and circuit protection according to specifications.

Table of Contents

CHAPTER 1 - BASIC INFORMATION	1-1
1.1 INSPECTION	1-1
1.2 BASIC CONFIGURATION	1-2
CHAPTER 2 - SPECIFICATION	2-1
2.1 200~230V CLASS (5.5~30kW / 7.5~40HP)	2-1
2.2 380~480V CLASS (5.5~30kW / 7.5~40HP)	2-1
2.3 380 ~ 480V CLASS (37~90kW / 50~125HP)	2-2
2.4 380 ~ 480V CLASS (110~450kW / 150~600HP)	2-2
2.5 DIMENSIONS.....	2-5
CHAPTER 3 - INSTALLATION	3-1
3.1 INSTALLATION PRECAUTIONS	3-1
3.2 WIRING	3-3
CHAPTER 4 - OPERATION	4-1
4.1 PROGRAMMING KEYPADS	4-1
1.1 SET.....	4-2
4.2 OPERATING EXAMPLE	4-6
4.3 VARIOUS FUNCTION SETTING & DESCRIPTION.....	4-11
4.4 OPERATION EXAMPLE	4-17
CHAPTER 5 - PARAMETER LIST	5-1
5.1 PARAMETER GROUPS	5-1
5.2 PARAMETER LIST	5-2
CHAPTER 6 - PARAMETER DESCRIPTION.....	6-1
6.1 DRIVE GROUP [DRV]	6-1
6.2 FUNCTION 1 GROUP [FU1]	6-10
6.3 FUNCTION 2 GROUP [FU2]	6-24
6.4 INPUT/OUTPUT GROUP [I/O]	6-37
6.5 APPLICATION GROUP [APP].....	6-56
CHAPTER 7 - TROUBLESHOOTING & MAINTENANCE.....	7-1
7.1 FAULT DISPLAY	7-1
FAULT REMEDY.....	7-3
7.2 TROUBLESHOOTING.....	7-5
7.3 HOW TO CHECK POWER COMPONENTS	7-6
7.4 MAINTENANCE	7-8
CHAPTER 8 - OPTIONS.....	8-1
8.1 OPTION LIST.....	8-1
8.2 EXTERNAL OPTIONS	8-2
CHAPTER 9 - RS485 COMMUNICATION	9-1
9.1 INTRODUCTION.....	9-1
9.2 SPECIFICATION.....	9-2
9.3 OPERATION.....	9-3
9.4 COMMUNICATION PROTOCOL (RS485)	9-4

9.5 PARAMETER CODE LIST	9-8
9.6 TROUBLESHOOTING	9-12
9.7 ASCII CODE LIST.....	9-14
APPENDIX A- UL MARKING	I
APPENDIX B- PERIPHERAL DEVICES.....	IV
APPENDIX C- RELATED PARAMETERS	VI
DECLARATION OF CONFORMITY	VII
EMI / RFI POWER LINE FILTERS	IX

CHAPTER 1 - BASIC INFORMATION

1.1 Inspection

- Remove the inverter from its packing and inspect its exterior for shipping damage. If damage is apparent notify the shipping agent and your LSIS sales representative.
- Remove the cover and inspect the inverter for any apparent damage or foreign objects. Ensure that all mounting hardware and terminal connection hardware is properly seated, securely fastened, and undamaged.
- Check the nameplate on the iP5A inverter. Verify that the inverter unit is the correct horsepower and input voltage for the application.

1.1.1 Inverter model number

The numbering system of the inverter is as shown below.

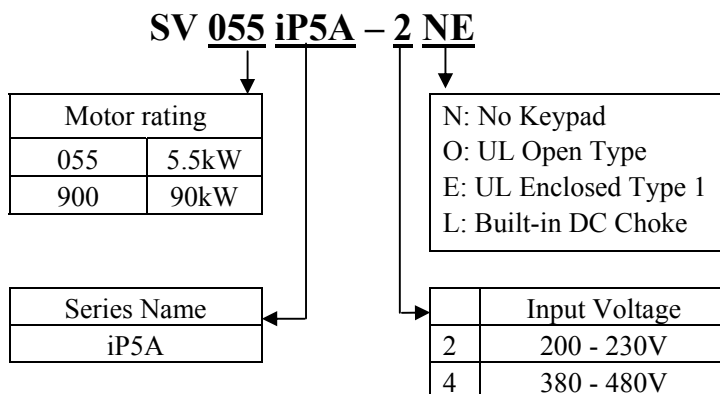

1.1.2 Installation

To operate the inverter reliably, install the inverter in a proper place with the correct direction and with the proper clearances.

1.1.3 Wiring

Connect the power supply, motor and operation signals (control signals) to the terminal block. Note that incorrect connection may damage the inverter and peripheral devices.

1.2 Basic configuration

The following devices are required to operate the inverter. Proper peripheral devices must be selected and correct connections made to ensure proper operation. An incorrectly applied or installed inverter can result in system malfunction or reduction in product life as well as component damage. You must read and understand this manual thoroughly before proceeding.

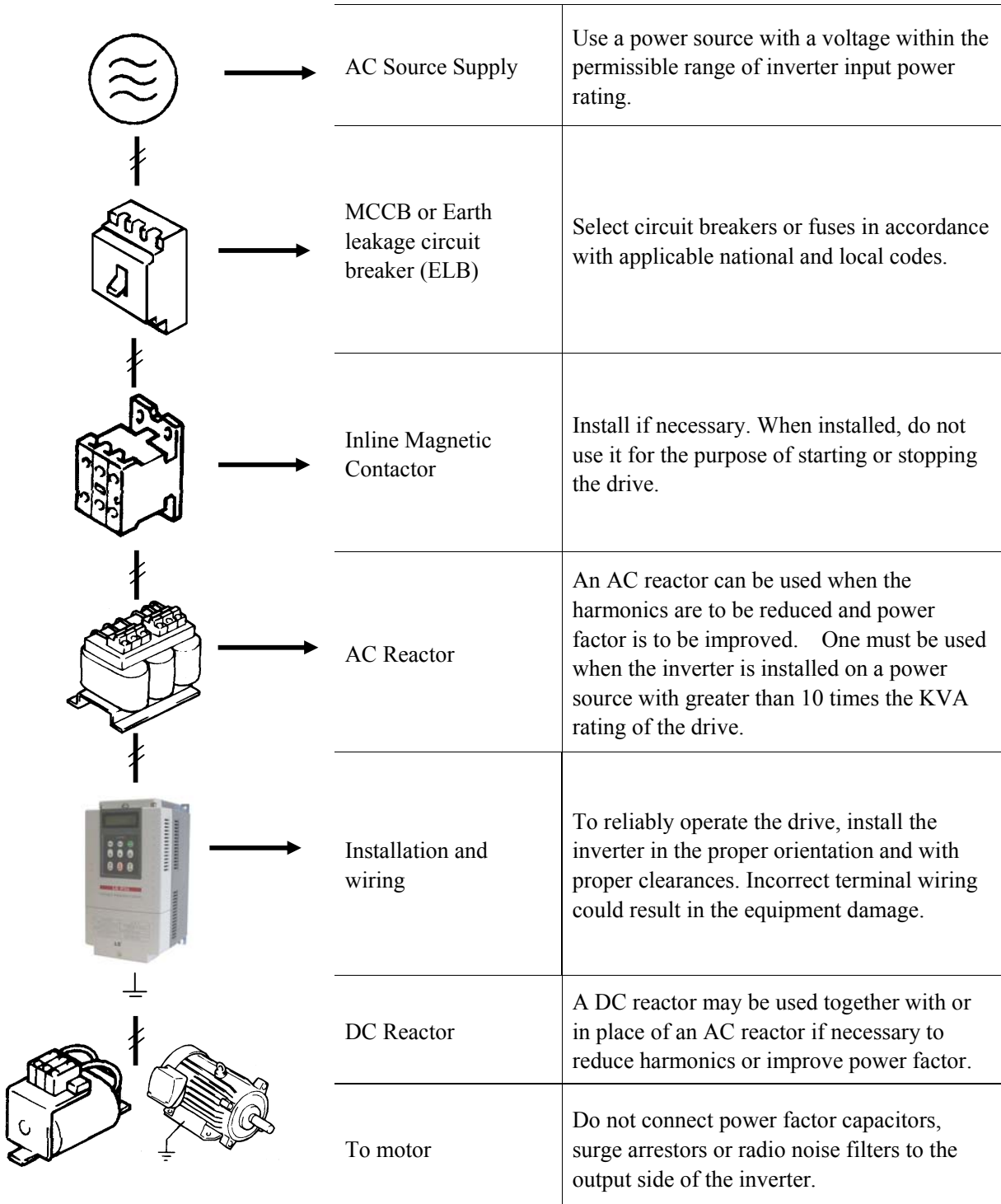

CHAPTER 2 - SPECIFICATION

2.1 200~230V Class (5.5~30kW / 7.5~40HP)

Model Number (SVxxxIP5A-2)				055	075	110	150	185	220	300	
Capacity [kVA] ⁽¹⁾				9.1	12.2	17.5	22.9	28.2	33.5	43.8	
Output ratings	Fan or pump load	motor rating ⁽²⁾	HP	7.5	10	15	20	25	30	40	
			kW	5.5	7.5	11	15	18.5	22	30	
		Current [A] (110% overload)		110% 1Minute (Normal Duty)							
	General load	motor rating ⁽²⁾	HP	5.5	7.5	10	15	20	25	30	
			kW	3.7	5.5	7.5	11	15	18.5	22	
		Current [A] (150% overload)		150% 1 Minute (Heavy Duty)							
	Frequency				0.01 ~ 120 Hz						
	Voltage				200 ~ 230 V ⁽³⁾						
Input ratings	Voltage				3φ 200 ~ 230 V (-15% ~ +10 %)						
	Frequency				50/60 Hz (± 5 %)						
Protection degree				IP20 / UL Type1			IP00 / UL Open ⁽³⁾				
Weight [kg (lbs.)]				4.9(10.8)	6(13.2)	6(13.2)	13(28.7)	13.5(29.8)	20(44.1)	20(44.1)	

2.2 380~480V Class (5.5~30kW / 7.5~40HP)

Model Number (SVxxxIP5A-4)				055	075	110	150	185	220	300	
Capacity [kVA] ⁽¹⁾				9.6	12.7	19.1	23.9	31.1	35.9	48.6	
Output ratings	Fan or pump load	motor rating ⁽²⁾	HP	7.5	10	15	20	25	30	40	
			kW	5.5	7.5	11	15	18.5	22	30	
		Current [A] (110% overload)		110% 1Minute (Normal Duty)							
	General load	motor rating ⁽²⁾	HP	5.5	7.5	10	15	20	25	30	
			kW	3.7	5.5	7.5	11	15	18.5	22	
		Current [A]/Built-in DCL Type (150% overload)		150% 1 Minute (Heavy Duty)							
	Frequency				0.01 ~ 120 Hz						
	Voltage				380 ~ 480 V ⁽³⁾						
Input ratings	Voltage				3φ 380 ~ 480 V (-15% ~ +10 %)						
	Frequency				50/60 Hz (± 5 %)						
Protection degree				IP20 / UL Type1			IP00 / UL Open ⁽³⁾				
Weight [kg (lbs.)]	Standard Type			4.9(10.8)	6(13.2)	6(13.2)	12.5(27.6)	13(28.7)	20(44.1)	20(44.1)	
	Built-in DCL Type			-	-	-	19.5(42.9)	19.5(42.9)	26.5(58.3)	26.5(58.3)	

2.3 380 ~ 480V Class (37~90kW / 50~125HP)

Model Number (SVxxxIP5A-4)				370	450	550	750	900	
Capacity [kVA] ⁽¹⁾				59.8	72.5	87.6	121.1	145.8	
Output ratings	Fan or pump load	motor rating ⁽²⁾	HP	50	60	75	100	125	
			kW	37	45	55	75	90	
		Current [A] (110% overload)		75	91	110	152	183	110% 1 Minute (Normal Duty)
	General load	motor rating ⁽²⁾	HP	40	50	60	75	100	
			kW	30	37	45	55	75	
		Current [A] (150% overload)		150% 1 Minute (Heavy Duty)					
	Frequency				0.01 ~ 120 Hz				
Voltage				380 ~ 480 V ⁽³⁾					
Input ratings	Voltage			3φ 380 ~ 480 V (-15% ~ +10 %)					
	Frequency			50/60 Hz (± 5 %)					
Protection degree				IP00 / UL Open ⁽³⁾					
Weight [kg (lbs.)]	Standard Type			27(59.5)	27(59.5)	29(64)	42(92.6)	43(94.8)	
	Built-in DCL Type			39(86)	40(88.2)	42(92.6)	67(147.4)	68(149.9)	

2.4 380 ~ 480V Class (110~450kW / 150~600HP)

Model Number (SVxxxIP5A-4)				1100	1320	1600	2200	2800	3150	3750	4500	
Capacity [kVA] ⁽¹⁾				178	210	259	344	436	488	582	699	
Output ratings	Fan or pump load	motor rating ⁽²⁾	HP	150	200	250	300	350	400	500	600	
			kW	110	132	160	220	280	315	375	450	
		Current [A] (110% overload)		223	264	325	432	547	613	731	877	110% 1 Minute (Normal Duty)
	General load	motor rating ⁽²⁾	HP	125	150	200	250	300	350	400	500	
			kW	90	110	132	160	220	280	315	375	
		Current [A] (150% overload)		183	223	264	325	432	547	613	731	150% 1 Minute (Heavy Duty)
	Frequency				0.01 ~ 120 Hz							
Voltage				380 ~ 480 V ⁽³⁾								
Input ratings	Voltage			3φ 380 ~ 480 V (-15% ~ +10 %)								
	Frequency			50/60 Hz (± 5 %)								
Protection degree				IP00 / UL Open ⁽⁴⁾								
DCL (DC Choke)				Built-in				External Option				
Weight [kg (lbs.)]				101 (222.7)	101 (222.7)	114 (251.3)	200 (441.9)	200 (441.9)	243 (535.7)	380 (837.7)	380 (837.7)	

Common Specifications

Cooling method		Forced air cooling	
Short Circuit Rating		65kA, suitable for use on a circuit capable of delivering not more than 100,000 RMS Symmetrical amperes, 240 (or 480V) volts maximum	
Agency Approvals		UL and cUL listed, CE marked	
CONTROL	Control Method	V/F, Sensorless Vector, Slip Compensation, Easy Start Selectable	
	Frequency Setting Resolution	Digital Reference: 0.01 Hz (Below 100 Hz), 0.1 Hz (Over 100 Hz) Analog Reference: 0.01 Hz / 60 Hz	
	Frequency Accuracy	Digital: 0.01 % of Max. Output Frequency Analog: 0.1 % of Max. Output Frequency	
	V/F Ratio	Linear, Squared Pattern, User V/F	
	Overload Capacity	110 % per 1 min, 120% per 1 min ⁽⁵⁾	
	Torque Boost	Manual Torque Boost (0 ~ 15 % settable), Auto Torque Boost	
OPERATION	Operation Method	Keypad / Terminal / Communication Operation	
	Frequency Setting	Analog: 0 ~ 12V / -12V ~ 12V / 4 ~ 20mA or 0~20mA/ Pulse / Ext-PID Digital: Keypad	
	Input Signal	Start Signal	Forward, Reverse
		Multi-Step	Up to 18 Speeds can be set including Jog (Use Programmable Digital Input Terminal)
		Multi Step Accel/Decel Time	0.1~ 6,000 sec, Max 4 types can be set via Multi- Function Terminal. Accel/Decel Pattern: Linear, U-Curve, S-Curve Selectable
		Emergency Stop	Interrupts the Output of Inverter
		Jog	Jog Operation
Fault Reset		Trip Status is Reset when Protection Function is Active	
Output signal	Operating Status	Frequency Detection Level, Overload Alarm, Stalling, Over Voltage, Low Voltage, Inverter Overheating/ Running/ Stopping/ Constant running, Inverter By-Pass, Speed Searching	
	Fault Output	Contact Output (3A, 3C, 3B) – AC 250V 1A, DC 30V 1A	
	Indicator	Choose 2 from Output Frequency, Output Current, Output Voltage, DC Link Voltage (Output Voltage: 0 ~ 10V)	
Operation Function		DC Braking, Frequency Limit, Frequency Jump, 2 nd Function, Slip Compensation, Reverse Rotation Prevention, Auto Restart, Inverter By-Pass, Auto-Tuning, PID Control, Flying Start, Safety Stop, Flux Braking, Low leakage, Pre-PID, Dual-PID, MMC ⁽⁶⁾ , Easy Start, Pre-heater	
PROTECTION	Inverter Trip	Over Voltage, Low Voltage, Over Current, Ground Fault, Inverter Overheat, Motor Overheat, Output Phase Open, Overload Protection, External Fault 1, 2, Communication Error, Loss of Speed Command, Hardware Fault, Option Fault etc	
	Inverter Alarm	Stall Prevention, Overload Alarm, Thermal Sensor Fault	

Chapter 2 - Specification

DISPLAY	Keypad	Operation Information	Output Frequency, Output Current, Output Voltage, Frequency Set Value, Operating Speed, DC Voltage, Integrating Wattmeter, Fan ON time, Run-time, Last Trip Time
		Trip Information	Trips Indication when the Protection Function activates. Max. 5 Faults are saved. Last Trip Time.
ENVIRONMENT	Ambient Temperature	-10°C ~ 40°C (14°F ~ 104°F) (Use loads less than 80% at 50°C)	
	Storage Temperature	-20°C ~ 65°C (14°F ~ 149°F)	
	Ambient Humidity	Less Than 90 % RH Max. (Non-Condensing)	
	Altitude – Vibration	Below 1,000m (3,300ft), Below 5.9m/sec ² (0.6g)	
	Application Site	Pollution degree 2, No Corrosive Gas, Combustible Gas, Oil Mist, or Dust	

- (1) Rated capacity ($\sqrt{3} \times V \times I$) is based on 220V for 200V class and 460V for 400V class.
- (2) Indicates the maximum applicable capacity when using a 4-Pole standard motor.
- (3) IP20 or UL Enclosed Type1 can be provided by the option.
- (4) IP20 or UL Enclosed Type1 is not provided.
- (5) Overload rating 120%, 1 min is based on ambient 25°C.
- (6) MMC (Multi Motor Control) function is applied to the drives only for 5.5 ~ 90kW (7.5 ~125HP).

2.5 Dimensions

1) SV055iP5A (200/400V Class)

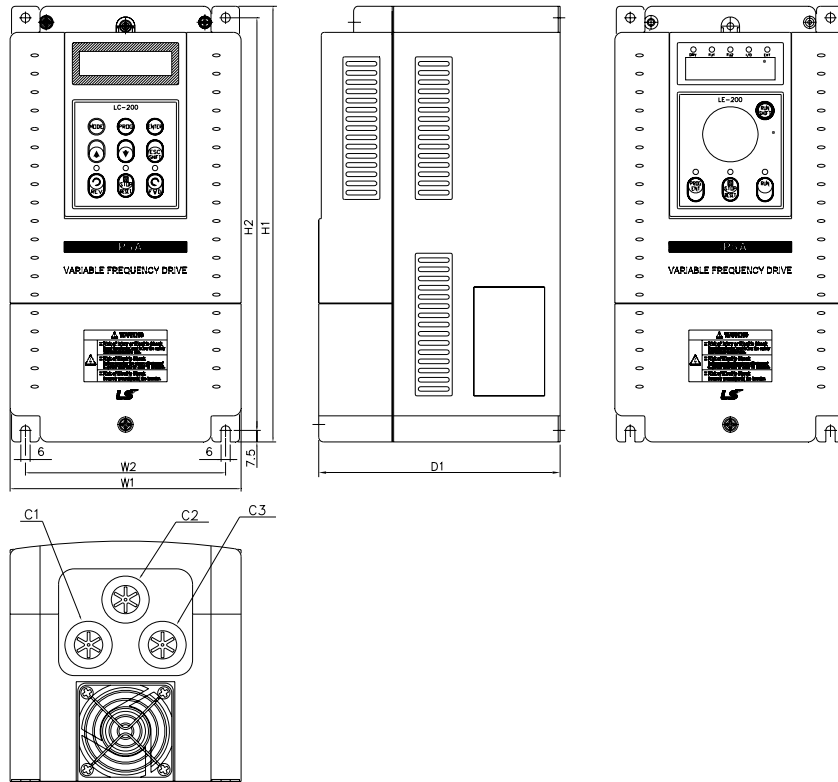

Model	W1	W2	H1	H2	D1	C1	C2	C3	mm (inches)
									Enclosure Type
SV055iP5A-2/4	150 (5.91)	130 (5.12)	284 (11.18)	269 (10.69)	156.5 (6.16)	24 (0.98)	24 (0.98)	24 (0.98)	IP20 UL Type 1

2) SV075~300iP5A (200/400V Class)

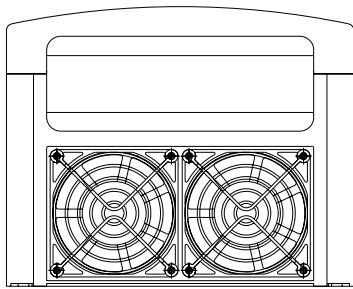
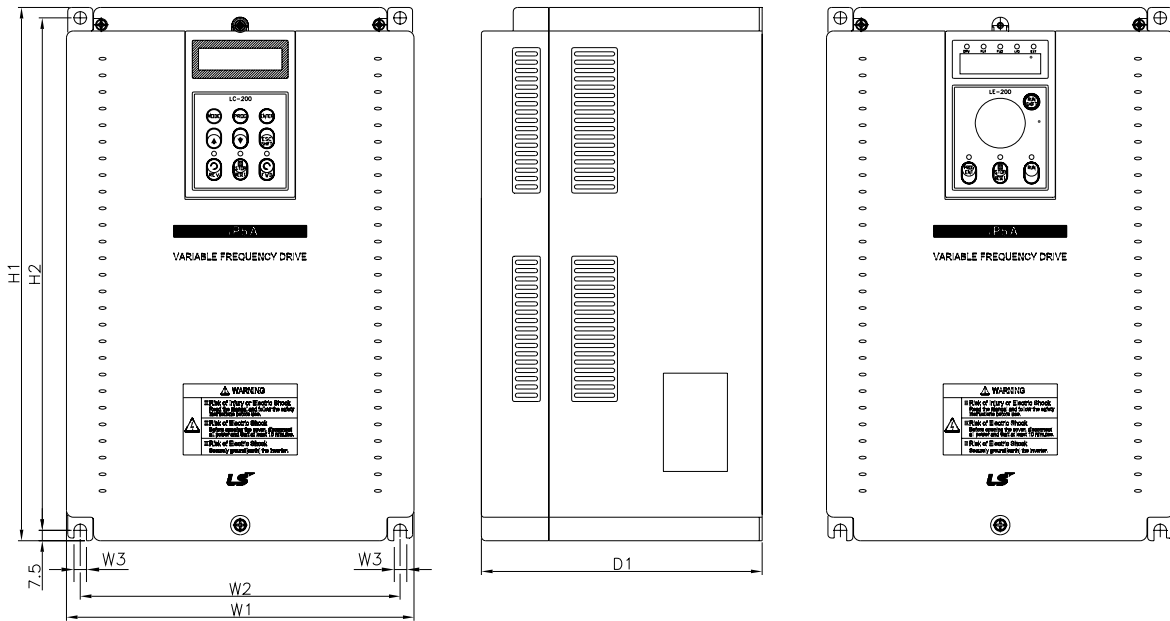

<SV150~300iP5A-2/4>

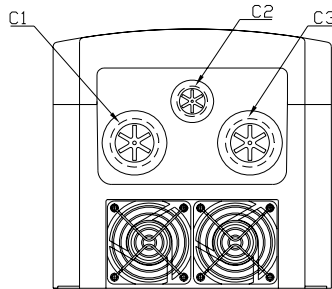

<SV075~110iP5A-2/4>

mm (inches)

Model	W1	W2	W3	H1	H2	D1	C1	C2	C3	Enclosure Type
SV075iP5A-2/4	200 (7.87)	180 (7.09)	6 (0.23)	284 (11.18)	269 (10.69)	182 (7.16)	35 (1.37)	24 (0.98)	35 (1.37)	IP20 UL Type 1
SV110iP5A-2/4	200 (7.87)	180 (7.09)	6 (0.23)	284 (11.18)	269 (10.69)	182 (7.16)	35 (1.37)	24 (0.98)	35 (1.37)	IP20 UL Type 1
SV150iP5A-2/4	250 (9.84)	230 (9.06)	9 (0.35)	385 (15.16)	370 (14.57)	201 (7.91)	-	-	-	IP00 UL Open
SV185iP5A-2/4	250 (9.84)	230 (9.06)	9 (0.35)	385 (15.16)	370 (14.57)	201 (7.91)	-	-	-	IP00 UL Open
SV220iP5A-2/4	304 (11.97)	284 (11.18)	9 (0.35)	460 (18.11)	445 (17.52)	234 (9.21)	-	-	-	IP00 UL Open
SV300iP5A-2/4	304 (11.97)	284 (11.18)	9 (0.35)	460 (18.11)	445 (17.52)	234 (9.21)	-	-	-	IP00 UL Open

3) SV150~300iP5A (UL Type 1 or UL Open Type with Conduit Option used, 200V/400V Class)

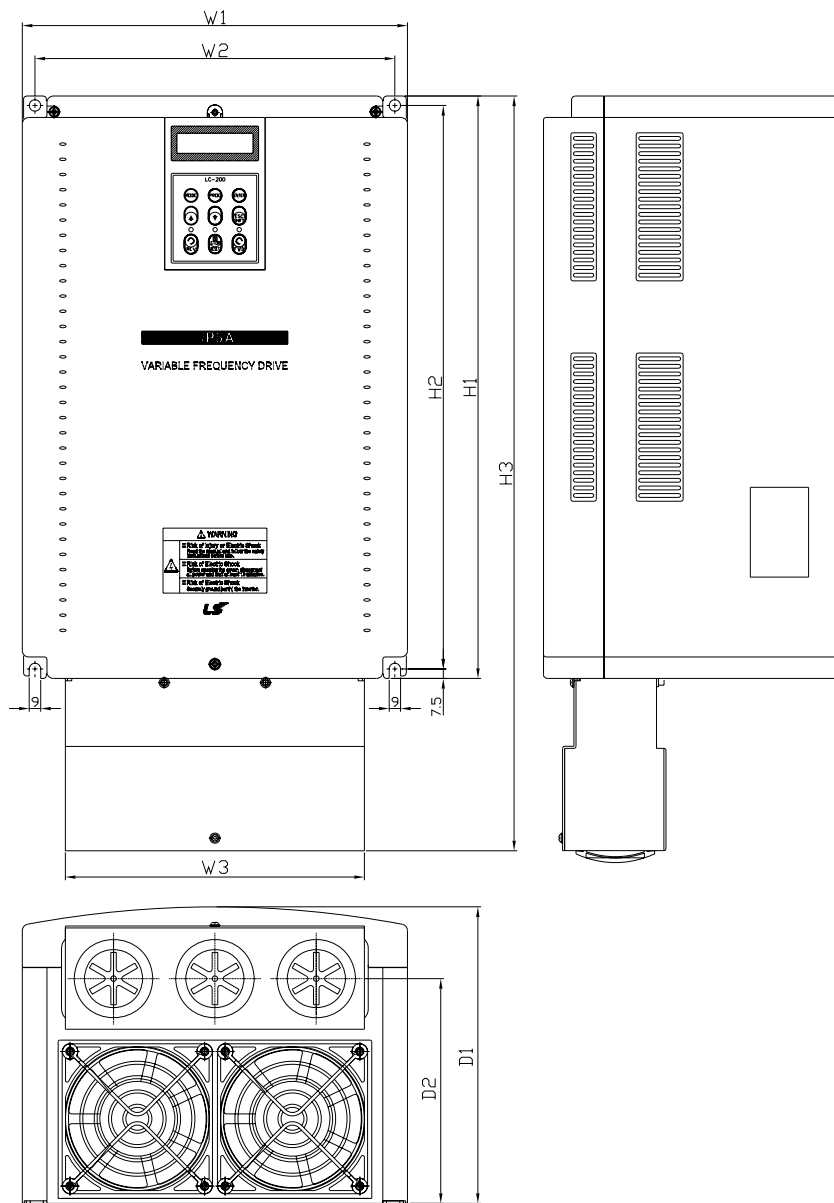

mm (inches)

Model	W1	W2	W3	H1	H2	H3	D1	D2	Enclosure Type
SV150iP5A-2/4	250 (9.84)	230 (9.06)	200.8 (7.9)	385 (15.16)	370 (14.57)	454.2 (17.88)	201 (7.91)	146 (5.74)	IP20 UL Type 1
SV185iP5A-2/4	250 (9.84)	230 (9.06)	200.8 (7.9)	385 (15.16)	370 (14.57)	454.2 (17.88)	201 (7.91)	146 (5.74)	IP20 UL Type 1
SV220iP5A-2/4	304 (11.97)	284 (11.18)	236 (9.29)	460 (18.11)	445 (17.52)	599.2 (23.59)	234 (9.21)	177.5 (6.98)	IP20 UL Type 1
SV300iP5A-2/4	304 (11.97)	284 (11.18)	236 (9.29)	460 (18.11)	445 (17.52)	599.2 (23.59)	234 (9.21)	177.5 (6.98)	IP20 UL Type 1

Note) Mounting NEMA 1 conduit option to the 15~90Kw(20~125HP) Open Type meets NEMA 1 but does not comply with UL Enclosed Type 1. To that end, please purchase UL Type 1 product.

4) SV150 ~ SV300 iP5A (400V Class) – Built-in DCL Type

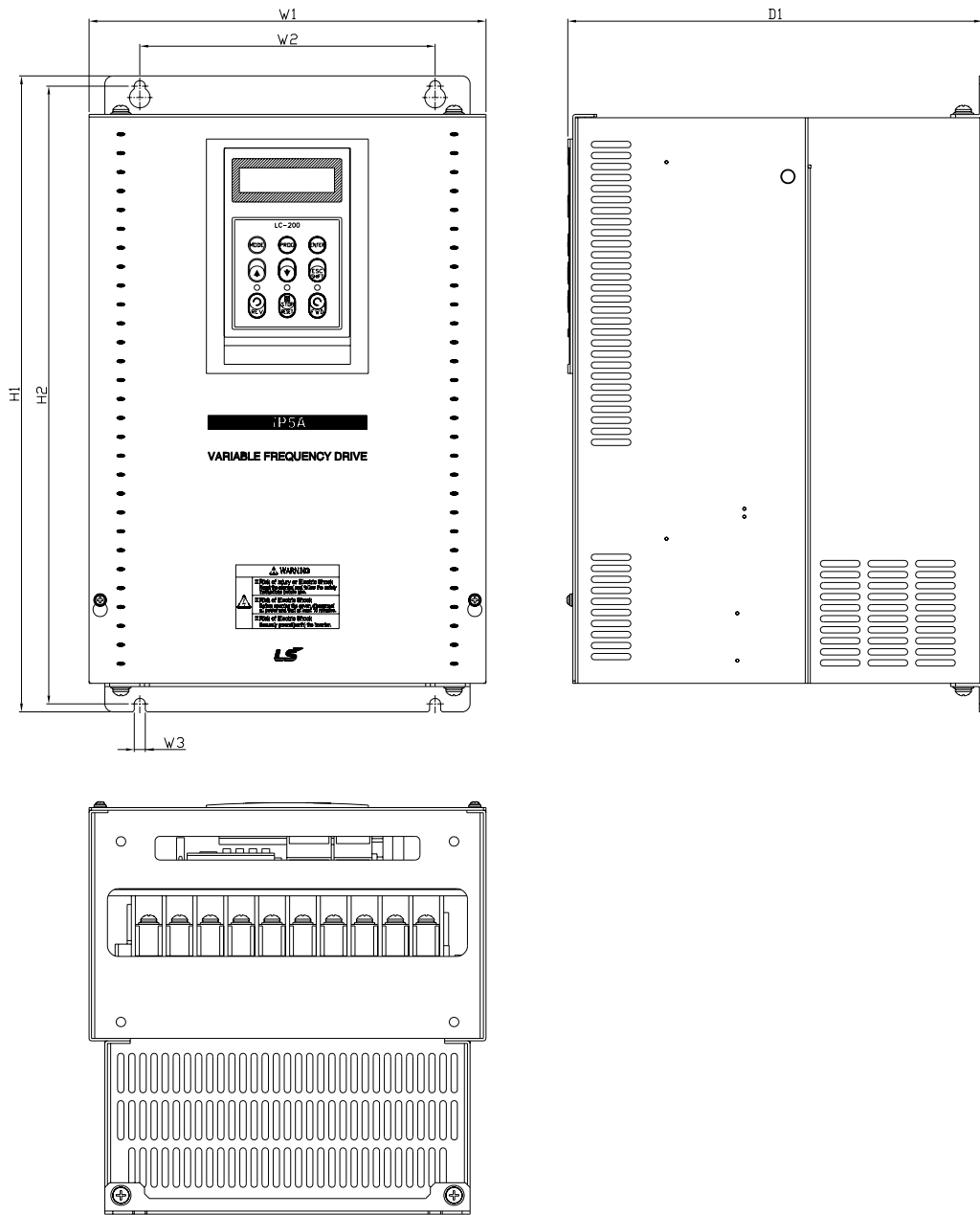

mm (inches)

Model	W1	W2	W3	H1	H2	D1	Enclosure Type
SV150, 185iP5A-4L (Built-in DCL Type)	250 (9.84)	186 (7.32)	7 (0.28)	403.5 (15.88)	392 (15.43)	261.2 (10.28)	IP00 UL Type 1
SV220, 300iP5A-4L (Built-in DCL Type)	260 (10.23)	220 (8.66)	7 (0.28)	480 (18.89)	468.5 (18.44)	268.6 (10.57)	IP20 UL Type 1

5) SV150 ~ SV300 iP5A (Built-in DCL Type, UL Type 1 or UL Open Type with Conduit Option used, 400V Class)

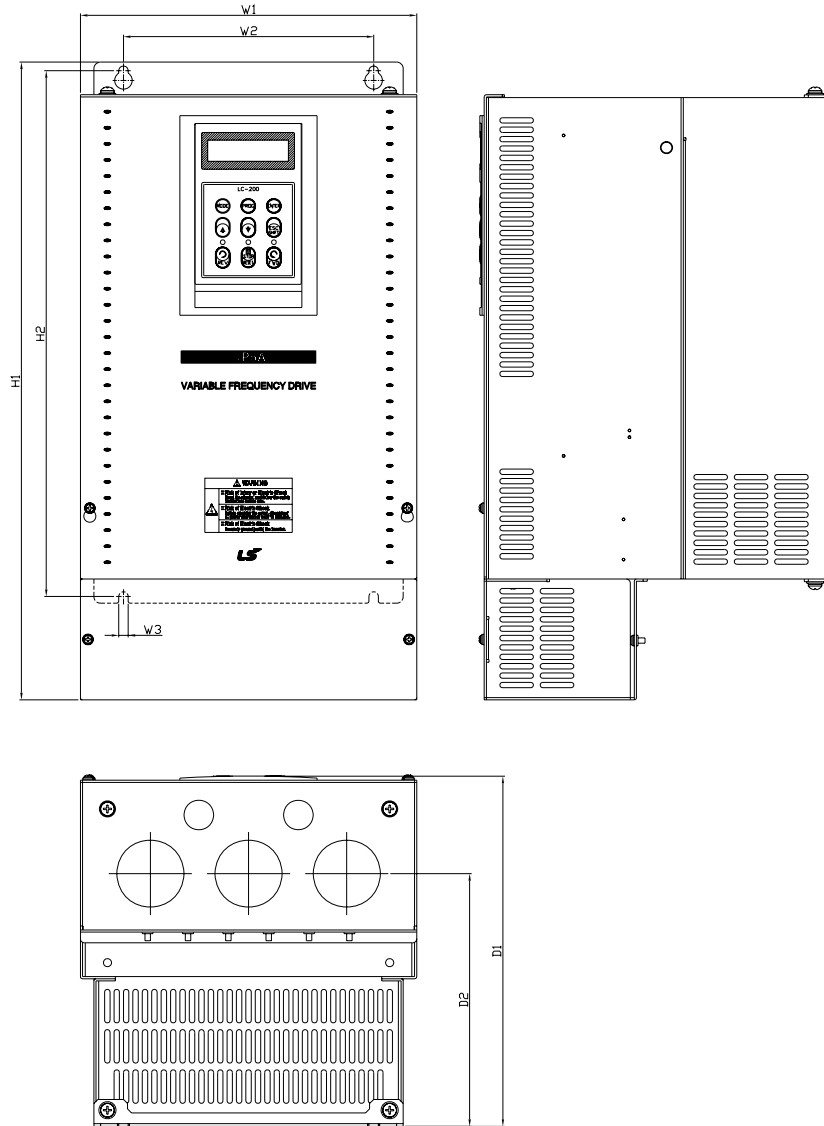

Model	W1	W2	W3	H1	H2	mm (inches)		Enclosure Type
						D1	D2	
SV150, 185iP5A-4L (Built-in DCL Type)	250 (9.84)	186 (7.32)	7 (0.28)	475.5 (18.72)	392 (15.43)	261.2 (10.28)	188.4 (7.42)	IP20 UL Type 1
SV220, 300iP5A-4L (Built-in DCL Type)	260 (10.23)	220 (8.66)	7 (0.28)	552 (21.73)	468.5 (18.44)	268.6 (10.57)	188.8 (7.43)	IP20 UL Type 1

6) SV370 ~ SV550iP5A (400V Class)

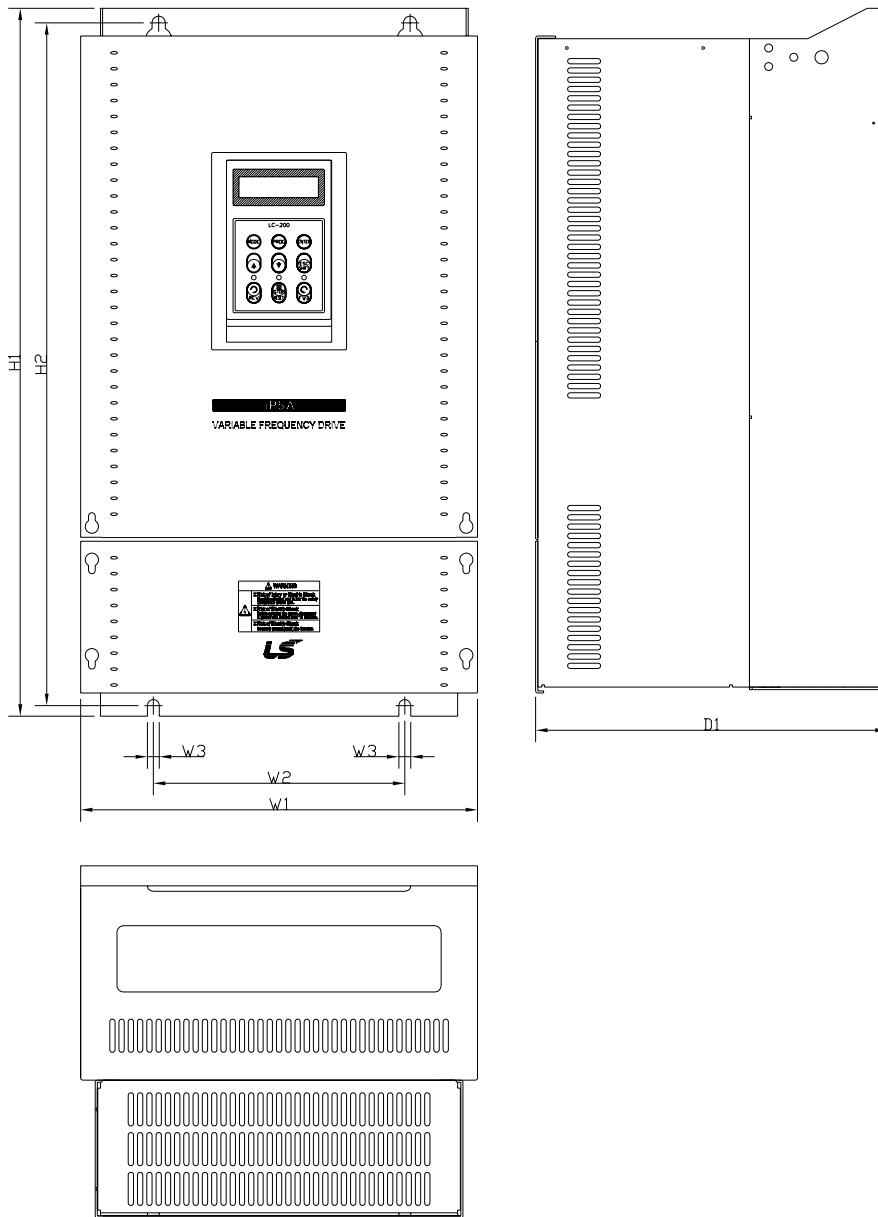

mm (inches)

Model	W1	W2	W3	H1	H2	D1	Enclosure Type
SV370, 450iP5A-4	300 (11.81)	190 (7.48)	9 (0.35)	534 (21.02)	515 (20.28)	265.6 (10.46)	IP00 UL Open
SV550iP5A-4	300 (11.81)	190 (7.48)	9 (0.35)	534 (21.02)	515 (20.28)	292.6 (11.52)	IP00 UL Open
SV370, 450iP5A-4L (Built-in DCL Type)	300 (11.81)	190 (7.48)	9 (0.35)	684 (26.92)	665 (26.18)	265.6 (10.46)	IP00 UL Open
SV550iP5A-4L (Built-in DCL Type)	300 (11.81)	190 (7.48)	9 (0.35)	684 (26.92)	665 (26.18)	292.6 (11.52)	IP00 UL Open

7) SV370~550iP5A (UL Type 1 or UL Open Type with Conduit Option Used, 400V Class)

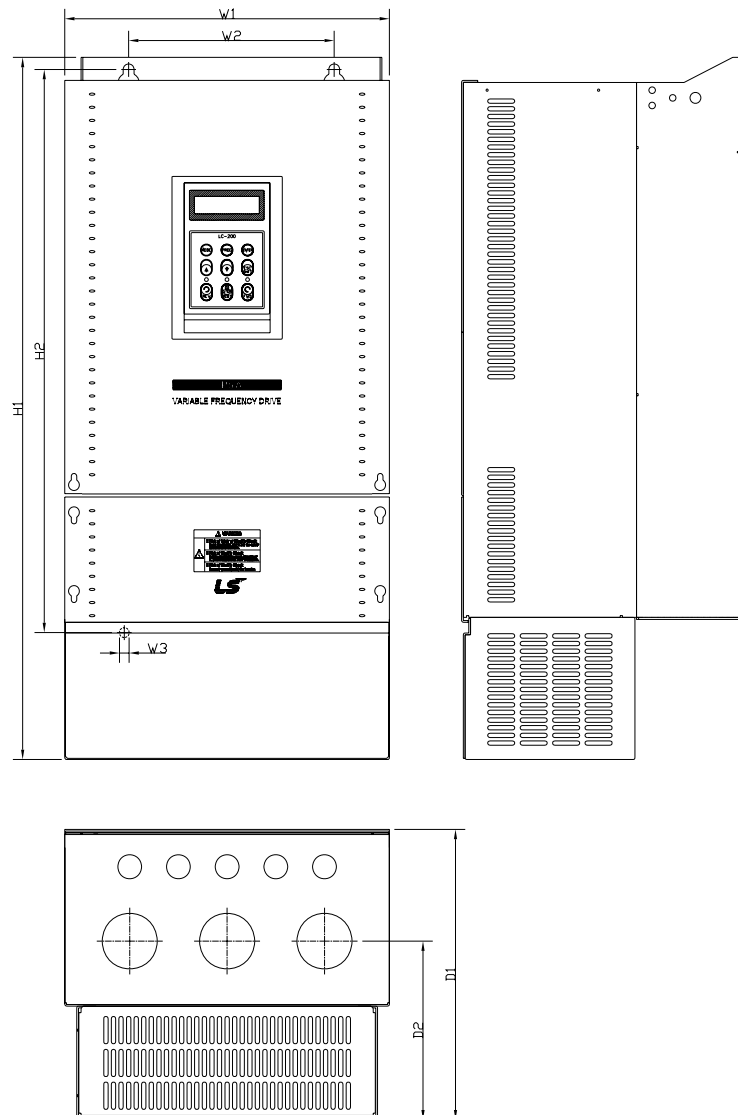

Model	W1	W2	W3	H1	H2	mm (inches)		Enclosure Type
						D1	D2	
SV370, 450iP5A-4	300 (11.81)	190 (7.48)	9 (0.35)	642 (25.28)	515 (20.28)	265.6 (10.46)	163.4 (6.43)	IP20 UL Type 1
SV550iP5A-4	300 (11.81)	190 (7.48)	9 (0.35)	642 (25.28)	515 (20.28)	292.6 (11.52)	190.4 (7.5)	IP20 UL Type 1
SV370, 450iP5A-4L (Built-in DCL Type)	300 (11.81)	190 (7.48)	9 (0.35)	792 (31.18)	665 (26.18)	265.6 (10.46)	163.4 (6.43)	IP20 UL Type 1
SV550iP5A-4L (Built-in DCL Type)	300 (11.81)	190 (7.48)	9 (0.35)	792 (31.18)	665 (26.18)	292.6 (11.52)	190.4 (7.5)	IP20 UL Type 1

Note) Mounting NEMA 1 conduit option to the 15~90Kw(20~125HP) Open Type meets NEMA 1 but does not comply with UL Enclosed Type 1. To that end, please purchase UL Type 1 product.

8) SV750, 900iP5A (400V Class)

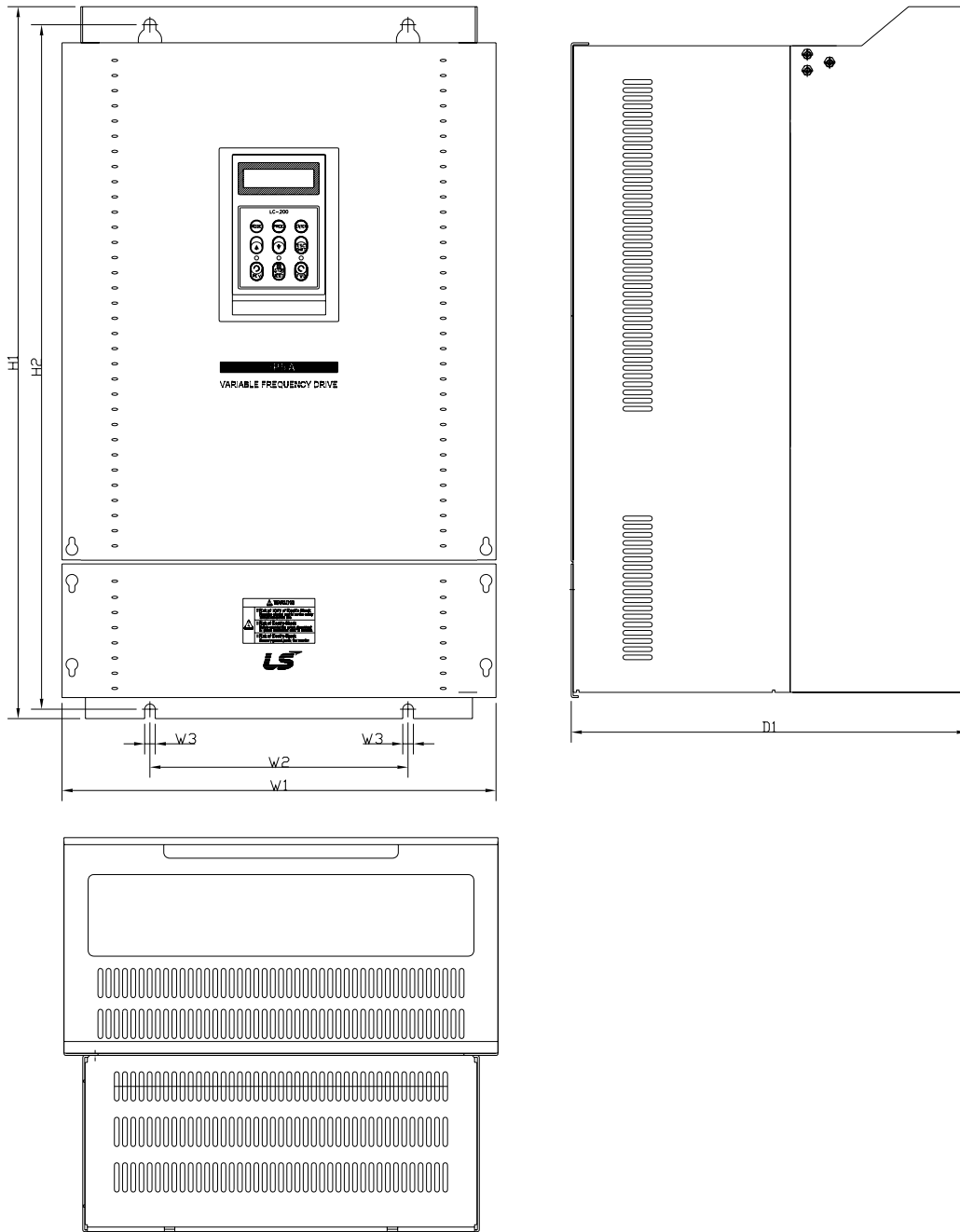

mm (inches)

Model	W1	W2	W3	H1	H2	D1	Enclosure Type
SV750, 900iP5A-4	370 (14.57)	220 (8.66)	9 (0.35)	610 (24.02)	586.5 (23.09)	337.6 (13.29)	IP00 UL Open
SV750, 900iP5A-4L (Built-in DCL Type)	370 (14.57)	220 (8.66)	9 (0.35)	760 (29.92)	736.6 (28.99)	337.6 (13.29)	IP00 UL Open

9) SV750, 900iP5A (UL Type 1 or UL Open Type with Conduit Option used, 400V Class)

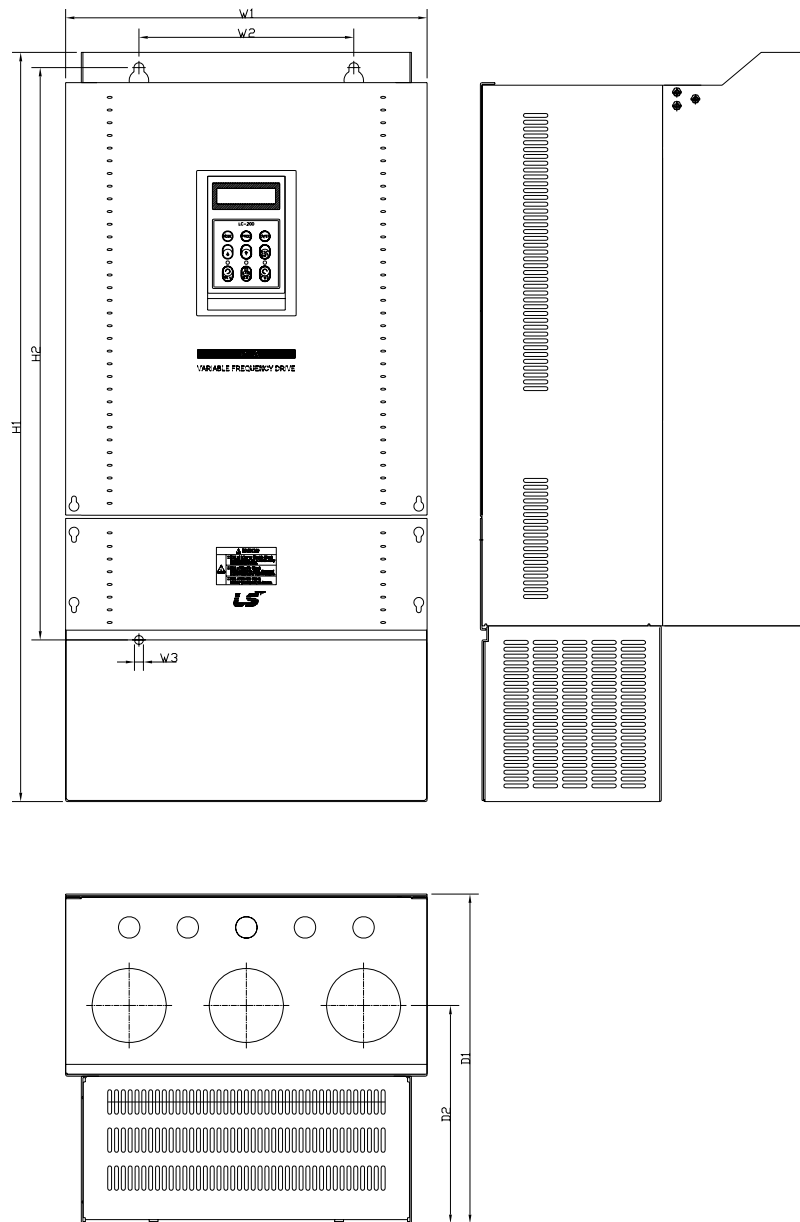

Model	W1	W2	W3	H1	H2	D1	D2	mm (inches)	
								Enclosure Type	
SV750,900iP5A-4	370 (14.57)	220 (8.66)	9 (0.35)	767.5 (30.22)	586.5 (23.09)	337.6 (13.29)	223.4 (8.8)	IP20	UL Type 1
SV750, 900iP5A-4L (Built-in DCL Type)	370 (14.57)	220 (8.66)	9 (0.35)	917.5 (36.12)	736.5 (28.99)	337.6 (13.29)	223.4 (8.8)	IP20	UL Type 1

Note) Mounting NEMA 1 conduit option to the 15~90Kw(20~125HP) Open Type meets NEMA 1 but does not comply with UL Enclosed Type 1. To that end, please purchase UL Type 1 product.

10) SV1100, 1600iP5A (400V Class)

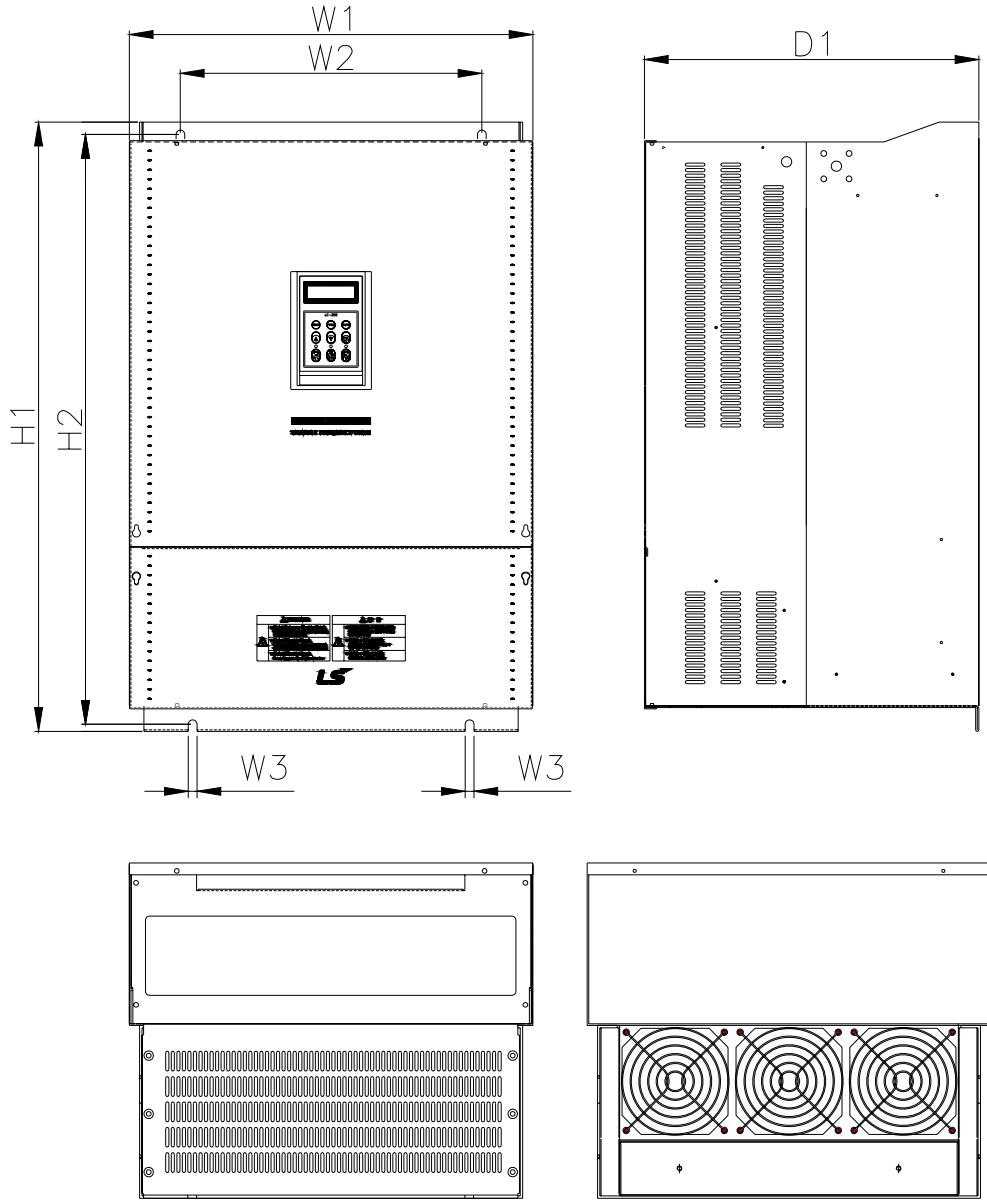

Model	W1	W2	W3	H1	H2	D1	mm(inches)
							Enclosure Type
SV1100,1320iP5A-4L	510 (20.08)	381 (15.00)	11 (0.43)	768.5 (30.26)	744 (29.29)	422.6 (16.64)	IP00 UL Open
SV1600iP5A-4L	510 (20.08)	381 (15.00)	11 (0.43)	844 (33.23)	819.5 (32.26)	422.6 (16.64)	IP00 UL Open

11) SV2200, 2800iP5A (400V Class)

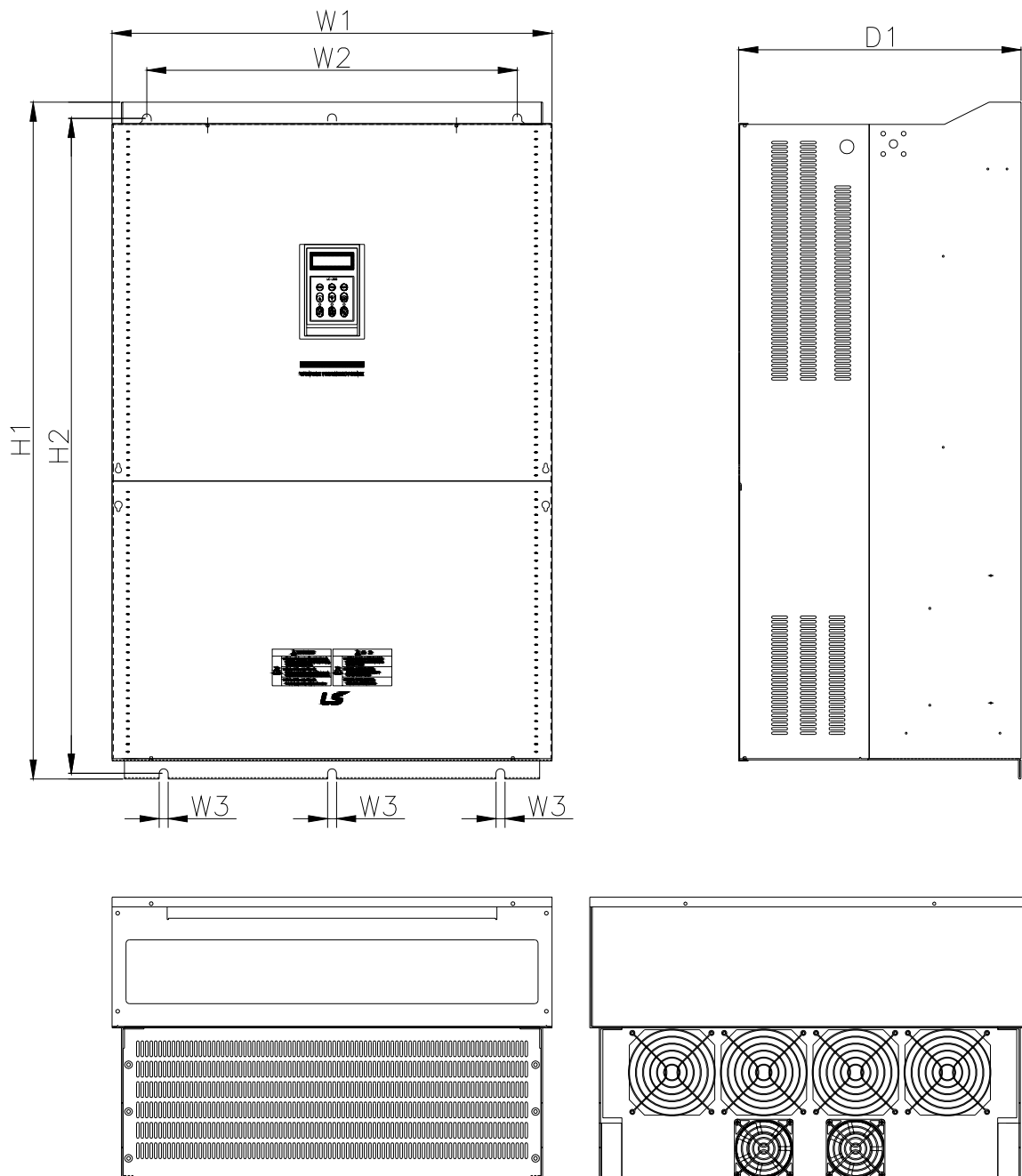

Model	W1	W2	W3	H1	H2	D1	mm(inches)
							Enclosure Type
SV2200, 2800iP5A-4L	690 (27.17)	581 (22.87)	14 (0.55)	1063 (41.85)	1028 (40.49)	449.6 (17.70)	IP00 UL Open

12) SV3150, 4500iP5A (400V Class)

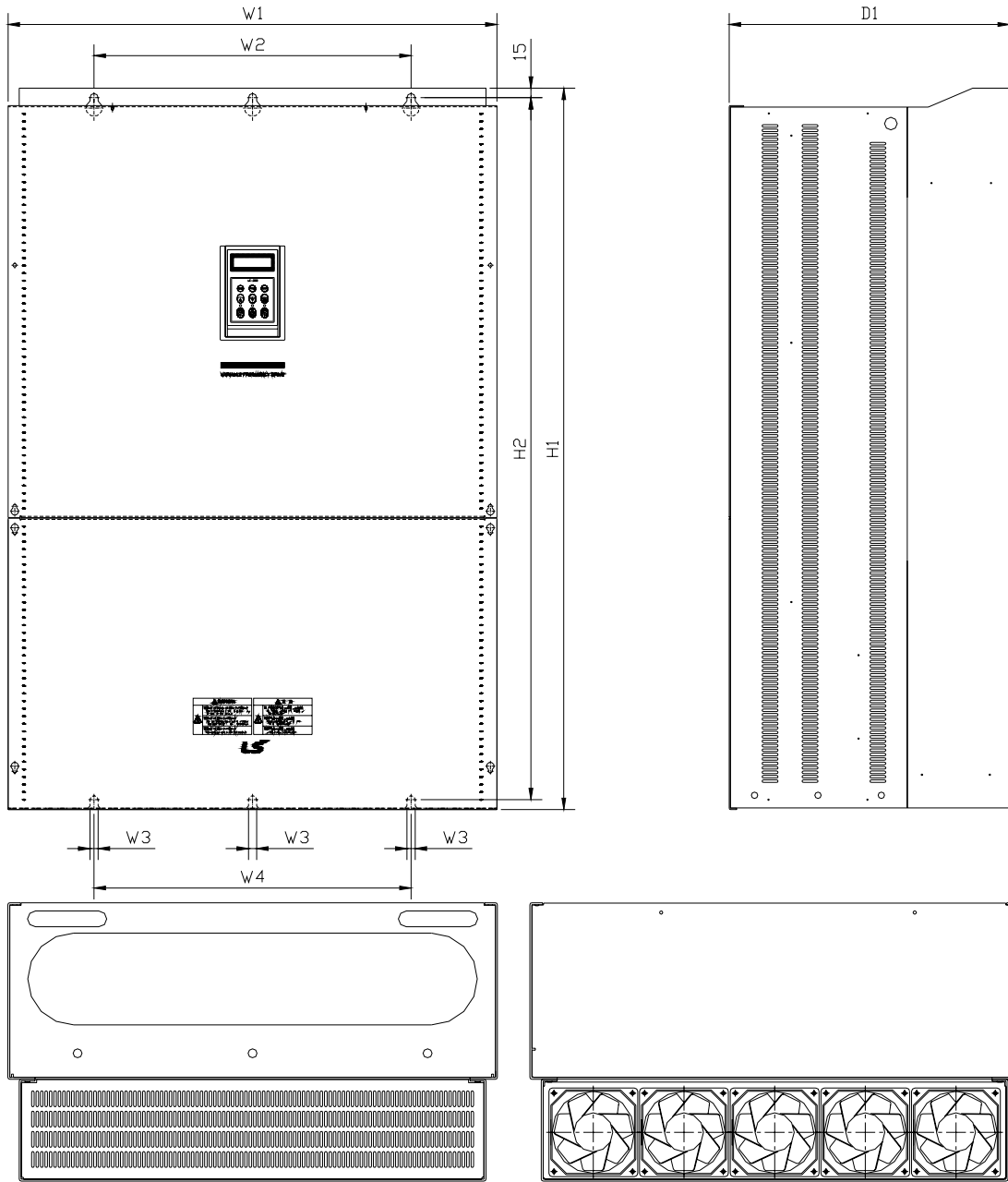

Model	W1	W2	W3	W4	H1	H2	D1	mm(inches)
								Enclosure Type
SV3150iP5A-4	772 (30.39)	500 (19.69)	13 (0.51)	500 (19.69)	1140.5 (44.90)	1110 (43.70)	442 (17.40)	IP00 UL Open
SV3750,4500iP5A-4	922 (36.30)	580 (22.83)	14 (0.55)	580 (22.83)	1302.5 (51.28)	1271.5 (50.06)	495 (19.49)	IP00 UL Open

CHAPTER 3 - INSTALLATION

3.1 Installation precautions

- 1) Handle the inverter with care to prevent damage to the plastic components. Do not hold the inverter by the front cover.
- 2) Do not mount the inverter in a location where excessive vibration (5.9 m/sec^2 or less) is present such as installing the inverter on a press or other moving equipment.
- 3) Install in a location where temperature is within the permissible range ($-10\sim 40^\circ\text{C}$).

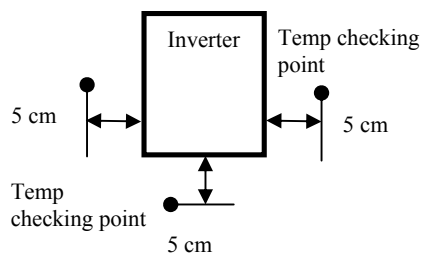

- 4) The inverter will be very hot during operation. Install it on a non-combustible surface.
- 5) Mount the inverter on a flat, vertical and level surface. Inverter orientation must be vertical (top up) for proper heat dissipation. Also leave sufficient clearances around the inverter. However, A= Over 500mm and B= 200mm should be obtained for inverters rated 30kW and above.

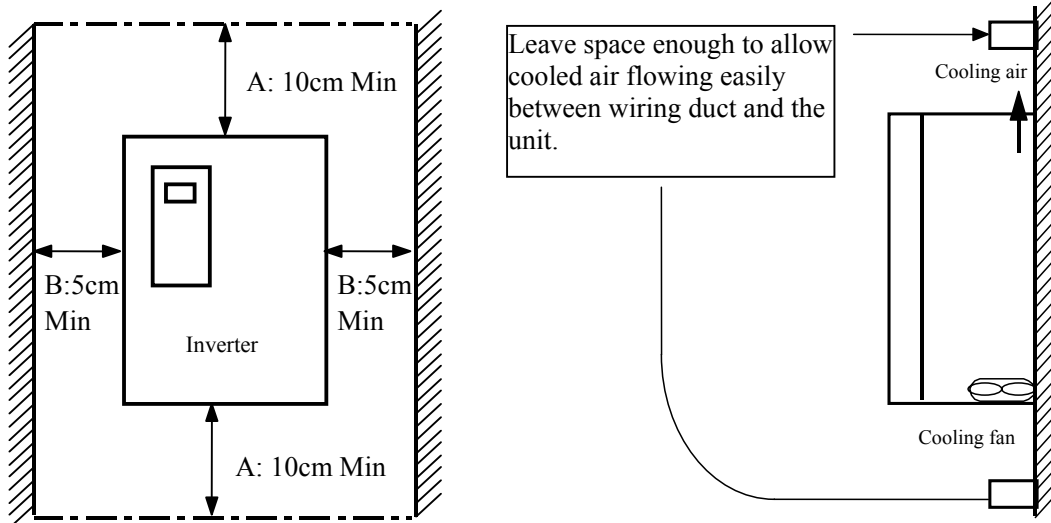

Chapter 3 - Installation

6) Do not mount the inverter in direct sunlight or near other heat sources.

7) The inverter shall be mounted in a Pollution Degree 2 environment. If the inverter is going to be installed in an environment with a high probability of dust, metallic particles, mists, corrosive gases, or other contaminants, the inverter must be located inside the appropriate electrical enclosure of the proper NEMA or IP rating.

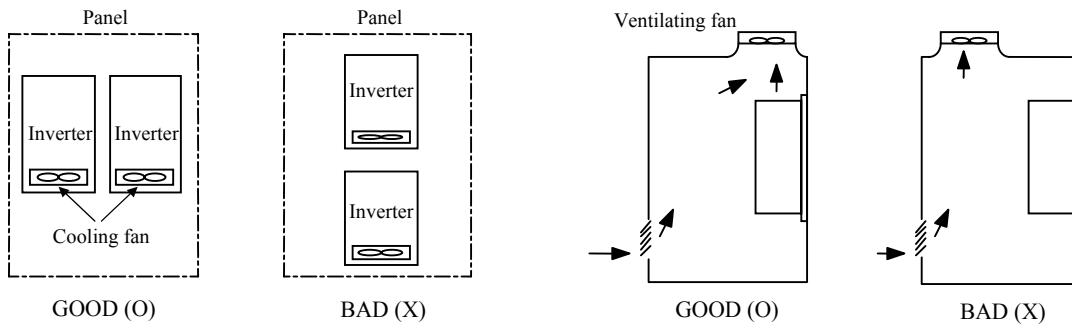

8) When two or more inverters are installed or a ventilation fan is mounted in inverter panel, the inverters and ventilation fan must be installed in proper positions with extreme care taken to keep the ambient temperature of the inverters below the permissible value. If they are installed in improper positions, the ambient temperature of the inverters will rise.



[When installing several inverters in a panel]

[When installing a ventilating fan in a panel]

9) Install the inverter using screws or bolts to insure the inverter is firmly fastened.

 CAUTION	
	<p>■ Risk of Electric Shock More than one disconnect switch may be required to de-energize the equipment before servicing.</p>

3.2 Wiring

3.2.1 Basic wiring

1) For 5.5~30kW (7.5~40HP)

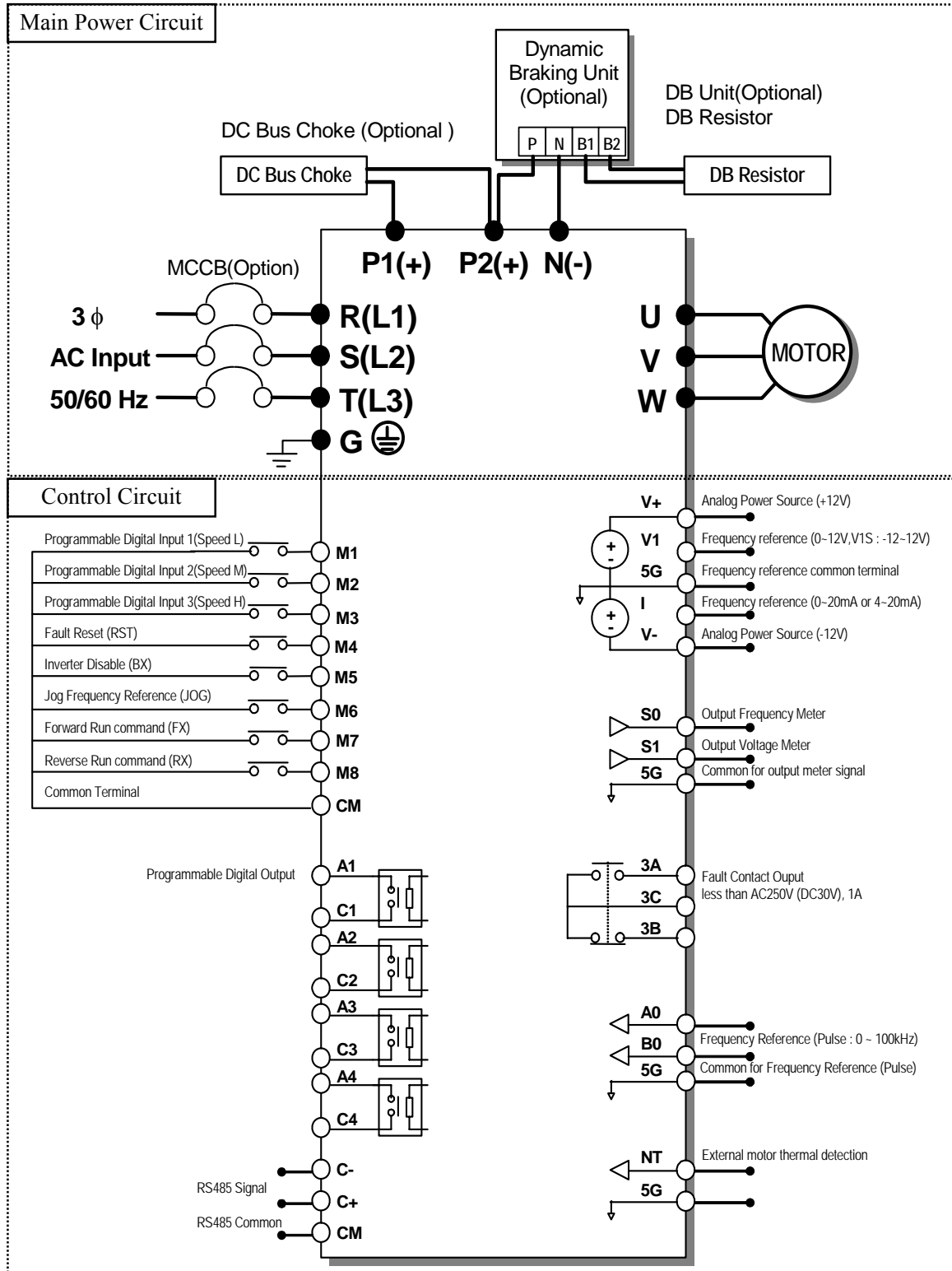

Note : 1) 5G is Common Ground for Analog Input/Output.
2) Use terminal V1 for V1, V1S (0~12V, -12 ~ 12V) input.

Chapter 3 - Installation

2) For 37~90kW (50~125HP) / 315~450(400~600HP)

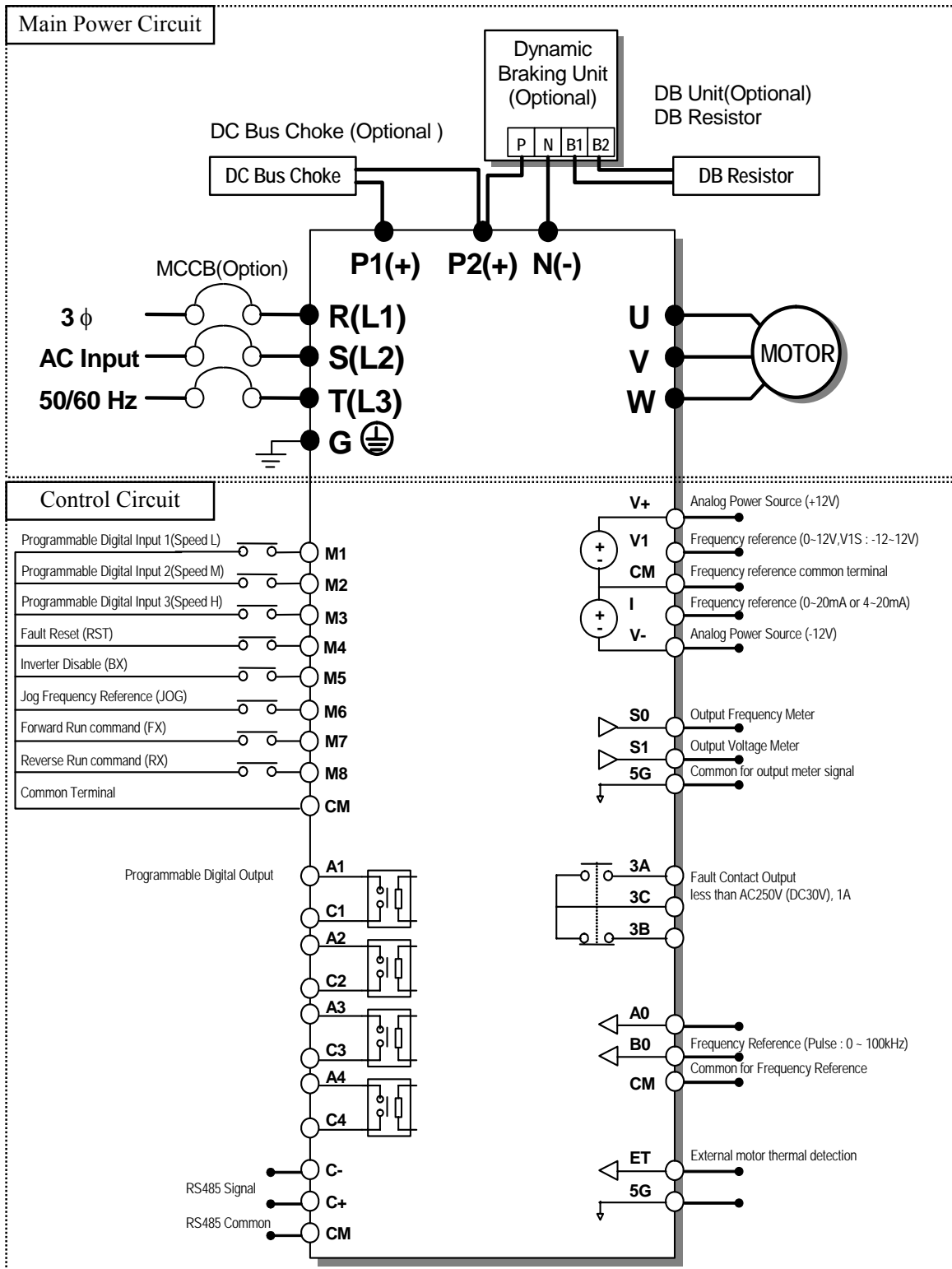

Note : 1) 5G is Common Ground for Analog Meter Output(S0,S1) and External motor thermal detection(ET).
 2) Use terminal V1 for V1, V1S (0~12V, -12 ~ 12V) input.

3) For 110~280kW (150~350HP)

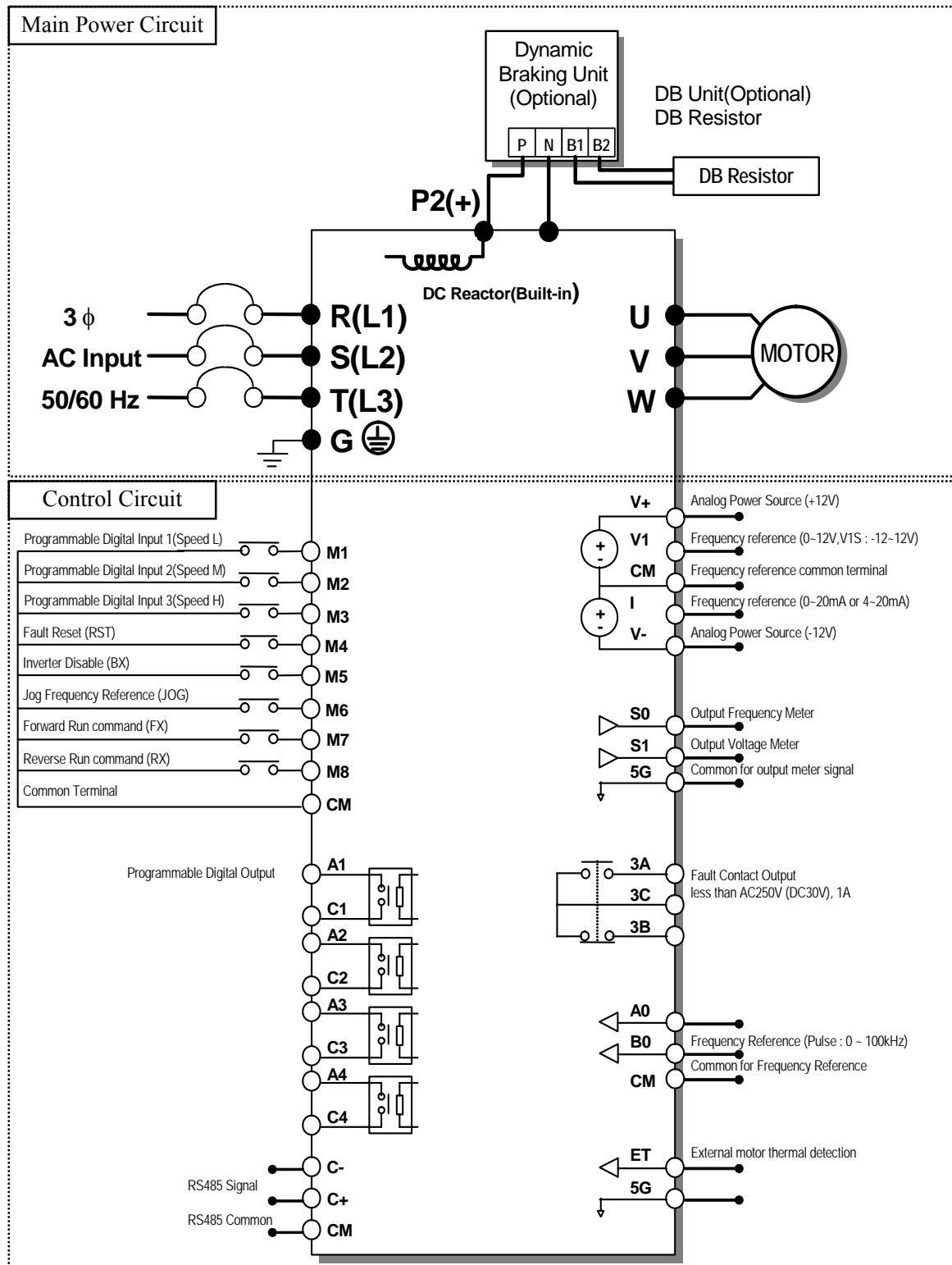

- Note :
- 1) 5G is Common Ground for Analog Meter Output(S0,S1) and External motor thermal detection(ET).
 - 2) Use terminal V1 for V1, V1S (0~12V, -12 ~ 12V) input.
 - 3) DC Reactor is built basically in the inverters for 110~280kW(150~350HP).

4) For 15~30kW (20~40HP) Built-in DCL Type

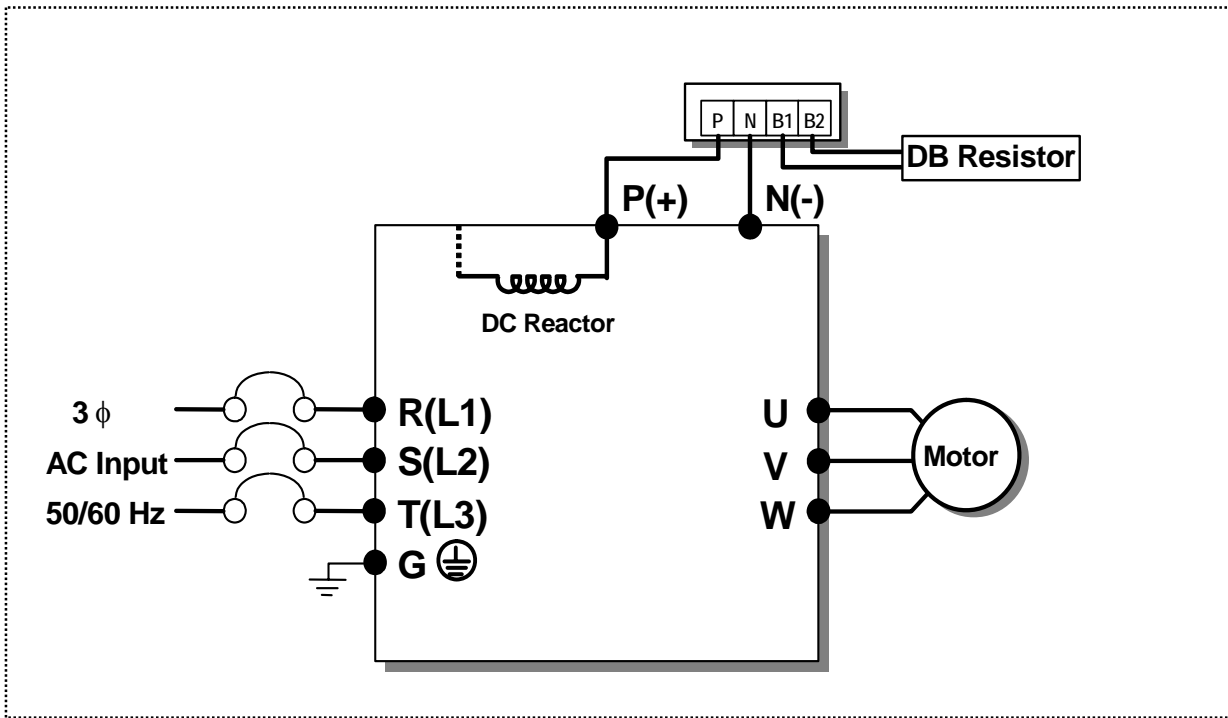

5) For 37~90kW (50~125HP) Built-in DCL Type

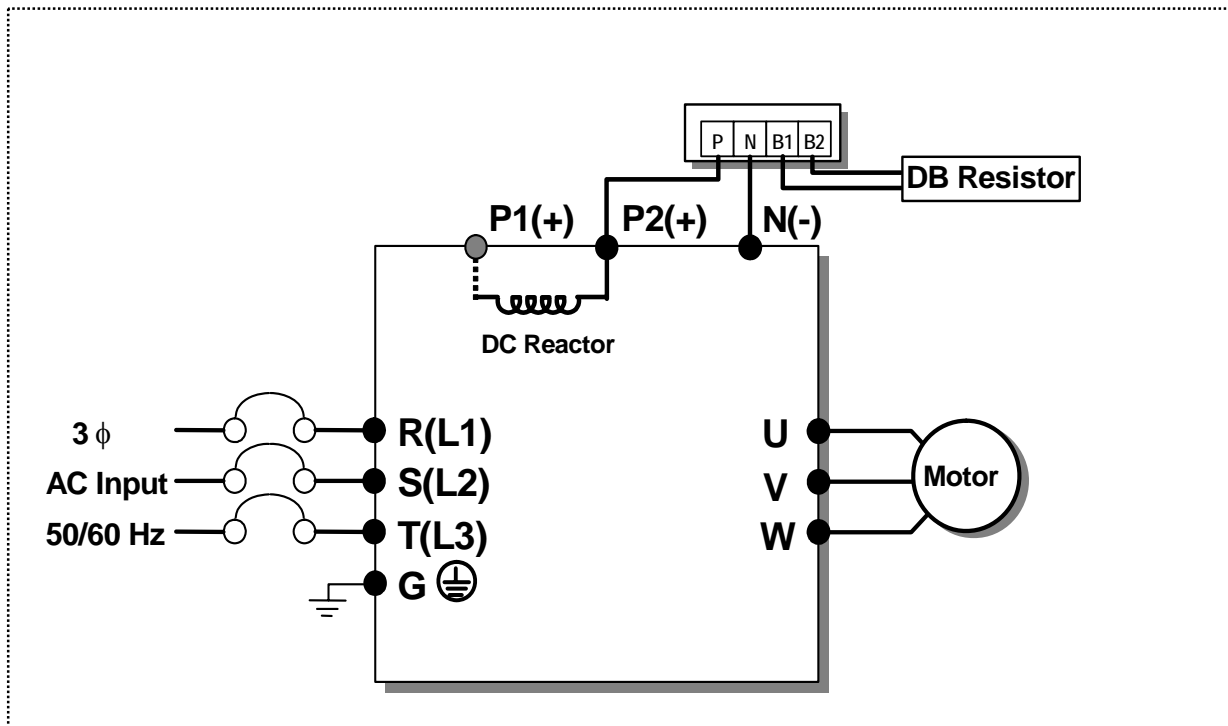

Note : P1(+) is not provided for wiring.

6) Power Terminals:

(1) 5.5 ~ 30 kW (200V/400V Class)

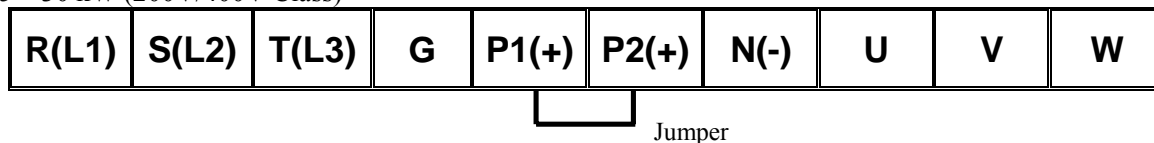

(2) 37~90kW (50~125HP) / 315~450kW (400~600HP) <400V Class>

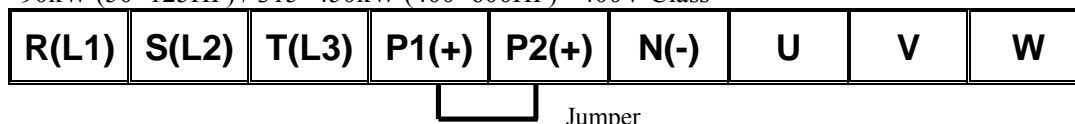

(3) 15~18.5kW (20~25HP) <Built-in DC Reactor Type, 400V Class>

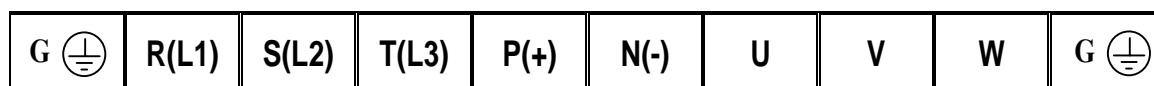

(4) 22~30kW (30~40HP) <Built-in DC Reactor Type, 400V Class>

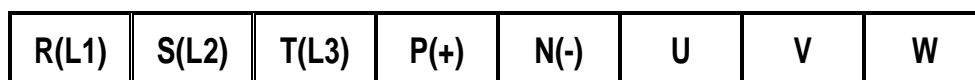

(5) 37~90kW (50~125HP) / 110 ~280kW (150~350HP) <Built-in DC Reactor Type, 400V Class>

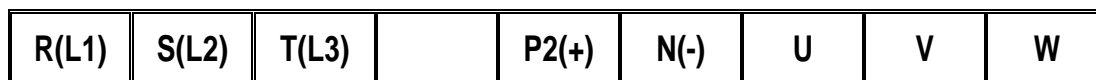

 Note : P1(+) is not provided for wiring.

Symbol	Description
R(L1), S(L2), T(L3)	AC Line Voltage Input
G	Earth Ground
P1(+), P2(+)	External DC Reactor (P1(+)-P2(+)) Connection Terminals (Jumper must be removed).
P2(+), N(-) or P(+), N(-)	DB Unit (P2(+)-N(-)) Connection Terminals
U, V, W	3 Phase Power Output Terminals to Motor

7) Control circuit terminal

5.5 ~ 30kW/7.5~40HP (200V/400V Class)

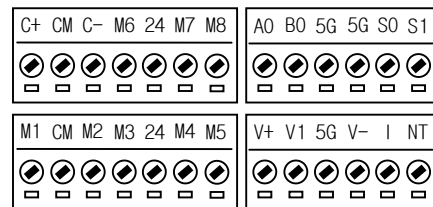
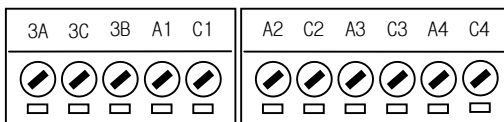
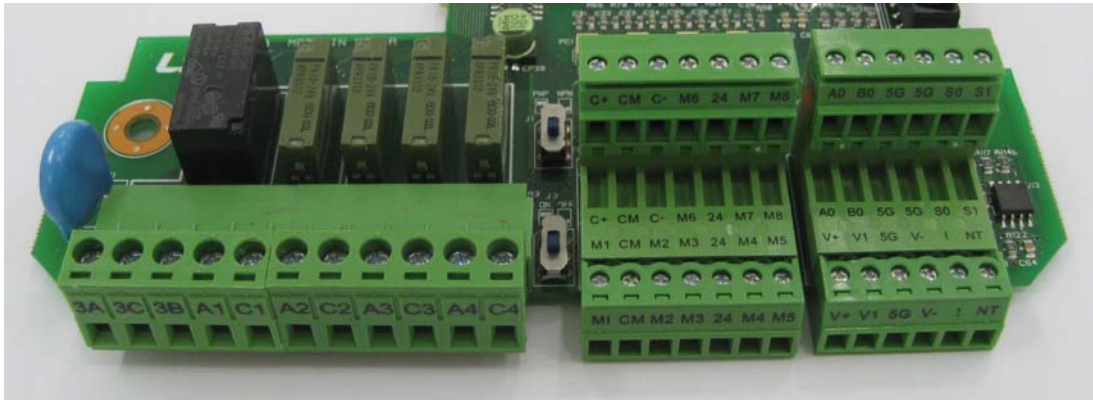

37 ~ 450 kW/ 50~600HP (400V Class)

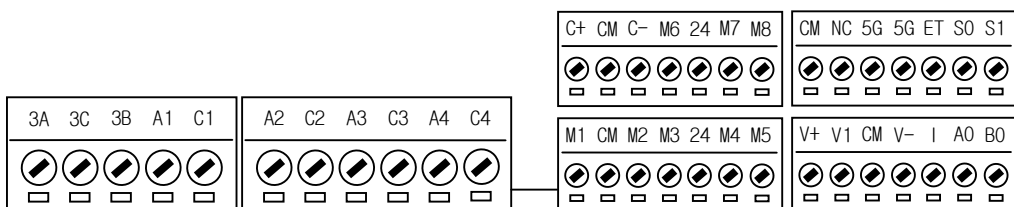
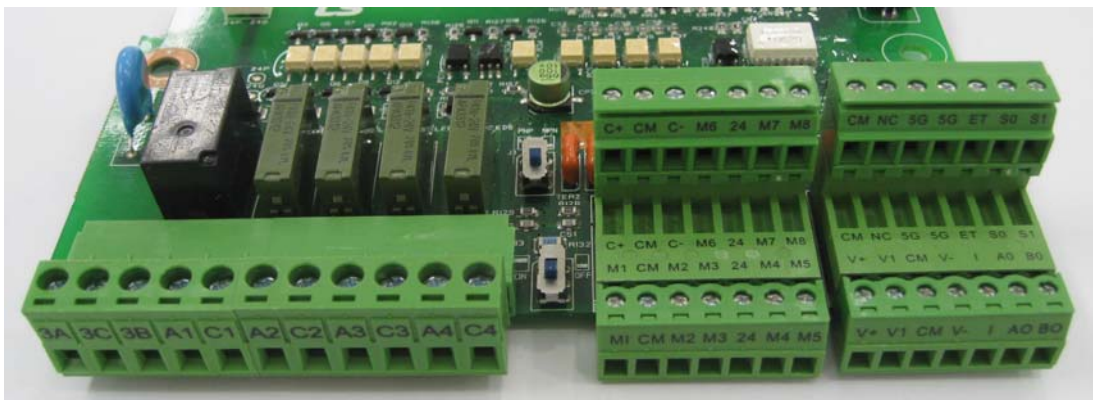

Type	Symbol	Name	Description
Input signal	Starting Contact Function Select	M1, M2, M3	Programmable Digital Input 1, 2, 3 Defines Programmable Digital Inputs. (Factory setting: Multi-Step Frequency 1, 2, 3)
		FX [M7]	Forward Run Command Forward Run When Closed and Stopped When Open.
		RX [M8]	Reverse Run Command Reverse Run When Closed and Stopped When Open.
		JOG [M6]	Jog Frequency Reference Runs at Jog Frequency when the Jog Signal is ON. The Direction is set by the FX (or RX) Signal.
		BX [M5]	Inverter Disable When the BX Signal is ON the Output of the Inverter is Turned Off. When Motor uses an Electrical Brake to Stop, BX is used to Turn Off the Output Signal. Take caution when BX Signal is OFF (Not Turned Off by Latching) and FX Signal (or RX Signal) is ON. If so, motor continues to Run.
		RST [M4]	Fault Reset Used for Fault Reset.
		CM	Sequence Common (NPN) / 24V Com. Common terminal for NPN contact input and also common for the external 24V supply.
		24	Sequence Common (PNP) / Ext. +24Vdc supply Common 24V terminal for PNP contact input. Can also be used as a 24Vdc external power supply (maximum output : +24V, 50mA)
	Analog frequency setting	V+, V-	Analog Power Source (+12V,-12V) Power supply for Analog Frequency Setting. Maximum Output: +12V, 100mA, -12V, 100mA.
		V1	Frequency Reference (Voltage) Used by a DC 0-12V or -12~ 12 V input to set the frequency reference. (Input impedance is 20 kΩ)
		I	Frequency Reference (Current) Used by a 0-20mA input to set the frequency reference. (Input impedance is 249 Ω)
		A0, B0	Frequency Reference (Pulse) Used by a pulse input to set the frequency reference.
		5G (~30kW) CM(37kW~)	Frequency Reference Common Terminal Common Terminal for Analog Frequency Reference Signal.
	External motor thermal detection	NT (~30kW) ET (37kW ~)	External motor thermal detection Motor thermal sensor input. Used to prevent motor from overheating by using a NTC or PTC thermal sensor.
		5G	Common for NT(or ET) Common Terminal for External motor thermal detection.
	RS485 terminal	C+, C-	RS485 signal High, Low RS485 signal (See RS485 communication in the manual for more details.)
		CM	RS485 common Common Ground. Terminal for RS485 interface.
	Output signal	Voltage	S0, S1,5G Programmable Voltage Output Voltage output for one of the following: Output Frequency, Output Current, Output Voltage, DC Link Voltage. Default is set to Output Frequency. (Maximum Output Voltage and Output Current are 0-12V and 1mA).
Contact		3A, 3C, 3B	Fault Contact Output Energizes when a fault is present. (AC250V, 1A; DC30V, 1A) Fault: 3A-3C Closed (3B-3C Open) Normal: 3B-3C Closed (3A-3C Open)
		A1~4, C1~4	Programmable Digital Output Defined by Programmable Digital Output terminal settings (AC250V, 1A; DC30V, 1A)

Note) M1~M8 terminals are User Programmable.

3.2.2 Wiring power terminals

◆ Wiring Precautions

- 1) The internal circuits of the inverter will be damaged if the incoming power is connected and applied to output terminals (U, V, W).
- 2) Use ring terminals with insulated caps when wiring the input power and motor wiring.
- 3) Do not leave wire fragments inside the inverter. Wire fragments can cause faults, breakdowns, and malfunctions.
- 4) For input and output, use wires with sufficient size to ensure voltage drop of less than 2%.
- 5) Motor torque may drop of operating at low frequencies and a long wire run between inverter and motor.
- 6) The cable length between inverter and motor should be less than 150m (492ft). Due to increased leakage capacitance between cables, overcurrent protective feature may operate or equipment connected to the output side may malfunction. (But for products of less than 30kW, the cable length should be less than 50m (164ft).)
- 7) The main circuit of the inverter contains high frequency noise, and can hinder communication equipment near the inverter. To reduce noise, install line noise filters on the input side of the inverter.
- 8) Do not use power factor capacitor, surge killers, or RFI filters on the output side of the inverter. Doing so may damage these components.
- 9) Always check whether the LCD and the charge lamp for the power terminal are OFF before wiring terminals. The charge capacitor may hold high-voltage even after the power is disconnected. Use caution to prevent the possibility of personal injury.
- 10) Do not connect with MC at output pare of inverter and make MC On/Off during operation. It can cause the Trip or damage of inverter

◆ Grounding

- 1) The inverter is a high switching device, and leakage current may flow. Ground the inverter to avoid electrical shock. Use caution to prevent the possibility of personal injury. The ground impedance for 200V class is 100 ohm with 400V class 10ohm.
- 2) Connect only to the dedicated ground terminal of the inverter. Do not use the case or the chassis screw for grounding.
- 3) The protective earth conductor must be the first one in being connected and the last one in being disconnected.
- 4) As a minimum, grounding wire should meet the specifications listed below. Grounding wire should be as short as possible and should be connected to the ground point as near as possible to the inverter.

Inverter Capacity		Grounding wire Sizes, AWG or kcmil (mm ²)	
kW	HP	200V Class	400V Class
5.5 ~ 7.5	7.5 ~ 10	10 (5.5)	12 (3.5)
11 ~ 15	15 ~ 20	6 (14)	8 (8)
18.5 ~ 30	25 ~ 40	4 (22)	6 (14)
37 ~ 55	50 ~ 75	-	4 (22)
75 ~ 90	100 ~ 125	-	2 (38)
110 ~ 132	150 ~ 200	-	1/0 (60)
160 ~ 280	250 ~ 350	-	4/0 (100)
315 ~ 375	400 ~ 600	-	300 (150)
450	700	-	400 (200)

3.2.3 Wires and terminal lugs

Refer to below for wires, terminal lugs, and screws used to connect the inverter power input and output.

Inverter capacity	Terminal screw size	Screw torque		Wire size				
				R(L1), S(L2), T(L3)		U, V, W		
		kgf · cm	lb · in	mm ²	AWG or kcmil	mm ²	AWG or kcmil	
200V	5.5kW(7.5HP)	M4	7.1 ~ 12.2	6.2~10.6	5.5	10	5.5	10
	7.5kW(10HP)	M5	24.5 ~ 31.8	21.2~27.6	8	8	8	8
	11kW(15HP)	M5			14	6	14	6
	15kW(20HP)	M6	30.6 ~ 38.2	26.6~33.2	22	4	22	4
	18.5kW(25HP)	M6			38	2	38	2
	22kW(30HP)	M8			61.2 ~ 91.8	53.1~79.7	38	2
	30kW(40HP)	M8	60	1/0			60	1/0
400V	5.5kW(7.5HP)	M4	7.1 ~ 12.2	6.2~10.6	3.5	12	3.5	12
	7.5Kw(10HP)	M4			3.5	12	3.5	12
	11 kW(15HP)	M4			5.5	10	5.5	10
	15 kW(20HP)	M6	30.6~38.2	26.6~33.2	8	8	8	8
	18.5kW(25HP)	M6			14	6	14	6
	22~30kW (30~40HP)	M8	61.2~91.8	53.1~79.7	22	4	22	4
	37~55kW (50~75HP)	M8	67.3~87.5	58.4~75.9	38	2	38	2
	75~90kW (100~125HP)	M10	89.7~122.0	77.9~105.9	60	1/0	60	1/0
	110~132Kw (150~200HP)	M12	182.4~215.0	158.3~186.6	100	4/0	100	4/0
	160kW(250HP)	M12			150	300	150	300
	220kW(300HP)	M12			200	400	200	400
	280kW(350HP)	M12	182.4~215.0	158.3~186.6	250	500	250	500
	315kW(400HP)	M12			325	700	325	700
	375kW(500HP)	M12			2×200	2×400	2×200	2×400
450kW(600HP)	M12	2×250			2×500	2×250	2×500	

* Apply the rated torque to terminal screws.

* Loose screws can cause of short circuit or malfunction. Tightening the screw too much can damage the terminals and cause a short circuit or malfunction.

* Use copper wires only with 600V, 75℃ ratings. For 7.5~11kW 240V type inverters, R(L1), S(L2), T(L3) and U, V, W terminals are only for use with insulated ring type connector.

Power and Motor Connection Example (5.5~30kW inverters)

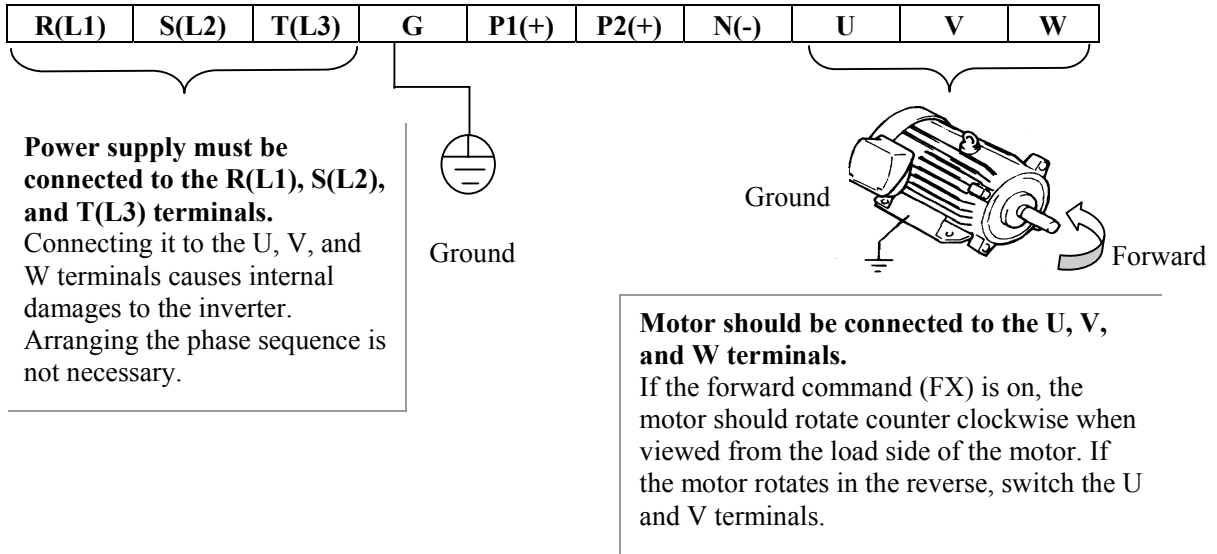

3.2.4 Control circuit wiring

1) Wiring Precautions

CM and 5G terminals are insulated each other. Do not connect these terminals together or to the power ground.

Use shielded wires or twisted wires for control circuit wiring, and separate these wires from the main power circuits and other high voltage circuits (200V relay sequence circuit).

It is recommended to use the cables of 0.0804mm² (28 AWG) ~ 1.25mm² (16 AWG) for TER1, TER2 control terminals and the cables of 0.33mm² (22 AWG) ~ 2.0mm² (14 AWG) for TER3, TER4 control terminals.

2) Control terminal layout

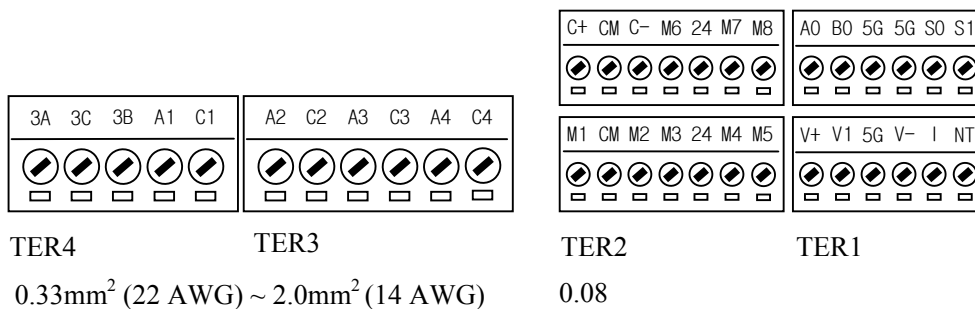

3) Sink mode(NPN mode) / Source mode(PNP mode)

SV-iP5A provides Sink/Source(NPN/PNP) modes for sequence input terminal on the control circuit. The logic of the input terminal is settable to Sink mode(NPN mode) / Source mode(NPN mode) by using the J1 switch. Connection method is shown below.

(1) Sink mode(NPN mode)

- Put J1 switch down to set to Sink mode(NPN mode). CM terminal (24V GND) is common terminal for contact signal input.
- The factory default is Sink mode(NPN mode).

(2) Source mode(PNP mode) - Internal Power Supply used

- Put J1 switch up to set to Source mode(PNP mode). Terminal 24 (24V Power Supply) is common terminal for contact input signal.

(3) Source mode(PNP mode) - External Power Supply used

- Put J1 switch up to set to Source mode(PNP mode).
- To use external 24V Power Supply, make a sequence between external Power Supply (-) terminal and CM(24V GND) terminal.

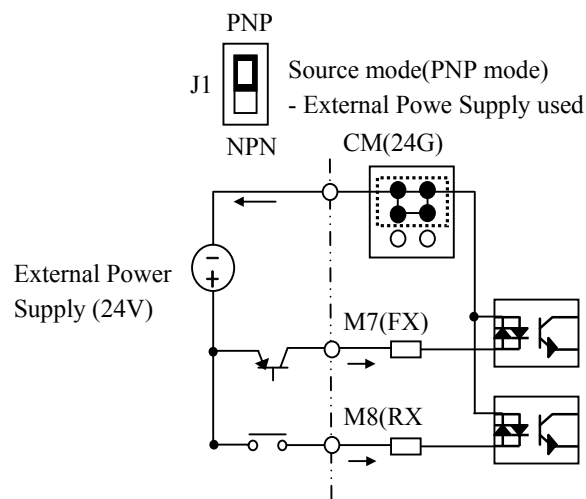
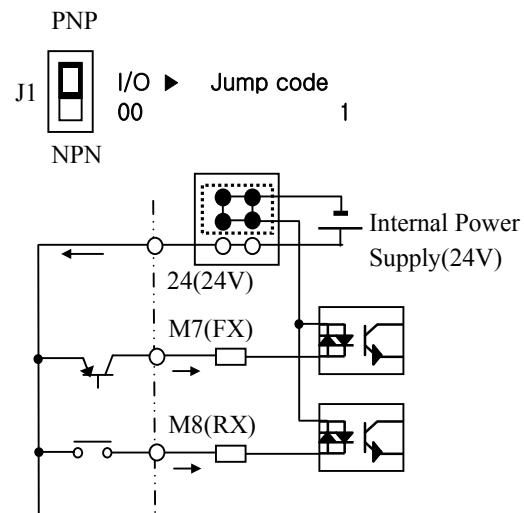
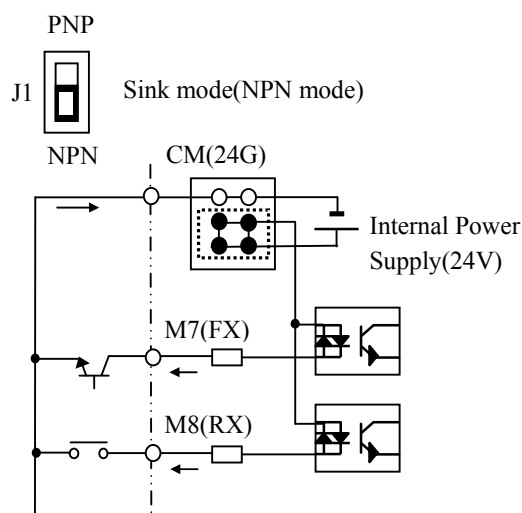

3.2.5 RS485 circuit wiring

TER 2

C+	CM	C-	M6	24	M7	M8
M1	CM	M2	M3	24	M4	M5

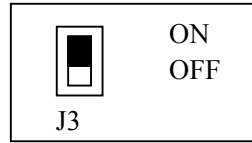

Use C+ (RS485 signal High), C- (RS485 signal LOW) in TER 2. Turn the J3 switch ON (Upward) to connect the termination resistor (120 ohm). J3 switch is on the left side of the TER2.

Item	Specification
Transmission type	Bus method, Multi drop Link System
Applicable inverter	SV-iP5A series
Number of inverters	Max.31
Transmission distance	Within 1200m Max. (700m desired)
Recommendable cable	0.75mm ² (18AWG), Shield Type Twisted-pair Wire

Item	Specification
Installation	C+, C-, CM terminals on the control terminal block
Power supply	Insulated from the inverter power supply

3.2.6 Check points on wiring

- 1) Electrical or mechanical interlock of MC1 and MC2 is required for Inverter Bypass Operation. Otherwise, chattering may occur or input power may flow to inverter output, damaging the inverter.
- 2) Make the sequence to disable the Auto restart after power failure if required. Otherwise, inverter will be automatically restarted.
- 3) Do not apply the voltage directly to control circuit input terminals such as FX, RX.

CHAPTER 4 - OPERATION

4.1 Programming Keypads

4.1.1 LCD Keypad

LCD keypad can display up to 32 alphanumeric characters, and various settings can be checked directly from the display. The following is an illustration of the keypad.

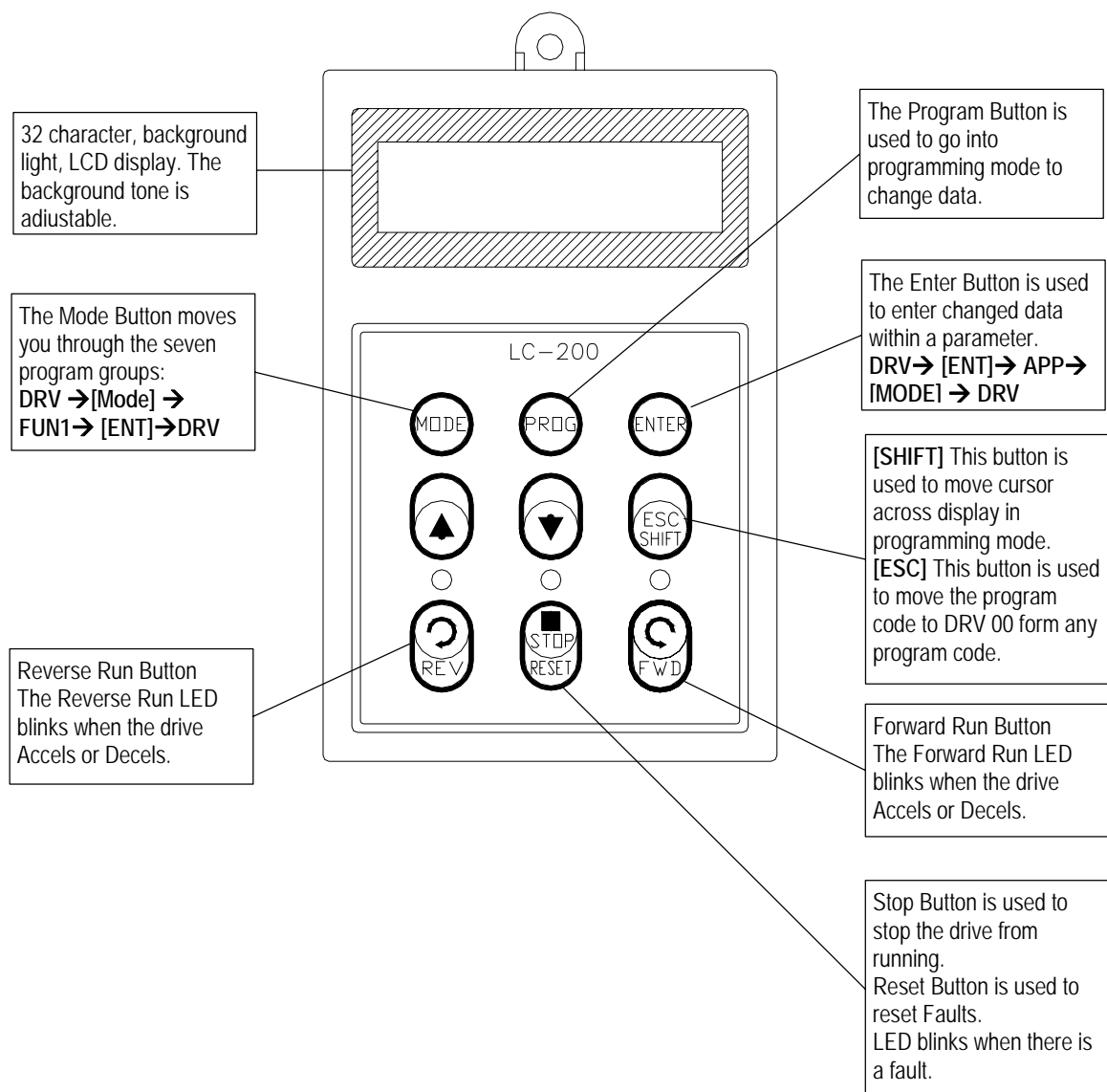

Chapter 4 - Operation

Detail description

1) LCD Keypad Display

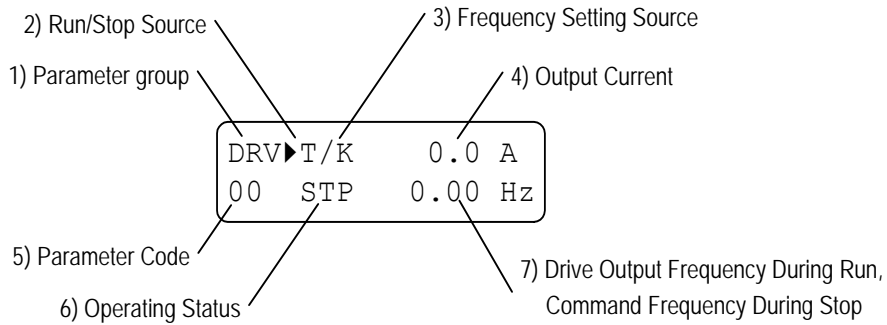

Displays	Description
1) Parameter Group	Displays the parameter group. There are DRV, FU1, FU2, I/O, EXT, COM, APP groups.
2) Run/Stop Source	Displays the source of motor Run and Stop K : Run/Stop using FWD, REV buttons on keypad T : Run/Stop using control terminal input FX, RX R : Run/Stop using RS485 O : Run/Stop via option board
3) Frequency Setting Source	Displays the source of command frequency setting K : Frequency setting using keypad V : Frequency setting using V1 (0~12V or -12~12V) or V1 + I terminal I : Frequency setting using I (4~20mA) terminal P : Frequency setting using Pulse input R : Frequency setting using RS485 U : Up terminal input when Up/Down operation is selected D : Down terminal input when Up/Down operation is selected S : Stop status when Up/Down operation is selected O : Frequency setting via Option board X : Frequency setting via Sub board J : Jog terminal input 1 ~ 15 : Step frequency operation (except Jog)
4) Output Current	Displays the Output Current during operation.
5) Parameter Code	Displays the code of a group. Use the ▲(Up), ▼(Down) key to move through 0~99 codes.
6) Operating Status	Displays the operation information. STP : Stop Status FWD : During Forward operation REV : During Reverse operation DCB : During DC Braking LOP : Loss of Reference from Option Board (DPRAM fault) LOR : Loss of Reference from Option Board (Communication network fault) LOV : Loss of Analog Frequency Reference (V1: 0~12V, -10~12V) LOI : Loss of Analog Frequency Reference (I: 4~20mA) LOS : Loss of Reference from Sub-Board
7) Inverter Output Frequency/ Command Frequency	Displays the Output Frequency during run. Displays the Command Frequency during stop.

4.1.2 Parameter setting and changing

- 1) Press [**MODE**] key until the desired parameter group is displayed.
- 2) Press [**▲**] or [**▼**] keys to move to the desired parameter code. If you know the desired parameter code, you can set the code number of each parameter group in “Jump code”, except DRV group.
- 3) Press [**PROG**] key to go into the programming mode, the cursor starts blinking.
- 4) Press [**SHIFT/ESC**] key to move the cursor to the desired digit.
- 5) Press [**▲**] or [**▼**] keys to change the data.
- 6) Press [**ENT**] key to enter the data. The cursor stops blinking.

Note: Data cannot be changed when 1) the parameter is not adjustable during the inverter is running (see the function list), or 2) Parameter Lock function FU2-94 [Parameter Lock] is activated.

EX) Changing Accel time from 10 sec to 15 sec

- 1) LCD keypad

DRV ▶ Acc. time
01 10.0 sec

Move to the desired code to change.

DRV ▶ Acc. time
01 1█.0 sec

Press the [**PROG**] key.
A Cursor (█) will appear.

DRV ▶ Acc. time
01 10.█ sec

Use the [**SHIFT**] key to move the cursor.

DRV ▶ Acc. time
01 15.0 sec

Change the data using [**▲**], [**▼**] keys.

DRV ▶ Acc. time
01 15.0 sec

Press the [**ENT**] key to save the value into memory.
The Cursor will disappear.

4.1.3 Parameter groups

The iP5A series inverter has 5 parameter groups separated according to their applications as indicated in the following table.

The iP5A series inverter provides two kinds of keypad. One is 32-character alphanumeric LCD keypad and the other is 7-Segment LED keypad.

Parameter Group	LCD Keypad	Description
Drive Group	DRV	Command Frequency, Accel/Decel Time etc. Basic function Parameters
Function 1 Group	FU1	Max. Frequency, Amount of Torque Boost etc. Parameters related to basic functions
Function 2 Group	FU2	Frequency Jumps, Max/Min Frequency Limit etc. Basic Application Parameters
Input / Output Group	I/O	Programmable Digital Input/Output Terminal Setting, Auto Operation etc. Parameters needed for Sequence Operation
Application Group	APP	PID, MMC (Multi-Motor Control), 2 nd motor operation etc. Parameters related to Application function

Refer to the function descriptions for detailed description of each group.

1) Parameter Navigation (LCD Keypad)

The parameter group moves directly to DRV group by pressing [SHIFT] key in any parameter code.

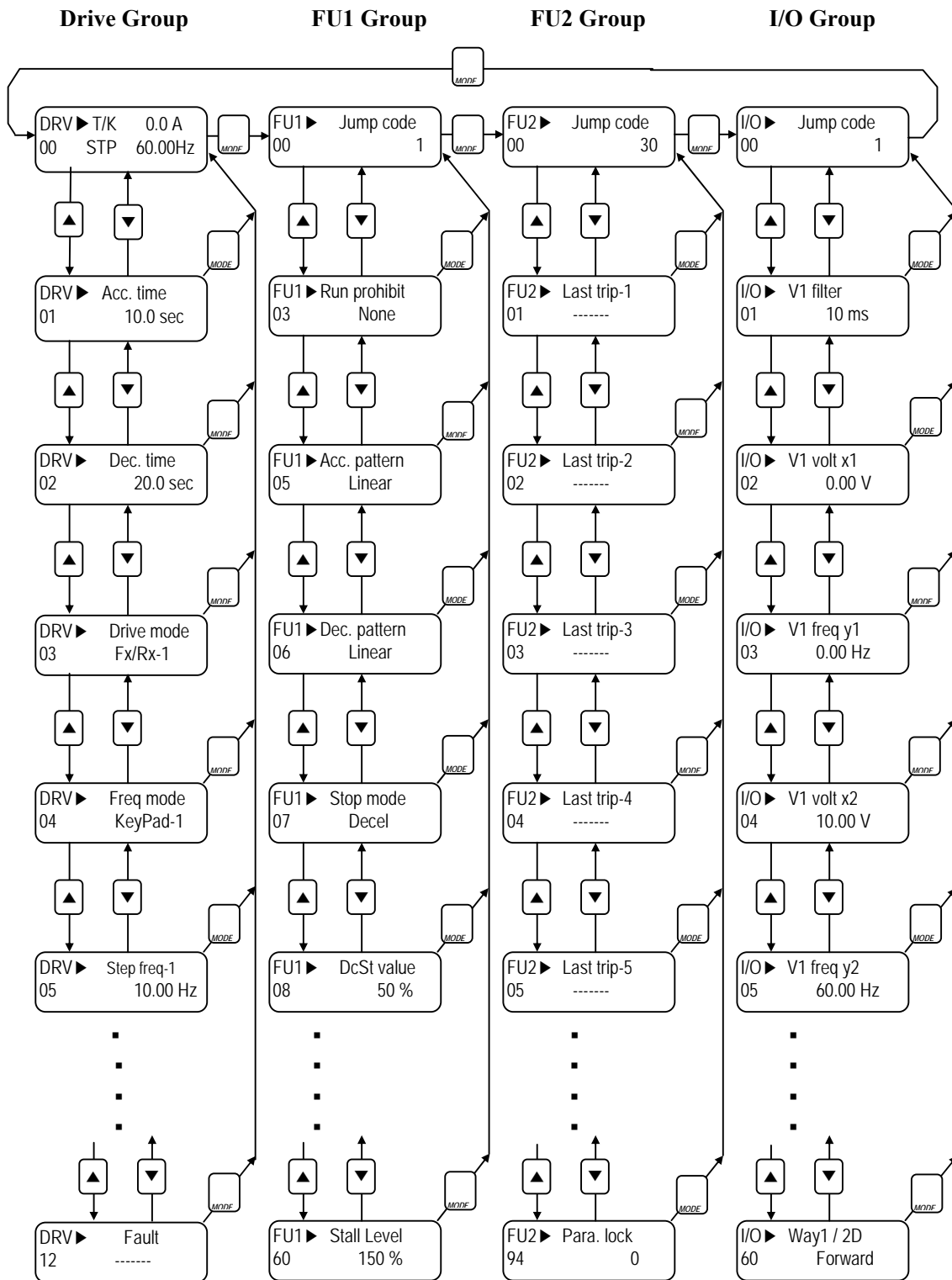

Note: This figure shows the group and code navigation through LCD display keypad. It can be different from the actual display due to the group addition or code change.

4.2 Operating Example

4.2.1 Easy Start Operation

Easy Start Operation is activated by pressing STOP key on the Keypad for 2~3 seconds and inverter begins operation via Keypad (FWD/REV RUN/STOP). **Drive mode is preset to V/F and reference frequency to JOG.**

4.2.2 Operation via Control terminal + Keypad

Setting: DRV-03 [Drive Mode (Run/Stop method)] = **Fx/Rx-1**

DRV-04 [Frequency Mode (Freq. setting method)] = **Keypad**

With above setting, Freq setting via terminal & Run/Stop via Keypad disabled

1) Check the LCD display when Power ON. Otherwise, change the setting correctly as shown above.

DRV ▶ T/K	0.0 A
00 STP	0.00Hz

2) Turn the FX (or RX) terminal ON. Then FWD (or REV) LED will be lit.

DRV ▶ T/K	0.0 A
00 FWD	0.00Hz

3) When setting the Ref. Freq to 60 Hz using **PROG/ENT/SHIFT**, **▲** keys, the motor will rotate at 60Hz. FWD (or REV) LED will be flickering during Acceleration/ Deceleration.

DRV ▶ Cmd. freq	0.00Hz
00	■

 →

DRV ▶ Cmd. freq	60.00Hz
00	□

 →

DRV ▶ T/K	5.0 A
00 FWD	60.00Hz

4) Turn the FX (or RX) terminal Off. Then Stop LED will be lit.

DRV ▶ T/K	0.0 A
00 STP	60.00Hz

Note) To enable Run/Stop via keypad & Freq setting via control terminal...

Setting: DRV-03 [Drive Mode (Run/Stop method)] = Keypad

DRV-04 [Frequency Mode (Freq. setting method)] = V1, V1S or I

Operation Example (1)		Freq Setting via Keypad + Run/Stop via Terminal (FX/RX)	
[Operation condition]			
<ul style="list-style-type: none"> - Control mode: V/F control - Ref. Frequency: 50[Hz] setting via keypad - Accel/Decel time: Accel – 10 [sec], Decel – 20 [sec] - Drive mode: Run/Stop via FX/RX terminal, Control terminal: NPN mode 			
[Wiring]			
Step	Parameter setting	Code	Description
1	Drive Mode	DRV-3	Set it to 1 FX/RX-1.
2	Frequency Mode	DRV-4	Set it to 0 Keypad-1.
3	50[Hz] freq command setting	DRV-0	Set freq command 50[Hz] via Keypad.
4	Accel/Decel time	DRV-1 DRV-2	Set Accel time to 10 [sec] in DRV-1. Set Decel time to 20 [sec] in DRV-2.
5	Terminal FX (M7)	I/O-26	Motor starts to rotate in Forward direction at 50Hz with Accel time 10 [sec] when FX terminal is turned ON. Motor decelerates to stop with Decel time 20[sec] when FX terminal is turned OFF.
6	Terminal RX (M8)	I/O-27	When RX terminal is turned ON motor starts to rotate in Reverse direction at 50[Hz] with Accel time 10 [sec]. When it is OFF, motor decelerates to stop with Decel time 20 [sec].

4.2.3 Operation via Control Terminal

Setting: **DRV-03** [Drive Mode (Run/Stop method)] = **1 (Fx/Rx-1)**
DRV-04 [Frequency Mode (Freq. setting method)] = **2 (V1)**

1) Check the LCD display when Power ON. Otherwise, change the setting correctly as shown above.

DRV ▶ T/V	0.0 A
00 STP	0.00Hz

2) Turn the FX (or RX) terminal ON. Then FWD (or REV) LED will be lit.

DRV ▶ T/V	0.0 A
00 FWD	0.00Hz

3) Set the frequency using V1 (Potentiometer), Output freq (60Hz). Rotating direction (FWD or REV) and output current (5A) will be displayed on the LCD.

DRV ▶ T/V	5.0 A
00 FWD	60.00Hz

4) Output freq value is decreasing when turning the potentiometer counterclockwise. Inverter output stops at 0.00Hz and motor is stopped.

DRV ▶ T/V	0.0 A
00 FWD	0.00Hz

5) Turn FX (or RX) terminal OFF.

DRV ▶ T/V	0.0 A
00 STP	0.00Hz

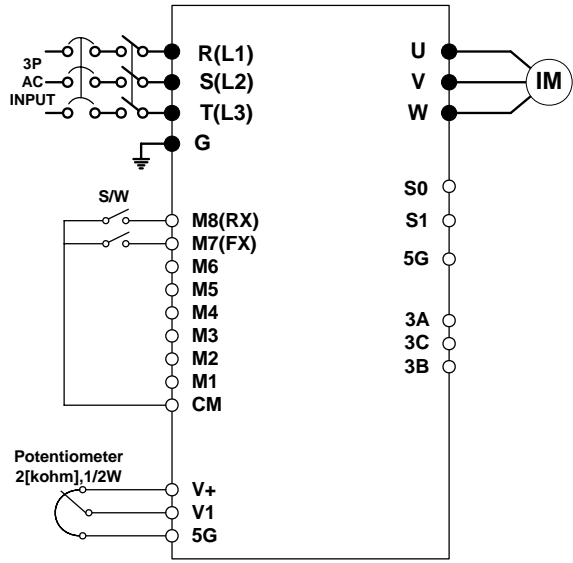
Operation Example (2)	Analog Voltage Input (V1) + Operation via Terminal (FX/RX)		
<p>[Operation condition]</p> <ul style="list-style-type: none"> - Control mode: V/F control - Reference Frequency: 50[Hz] analog input via V1 (Potentiometer) - Accel/Decel time: Accel – 10 [sec], Decel – 20 [sec] - Drive mode: Run/Stop via FX/RX terminal, Control terminal: NPN mode 			
<p>[Wiring]</p> 			
Step	Parameter setting	Code	Description
1	Drive Mode	DRV-3	Set it to 1 Fx/Rx-1.
2	Frequency Mode	DRV-4	Set it to 2 V1 Analog input.
3	50[Hz] freq command setting	DRV-0	Set freq command 50[Hz] via V1 (potentiometer).
4	Accel/Decel time	DRV-1 DRV-2	Set Accel time to 10 [sec] in DRV-1. Set Decel time to 20 [sec] in DRV-2.
5	Terminal FX (M7)	I/O-26	Motor starts to rotate in Forward direction at 50Hz with Accel time 10 [sec] when FX terminal is turned ON. Motor decelerates to stop with Decel time 20[sec] when FX terminal is turned OFF.
6	Terminal RX (M8)	I/O-27	When RX terminal is turned ON motor starts to rotate in Reverse direction at 50[Hz] with Accel time 10 [sec]. When it is OFF, motor decelerates to stop with Decel time 20 [sec].

4.2.4 Operation via Keypad

Setting: DRV-03 [Drive Mode (Run/Stop method)] = 0 (Keypad)

DRV-04 [Frequency Mode (Freq. setting method)] = 0 (Keypad-1)

1) Check the LCD display when Power ON. Otherwise, change the setting as shown above.

DRV ▶ K/K	0.0 A
00 STP	0.00Hz

2) Set the Ref. Freq to 60 Hz using **PROG/ENT/SHIFT**, **▲** keys. Set freq is displayed during stop.

DRV ▶ K/K	0.0 A
00 STP	60.00Hz

3) When pressing **FWD/REV** key, motor starts running and output freq and output current are displayed.

DRV ▶ K/K	5.0 A
00 FWD	60.00Hz

4) Press **STOP/RESET** key. Then motor decelerates to stop. Set freq 60Hz is displayed.

DRV ▶ K/K	0.0 A
00 STP	60.00Hz

4.3 Various function setting & Description

4.3.1 Basic function parameter setting

It is the basic function setting. All settings are factory defaults unless users make change. It is recommended to use factory setting value unless the parameter change is necessary.

1) Common parameter setting

The following table shows common parameter setting that should be checked before use regardless of control mode.

Parameter Name	Code	Description
Line Freq.	FU1-29	Sets a freq of the inverter input power source.
Base Frequency	FU1-31	Sets the Motor Base Frequency ¹⁾ .
Motor Rated Voltage	FU1-50	Sets the Motor Rated Voltage ¹⁾ .
Motor Selection	FU2-40	Selects motor and voltage rating suitable to the desired inverter.
Motor parameters	FU2-41 ~ 46	Basic parameter value setting when selecting the motor rating. Note: If there is any discrepancy between parameter preset value and the actual motor parameter value, change the parameter value according to the actual motor.
Drive Mode	DRV-3	Operation via Keypad, Fx/Rx-1, Fx/Rx-2 and Int 485 setting.
Frequency Mode	DRV-4	Frequency reference source setting parameter
Accel/Decel time setting	DRV-1, DRV-2	Accel/Decel time setting

1) If FU1-31 and FU1-50 are set higher than motor nameplate value, it may cause motor overheat and if it is set smaller than that, it may cause Over voltage trip during deceleration. Make sure to enter the actual motor value.

2) V/F control

FU2-60 [Control mode] is set to 0 “V/F” as factory setting. Operation via V/F control is activated after the above common parameter setting is done and the followings are set.

Parameter Name	Code	Description
Starting freq.	FU1-32	Set frequency to start the motor.
Torque boost	FU2-67	Manual or Auto torque boost settable in this parameter
Torque boost value	FU2-68, FU2-69	If FU1-67 [torque boost] is set to “manual”, user sets the desired value and the direction in code FU1-68 and 69.

3) Slip compensation

Operation is done via Slip compensation if FU2-60 is set to 1 {Slip compen}. This control keeps motor speed constant regardless of load change.

4) Sensorless vector control

Set FU2-60 to “Sensorless” to enable Sensorless vector control. It is strongly recommended to perform **Auto-tuning** before starting Sensorless control in order to maximize performance.

Parameter Name	Code	Description
Control method selection	FU2-60	Select Sensorless.
P, I gain for sensorless control	FU2-65, FU2-66	Set gain for Sensorless.
Starting freq	FU1-32	Starting freq of the motor

Note) No-load current for Sensorless control is not entered by auto-tuning. Therefore enter the no-load current value in V/F operation. When other than LS standard motor is used, set this value according to the motor in use for better performance.

5) Auto-tuning of motor constant

This parameter enables auto-tuning of the motor constants. If FU2-61 is set to Yes and press the enter key, **Rs**, **Lsigma** values begin tuning with the motor stopped. Refer to motor nameplate for the rest of other parameters.

Parameter Name	Code	Description
Auto-tuning	FU2-61	No, Yes

Note) Motor no-load current and slip freq should be set correctly for safe and better performance. Be sure to check these values and set them properly. Refer to Chapter 5, FU2-40~66 for more.

4.3.2 Advanced function setting

SV-iP5A inverter features advanced function parameters to maximize efficiency and performance of the motor. It is recommended to use the factory setting unless parameter value change is inevitable.

1) V/F control

Parameter Name	Code	Description
V/F Pattern	FU1-40	Use it according to load characteristics. If User V/F is selected, user can select the optimum output V/F characteristic for the application and load characteristics in [FU1-41]~[FU1-48].
Dwell operation	FU2-07 FU2-08	Used to output torque in an intended direction. Inverter stops acceleration for the preset [FU2-08] Dwell time while running at Dwell frequency [FU2-07] and starts acceleration at commanded frequency. Setting [FU2-08] Dwell time to 0 disable the Dwell operation.
Jump Frequency	FU2-10 FU2-11~16	When it is desired to avoid resonance attributable to the natural frequency of a mechanical system, these parameters allow resonant frequencies to be jumped. Up to three areas can be set, with the jump frequencies set to either the top or bottom point of each area. To enable the function, set [FU2-10] to ‘Yes’ and set the value in [FU2-11]~[FU2-16].
Accel/Decel pattern S-curve	FU1-2, 3 FU1-4, 5	This pattern has an effect on the prevention of cargo collapse on conveyor etc and reduction in an acceleration/ deceleration shock.

2) Sensorless vector control

Related parameters for starting in **Sensorless vector control** when FU2-60 [Control Mode Selection] is set to Sensorless.

Parameter Name	Code	Description
When starting	FU2-64	Pre-excitation time setting
	I/O-20~27	Programmable Digital Input terminals define

3) Parameters to monitor motor and inverter status

Parameter Name	Code	Description
Output current/ motor speed	DRV-8~9	Displays output current and motor rpm.
DC link voltage	DRV-10	Displays DC link voltage.
User display selection (Voltage and watt)	DRV-11 FU2-81	Either output voltage or power selected in FU2-81 is displayed in DRV-11.
Fault display	DRV-12	Displays the current inverter fault.
TAR / OUT Freq. display	DRV-14	Displays Target freq. for Accel/Decel & Output freq during Accel/Decel.
REF/FBK display	DRV-15	Displays PID Reference/ Feedback frequency display.
Speed (Hz / Rpm) selection	DRV-16	Selects inverter output speed unit [Hz or Rpm]
PID parameter	DRV-18	Displays related parameters of PID controller.
AD parameter	DRV-19	Displays inverter analog input value to AD value.
EXT - PID parameter	DRV-20	Displays related parameters of EXT-PID controller.

Note) DRV-15, DRV-18 only displayed when APP-02 [proc PI mode] is set to “Yes.” DRV-20 only displayed when APP-80 [Ext PI mode] is set to “Yes.”

5) Parameter initialize

Parameter Name	Code	Description
Software version	FU2-82	Displays the inverter software version.
Parameter Read/Write/Initialize/ Lock	FU2-91 FU2-92 FU2-93 FU2-94 FU2-95	[FU2-91], [FU2-92]: Copying parameters from other inverter [FU2-93]: Initializing parameters to factory setting values [FU2-94]: Parameter write disabled [FU2-95]: Parameter save

Note: Motor parameters (FU2-40~46, FU2-62~63) returned to factory setting once Parameter Read/Write is executed.

6) Protection & Trip level setting

Parameter Name	Code	Description
Electronic thermal	FU1-60 FU1-61 FU1-62 FU1-63	Protection of the motor from overheating without the use of external thermal relay. Refer to parameter descriptions for more detail.
Overload alarm & trip	FU1-64 FU1-65 FU1-66 FU1-67 FU1-68	Warning alarm outputs and displays the trip message when overcurrent above the threshold value keeps on.
Stall prevention	FU1-70 FU1-71	Set the output current level at which the output freq will be adjusted to prevent the motor from stopping due to over-current etc. It activates during accel/ constant speed/decel to prevent the motor stall.

7) Starting / Accel/ Decel / Stopping pattern setting

Parameter Name	Code	Description
Accel/Decel pattern	FU1-02 FU1-03	2 types of Accel/Decel pattern: 'S-curve', 'U-curve' settable according to application and load characteristic. If 'S-curve' is selected, the desired value of [FU1-4], [FU1-5] is settable.
Starting/Stopping method	FU1-20 FU1-23	4 types of stopping method 'Decel', 'DC-brake', 'Free-run', 'Flux Brake' selectable. If 'DC-brake' is selected, the desired value of [FU1-21, 22], [FU1-24]~ [FU1-27] is settable. See function description of chapter 5 for more details.
Frequency Limit selection	FU1-33 FU1-34 FU1-35	Limits the active frequency. Inverter operates at the freq range between upper freq limit [FU1-35] and bottom freq limit [FU1-34] and higher/ lower freq value is entered, it is automatically replaced by limit value. Setting range: [FU1-30] Maximum freq to [FU1-32] starting freq.

8) Operation-starting method

Parameter Name	Code	Description
Starting method	FU2-20 FU2-21 FU2-25 FU2-26	Motor starting method: [FU2-20]: Power-on run, [FU2-21] Restart after Fault Reset, [FU2-25] Number of Auto Restart Attempt [FU2-26] Delay Time Before Auto Restart See parameter description for more details.
Speed Search Selection	FU2-22 FU2-23 FU2-24	Speed search function is available during Accel, trip, instant power failure, restart after fault reset and Speed search at auto restart. See parameter description for more details.

4.3.3 Application function setting

1) PID operation

Inverter can be used to exercise process control, e.g. flow rate, air volume or pressure via PID feedback control.

Parameter Name	Code	Description
PID control setting	APP-02 ~ APP-17	Parameters for PID control setting

☞ See Chapter 6. PID feedback operation.

2) Ext PID operation

It is used for External PID feedback control.

Parameter Name	Code	Description
ExtPID setting	APP-80 ~ APP-97	Parameters for Ext PID

☞ See Chapter 6. External PID operation.

3) Pre PID operation

It helps to begin smooth start of the PID control.

Parameter Name	Code	Description
PrePID setting	APP-74 ~ APP-76	Parameters for Pre PID operation

☞ See Chapter 6. Pre PID operation.

4) MMC operation

Inverter controls a whole system by controlling Main motor connected directly to the inverter and Aux motors connected to the inverter relays and operated via relay On/Off.

Parameter Name	Code	Description
MMC setting	APP-40 ~ APP-71 I/O-20 ~ I/O-27	Parameters for MMC operation

☞ See Chapter 6. MMC operation.

5) Jog and Multi-speed operation

Parameter Name	Code	Description
Multi function input terminal setting	I/O-20 ~27	If I/O-20 ~27 are set to Speed-H, Speed-M, Speed-L, multi- speed operation up to speed 17 is available.
Filter time constant for input terminal	I/O-29	Effective for eliminating noise in the freq. Setting circuit
Speed reference value	DRV-05 ~07 I/O-31 ~ I/O-42	Speed reference value for each step setting
Accel/Decel time setting for each step	I/O-50 ~ 63	Accel/Decel time for each step setting
Jog freq.	I/O-30	Jog freq for jog operation setting

Speed-X	Speed-H	Speed-M	Speed-L	JOG	Speed Command	Parameter value
0	0	0	0	0	Speed 0	DRV-00
0	X	X	X	1	Jog freq.	I/O-20
0	0	0	1	0	Speed -1	DRV-05
0	0	1	0	0	Speed -2	DRV-06
..
..
1	1	0	1	0	Speed -13	I/O-40
1	1	1	0	0	Speed -14	I/O-41
1	1	1	1	0	Speed -15	I/O-42

6) 2nd motor operation

2nd function setting is required to run the two motors by one inverter by exchange. If the terminal defined for 2nd function signal input is turned ON, 2nd motor operation is valid.

Parameter Name	Code	Description
Programmable Digital Input terminals setting	I/O-20 ~27	2 nd motor operation is available with Programmable Digital Input terminals M1 ~ M8 set to 7 {2 nd Func}.
Parameter setting for 2 nd motor operation	APP-20 ~ APP-29	Setting parameters necessary to operate 2 nd motor such as base freq., Accel/Decl time, Stall.

7) Energy-saving operation

FU1-51 [Energy Save Level] tunes the inverter output voltage to minimize the inverter output voltage during constant speed operation. Appropriate for energy-saving applications such as fan, pump and HVAC.

4.4 Operation Example

Operation Example (1)	V/F Control + Analog Voltage Input (V1) + Operation via Terminal (FX/RX)		
<p>[Operation condition]</p> <ul style="list-style-type: none"> - Control mode: V/F control - Frequency command: 50[Hz] analog input via V1 terminal - Accel/Decel time: Accel – 15 [sec], Decel – 25 [sec] - Drive mode: Run/Stop via FX/RX terminal, Control terminal: NPN mode 			
<p>[Wiring]</p>			
Step	Parameter setting	Code	Description
1	Control Mode Selection	FU2-60	Set it to 0 {V/F}.
2	Drive Mode	DRV-3	Set it to Fx/Rx-1.
3	Frequency Mode	DRV-4	Set V1 Analog input value in frequency mode.
4	50[Hz] freq command setting	DRV-0	Set freq command 50[Hz] via V1 (potentiometer).
5	Accel/Decel time	DRV-1 DRV-2	Set Accel time to 15 [sec] in DRV-2. Set Decel time to 25 [sec] in DRV-3.
6	Terminal FX	I/O-26	Motor starts to rotate in Forward direction at 50Hz with Accel time 15 [sec] when FX terminal is turned ON. Motor decelerates to stop with Decel time 25[sec] when FX terminal is turned OFF.
7	Terminal RX	I/O-27	When RX terminal is turned ON motor starts to rotate in Reverse direction at 50[Hz] with Accel time 15 [sec]. When it is OFF, motor decelerates to stop with Decel time 25 [sec].

Operation Example (2)		2 nd motor operation	
<p>[Operation condition]</p> <ul style="list-style-type: none"> - Control mode: V/F control - 1st motor + 2nd motor Operation by exchange using [2nd Func] (Set Value different) - Frequency command: Using Multi-step operation 1st motor --- 50[Hz] as main speed 2nd motor --- 20[Hz] with M1 terminal set as multi- step operation) - Accel/Decel time: 1st motor --- Accel time: 15[sec], Decel time: 25 [sec] 2nd motor --- Accel time: 30[sec], Decel time: 40 [sec] - Drive mode: Run/Stop via FX/RX, Control terminal: NPN mode 			
<p>[Wiring]</p>			
Step	Parameter setting	Code	Description
1	Control Mode Selection	FU2-60	Set it to 0 {V/F}.
2	Drive mode	DRV-3	Set it to Fx/Rx-1.
3	Frequency Mode setting	DRV-4	Set it to 0 {keypad-1}. 1 st motor freq setting
4	Programmable digital input terminal M1	I/O-20	Set M1 to 2nd Func.
5	Programmable digital input terminal M2	I/O-21	Set M2 to Speed-L. 2 nd motor freq setting
6	Freq setting for 1 st motor	DRV-0	Set it to 50[Hz].
7	Accel/Decel time setting for 1 st motor	DRV-1, DRV-2	Set Accel/Decel time to 15[sec]/25[sec].
8	Freq setting for 2 nd motor	DRV-5	Set it to 10[Hz].
9	Accel/Decel time setting for 2 nd motor	APP-20, APP-21	Set Accel/Decel time to 30[sec]/50[sec].
10	1 st motor operation		Set it as main motor by turning M1, M2, Output relay OFF. Run the motor in FWD/REV direction using FX/RX terminal.
11	2 nd motor operation		Set 2 nd motor parameters by turning terminal M1 ON. Change the freq setting to 20[Hz] by turning terminal M2 ON. Change to 2 nd motor terminal by turning output relay ON. Run the motor in FWD/REV direction by terminal FX/RX.

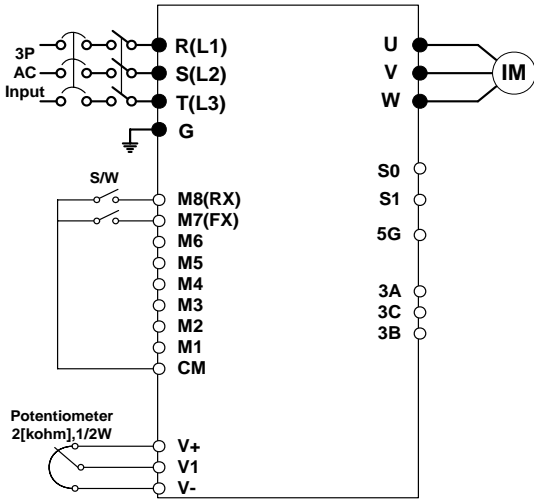
Operation Example (3)	V/F control + Analog input (V1S) + Operation via terminal FX/RX		
<p>[Operation condition]</p> <ul style="list-style-type: none"> - Control mode: V/F control - Frequency command: Setting 50[Hz] via Analog input (V1S) - Accel/Decel time: Accel time 15 [sec], Decel time 25 [sec] - Drive mode: Run/Stop via FX/RX, Control terminal: NPN mode 			
<p>[Wiring]</p> 			
Step	Parameter setting	Code	Description
1	Control mode selection	FU2-60	Set it to 0 {V/F}.
2	Drive mode	DRV-3	Set it to 1 {Fx/Rx-1}.
3	Frequency mode	DRV-4	Set it to 3 {V1S}.
4	Operating frequency command 50[Hz] setting	DRV-0	Set 50[Hz] via potentiometer (V1S).
5	Accel/Decel time setting	DRV-1 DRV-2	Set Accel time to 15[sec] in DRV-1 with decal time to 25[sec] in DRV-2.
6	FX terminal (M7)	IO-26	When FX terminal is turned ON, motor rotating in forward direction starts running at 50[Hz] for 15 [sec]. When FX terminal is turned OFF, motor decelerates to stop for 25[sec].
7	RX terminal (M8)	IO-27	When RX terminal is turned ON, motor rotating in reverse direction starts running at 50[Hz] for 15[sec]. When RX terminal is turned OFF, motor decelerates to stop for 25 [sec].

☞ **Note:** V1S mode enables Forward/Reverse rotation using $\pm 12V$ power via Analog input command. Refer to Chapter 6, Parameter description of DRV-00 for details.

☞ **Note:** Use V1 instead of V1S mode when FWD/REV Run Prevention is active. V1S mode enables the motor to run both FWD/REV directions.

☞ **Note:** If the inverter is operated without wiring a motor, trip occurs as below because the protection function is active automatically. In this case, refer to the related parameters(FU1 57 ~ 59). Trip is reset if the inverter is powered down and up once again.

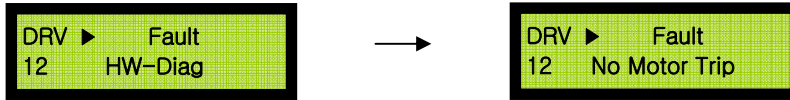



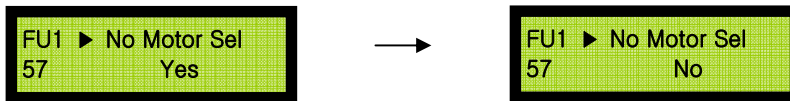

In case that a simple trial run is needed such as a check on basic operation state without a wiring a motor, FU1-57(No Motor Sel) should be set to [No].



CHAPTER 5 - PARAMETER LIST

5.1 Parameter groups

The parameters of SV-IP5A Series are divided into 5 function groups in accordance with the application. Their names, principal contents and LCD keypad displays are shown below.

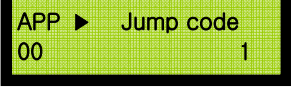
Name of Group	LCD Keypad Display	Description
Drive Group [DRV]		Target Frequency and Accel/ Decel Time, etc. Basic parameters
Function1 Group [FU1]		Maximum Frequency and Protection, etc Parameters regarding basic functions
Function2 Group [FU2]		Frequency Jump and Frequency Limit, etc Parameters regarding application functions
Input/Output Group [I/O]		Programmable Digital terminal Define and Analog Command, etc Parameters necessary for sequence configuration
Application Group [APP]		PID, MMC, and 2 nd motor, etc Parameters regarding application functions

5.2 Parameter list

[DRV Group]

CODE	Comm. Addr	Description	LCD Keypad Display	Setting Range	Factory Default	Adj. During Run	Page	
DRV-00 (1)	9100	Command Frequency (Output Frequency during motor run, Reference Frequency during motor stop), Output Current (LCD)	Cmd. freq	0 to FU1-30[Hz]	0 [Hz]	O	6-1	
DRV-01	9101	Acceleration Time	5.5~90kW (7.5~125HP) 110~450kW (150~600HP)	Acc. Time	0 to 6000 [sec]	20 [sec]	O	6-3
						60 [sec]		
DRV-02	9102	Deceleration Time	5.5~90kW (7.5~125HP) 110~450kW (150~600HP)	Dec. time	0 to 6000 [sec]	30 [sec]	O	6-3
						90 [sec]		
DRV-03	9103	Drive Mode (Run/Stop Method)	Drive mode	0 (Keypad) 1 (Fx/Rx-1) 2 (Fx/Rx-2) 3 (Int. 485)	1 (Fx/Rx-1)	X	6-4	
DRV-04	9104	Frequency Mode (Frequency setting method)	Freq mode	0 (Keypad-1) 1 (Keypad-2) 2 (V1) 3 (V1S) 4 (I) 5 (V1+I) 6 (Pulse) 7 (Int. 485) 8 (Ext. PID)	0 (Keypad-1)	X	6-4	
DRV-05	9105	Step Frequency 1	Step freq-1	0 to FU1-30[Hz]	10 [Hz]	O	6-5	
DRV-06	9106	Step Frequency 2	Step freq-2		20 [Hz]	O		
DRV-07	9107	Step Frequency 3	Step freq-3		30 [Hz]	O		
DRV-08	9108	Output Current	Current	* [A]	* [A]	*	6-5	
DRV-09	9109	Motor Speed	Speed	* [rpm]	* [rpm]	*	6-5	
DRV-10	910A	DC link Voltage	DC link Vtg	* [V]	* [V]	*	6-6	
DRV-11	910B	User Display Selection	User disp		Output voltage [V]	*	6-6	
DRV-12	910C	Current Trip Display	Fault	*	*	*	6-6	
DRV-13	910D	Motor Direction	Use Only 7-Segment Keypad	0 (Forward) / 1 (reverse)	0	O	6-7	
DRV-14 (2)	910E	Target/Output Frequency Display	Tar. Out. Freq.	* [Hz]	* [Hz]	*	6-7	
DRV-15 (2)	910F	Reference/Feedback Frequency Display	Ref. Fbk. Freq.	* [Hz]	* [Hz]	*	6-7	
DRV-16	9110	Speed Unit Selection	Hz/Rpm Disp	Hz or Rpm	Hz	O	6-8	
DRV-18 (2)	9112	PID Parameter	PidParameter	* [Hz]	* [Hz]	X	6-8	
DRV-19	9113	AD Parameter	AD Parameter	AD	AD	X	6-8	
DRV-20 (3)	9114	EXT-PID Parameter	Ext Pid Para	%	%	X	6-9	
DRV-91 (4)	915B	Drive mode 2	Drive mode2	0 (Keypad) 1 (Fx/Rx-1) 2 (Fx//Rx-2)	1 (Fx/Rx-1)	X	6-42	
DRV-92	915C	Frequency mode 2	Freq mode2	0 (Keypad-1) 1 (Keypad-2) 2 (V1) 3 (V1S) 4 (I) 5 (V1+I) 6 (Pulse)	0 (Keypad-1)	X	6-42	

Chapter 5 – Parameter List

CODE	Comm. Addr	Description	LCD Keypad Display	Setting Range	Factory Default	Adj. During Run	Page
<p>* The gray-highlighted codes are hidden parameters and will appear when the related functions are to be set.</p> <p>(1) The speed unit is changed from [Hz] to [%] when DRV-16 is set to [Rpm]. Only User Unit will be displayed when APP-02 is set to [Yes] and when APP-06 is set to either I, V1 or Pulse and when one of I/O-86~ I/O-88 is set to either [Speed], [Percent], [Bar], [mBar], [kPa] or [Pa].</p> <p>Output Frequency is displayed in DRV-00 during the Inverter is running.</p> <p>User Unit reference is displayed in DRV-00 during the Inverter is not running.</p> <p>(2) DRV-15, DRV-18 will appear when APP-02 [Process PI Mode] is set to “Yes”. Also User Unit is displayed when one of I/O-86~ I/O-88 is set to either [Speed], [Percent], [Bar], [mBar], [kPa] or [Pa].</p> <p>(3) DRV-20 will appear when APP-80 [ExtProcess PI Mode] is set to “Yes”.</p> <p>(4) DRV-91/92 will appear only when one of I/O-20~27 is set to [Main drv] and DRV-03/04 is set to [int485].</p>							

[FU1 GROUP]

CODE	Comm. Addr	Description	LCD Keypad Display	Setting Range	Factory Default	Adj. During Run	Page	
FU1-00	9200	Jump to Desired Code #	Jump code	1 to 74 (Use Only LCD Keypad)	1	O	6-10	
FU1-01	9201	Run Prevention	Run prevention	0	(None)	0 (None)	X	6-10
				1	(Fwd prev)			
				2	(Rev prev)			
FU1-02	9202	Acceleration Pattern	Acc. Pattern	0	(Linear)	0 (Linear)	X	6-10
				1	(S-curve)			
				2	(U-curve)			
FU1-03	9203	Deceleration Pattern	Dec. Pattern	0	(Linear)	0 (Linear)	X	6-10
				1	(S-curve)			
				2	(U-curve)			
FU1-04 (5)	9204	Start Curve for S-Curve Accel/Decel Pattern	Start Curve	0 to 100 [%]	50 [%]	X	6-10	
FU1-05	9205	End Curve for S-Curve Accel/Decel Pattern	End Curve	0 to 100 [%]	50 [%]	X		
FU1-10	920A	Pre-Heat	Pre-Heat mode	0	(No)	0 (No)	X	6-11
				1	(Yes)			
FU1-11	920B	Pre-Heat Value	Pre Heat level	1 to 50 [%]	30 (%)	X	6-11	
FU1-12	920C	Pre-Heat Duty	Pre Heat Perc	1 to 100 [%]	100 (%)	X		
FU1-20	9214	Start Mode	Start mode	0	(Accel)	0 (Accel)	X	6-12
				1	(Dc-start)			
				2	(Flying-start)			
FU1-21 (6)	9115	Starting DC Injection Braking Time	DcSt time	0 to 60 [sec]	0 [sec]	X	6-12	
FU1-22	9116	Starting DC Injection Braking Value	DcSt value	0 to 150 [%]	50 [%]	X		
FU1-23	9217	Stop Mode	Stop mode	0	(Decel)	0 (Decel)	X	6-13
				1	(Dc-brake)			
				2	(Free-run)			
				3	(Flux-brake)			
FU1-24 (7)	9218	DC Injection Braking On-delay Time	DcBlk time	0.1 to 60 [sec]	0.1 [sec]	X	6-14	
FU1-25	9219	DC Injection Braking Frequency	DcBr freq	0.1 to 60 [Hz]	5 [Hz]	X		
FU1-26	921A	DC Injection Braking Time	DcBr time	0 to 60 [sec]	1 [sec]	X		
FU1-27	921B	DC Injection Braking Value	DcBr value	0 to 200 [%]	50 [%]	X		
FU1-28	921C	Safety Stop	Safety Stop	0	(No)	0 (No)	X	6-14
				1	(Yes)			
FU1-29	921D	Power Source Freq	Line Freq	40 to 120 [Hz]	60 [Hz]	X	6-15	
FU1-30	921E	Maximum Frequency	Max freq	40 to 120 [Hz]	60 [Hz]	X	6-15	
FU1-31	921F	Base Frequency	Base freq	30 to 120 [Hz]	60 [Hz]	X	6-15	
FU1-32	9220	Starting Frequency	Start freq	0.1 to 10 [Hz]	0.5 [Hz]	X	6-15	
FU1-33	9221	Frequency Limit selection	Freq limit	0	(No)	0 (No)	X	6-16
				1	(Yes)			

Chapter 5 – Parameter List

CODE	Comm. Addr	Description	LCD Keypad Display	Setting Range	Factory Default	Adj. During Run	Page	
FU1-34 (8)	9222	Low Limit Frequency	F-limit Lo	FU1-32 to FU1-35	0.5 [Hz]	O	6-16	
FU1-35	9223	High Limit Frequency	F-limit Hi	FU1-34 to FU1-30	60 [Hz]	X		
FU1-40	9228	Volts/Hz Pattern	V/F pattern	0	(Linear)	0 (Linear)	X	6-16
				1	(Square)			
				2	(User V/F)			
FU1-41 (9)	9229	User V/F – Frequency 1	User freq 1	0 to FU1-30	15 [Hz]	X	6-17	
FU1-42	922A	User V/F – Voltage 1	User volt 1	0 to 100 [%]	25 [%]	X		
FU1-43	922B	User V/F – Frequency 2	User freq 2	0 to FU1-30	30 [Hz]	X		
FU1-44	922C	User V/F – Voltage 2	User volt 2	0 to 100 [%]	50 [%]	X		
FU1-45	922D	User V/F – Frequency 3	User freq 3	0 to FU1-30	45 [Hz]	X		
FU1-46	922E	User V/F – Voltage 3	User volt 3	0 to 100 [%]	75 [%]	X		
FU1-47	922F	User V/F – Frequency 4	User freq 4	0 to FU1-30	60 [Hz]	X		
FU1-48	9230	User V/F – Voltage 4	User volt 4	0 to 100 [%]	100[%]	X		
FU1-49	9231	Input voltage adjustment	VAC 440.0V	73 to 115.0 [%]	100.0 [%]	X	6-17	
FU1-50	9232	Motor Rated Voltage	Motor Volt	0 to 600 [V]	0 [V]	X	6-17	
FU1-51	9233	Energy Save	Energy save	0	(None)	0 (None)	X	6-18
				1	(Manual)			
				2	(Auto)			
FU1-52 (10)	9234	Energy Save %	Manual save%	0 to 30 [%]	0 [%]	O		
FU1-54	9236	Integrating Wattmeter	KiloWattHour	M kWh	*	X	6-18	
FU1-55	9237	Inverter Temperature	Inv. Temp.	0 to 160 [degree]	*	X	6-18	
FU1-56	9238	Motor Temperature	Motor Temp.	0 to 160 [degree]	*	X	6-18	
FU1-57	9239	No Motor Selection	No Motor Sel	0	(No)	0 [No]	X	6-19
				1	(Yes)			
FU1-58	923A	Trip Current Level	No Motor Level	5 to 100 [%]	5 [%]	X	6-19	
FU1-59	923B	Trip Time Setting	No Motor Time	0.5 to 10.0 [sec]	3.0 [sec]	X	6-19	
FU1-60	923C	Electronic Thermal Selection	ETH select	0	(No)	1 (Yes)	O	6-19
				1	(Yes)			
FU1-61	923D	Electronic Thermal Level for 1 Minute	ETH 1min	FU1-62 to 200 [%]	150 [%]	O	6-19	
FU1-62	923E	Electronic Thermal Level for Continuous	ETH cont	50 to FU1-61 (Maximum 150%)	120 [%]	O	6-19	
FU1-63	923F	Characteristic Selection (Motor Type)	Motor type	0 (Self-cool) 1 (Forced-cool)	0 (Self-cool)	O	6-19	
FU1-64	9240	Overload Warning Level	OL level	30 to 110 [%]	110 [%]	O	6-20	
FU1-65	9241	Overload Warning Time	OL time	0 to 30 [sec]	10 [sec]	O	6-20	
FU1-66	9242	Overload Trip Selection	OLT select	0	(No)	0 (No)	O	6-21
				1	(Yes)			
FU1-67 (11)	9243	Overload Trip Level	OLT level	30 to 150 [%]	120[%]	O	6-21	
FU1-68	9244	Overload Trip Delay Time	OLT time	0 to 60 [sec]	60 [sec]	O	6-21	
FU1-69	9245	Input/Output Phase Loss Protection	Trip select	000 to 111 (Bit Set)	100	O	6-21	
FU1-70	9246	Stall Prevention Mode Selection	Stall prev.	000 to 111(Bit)	000(Bit)	X	6-21	
FU1-71	9247	Stall Prevention Level	Stall level	5.5~280kW	30 to 150 [%]	100[%]	X	6-21
				315~450kW	30 to 120 [%]			
FU1-72	9248	Accel/Decel Change Frequency	Acc/Dec ch F	0 to FU1-30	0 [Hz]	X	6-22	
FU1-73	9249	Reference Frequency for Accel and Decel	Acc/Dec freq	0	(Max freq)	0 (Max freq)	X	6-23
				1	(Delta freq)			

CODE	Comm. Addr	Description	LCD Keypad Display	Setting Range		Factory Default	Adj. During Run	Page
FU1-74	924A	Accel/Decel Time Scale	Time scale	0	(0.01 sec)	1 (0.1 sec)	O	6-23
				1	(0.1 sec)			
				2	(1 sec)			
FU1-90 (31)	925A	Safety STOP Inertia Rate	STOP Inertia	1 to 9999		10	X	6-23

* The gray-highlighted codes are hidden parameters and will appear when the related functions are to be set.

- (5) Only displayed when FU1-02, FU1-03 is set to [S-Curve].
- (6) Only displayed when FU1-20 is set to [DC-start].
- (7) Only displayed when FU1-23 is set to [DC-break].
- (8) Only displayed when FU1-33 is set to [Yes].
- (9) FU1-41~48 Only displayed when FU1-40 is set to [User V/F].
- (10) Only displayed when FU1-51 is set to [Manual].
- (11) Only displayed when FU1-66 is set to [Yes].
- (31) Only displayed when FUN-28 is set to [Yes].

Chapter 5 – Parameter List

[FU2 GROUP]

CODE	Comm. Addr	Description	LCD Keypad Display	Setting Range	Factory Default	Adj. During Run	Page	
FU2-00	9300	Jump to desired code #	Jump code	1 to 95 (Use Only LCD Keypad)	40	O	6-24	
FU2-01	9301	Last trip 1	Last trip-1	By pressing [PROG] and [▲] key, the frequency, current, and operational status at the time of fault can be seen.	0 (None)	*	6-24	
FU2-02	9302	Last trip 2	Last trip-2		0 (None)	*	6-24	
FU2-03	9303	Last trip 3	Last trip-3		0 (None)	*	6-24	
FU2-04	9304	Last trip 4	Last trip-4		0 (None)	*	6-24	
FU2-05	9305	Last trip 5	Last trip-5		0 (None)	*	6-24	
FU2-06	9306	Erase trips	Erase trips	0	(No)	0 (No)	O	6-24
				1	(Yes)			
FU2-07	9307	Dwell Frequency	Dwell time	0 to 10 [sec]	0 [sec]	X	6-24	
FU2-08 (12)	9308	Dwell Frequency	Dwell freq	FU1-32 to FU1-30	5 [Hz]	X	6-24	
FU2-10	930A	Frequency Jump Selection	Jump freq	0	(No)	0 (No)	X	6-25
				1	(Yes)			
FU2-11 (13)	930B	Jump Frequency 1 Low	jump lo 1	0 to FU2-12	10 [Hz]	O	6-25	
FU2-12	930C	Jump Frequency 1 High	jump Hi 1	FU2-11 to FU1-30	15 [Hz]	O		
FU2-13	930D	Jump Frequency 2 Low	jump lo 2	0 to FU2-14	20 [Hz]	O		
FU2-14	930E	Jump Frequency 2 High	jump Hi 2	FU2-13 to FU1-30	25 [Hz]	O		
FU2-15	930F	Jump Frequency 3 Low	jump lo 3	0 to FU2-16	30 [Hz]	O		
FU2-16	9310	Jump Frequency 3 High	jump Hi 3	FU2-15 to FU1-30	35 [Hz]	O		
FU2-20	9314	Power ON Start Selection	Power-on run	0	(No)	0 (No)	O	6-25
				1	(Yes)			
FU2-21	9315	Restart after Fault Reset	RST restart	0	(No)	0 (No)	O	
				1	(Yes)			
FU2-22	9316	Speed Search Selection	Speed Search	0000 to 1111 (Bit Set)	0000	X		
FU2-23 (14)	9317	P Gain During Speed Search	SS P-gain	0 to 9999	200	O	6-27	
FU2-24	9318	I Gain During speed search	SS I-gain	0 to 9999	500	O	6-27	
FU2-25	9319	Number of Auto Retry	Retry number	0 to 10	0	O	6-28	
FU2-26 (15)	931A	Delay Time Before Auto Retry	Retry delay	0 to 60 [sec]	1 [sec]	O	6-28	

Chapter 5 – Parameter List

CODE	Comm. Addr	Description	LCD Keypad Display	Setting Range	Factory Default	Adj. During Run	Page	
FU2-40	9328	Rated Motor Selection for 5.5 ~ 450kW Inverter	Motor select	0 (0.75kW) 1 (1.5kW) 2 (2.2kW) 3 (3.7kW) 4 (5.5kW) 5 (7.5kW) 6 (11.0kW) 7 (15.0kW) 8 (18.5kW) 9 (22.0kW) 10 (30.0kW) 11 (37.0kW) 12 (45.0kW) 13 (55.0kW) 14 (75.0kW) 15 (90.0kW) 16 (110.0kW) 17 (132.0 kW) 18 (160.0 kW) 18 (220.0 kW) 20 (280.0 kW) 21 (315.0 kW) 22 (375.0 kW) 23 (450.0 kW)	* Depending on the inverter capacity	X	6-28	
* A motor rating same as inverter capacity is automatically set. If different, set the correct value.								
FU2-41	9329	Number of Motor Poles	Pole number	2 to 12	4	X	6-28	
FU2-42	932A	Rated Motor Slip	Rated-Slip	0 to 10 [Hz]		X	6-28	
FU2-43	932B	Rated Motor Current (RMS)	Rated-Curr	1 to 999.9 [A]	* Depending on FU2-40	X		
FU2-44	932C	No Load Motor Current (RMS)	Noload-Curr	0.5 to 999.9 [A]		X		
FU2-45	932D	Motor Efficiency	Efficiency	70 to 100 [%]		X		
FU2-46	932E	Load Inertia	Inertia rate	0 to 8	0	X		
FU2-47	932F	Gain for Motor Speed Display	RPM factor	1 to 1000 [%]	100 [%]	O		
FU2-48	9330	Carrier Frequency	Carrier freq	5.5~22kW 30kW 37~75kW 90~280kW 315~450kW	0.7~15 [kHz] 0.7~ 10 [kHz] 0.7 ~ 4 [kHz] 0.7 ~ 3 [kHz] 0.7 ~ 2 [kHz]	5.0 [kHz] 4.0 [kHz] 3.0 [kHz] 2.0 [kHz]	O	6-29
FU2-49	9331	PWM Type Selection	PWM Mode	0 (Normal 1) 1 (Normal 2) 2 (Low leakage)	0 (Normal 1)	X	6-30	
FU2-60	933C	Control Mode Selection	Control mode	0 (V/F) 1 (Slip compen) 2 (Sensorless)	0 (V/F)	X	6-30	
FU2-61	933D	Auto Tuning Selection	Auto tuning	0 (No) 1 (Yes)	0 (No)	X	6-32	
FU2-62	933E	Stator Resistance of Motor	Rs	0 to (depending on FU2-40) [ohm]	* Depending on FU2-40	X		

Chapter 5 – Parameter List

CODE	Comm. Addr	Description	LCD Keypad Display	Setting Range	Factory Default	Adj. During Run	Page
FU2-63	933F	Leakage Inductance of Motor	Lsigma	0 to (depending on FU2-40) [mH]	* Depending on FU2-40	X	6-32
* Automatically set corresponding to motor rating. If different, check the motor rating setting.							
FU2-64 (16)	9340	Pre-excitation Time	PreEx time	0 to 60 [sec]	1 [sec]	X	6-32
FU2-65	9341	P Gain for Sensorless Control	SL P-gain	0 to 9999	1000	O	6-33
FU2-66	9342	I Gain for Sensorless Control	SL I-gain	0 to 9999	100	O	6-33
FU2-67	9343	Manual/Auto Torque Boost Selection	Torque boost	0 (Manual) 1 (Auto)	0 (Manual)	X	6-33
FU2-68	9344	Torque Boost in Forward Direction	Fwd boost	0 to 15 [%]	2.0 [%] 1.0 [%]	X	
FU2-69	9345	Torque Boost in Reverse Direction	Rev boost	0 to 15 [%]	2.0 [%] 1.0 [%]	X	
FU2-80	9350	Power On display	PowerOn disp	0 to 12	0	O	
FU2-81	9351	User Display Selection	User disp	0 (Voltage) 1 (Watt)	0 (Voltage)	O	6-34
FU2-82	9352	Software Version	S/W Version	Ver X.XX	Ver X.XX	*	6-35
FU2-83	9353	Last Trip Time	LastTripTime	X:XX:XX:XX:XX:X		X	6-35
FU2-84	9354	Power On Time	On-time	X:XX:XX:XX:XX:X		X	
FU2-85	9355	Run-time	Run-time	X:XX:XX:XX:XX:X		X	
FU2-87	9357	Power Set	PowerSet	0.1~400 %	100	O	6-35
FU2-90	935A	Parameter Display	Para. disp	0 (Default) 1 (All Para) 2 (Diff Para)	0 (Default)	X	6-35
FU2-91	935B	Read Parameter	Para. Read	0 (No) 1 (Yes)	0 (No)	X	6-35
FU2-92	935C	Write Parameter	Para. Write	0 (No) 1 (Yes)	0 (No)	X	6-35
FU2-93	935D	Initialize Parameters	Para. init	0 (No) 1 (All Groups) 2 (DRV) 3 (FU1) 4 (FU2) 5 (I/O) 6 (EXT) 7 (COM) 8 (APP)	0 (No)	X	6-36
FU2-94	935E	Parameter Write Protection	Para. Lock	0 to 9999	0	O	6-36
FU2-95	935F	Parameter Save	Para. save	0 (No) 1 (Yes)	0 (No)	X	6-36

* The gray-highlighted codes are hidden parameters and will appear when the related functions are to be set.

(12) Only displayed when FU2-07 is set to [1~10 sec].

(13) Only displayed when FU2-10 is set to [Yes].

(14) Only FU2-23~24 displayed when FU2-22 [Speed search] is set to [0001~1111]. Also displayed when FU1-20 is 'Flying Start'.

(15) Only displayed when FU2-25 [Retry number] is set to [1~10].

(16) Only FU2-64~66 displayed when FU2-60 is set to [Sensorless].

I/O GROUP

CODE	Comm. Addr	Description	LCD Keypad Display	Setting Range	Factory Default	Adj. During Run	Page
I/O-00	9400	Jump to desired code #	Jump code	1 to 98 (LCD Keypad Only)	1	O	6-37
I/O-01 (17)	9401	Filtering Time Constant for V1 Signal Input	V1 filter	0 to 9999 [msec]	10 [msec]	O	6-37
I/O-02	9402	V1 Input Minimum Voltage	V1 volt x1	0 to 12[V]	0 [V]	O	
I/O-03	9403	Frequency Corresponding to V1 Input Minimum Voltage	V1 freq y1	0 to FU1-30 [Hz] 0 to 100.00 [**](18)	0 [Hz]	O	
I/O-04	9404	V1 Input Minimum Voltage	V1 volt x2	0 to 12[V]	10 [V]	O	
I/O-05	9405	V1 Input Maximum Voltage	V1 freq y2	0 to FU1-30 [Hz] 0 to 100.00 [**](18)	60 [Hz]	O	
I/O-06	9406	Filtering Time Constant for I Signal Input	I filter	0 to 9999 [msec]	10 [msec]	O	6-38
I/O-07	9407	I Input Minimum Current	I curr x1	0 to 20 [mA]	4 [mA]	O	
I/O-08	9408	Frequency Corresponding to I Input Minimum Current	I freq y1	0 to FU1-30 [Hz] 0 to 100.00 [**](18)	0 [Hz]	O	
I/O-09	9409	Filtering Time Constant for I Signal Input	I curr x2	0 to 20 [mA]	20 [mA]	O	
I/O-10	940A	Frequency Corresponding to I Input Maximum Current	I freq y2	0 to FU1-30 [Hz] 0 to 100.00 [**](18)	60 [Hz]	O	
I/O-11	940B	Pulse input method	P pulse set	0 (A+B) 1 (A)	1 (A)	O	6-39
I/O-12	940C	Pulse input filter	P filter	0 to 9999 [msec]	10 [msec]	O	
I/O-13	940D	Pulse input Minimum frequency	P pulse x1	0 to 10 [kHz]	0 [kHz]	O	
I/O-14	940E	Frequency corresponding to I/O-13 Pulse input Maximum frequency	P freq y1	0 to FU1-30 [Hz] 0 to 100.00 [**](18)	0 [Hz]	O	
I/O-15	940F	Frequency corresponding to I/O-15	P pulse x2	0 to 100 [kHz]	10 [kHz]	O	
I/O-16	9410	Pulse input Minimum frequency	P freq y2	0 to FU1-30 [Hz] 0 to 100.00 [**](18)	60 [Hz]	O	6-40
I/O-17	9411	Criteria for Analog Input Signal Loss	Wire broken	0 (None) 1 (half of x1) 2 (below x1)	0 (None)	O	
I/O-18	9412	Operating selection at Loss of Freq. Reference	Lost command	0 (None) 1 (FreeRun) 2 (Stop)	0 (None)	O	
I/O-19	9413	Waiting Time after Loss of Freq. Reference	Time out	0.1 to 120 [sec]	1.0 [sec]	O	

Chapter 5 – Parameter List

CODE	Comm. Addr	Description	LCD Keypad Display	Setting Range	Factory Default	Adj. During Run	Page
I/O-20	9414	Programmable Digital Input Terminal 'M1' Define	M1 define	0 (Speed-L) 1 (Speed-M) 2 (Speed-H) 3 (XCEL-L) 4 (XCEL-M) 5 (XCEL-H) 6 (Dc-brake) 7 (2nd Func) 8 (Exchange) 9 (- Reserved -) 10 (Up) 11 (Down) 12 (3-Wire) 13 (Ext Trip) 14 (Pre-Heat) 15 (iTerm Clear) 16 (Open-loop) 17 (LOC/REM) 18 (Analog hold) 19 (XCEL stop) 20 (P Gain2) 21 (- Reserved -) 22 (Interlock1) 23 (Interlock2) 24 (Interlock3) 25 (Interlock4) 26 (Speed_X) 27 (RST) 28 (BX) 29 (JOG) 30 (FX) 31 (RX) 32 (ANA_CHG) 33 (Pre-Excite) 34 (Ext PID Run)	0 (Speed-L)	O	6-41
I/O-21	9415	Programmable Digital Input Terminal 'M2' Define	M2 define	Same as I/O-20	1 (Speed-M)	O	
I/O-22	9416	Programmable Digital Input Terminal 'M3' Define	M3 define	Same as I/O-20	2 (Speed-H)	O	
I/O-23	9417	Programmable Digital Input Terminal 'M4' Define	M4 define	Same as I/O-20	27 (RST)	O	
I/O-24	9418	Programmable Digital Input Terminal 'M5' Define	M5 define	Same as I/O-20	28 (BX)	O	
I/O-25	9419	Programmable Digital Input Terminal 'M6' Define	M6 define	Same as I/O-20	29 (JOG)	O	

CODE	Comm. Addr	Description	LCD Keypad Display	Setting Range	Factory Default	Adj. During Run	Page	
I/O-26	941A	Programmable Digital Input Terminal 'M7' Define	M7 define	Same as I/O-20	30 (FX)	O	6-41	
I/O-27	941B	Programmable Digital Input Terminal 'M8' Define	M8 define	Same as I/O-20	31 (RX)	O		
I/O-28	941C	Terminal Input Status	In status	0000000000 /1111111111	0000000000	*		
I/O-29	941D	Filtering Time Constant for Programmable Digital Input Terminals	Ti Filt Num	2 to 1000 [msec]	15	O		
I/O-30 (19)	941E	Jog Frequency Setting	Jog freq	0 to FU1-30	10 [Hz]	O	6-42	
I/O-31	941F	Step Frequency 4	Step freq-4		40 [Hz]	O		
I/O-32	9420	Step Frequency 5	Step freq-5		50 [Hz]	O		
I/O-33	9421	Step Frequency 6	Step freq-6		40 [Hz]	O		
I/O-34	9422	Step Frequency 7	Step freq-7		30 [Hz]	O		
I/O-35	9423	Step Frequency 8	Step freq-8		20 [Hz]	O		
I/O-36	9424	Step Frequency 9	Step freq-9		10 [Hz]	O		
I/O-37	9425	Step Frequency 10	Step freq-10		20 [Hz]	O		
I/O-38	9426	Step Frequency 11	Step freq-11		30 [Hz]	O		
I/O-39	9427	Step Frequency 12	Step freq-12		40 [Hz]	O		
I/O-40	9428	Step Frequency 13	Step freq-13		50 [Hz]	O		
I/O-41	9429	Step Frequency 14	Step freq-14		40 [Hz]	O		
I/O-42	942A	Step Frequency 15	Step freq-15		30 [Hz]	O		
I/O-50	9432	Acceleration Time 1 (for Step speed)	Acc time-1	0 to 6000 [sec]	20 [sec]	O	6-44	
I/O-51	9433	Deceleration Time 1 (for Step speed)	Dec time-1	0 to 6000 [sec]	20 [sec]	O		
I/O-52 (20)	9434	Acceleration Time 1 (for Step speed)	Acc time-2	0 to 6000 [sec]	30 [sec]	O		
I/O-53	9435	Deceleration Time 2	Dec time-2	0 to 6000 [sec]	30 [sec]	O		
I/O-54	9436	Acceleration Time 3	Acc time-3	0 to 6000 [sec]	40 [sec]	O		
I/O-55	9437	Deceleration Time 3	Dec time-3	0 to 6000 [sec]	40 [sec]	O		
I/O-56	9438	Acceleration Time 4	Acc time-4	0 to 6000 [sec]	50 [sec]	O		
I/O-57	9439	Deceleration Time 4	Dec time-4	0 to 6000 [sec]	50 [sec]	O		
I/O-58	943A	Acceleration Time 5	Acc time-5	0 to 6000 [sec]	40 [sec]	O		
I/O-59	943B	Deceleration Time 5	Dec time-5	0 to 6000 [sec]	40 [sec]	O		
I/O-60	943C	Acceleration Time 6	Acc time-6	0 to 6000 [sec]	30 [sec]	O		
I/O-61	943D	Deceleration Time 6	Dec time-6	0 to 6000 [sec]	30 [sec]	O		
I/O-62	943E	Acceleration Time 7	Acc time-7	0 to 6000 [sec]	20 [sec]	O		
I/O-63	943F	Deceleration Time 7	Dec time-7	0 to 6000 [sec]	20 [sec]	O		
I/O-70	9446	S0 output selection	S0 mode	0	(Frequency)	0 (Frequency)	O	6-47
				1	(Current)			
				2	(Voltage)			
				3	(DC link Vtg)			
				4	(Ext PID Out)			

Chapter 5 – Parameter List

CODE	Comm. Addr	Description	LCD Keypad Display	Setting Range	Factory Default	Adj. During Run	Page
I/O-71	9447	S0 output adjustment	S0 adjust	10 to 200 [%]	100 [%]	O	6-47
I/O-72	9448	S1 output selection	S1 mode	Same as I/O-70	2 (Voltage)	O	
I/O-73	9449	S1 output adjustment	S1 adjust	10 to 200 [%]	100 [%]	O	
I/O-74 (21)	944A	Frequency Detection Level	FDT freq	0 to FU1-30 [Hz]	30 [Hz]	O	6-47
I/O-75	944B	Frequency Detection Bandwidth	FDT band	0 to FU1-30 [Hz]	10 [Hz]	O	6-47
I/O-76	944C	Programmable Digital Output Terminal Define (Aux terminal)	Aux mode1	0 (NONE) 1 (FDT-1) 2 (FDT-2) 3 (FDT-3) 4 (FDT-4) 5 (FDT-5) 6 (OL) 7 (IOL) 8 (Stall) 9 (OV) 10 (LV) 11 (OH) 12 (Lost Command) 13 (Run) 14 (Stop) 15 (Steady) 16 (INV line) 17 (COMM line) 18 (SSearch) 19 (Ready) 20 (MMC)	0 (NONE)	O	6-48
I/O-77	944D	Programmable Digital Output Terminal Define	Aux mode2	Same as I/O-76	0 (NONE)	O	
I/O-78	944E	Programmable Digital Output Terminal Define	Aux mode3	Same as I/O-76	0 (NONE)	O	
I/O-79	944F	Programmable Digital Output Terminal Define	Aux mode4	Same as I/O-76	0 (NONE)	O	
I/O-80	9450	Fault Output Relay Setting (3A, 3B, 3C)	Relay mode	000 to 111 [bit]	010 [bit]	O	
I/O-81	9451	Terminal Output Status	Out status	00000000/11111111	00000000	*	6-52
I/O-82	9452	Waiting time after Fault Output Relay On	Relay On	0 to 9999	0	X	6-52
I/O-83	9453	Waiting time after Fault Output Relay Off	Relay Off	0 to 9999	0	X	
I/O-84	9454	Fan Con Sel (37 ~ 90kW)	Fan Mode	0 (Power On Fan)	0	X	6-52

CODE	Comm. Addr	Description	LCD Keypad Display	Setting Range	Factory Default	Adj. During Run	Page
I/O-84	9454	Fan Con Sel (37 ~ 90kW)	Fan Mode	1 (Run Fan)	0	X	6-52
				2 (Temper-Fan)			
I/O-85	9455	Fan Temp (37 ~ 90kW)	Fan Temper	0 to 70 [°C]	70 [°C]	O	6-52
I/O-86	9456	Voltage Input User Unit Selection	V1 Unit Sel	0 (Speed) 1 (Percent) 2 (Bar) 3 (mBar) 4 (kPa) 5 (Pa)	0 (Speed)	X	6-52
I/O-87	9457	Current Input User Unit Selection	I Unit Sel	Same as I/O-86	0 (Speed)	X	
I/O-88	9458	Pulse Input User Unit Selection	PulseUnitSel	Same as I/O-86	0 (Speed)	X	
I/O-90	945A	Inverter Number	Inv No.	1 to 250	1	O	6-53
I/O-91 (22)	945B	Baud Rate Selection	Baud rate	0 (1200 bps)	3 (9600 bps)	O	
				1 (2400 bps)			
				2 (4800 bps)			
				3 (9600 bps)			
				4 (19200 bps)			
5 (38400 bps)							
I/O-92 (23)	945C	Operating method at loss of freq. reference	COM Lost Cmd	0 (None)	0 (None)	O	
				1 (FreeRun)			
				2 (Stop)			
I/O-93	945D	Waiting time after loss of freq. reference	COM Time Out	0.1 to 120 [sec]	1.0 [sec]	O	
I/O-94	945E	Communication Response Delay time	Delay Time	2 to 1000 [msec]	5 [msec]	O	6-53
I/O-95	945F	A or B contact	In No/Nc Set	0000000000 /1111111111	0000000000	X	6-53
I/O-96	9460	Input time	In CheckTime	1 to 1000	1 [msec]	X	6-54
I/O-97	9461	Overheat trip selection	OH Trip sel	000 to 111 [bit]	010 [bit]	X	6-54
I/O-98	9462	Motor overheat trip temperature	MO Trip Temp	0 to 255 [8C]	110 [8C]	X	

* The gray-highlighted codes are hidden parameters and will appear when the related functions are to be set.

(17) When DRV-04 is set to either V1, V1S, I or V1+I or Pulse, only selected item codes are displayed in I/O-1~I/O-19.

(18) Only user unit displayed when APP-02 or APP-80 is set to [Yes], after APP-06 is set to one of I, V, Pulse, after then one of I/O-86 ~I/O-88 is set to either speed, percentage, Bar, mBar, kPa, Pa..

(19) I/O-30 ~ I/O-34 displayed only when one of I/O-20 ~ I/O-27 is set to either JOG, Speed_L, Speed_M, Speed_H. I/O-35 ~ I/O-42 displayed only when one of I/O-20 ~ I/O-27 is set to Speed_X.

(20) I/O-52 ~ I/O-63 displayed only when one of I/O-20 ~ I/O-27 is set to either XCEL_L, XCEL_M, XCEL_H.

(21) I/O-74 ~ I/O-75 displayed only when one of I/O-76 ~ I/O-79 is set to either FDT-1~FDT5

(22) 38400 bps can be set only when the external communication option card is installed.

(23) Only I/O-92 ~ I/O-93 displayed when DRV-03/04 is set to [int485].

Chapter 5 – Parameter List

[APP GROUP]

CODE	Comm. Addr	Description	LCD Keypad Display	Setting Range	Factory Default	Adj. During Run	Page
APP-00	9700	Jump to Desired Code #	Jump code	1 to 99 (LCD Keypad Only)	1	O	6-56
APP-01 (24)	9701	Application Mode Selection	App mode	0 (None) 1 (MMC)	0 (None)	X	6-56
APP-02	9702	PID Operation Selection	Proc PI mode	0 (No) 1 (Yes)	0 (No)	X	6-56
APP-03 (25)	9703	PID F Gain Selection	PID F-gain	0 to 999.9[%]	0.0 [%]	O	6-61
APP-04 (256)	9704	PID Auxiliary Reference Mode Selection	Aux Ref Mode	0 (No) 1 (Yes)	0 (No)	X	6-61
APP-05 (27)	9705	PID Auxiliary Reference Signal Selection	Aux Ref Sel	0 (Keypad-1) 1 (Keypad-2) 2 (V1) 3 (V1S) 4 (I) 5 (V1+I) 6 (Pulse) 7 (Int. 485) 8 (Ext. PID)	2 (V1)	X	6-61
APP-06	9706	PID Feedback Signal Selection	PID F/B	0 (I) 1 (V1) 2 (Pulse)	0 (I)	X	6-61
APP-07	9707	P Gain for PID Control	PID P-gain	0 to 999.9 [%]	1.0 [%]	O	6-61
APP-08	9708	I Gain for PID Control	PID I-time	0 to 32.0 [sec]	10.0 [sec]	O	6-61
APP-09	9709	D Gain for PID Control	PID D-time	0 to 100 [msec]	0.0 [msec]	O	6-61
APP-10	970A	High Limit Frequency for PID Control	PID limit-H	0.00 to FU1-30	60 .00[Hz]	O	6-61
APP-11	970B	Low Limit Frequency for PID Control	PID limit-L	FU1-32 to APP-10	0.5 [Hz]	O	6-61
APP-12	970C	PID Output Scale	PID Out Scale	0.0 to 999.9 [%]	100.0 [%]	X	6-62
APP-13	970D	PID P2 Gain	PID P2-gain	0.0 to 999.9 [%]	100.0 [%]	X	6-62
APP-14	970E	P Gain Scale	P-gain Scale	0.0 to 100.0 [%]	100.0 [%]	X	6-62
APP-15	960F	PID Output Inverse	Out inverse	0 (No) 1 (Yes)	0 (No)	X	
APP-17	9711	PID U curve feedback select	PID U Fbk	0 (No) 1 (Yes)	0 (No)	X	
APP-20 (28)	9714	2nd Acceleration Time	2nd Acc time	0 to 6000 [sec]	5 [sec]	O	6-62
APP-21	9715	2nd Deceleration Time	2nd Dec time	0 to 6000 [sec]	10 [sec]	O	
APP-22	9716	2nd Base Frequency	2nd BaseFreq	30 to FU1-30 [Hz]	60 [Hz]	X	
APP-23	9717	2nd V/F Pattern	2nd V/F	0 (Linear) 1 (Square) 2 (User V/F)	0 (Linear)	X	
APP-24	9718	2nd Forward Torque Boost	2nd F-boost	0 to 15 [%]	2 [%]	X	
APP-25	9719	2nd Reverse Torque Boost	2nd R-boost	0 to 15 [%]	2 [%]	X	
APP-26	971A	2nd Stall Prevention Level	2nd Stall	30 to 150 [%]	100 [%]	X	

CODE	Comm. Addr	Description	LCD Keypad Display	Setting Range	Factory Default	Adj. During Run	Page
APP-27	971B	2nd Electronic Thermal Level for 1 minute	2nd ETH 1min	FU2-28 to 200 [%]	130[%]	O	6-62
APP-28	971C	2nd Electronic Thermal Level for continuous	2nd ETH cont	50 to FU2-27 (Max 150%)	120[%]	O	
APP-29	971D	2nd Rated Motor Current	2nd R-Curr	1 to 200 [A]	3.6[A]	X	
APP-40 (29)	9728	Number of Auxiliary Motor Run Display	Aux Mot Run	*	*	*	6-63
APP-41	9729	Aux. Motor Start Selection	Starting Aux	1 to 4	1	O	6-64
APP-42	972A	Operation Time Display on Auto Change	Auto Op Time	*	*	*	6-64
APP-43	972B	The Number of Aux Motor	Nbr Aux's	0 to 7	4	O	6-64
APP-44	972C	Start Frequency of Aux. Motor 1	Start freq 1	0 to FU1-30	49.99 [Hz]	O	6-64
APP-45	972D	Start Frequency of Aux. Motor 2	Start freq 2		49.99 [Hz]	O	
APP-46	972E	Start Frequency of Aux. Motor 3	Start freq 3		49.99 [Hz]	O	
APP-47	972F	Start Frequency of Aux. Motor 4	Start freq 4		49.99 [Hz]	O	
APP-48	9730	Start Frequency of Aux. Motor 5	Start freq 5		49.99 [Hz]	O	
APP-49	9731	Start Frequency of Aux. Motor 6	Start freq 6		49.99 [Hz]	O	
APP-50	9732	Start Frequency of Aux. Motor 7	Start freq 7		49.99 [Hz]	O	
APP-51	9733	Stop Frequency of Aux. Motor 1	Stop freq 1		0 to FU1-30	20.00 [Hz]	
APP-52	9734	Stop Frequency of Aux. Motor 2	Stop freq 2	20.00 [Hz]		O	
APP-53	9735	Stop Frequency of Aux. Motor 3	Stop freq 3	20.00 [Hz]		O	
APP-54	9736	Stop Frequency of Aux. Motor 4	Stop freq 4	20.00 [Hz]		O	
APP-55	9737	Stop Frequency of Aux. Motor 5	Stop freq 5	15.00 [Hz]		O	
APP-56	9738	Stop Frequency of Aux. Motor 6	Stop freq 6	15.00 [Hz]		O	
APP-57	9739	Stop Frequency of Aux. Motor 7	Stop freq 7	15.00 [Hz]		O	
APP-58	973A	Delay Time before Operating Aux Motor	Aux start DT	0.0 to 999.9 [sec]		5.0 [sec]	O
APP-59	973B	Delay Time before Stopping Aux Motor	Aux stop DT	0.0 to 999.9 [sec]	5.0 [sec]	O	6-65
APP-60	973C	Accel time when the number of pump decreases	Pid AccTime	0 to 600.0 [sec]	2.0 [sec]	O	6-65

Chapter 5 – Parameter List

CODE	Comm. Addr	Description	LCD Keypad Display	Setting Range	Factory Default	Adj. During Run	Page
APP-61	973D	Decel time when the number of pump increases	Pid DecTime	0 to 600.0 [sec]	2.0 [sec]	O	6-65
APP-62	973E	PID Bypass Selection	Regul Bypass	0 (No) 1 (Yes)	0 (No)	X	6-65
APP-63	973F	Sleep Delay Time	Sleep Delay	0.0 to 9999 [sec]	60.0 [sec]	O	6-66
APP-64	9740	Sleep Frequency	Sleep Freq	0 to FU1-30 [Hz]	0.00 [Hz]	O	6-66
APP-65	9741	Wake-Up Level	WakeUp level	0.0 to 100.0 [%]	2.0[%]	O	6-66
APP-66	9742	Auto Change Mode Selection	AutoCh_Mode	0, 1 (Aux), 2 (Main)	0	O	6-67
APP-67	9743	Auto Change Time	AutoEx-intv	00:00 to 99:00	72:00	O	6-67
APP-68	9744	Auto Change Level	AutoEx-level	FU1-32 to FU1-30 [Hz]	20.0 [Hz]	O	6-67
APP-69	9745	Inter-Lock Selection	Inter-lock	0 (No) 1 (Yes)	0 (No)	O	6-68
APP-71	9747	Pressure difference for Aux motor Stop	Actual Pr Diff	0 to 100%	2%	O	6-70
APP-74	974A	PrePID Reference Frequency	PrePID freq	0 to FU1-30	0.00 [Hz]	O	6-70
APP-75	974B	PrePID Exit Level	PrePID Exit	0 to 100.0%	0.0 [%]	O	
APP-76	974C	PrePID Stop delay	PrePID dly	0 to 9999	600 [sec]	O	
APP-80	9750	Ext PID Operation Selection	Ext PI mode	0 (No) 1 (Yes)	0 (No)	X	6-70
APP-81 (30)	9751	Ext PID Reference Signal Selection	Ext Ref Sel	0 (I) 1 (V1) 2 (Pulse) 3 (Key-Pad)	3 (Key-Pad)	X	6-70
APP-82	9752	Ext PID Reference Level	Ext Ref Perc	0 to 100.00 [%]	50.00 [%]	X	6-70
APP-83	9753	Ext PID Feedback Signal Selection	Ext Fbk Sel	0 (I) 1 (V1) 2 (Pulse)	0 (I)	X	6-70
APP-85	9755	P Gain for ExtPID	ExtPID Pgain	0 to 999.9 [%]	1.0 [%]	X	6-70
APP-86	9756	I Time for ExtPID	ExtPID Itime	0 to 32.0 [sec]	10.0 [sec]	X	6-70
APP-87	9757	D Time for ExtPID	ExtPID Dtime	0 to 2000 [msec]	0 [msec]	X	6-70
APP-88	9758	High Limit Frequency for ExtPID Control	ExtPID lmt-H	0 to 100.00 [%]	100.00 [%]	X	6-70
APP-89	9759	Low Limit Frequency for ExtPID Control	ExtPID lmt-L	0 to 30.00 [%]	0.00 [%]	X	6-70
APP-90	975A	ExtPID Output Scale	ExtPID Scale	0 to 999.9	100.0 [%]	X	6-70
APP-91	975B	ExtPID P2 Gain	Ext P2-gain	0 to 999.9	100.0 [%]	X	6-70
APP-92	975C	ExtPID P Gain Scale	Ext P Scale	0 to 100.0	100.0 [%]	X	6-70
APP-93	975D	ExtPID F Gain	ExtPID F-gain	0 to 999.9 [%]	0.0 [%]	O	6-70

CODE	Comm. Addr	Description	LCD Keypad Display	Setting Range	Factory Default	Adj. During Run	Page
APP-95	975F	ExtPID Output Inverse	ExtOut inverse	0 (No) 1 (Yes)	0 (No)	X	6-70
APP-97	9761	ExtPID Loop Time	Ext Loop Time	50 to 200 [msec]	100 [msec]	X	6-70

* The gray-highlighted codes are hidden parameters and will appear when the related functions are to be set.

(24) MMC(Multi Motor Control) function is applied to the inverters only for 5.5~90kW(7.5~125HP).

(25) Only APP-03 ~ APP-17 displayed when APP-02 is set to [Yes]. (5.5 ~ 90kW / 7.5 ~ 125HP)

Only APP-03 ~ APP-17 and APP-63 ~ APP-65 displayed when APP-2 is set to [Yes]. (100 ~ 450kW / 150 ~ 600HP)

(26) If APP-04 is no set, DRV-04 setting will be reference of processPID. And APP -05 setting will be ignored

(27) If APP-04 is set, APP-04 will appear. And APP -05 setting value will be reference of processPID, DRV-04 setting will be ignored.

(28) Only APP-20 ~ APP-29 displayed only when one of I/O-20 ~ I/O-27 is set to either “2nd Func”.

(29) Only APP-40 ~ APP-71 displayed when APP-01 is set to [MMC].

(30) Only APP-81 ~ APP-97 displayed when APP-80 is set to [Yes].

Chapter 5 – Parameter List

[EXT GROUP]

CODE	Comm. Addr	Description	LCD Keypad Display	Setting Range	Factory Default	Adj. During Run	Page
EXT-00	9500	Jump Code	Jump code	1 to 45	1	O	Refer to the corresponding option manual
EXT-01	9501	Type of SUB Board	Sub B/D	Sub-E	*	*	
EXT-40	9528	Current Output Terminal 1(CO1) Selection	AM1 mode	Frequency Current Voltage DC link Vtg Ext PID Out	Frequency	O	
EXT-41	9529	Adjust Gain of Current Output Terminal 1(CO1)	AM1 adjust	10 – 200 [%]	100 [%]	O	
EXT-42	952A	Adjust Offset of Current Output Terminal 1(CO1)	AM1 Offset	0 – 100 [%]	0 [%]	O	
EXT-43	952B	Current Output Terminal 2(CO2) Selection	AM2 mode	Frequency Current Voltage DC link Vtg Ext PID Out	DC link Vtg	O	
EXT-44	952C	Adjust Gain of Current Output Terminal 2(CO2)	AM2 adjust	10 – 200 [%]	100 [%]	O	
EXT-45	952D	Adjust Offset of Current Output Terminal 2(CO2)	AM2 Offset	0 – 100 [%]	0 [%]	O	
* Only the above EXT group displayed when the corresponding option board is installed.							
* Refer to the SUB board option manual for details.							

[COM GROUP]

CODE	Comm. Addr	Description	LCD Keypad Display	Setting Range	Factory Default	Adj. During Run	Page
COM-00	9600	Jump Code	Jump code	1 to 60	1	O	Refer to the corresponding option manual
COM-01	9601	Type of SUB Board	Opt B/D	RS485 DeviceNet Profibus BACnet LonWork	*	*	
COM-02	9602	Option Mode	Opt mode	None Command Freq Cmd + Freq	None	X	
COM-03	9603	Option Version	Opt Version	Ver X.X	Ver X.X	*	
COM-13	960D	DeviceNet Input Instance	In Instance	(70) (71) (110) (111)	70	○	
COM-17	9611	PLC Option Station ID	Station ID	0 - 63	1	○	
COM-20	9614	Profibus ID	Profi MAC ID	1 - 127	1	○	
COM-30	961E	Output Number	Output Num	0 - 8	3	○	
COM-31	961F	Output1	Output 1	0000 – FFFF (HEX)	000A(HEX)	○	
COM-32	9620	Output2	Output 2	0000 – FFFF (HEX)	000E(HEX)	○	
COM-33	9621	Output 3	Output 3	0000 – FFFF (HEX)	000F(HEX)	○	
COM-34	9622	Output 4	Output 4	0000 – FFFF (HEX)	0000(HEX)	○	
COM-35	9623	Output 5	Output 5	0000 – FFFF (HEX)	0000(HEX)	○	
COM-36	9624	Output 6	Output 6	0000 – FFFF (HEX)	0000(HEX)	○	
COM-37	9625	Output 7	Output 7	0000 – FFFF (HEX)	0000(HEX)	○	
COM-38	9626	Output 8	Output 8	0000 – FFFF (HEX)	0000(HEX)	○	
COM-40	9628	Input Number	Input Num	0 - 8	2	○	
COM-41	9629	Input 1	Input 1	0000 – FFFF (HEX)	0005(HEX)	○	
COM-42	962A	Input 2	Input 2	0000 – FFFF (HEX)	0006(HEX)	○	
COM-43	962B	Input 3	Input 3	0000 – FFFF (HEX)	0000(HEX)	○	
COM-44	962C	Input 4	Input 4	0000 – FFFF (HEX)	0000(HEX)	○	
COM-45	962D	Input 5	Input 5	0000 – FFFF (HEX)	0000(HEX)	○	
COM-46	962E	Input 6	Input 6	0000 – FFFF (HEX)	0000(HEX)	○	
COM-47	962F	Input 7	Input 7	0000 – FFFF (HEX)	0000(HEX)	○	
COM-48	9630	Input 8	Input 8	0000 – FFFF (HEX)	0000(HEX)	○	
COM-60	963C	Parity Selection	Parity/Stop	8None/1Stop 8None/2Stop 8Even/1Stop 8 Odd/1Stop	8None/1Stop	○	
COM-61 (31)	963D	Communication Option Common Parameter 1	Opt Para-1	0000 – FFFF (HEX)	0000(HEX)	○	
COM-62	963E	Communication Option Common Parameter 2	Opt Para-2	0000 – FFFF (HEX)	0000(HEX)	○	
COM-63	963F	Communication Option Common Parameter 3	Opt Para-3	0000 – FFFF (HEX)	0000(HEX)	○	
COM-64	9640	Communication Option Common Parameter 4	Opt Para-4	0000 – FFFF (HEX)	0000(HEX)	○	
COM-65	9641	Communication Option Common Parameter 5	Opt Para-5	0000 – FFFF (HEX)	0000(HEX)	○	
COM-66	9642	Communication Option Common Parameter 6	Opt Para-6	0000 – FFFF (HEX)	0000(HEX)	○	
COM-67	9643	Communication Option Parameter Update	Comm UpDate	1 (No) 2 (Yes)	1 (No)	X	

* Only the above COM group displayed when the corresponding option board is installed.

* Refer to the communication option manual for details.

* LonWork and BACnet communication will be available later.

(31) COM-61~66 is used for LonWork and BACnet communication.

CHAPTER 6 - PARAMETER DESCRIPTION

6.1 Drive group [DRV]

DRV-00: Command Frequency/ Output Current (LCD)

DRV ▶ Cmd. Freq
00 0.00 Hz **F** **0.00**

Factory Default: 0.00 Hz **0.00**

1) Digital frequency setting

- When DRV-04 [Frequency Mode] is set to 0 (Keypad-1) or 1 (Keypad-2), command freq is settable less than FU1-30 [Maximum Frequency].

2) Monitoring function setting

- Command frequency displayed during stop.
- Output current/frequency displayed during run.
Analog/digital frequency command source setting:
DRV-04 [Frequency Mode]

When DRV-04 [Frequency Mode] is set to V1, V1S, I, V1+I or Pulse, frequency command is set via I/O-01~16 [Analog Frequency command]. Refer to I/O-01~16 for detail description.

When setting APP-02 [PID operation selection] and/or APP-80 [Ext. PID operation select] to “Yes”, I/O-86~88 parameter settings become available. Changing I/O-86~88 value will affect all of the unit display for reference values such as DRV-00 and I/O-01~16. See the related parameter description on the manual for more.

When APP-02 [PID operation selection] is set to “Yes” with APP-04 [PID Aux speed selection] to “No,” the selection made among V1, V1S, I, V1+I, Pulse in DRV-04 [Freq mode] becomes PID reference input value and PID target output value becomes inverter reference frequency. See the PID description on the manual for more. Set APP-80 [Ext. PID operation selection] to “Yes” and control terminal “I” to “4~20mA”, Ext. PID feedback value. Set one of the I/O-20~27 to [Ext PID Run]. When the selected terminal for [Ext PID Run] is turned ON, Ext. PID operation begins and Ext. PID output value becomes inverter command frequency. See APP-80~97 for details.

When DRV-16 [Speed Unit Selection] is set to 1 (Rpm), Hz display is changed to Rpm.

DRV-04 [Frequency Mode] setting guide

Set	DRV-04	Name	Programming Description
0	Key Pad-1	Digital freq. command	1. In DRV-00, press the [PROG] key. 2. Set the desired freq. 3. Press the [ENT] key to write the new value into memory.
1	Key Pad-2		1. In DRV-00, press the [PROG] key. 2. Press the [↑(Up)] or [↓(Down)] key to set the desired freq. Speed is reflected to the inverter real time upon pressing the UP/DOWN keys. 3. Press the [ENT] key to write the new value into memory.
2	V1	Analog freq. command	Voltage analog input (0 to 12V) to Control terminal “V1”. See the description of I/O-01~05.
3	V1S		Voltage analog input (-12 to 12V, FWD/REV Run) to Control terminal “V1”. See the description of I/O-01~05.
4	I		Current analog input (4 to 20mA) to Control terminal “I”. See the description of I/O-06~10.
5	V1+I		0-10V/4-20mA Analog input Control terminal “V1”, “I”. See the description of I/O-01~10.
6	Pulse		Pulse command
7	Int. 485	Communication	Set the command frequency using RS485 (1200~19200bps) from “C+ or C-” control terminals. See the I/O-90~93.
8	Ext. PID	Ext. PID Reference frequency	Set APP-80 [Ext PI Mode] to [Yes]. Apply 4~20mA {Ext. PID feedback value} to control terminal “I”. Set one of the I/O-20~27 to [Ext PID Run]. When the defined terminal is ON, inverter starts Ext. PID operation and the Ext. PID output value becomes inverter command frequency. See APP-80~97 for more.

I/O-01~05 [Frequency command setting via Analog Voltage Input "V1"]

Command Freq. setting via "V1" input terminal when set DRV-04 [Frequency mode] to V1, V1S, or V1+I. A User-selected unit will be displayed in [**] when one of the APP-02[PID operation selection] and APP-80 [Ext. PID operation selection] is set to "Yes," and set the desired unit among Percent, Bar, mBar, kPa, Pa in I/O-86 [Voltage input user unit selection].

Code	Default	Setting range
I/O-01	10 [msec]	0 ~ 9999 [msec]
I/O-02	0 [V]	0 ~ 12 [V]
I/O-03	0 [Hz]	0 ~ Max. freq
	0 [**]	0~100.00[**]
I/O-04	10 [V]	0 ~ 12 [V]
I/O-05	60 [Hz]	0 ~ Max freq
	0 [**]	0~100.00[**]

Code	LCD Display	Parameter Name
I/O-01	V1 filter	Filter Time Constant for V1 Input
I/O-02	V1 volt x1	V1 Input Minimum Voltage
I/O-03	V1 freq y1	Frequency Corresponding to V1 Input Minimum Voltage
	V1[**]y1	Target value Corresponding to V1 input minimum voltage.
I/O-04	V1 volt x2	V1 Input Maximum Voltage
I/O-05	V1 freq y2	Frequency Corresponding to V1 Input Maximum Voltage
	V1[**]y2	Target value Corresponding to V1 input maximum voltage.

Important: Increase I/O-01 [Filter Time Constant for V1 Input] if the V1 signal is affected by noise causing unstable operation. Increasing this value makes response time slower.

In the case of 0~12V V1 voltage input

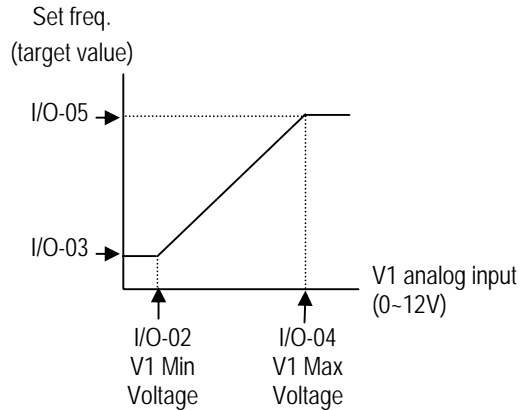

In the case of -12~12V V1 voltage input

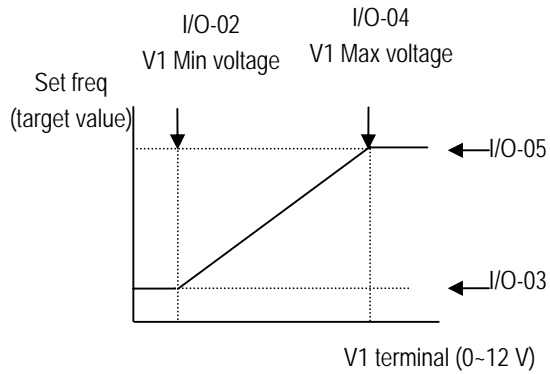

Setting for Bi-polarity and the uni-polarity is the same as the graph above. Set the positive value for Voltage and frequency and negative value is symmetrical of positive setting. The following graph shows the relationship between voltage input and direction command (Positive/Negative).

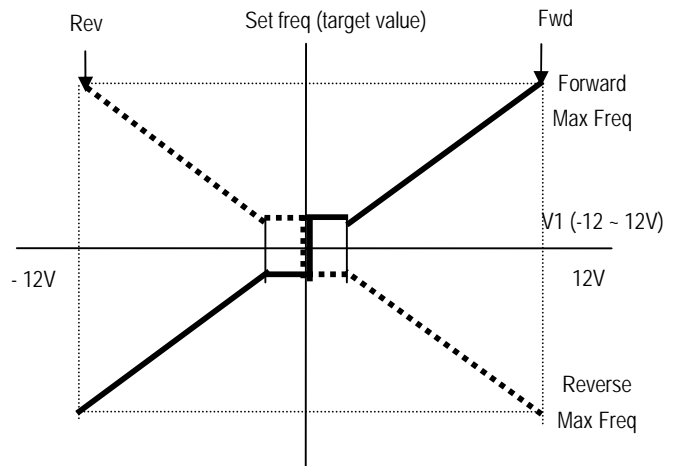

To drive the motor in Forward direction, press FWD key and apply 0-12V voltage as frequency command or press REV key and apply -12~0V voltage as frequency command. To drive the motor in Reverse direction, press FWD key and apply -12~0V or press REV key and apply 0~12V.

I/O-06~10 [Analog Current Input "I" Signal adjustment]

Command Freq setting via "I" input terminal when set DRV-04 [Frequency mode] to 3 (I) or 4 (V1+I) A User-selected unit will be displayed in [**] when one of the APP-02[PID operation selection] and APP-80 [Ext. PID operation selection] is set to "Yes," and set the desired unit among Percent, Bar, mBar, kPa, Pa in I/O-87 [Current input user unit selection].

Code	Default	Setting range
I/O-06	10 [msec]	0 ~ 9999 [msec]
I/O-07	4 [mA]	0 ~ 20 [mA]
I/O-08	0 [Hz]	0 ~ Max. freq
	0 [**]	0 ~ 100.00[**]
I/O-09	20 [mA]	0 ~ 20 [mA]
I/O-10	60 [Hz]	0 ~ Max. freq
	0 [**]	0 ~ 100.00[**]

Code	LCD display	Parameter Name
I/O06	I filter	Filter time constant for I signal Input
I/O-07	I curr x1	I Input Minimum Current
I/O-08	I freq y1	Frequency Corresponding to I Input Minimum Current
	I [**] y1	Target value Corresponding to I Input Minimum Voltage
I/O-09	I curr x2	I Input Maximum Current
I/O-1-0	I freq y2	Frequency Corresponding to I Input Maximum Current
	I [**] y2	Target value Corresponding to I Input Maximum Voltage

Important: Increase I/O-06 [Filter time constant for I signal Input] if I signal is affected by noise causing unstable operation. Increasing this value makes response time slower.

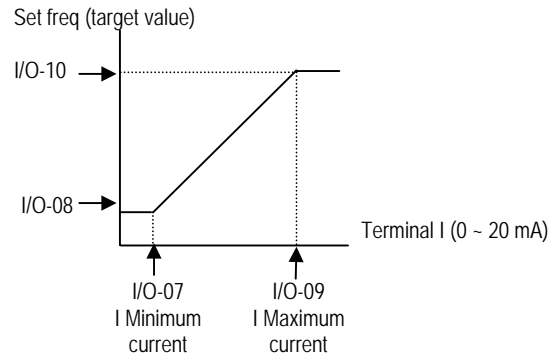

DRV-01, 02: Accel/Decel Time 0

DRV▶ Acc. time	01	20.0
01 20.0 sec		

Factory Default: 20.0 sec	20.0
---------------------------	-------------

DRV▶ Dec. time	02	30.0
02 30.0 sec		

Factory Default: 30.0 sec	30.0
---------------------------	-------------

The inverter targets FU2-73 when accelerating or decelerating. When FU2-73 is set to "Maximum Frequency", the acceleration time is the time taken by the motor to reach FU1-30 from 0 Hz. The deceleration time is the time taken by the motor to reach 0 Hz from FU1-30 [Maximum Frequency]. When FU2-73 is set to "Delta Frequency", the acceleration and deceleration time is the time taken to reach a target frequency (instead the maximum frequency) from a specific frequency. The acceleration and deceleration time can be changed to a preset time via Programmable digital inputs. By setting M1~M8 to 'XCEL-L', 'XCEL-M', 'XCEL-H' respectively, the 1~7 Accel and Decel time set in I/O-50 to I/O-63 are applied by the binary inputs of the M1~M8.

Note: Set the Accel time more than 0.5 sec for smooth acceleration. Setting it too short may deteriorate the starting performance.

In case of the inverters for 110~450kW(150~600HP), the factory default of Accel/Decel Time is 60.0/90.0[sec] respectively.

Chapter 6 - Parameter Description [DRV]

Code	LCD display	Name	XCEL -H	XCEL -M	XCEL -L	Default
DRV-01	Acc time	Acc time 0	0	0	0	20 sec
DRV-02	Dec time	Dec time 0	0	0	0	30 sec
I/O-50	ACC-1	Acc time 1	0	0	1	20 sec
I/O-51	DEC-1	Dec time 1	0	0	1	20 sec
I/O-52	ACC-2	Acc time 2	0	1	0	30 sec
I/O-53	DEC-2	Dec time 2	0	1	0	30 sec
I/O-54	ACC-3	Acc time 3	0	1	1	40 sec
I/O-55	DEC-3	Dec time 3	0	1	1	40 sec
I/O-56	ACC-4	Acc time 4	1	0	0	50 sec
I/O-57	DEC-4	Dec time 4	1	0	0	50 sec
I/O-58	ACC-5	Acc time 5	1	0	1	40 sec
I/O-59	DEC-5	Dec time 5	1	0	1	40 sec
I/O-60	ACC-6	Acc time 6	1	1	0	30 sec
I/O-61	DEC-6	Dec time 6	1	1	0	30 sec
I/O-62	ACC-7	Acc time 7	1	1	1	20 sec
I/O-63	DEC-7	Dec time 7	1	1	1	20 sec

FU2-74 [Accel/Decel time scale]

Set the Accel/Decel time unit.

* Up to 6000 sec settable via LE-200 keypad.

Setting	Unit	Description
0	0.01 sec	Minimum 0 sec settable Maximum 60 sec settable
1	0.1 sec	Minimum 0 sec settable Maximum 600 sec settable (Factory setting)
2	1 sec	Minimum 0 sec settable Maximum 6000 sec settable*

DRV-03: Drive Mode (Run/Stop Method)

DRV▶ Drive mode 03 Fx/Rx-1	03	1
-------------------------------	-----------	----------

Factory Default: Fx/Rx-1 **1**

Select the source of run/stop command.

Setting Range	Description
Keypad	Run/Stop control by Keypad.
Fx/Rx-1	Run/Stop control by Control Terminals FX, RX. (Method 1) FX: Forward Run/Stop RX: Reverse Run/Stop
Fx/Rx-2	Run/Stop control by Control Terminals FX, RX. (Method 2) FX: Run/Stop command RX: Forward/Reverse selection
Int. 485	Run/Stop control by RS485.

DRV-04: Frequency Mode

DRV▶ Freq mode 04 Keypad-1	04	0
-------------------------------	-----------	----------

Factory Default: Keypad-1 **0**

If the DRV-04 [Frequency Mode] is set to V1, V1S, I, V1+I, see the description of I/O-01~16 [Analog Voltage/Current input signal adjustment].

Setting Range	Description
Keypad-1	Frequency is set at DRV-00. The frequency is changed by pressing PROG key and entered by pressing ENT key. The inverter does not output the changed frequency until the ENT key is pressed.
Keypad-2	Frequency is set at DRV-00. Press PROG key and then by pressing the ▲ , ▼ key, the inverter immediately outputs the changed frequency. Pressing the ENT key saves the changed frequency.
V1	Apply the frequency reference (0-12V) to the "V1" control terminal. Refer to the I/O-01 to I/O-05 for scaling the signal.
V1S	Apply the frequency reference -12~12V to terminal V1. Refer to the I/O-01 to I/O-05

Chapter 6 - Parameter Description [DRV]

Motor speed = 120 * (F/P) * FU2-47

Where, F= Output Frequency and P= the Number of Motor Poles

DRV-10: DC Link Voltage

DRV▶ DC link vtg
10 ----- V

10

Factory Default: ----- V ----

This code displays the DC link voltage inside the inverter.

DRV-11: User Display Selection

DRV▶ User disp
11 0.0 V

11

0.0

Factory Default: 0.0 V **0.0**

This code displays the parameter selected in FU2-81 [User Display]. One of Voltage (factory default, output voltage display) or Watt (output power display) is selectable.

DRV-12: Current Trip Display

DRV▶ Fault
12 None

12

n0n

Factory Default: None **n0n**

This code displays the current fault (trip) status of the inverter. Use the **[PROG]**, **[▲]** and **[▼]** key before pressing the **[RESET]** key to check the fault content(s), output frequency, output current, and whether the inverter was accelerating, decelerating, or in constant speed at the time of the fault occurred. Press the **[ENT]** key to exit. The fault content will be stored in FU2-01 to FU2-05 when the **[RESET]** key is pressed. For more detail, please refer to Chapter 7. Troubleshooting and Maintenance.

[Fault Contents]

Fault (Trip)	LCD Keypad display
Over-Current 1	Over Current 1
Over-Voltage	Over Voltage
External Trip Input	Ext. Trip
Emergency Stop (Not Latched)	BX
Low-Voltage	Low Voltage
Ground Fault	Ground Fault
Over-Heat on Heat sink	Over Heat
Electronic Thermal Trip	E-Thermal
Over-Load Trip	Over Load
Inverter H/W Fault - EEP Error - ADC Offset - WDOG Error - In-Phase Open	HW-Diag
Over-Current 2	Over Current 2
Output Phase Loss	Phase Open
Inverter Over-Load	Inv. OLT

Note: There are WDOG error, EEP error, Input Phase Open and ADC Offset for the inverter Hardware Fault. Inverter will not reset when H/W fault occurs. Repair the fault before turning on the power.

Note: Only the highest-level fault will be displayed when multiple faults occur. The rest of faults can be monitored in FU2-01~05 [Fault history]. Cycle the power when the fault is cleared.

Up to 5 faults can be saved in FU2-01~05 [Fault history]. The lowest hierarchy fault such as “Last trip 5” is the latest. After pressing [PROG] key, press [↑(Up)], [↓(Down)] key to check the operation information at the time of the fault (Output freq., current, Accel/Decel/Constant Run) and fault type. Press the [ENT] key to escape.

FU2-06 [Erase fault history] clears the faults information. However, FU2-83 [Last Trip Time] is automatically reset when a trip occurs.

Code	Display	Description
FU2-01	Last trip-1	Fault history 1
FU2-02	Last trip-2	Fault history 2
FU2-03	Last trip-3	Fault history 3
FU2-04	Last trip-4	Fault history 4
FU2-05	Last trip-5	Fault history 5

FU2-83 [Last Trip Time] shows the total time elapsed after the last trip occurs so it is possible to know the actual trip time by recounting.

DRV-20: EXT-PID Parameter
(To monitor ExtPID controller's reference/ feedback/ output value)

Displays ExtPID controller's reference/ feedback/ output value.

When APP-80 [Ext. PID operation selection] is set to "YES," reference and feedback are displayed in Percent unit.

When APP-02 [PID operation selection] is set to "YES," and APP-06 [PID feedback selection] is set (one of the I, V1, Pulse) and the desired unit is set in I/O-86 [V1 Unit Sel], I/O-87 [I Unit Sel], I/O-88 [PulseUnitSel] according to the selection in APP-06, PID reference and feedback value will be displayed by percent [%] unit.



- DRV-93: FU1 Group Selection (7-Seg.keypad Only)
- DRV-94: FU2 Group Selection
- DRV-95: I/O Group Selection
- DRV-96: EXT Group Selection
- DRV-97: COM Group Selection
- DRV-98: APP Group Selection

Select the desired group and press the **PROG/ENT** key to move into the desired group. The parameter in the group can be read and written after moving into the desired group.

6.2 Function 1 Group [FU1]

FU1-00: Jump to Desired Code #

FU1▶ Jump code
00 1

Factory Default: 1 1

Jumping directly to any parameter code can be accomplished by entering the desired code number. This code is available only with LCD keypad.

FU1-01: Run Prevention

FU1▶ Run prev. 01 None **01** **0**

Factory Default: None 0

This function prevents reverse operation of the motor. This function may be used for loads that rotate only in one direction such as fans and pumps.

Setting Range	Description
None	Forward & Reverse run available. (Factory default)
Forward Prev	Forward run prohibited.
Reverse Prev	Reverse run prohibited.

**FU1-02: Acceleration Pattern
FU1-03: Deceleration Pattern**

FU1▶ Acc. pattern 02 Linear **02** **0**

Factory Default: Linear 0

FU1▶ Dec. pattern 03 Linear **03** **0**

Factory Default: Linear 0

Different combinations of acceleration and deceleration patterns can be selected according to the application.

Setting Range	Description
Linear	A general pattern for constant torque applications. (Factory default)
S-curve	This pattern allows the motor to accelerate and decelerate smoothly. The actual acceleration and deceleration time takes longer- about 40% than the time set in DRV-01 and DRV-02. This setting prevents shock during acceleration and deceleration, and prevents objects from swinging on conveyors or other moving equipment.
U-curve	This pattern provides more efficient control of acceleration and deceleration in typical winding machine applications.

Note: Setting value in DRV-01 and DRV-02 is ignored.

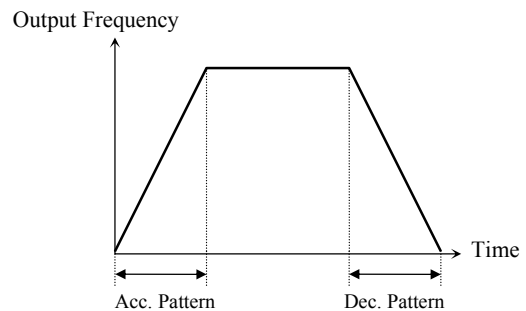

[Accel/Decel Pattern: 'Linear']

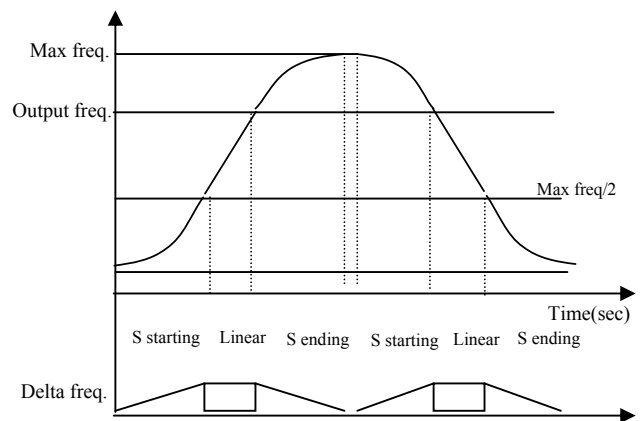

[Accel/Decel Pattern: 'S-curve']

Actual accel time = Preset accel time+ Preset accel time *Starting curve ratio/2 + Preset accel time * Ending curve ratio /2
 Actual decel time = Preset decel time + Preset decel

time * Starting Curve ratio/2 + Preset decel time *
Ending curve ratio/2

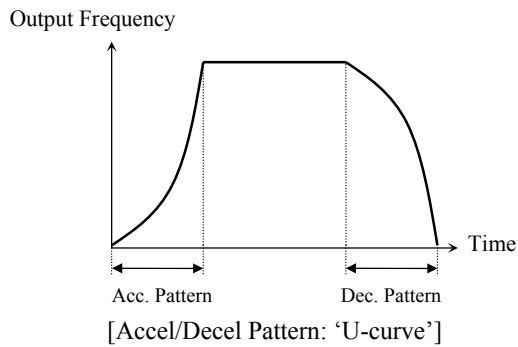

FU1-10-12: Pre-heat (to use Pre-heat function)

FU1▶Pre-HeatMode		
10	No	10 0
Factory Default:	No	0

This function enables a motor to prevent moisture from entering and not to develop condensation inside at stop in a humid area by supplying DC current to the motor continuously.

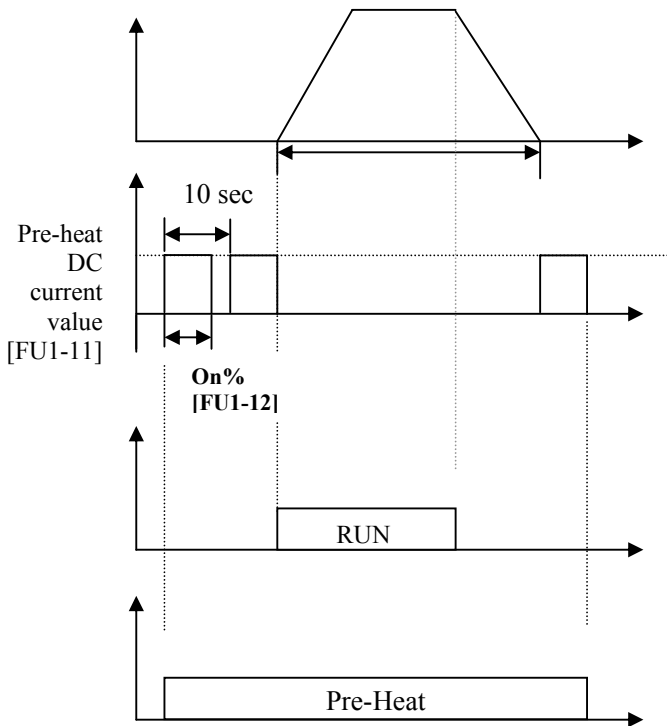

Pre-heat function is activated when FU1-10 [Pre-heat] is set to “Yes”, one of the Programmable digital input terminals in I/O-20~27 set to “Pre-heat” and the defined terminal is turned ON. Only active at inverter stop.

- FU1-11 [Pre-heat value] is set in percent of motor rated current.
- FU1-12 [Pre-heat duty] sets the duty for 10 seconds. At 100% setting, DC current is continuously supplied to the motor.

- ⚠ **Caution:** Parameter change is disabled during pre-heat function. Remove the reference command at the terminal before programming.
- ⚠ **Caution:** Reduce FU1-11 [Pre-heat value] or FU2-12 [Pre-heat duty] when inverter or motor is overheated.

FU1-20: Start Mode
 FU1-21: Starting DC Magnetizing Time
 FU1-22: Starting DC Magnetizing Value

FU1▶ DcSt time
 21 0.0 sec **21** **0.0**

Factory Default: 0.0 sec **0.0**

FU1▶ DcSt value
 22 50 % **22** **50**

Factory Default: 50 % **50**

Inverter holds the starting frequency for Starting DC Magnetizing Time. It outputs DC voltage to the motor for FU1-21 [Starting DC Magnetizing Time] with the FU1-22 [Starting DC Magnetizing Value] before accelerating.

Select the starting method of the inverter.

	FU1-20 set data	Function description
0	Accel	Acceleration to start (Factory default)
1	Dc-start	Inverter starts acceleration after magnetizing DC current.
2	Flying-start	Inverter starts RUN while a motor is rotating.

- 1) The direction of Motor rotation and the command should be set equal to optimum use of Flying-start function. **However, this function is effective with less than 50% to rated rpm when direction of motor rotation and reference command is opposite.**
- 2) DC-start is disabled when FU1-21 or 22 is set to "0".
- 3) DC-start is deactivated in Sensorless mode.
- 4) It is possible to occur No Motor Trip in case that there is output phase loss when DC-start is operated

Inverter starts acceleration after FU1-21 [Starting DC Magnetizing Time] while FU1-22 [Starting DC Magnetizing Voltage] is operated.

Code	LCD Display	Default	Setting
FU1-21	DcSt time	0 [sec]	0 ~ 60 [sec]
FU1-22	DcSt value	50 [%]	0 ~ 150 [%]

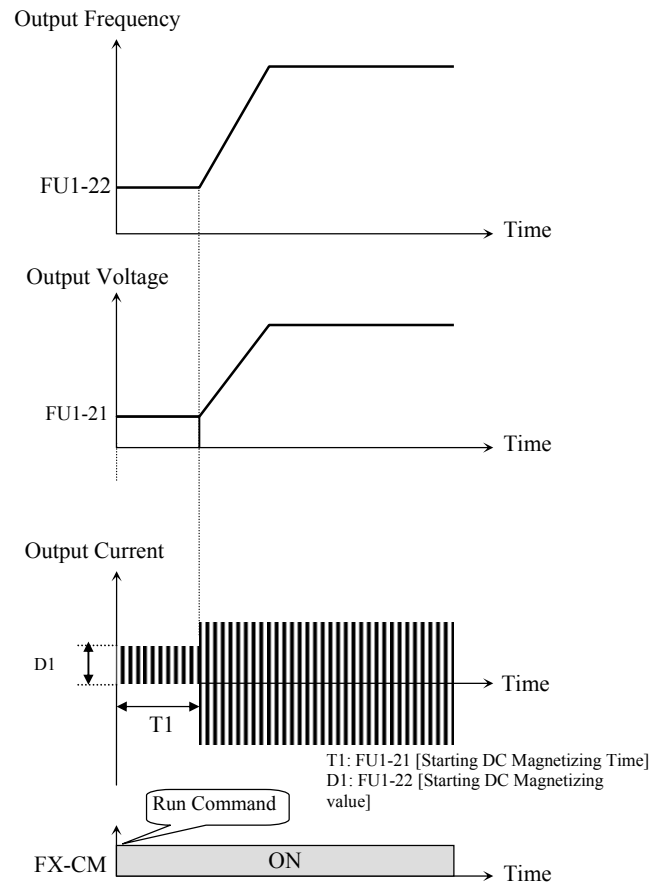

[DC-start Operation]

FU1-22 [Starting DC Magnetizing Value] is the DC Current amount applied to the motor and is set as percent of FU2-43[Motor Rated Current].

Note: Do not set FU1-22 [Starting DC Magnetizing Value] higher than Inverter Rated Current. Otherwise, Motor Overheating or Overload Trip may occur.

FU1-23: Stop Mode

FU1▶ Stop mode	23	0
23 Decel		

Factory Default: Decel	0
------------------------	----------

Sets the stopping method for the inverter.

Setting Range	Description
Decel	Inverter stops by the deceleration pattern.
Dc-brake	Inverter stops with DC injection braking. Inverter outputs DC voltage when the frequency reached the DC injection braking frequency during decelerating.
Free-run (Coast to stop)	Inverter cuts off its output immediately when the stop signal is commanded.
Flux brake	Fast stop is available by converting the regenerating energy into heat at the motor.

Caution: Motor may be overheated due to frequent use of Flux Brake function.

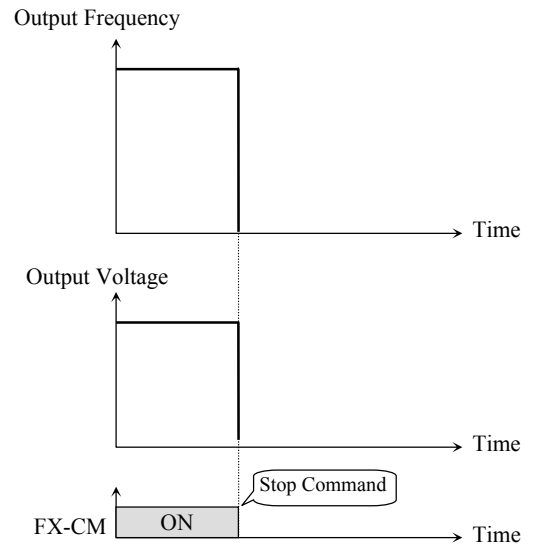

[Stop mode: Free-run]

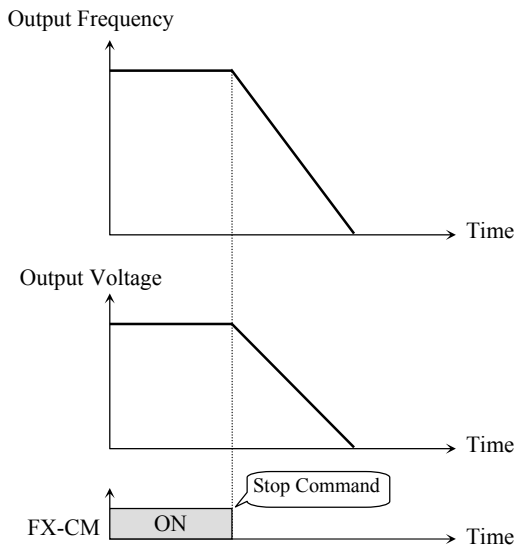

[Stop Mode: 'Decel']

FU1-24: DC Injection Braking Hold Time
FU1-25: DC Injection Braking Frequency
FU1-26: DC Injection Braking Time
FU1-27: DC Injection Braking Value

FU1▶ DcBlk time
 24 0.10 sec **24** **0.10**

Factory Default: 0.10 sec **0.10**

FU1▶ DcBr freq
 25 5.00 Hz **25** **5.00**

Factory Default: 5.00 Hz **5.00**

FU1▶ DcBr time
 26 1.0 sec **26** **1.0**

Factory Default: 1.0 sec **1.0**

FU1▶ DcBr value
 27 50 % **27** **50**

Factory Default: 50 % **50**

By introducing a DC voltage to the motor windings this function stops the motor immediately. Selecting 'DC-Brake' in FU1-23 activates FU1-24 through FU1-27.

When FU1-23 [Stop mode] is set to "DC Brake", inverter decelerates until FU1-25 [DC Injection Braking Frequency] and begins DC Braking at this frequency.

FU1-24 [DC Injection Braking Hold Time] is the inverter output blocking time before DC injection braking.

FU1-25 [DC Injection Braking Frequency] is the frequency at which the inverter starts to output DC voltage during deceleration.

FU1-26 [DC Injection Braking Time] is the time the DC current is applied to the motor.

FU1-27 [DC Injection Braking Value] is the DC voltage applied to the motor and is based on FU2-43[Rated Current of Motor].

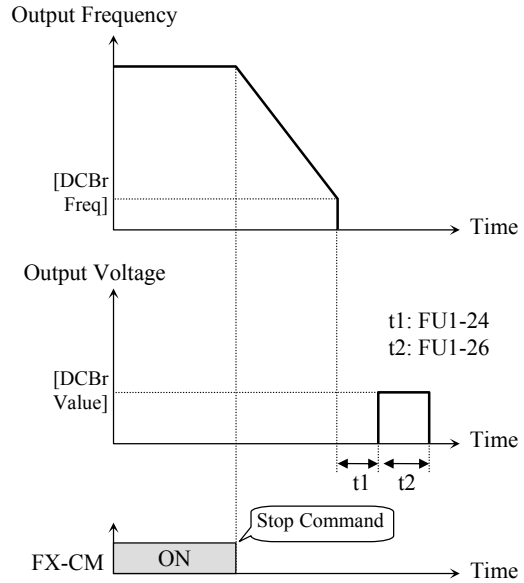

[DC Injection Braking Operation]

Note: Do not set the FU1-27 higher than Inverter rated current. Otherwise, it may lead to motor overheat or overload trip.

Note: Do not set FU1-27 [DC Braking Frequency] too high than its range (between 0~5Hz). Otherwise, it may deteriorate its performance.

FU1-28: Safety Stop

FU1▶ Safety Stop
 28 No **28** **0**

Factory Default: No **0**

This function is used to prevent potential danger from occurring when the whole system is stopped by power outage but the load keeps spinning due to high load inertia.

When momentary power failure occurs while Safety Stop is active, inverter stops the motor by deceleration. Deceleration time depends on load inertia energy.

If the load inertia rate is far different between the factory set value and an actual value, set the proper value in FU2-46 [Load Inertia] for optimum use of the Safety Stop function. When the load inertial is large, trip may occur during this function. In this case, increase the FU2-46 [Load Inertia] value little by little to find the proper value. For more stable Safety

Stop Function, see FU1-90[Safety Stop Inertia Rate].

Caution: This function is effective for high load inertia.

FU1-29: Line Frequency

FU1▶ Line Freq	29	60.00 Hz	29	60.00
----------------	----	----------	-----------	--------------

Factory Default:	60.00 Hz	60.00
------------------	----------	--------------

It sets input power frequency. Set 50 or 60Hz in FU1-29 [Line Frequency].

Caution: If line frequency is changed, related frequencies such as Max frequency, Base frequency are automatically changed. To set the related frequencies different to line, user should set the codes manually.

FU1-30: Maximum Frequency
FU1-31: Base Frequency
FU1-32: Starting Frequency

FU1▶ Max freq	30	60.00 Hz	30	60.00
---------------	----	----------	-----------	--------------

Factory Default:	60.00 Hz	60.00
------------------	----------	--------------

FU1▶ Base freq	31	60.00 Hz	31	60.00
----------------	----	----------	-----------	--------------

Factory Default:	60.00 Hz	60.00
------------------	----------	--------------

FU1▶ Start freq	32	0.50 Hz	32	0.50
-----------------	----	---------	-----------	-------------

Factory Default:	0.50 Hz	0.50
------------------	---------	-------------

FU1-30 [Maximum Frequency] is the maximum output frequency of the inverter. Make sure this maximum frequency does not exceed the rated speed of the motor.

FU1-31 [Base Frequency] is the frequency where the inverter outputs its rated voltage. In case of using a 50Hz motor, set this to 50Hz.

FU1-32 [Starting Frequency] is the frequency where the inverter starts to output its voltage. **If it is set to 5Hz, motor starts running from 5 Hz.**

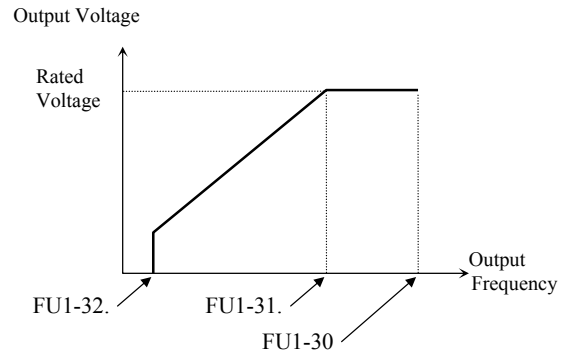

Caution: Note that these codes setting is automatically changed when FU1-30 and FU1-31 are set before setting FU1-29 [Line Frequency].

Caution: Note that Overheat trip or torque shortage may occur if FU1-31 is set different to motor rated frequency.

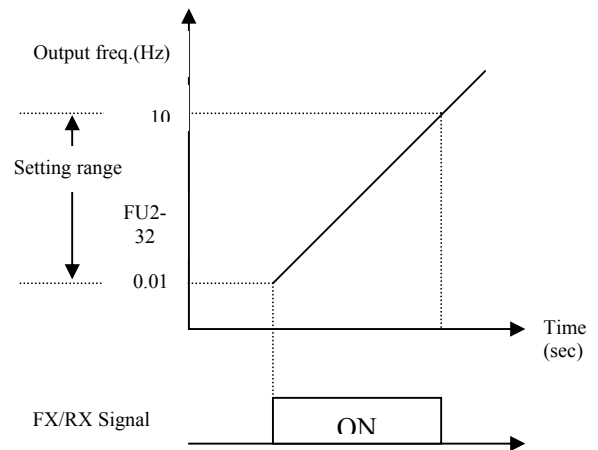

Note: Motor starts running at 5Hz when FU2-32 is set to 5Hz.

FU1-33: Frequency Limit Selection
FU1-34: Low Limit Frequency
FU1-35: High Limit Frequency

FU1▶ Freq limit 33 No	33	0
--------------------------	-----------	----------

Factory Default: No	0
---------------------	----------

FU1▶ F-limit Lo 34 0.50 Hz	34	0.50
-------------------------------	-----------	-------------

Factory Default: 0.50 Hz	0.50
--------------------------	-------------

FU1▶ F-limit Hi 35 60.00 Hz	35	60.00
--------------------------------	-----------	--------------

Factory Default: 60.00 Hz	60.00
---------------------------	--------------

FU1-33 selects the limits the inverter operating frequency. If FU1-33 is set to 'Yes', inverter operates within the upper and lower limit setting. The inverter operates at the upper or the lower limit when the frequency reference is outside the frequency limit range.

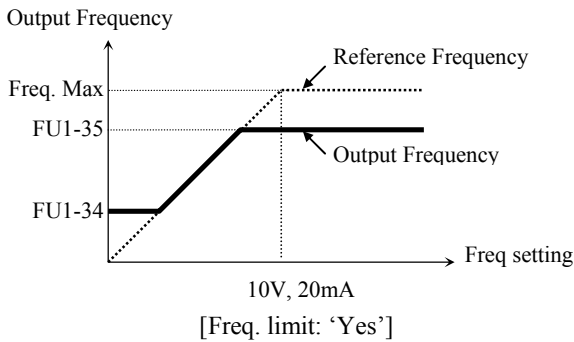

Note: if freq set value is below freq low limit, inverter operates at the low limit.

Note: Normal Accel/Decel is performed for the range below low limit during Accel/Decel.

FU1-40: Volts/Hz Pattern

FU1▶ V/F pattern 40 Linear	40	0
-------------------------------	-----------	----------

Factory Default: Linear	0
-------------------------	----------

This is the pattern of voltage/frequency ratio. Select the proper V/F pattern according to the load. The motor torque is dependent on this V/F pattern.

[Linear] pattern is used where constant torque is required. This pattern maintains a linear volts/frequency ratio from zero to base frequency. This pattern is appropriate for constant torque applications. The performance will be improved with the help of FU2-67~69 [Torque boost].

[Square] pattern is used where variable torque is required. This pattern maintains squared volts/hertz ratio. This pattern is appropriate for fans, pumps, etc.

[User V/F] pattern is used for special applications. Users can adjust the volts/frequency ratio according to the application. This is accomplished by setting the voltage and frequency, respectively, at four points between starting frequency and base frequency. The four points of voltage and frequency are set in FU1-41 through FU1-48.

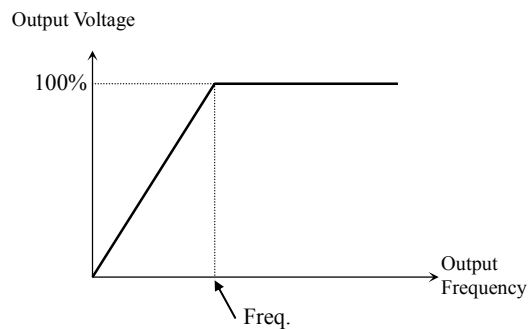

[V/F Pattern: 'Linear']

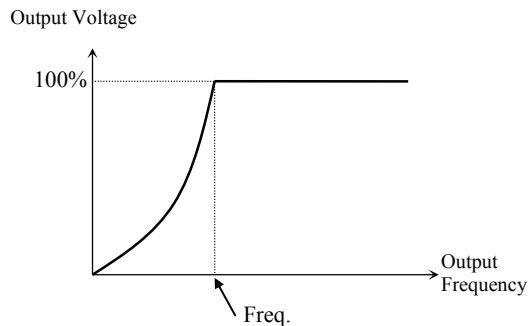

[V/F Pattern: 'Square']

FU1-41 ~ FU1-48: User V/F Frequency and Voltage

FU1▶ User freq 1
41 15.00 Hz **41** **15.00**

Factory Default: 15.00 Hz **15.00**

FU1▶ User volt 1
42 25 % **42** **25**

Factory Default: 25 % **25**

-
-
-

FU1▶ User freq 4
47 60.00 Hz **47** **60.00**

Factory Default: 60.00 Hz **60.00**

FU1▶ User volt 4
48 100 % **48** **100**

Factory Default: 100 % **100**

These functions are available only when 'User V/F' is selected in FU1-40 [V/F pattern]. Users can make the custom V/F pattern by setting four points between FU1-32 [Starting Frequency] and FU1-31 [Base Frequency].

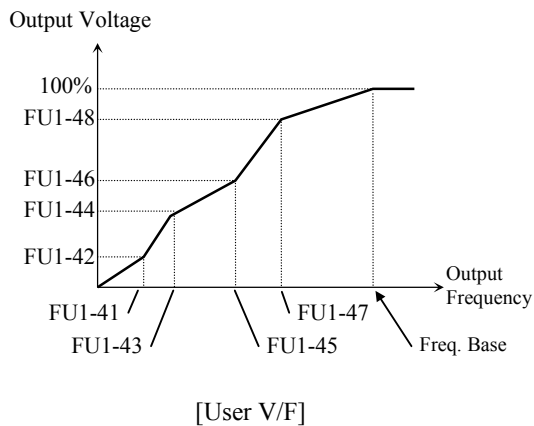

Note: When the 'User V/F' is selected, the torque boost of FU1-67 through FU1-69 is ignored.

FU1-49: AC Input Voltage Adjustment

FU1▶ VAC 440.0V
49 100.0 % **49** **100.0**

Factory Default: 100.0 % **100.0**

It should be set correctly when inverter input voltage and standard input power rating is far different. Otherwise, it will cause inverter damage. This set value affects inverter LV trip (low voltage trip) level. Used only when line fluctuation exceeds its permissible range or input power far different to its standard value is applied.

Code	LCD Display	Default	Setting
FU1-49	AC Input Volt	100 [%]	73 – 115 [%]

Note: As soon as FU1-49 value is set through a button on the keypad, its set value is applied.

FU1-50: Motor Voltage

FU1▶ Motor Volt
50 0 V **50** **0**

Factory Default: 0 V **0**

Constant voltage output is possible regardless of input voltage fluctuation by setting this parameter.

Caution: When input voltage is less than FU1-50 [Motor rated voltage], Max output voltage cannot exceed input voltage.

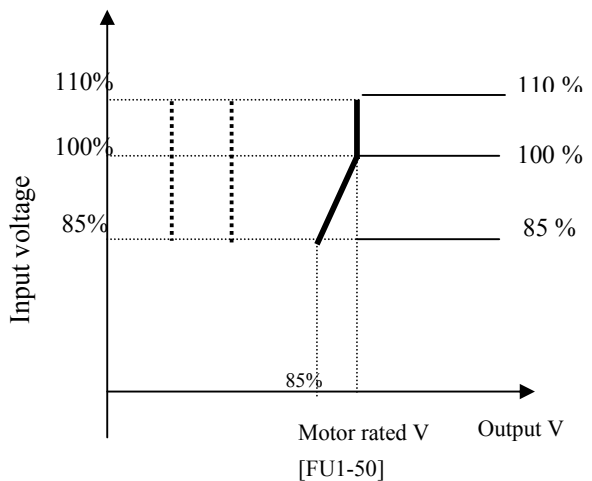

FU1-57: No Motor Sel
 FU1-58: No Motor Level
 FU1-59: No Motor Time

FU1▶ No Motor Sel
 57 No

Factory Default: No

FU1▶ NoMotorLevel
 58 5 %

Factory Default: 5

FU1▶ NoMotorTime
 59 3.0 sec

Factory Default: 3.0 sec

These functions can be used to generate Trip in the situation such that there is no actual inverter output but the Main Controller of its hardware does not recognize it. (Damage of SPS for Gate and Damage of Gate, etc.)

When FU1-57 [No Motor Sel] is set to 'Yes', the current below FU1-58 [No Motor Level] set value flows, and FU1-59 [No Motor Time] set time is passed, HW-Diag Trip is occurred and the message 'No Motor Trip' is displayed on the LCD for this trip. (The current level is based on the set Motor rated current.)

Trip occurs when the inverter is operated without wiring a motor.

Description	LCD Display	Setting Range
No Motor Selection	No Motor Sel	0 (No) 1 (Yes)
Trip Current Level	No Motor Level	5 – 100 [%]
Trip Time Setting	No Motor Time	0.5 – 10.0 [sec]

FU1-60: Electronic Thermal (Motor i²t) Selection
 FU1-61: Electronic Thermal Level for 1 Minute
 FU1-62: Electronic Thermal Level for Continuous
 FU1-63: Electronic Thermal Characteristic (Motor type) selection

These functions protect the motor from overheating without using external thermal relay. Inverter calculates the temperature rise in a motor based on several parameters and determines whether or not the motor is overheated from load current. Inverter will turn off its output and display a trip message when the electronic thermal feature is activated.

FU1▶ ETH select
 60 --- Yes --- **60** **1**

Factory Default: Yes **1**

This function activates the ETH parameters by setting 'Yes'. ETH level is set as the percentage of FU2-43 [Motor rated current].

FU1▶ ETH 1min
 61 150 % **61** **150**

Factory Default: 150 % **150**

This is the reference current when the inverter determines the motor has overheated. For example, it trips in one minute when 150% of rated motor current in FU2-43 flows for one minute.

Note: The set value is the percentage of FU2-43 [Rated Motor Current].

FU1▶ ETH cont
 62 120 % **62** **120**

Factory Default: 120 % **120**

This is the current at which the motor can run continuously. Generally, this value is set to '100%', which means the motor rated current set in FU2-43. This value must be set less than FU1-61 [ETH 1min].
Note: The set value is the percentage of FU2-43 [Rated Motor Current].

FU1▶ Motor type	63	0
63 Self-cool		

Factory Default: Self-cool	0
----------------------------	---

To make the ETH function (Motor i^2t) work correctly, the motor cooling method must be selected correctly according to the motor.

[Self-cool] is a motor that has a cooling fan connected directly to the shaft of the motor. Cooling effects of a self-cooled motor decrease when a motor is running at low speeds. The Motor is easily heated at low speed, compared to the motor at high speed with the same current. The motor current is derated as the motor speed decreases as shown below.

[Forced-cool] is a motor that uses a separate motor to power a cooling fan. As the motor speed changes, the cooling effect does not change. FU1-62 [Electronic thermal level for continuous] set value is applied regardless of operating frequency.

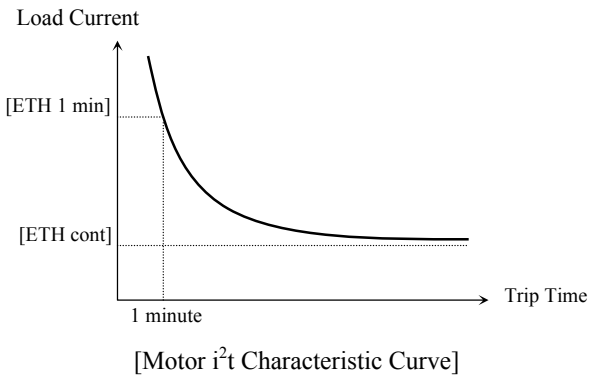
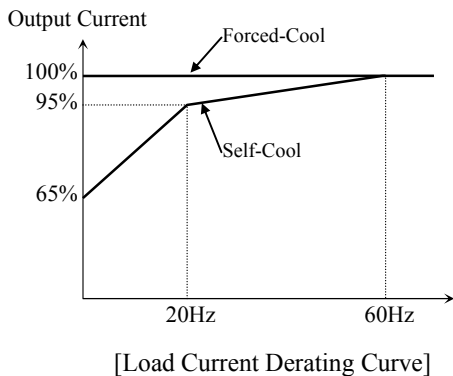

Note: Despite the motor current changing frequently due to load fluctuation or acceleration and deceleration, the inverter calculates the i^2t

and accumulates the value to protect the motor.

FU1-64: Overload Warning Level	FU1-65: Overload Warning Time
--------------------------------	-------------------------------

FU1▶ OL level	64	110
64 110 %		

Factory Default: 110 %	110
------------------------	-----

FU1▶ OL time	65	10.0
65 10.0 sec		

Factory Default: 10.0 sec	10.0
---------------------------	------

The inverter generates an alarm signal when the output current has reached the FU1-64 [Overload Warning Level] for the FU1-65 [Overload Warning Time]. The alarm signal persists for the FU1-65 even if the current has become the level below the FU1-64. Programmable Digital Output Terminal (AX-CX) is used as the alarm signal output. To output the alarm signal, set I/O-76 [Multifunction Auxiliary Contact Output] to 'OL'.

Note: FU1-64 is set as the percentage of FU2-43 [Rated Motor Current].

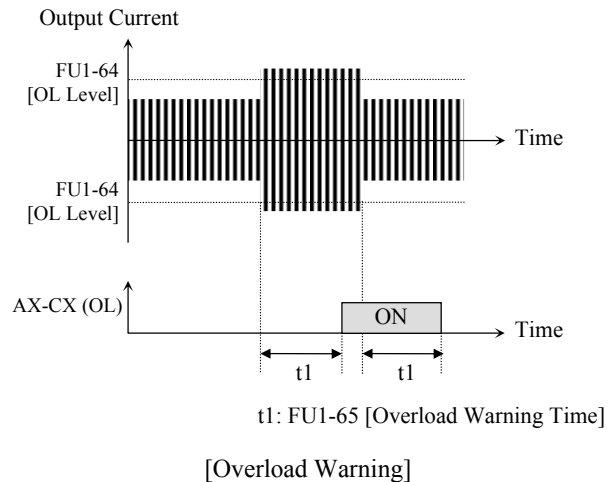

FU1-66: Overload Trip Selection
FU1-67: Overload Trip Level
FU1-68: Overload Trip Delay Time

FU1▶ OLT select 66 --- No ---	66	0
----------------------------------	-----------	----------

Factory Default: No		0
---------------------	--	----------

FU1▶ OLT level 67 120 %	67	120
----------------------------	-----------	------------

Factory Default: 120 %		120
------------------------	--	------------

FU1▶ OLT time 68 60.0 sec	68	60.0
------------------------------	-----------	-------------

Factory Default: 60.0 sec		60.0
---------------------------	--	-------------

Inverter cuts off its output and displays fault message when the output current persists over the FU1-67 [Overload Trip Level] for the time of FU1-68 [Overload Trip Time]. This function protects the inverter and motor from abnormal load conditions.

Note: The set value is the percentage of FU2-43 [Rated Motor Current].

Note: Activated only when Heatsink temperature exceeds its preset level.

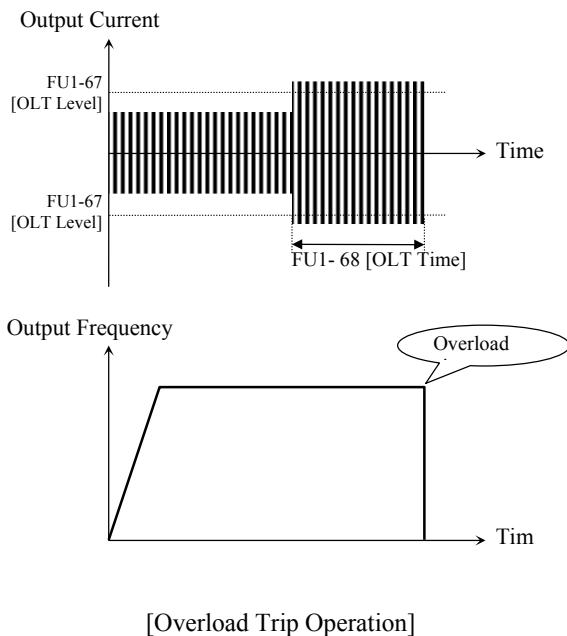

FU1-69: Input/Output Phase Loss Protection (Bit Set)

FU1▶ Trip select 69 100	69	100
----------------------------	-----------	------------

Factory Default: 100		100
----------------------	--	------------

This function is used to cut the inverter output off in case of phase loss in either input power or inverter output.

1st bit: Output phase loss protection

Enable/Disable

0: Disabled at Output phase loss protection.

1: Enabled at Output phase loss protection.

Inverter output is shut down and stopped.

2nd bit: Input phase loss protection Enable/Disable

0: Input phase loss protection disabled.

1: Input phase loss protection enabled. Inverter output is shut down and stopped.

3rd bit: Protection Enable/Disable selection at Exchange function

0: Disabled at Exchange function (Inverter-Commercial line exchange).

1: Enabled at Exchange function.

FU1-70: Stall Prevention Mode (Bit set)
FU1-71: Stall Prevention Level

FU1▶ Stall prev. 70 000	70	000
----------------------------	-----------	------------

Factory Default: 000		000
----------------------	--	------------

This bit set parameter follows the conventions used in I/O-15 and I/O-16 to show the ON (bit set) status.

FU1▶ Stall level 71 100 %	71	100
------------------------------	-----------	------------

Factory Default: 100 %		100
------------------------	--	------------

This function is used to prevent the motor from stalling by reducing the inverter output frequency until the motor current decreases below the stall prevention level. This function can be selected for each mode of acceleration, steady speed, and deceleration via bit combination.

Note: FU1-71 is set as the percentage of FU2-43 [Rated Motor Current].

Note: Do not set the FU1-71 higher than inverter rated current.

Note : Stall level will be automatically reduced if inverter is operated at the frequency higher than base frequency.

FU1-70 [Stall Prevention Mode Selection]

Setting Range			FU1-70	Description
3 rd bit	2 nd bit	1 st bit		
0	0	1	001	Stall Prevention during Acceleration
0	1	0	010	Stall Prevention during Constant Run
1	0	0	100	Stall Prevention during Deceleration

When FU1-70 is set to '111', stall prevention works during accelerating, steady speed and decelerating.

Note: Accel time may get longer due to stall prevention during Accel.

Note: Inverter starts deceleration when Stop command is applied while motor stall state persists.

Note: Output frequency may oscillates due to stall prevention during constant run.

Note: Decel time may get longer due to stall prevention during Decel.

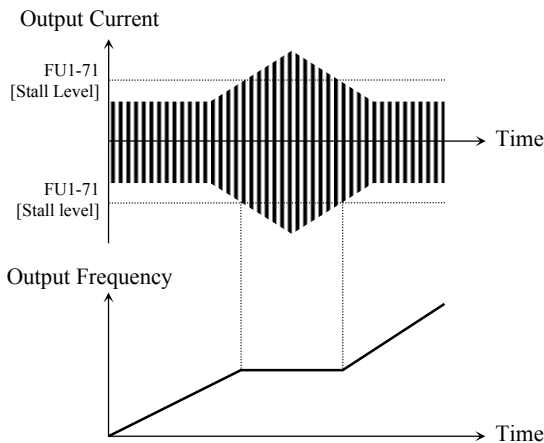

[Stall Prevention during Acceleration]

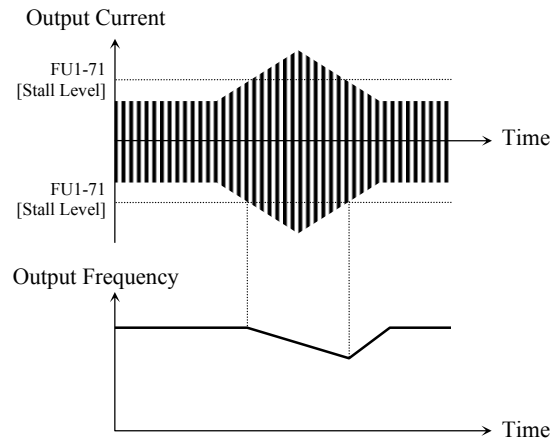

[Stall Prevention during Constant Run]

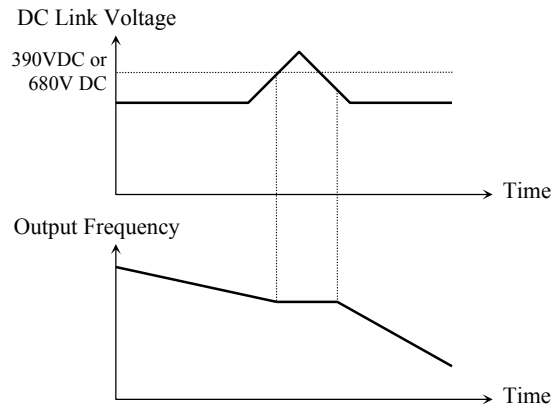

[Stall Prevention during Deceleration]

FU1-72: Accel/Decel Change Frequency

FU1▶Acc/Dec ch F	72	0.00
72	0.00 Hz	

Factory Default: 0.00 Hz **0.00**

This function is used to change Accel/Decel ramp at a certain frequency. This is useful in textile machine application. For example, when stop command is ON while inverter runs at 100Hz, inverter swiftly decelerates and changes the ramp at this frequency, leading to soft stop.

Note: If Accel/Decel change frequency is set and 'XCEL-L', XCEL-M', and XCEL-H' defined in Programmable digital terminals are ON, Multi Accel/Decel operation has the priority.

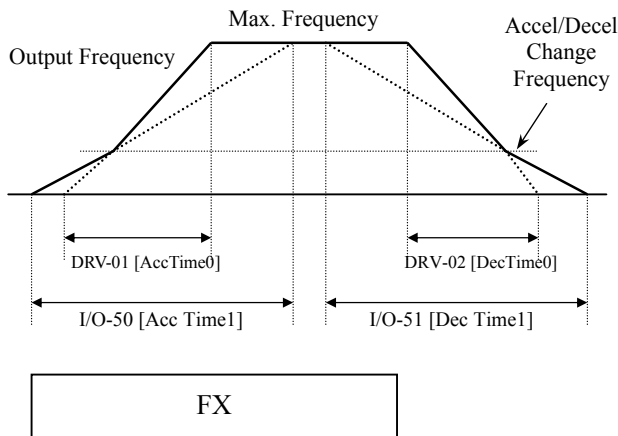

[Accel/Decel Change Operation]

FU1-73: Reference Frequency for Accel/Decel

FU1▶Acc/Dec freq	73	0
73 Max		

Factory Default: Max **0**

This is the reference frequency for acceleration and deceleration. If a decided Accel/Decel time from a frequency to a target frequency is required, set this value to 'Delta freq'.

Setting Range	Description
Max freq	The Accel/Decel time is the time that takes to reach the maximum frequency from 0 Hz.
Delta freq	The Accel/Decel time is the time that takes to reach a target frequency.

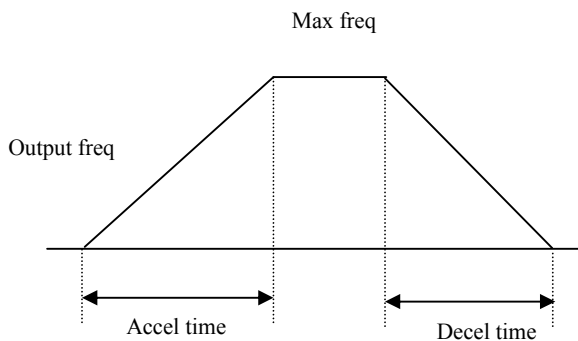

[FU1-73: Max. Freq]

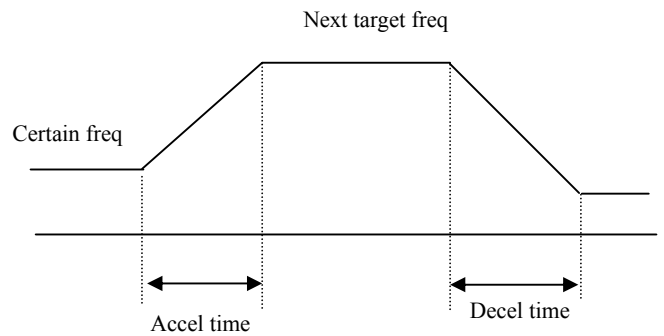

[FU1-73: Delta Freq]

FU1-74: Accel/Decel Time Scale

FU1▶ Time scale	74	1
74 0.1 sec		

Factory Default: 0.1 sec **1**

This is used to change the time scale.

Setting Range	Description
0.01 sec	The Accel/Decel time is changed by 10 msec. The maximum setting range is 60 seconds.
0.1 sec	The Accel/Decel time is changed by 100 msec. The maximum setting range is 600 seconds.
1 sec	The Accel/Decel time is changed by 1 sec. The maximum setting range is 6000 seconds.

FU1-90: Safety STOP Inertia Rate

FU1▶STOP Inertia	90	10
90 10		

Factory Default: 10 **10**

This is used to find a proper inertia value for Safety STOP function. The suitable value can be found while lowering it when occurring OV Trip or raising it when occurring LV Trip during Safety STOP operation.

6.3 Function 2 Group [FU2]

FU2-00: Jump to desired code #

FU2▶ Jump code
00 1

Factory Default: 1 1

Jumping directly to any parameter code can be accomplished by entering the desired code number. This code is available only with LCD keypad.

FU2-01: Last trip 1
FU2-02: Last trip 2
FU2-03: Last trip 3
FU2-04: Last trip 4
FU2-05: Last trip 5
FU2-06: Erase Trips

FU2▶ Last trip-1
01 None 01 n0n

Factory Default: None n0n

-
-
-

FU2▶ Last trip-5
05 None 05 n0n

Factory Default: None n0n

This code displays up to five previous fault (trip) status of the inverter. Use the **PROG**, **▲** and **▼** key before pressing the **RESET** key to check the fault content(s) such as output frequency, output current, and whether the inverter was accelerating, decelerating, or in constant speed at the time of the fault occurred. Press the **ENT** key to exit. FU2-83 [Last Trip Time] is the time elapsed after last trip occurs. User can count the last trip time from this value.

Note: There are WDOG error, EEP error, and ADC Offset for the inverter Hardware Fault, and the inverter will not reset when H/W fault occurs. Repair the fault before turning on the power.

FU2▶ Erase trips
06 --- No --- 06 0

Factory Default: No 0

This function erases all fault histories of FU2-01 to FU-05 from the memory. However, FU2-83 [Last Trip Time] cannot be reset.

**FU2-07: Dwell Time
FU2-08: Dwell Frequency**

FU2▶ Dwell time
07 0.0 sec 07 0.0

Factory Default: 0.0 sec 0.0

FU2▶ Dwell freq
08 5.00 Hz 08 5.00

Factory Default: 5.00 Hz 5.00

Note: If the dwell time is set at '0', this function is not available.

Note: Do not set the Dwell frequency above frequency command. Otherwise, it may lead to operation fault.

Note: this function is disabled in Sensorless control.

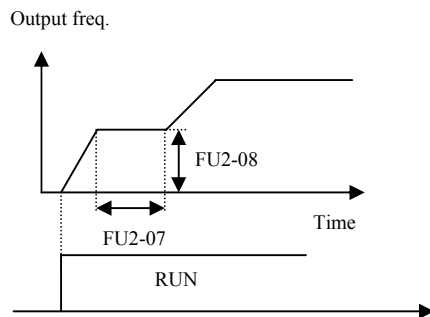

FU2-10 ~ FU2-16: Frequency Jump

FU2▶ Jump freq 10 --- No ---	10	0
---------------------------------	-----------	----------

Factory Default: No **0**

FU2▶ jump lo 1 11 10.00 Hz	11	10.00
-------------------------------	-----------	--------------

Factory Default: 10.00 Hz **10.00**

FU2▶ jump Hi 1 12 15.00 Hz	12	15.00
-------------------------------	-----------	--------------

Factory Default: 15.00 Hz **15.00**

-
-
-

FU2▶ jump lo 3 15 30.00 Hz	15	30.00
-------------------------------	-----------	--------------

Factory Default: 30.00 Hz **30.00**

FU2▶ jump Hi 3 16 35.00 Hz	16	35.00
-------------------------------	-----------	--------------

Factory Default: 35.00 Hz **35.00**

To prevent undesirable resonance and vibration on the structure of the machine, this function locks out the potential resonance frequency from occurring. Three different jump frequency ranges may be set. This avoidance of frequencies does not occur during accelerating or decelerating. It only occurs during continuous operation.

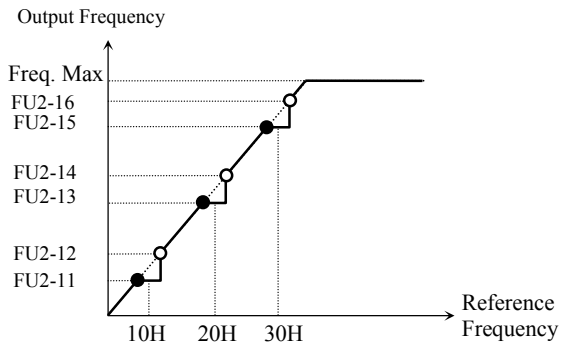

[Frequency Jump]

Note: When the reference frequency is set between the jump frequency low/high limit, it follows the low limit frequency, marked by “•”.

Note: If jump range 1 and range 2 are overlapped, lower freq. will become a low limit.

Note: Jump freq. is ignored during Accel/Decel.

FU2-20: Power ON Start Selection

FU2▶ Power-on run 20 No	20	0
----------------------------	-----------	----------

Factory Default: No **0**

If FUN-20 is set to ‘No’, turn the terminal off and turn on to restart the inverter even though the FX/RX signal is ON. If FUN-20 is set to ‘Yes’, the inverter will restart after power is restored. If the motor is rotating by inertia at the time power is restored, the inverter may trip. To avoid this trip, use ‘Speed Search’ function by setting bit 4 to ‘1’. If Speed search is not selected, inverter shows normal V/F pattern at acceleration.

CAUTION

Particular attention must be directed to this function as motor starts to run suddenly upon applying AC input power. Otherwise, it may result in personal damage.

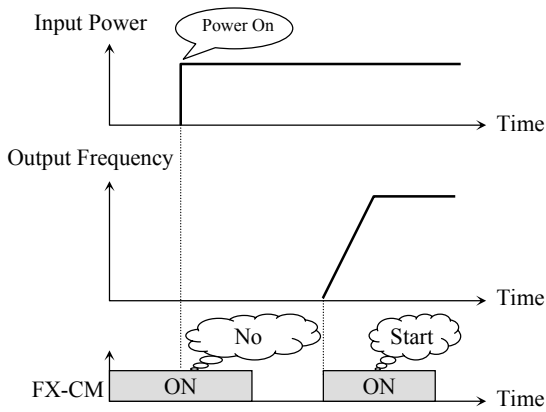

[Power ON Start: 'No']

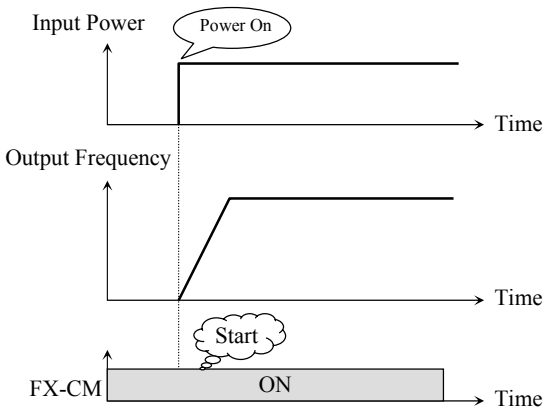

[Power ON Start: 'Yes']

Note: In case of using 'Power ON Start' to 'Yes', make sure to utilize appropriate warning notices to minimize the potential for injury or equipment damage.

FU2-21: Restart After Fault Reset

FU2▶ RST restart	21	0
21 No		

Factory Default: No **0**

If FU2-21 is set to 'No', restart the inverter by cycling the FX or RX terminal to CM terminal after the fault has been reset.
 If FU2-21 is set to 'Yes', inverter will restart after the RST (reset) terminal has been reset a fault. If the motor is rotating by inertia at the time power is restored, the inverter may trip. To avoid this trip, use 'Speed Search' function by setting bit 2 to 'xx1x'.

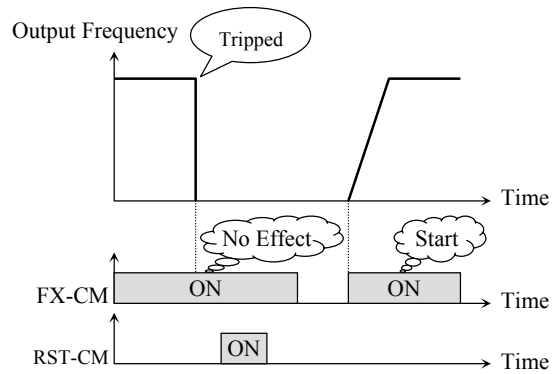

[Reset restart: 'No']

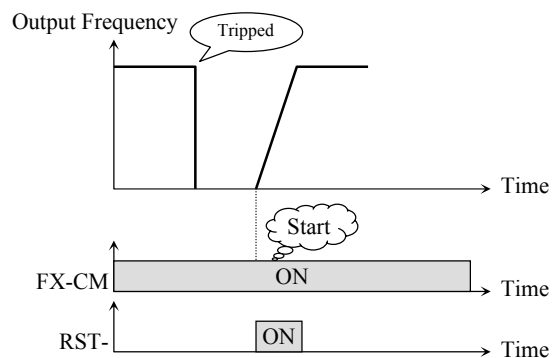

[Reset restart: 'Yes']

CAUTION

Particular attention must be directed to this function as motor starts to run suddenly after the fault is reset. Otherwise, it may result in personal damage.

FU2-22: Speed Search Selection (Bit Set)
 FU2-23: P Gain During Speed Search
 FU2-24: I Gain During Speed Search

FU2▶Speed Search 22 0000	22	0000
----------------------------------	-----------	-------------

Factory Default: 0000 **0000**

FU2▶ SS P-gain 23 200	23	200
-------------------------------	-----------	------------

Factory Default: 200 **100**

FU2▶ SS I-gain 24 500	24	500
-------------------------------	-----------	------------

Factory Default: 500 **200**

This function is used to permit automatic restarting after Power ON, Fault Reset, and Instant Power Failure without waiting for the motor free run to stop. The speed search gain should be set after considering the inertia moment (GD^2) and magnitude of torque of the load. FU2-46 [Load Inertia] must be set at the correct value to make this function operate correctly.

FU2-22 [Speed Search Select]

Setting Range (bit)				Description
4 th	3 rd	2 nd	1 st	
0	0	0	0	Speed search function does not work.
0	0	0	1	Speed search during Accelerating
0	0	1	0	Speed search during Restart after Fault Reset (FU2-21)
0	1	0	0	Speed search during Restart after Instant Power Failure.
1	0	0	0	Speed search during Power ON start (FU2-20) is set to "Yes".

When FU2-22 is set to '1111', Speed Search works for all conditions.

FU2-23 [P Gain] is the proportional gain used for speed search. Set this value according to load inertia set in FU2-46.

FU2-24 [I Gain] is the Integral gain used for speed search. Set this value according to load inertia set in FU2-46.

Caution: If I gain is set too high, Overshoot may occur, leading to OV Trip. In this case, reduce I Gain value.

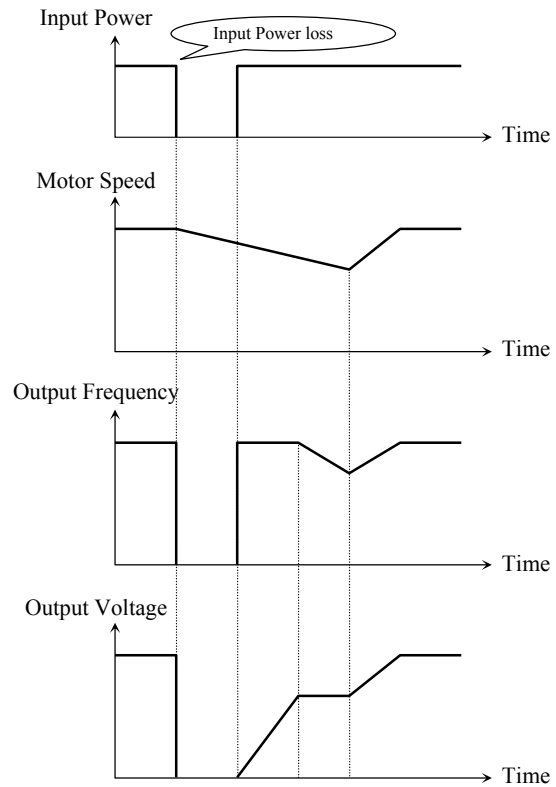

[Speed Search Operation]

FU2-25: Number of Auto Retry
FU2-26: Delay Time Before Auto Retry

FU2▶Retry number 25	25	0
------------------------	----	---

Factory Default: 0 0

FU2▶Retry delay 26 1.0 sec	26	1.0
-------------------------------	----	-----

Factory Default: 1.0 sec 1.0

This function is used to allow the inverter to reset itself for a selected number of times after FU2-26 elapses when inverter is tripped. If trip more than FU2-23 occur, inverter shuts down the output and displays a trip message. If the trip persists after FU2-26, number of trip is increased and Auto restart function is disabled. For example, FU2-25 [Retry number] is 1 with FU2-26 [Retry delay] set to 10 sec, if trip persists over 10 seconds and then is reset (cleared), Auto restart is not performed. Inverter may be tripped out in Motor Free-run status when this function is issued. To avoid it, use the speed search function. Set FU2-22 to 'xx1x'. See FU2-22 ~ FU2-24.
 Disabled when a low voltage (LV) trip, inverter disable (BX) or Arm short occurs.

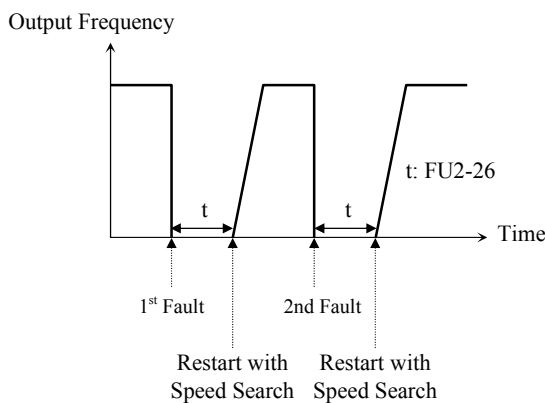

Note: Inverter decreases the retry number by one as a fault occurs. If trip does not occur after restarting for 30 seconds, the inverter increases the retry number by one and maximum number is limited by the value set in FU2-25.

⚠ CAUTION

Particular attention must be directed to this function as motor restarts automatically after the fault is reset. Otherwise, it may result in personal damage.

FU2-40: Motor Capacity Selection
FU2-41: Number of Motor Pole
FU2-42: Rated Motor Slip
FU2-43: Rated Motor Current
FU2-44: No Load Motor Current
FU2-45: Motor Efficiency
FU2-46: Load Inertia

If users do not set these values, inverter will use factory default values.

FU2▶Motor select 40 5.5 kW	40	4
-------------------------------	----	---

Factory Default: 5.5 kW 4
 (This value is set automatically according to the inverter model.)

This parameter sets the motor capacity. FU2-42 [Rated Motor Slip], FU2-43 [Rated Motor Current], FU2-44 [No Load Motor Current], FU2-62 [Stator Resistance], FU2-63 [Rotor Resistance], and FU2-64 [Leakage Inductance] are automatically changed according to motor capacity.
 If FU2-44 [Motor No-load Current] is not correct, run the inverter without the load in V/F mode and check the current at the constant run state and enter this value to FU2-44 [No load current].

FU2▶ Pole number 41 4	41	4
--------------------------	----	---

Factory Default: 4 4

This is used to display the motor speed. If you set this value to 2, inverter will display 3600 rpm instead of 1800rpm at 60Hz output frequency. (See motor nameplate) When motor pole number is more than 4, select an inverter one rating higher than that of the motor because motor rated current is large.

FU2▶ Rated-Slip 42 2.34 Hz	42	2.34
-------------------------------	----	------

Factory Default: 2.34 Hz 2.34
 (This value is set according to the motor capacity set in FU2-40)

This is used in ‘Slip Compensation’ control. If you set this value incorrectly, motor may stall during slip compensation control. (See motor nameplate)

FU2▶ Rated-Curr 43	19.7 A	43	19.7
-----------------------	--------	-----------	-------------

Factory Default:	19.7 A	19.7
(This value is set according to the motor capacity set in FU2-40)		

This is very importance parameter that must be set correctly. This value is referenced in many of other inverter parameters. (See motor nameplate)

FU2▶ No-load-Curr 44	6.6 A	44	6.6
-------------------------	-------	-----------	------------

Factory Default:	6.6 A	6.6
(This value is set according to the motor capacity set in FU2-40)		

This parameter is only displayed when ‘Slip Compen’ is selected in FU2-60 [Control Method].

If this value is not right, check the current after operating in V/F mode without load connected and enter that current value.

Note: make sure to use correct value for FU2-44 [Motor No-load Current]. Otherwise, Sensorless performance may be degraded.

Note: Preset motor parameters may differ with user motors. In this case, enter the nameplate value of your motor to the corresponding parameters. If motor rating exceeds inverter capacity, unsatisfactory control performance may result because all other control parameters follow inverter capacity.

FU2▶ Efficiency 45	86 %	45	86
-----------------------	------	-----------	-----------

Factory Default:	86 %	86
(This value is set according to the motor capacity set in FU2-40)		

This value is used for calculating the output wattage when FU2-72 is set to ‘Watt’.

FU2▶ Inertia rate 46	0	46	0
-------------------------	---	-----------	----------

Factory Default:	0	0
------------------	---	----------

This parameter is used for sensorless control, Minimum Accel/Decel, Optimum Accel/Decel and Speed search. For better control performance, this value must be set correctly. Install a DB unit or regenerative converter to improve the performance.

Set ‘0’ for loads that has load inertia less than 10 times that of motor inertia.

Set ‘1’ for loads that have load inertia about 10 times that of motor inertia.

Motor rated slip freq [Hz]=(Rated input freq. [Hz] – (Motor rpm * P/120))
P: Number of motor poles

(Ex) In the case of 60Hz, 4 pole, 1730 rpm motor
Motor rated slip freq [Hz]= (60[Hz]-(1750[rpm] * 4/120))
=60[Hz]-58.67[Hz]=1.33[Hz]

FU2-47: Gain for Motor Speed Display

FU2▶ RPM factor 47	100 %	47	100
-----------------------	-------	-----------	------------

Factory Default:	100 %	100
------------------	-------	------------

This code is used to change the motor speed display to rotating speed (r/min) or mechanical speed (m/min). The display is calculated by following equation.

Rotating speed (r/min) = 120 * F / P,
Where, F=Output frequency, P= motor pole number

Mechanical speed (m/min) = Rotating speed * Motor RPM Display Gain [FU2-47]

FU2-48: Carrier Frequency

FU2▶ Carrier freq 48	5.0 kHz	48	5.0
-------------------------	---------	-----------	------------

Factory Default:	5.0 kHz	5.0
------------------	---------	------------

Code	LCD Display	Factory Default	Setting range	
FU2-48	Carrier freq	5.5 ~ 22 kW	5 [kHz]	0.7 ~ 15 [kHz]
		30 kW		0.7 ~ 10 [kHz]
		37 ~ 75 kW	4 [kHz]	0.7 ~ 4 [kHz]
		90 ~ 280 kW	3 [kHz]	0.7 ~ 3 [kHz]
		315 ~ 450 kW	2 [kHz]	0.7 ~ 2 [kHz]

This parameter affects the audible sound of the motor, noise emission from the inverter, inverter temperature, and leakage current. If the ambient temperature where the inverter is installed is high or other equipment may be affected by potential inverter noise, set this value lower. If set above 10kHz, reduce the rated current by 5% per 1kHz. Setting Carrier frequency set below 1.5 [kHz] when the FU2-60 [Control mode selection] is set to Sensorless, the control performance could be weakened.

Caution: FU2-48 [Carrier freq] setting range varies as inverter capacity.

FU2-49: PWM Mode Selection (to reduce noise or leakage current by changing PWM method)

FU2▶ PWM Select	49	0
49 Normal 1		

Factory Default: Normal 1 **0**

Noise and leakage current can be reduced without changing carrier frequency by decreasing switching cycle.

“Normal 1” is the general PWM method while “Normal 2” is the PWM method when low noise (low motor sound) is needed at motor starting. When Normal 1 is selected at motor starting, inverter changes switching frequency from low to set value. When Normal 2 is selected, inverter starts to operate at the set-value. “Low Leakage” is used to reduce Leakage current by decreasing switching cycle.

No	I/O-86,-87,-88 setting	Description
0	Normal 1	Operation via basic Carrier (switching) frequency.
1	Normal 2	Operation via fixed Carrier (switching) frequency.
2	Low Leakage	Change (Carrier) switching frequency pattern to reduce leakage current.

Caution: Reducing the Carrier frequency may increase noise.

Caution: When 2 {Low leakage} is selected while carrier frequency is set lower than 2.0 kHz in FU2-48, FU2-48 value is automatically set to 2.0kHz.

FU2-60: Control mode selection

FU2▶ Control mode	60	0
60 V/F		

Factory Default: V/F **0**

Selects the control mode of the inverter

FU2-40 setting	LCD Display	Description
0	V/F	V/F Control
1	Slip compensation	Slip compensation
2	Sensorless	Sensorless vector control speed operation

V/F control:

This parameter controls the voltage/frequency ratio constant. It is recommended to use the torque boost function when a greater starting torque is required. Related function: FU1-67~69 [Torque boost]

Slip compensation:

This function is used to maintain constant motor speed. To keep the motor speed constant, the output frequency varies within the limit of slip frequency set in FU2-42 according to the load current. For example, when the motor speed decreases below the reference speed (frequency) due to a heavy load, the inverter increases the output frequency higher than the reference frequency to increase the motor speed. The inverter increases or decreases the output by delta frequency shown below.

$$\text{Delta freq (Slip Comp. Freq.)} = \text{Motor Rated slip} * (\text{Output current} - \text{Motor No load current}) / (\text{Motor rated current} - \text{Motor No load current})$$

$$\text{Output freq} = \text{Reference freq} + \text{Delta freq}$$

FU2-40~46 [Motor parameters] is automatically determined by FU2-40 [Motor selection]. Most suitable motor capacity corresponding inverter capacity is set as factory setting, but the following parameters can be adjusted if necessary.

FU2-40~46 [Motor related parameters for Slip Compensation]

Code	LCD Display	Description
FU2-40	Motor select	Select motor capacity
FU2-42	Rated-Slip	Motor rated slip (Hz)
FU2-43	Rated-Curr	Motor rated current (rms)
FU2-44	Noload-Curr	Motor no load current (rms)
FU2-45	Efficiency	Motor efficiency (%)
FU2-46	Inertia rate	Motor inertia rate

Note: Incorrectly set FU2-44 [Motor No-load Current] value may weaken the Sensorless control.

Sensorless (Sensorless vector speed control) operation:

Use it when 1) high starting torque is needed at low speed 2) load fluctuation is high 3) rapid response is needed. To use this function, set FU2-40~46 [Motor parameters] and FU2-60 [Control mode select] properly.

If not using LG 220V/440V Class motor: Set “Yes” in FU2-61 [Auto tuning] first before using this control.

Related parameters: FU2-40~46, FU2-60, FU2-62~66

Code	LCD display	Parameter
FU2-62	RS	Stator resistance
FU2-63	Lsigma	Leakage inductance
FU2-65	SL P-gain	Sensorless P gain
FU2-66	SL I-gain	Sensorless I gain

[Guide for Optimal Use of Sensorless Vector Control]

For optimal use of the sensorless control, the following conditions should be met. If one of the following conditions is not satisfied, the inverter may malfunction due to insufficient torque, irregular rotation, or excessive motor noise. In this case, it is recommended to use V/F control.

Use a motor capacity that is equal to or one horsepower level lower than the inverter capacity.

Two types of motor parameters can be set for one inverter, but use only one type for sensorless control.

Use a LG 220V/440V(0.4kW~30kW) class motor. If other makers’ motor or a LG 220V/380V dual rating motor is used, utilize the auto tuning feature in FU2-61 [Auto tuning] before starting.

Set appropriate values for the electronic thermal function, the overload limit function and the stall prevention. The set values should exceed 100% of the rated motor current.

When DRV-04 [Frequency Mode] is set to “V1”, “V1S”, “I”, or “V1+I”, wiring should be conducted to eliminate potential noise influence with the frequency reference.

Pole number of the motor should be 2 pole, 4 pole, or 6 pole.

The distance between the inverter and the motor should not exceed 100m (328 ft).

[Cautions on Sensorless Vector Control]

Forced-cooling should be used for the motor when the average operating speed is under 20Hz and more than 100% load is used constantly.

Motor may rotate 0.5% faster than the maximum speed if the motor temperature does not reach normal operating temperature.

Utilize the auto-tuning feature when the motor reaches normal temperature (average temperature where the motor normally operates).

Output torque may be reduced when an output filter option is used between the inverter and the motor.

Overcurrent trip may occur if FU2-62 [Stator

resistance] is set twice more than auto-tuned value.

[Detail Tuning Method for Sensorless Vector Control]

Adjust the FU2-44 [No Load Motor Current (RMS)] value larger or smaller by 5% units if the current is larger or smaller than that of V/F control under small load.

Adjust the FU2-42 [Rated Motor Slip] value larger or smaller by 5% units if the speed is faster or slower than that of V/F control with rated load.

FU2-61~63: Auto tuning

FU2▶ Auto tuning 61 NO	61	0
---------------------------	-----------	----------

Factory Default: NO **0**

All of the motor parameters can be tuned by setting “YES (1)”. Auto tuning is deactivated when “No (0)” is selected.

[Parameter display based on Inverter capacities]

Class	Inverter	Motor parameters			
		Rs	Lsigma	Ls	Tr
200V	5.5[kW]	X.XXX ohm	X.XX mH	X.XX mH	XXX ms
	7.5[kW] ~ 30[kW]	X.X mohm	X.XXX mH	X.XX mH	XXX ms
400V	5.5[kW] ~ 15[kW]	X.XXX ohm	X.XX mH	X.X mH	XXX ms
	18.5[kW] ~ 30[kW]	X.X mohm	X.XXX mH	X.XX mH	XXX ms

Note: Unit is not displayed on 7-Segment keypad.

The auto tuning function automatically measures the motor parameters needed for control selected in FU2-60 [Control mode] such as stator resistance, rotor resistance, leakage inductance, no-load current and Encoder feedback frequency.

The rated current, voltage, efficiency and slip described in the motor nameplate should be entered before performing auto tuning. If efficiency is not indicated on the nameplate, use the preset value.

FU2-64: Pre-excitation Time

FU2▶ PreExTime 64 1.0 sec	64	1.0
------------------------------	-----------	------------

Factory Default: 1.0 sec **1.0**

When the operation command (FWD, REV) is issued, the inverter conducts pre-exciting automatically for the time specified by this parameter.

After FU2-64 [Pre-excitation Time] elapses the inverter starts normal operation shown in the following graph.

Code	LCD display	Default	Setting range
FU2-64	PreExTime	1 [sec]	0 ~ 60 [sec]

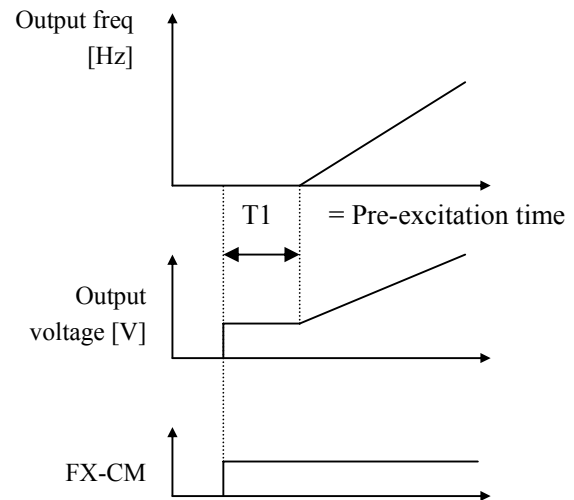

FU2-65: P Gain for Sensorless Control
FU2-66: I Gain for Sensorless Control

FU2▶ SL P-gain 65 1000	65	1000
Factory Default: 1000		1000

SL P-gain is the proportional gain of speed controller. If this value is set high, you can get fast speed response characteristic. However, if this value is set too high, the steady state characteristics may become unstable. Set the proper value for your application.

FU2▶ SL I-gain 66 100	66	100
Factory Default: 100		100

SL I-gain is the integral gain of speed controller. If this value is set low, you can get better transient response characteristic and steady state characteristic. However, if this value is set too low, there may be an overshoot in speed control.

Note: The response time of a system is affected by the load inertia. For better control performance, set the FU2-46 [Load Inertia] correctly.

FU2-67: Manual/Auto Boost Selection
FU2-68: Torque Boost in Forward Direction
FU2-69: Torque Boost in Reverse Direction

FU2▶ Torque boost 67 Manual	67	0
Factory Default: Manual		0

FU2▶ Fwd boost 68 2.0 %	68	2.0
Factory Default: 2.0 %		2.0

FU2▶ Rev boost 69 2.0 %	69	2.0
Factory Default: 2.0 %		2.0

This function is used to increase the starting torque at low speed by increasing the output voltage of the inverter. If the boost value is set too high than required, it may cause the motor flux to saturate, causing over-current trip. Increase the boost value when there is excessive distance between inverter and motor.

[Manual Torque Boost]

When FU2-67 [Manual/Auto torque boost select] is set to “Manual”, FU2-68 [Forward torque boost] and FU2-69 [Reverse torque boost] set values are applied. FU2-68 [Forward torque boost] is used for Forward rotation and FU2-69 [Reverse torque boost] is used for Reverse rotation.

Code	LCD display	Default	Setting range
FU2-67	Torque boost	Manual	Manual/Auto
FU2-68	Fwd boost	2.0 [%]	0~15 [%]
FU2-69	Rev boost	2.0 [%]	0~15 [%]

Note: The torque boost value is to be set as the percentage of inverter rated voltage.

Note: When FU1-40 [Volts/Hz Pattern] is set to ‘User V/F’, FU2-67~69 [Torque boost] is ignored.

Note: Do not set the torque boost too high. Otherwise, motor may be over-magnetized.

Note: Increase this value when torque shortage happens or inverter-motor wiring is distant. If this value is set too high, Overcurrent trip may be triggered.

Chapter 6 - Parameter Description [FU2]

Note: It is possible to occur No Motor Trip in case that the torque boost value is 0 when DC Start is operated.

[Auto Torque Boost]

When FU2-67 [Manual/Auto torque boost select] is set to “Auto”, inverter outputs high starting torque by automatic boosting according to the load characteristic.

Note: Auto torque boost is only applied to the 1st motor.

Only Manual torque boost is available for the 2nd motor.

Note: Auto torque boost is not available when FU2-60 [Control Mode] is set to ‘Sensorless’.

Note: Conduct Auto tuning in FU2-61 [Auto tuning] first to use Auto torque boost effectively.

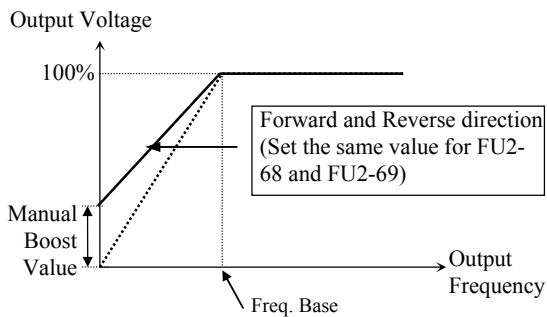

[Constant Torque Loads: Conveyor, Moving Equip. etc.]

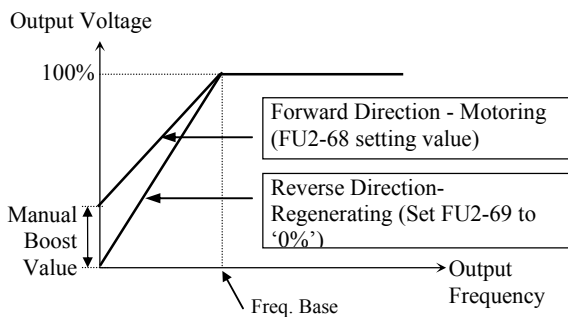

[Ascending and Descending Loads: Parking, Hoist etc.]

Related Functions: FU1-40 [Volts/Hz Pattern]
FU2-60 [Control Mode selection]

FU2-80: Power On Display

FU2▶PowerOn disp	80	0
80	0	

Factory Default:	0	0
------------------	---	----------

This code selects the parameter to be displayed first on keypad (DRV-00) when the power is turned on.

Setting Range	Description
0	DRV-00 [Command Frequency]
1	DRV-01 [Acceleration Time]
2	DRV-02 [Deceleration Time]
3	DRV-03 [Drive Mode]
4	DRV-04 [Frequency Mode]
5	DRV-05 [Step Frequency 1]
6	DRV-06 [Step Frequency 2]
7	DRV-07 [Step Frequency 3]
8	DRV-08 [Output Current]
9	DRV-09 [Motor Speed]
10	DRV-10 [DC link Voltage]
11	DRV-11 [User Display selected in FU2-73]
12	DRV-12 [Fault Display]

FU2-81: User display selection

FU2▶ User Disp	81	0
81	Voltage	

Factory Default:	0	0
------------------	---	----------

Related Function: DRV-11 [User display selection]

Select the display as shown below.

Setting	FU2-81	Name	Description
0	Voltage	Output voltage	Display output voltage of the inverter (Factory setting)
1	Watt	Output power	Display output power of the inverter

Note: The displayed value of “Watt” is approximate value.

FU2-82: Software Version

FU2▶ S/W Version 82 Ver X.X	82	XX
--------------------------------	-----------	-----------

Factory Default: Ver. X.X **XX**

Displays the software version. This will vary depending on software version integrated.

FU2-83, 84, 85: Last Trip Time, On-time, Run-time

FU2▶ LastTripTime 83 0:00:00:00:00	83	00.00
---------------------------------------	-----------	--------------

Factory Default: 0:00:00:00:00 **00.00**

Displays time elapsed after last trip occurs.

Note: it is reset automatically upon trip occurs.

FU2▶ On-time 84 0:00:00:00:00	84	00.00
----------------------------------	-----------	--------------

Factory Default: 0:00:00:00:00 **00.00**

Displays time after Power is turned ON.

Note: it is not reset automatically.

FU2▶ Run-time 85 0:00:00:00:00	85	00.00
-----------------------------------	-----------	--------------

Factory Default: 0:00:00:00:00 **00.00**

Displays time for inverter to be run.

Note: it is not reset automatically.

**FU1-83~85 display → X : XX : XX : XX : XX
(Year:Month:Day:Hour:Minute)**

FU2-87: PowerSet

FU2▶ PowerSet 87 100	87	
-------------------------	-----------	--

Factory Default: 100% **100**

Used to adjust the current inverter output power and FU1-54 [KiloWattHour].

FU2-90: Parameter Display

FU2▶ Para. disp 90 Default	90	1
-------------------------------	-----------	----------

Factory Default: Default **1**

It is used to change the parameters to be viewed.

No	FU2-90 Set data	Description
0	Default	Displays basic parameters. (factory default)
1	All Para	Displays all parameters.
2	Diff Para	Displays parameters set differently from factory setting.

**FU2-91: Parameter Read
FU2-92: Parameter Write**

FU2▶ Para. read 91 --- No ---

Factory Default: No

FU2▶ Para. write 92 --- No ---

Factory Default: No

This is useful for programming multiple inverters to have same parameter settings. The LCD keypad can read (upload) the parameter settings from the inverter memory and can write (download) them to other inverters. This function is only available with LCD keypad.

Note: When FU2-91, 92 is used, motor parameters such as FU2-40~46, FU2-62~63 will be initialized. Perform Auto-tuning first before using Sensorless mode.

Note: Perform FU2-95 [Parameter save] first before FU2-91 [Parameter Read].

1) Set FU2-91 to “Yes” and press Enter key to read the parameters.

```
FU2▶ Para. read
91 --- Yes ---
```

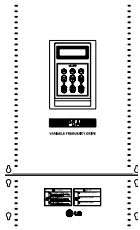

2) Take the LCD keypad out.

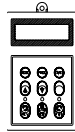

```
FU2▶ Para. write
92 --- Yes ---
```

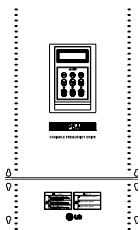

3) Install it to the subject inverter and set FU2-92 to “Yes” and press Enter to download the parameters.

FU2-93: Parameter Initialize

```
FU2▶ Para. init
93 No 93 0
```

Factory Default: No **0**

This is used to initialize parameters back to the factory default values. Each parameter group can be initialized separately.

Note: Set FU2-40~46 [Motor parameters] again after this function.

Note: Parameter initialize cannot clear trip information. Instead, use FU2-06 [Erase trips].

Setting Range	Description
No	Displayed after initializing is finished.
All Groups	All parameter groups initialized to factory default value.
DRV	Only Drive group initialized.
FU1	Only Function 1 group initialized.
FU2	Only Function 2 group initialized.
I/O	Only Input/Output group initialized.
EXT	Only External group initialized.
COM	Only Communication group initialized.
APP	Only Application group initialized.

FU2-94: Parameter Lock

```
FU2▶ Para. lock
94 0 94 0
```

Factory Default: 0 **0**

This function is used to lock the parameters from being changed. When the parameters are locked, the display arrow changes from solid to dashed line. The lock and unlock code is ‘12’.

FU2-95: Parameter Save (Manual Save)

```
FU2▶ Para. save
95 No 95 0
```

Factory Default: 0 **0**

When FU2-95 is set to “Yes”, the changed parameter value is saved into memory.

FU2-99: Return Code (7-Segment Keypad)

99 **1**

Factory Default: **1**

This code is used to exit a group when using a 7-segment keypad. After pressing **PROG/ENT** key, set the value to ‘1’ and press the **PROG/ENT** key again to exit.

6.4 Input/Output Group [I/O]

I/O-00: Jump to Desired Code

I/O▶ Jump code
00 1

Factory Default: 1

Jumping directly to any parameter code can be accomplished by entering the desired code number. This code is available only with LCD keypad.

I/O-01 ~ I/O-05: Analog Voltage Input (V1) Signal Adjustment

This is used to adjust the analog voltage input signal when the frequency is referenced by the control terminal 'V1'. This function is applied when DRV-04 is set to 'V1', 'V1S', or 'V1+I'. Reference frequency versus Analog voltage input curve can be made by four parameters of I/O-02 ~ I/O-04. User-selected Unit appears in [**]. To change the unit, more than one in APP-02 [PID operation selection] and APP-80 [Ext. PID operation selection] is set to "Yes" and then select the desired unit Percent, Bar, mBar, kPa, and Pa among in I/O-86 [V1 user unit selection].

Code	Factory Default	Setting Range
I/O-01	10 [msec]	0~9999 [msec]
I/O-02	0 [V]	0 ~ 12 [V]
I/O-03	0 [Hz]	0 ~ Max Freq
	0 [**]	0 ~ 100.00 [**]
I/O-04	10 [V]	0 ~ 12 [V]
I/O-05	60 [Hz]	0 ~ Max Freq
	0 [**]	0 ~ 100.00 [**]

I/O▶ V1 filter
01 10 ms

01 **10**

Factory Default: 10 ms **10**

This is the filtering time constant for V1 signal input. Increase this value if the V1 signal is affected by noise causing unstable operation of the inverter. Increasing this value makes response time slower.

I/O▶ V1 volt x1
02 0.00 V

02 **0.00**

Factory Default: 0.00 V **0.00**

This is the minimum voltage of the V1 input at which inverter outputs minimum frequency.

I/O▶ V1 freq y1
03 0.00 Hz

03 **0.00**

Factory Default: 0.00 Hz **0.00**

This is the inverter output minimum frequency (or target value) when there is the minimum voltage (I/O-02) on the V1 terminal.

I/O▶ V1 volt x2
04 0.00 V

04 **10.00**

Factory Default: 10.00 V **10.00**

This is the maximum voltage of the V1 input at which inverter outputs maximum frequency.

I/O▶ V1 freq y2
05 60.00 Hz

05 **60.00**

Factory Default: 60.00 Hz **60.00**

This is the inverter output maximum frequency (or target value) when there is the maximum voltage (I/O-03) on the V1 terminal.

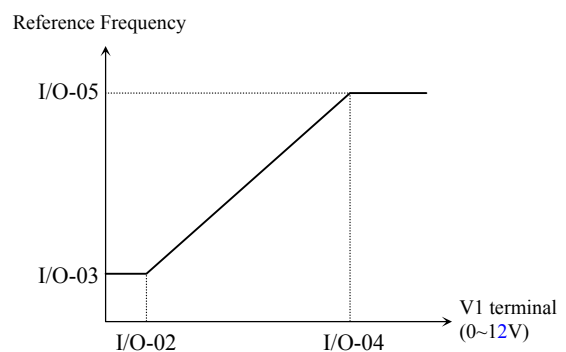

[Reference Frequency vs Analog Voltage Input (0 to 12V)]

Chapter 6 - Parameter Description [I/O]

I/O-06 ~ I/O-10: Analog Current Input (I) Signal Adjustment

This is used to adjust the analog current input signal when the terminal 'I' references the frequency. This function is applied when DRV-04 is set to 'I', or V1+I'. Reference frequency versus Analog current input curve can be made by four parameters of I/O-07 ~ I/O-10. User-selected Unit appears in [**]. To change the unit, more than one in APP-02 [PID operation selection] and APP-80 [Ext. PID operation selection] is set to "Yes" and then select the desired unit Percent, Bar, mBar, kPa, and Pa among in I/O-87 [I user unit selection].

Code	Default	Setting	Code	Default	Setting
I/O-07	4 [mA]	0 ~ 20 [mA]	I/O-09	20[mA]	0 ~ 20 [mA]
I/O-08	0 [Hz]	0 ~ Max freq	I/O-10	60[Hz]	0 ~ Max freq
	0 [**]	0~100.0 0[**]		0 [**]	0~100.0 0[**]

I/O▶ I filter
06 10 ms **06** **10**

Factory Default: 10 ms **10**

This is the filtering time constant for 'I' signal input. If the 'I' signal is affected by noise causing unstable operation of the inverter, increase this value. Increasing this value makes response time slower.

I/O▶ I curr x1
07 4.00 mA **07** **4.00**

Factory Default: 4.00 mA **4.00**

This is the minimum current of the 'I' input at which inverter outputs minimum frequency.

I/O▶ I freq y1
08 0.00 Hz **08** **0.00**

Factory Default: 0.00 Hz **0.00**

This is the inverter output minimum frequency (or target value) when there is minimum current (I/O-07)

input on the 'I' terminal.

I/O▶ I curr x2
09 20.00 mA **09** **20.00**

Factory Default: 20.00 mA **20.00**

This is the maximum current of the 'I' input at which inverter outputs maximum frequency.

I/O▶ I freq y2
10 60.00 Hz **10** **60.00**

Factory Default: 60.00 Hz **60.00**

This is the inverter output maximum frequency (or target value) when there is the maximum current input (I/O-09) on the 'I' terminal.

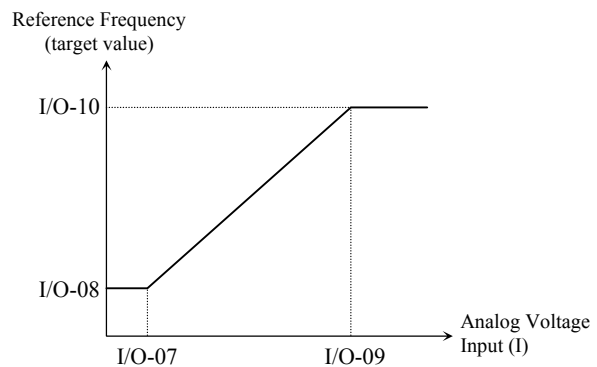

[Reference Frequency vs Analog Current Input (4 to 20mA)]

I/O-11~16: Frequency command setting via pulse (A0/B0)

I/O▶ P pulse set 11 (A)	11	1
----------------------------	-----------	----------

Factory Default: (A)	1
----------------------	----------

I/O▶ P filter 12 10 msec	12	10
-----------------------------	-----------	-----------

Factory Default: 10 msec	10
--------------------------	-----------

I/O▶ P pulse x2 15 10.00 KHz	15	10
---------------------------------	-----------	-----------

Factory Default: 10.0 KHz	10.0
---------------------------	-------------

I/O▶ P pulse y2 16 60.00 Hz	16	60.00
--------------------------------	-----------	--------------

Factory Default: 60.00 Hz	60.00
---------------------------	--------------

Set the frequency command from control terminal A0 or B0. It is settable when DRV-04 [Frequency mode] is set to "Pulse".

User-selected Unit appears in [**]. To change the unit, more than one in APP-02 [PID operation selection] and APP-80 [Ext. PID operation selection] is set to "Yes" and then select the desired unit Percent, Bar, mBar, kPa, and Pa among in I/O-88 [Pulse Input user unit selection].

Code	Factory setting	Setting range
I/O-11	(A)	(A), (A)+(B)
I/O-12	10 [msec]	0 ~ 9999 [msec]
I/O-13	0 [KHz]	0 ~ 10 [KHz]
I/O-14	0 [Hz]	0 ~ Max frequency
	0 [**]	0 ~ 100.00[**]
I/O-15	10 [KHz]	10 ~ 100 [KHz]
I/O-16	60 [Hz]	0 ~ Max frequency
	0 [**]	0 ~ 100.00[**]

Note: Do not apply pulse to both A0, B0 terminals when I/O-12 set value is A.

Pulse information

T/N	Default	Setting range
A0	A Pulse Input	High: +3~+12V Max Low: +2.5V Max Max Input Freq.: 100KHz
B0	B Pulse Input	High: +3~+12V Max Low: +2.5V Max Max Input Freq.: 100KHz

Note: Use Open Collector type encoder for Pulse input with Max. 12 V Power supply.

Code	LCD Display	Description
I/O-11	P Pulse Set	Set one of the frequency setting input method either A or A+B.
I/O-12	P filter	Set the embedded filter constant for P Pulse input.
I/O-13	P Pulse x1	Set the Minimum frequency for P Pulse input.
I/O-14	P freq y1	Set the output frequency corresponding to P Pulse input minimum frequency (I/O-13).
	P [**] y1	Set the target value corresponding to P Pulse input minimum frequency (I/O-13)
I/O-15	P Pulse x2	Set the Maximum frequency for P Pulse input.
I/O-16	P freq y2	Set the output frequency corresponding to P Pulse input Maximum frequency (I/O-15).
	P [**] y2	Set the target value corresponding to P Pulse input maximum frequency (I/O-15)

Note: Increase filter time constant when the noise interference deteriorates stable operation. Increasing that makes response time slower.

Note: When setting P Pulse Input Min/Max Freq. via motor encoder, set the value for encoder pulse as the following;

EX) To give 60Hz (1800 rpm) command from 1000 Pulse encoder

I/O-15 [Max Freq of P Pulse Input]=Rated rpm/60 sec * Number of Encoder Pulse
 = 1800 [rpm]/60[sec]*1000=3000Hz,
 Therefore, set I/O-15 to 3.0KHz

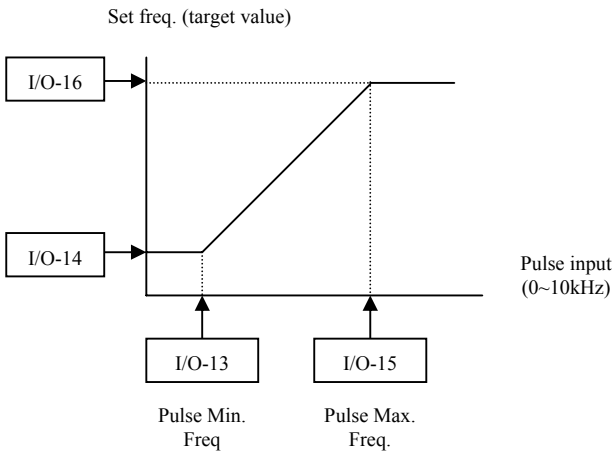

I/O-17, 18, 19: Criteria for Analog Input Signal Loss

I/O▶ Wire broken 17 None	17	0
-----------------------------	-----------	----------

Factory Default: None **0**

I/O▶ Lost command 18 None	18	0
------------------------------	-----------	----------

Factory Default: None **0**

I/O▶ Time out 19 1.0 sec	19	1.0
-----------------------------	-----------	------------

Factory Default: 1.0 sec **1.0**

This is to set the criteria for analog input signal loss when DRV-04 [Frequency Mode] is set to 'V1', 'V1S', 'I', 'V1+I' or 'Pulse'. However, for "V1+I", main speed is V1 so inverter does not respond when I signal is missing. Following table shows the setting value.

Setting Range	Description
None	Disabled.
half of x1	The inverter determines that the frequency reference is lost when the analog input signal is less than half of the minimum set value (I/O-02, I/O-07, I/O-13).
below x1	The inverter determines that the frequency reference is lost when the analog input signal is less than the minimum set value (I/O-02 or I/O-07, I/O-13).

I/O-18 [Operating method after loss of analog freq. command] selects the operation after determining the loss of frequency reference.

The following table shows the selection in I/O-18.

Setting Range	Description
None	Continuous operating after loss of frequency reference.
FreeRun	Inverter cuts off its output after determining loss of frequency reference.
Stop	Inverter stops by its Decel pattern and Decel time after determining loss of frequency reference.

When the analog input signal is lost, inverter displays the following table.

Setting Range	Description
LOV	Loss of analog input signal, V1
LOI	Loss of analog input signal, I
LOA	Loss of pulse reference frequency

I/O-19 [Time out] sets the waiting time before determining the loss of reference signal. Inverter waits to determine the loss of a reference signal until time-out.

Reference frequency can be viewed as Rpm when DRV-16 [Hz/Rpm Display] is set to "rpm".

**I/O-20~27: Programmable Digital Input Terminal
'M1, M2, M3', 'M4', 'M5', 'M6', 'M7', 'M8' Define**

I/O▶ M1 define 20 Speed-L	20	0
------------------------------	-----------	----------

Factory Default: Speed-L **0**

I/O▶ M2 define 21 Speed-M	21	1
------------------------------	-----------	----------

Factory Default: Speed-M **1**

I/O▶ M3 define 22 Speed-H	22	2
------------------------------	-----------	----------

Factory Default: Speed-H **2**

-
-
-

Programmable Digital input terminals can be defined for many different applications. The following table shows the various definitions for them.

Code	LCD display	Default	Setting
I/O-20	M1 define	SPEED-L	See the table below
I/O-21	M2 define	SPEED-M	
I/O-22	M3 define	SPEED-H	
I/O-23	M4 define	Reset	
I/O-24	M5 define	BX	
I/O-25	M6 define	JOG	
I/O-26	M7 define	FX	
I/O-27	M8 define	RX	

Note: BX is Emergency Stop key. Parameter setting is disabled when BX is ON.

Selection of M1, M2, M3 M4, M5, M6, M7, M8 in I/O-20~27

Setting Range	Description
Speed-L	Multi-step speed - Low
Speed-M	Multi-step speed - Mid
Speed-H	Multi-step speed - High
XCEL-L	Multi-accel/decel - Low
XCEL-M	Multi-accel/decel - Mid
XCEL-H	Multi-accel/decel - High
Dc-brake	DC injection braking during stop
2ndFunc	Exchange to 2 nd functions
Exchange	Exchange to commercial line
-Reserved-	Reserved for future use
Up	Up drive
Down	Down drive
3-Wire	3 wire operation
Ext Trip	External trip
Pre-heat	Motor Pre-heat function
iTerm Clear	Used for PID control
Open-loop	Exchange between PID mode and V/F mode
LOC/REM	Exchange between Drv-03, 04 and Drv-91, 92
Analog hold	Hold the analog input signal
XCEL stop	Disable Accel and Decel
P Gain2	Used for PID control
-Reserved-	Reserved for future use
Interlock1	Used for MMC operation
Interlock2	
Interlock3	
Interlock4	
Speed-X	Additional Step frequency selection
Reset	Reset
BX	BX (Emergency stop)
JOG	Jog
FX	Forward Run/Stop
RX	Reverse Run/Stop
Ana Change	Analog input Switch-over
Pre excite	Pre excitation.
Ext.PID Run	External PID Run/Stop

I/O-28: Terminal Input Status

I/O▶ In status 28 000000000000	28	0000
-----------------------------------	-----------	-------------

Factory Default: 000000000000 **0000**

This code displays the input status of control terminals M1-M8, P4-P6. P4, P5, P6 will be only displayed and used when the sub-board is installed.

[LCD Keypad Display]

Input T/M	P6	P5	P4	M8	M7	M6	M5	M4	M3	M2	M1
	10 bit	9 bit	8 bit	7 bit	6 bit	5 bit	4 bit	3 bit	2 bit	1 bit	0 bit
OFF status	0	0	0	0	0	0	0	0	0	0	0
ON status	1	1	1	1	1	1	1	1	1	1	1

I/O-29: Programmable Digital Input Terminal filter time constant

I/O▶ Ti Filt Num 29 15 ms	29	15
------------------------------	-----------	-----------

Factory Default: 15 ms **15**

Set the responsiveness of input terminals M1-M8 and P4-P6. It is effective when noise level is high. Increasing this will make response time slower and decreasing faster.

Note: Set it higher than 100msec at Inverter-commercial line exchange operation. This will be useful to prevent chattering and momentary malfunction.

I/O-30: Jog Frequency

I/O▶ Jog freq 30 10.00 Hz	30	10.00
------------------------------	-----------	--------------

Factory Default: 10.00 Hz **10.00**

This code sets the jog frequency. See I/O-31~42, DRV-05~ 07 for details.

I/O-31~42: Step Frequency 4, 5, 6, 7, 8, 9, 10, 11, 12, 13, 14, 15

I/O▶ Step freq-4 31 40.00 Hz	31	40.00
---------------------------------	-----------	--------------

Factory Default: 40.00 Hz **40.00**

I/O▶ Step freq-5 32 50.00 Hz	32	50.00
---------------------------------	-----------	--------------

Factory Default: 50.00 Hz **50.00**

[Speed-L, Speed-M, Speed-H, Speed-X]

By setting M1, M2, M3 terminals to 'Speed-L', 'Speed-M' and 'Speed-H' respectively, inverter can operate at the preset frequency set in DRV-05 ~ DRV-07 and I/O-20 ~ I/O-27.

The step frequencies are determined by the combination of M1, M2 and M3 terminals as shown in the following table.

Code	Step speed Frequency	Spd-X	Spd-H	Spd-M	Spd-L	JO G
DRV-00	S. Freq-0 (Zero Spd)	0	0	0	0	0
I/O-30	Jog Freq	X	X	X	X	X
DRV-05	S. Freq-1 (Spd 1)	0	0	0	1	0
DRV-06	S. Freq-2 (Spd 2)	0	0	1	0	0
DRV-07	S. Freq-3 (Spd-3)	0	0	1	1	0
I/O-31	S. Freq-4 (Spd-4)	0	1	0	0	0
I/O-32	S. Freq-5 (Spd-5)	0	1	0	1	0
I/O-33	S. Freq-6 (Spd-6)	0	1	1	0	0
I/O-34	S. Freq-7 (Spd-7)	0	1	1	1	0
I/O-35	S. Freq-8 (Spd-8)	1	0	0	0	0
I/O-36	S. Freq-9 (Spd-9)	1	0	0	1	0
I/O-37	S. Freq-10 (Spd-10)	1	0	1	0	0
I/O-38	S. Freq-11 (Spd-11)	1	0	1	1	0
I/O-39	S. Freq-12 (Spd-12)	1	1	0	0	0
I/O-40	S. Freq-13 (Spd-13)	1	1	0	1	0
I/O-41	S. Freq-14 (Spd-14)	1	1	1	0	0
I/O-42	S. Freq-15 (Spd-15)	1	1	1	1	0

0: OFF, 1: ON, X: Ignored (Jog first)

Speed-L: Lowest bit in Multi-Step speed input

Speed-M: Middle bit in Multi-Step speed input

Speed-H: High bit in Multi-Step speed input

Speed-X: Highest bit in Multi-Step speed input

Note 1: 'Speed 0' is set in DRV-04.

Note 2: If the 'Jog' terminal is ON, inverter operates at Jog frequency regardless of other terminal inputs.

DRV-04 Data	DRV-00 Speed 0	Freq source
Keypad-1	Digital Freq Ref	Keypad
Keypad-2	Digital Freq Ref	Keypad
V1	Analog Freq Ref.	Terminal
V1S	Analog Freq Ref.	Terminal
I	Analog Freq Ref.	Terminal
V1+I	Analog Freq Ref.	Terminal
Pulse	Pulse Freq Ref.	Terminal
Int. 485	Communication	Terminal
Ext. PID	Ext. PID Freq Ref.	Keypad or Terminal

♣ Setting example

M1=Speed-L, M2=Speed-M, M3=Speed-H, M4=Jog

M5=BX, M7=FX, M8=RX

Step speed is to be set in DRV-05~06, I/O-31~42

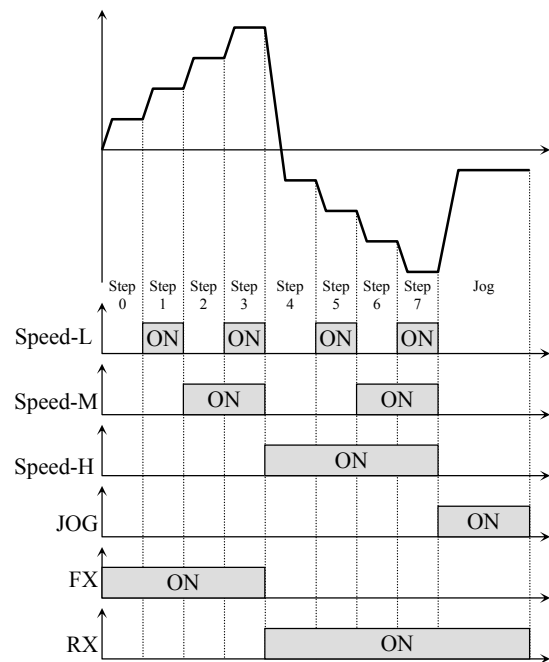

[Multi-Step Frequency Operation]

I/O-50~63: 1st~7th Accel/Decel Time

I/O ▶ Acc time-1
 50 20.0 sec **50** **20.0**

Factory Default: 20.0 sec **20.0**

I/O ▶ Dec time-1
 51 20.0 sec **51** **20.0**

Factory Default: 20.0 sec **20.0**

-
-
-

[XCEL-L, XCEL-M, XCEL-H]

By setting M1, M2 and M3 terminals to ‘XCEL-L’, ‘XCEL-M’ and ‘XCEL-H’ respectively, up to 8 different Accel and Decel times can be used. The Accel/Decel time is set in DRV-01 ~ DRV-02 and I/O-50 ~ I/O-63.

The Accel/Decel time is determined by the combination of M1, M2 and M3 terminals as shown in the following table.

Parameter Code	Accel/Decel Time	XCEL-H (M3)	XCEL-M (M2)	XCEL-L (M1)
DRV-01	Accel Time-0	0	0	0
DRV-02	Decel Time-0	0	0	0
I/O-50	Accel Time-1	0	0	1
I/O-51	Decel Time-1			
I/O-52	Accel Time-2	0	1	0
I/O-53	Decel Time-2			
I/O-54	Accel Time-3	0	1	1
I/O-55	Decel Time-3			
I/O-56	Accel Time-4	1	0	0
I/O-57	Decel Time-4			
I/O-58	Accel Time-5	1	0	1
I/O-59	Decel Time-5			
I/O-60	Accel Time-6	1	1	0
I/O-61	Decel Time-6			
I/O-62	Accel Time-7	1	1	1
I/O-63	Decel Time-7			

0: OFF, 1: ON

Output Frequency

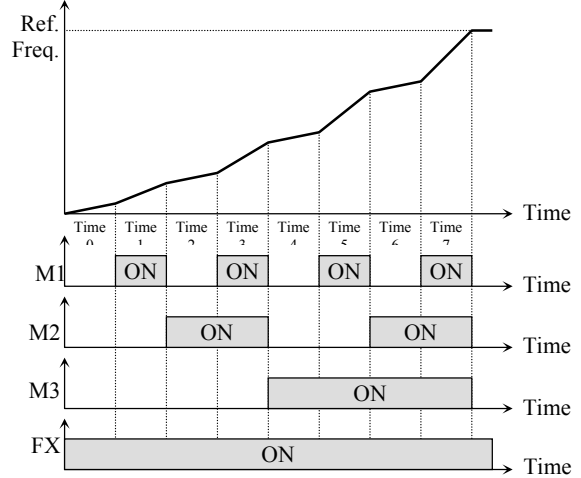

[Multi-Accel/Decel Time Operation]

[Dc-brake]

DC Injection Braking can be activated during inverter stop by configuring one of the Programmable digital input terminals (M1-M8) to ‘Dc-brake’. The preset DC-start value in FU1-22 is applied. To activate the DC Injection Braking, close the contact of the assigned terminal while the inverter is stopped.

[2nd function]

See APP 20~29 for details.

[Exchange]

Exchange is used to bypass the motor from the inverter line to commercial power or the opposite. To bypass the motor to commercial line, set the ‘Exchange’ function in one of the Programmable digital input terminal in I/O-20~27 and ‘INV line’, ‘COMM line’ function in Programmable digital output terminal (AX-CX) in I/O-76~79.

Speed search function (FU2-22) is activated automatically during exchanging operation, enabling smooth exchange.

The following 3 setting should be made to activate this function;

- 1) Set one of the Programmable digital input terminal (I/O-20~27) to 8 “Exchange.”
- 2) Set one of the Programmable digital (Aux. Contact) Output terminal to 16 “INV line.”
- 3) Set one of the Programmable digital (Aux. Contact) Output terminal to 17 “COMM line.”

Note: I/O-29 [Filtering Time Constant for Programmable Digital Input Terminals] must be set to more than 100 [msec] to prevent chattering and momentary malfunction during this function.

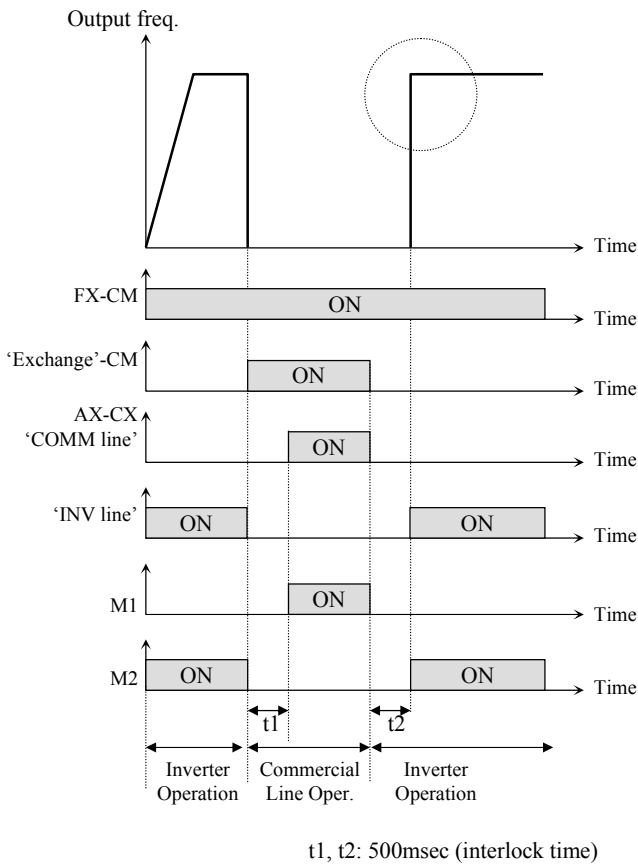

[Exchanging Sequence]

[Up, Down]

By using the Up and Down function, the drive can accelerate to a steady speed and decelerate down to a desired speed by using only two input terminals. Setting limit is Maximum frequency.

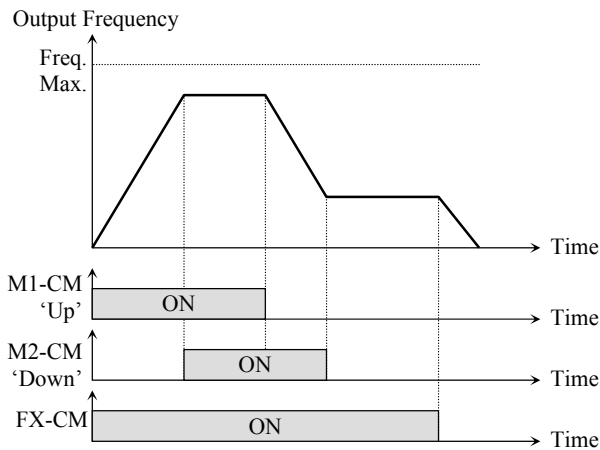

[Up/Down Operation]

[3-Wire]

This function is for 3-wire start/stop control. This function is mainly used with a momentary push button to hold the current frequency output during acceleration or deceleration.

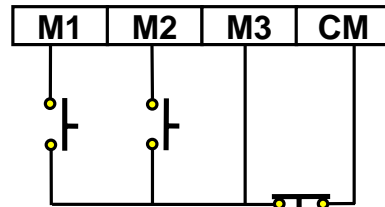

[Wiring for 3-Wire Operation, M3 set to '3-Wire']

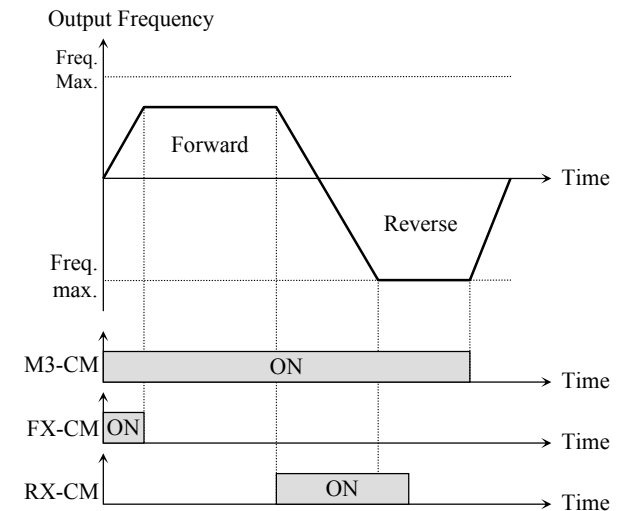

[3-Wire Operation]

[Ext Trip]

This is a normally open contact input. When a terminal set to 'Ext Trip' is ON, inverter cuts off its output and displays the fault. This can be used as an external latch trip. The logic is programmable in I/O-94 [Normal Open/Normal Close select].

[iTerm Clear]

This function is used for PID control. When this terminal is ON, the accumulated value by I-Gain is set to '0'. Refer to PID Control Block Diagram.

[Open-loop]

This is used to exchange the control mode of inverter from PID mode (Close Loop) to V/F mode (Open Loop).

DRV-03 [Drive Mode] and DRV-04 [Frequency Mode] are applied when the mode has been changed.

Note: Only used when the inverter is stopped.

[Main-drive]

When an option board or embeded RS485 communication is used for the frequency setting and the run/stop command setting, and the setting is ON, the inverter operation can be changed to Option (or RS485) operation without changing parameters. The set values in DRV-92 [Frequency Mode 2] and DRV-91 [Drive Mode 2] are applied to the Option (or RS485) operation.

Note: To switch to RS485 communication operation during Main-drive operation, Stop the inverter first and disable Main-drive and connect RS485 communication.

[Analog hold]

When there is an analog input signal for frequency reference and ‘Analog hold’ terminal is ON, inverter fixes its output frequency regardless of the frequency reference. When the terminal is OFF, the actual frequency reference will be applied. This function is useful when a system requires constant speed after acceleration or freq reference is not necessary to be changed.

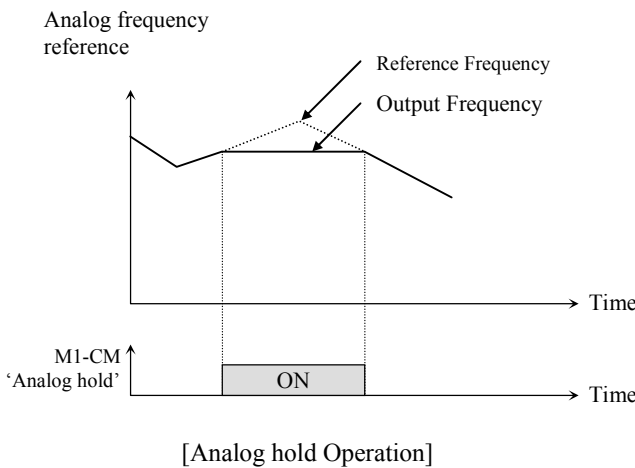

[XCEL stop]

Inverter stops accelerating and decelerating when this terminal is ON.

[P Gain 2]

This function is used to change P-Gain during PID operation. When this terminal is ON, PID controller changes P-Gain to PID P2-Gain. Refer to PID Control Block Diagram.

[Interlock 1, 2, 3, 4]

This function is used for MMC operation. When MMC is selected in APP-01 and interlock is set, M1, M2, M3 and M4 are automatically assigned for Interlock function. Therefore, these terminals cannot be used for setting other functions when interlock is active. Use M5, M6, M7, and M8 for other function setting. Refer to MMC operation.

[Reset]

This function is set to use it as fault reset terminal when ON.

[BX]

This function is set to use it as Emergency Stop terminal when ON.

[JOG]

This function is set to use Jog operation terminal when ON.

[FX/RX]

This function is set to issue Forward/Reverse Run.

[Ana Change]

Inverter changes its frequency reference source from V1 to I when ON.

Ex) In the case of V1+I operation, V1 is the default setting and it is changed to I operation when the terminal is turned ON.

[Pre excite]

This setting switches the inverter to pre-excitation state. This function applies the DC magnetizing current to a motor to build the flux in Sensorless control. When the operation command is set to ON, the state changes from pre-excitation to normal.

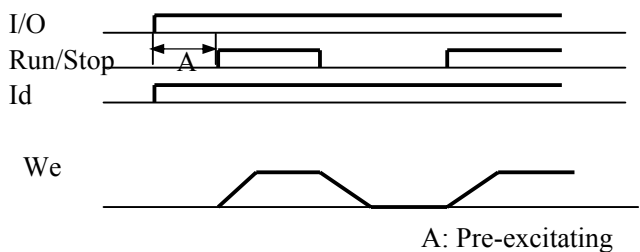

[Ext.PID Run]

External PID controller begins operation when the defined terminal is turned ON. This can be operated regardless of inverter reference command or used in conjunction with internal PID operation. Refer to External PID operation for details.

I/O-70~73: S0, S1 terminal select

I/O▶ S0 mode 70 Frequency	70	0
------------------------------	-----------	----------

Factory Default: Frequency **0**

I/O▶ S0 adjust 71 100 %	71	100
----------------------------	-----------	------------

Factory Default: 100 % **100**

I/O▶ S1 mode 72 Frequency	72	0
------------------------------	-----------	----------

Factory Default: Frequency **0**

I/O▶ S1 adjust 73 100 %	73	100
----------------------------	-----------	------------

Factory Default: 100 % **100**

Analog meter displays the inverter output Frequency, Current, Voltage, DC link voltage and External PID output with pulse signals on the S0, S1 terminal. The average output voltage range is 0V to 10V. I/O-71, 73 are used to adjust the S0, S1 output gain value.

[Frequency]

S0/S1 terminal outputs inverter output frequency. The output value is determined by,
 $S0/S1 \text{ Output Voltage} = (\text{Output freq.} / \text{Max. freq.}) \times 10V \times (\text{IO-71 or 73}) / 100$

[Current]

S0/S1 terminal outputs inverter output current. The output value is determined by,
 $S0/S1 \text{ Output Voltage} = (\text{Output current} / \text{Rated current}) \times 10V \times (\text{IO-71 or 73}) / 100$

[Voltage]

S0/S1 terminal outputs inverter output voltage. The output value is determined by,
 $S0/S1 \text{ Output Voltage} = (\text{Output voltage} / \text{Max. output voltage}) \times 10V \times (\text{IO-71 or 73}) / 100$

[DC link vtg]

S0/S1 terminal outputs the DC link voltage of inverter. The output value is determined by,
 $S0/S1 \text{ Output Voltage} = (\text{DC link voltage} / \text{Max. DC link voltage}) \times 10V \times (\text{IO-71 or 73}) / 100$

[Ext.PID Out]

S0/S1 terminal outputs External PID output. The output value is determined by,
 $S0/S1 \text{ output voltage} = (\text{External PID output} / 10000) * 10V * S0,S1 \text{ output gain}(\text{I/O-71,73}) / 100$

Note: Maximum DC Link Voltage for 200V class is 410V and for 400V class 820V.

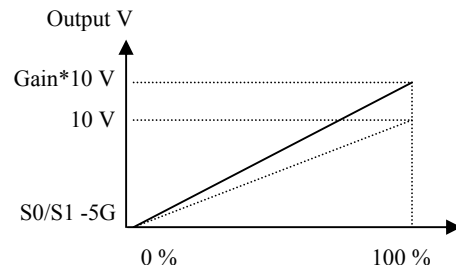

**I/O-74: FDT (Frequency Detection) Level
I/O-75: FDT Bandwidth**

I/O▶ FDT freq 74 30.00 Hz	74	30.00
------------------------------	-----------	--------------

Factory Default: 30.00 Hz **30.00**

I/O▶ FDT band 75 10.00 Hz	75	10.00
------------------------------	-----------	--------------

Factory Default: 10.00 Hz **10.00**

These functions are used in I/O-76-79 [Programmable Digital Auxiliary Output Terminal]. See [FDT-#] in I/O-76~79.

Use Sub-Boards if you need to use Programmable Digital output terminal Q1, Q2, and Q3.

I/O-76~79: Programmable Digital Auxiliary Contact
Output mode 1, 2, 3, 4 define (AX-CX)

I/O▶ Aux model	76	0
76 None		

Factory Default: None **0**

The auxiliary contact works (Close) when the defined condition has occurred.

Setting Range	Description
None	None
FDT-1	Output frequency arrival detection
FDT-2	Specific frequency level detection
FDT-3	Frequency detection with pulse
FDT-4	Frequency detection 1 with contact closure
FDT-5	Frequency detection 2 with contact closure
OL	Overload detection
IOL	Inverter overload detection
Stall	Stalling
OV	Over voltage detection
LV	Low voltage detection
OH	Inverter overheat detection
Lost Command	Lost command detection
Run	Inverter running detection
Stop	Inverter stop detection
Steady	Steady speed detection
INV line	Exchange signal outputs
COMM line	
Ssearch	Speed search mode detection
Ready	Inverter ready detection
MMC	Used for MMC operation

[FDT-1]

When the output frequency reaches the reference frequency (target frequency), AX-CX terminal is CLOSED.

Detecting Condition: Value (Ref. Freq-Output Freq) <= Freq Detection Bandwidth (I/O-75)/2

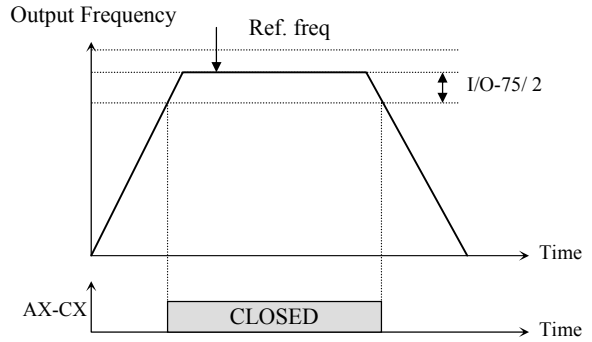

[AX-CX configured as 'FDT-1']

*AX: A1~A4, CX: C1~C4

[FDT-2]

AX-CX is CLOSED when the reference frequency is in I/O-75 [FDT Bandwidth] centered on I/O-74 [FDT Frequency], and the output frequency reaches I/O-75 centered on I/O-74.

Detecting Condition: FDT-1 condition & (Value (Output Freq- Freq Detection) <= Freq Detection Bandwidth (I/O-75)/2)

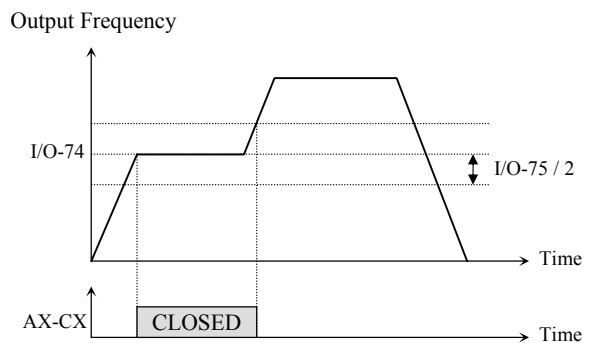

[AX-CX configured as 'FDT-2']

[FDT-3]

AX-CX is CLOSED when the output frequency reaches the band centered on the FDT frequency. The output is OPENED when the output frequency goes outside the FDT bandwidth centered on the FDT frequency.

Detecting Condition: Value (Freq Detection (I/O-74)-Output Freq) <= Freq Detection Bandwidth (I/O-75)/2

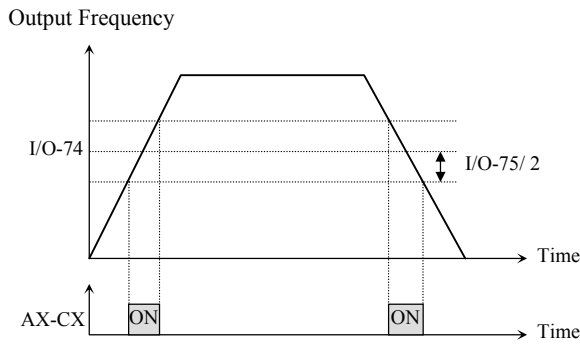

[AX-CX configured as 'FDT-3']

[FDT-4]

AX-CX is CLOSED when the output frequency reaches the FDT frequency. The output is OPENED when the output frequency goes below the FDT bandwidth centered on the FDT frequency.

Detecting Condition:

During Accel: Output freq \geq Freq Detection

During Decel: Output freq $>$ (Freq Detection (I/O-74) - Freq Detection Bandwidth (I/O-75)/2)

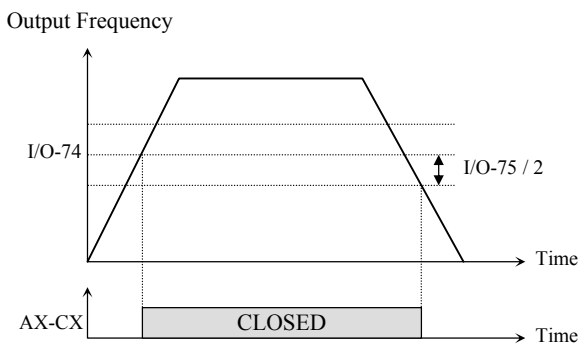

[AX-CX configured as 'FDT-4']

[FDT-5]

This is the inverted output of [FDT-4].

Detecting Condition:

During Accel: Output freq \geq Freq Detection

During Decel: Output freq $>$ (Freq Detection (I/O-74) - Freq Detection Bandwidth (I/O-75)/2)

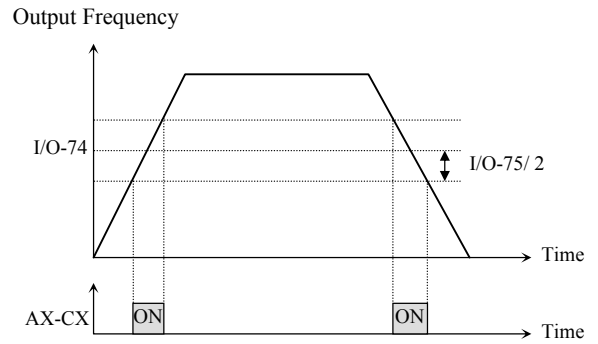

[AX-CX configured as 'FDT-5']

[OL]

AX-CX is CLOSED when the output current has reached the FU1-64 [Overload Warning Level] for the FU1-65 [Overload Warning Time].

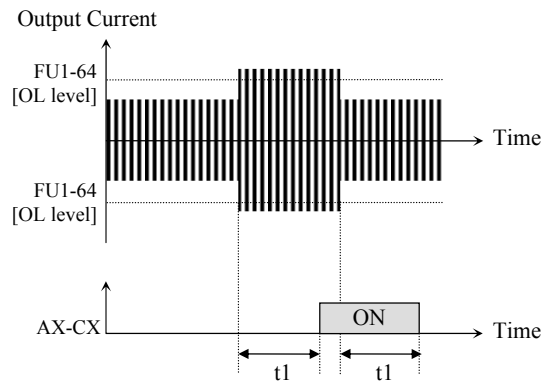

t1: FU1-65 [Overload Warning Time]

[AX-CX configured as 'OL']

[IOL]

AX-CX is CLOSED when the output current is above the 110% of rated inverter current for 60 seconds. If this situation is continued for one minute, the inverter will cut off its output and displays 'IOL' (Inverter overload) Trip. See the nameplate for the rated inverter current.

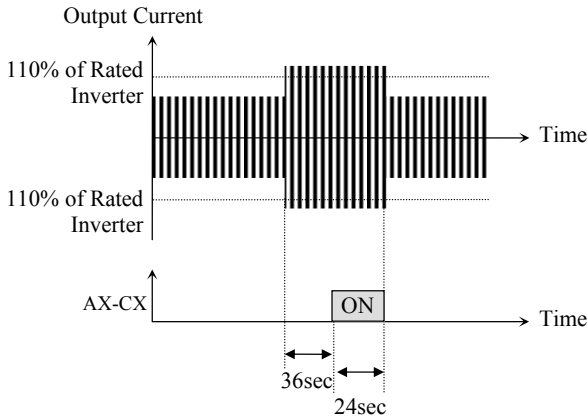

[AX-CX configured as 'IOL']

[Stall]

AX-CX is CLOSED when the inverter is on the stall prevention mode.

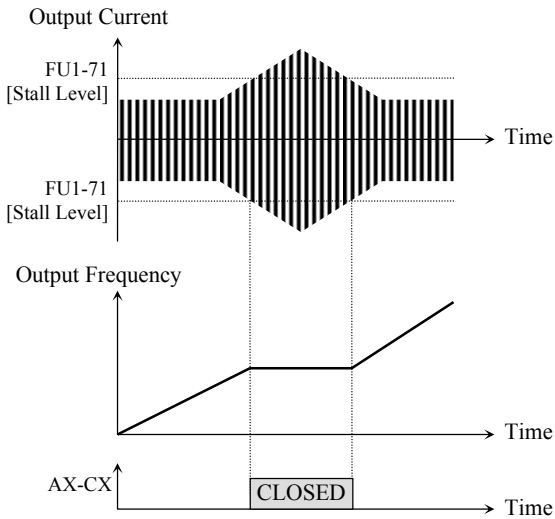

[AX-CX configured as 'Stall']

[OV]

AX-CX is CLOSED when the DC link voltage is above the Over-voltage level.

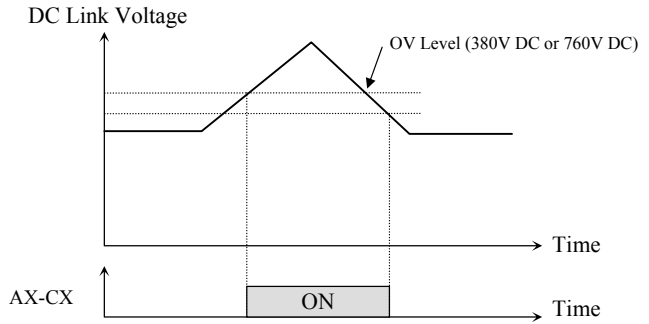

[AX-CX configured as 'OV']

[LV]

AX-CX is CLOSED when the DC link voltage is below the Low-voltage level.

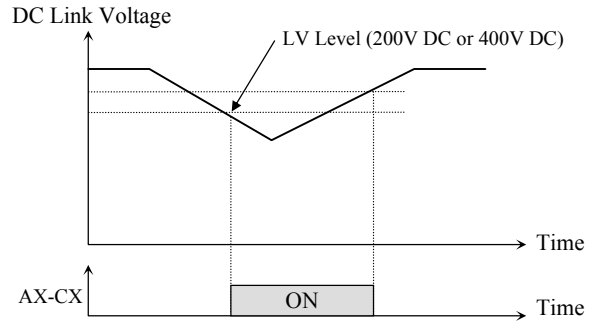

[AX-CX configured as 'LV']

[OH]

AX-CX is CLOSED when the heat sink of the inverter is above the reference level.

[Lost Command]

AX-CX is CLOSED when frequency reference is lost.

[Run]

AX-CX is CLOSED when the inverter is running.

[Stop]

AX-CX is CLOSED when the inverter is stopped.

[Steady]

AX-CX is CLOSED when the inverter is running at constant speed.

[INV line, COMM line]

This function is used in conjunction with ‘Exchange’ function of Programmable digital input for commercial line exchange.

The following three conditions should be set:

- 1) Define one of the Programmable digital input terminals to “Exchange”.
- 2) Define one of the Programmable digital output terminals to “INV line”.
- 3) Define one of the Programmable digital output terminals to “COMM line”.

Note: Set I/O-29 above 100 msec at Exchange operation. This helps to prevent chattering and momentary malfunction.

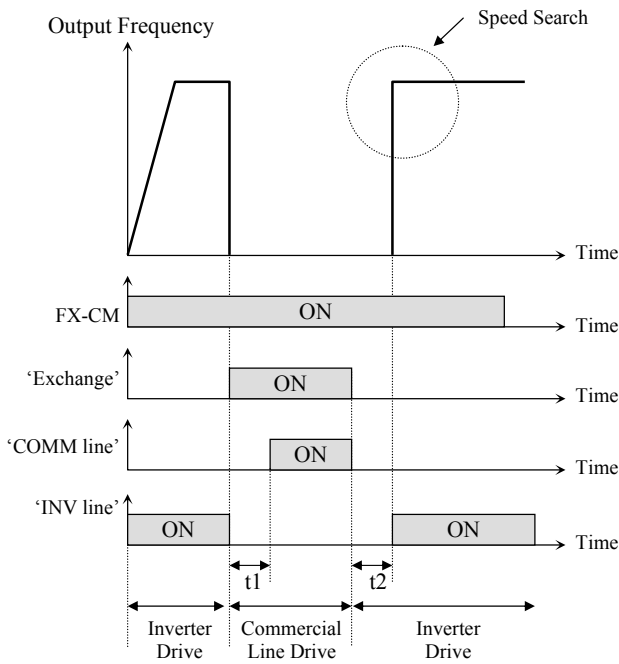

t1, t2: 500msec (interlock time)

[AX-CX configured as ‘COMM line’,
‘Exchange’ and INV line’]

[Ssearch]

AX-CX is CLOSED during the inverter is speed searching.

[Ready]

AX-CX is CLOSED when the inverter is ready to run.

[MMC]

Automatically set to ‘MMC’ when ‘MMC’ is selected in APP-01.

I/O-80: Fault Output Relay (3A, 3B, 3C)

I/O▶ Relay mode	80	010
80 010		

Factory Default:	010	010
------------------	-----	------------

This function is used to allow the fault output relay to operate when a fault occurs. The output relay terminal is 3A, 3B, 3C where 3A-3C is a normally open contact and 3B-3C is a normally closed contact.

Bit	Setting	Display	Description
Bit 1 (LV)	0	000	Fault output relay does not operate at ‘Low voltage’ trip.
	1	001	Fault output relay operates at ‘Low voltage’ trip.
Bit 2 (Trip)	0	000	Fault output relay does not operate at any fault.
	1	010	Fault output relay operates at any fault except ‘Low voltage’ and ‘BX’ (inverter disable) fault.
Bit 3 (Retry)	0	000	Fault output relay does not operate regardless of the retry number.
	1	100	Fault output relay operates when the retry number set in FU2-26 decreases to 0 by faults. Disabled while Auto retry is ON.

When several faults occurred at the same time, Bit 1 has the first priority. (Active order: Bit 1->Bit 2->bit3)

I/O-81: Terminal Output Status

I/O▶ Out status
81 00000000 **81** **0000**

Factory Default: 00000000 **0000**

This code displays the output status of control terminals.

[LCD Keypad Display]

Output Terminals	3A-3C	Q3	Q2	Q1	AUX 4	AUX 3	AUX 2	AUX 1
	Bit 7	Bit 6	Bit 5	Bit 4	Bit 3	Bit 2	Bit 1	Bit 0
OFF status	0	0	0	0	0	0	0	0
ON status	1	1	1	1	1	1	1	1

I/O-82, 83: Fault Relay On/Off Delay Time

I/O▶ Relay On
82 0.0 sec **82** **0.0**

Factory Default: 0.0 sec **0.0**

I/O▶ Relay Off
83 0.0 sec **83** **0.0**

Factory Default: 0.0 sec **0.0**

Fault relay output is delayed for the set time and it is turned ON/OFF after the set time.

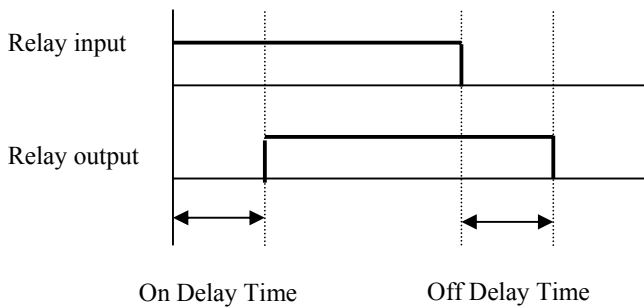

I/O-84: Cooling Fan Control Selection

I/O▶ Fan Con. Sel
84 PowerOn_Fan **84** **0**

Factory Default: PowerOn_Fan **0**

I/O-84		Description
0	PowerOn Fan	Fan ON when inverter power is ON.
1	Run Fan	Fan ON when inverter runs (outputs its frequency).
2	Temper Fan	Fan ON when inverter temp exceeds the preset value in I/O-85.

Caution: I/O-84, 85 are only available for inverters 37kW and higher.

I/O-86, -87, -88: User Unit selection for V1, I, Pulse input (to change Analog input value display)

I/O▶ V1 Unit Sel
86 Speed **86** **0**

Factory Default: Speed **0**

I/O▶ I Unit Sel
87 Speed **87** **0**

Factory Default: Speed **0**

I/O▶ PulseUnitSel
88 Speed **88** **0**

Factory Default: Speed **0**

No	I/O-86,-87,-88 set data	Description
0	Speed	Displayed in [Hz]. It is changed to [Rpm] when DRV-16 is set to [Rpm].
1	Percent	Flow rate, pressure and temperature are displayed in [%].
2	Bar	Pressure is displayed in [Bar].
3	mBar	Pressure is displayed in [mBar].
4	kPa	Pressure is displayed in [kPa].
5	Pa	Pressure is displayed in [Pa].

Set "Yes" in more than one code among APP-02

[PID operation selection], APP-80 [Ext. PID operation selection] and APP-62 [PID Bypass selection]. Then, set one of the desired unit among Percent, Bar, mBar, kPa, and Pa in I/O-86, 86, 88. In this case, all unit display related to inverter target frequency are changed.

When APP-02 [PID operation selection], APP-80 [Ext. PID operation selection] and APP-62 [PID Bypass selection] setting value is “0”, I/O-86, -87, -88 are initialized to Speed [Hz]. If DRV-16 is changed to [Rpm], unit display is changed from [Hz] to [Rpm].

**I/O-90, 91: Inverter Number, Baud Rate
I/O-92, 93: Operation method when communication signal is lost, Communication Time Out
I/O-94: Communication Delay Time**

I/O▶ Inv No. 90 1	90	1
Factory Default: 1		1
I/O▶ Baud rate 91 9600 bps	91	3
Factory Default: 9600 bps		3
I/O▶ COM Lost Cmd 92 None	92	0
Factory Default: None		0
I/O▶ COM Time Out 93 1.0 sec	93	1.0
Factory Default: 1.0 sec		1.0
I/O▶ Delay Time 94 5	94	5
Factory Default: 5 ms		5

I/O-90 [Inverter Number] sets the inverter ID to perform RS485 communication with PC. I/O-91 [Baud rate] sets the communication speed. To make the multi-drop system, connect the terminal C+ to other inverter’s C+ and C- to C-.

I/O-92, 93 are only displayed when DRV-03 [Drive mode] or DRV-04 [Frequency mode] is set to 4 “Int.

485”.

In this case, the LCD display shows “LOR”.

I/O-93 [Communication time out] determines whether the signal is lost.

Three types of operating method described on the table below are settable after loss of communication signal.

Setting Range	Description
None	Continuous operation after loss of communication signal.
FreeRun	Inverter cuts off its output after determining loss of communication signal.
Stop	Inverter stops by its Decel pattern and Decel time after determining communication signal.

I/O-94 setting is for communication using 232-485 converter. It should be set properly according to 232-485 converter specification.

I/O-95: Normal Open/ Normal Close select

I/O▶ In No/NC Set 95 00000000000	95	0000
Factory Default: 00000000000		0000

The input contact logic (Normal Open-A Contact/Normal Close-B Contact) for M1, M2, M3, M4, M5, M6, M7, M8, P4, P5 and P6 can be programmed in this code. P4, P5 and P6 are settable only with Sub-board installed.

[LCD KEYPAD DISPLAY]

Input T/M	P6	P5	P4	M8	M7	M6	M5	M4	M3	M2	M1
	10 bit	9 bit	8 bit	7 bit	6 bit	5 bit	4 bit	3 bit	2 bit	1 bit	0 bit
0: NO	0/1	0/1	0/1	0/1	0/1	0/1	0/1	0/1	0/1	0/1	0/1
1: NC	0/1	0/1	0/1	0/1	0/1	0/1	0/1	0/1	0/1	0/1	0/1

Chapter 6 - Parameter Description [I/O]

I/O-96: Input Checking Time

I/O In CheckTime
96 1 ms

96

1

Factory Default: 1 ms

1

When Multi-step speed or Multi-Accel/Decel operation is active, inverter determines the input to be valid after the I/O-95 [Input checking time] elapses.

Output
freq [Hz]

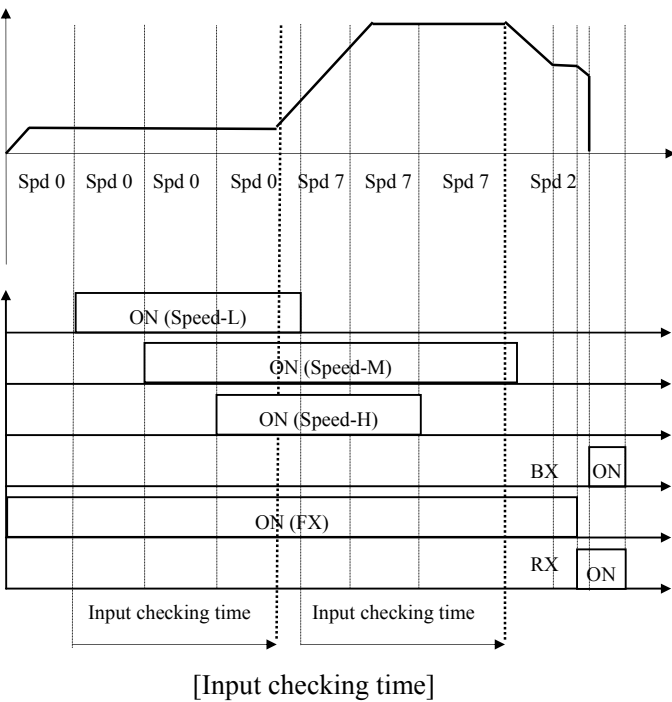

[Input checking time]

I/O-97: Overheat Trip Selection

I/O OH Trip Sel
97 111

97

111

Factory Default: 111

111

I/O MO Trip Temp
98 110

98

110

Factory Default: 110 [°C]

110

Inverter Overheat protection is activated regardless of motor temp setting condition.

Code	Bit set			Function	On	Off
	3	2	1			
I/O-97			●	Motor overheat trip setting (tripped at I/O-98)	1	0
		●		-Reserved-	1	0
	●			External temperature sensor selection (PTC/NTC)	1	0

Caution: Bit 2 is reserved for future use.

Specification of External PTC/NTC Thermistor

Sensor	Resistance based on 25	Resistance by temperature	Measurable Temp range
PTC	1 (5%)	$R(T)=[1+A*(Measured\ temp-25)+B*(Measured\ temp - 25)^2][\]$ $A=7.635 \times 10^{-3}, B=1.371 \times 10^{-5}$	0~125[]
NTC	2.545 (5%)	See the table below for NTC resistance by temperature.	0~150[]

Note : Measurable temp range varies by thermal sensors. Select the sensor after checking the measurable temp range specification.

NTC resistance according to temperature

Temp []	Resistance []	Temp []	Resistance []	Temp []	Resistance []	Temp []	Resistance []	Temp []	Resistance []	Temp []	Resistance []	Temp []	Resistance []
80	0.3562	90	0.2649	100	0.2002	110	0.1536	120	0.1195	130	0.0942	140	0.0752
81	0.3455	91	0.2574	101	0.1949	111	0.1497	121	0.1167	131	0.0921	141	0.0736
82	0.3353	92	0.2502	102	0.1897	112	0.1459	122	0.1139	132	0.0900	142	0.0720
83	0.3254	93	0.2432	103	0.1847	113	0.1423	123	0.1112	133	0.0880	143	0.0705
84	0.3158	94	0.2364	104	0.1798	114	0.1387	124	0.1085	134	0.0860	144	0.0690
85	0.3066	95	0.2299	105	0.1751	115	0.1353	125	0.1060	135	0.0841	145	0.0675
86	0.2976	96	0.2236	106	0.1705	116	0.1319	126	0.1035	136	0.0822	146	0.0661
87	0.2890	97	0.2174	107	0.1661	117	0.1287	127	0.1011	137	0.0804	147	0.0647
88	0.2807	98	0.2115	108	0.1618	118	0.1255	128	0.0987	138	0.0786	148	0.0633
89	0.2727	99	0.2058	109	0.1577	119	0.1225	129	0.0965	139	0.0769	149	0.0620
												150	0.0608

Note: Use the external NTC having the specification above and adjust I/O-98 when the temp difference between inverter and external sensor is occurred.

Note: Overheat protection can be monitored by setting one of the I/O-76~79 [Aux mode 1, 2, 3] to “OH”.

6.5 Application group [APP]

APP-00: Jump to desired code

APP▶ Jump code
00 1

Factory Default: 1

Jumping directly to any parameter code can be accomplished by entering the desired code number. This code is available only with LCD keypad.

APP-01: Application Mode Selection

APP▶ App. mode
01 None **01** **0**

Factory Default: None **0**

This code sets the application mode.

Setting Range	Description
None	Application mode is not selected.
MMC	MMC (Multi-Motor Control) mode is selected in application group. Related parameters (APP-40~71) are displayed. I/O-76~79 [Programmable digital Aux. relay output] is automatically set to "MMC." If less than 4 aux motors are connected, the remainder relays can be used for other functions.

Caution: I/O-76~79 value is not initialized automatically even though "None" is set after setting "MMC". In this case, set the I/O-76~79 again for desired selection.

APP-02: PID Operation Selection

APP▶ Proc PI mode
02 No **02** **0**

Factory Default: No **0**

This function can be used for Process control like flow, pressure, and air volume control.

To use this function, set APP-02 [proc PI mode] to "Yes". PID control detects the amount of feedback from a sensor and compares it with the target value. If the values differ, this function produces an output

to eliminate the deviation. In other words, this control matches the feedback amount with the target value.

For HVAC or Pump applications, the PID control can be used to adjust the actual output by comparing a feedback with a 'Set-point' given to the inverter. This 'Set-point' can be in the form of Speed, Temperature, Pressure, Flow level, etc. The 'Set-point' and the feedback signals are provided externally to the inverter analog input terminals. The inverter compares the signals in calculating 'total-error' which is reflected in the inverter output.

Note: PID control can be bypassed to manual operation temporarily by defining one of the multifunction input terminals (M1~M8, P4~P6) to "Open-loop". The inverter will change to manual operation from PID control when this terminal is ON, and change back to PID control when this terminal is OFF.

[P Control] This is to compensate the error for a system input proportionally. This is used to make the controller to respond fast for an error. When P control is used alone, the system is easily affected by an external disturbance during steady state.

[I Control] This is to compensate the error of a system integrally. This is used to compensate the steady state error by accumulating them. Using this control alone makes the system unstable.

[PI control] This control is stable in many systems. If "D control" is added, it becomes the 3rd order system. In some systems this may lead to system instability.

[D Control] Since the D control uses the variation ratio of error, it has the merit of controlling the error before the error is too large. The D control requires a large control quantity at start, but has the tendency of increasing the stability of the system. This control does not affect the steady state error directly, but increases the system gain because it has an attenuation effect on the system. As a result, the differential control component has an effect on decreasing the steady state error. Since the D control operates on the error signal, it cannot be used alone. Always use it with the P control or PI control.

Parameter setting example for PID operation

Set APP-02 [PID operation selection] to “Yes.”

Set APP-06 [PID feedback selection] among I, V1 and Pulse.

Set the unit to view feedback value in I/O-86~88 [User unit selection]. Then, all the unit related to inverter target frequency is changed.

Set the appropriate value in APP-04~05 (Refer to the following PID block diagram).

When APP-04 is set to “No,” DRV-04 [Freq Mode] becomes PID reference. If APP-04 is set to “Yes”, the value set in APP-05 becomes PID reference. If setting one of I/O-20~27 [Programmable digital input terminal selection] to “Open loop” and tuning On/Off the selected terminal, it is decided whether DRV-04 [Freq Mode] becomes Target freq or Target freq becomes PID Output.

PID Block Diagram

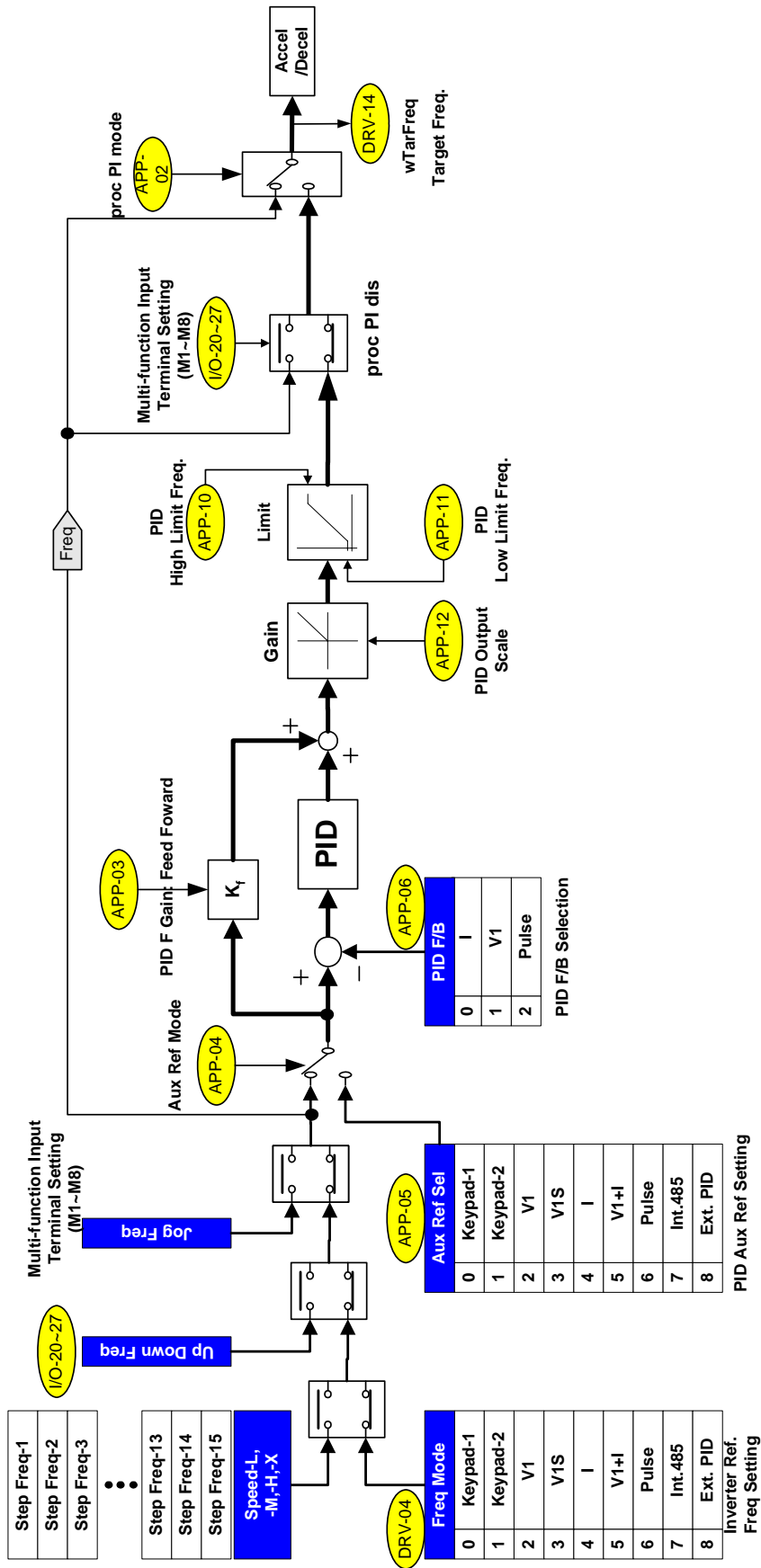

In general, the PID output becomes inverter's "Target Freq". In this case, PID is controlling the whole system and the PID output becomes the target freq of the system and inverter is operating according to Accel/Decel Time. PID control sampling time is 10msec.

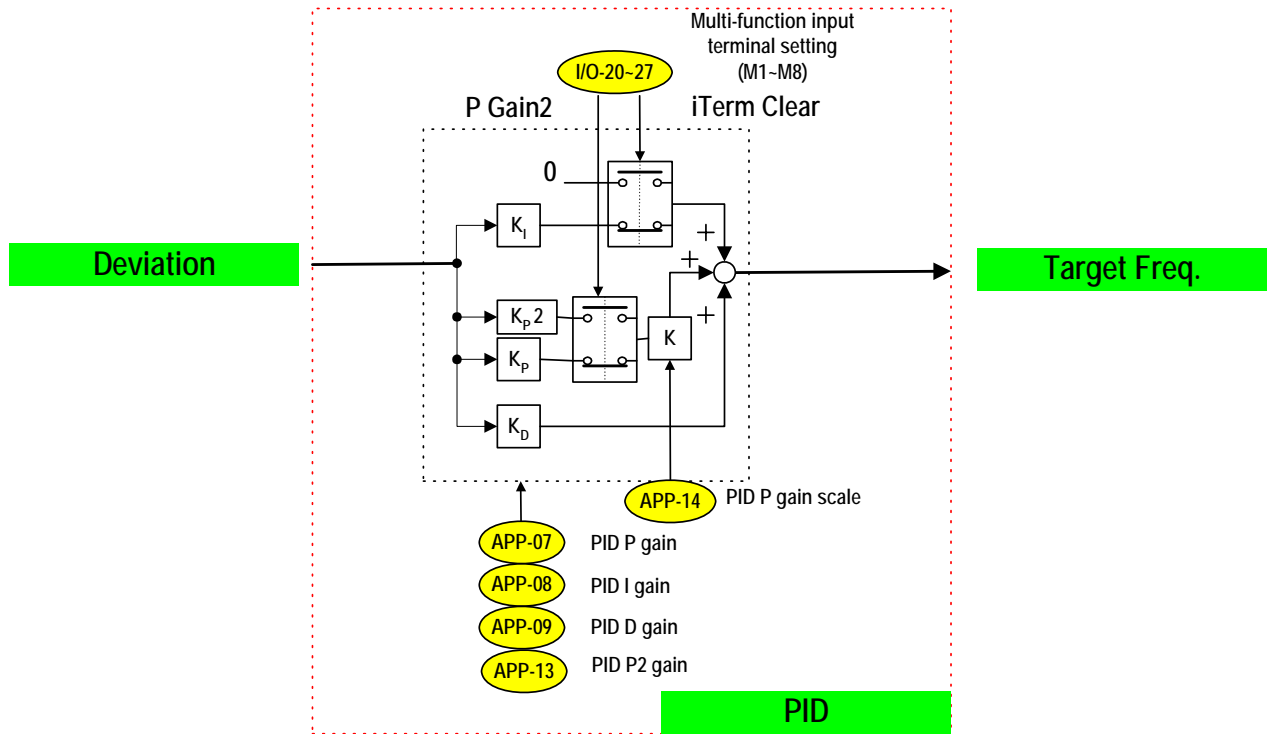

PID Wiring Example

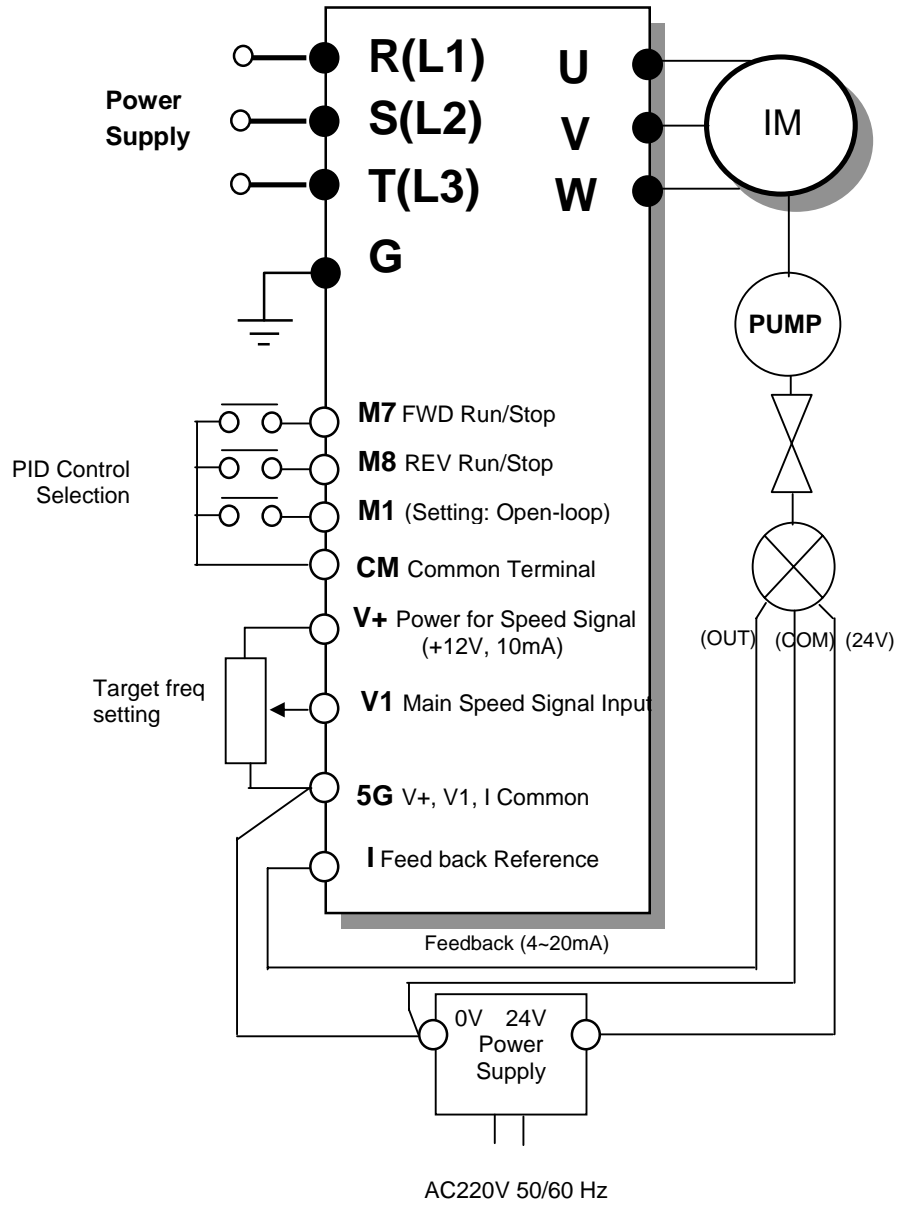

APP-03: PID F Gain
 APP-04: PID Aux. Reference Mode Selection
 APP-05: PID Aux. Reference Selection

APP▶ PID F-Gain 03 0.0 %	03	0.0
----------------------------------	-----------	------------

Factory Default: 0.0% **0.0**

This code sets F Gain for use in Feed Forward control.
 When it is set to 100%, the responsiveness (%) of output F gain from the controller reference value is 100%. Used when fast response is needed.

Caution: Control System output may become unstable if this value is set too high.

APP▶Aux Ref Mode 04 No	04	0
--------------------------------	-----------	----------

Factory Default: No **0**

This code selects PID Aux Ref. Input Enable/Disable. See PID Block Diagram for details.

APP▶ Aux Ref Sel 05 V1	05	2
--------------------------------	-----------	----------

Factory Default: V1 **2**

This code sets the source of Aux reference signal.

Caution: When APP-04 is set to “No,” DRV-04, Multi-step frequency, UP/DOWN, Jog frequency become PID controller’s reference and when set to “Yes,” PID reference is issued from the set value in APP-05 [PID Aux Reference signal selection] .

APP-06: PID Feedback Signal Selection
 APP-07: P Gain for PID Control
 APP-08: I Time for PID Control
 APP-09: D Time for PID Control
 APP-10: High Limit Frequency for PID Control
 APP-11: Low Limit Frequency for PID Control

APP▶ PID F/B 06 I	06	0
---------------------------	-----------	----------

Factory Default: I **0**

Select the feedback signal for PID control. This can be set one of ‘I’ (4-20mA), ‘V1’, ‘V2’ and ‘Pulse’ according to the signal (current or voltage) and the terminal (V1 (0-10V), V2 (Sub-B board)) or Pulse (0~100kHz). Refer to I/O 6-10 for I, I/O1-5 for V1, I/O-11~16 for Pulse and EXT-6-10 [V2 Analog Ref. Freq setting] for V2.

APP▶ PID P-gain 07 1.0 %	07	1.0
----------------------------------	-----------	------------

Factory Default: 1.0 % **1.0**

Set the proportional gain for PID control. When P-Gain is set at 100% and I-Time at 0.0 second, it means the PID controller output is 100% for 100% error value. P-Gain is set to 50% and I- Time to 0.0 sec, PID controller output becomes 50% for 100% error value.

APP▶ PID I-time 08 10.0 sec	08	10.0
-------------------------------------	-----------	-------------

Factory Default: 10.0 sec **10.0**

Set the integral gain for PID control. This is the time the PID controller takes to output 100% for 100% error value. For example, when it is set to 30 sec, 30 sec is taken for PID controller to output 100% for 100% error value. 100% error means feedback value is 0 to the preset reference value.

APP▶ PID D-time 09 0.0 ms	09	0.0
-----------------------------------	-----------	------------

Factory Default: 0.0 ms **0.0**

Set the differential gain for PID control.

APP▶ PID limit-H 10 60.00 Hz	10	60.00
--------------------------------------	-----------	--------------

Factory Default: 60.00 Hz	60.00
---------------------------	--------------

This is the frequency upper limit at which the output frequency is limited during PID control.

APP▶ PID limit-L 11 0.5 Hz	11	0.5
-------------------------------	-----------	------------

Factory Default: 0.5 Hz	0.5
-------------------------	------------

This is the frequency lower limit at which the output frequency is limited during PID control.

APP-12: PID Output Scale APP-13: PID P2 Gain APP-14: P Gain Scale
--

APP▶PID Out Scale 12 100.0 %	12	100.0
---------------------------------	-----------	--------------

Factory Default: 100.0 %	100.0
--------------------------	--------------

This code sets the scale of PID controller output.

APP▶ PID P2-gain 13 100.0 %	13	100.0
--------------------------------	-----------	--------------

Factory Default: 100.0 %	100.0
--------------------------	--------------

This code sets the second P-Gain for PID control.

APP▶P-gain Scale 14 100.0 %	14	100.0
--------------------------------	-----------	--------------

Factory Default: 100.0 %	100.0
--------------------------	--------------

This code sets the conversion scale of P-Gain and P2-Gain.

APP▶ PID Out Inv. 15 No	15	0
----------------------------	-----------	----------

Factory Default: No	0
---------------------	----------

APP-15 [Output inversion] sets PID controller's output inversion.

APP▶ PID U Fbk 17 No	17	0
-------------------------	-----------	----------

Factory Default: NO	0
---------------------	----------

This code is useful for fan and pumps application. It converts linear pattern of a feedback sensor to the squared pattern without any setting.

PID output value can be set to '0' by setting a Programmable digital input terminals (M1 ~ M8) to 'Open loop' in I/O- I/O-20 ~ I/O-27.

The accumulated value by I-Gain can be set to '0' by setting a Programmable digital input terminal (M1 ~ M8) to 'iTerm Clear' in I/O-20 ~ I/O-27.

The P-Gain 2 can be selected for PID controller by setting a Programmable digital input (I/O-20 ~ I/O-27) to 'Open-loop'.

When APP-02 [PID operation selection] is set to "Yes," a desired display unit in I/O-86, -87, -88 [User Unit selection] is set among Speed, Percent, Bar, mBar, kPa, Pa, which affects value display of APP-06[PID feedback selection], all the parameter unit related to inverter target frequency is changed.

APP-20 ~ APP-29: 2nd Functions
--

APP▶2 nd Acc time 20 5.0 sec	20	5.0
--	-----------	------------

Factory Default: 5.0 sec	5.0
--------------------------	------------

APP▶2 nd Dec time 21 10.0 sec	21	10.0
---	-----------	-------------

Factory Default: 10.0 sec	10.0
---------------------------	-------------

These functions are displayed only when one of the multifunction inputs in codes I/O-20 to I/O-27 is set at '2nd func'.

When an inverter is controlling two motors by exchanging, different values can be set for the 2nd motor by using the multifunction input terminal. Following a cross reference table shows the 2nd functions corresponding to the 1st functions.

Description	1 st Functions	2 nd Functions
Acceleration time	DRV-01 [Acc. time]	APP-20 [2nd Acc time]
Deceleration time	DRV-02 [Dec. time]	APP-21 [2nd Dec time]
Base Frequency	FU1-31 [Base freq]	APP-22 [2nd BaseFreq]
Volts/Hz mode	FU1-40 [V/F Pattern]	APP-23 [2nd V/F]
Forward torque boost	FU2-68 [Fwd Boost]	APP-24 [2nd F-boost]
Reverse torque boost	FU2-69 [Rev Boost]	APP-25 [2nd R-boost]
Stall prevention level	FU1-60 [Stall Level]	APP-26 [2nd Stall]
ETH level for 1 minute	FU1-61 [ETH 1min]	APP-27 [2nd ETH 1min]
ETH level for continuous	FU1-62 [ETH cont]	APP-28 [2nd ETH cont]
Motor rated current	FU2-43 [Rated-Curr]	APP-29 [2nd R-Curr]

The 1st functions are applied if the assigned multifunction terminal is not defined as '2nd Func' nor ON. The 2nd function parameters are applied when the multifunction input terminal set to '2nd Func' is ON. Parameters not listed on the table above are same as the 1st function.

Note: Exchange the motor connection from the 1st motor to the 2nd motor or the opposite when the motor is stopped. Over voltage or over current fault may occur when the motor is exchanged during operation.

Note: The 'User V/F' function of FU1-40 [V/F Pattern] is commonly used for the 1st and the 2nd motor.

APP-40: Number of Running Auxiliary Motor Display

APP-40~APP-71: MMC Operation Control

APP▶ Aux Mot Run		
40	0	

40	0
----	---

Factory Default:	0	0
------------------	---	---

This code shows how many auxiliary motors are run by MMC control.

[MMC]: The 'PID' control should be selected in APP-02 to use this function.

- ◆ One inverter can control multiple motors. This function is often used when controlling the rate and pressure of flow in fans or pumps. Built-in PI controller controls a main motor after receiving process control feedback value and keeps the control value constant by connecting auxiliary motors to commercial line when needed.

- ◆ In case that flow rate or flow pressure is beyond or below the reference so the main motor cannot control by itself, auxiliary motors are automatically turned on/off. Maximum four (Aux.1-4 output) auxiliary motors can be run. Each of Starting and Stop Frequency should be set for automatically running four auxiliary motors.

- ◆ **Auto Change** can be selected to automatically switch the order of the running motors for keeping motor run-time constant. Set mode '1' for automatic changing of auxiliary motors only and set mode '2' for automatic changing of all motors including main motor. For mode '2', APP-67/68 should be set and external sequence (Refer to APP-20~29) should be configured.

- ◆ Abnormal motor can be skipped from running by using the Programmable digital input terminals (M1, M2, M3, and M4). If a Programmable digital terminal (M1, M2, M3 and M4) is opened, the inverter stops all running motors and restarts operation with only normal motors except the abnormal (Off) motor. (Refer to APP-69)

- ◆ Sleep function is initiated when flow demand is low. Inverter stops the motor when the motor runs below Sleep Frequency after Sleep Delay Time. While in the sleep state, inverter keeps monitoring and initiates Wake-Up function when the real value (feedback) of the controlling amount has decreased below the Wake-Up level.

Note: Only one auxiliary motor can be connected with AUX terminal on control terminal strip without using MMC Option Board.

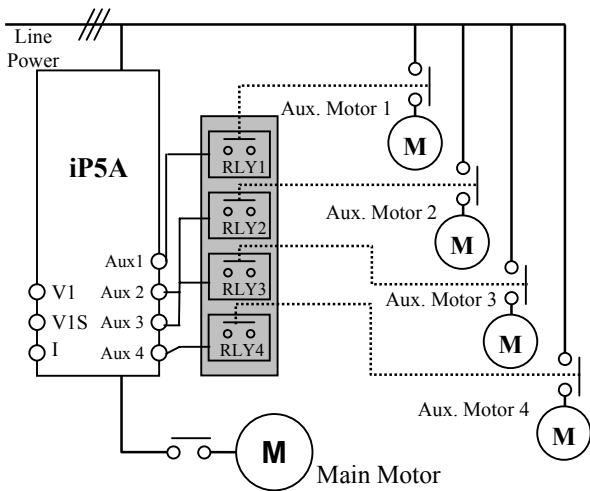

[MMC Diagram]

APP-41: Starting Auxiliary Motor Selection

APP▶ Starting Aux 41 1	41	1
Factory Default: 1		1

This code defines the starting auxiliary motor for MMC control.

APP-42: Operation Time Display on Auto Change

APP▶ Auto Op Time 42 00:00	42	00:00
Factory Default: 00:00		00:00

This code displays the operation time after Auto Change is accomplished.

APP-43: The Number of Aux. Motors

APP▶ Nbr Aux's 43 4	43	4
Factory Default: 4		4

Sets the number of auxiliary motors connected to the inverter.

APP-44-50: Start Frequency of Aux. Motor 1~7

APP▶ Start freq1 44 49.99 Hz	44	49.99
Factory Default: 49.99 Hz		49.99

APP▶ Start freq2 45 49.99 Hz	45	49.99
Factory Default: 49.99 Hz		49.99

APP▶ Start freq6 49 49.99 Hz	49	49.99
Factory Default: 49.99 Hz		49.99

APP▶ Start freq7 50 49.99 Hz	50	49.99
Factory Default: 49.99 Hz		49.99

The inverter turns on AUX1, AUX2, AUX3, and AUX4 if the output frequency is over the frequencies set in APP-44 to APP-50, respectively, the time is over APP-58 and pressure difference between reference and feedback value exceeds the value set in APP-71 [Actual Pr Diff].

APP-51~57: Stop Frequency of Aux. Motor 1~7

APP▶ Stop freq1 51 20.00 Hz	51	20.00
Factory Default: 20.00 Hz		20.00

APP▶ Stop freq2 52 20.00 Hz	52	20.00
Factory Default: 20.00 Hz		20.00

APP▶ Stop freq3 56 15.00 Hz	56	15.00
Factory Default: 15.00 Hz		15.00

APP▶ Stop freq4 57 15.00 Hz	57	15.00
Factory Default: 15.00 Hz		15.00

The inverter turns off AUX4, AUX3, AUX2 and AUX1 in this order if the output frequency is below the frequencies set in APP-51 to APP-57, respectively, the time is over APP-59 and the pressure difference between reference and feedback value decreases below the set value set in APP-71 [Actual Pr Diff].

APP-58: Delay Time before Starting Aux. Motor
APP-59: Delay Time before Stopping Aux. Motor
APP-60, 61: Accel/Decel time when the number of pumps is increasing/decreasing

APP▶ Aux Start DT 58 5.0 sec	58	5.0
-------------------------------------	-----------	------------

Factory Default: 5.0 sec **5.0**

Sets the time the inverter waits before starting the auxiliary motors.

APP▶ Aux Stop DT 59 5.0 sec	59	5.0
------------------------------------	-----------	------------

Factory Default: 5.0 sec **5.0**

APP▶Pid AccTime 60 2.0 sec	60	2.0
-----------------------------------	-----------	------------

Factory Default: 2.0 sec **2.0**

APP▶Pid DecTime 61 2.0 sec	61	2.0
-----------------------------------	-----------	------------

Factory Default: 2.0 sec **2.0**

Sets the time the inverter waits for the input before stopping the auxiliary motors.

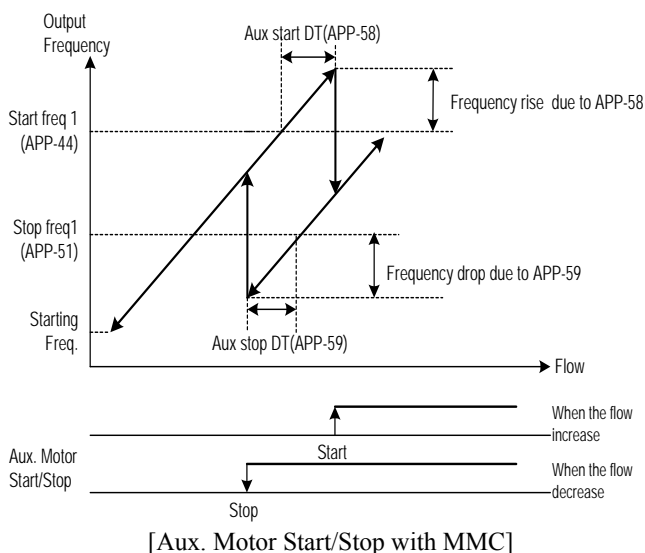

APP-60 and APP-61 sets the acceleration/ deceleration time of the Main motor by 0.1 sec when more/less aux motors are connected.

APP-62: PID Bypass Selection

APP▶ Regul Bypass 62 No	62	0
--------------------------------	-----------	----------

Factory Default: No **0**

This is used to bypass the PID operation selected in APP-02. Select this code to 'Yes' when using MMC function without PID control. The frequency is determined by actual value (feedback) of control amount instead of PID controller output. The actual value is also used as the Start/Stop reference of Aux. motors.

The following figure shows the running pattern with this function applied for controlling the flow rate of a tank. To control the flow rate proportional to the water level of a tank, divide the water level in the tank into the region for the number of Aux. motors plus one, and map each region by starting frequency to maximum frequency. The inverter increases output frequency to lower the water level in the tank when the water level in the tank rises. When reaching maximum frequency, inverter connects aux. motors connected directly to commercial line. After connecting aux. motor, inverter starts again from the starting frequency. By selecting APP-61 [Regul Bypass] to 'Yes', PID operation is disabled and Control Mode is changed to 'V/F'. PID Bypass is available only when DRV-04 [Freq. Mode] is set to 'V1', 'I' or 'Pulse'.

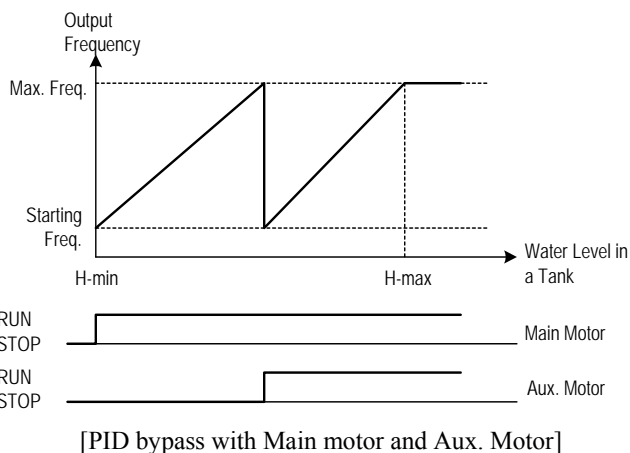

To use MMC operation

- A. Set MMC in APP-01**
- B. Set Process PI to Yes in APP-02**
- C. Set Pre PID operation enable/disable**
 - a. Used for trial operation to check such as pipe damage before operation.
 - b. Used to know the starting set point before PID operation
 - c. Related Code: APP-74,75,76
- D. Set PID target value input method in APP-04**
 - a. Keypad, V1, I ...
 - b. Set target value
- E. Set PID Feedback input method in APP-06**
 - a. Set according to sensor used.
 - b. Analog input (4~20mA, 0~10V ...)
 - c. Check whether the setting performs well.
 - i. Pre-operation is needed.
 - ii. Checks whether output to feedback value is generated.
- F. Set Multi-motor driving sequence in APP-66**
 - a. Mode 0,1: Main motor and Aux motor used
 - i. Available motor: Main motor 1 + Aux motor 4 (+3 when Option is used)
 - b. Mode 2: Aux motor used
 - ii. Available motor: Aux motor 4 (+3 when Option is used)
- G. Set the number of Aux motor in APP-43**
- H. Set the starting Aux motor in APP-41**
- I. Set the start freq of Aux motor in APP-44~50**
- J. Set the stop freq of Aux motor in APP-51~57**
- K. Start operation.**

Detailed MMC function setting

- Energy-saving under light load**
 - Sleep, Wake up
- B. To easily and effectively use Process PID operation**
 - Pre PID
- C. To divide the load to the motor equally**
 - Auto Change
- D. To associate other conditions with Aux motor operation**
 - INTERLOCK
- E. Adjusting Aux motor ON/OFF condition and output (pressure, air/wind volume) variation**
- F. To change response characteristics**
 - It is related to PID control. Refer to Process PID description.

APP-63: Sleep Delay Time	APP-64: Sleep Frequency	APP-65: Wake-Up Level
--------------------------	-------------------------	-----------------------

APP▶ Sleep Delay 63 60.0 sec	63	60.0
--------------------------------------	-----------	-------------

Factory Default: 60.0 sec	60.0
---------------------------	-------------

APP▶ Sleep Freq 64 0.00 Hz	64	0.00
------------------------------------	-----------	-------------

Factory Default: 0.00 Hz	0.00
--------------------------	-------------

APP▶ WakeUp level 65 2.0 %	65	2.0
------------------------------------	-----------	------------

Factory Default: 2.0 %	2.0
------------------------	------------

Sleep function is initiated when flow demand is low. Inverter stops motor when the motor runs below Sleep Frequency (APP-64) during Sleep Delay Time (APP-63). While in the sleep state, the drive keeps monitoring and controlling, and initiates the Wake-Up function when the real value of the controlling amount is greatly different from the Wake-Up level (APP-65) based on Target Level.

Note: Sleep function is not operated if the Sleep Delay Time (APP-63) is set to '0'.

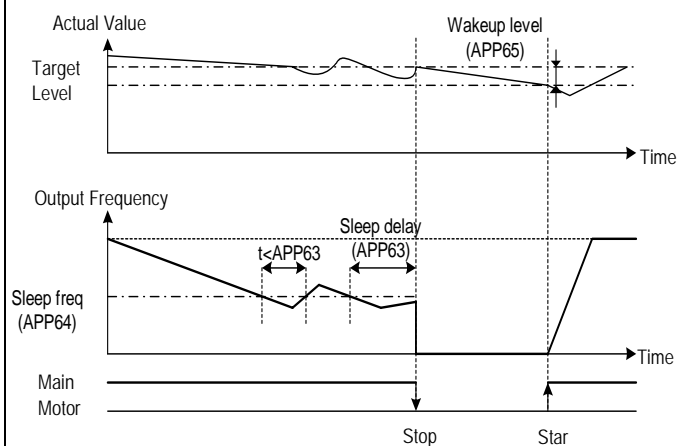

[Sleep Operation]

APP-66: Auto Change Mode Selection

APP▶ AutoCh_Mode
66 0

66

0

Factory Default: 0

0

This function is used to change the running order of the motors to regulate their run-time when multiple motors are connected for MMC.

[0]: Not using Auto Change Function.

The inverter is driving the main motor, and tuning the relays ON to connect Aux motors. For example, starting from the Aux motor 3, inverter turns the relays ON from **RLY3 RLY4 RLY1 RLY2** and turns off the aux motors oppositely from **RLY2 RLY1 RLY4 RLY3**.

[1]: Auto Change Function is applied only to aux. motors. On/Off sequence is the same as **Mode [0]**. However, the difference is that starting Aux motor is fixed in **Mode [0]** but it is automatically changed by inverter in **Mode [1]** to prevent a specific motor from overusing. For example, when Aux motors running order is **RLY1 RLY2 RLY3 RLY4** and then the Auto change condition is met, inverter turns the relay On from **RLY 2 RLY3 RLY4 RLY1**.

→ **Mode [0], [1] are available when a Main motor is directly connected to the Inverter.**

[2]: Auto Change of Main/Aux motors.

All motors are connected to relays and operated via relays. The operation procedure is the same as **Mode [1]**, except that there is no main motor directly connected to Inverter.

APP-67: Auto Change Time
APP-68: Auto Change Level

APP▶ AutoEx-intv
67 72:00

67

72:00

Factory Default: 72:00

72:00

APP▶ AutoEx-level
68 20.00 Hz

68

20.00

Factory Default: 20.00 Hz

20.00

This function is used to protect motor from running alone for a long time by changing operation to other motor.

Auto Change is accomplished when the following conditions are satisfied:

- 1) The time set in APP-67 is over.
- 2) The actual value of controlling amount is less than the value set in APP-68.
- 3) All Aux motors Off (in **Mode 1**)
- 3) One motor is running (in **Mode 2**).

When above three conditions are met, the inverter stops the running motor, and changes motor to run by the order set in APP-66 and then continues operation according to new order. Inverter starts counting only when auxiliary motor is running.

In Mode 2, when inverter output frequency is below Auto Change Level, inverter automatically stops the motor and perform Auto change function and operates next motor.

Please refer to the wiring example below when Interlock is used during Auto change Mode 2.

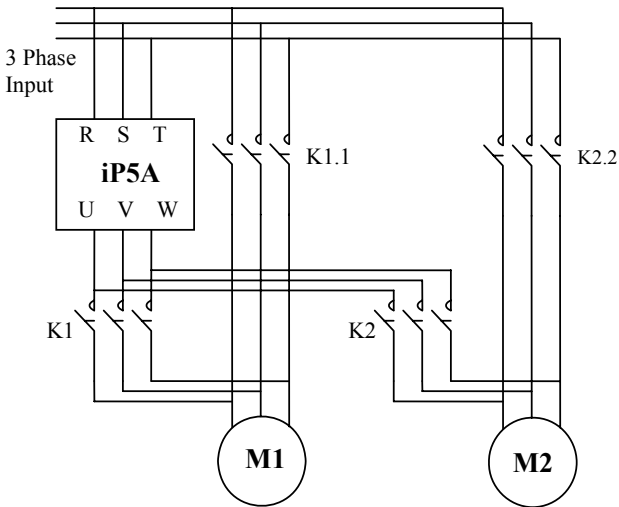

[Wiring Diagram for Inter-Lock Configuration]

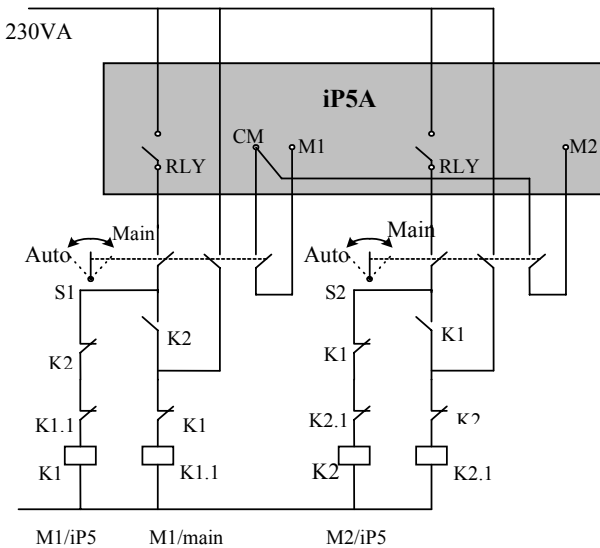

[Sequence Circuit for Inter-Lock Configuration]

APP-69: Interlock Selection

APP▶ Inter-lock	69	0
69 No		
Factory Default: No		0

When APP-69 [Interlock selection] is set to “Yes”, M1~M4 can be used as the same activating condition for AX1~AX4. Programmable digital input terminals are activated when turned ON. If one of them are turned Off, all motors will start running except the motor connected to the off terminal. If the input signal is turned off in the midst of running, inverter stops all the motors and restarts the operation with normal active motors.

Interlock during Stop

When Run signal is input during Stop, MMC operation is started with the Aux motors(Relays) turned ON.

Ex) When Interlock is not selected:

RLY1→RLY2→RLY3→RLY4

When Interlock is active (the terminal defined as Interlock/RLY2 is turned Off):

RLY1→ RLY3→RLY4

Interlock during RUN

When Interlock is active during RUN (the terminal defined as interlock/RLY is turned Off during RUN), inverter stops all motors and restart MMC operation with aux motors except the interlocked one(terminal turned Off).

Ex)Normal operation:

RLY1→RLY2→RLY3→RLY4

When Interlock is active (the terminal defined as Interlock/RLY3 is turned OFF), all Aux motors are turned Off and stopped. MMC operation is restarted except Aux motor 3 (RLY 3 Off).

Aux motors start rotating in the order of

RLY1→RLY2→RLY4.

Aux motor starting condition and output
(Pressure, air volume..) adjustment

Inverter turns Aux motors ON automatically when it is impossible for a main motor to control increased load, causing shortage in flow rate or flow pressure. Maximum 4 Aux motors can be used. To turn on the 4 Aux motors automatically, starting frequency for each motor should be set. (7 motors available with option board).

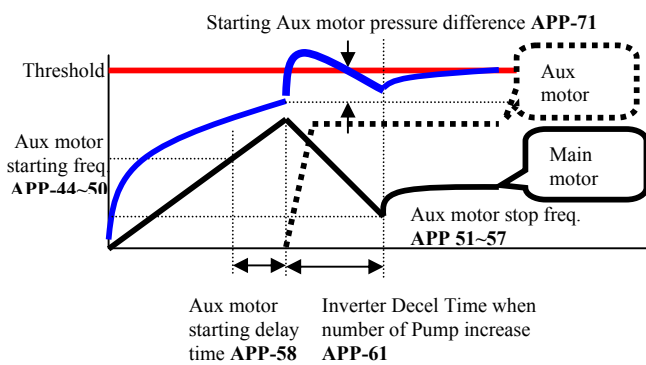

Aux motor active condition: Main motor speed exceeds Aux motor starting frequency (APP-44~50), for the time over APP-58[Aux motor starting delay time], Difference between PID reference and Feedback value exceeds APP-71 [Starting Aux motor pressure difference].

APP-44~50: Frequency to turn Aux motor ON. It is set the same as main motor frequency outputting equally when aux motor is turned ON.

APP-58: It should be set greater than system delay time.

APP-71: It is set by comparing the pressure difference when Aux motor is turned ON and that of Aux motor starting frequency.

APP-61: This is the time inverter frequency is decreased after Aux motor is turned ON. It should be set higher than System delay time but it causes Aux motor ON state to become too long.

Aux motor stopping condition and output
(Pressure, air volume..) adjustment

Inverter turns off the Aux motors when flow rate or flow pressure is too large due to decreased load. For Inverter to turn off Max 4 Aux motors automatically, 4 stopping frequency should be set separately. (7 motors available with Option board)

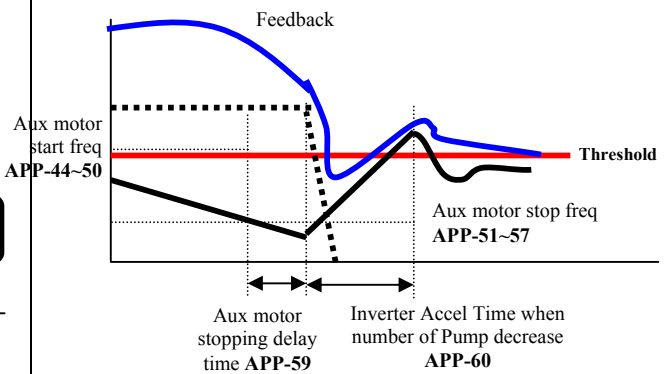

Aux motors are opened when main motor rotates below APP-51~57 [Aux motor stopping frequency] for the time over APP-59 [Aux motor stopping delay time] and pressure difference between PID reference and Feedback value exceeds the set value in APP-71[Aux motor starting /stopping pressure difference].

APP-51~57: The Aux motors are turned off at this frequency. It is set as dF, whose output matches when Aux motor is off.
 (dF = Aux motor On Freq – Aux motor Off Freq)

APP-59: It should be set higher than System Delay Time.

APP-60: This is the time inverter frequency is increased after Aux motor is turned OFF. It should be set higher than System delay time but it causes Aux motor OFF state to become too long.

APP-71: Pressure Difference for Aux Motor Stop

APP▶ Aux Pr Diff 71 2%	71	2
--------------------------------------	-----------	----------

Factory Default: 2%	2
---------------------	----------

It sets the pressure difference between when Aux motors are ON and Aux motor starting frequency.

APP-74, 75, 76: Pre PID Operation (Freq. Exit, Delay)

APP▶ PrePID Freq 74 0.00 Hz	74	0.00
---	-----------	-------------

Factory Default: 0.00 Hz	0.00
--------------------------	-------------

APP▶ PrePID Exit 75 0.0 %	75	0.0
---	-----------	------------

Factory Default: 0.0 %	0.0
------------------------	------------

APP▶ PrePID dly 76 600 sec	76	600
--	-----------	------------

Factory Default: 600 sec	600
--------------------------	------------

Pre PID operation is a new function for smooth PID operation. For example, before pump operation is started, Pre PID fills water in the pump and pipe. Or Accel/Decel operation is performed before coil winding machine's speed reaches a certain level.

- APP-74 [Frequency before PID operation begins]

It is the inverter target frequency to be output until Pre PID operation is finished when Inverter Run signal is ON and Pre PID operation is selected.

- APP-75 [condition to activate PID operation]
User sets the value which is considered enough to start PID operation compared to feedback value during Pre PID operation. If the feedback value exceeds the set value in APP-75, Pre PID operation ends and PID operation begins.

- APP-76 [Pre PID delay time]

When feedback value is less than APP-75 value even

though time set in APP-76 elapses, inverter signals system malfunction. It is also user-settable to fit for the system in use.

APP-80~97: External PID operation

APP▶ Ext Ref Sel 81 KeyPad	81	3
--	-----------	----------

Factory Default: KeyPad	3
-------------------------	----------

APP▶ Ext Ref Perc 82 50.00%	82	50.00
---	-----------	--------------

Factory Default: 50.00%	50.00
-------------------------	--------------

-
-
-

Code	LCD Display	Default	Range
APP-80	Ext PI mode	0 (No)	0 (No) 1 (Yes)
APP-81	Ext Ref Sel	3 (Key-Pad)	0 (I) 1 (V1) 2 (Pulse) 3 (Key-Pad)
APP-82	Ext Ref Perc	50.00 [%]	0 – 100.00 [%]
APP-83	Ext Fbk Sel	0 (I)	0 (I) 1 (V1) 2 (Pulse)
APP-85	ExtPID Pgain	1.0 [%]	0 – 999.9 [%]
APP-86	ExtPID Itime	10.0 [sec]	0 – 32.0 [sec]
APP-87	ExtPID Dtime	0 [msec]	0 – 2000 [msec]
APP-88	ExtPID lmt-H	100.00 [%]	0 – 100.00 [%]
APP-89	ExtPID lmt-L	0.00 [%]	0 – 30.00 [%]
APP-90	ExtPID Scale	100.0 [%]	0 – 999.9
APP-91	Ext P2-gain	100.0 [%]	0 – 999.9
APP-92	Ext P Scale	100.0 [%]	0 – 100.0
APP-93	ExtPID F-gain	0.0 [%]	0 – 999.9 [%]
APP-95	ExtPIDOut Inv	0 (No)	0 (No) 1 (Yes)
APP-97	Ext Loop Time	100 [msec]	50 – 200 [msec]

APP-80~96 setting value is the same as APP-02~17.

APP-82 [Ext PID Ref value] is settable when APP-81 [Ext PID Ref selection] is set to "Keypad".

APP-97 [Ext PID Loop Time] sets the time to activate Ext PID controller. Set the desired value according to system.

Ext PID can be used for controlling other system independently as an external PID controller using both PID controller in APP-02 and External PID controller using Ext PID output as an Inverter target frequency. See 10) APP-02, APP-80 (**to use Dual PID operation**) for more details.

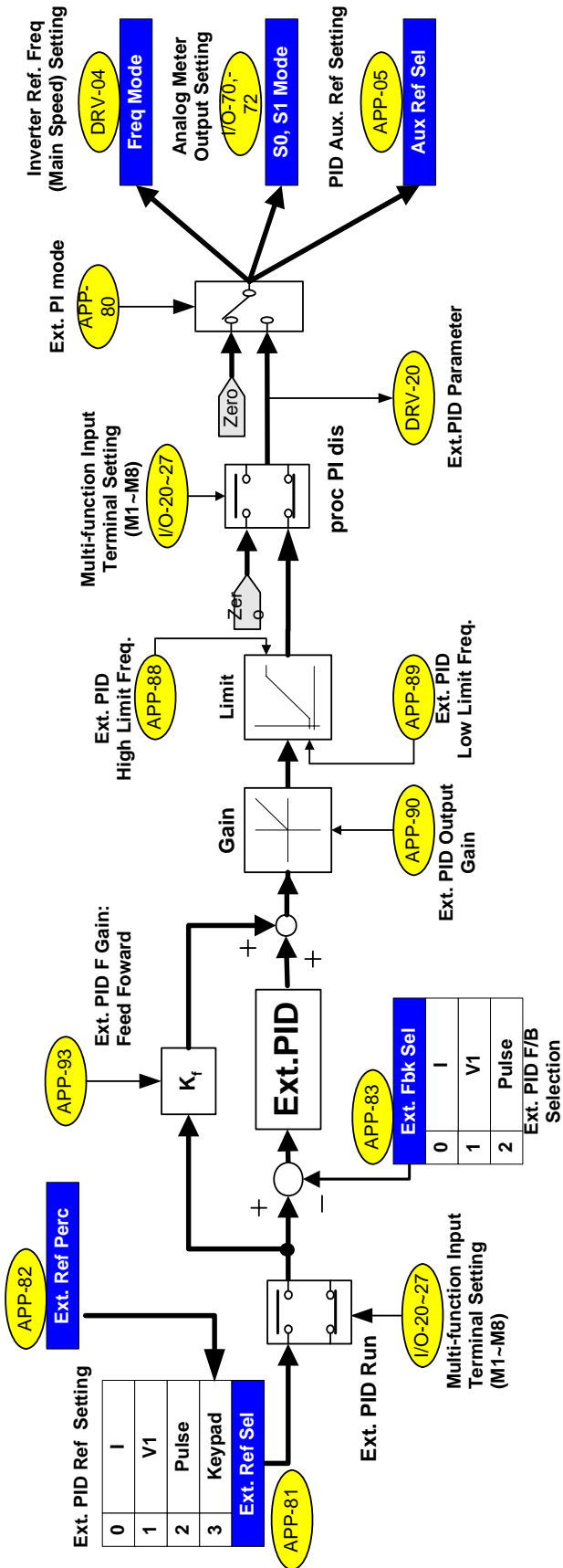

[Ext. PID block diagram]

[Ext. PID internal block diagram]

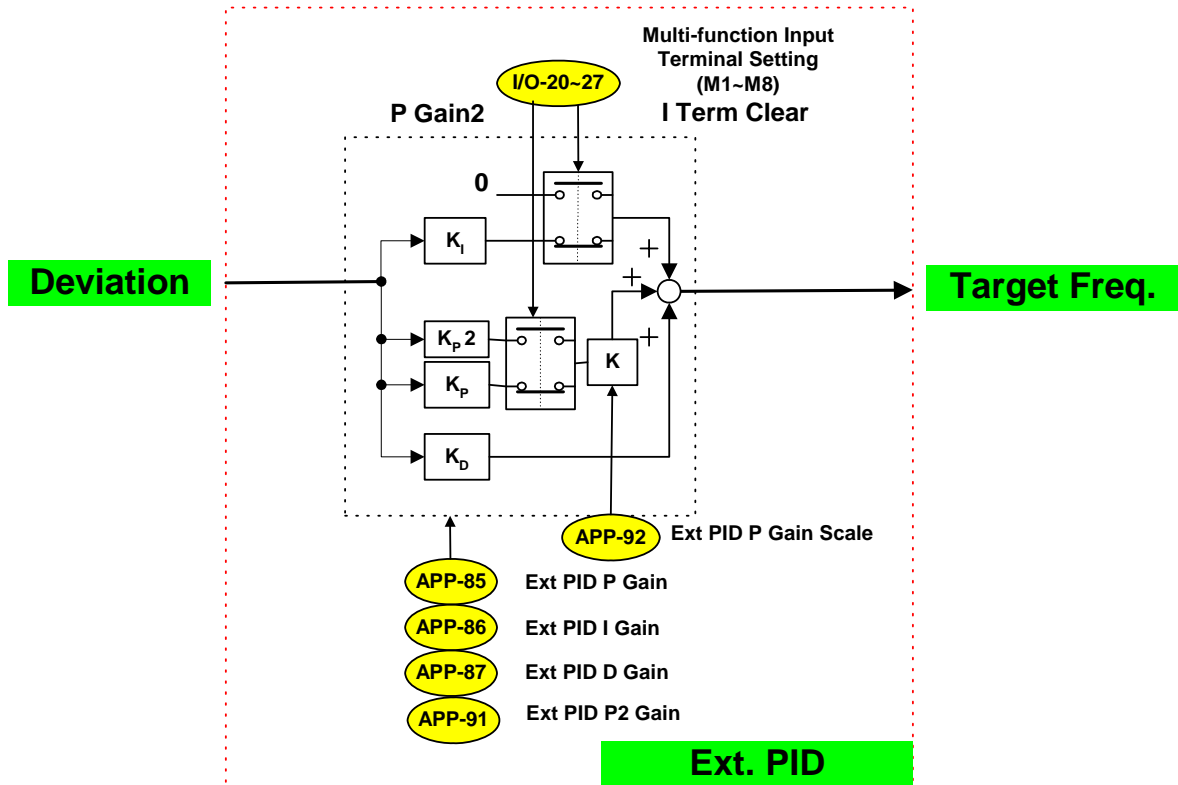

APP-02 , APP-80 (to use Dual PID operation)

ExtPID can be used in the following three cases; controlling other system independently like an external PID controller using both PID controller in APP-02 and External PID controller using ExtPID output as an Inverter target frequency.

[Dual PID block diagram for case]

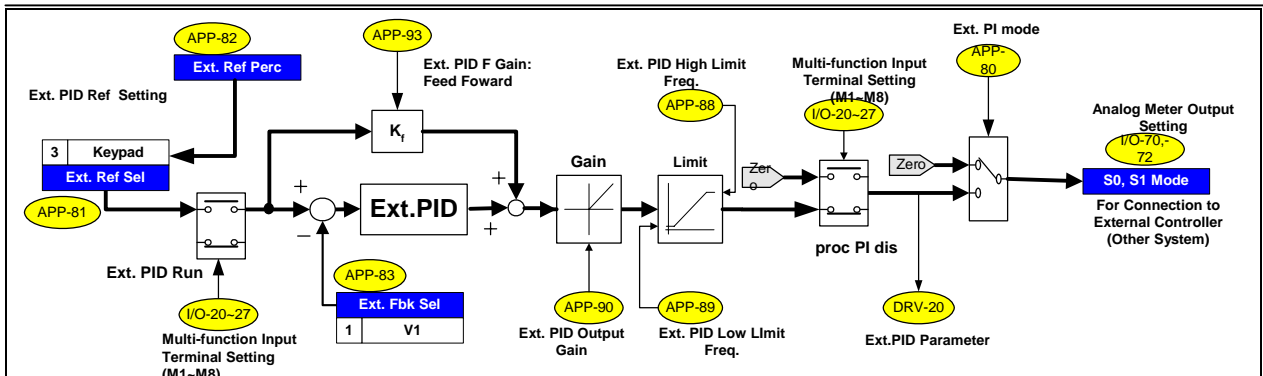

This illustrates controlling other system independently. Set I/O-70 or 72 [S0/S1 mode] to “Ext PID Out” and connect external system to S0 or S1 terminal. When Ext.PID Run signal is ON at the defined terminal in I/O-20~27, it starts output.

[Dual PID block diagram for case]

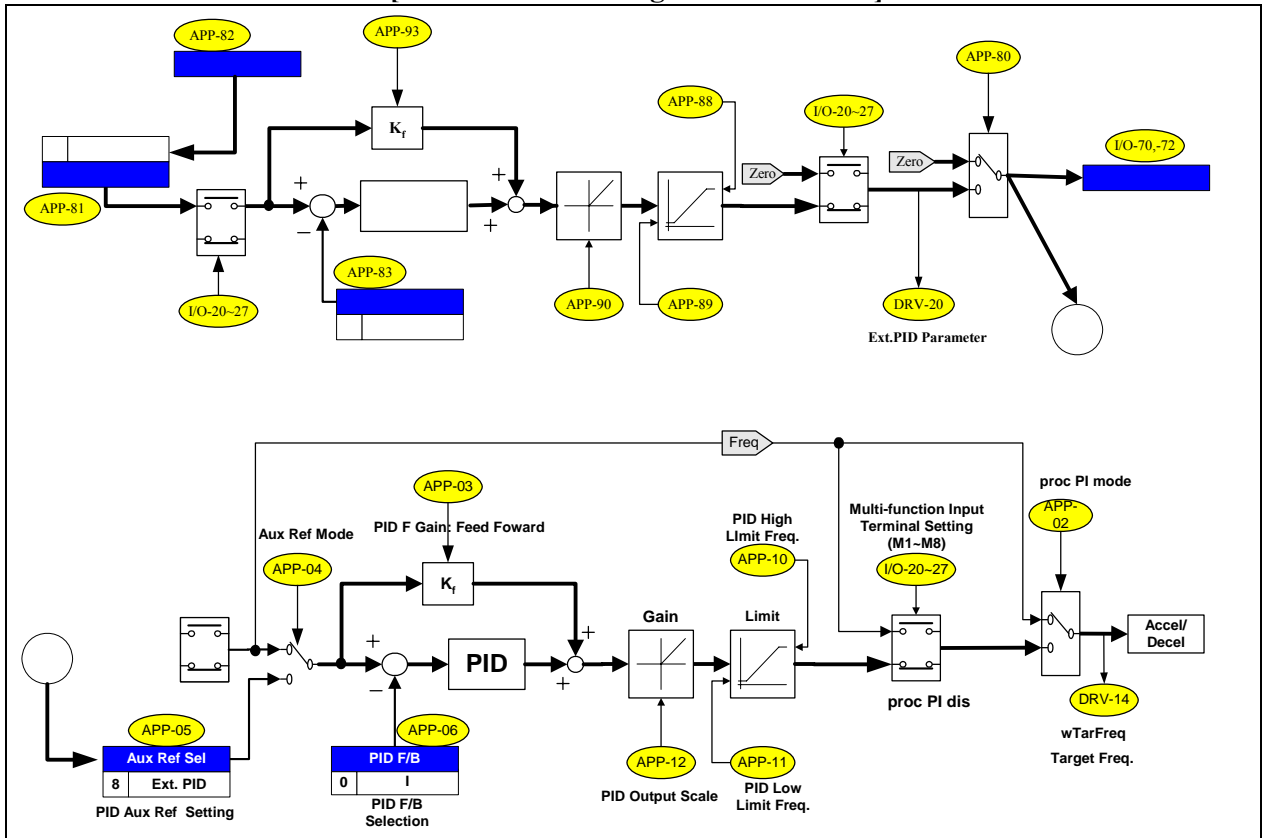

This illustrates dual use of PID controller (APP-02) and External PID controller. Set APP-81 [Ext. Ref Sel] to

Analog Input (V1, I, or Pulse) and perform terminal wiring for analog input. To give the digital reference, set APP-81 [Ext. Ref Sel] to “Keypad” and set proper value in APP-82 [Ext. Ref Perc]. Set the Ext. PID Feedback among V1, I, Pulse in APP-83 and perform terminal wiring for analog input. External PID Ref. and feedback are connected to PID controller. When Ext.PID Run signal is ON to the defined terminal in I/O-20~27, it starts its output. S0/S1 terminal can be used to connect to other system.

[Dual PID block diagram for case]

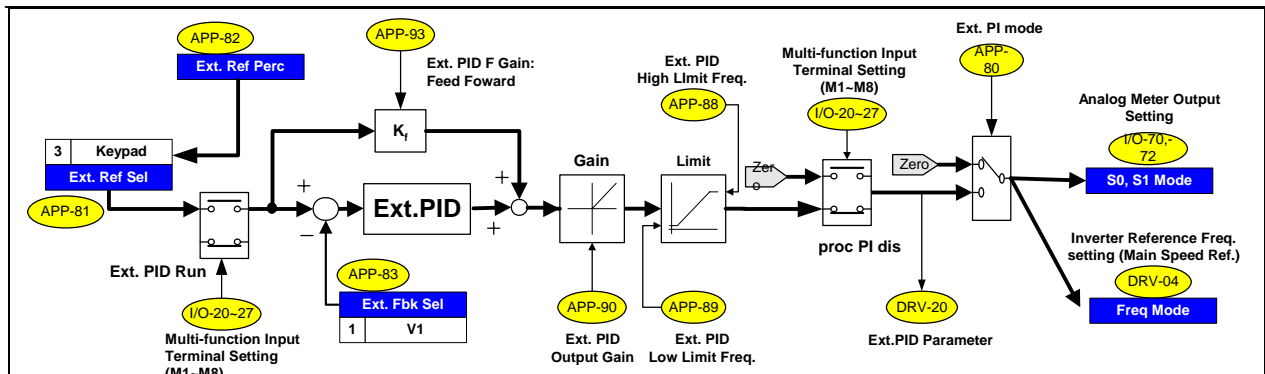

ExtPID output can be used for inverter target frequency. To activate this function, set analog input (V1, I, Pulse) as a reference value to other system or set APP-81 [Ext. Ref Sel] to “Keypad” and set proper value in APP-82 [Ext. Ref Perc]. Set APP-83 [Ext. Fbk Sel] to Analog input (I, V1, Pulse) and conduct wiring. And set DRV-04 [Freq Mode] to “Ext. PID”, then ExtPID output functions as Inverter main speed reference (target frequency). When Ext.PID Run signal is ON in the defined terminal in I/O-20~27, it starts its output and inverter performs Accel/Decel with output frequency. Other system can be connected via S0/S1 terminal.

■ Notes :

CHAPTER 7 - TROUBLESHOOTING & MAINTENANCE

7.1 Fault Display

When a fault occurs, the inverter turns off its output and displays the fault status in DRV-12. The last 5 faults are saved in FU2-01 through FU2-05 with the operation status at the instance of fault.

Keypad Display	Protective Function	Description
Over Current 1	Over Current Protection	The inverter turns off its output when the output current of the inverter flows more than 200% of the inverter rated current.
Ground Fault	Ground Fault Protection	The inverter turns off its output when a ground fault occurs and the ground fault current is more than the internal setting value of the inverter. Over current trip function may protect the inverter when a ground fault occurs due to a low ground fault resistance.
Over Voltage	Over voltage protection	The inverter turns off its output if the DC voltage of the main circuit increases higher than the rated value when the motor decelerates or when regenerative energy flows back to the inverter due to a regenerative load. This fault can also occur due to a surge voltage generated at the power supply system.
Over Load	Current Limit Protection (Overload Protection)	The inverter turns off its output if the output current of the inverter flows at 120% of the inverter rated current.
Over Heat	Inverter Over Heat	The inverter turns off its output if the heat sink is over heated due to a damaged cooling fan or an alien substance in the cooling fan.
E-Thermal	Electronic Thermal	The internal electronic thermal of the inverter determines the over heating of the motor. If the motor is overloaded the inverter turns off the output. The inverter cannot protect the motor when driving a multi-pole motor or when driving multiple motors, so consider thermal relays or other thermal protective devices for each motor. Overload capacity: 130% for 1 min
Ext. Trip	External Trip	Use this function if the user needs to turn off the output by an external trip signal. (Normal Open Contact) Inverter blocks the output to protect motor overload by detecting through this terminal.
Low Voltage	Low Voltage Protection	The inverter turns off its output if the DC voltage is below the detection level because insufficient torque or over heating of the motor can occurs when the input voltage of the inverter drops.
Over Current 2	IGBT Short	The inverter turns off the output if an IGBT short through or an output short occurs.
Output Phase Open	Output Phase open	The inverter turns off its output when the one or more of the output (U, V, W) phase is open. The inverter detects the output current to check the phase open of the output.
BX	BX Protection (Instant Cut Off)	Used for the emergency stop of the inverter. The inverter instantly turns off the output when the BX terminal is turned ON, and returns to regular operation when the BX terminal is turned OFF. Take caution when using this function.
HW-Diag	Inverter H/W Fault	A fault signal is output when an error occurs to the control circuitry of the inverter. There are the Wdog error, the EEP error, Input phase open, NTC open and the ADC Offset for this fault
COM Error CPU Error	Communication Error	This fault is displayed when the inverter cannot communicate with the keypad.
Inv. OLT	Inverter Overload	The inverter turns off its output when the output current of the inverter flows more than the rated level (110% for 1 minute, 130% for 4 seconds).
NTC open	NTC Open	This fault is displayed when inverter internal NTC is opened.

Chapter 7 - Troubleshooting & Maintenance

Keypad Display	Protective Function	Description
LOP LOR LOV LOI LOX	Operating Method when the Frequency Reference is Lost	According to the I/O-48 [Operating Method when the Frequency Reference is Lost] setting, there are three modes: continuous operation, decelerate to stop, and free run, LOP: Displayed when option frequency reference is lost (DPRAM time out) LOR: Displayed when option frequency reference is lost (Communication network fault) LOV: Displayed when 'V1' analog frequency reference is lost. LOI: Displayed when 'I' analog frequency reference is lost. LOX: Displayed when sub-board (V2, ENC) analog frequency reference is lost.

To reset fault, Press **RESET** key, close RST-CM terminals or cycle the input power.

If a problem persists, please contact the factory or your local distributor.

Fault Remedy

Protective Function	Cause	Remedy
Over Current Protection 1	Acceleration/Deceleration time is too short compared to the GD of the load. Load is larger than the inverter rating. Inverter turns output on when the motor is free running. Output short or ground fault has occurred. 5) Mechanical brake of the motor is operating too fast. 6) Components of the main circuit have overheated due to a faulty cooling fan.	1) Increase Accel/Decel time. 2) Increase inverter capacity. 3) Operate after motor has stopped. 4) Check output wiring. 5) Check mechanical brake operation. 6) Check cooling fan. (Caution) Operating inverter prior to correcting fault may damage the IGBT.
Ground Fault Current Protection	Ground fault has occurred at the output wiring of inverter. The insulation of the motor is damaged due to heat.	Investigate the output wiring of inverter. Exchange motor.
Over Voltage Protection	ompared to the GD of load. Regenerative load at the output Line voltage high	Increase deceleration time. Use regenerative resistor option. Check line voltage.
Current Limit Protection (Overload Protection)	Load is larger than the inverter rating. Incorrect inverter capacity selected. Set incorrect V/F pattern.	Increase capacity of motor and inverter. Select correct inverter capacity. Select correct V/F pattern.
Inverter Overheat	Cooling fan damaged or an alien substance inserted. Cooling system has faults. Ambient temperature high.	Exchange cooling fans and/or eliminate alien substance. Check for alien substances in the heat sink. Keep ambient temperature under 40 .
Electronic Thermal	Motor has overheated. Load is larger than inverter rating. ETH level too low. Incorrect inverter capacity selected. Set incorrect V/F pattern. Operated too long at low speeds.	Reduce load and/or running duty. Increase inverter capacity. Adjust ETH level to an appropriate level. Select correct inverter capacity. Select correct V/F pattern. Install a cooling fan with a separate power supply.
External Trip	External Trip has occurred.	Eliminate Trip at circuit connected to external trip terminal or remove external trip input.
Low Voltage Protection	Line voltage low. Load larger than line capacity is connected to line. (welding machine, motor with high starting current connected to the commercial line) Faulty magnetic switch at the input side of the inverter	Check line voltage. Increase line capacity. Exchange magnetic switch.
Over Current 2	Short has occurred between the upper and lower IGBT. Short has occurred at the output of the inverter. Acceleration/Deceleration time is too short compared to the GD of load.	Check IGBT. Check output wiring of inverter. Increase acceleration time.
Output Phase Open	Faulty contact of magnetic switch at output Faulty output wiring	Check magnetic switch at output of inverter. Check output wiring.
H/W Fault	Wdog error (CPU fault) EEP error (memory fault) ADC Offset (current feedback circuit fault)	Exchange inverter.
Communication Fault	Faulty connection between inverter and keypad Inverter CPU malfunction	Check connector. Exchange inverter.

Chapter 7 - Troubleshooting & Maintenance

Protective Function	Cause	Remedy
Operating Method when the Speed Reference is Lost	LOP (Loss of reference from the Option), LOR (Remote) LOV (V1), LOI (I), LOX (Sub-V2, ENC)	Eliminate cause of fault.
Inverter Overload	Load is larger than inverter rating. Incorrect inverter capacity selected.	Increase motor and/or inverter capacity. Select correct inverter capacity.

7.2 Troubleshooting

Condition	Checking Point
The Motor Does Not Rotate.	1) Main circuit inspection: Is the input (line) voltage normal? (Is the LED in the inverter is lit?) Is the motor connected correctly? 2) Input signal inspection: Check the operating signal input to the inverter. Check the forward and the reverse signal input simultaneously to the inverter? Check the command frequency signal input to the inverter. 3) Parameter setting inspection: Is the reverse prevention (FU1-01) function set? Is the Drive mode (DRV-03) set correctly? Is the command frequency set to 0? 4) Load inspection: Is the load too large or is the motor jammed? (Mechanical brake) 5) Other: Is the alarm displayed on the keypad or is the alarm LED lit? (STOP LED blinks)
The Motor Rotates in Opposite Directions.	Is the phase sequence of the output terminal U, V, W correct? Is the starting signal (forward/reverse) connected correctly?
The Difference Between the Rotating Speed and the Reference is Too Large.	Is the frequency reference signal correct? (Check the level of the input signal) Is the following parameter setting is correct? Lower Limit Frequency (FU1-34), Upper Limit Frequency (FU1-35), Analog Frequency Gain (I/O-1~10) Is the input signal line influenced by external noise? (Use a shielded wire)
The Inverter Does Not Accelerate or Decelerate Smoothly.	Is the acceleration/deceleration time is set too short a period of time? Is the load too large? Is the Torque Boost (FU2-68, 69) value is too high that the current limit function and the stall prevention function do not operate?
The Motor Current is Too High.	Is the load too large? Is the Torque Boost Value (manual) too high?
The Rotating Speed Does Not Increase.	Is the Upper Limit Frequency (FU1-35) value correct? Is the load too large? Is the Torque Boost (FU1-68, 69) value too high that the stall prevention function (FU1-70, 71) does not operate?
The Rotating Speed Oscillates When the Inverter is Operating.	1) Load inspection: Is the load oscillating? 2) Input signal inspection: Is the frequency reference signal oscillating? 3) Other: Is the wiring too long when the inverter is using V/F control? (over 500m)

7.3 How to Check Power Components

1) Diode module and IGBT module check (5.5~ 30kW)

Before checking the power components, be sure to disconnect AC Input supply and wait until the Main Electrolytic Capacitors (DCP-DCN) is discharged.

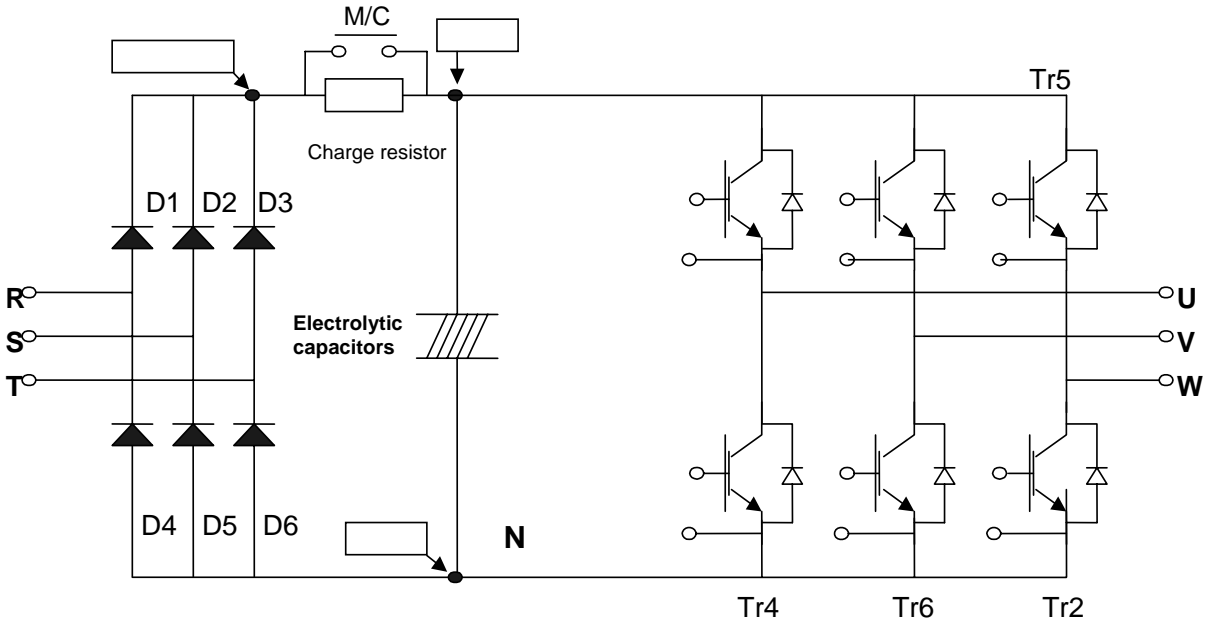

- Turn the power off and disconnect RST/UVW wiring.
- Determine whether inverter terminals (R,S,T, U, V, W, P1(or P2),N) are energized or not using a tester.
- Wait until the Main Electrolytic Capacitors (DCP-DCN) is discharged to a safe level.
- Enormous amount of value such as Mega will be displayed when Open. When closed, the resistance value ranges from a few ohms to tens of Ω. Sometimes, it seems to be closed due to electrolytic capacitors but soon to be displayed mega value resistance.
- The displayed value is not always the same according to modules and tester types but should be similar.
- Modules number and checking point

Module		Test polarity		Check value	Number	Test polarity		Check value
		+	-			+	-	
Diode	D1	R	DCP+	Closed	D4	R	N	Open
		DCP+	R	Open		N	R	Closed
	D2	S	DCP+	Closed	D5	S	N	Open
		DCP+	S	Open		N	S	Closed
	D3	T	DCP+	Closed	D6	T	N	Open
		DCP+	T	Open		N	T	Closed
IGBT	Tr1	U	DCP	Closed	Tr4	U	N	Open
		DCP	U	Open		N	U	Closed
	Tr3	V	DCP	Closed	Tr6	V	N	Open
		DCP	V	Open		N	V	Closed
	Tr5	W	DCP	Closed	Tr2	W	N	Open
		DCP	W	Open		N	W	Closed

2) Diode module and IGBT module check (37~ 90kW)

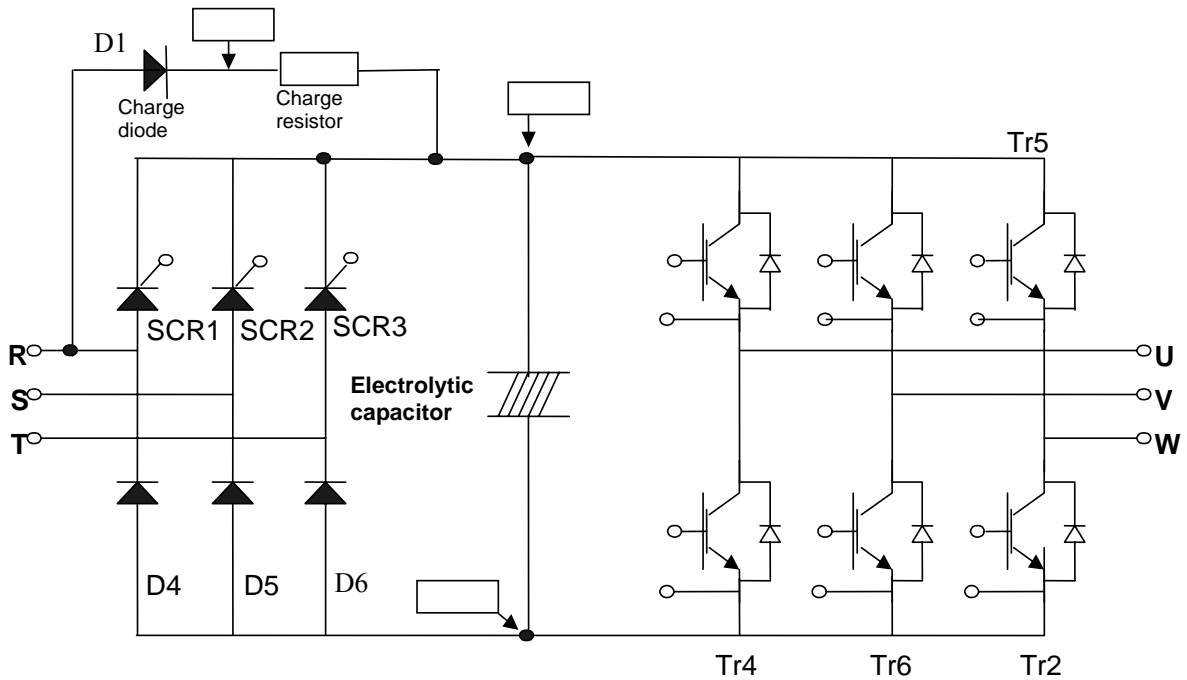

- Turn the power off and disconnect RST/UVW wiring.
- Determine whether inverter terminals (R,S,T, U, V, W, P1(or P2),N) are energized or not using a tester.
- Wait until the Main Electrolytic Capacitors (DCP-DCN) is discharged to a safe level.
- Enormous amount of value such as Mega will be displayed when Open. When closed, the resistance value ranges from a few ohms to tens of Ω . Sometimes, it seems to be closed due to electrolytic capacitors but soon to be displayed mega value resistance.
- The displayed value is not always the same according to modules and tester types but should be similar.
- Modules number and checking point

Module		Test polarity		Check value	Number	Test polarity		Check value
		+	-			+	-	
Diode	D1	R	DCP+	Closed	D4	R	N	Open
		DCP+	R	Open		N	R	Closed
	D5	S	N	Open	D6	T	N	Open
		N	S	Closed		N	T	Closed
IGBT	Tr1	U	DCP	Closed	Tr4	U	N	Open
		DCP	U	Open		N	U	Closed
	Tr3	V	DCP	Closed	Tr6	V	N	Open
		DCP	V	Open		N	V	Closed
	Tr5	W	DCP	Closed	Tr2	W	N	Open
		DCP	W	Open		N	W	Closed

7.4 Maintenance

The iP5A series is an industrial electronic product with advanced semiconductor elements. However, temperature, humidity, vibration and aging parts may still affect it. To avoid this, it is recommended to perform routine inspections.

7.4.1 Precautions

Be sure to remove the drive power input while performing maintenance.

Be sure to perform maintenance only after checking that the bus has discharged (The voltage between terminal P1-N (or P2-N) should be less than DC 30V). The bus capacitors in the electronic circuit can still be charged even after the power is turned off.

The correct output voltage can only be measured by using a rectifier voltage meter. Other voltage meters, including digital voltage meters, are likely to display incorrect values caused by the high frequency PWM output voltage of the drive.

7.4.2 Routine Inspection

Be sure to check the following before operation:

The conditions of the installation location

The conditions of the drive cooling

Abnormal vibration

Abnormal heating

7.4.3 Periodic Inspection

Are there any loose bolt, nut or rust caused by surrounding conditions? If so, tighten them up or replace them.

Are there any deposits inside the drive-cooling fan? If so, remove using air.

Are there any deposits on the drive's PCB (Printed Circuit Boards)? If so, remove using air.

Are there any abnormalities in the various connectors of the drive's PCB? If so, check the condition of the connector in question.

Check the rotating condition of the cooling fan, the size and condition of the capacitors and the connections with the magnetic contactor. Replace them if there are any abnormalities.

7.4.4 Megger/Dielectric Test

Perform megger test after inverter wiring is disconnected. Test voltage should not be applied to the inverter.

Megger test should be conducted only for the main circuit, not the control circuit. Use DC 500V megger.

Dielectric test should not be conducted to the inverter. Otherwise, IGBT may be damaged.

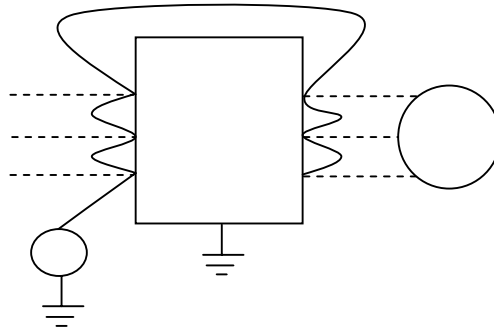

7.4.5 Daily and Periodic Inspection Items

Inspection Location	Inspection Item	Inspection	Period			Inspection Method	Criterion	Measuring Instrument
			Daily	1 year	2 year			
All	Ambient Environment	Is there any dust? Is the ambient temperature and humidity adequate?	O			Refer to the precautions.	Temperature: -10~+40 no freezing. Humidity: Under 50% no dew	Thermometer, Hygrometer, Recorder
	Equipment	Is there any abnormal oscillation or noise?	O			Use sight and hearing.	No abnormality	
	Input Voltage	Is the input voltage of the main circuit normal?	O			Measure the voltage between the terminals R, S, T.		Digital Multi-Meter/Tester
Main Circuit	All	Megger check (between the main circuit and the ground) Are any fixed parts removed? Are there any traces of overheating at each component's cleaning?		O	O	Undo the inverter connections short the terminals R, S, T, U, V, W and measure between these parts and the ground. Tighten the screws. Visual check.	Over 5M No fault	DC 500V class Megger
	Conductor/Wire	Is the conductor rusty? Is the wire coating damaged?		O		Visual check	No fault	
	Terminal	Is there any damage?		O		Visual check	No fault	
	IGBT Module /Diode Module	Check the resistance between each of the terminals.			O	Undo the inverter connection and measure the resistance between R, S, T P, N and U, V, W P, N with a tester.	(Refer 'How to Check Power Components')	Digital Multi-Meter/Analog Tester
	Smoothing Capacitor	Is there any liquid coming out? Is the safety pin out, and is there any swelling? Measure the capacitance.	O	O		Visual check Measure with a capacitance-measuring device.	No fault Over 85% of the rated capacity	Capacitance Measuring Device
	Relay	Is there any chattering noise during operation? Is there any damage to the contact		O		Auditory check Visual check	No fault	
	Resistor	Is there any damage to the resistor insulation? Is the wiring in the resistor damaged (open)?		O		Visual check Disconnect one of the connections and measure with a tester.	No fault Error must be within 10% the displayed resistance.	Digital Multi-Meter/Analog Tester
Control Circuit Protective Circuit	Operation Check	Is there any unbalance between each phases of the output voltage? Nothing must be wrong with display circuit after executing the sequence protective operation.		O	O	Measure the voltage between the output terminals U, V and W. Short and open the inverter protective circuit output.	The voltage balance between the phases for 200V (400V) class is under 4V (8V). The fault circuit operates according to the sequence.	Digital Multi-Meter/Rectifying Voltmeter
Cooling System	Cooling Fan	Is there any abnormal oscillation or noise? Is the connection area loose?	O	O		Turn OFF the power and turn the fan by hand. Tighten the connections.	Must rotate smoothly. No fault	
Display	Meter	Is the displayed value correct?	O	O		Check the meter reading at the exterior of the panel.	Check the specified and management values.	Voltmeter/ Ammeter etc.
Motor	All	Are there any abnormal vibrations or noise? Is there any unusual odor?	O	O		Auditory, sensory, visual check. Check for overheat and damage.	No fault	
	Insulation Resistor	Megger check (between the output terminals and the ground terminal)			O	Undo the U, V and W connections and tie the motor wiring.	Over 5M	500V class Megger

Note: Values in () is for the 400V class inverters.

Note: Life cycle of the Main components indicated above is based on continuous operation with rated load. It may vary with surrounded environment.

7.4.6 Parts replacement

Part name	Period	Comments
Cooling fan	2-3 years	Exchange for a new part after consulting LS A/S center.
Electrolytic capacitor	5 years	Check for the periodic inspection for 1 year. Exchange for a new part after consulting LS A/S center. The Recommended level to exchange a capacitor in main/control circuit is 85% or less of the initial value.
Relays	-	Exchange for a new part after consulting LS A/S center.

The life expectancy of a part depends on the type of part, the environment, and operating conditions.

CHAPTER 8 - OPTIONS

8.1 Option List

External	Keypad	LCD	32 character display keypad Download and Upload available	All units	
	Remote	Remote cable	2m, 3m and 5m long keypad cable enables users to control the inverter from a distant area.	Optional	
	Dynamic braking	DB resistor	Enables inverter to decelerate rapidly.		Optional
		DB unit	DB units are provided as an option from 11 kW.		Optional
	Conduit option	Conduit for NEMA TYPE 1	Install it to fit for NEMA TYPE 1 Enclosure.		15~90kW (20~125HP)

Note) Refer to Option manuals for details.

8.2 External options

8.2.1 Keypad dimensions

1) LCD Keypad (Weight: 140 g)

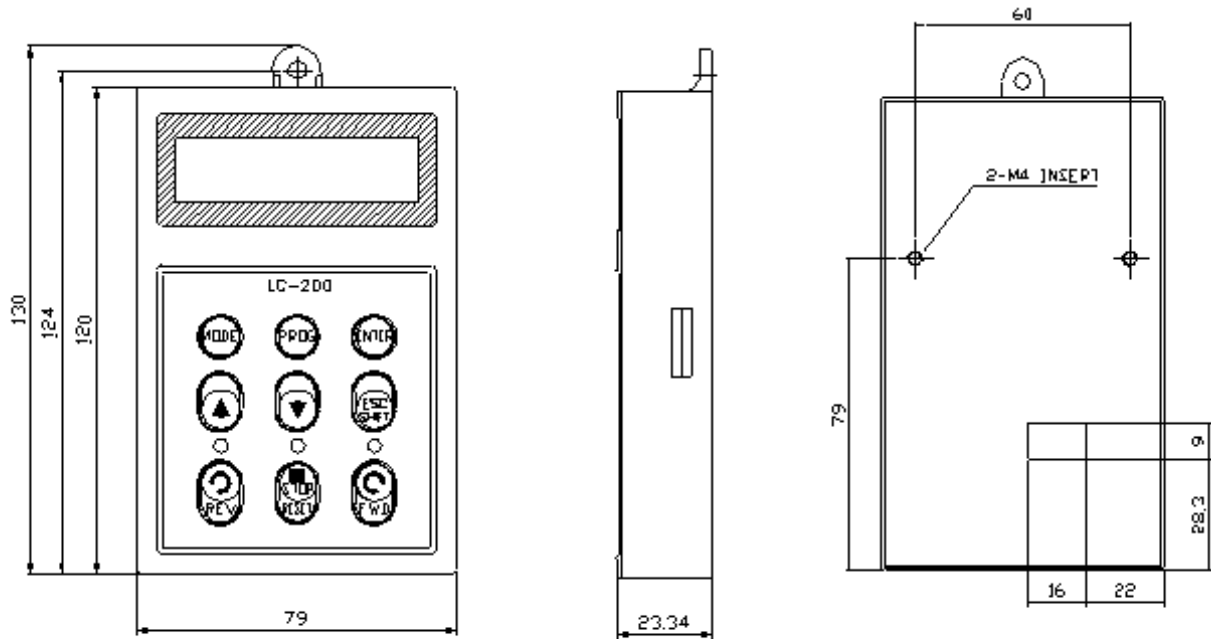

8.2.2 Remote cable

Ordering No.	Description
051050025	Remote cable – 2m
051050026	Remote cable – 3m
051050027	Remote cable – 5m

8.2.3 DB (Dynamic Braking) Unit

Refer to DB Unit option manual for details.

1) DBU Models

UL	Inverter	Applicable motor rating	DB Unit	Dimension
Non UL type	200V class	11 ~ 15 kW (15 ~ 20 HP)	SV150DBU-2	Group 1. See 4) Dimensions
		18.5 ~ 22 Kw (25 ~ 30 HP)	SV220DBU-2	
		30 ~ 37 kW (40 ~ 50 HP)	SV037DBH-2	Group 2. See 4) Dimensions
		45 ~ 55 kW (60 ~ 75 HP)	SV037DBH-2, 2Set	
	400V class	11 ~ 15 kW (15 ~ 20 HP)	SV150DBU-4	Group 1. See 4) Dimensions
		18.5 ~ 22 kW (25 ~ 30 HP)	SV220DBU-4	
		30 ~ 37 kW (40 ~ 50 HP)	SV037DBH-4	Group 2. See 4) Dimensions
		45 ~ 55 kW (60 ~ 75 HP)	SV075DBH-4	
		75 kW (100 HP)		
	UL Type	200V class	11 ~ 15 kW (15 ~ 20 HP)	SV150DBU-2U
18.5 ~ 22 kW (25 ~ 30 HP)			SV220DBU-2 U	
30 ~ 37 kW (40 ~ 50 HP)			SV370DBU-2 U	
45 ~ 55 kW (60 ~ 75 HP)			SV550DBU-2 U	
400V class		11 ~ 15 kW (15 ~ 20 HP)	SV150DBU-4 U	
		18.5 ~ 22 kW (25 ~ 30 HP)	SV220DBU-4 U	
		30 ~ 37 kW (40 ~ 50 HP)	SV370DBU-4 U	
		45 ~ 55 kW (60 ~ 75 HP)	SV550DBU-4 U	
		75 kW (100 HP)	SV750DBU-4 U	
		90~110 kW (125 ~ 150 HP)	SV550DBU-4, 2Set	
		132~160 kW (200 ~ 250 HP)	SV750DBU-4, 2Set	
		220 kW (300 HP)	SV750DBU-4, 3Set	
		280~315 kW (350 ~ 400 HP)	-	
		375~450 kW (500 ~ 600 HP)	-	

2) Terminal Configuration

- Group 1:

CM	OH	G	B2	B1	N	P
----	----	---	----	----	---	---

- Group 2:

G	N	B2	P/B1
---	---	----	------

- Group 3:

P	N	G	B1	B2
---	---	---	----	----

Terminals	Description	Terminals	Description
G	Ground terminal	N	Connect to inverter terminal N
B2	Connect to DB Resistor's B2	P	Connect to inverter terminal P1
B1	Connect to DB Resistor's B1	CM	OH Common
N	Connect to inverter terminal N	OH*	Over Heat Trip output terminal (Open Collector output: 20mA, 27V DC)
P	Connect to inverter terminal P1		

4)Dimensions

- Group 1

(Unit: mm)

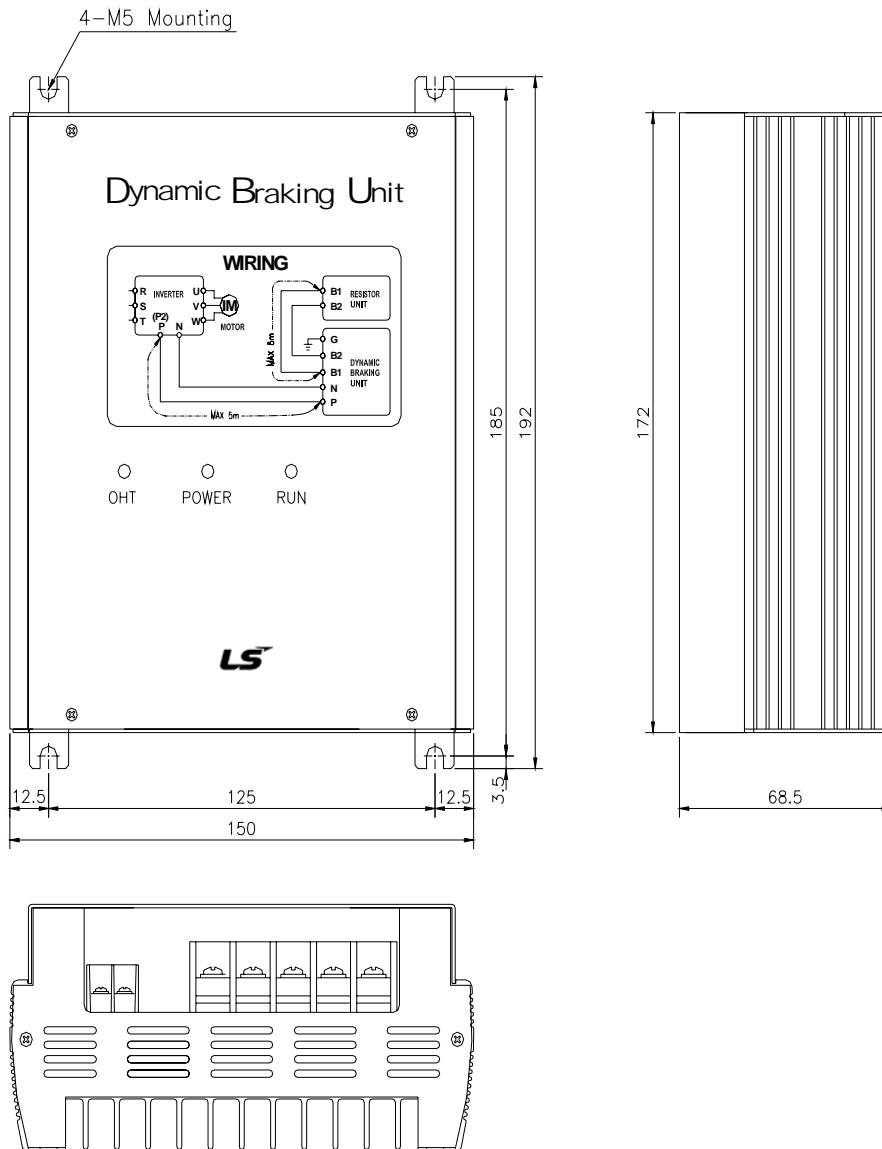

- Group 2

(Unit: mm)

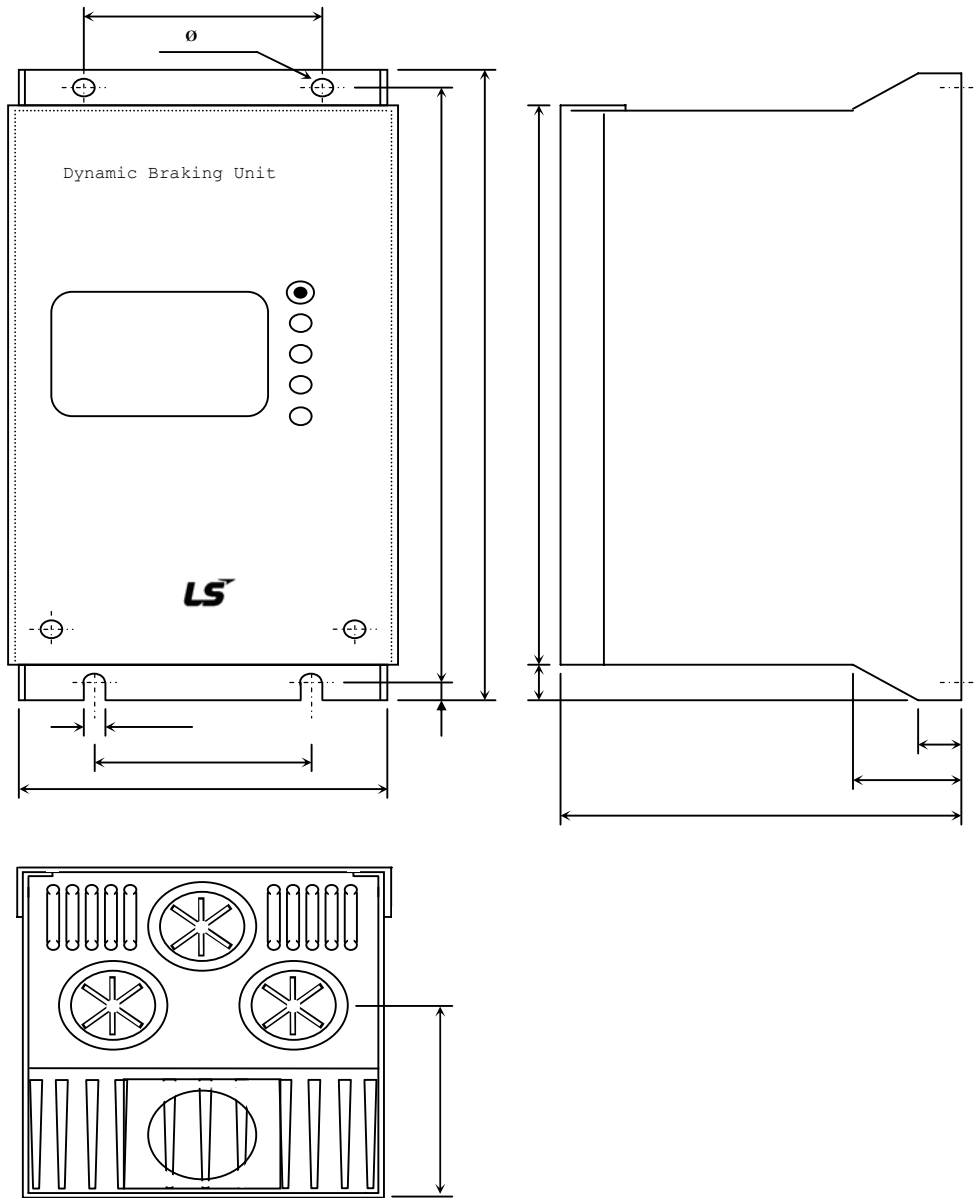

* Group 2

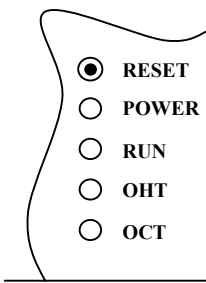

LED	Description
RESET	Press this switch to release OCT FAULT status. Pressing this turns the OCT LED off.
POWER (GREEN)	POWER LED is turned ON upon inverter Power ON because normally it is connected to the inverter.
RUN (GREEN)	RUN LED is blinking while DBU is operating normally by motor regenerating energy.
OHT (RED)	When heat sink is overheated and the level exceeds its setting limit, overheat protection is activated and OHT LED is turned ON after DBU's signal is shut off.
OCT (RED)	Over current trip signal. When overcurrent is flowed to the iGBT, protection function shuts off the operating signal and OCT LED is tured ON.

* Group 3

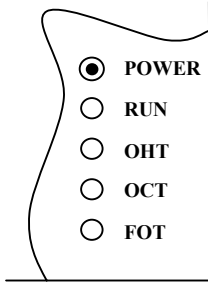

LED	Description
POWER (RED)	POWER LED is turned ON upon inverter Power ON because normally it is connected to the inverter.
RUN (GREEN)	RUN LED is blinking while DBU is operating normally by motor regenerating energy.
OHT (RED)	When heat sink is overheated and the level exceeds its setting limit, overheat protection is activated and OHT LED is turned ON after DBU's signal is shut off.
OCT (RED)	Over current trip signal. When overcurrent is flowed to the iGBT, protection function shuts off the operating signal and OCT LED is tured ON.
FOT (RED)	FOT LED is turned ON when fuse is opened to shut the overcurrent during braking.

8.2.4 DB Resistor

1) External DB Resistor

SV-iP5A inverters do not built-in DB resistor on Power stack as factory installation. External DB Unit and Resistor (Optional) should be installed. See the following table for more details (ED: 5%, Continuous Braking Time: 15 sec). If Enable duty (%ED) is increased to 10%, use the external DB resistor having twice Wattage rating.

	Applied motor capacity (kW / HP)	Operating rate (ED/Continuous Braking Time)	100 % Braking Torque			150% Braking Torque		
			[ohm]	[W]	Type	[ohm]	[W]	Type
200V	5.5 / 7.5	5% / 15 sec	30	700	TYPE 3	20	800	TYPE 3
	7.5 / 10	5% / 15 sec	20	1000	TYPE 3	15	1200	TYPE 3
	11 / 15	5% / 15 sec	15	1400	TYPE 3	10	2400	TYPE 3
	15 / 20	5% / 15 sec	11	2000	TYPE 3	8	2400	TYPE 3
	18.5 / 25	5% / 15 sec	9	2400	TYPE 3	5	3600	TYPE 3
	22 / 30	5% / 15 sec	8	2800	TYPE 3	5	3600	TYPE 3
	30 / 40	10% / 6 sec	4.2	6400	-	-	-	-
400V	5.5 / 7.5	5% / 15 sec	120	700	TYPE 3	85	1000	TYPE 3
	7.5 / 10	5% / 15 sec	90	1000	TYPE 3	60	1200	TYPE 3
	11 / 15	5% / 15 sec	60	1400	TYPE 3	40	2000	TYPE 3
	15 / 20	5% / 15 sec	45	2000	TYPE 3	30	2400	TYPE 3
	18.5 / 25	5% / 15 sec	35	2400	TYPE 3	20	3600	TYPE 3
	22 / 30	5% / 15 sec	30	2800	TYPE 3	20	3600	TYPE 3
	30 / 40	10% / 6 sec	16.9	6400	-	-	-	-
	37 / 50	10% / 6 sec	16.9	6400	-	-	-	-
	45 / 60	10% / 6 sec	11.4	9600	-	-	-	-
	55 / 75	10% / 6 sec	11.4	9600	-	-	-	-
	75 / 100	10% / 6 sec	8.4	12800	-	-	-	-
90 / 125	10% / 6 sec	8.4	12800	-	-	-	-	

2) Dimensions of the DB Resistor

Model	Inverter	Type	Dimension [mm]					
			W	H	D	A	B	C
BR0800W020J	SV 055iP5A-2	3	220	345	93	140	330	7.8
BR1200W015J	SV 075iP5A-2	3	220	345	93	140	330	7.8
BR2400W010J	SV 110iP5A-2	3	220	445	93	140	430	7.8
BR2400W008J	SV 150iP5A-2	3	220	445	93	140	430	7.8
BR3600W005J	SV 185iP5A-2	3	220	445	165	140	430	7.8
BR3600W005J	SV 220iP5A-2	3	220	445	165	140	430	7.8
BR3600W005J	SV 300iP5A-2	3	220	445	165	140	430	7.8
BR1000W085J	SV 055iP5A-4	3	220	345	93	140	330	7.8
BR1200W060J	SV 075iP5A-4	3	220	345	93	140	330	7.8
BR2000W040J	SV 110iP5A-4	3	220	445	93	140	430	7.8
BR2400W030J	SV 150iP5A-4	3	220	445	93	140	430	7.8
BR3600W020J	SV 185iP5A-4	3	220	445	165	140	430	7.8
BR3600W020J	SV 220iP5A-4	3	220	445	165	140	430	7.8

Chapter 8 - Options

* Type 1 (Max 400 Watt)

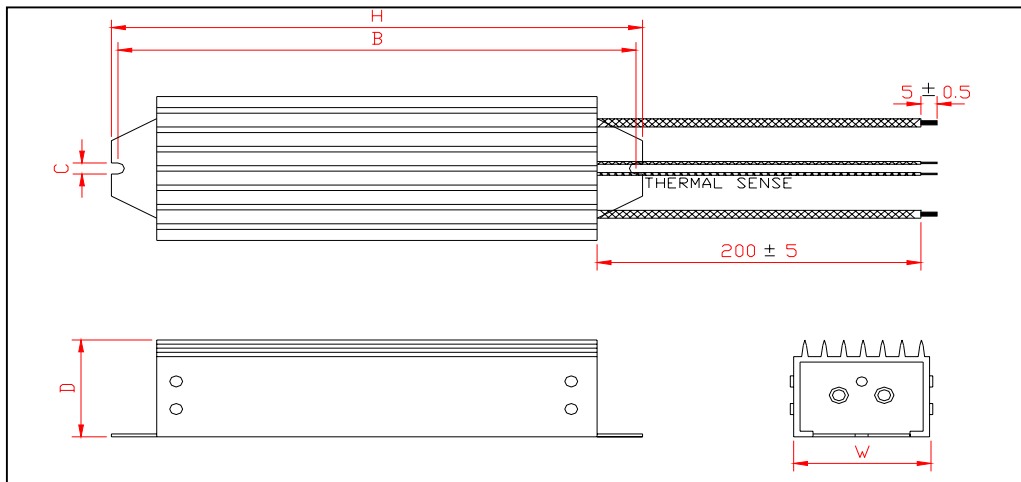

* Type 2 (Max 600 Watt)

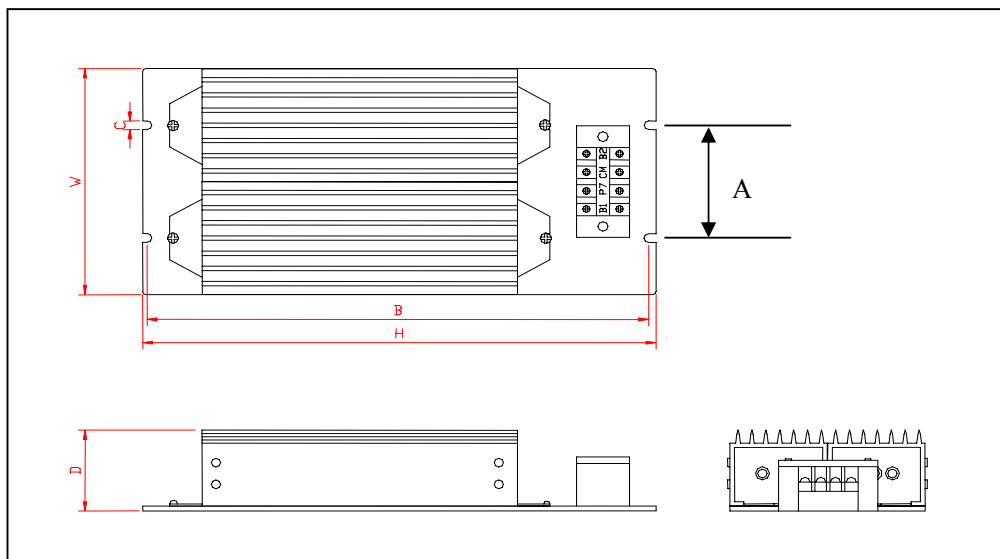

* Type 3

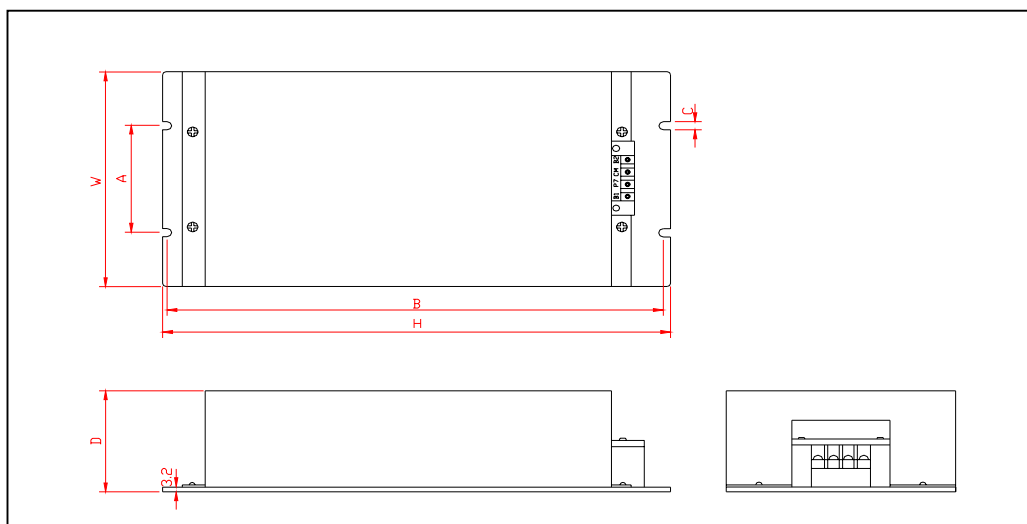

8.2.5 Micro surge filter (Designed for Inverter-driven 400V Class motor)

In the PWM type inverter, a surge voltage attributable to wiring constants is generated at the motor terminals. Especially for a 400V class motor, the surge voltage may deteriorate the insulation. When the 400V class motor is driven by the inverter, consider the following measures:

■ Rectifying the motor insulation

For the 400V class motor, use an insulation-rectified motor. Specifically, the “400V class inverter-driven, insulation-rectified motor”.

For the dedicated motor such as the constant-torque motor and low-vibration motor, use the “inverter-driven, dedicated motor”.

■ Suppressing the surge voltage on the inverter output side

On the secondary side of the inverter, connect the optional surge voltage suppression filter.

■ Wiring

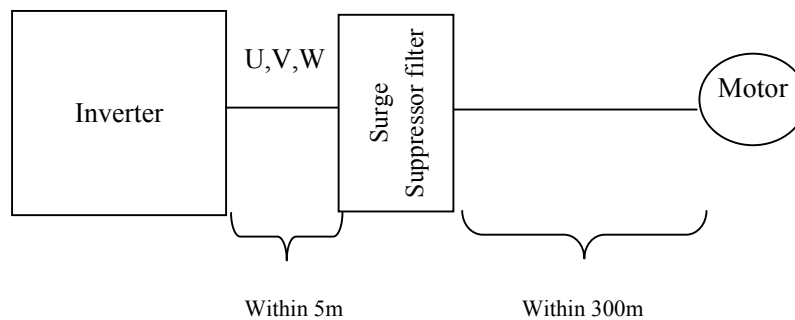

■ Caution

Check the Input/Output when wiring the filter.

Wiring distance from inverter output to filter input should not exceed 5 meter.

Wiring distance from filter to motor should not exceed 300 meter.

8.2.6 NEMA TYPE 1 Optional Conduit Box

1) NEMA TYPE 1 Enclosure for conduit connection

General

NEMA TYPE 1 Conduit Box: This kit enables an inverter to be installed on the wall without the inverter panel and meets NEMA Type 1. It should be installed to meet NEMA 1 for 15~90kW UL Open Type inverters. However, installing this option does not mean UL Type 1. Please purchase Standard UL Type 1 models if needed.

Installation:

Remove the metal plate on the bottom with the driver and install this kit on to the same place by the screws from the metal plate.

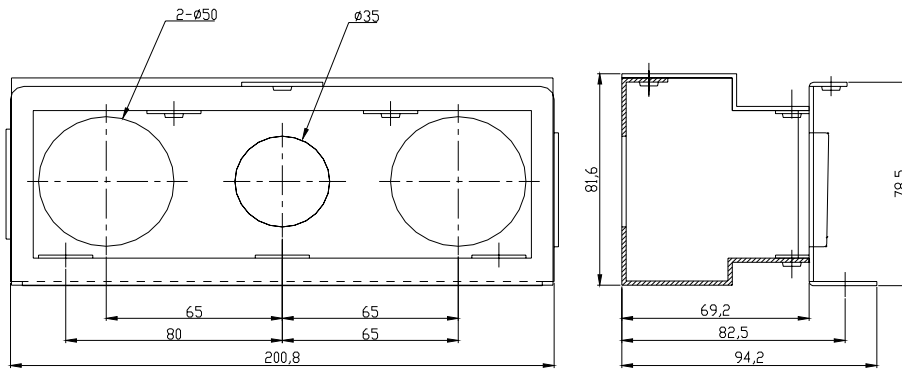

[Conduit box for 150~185iP5A]

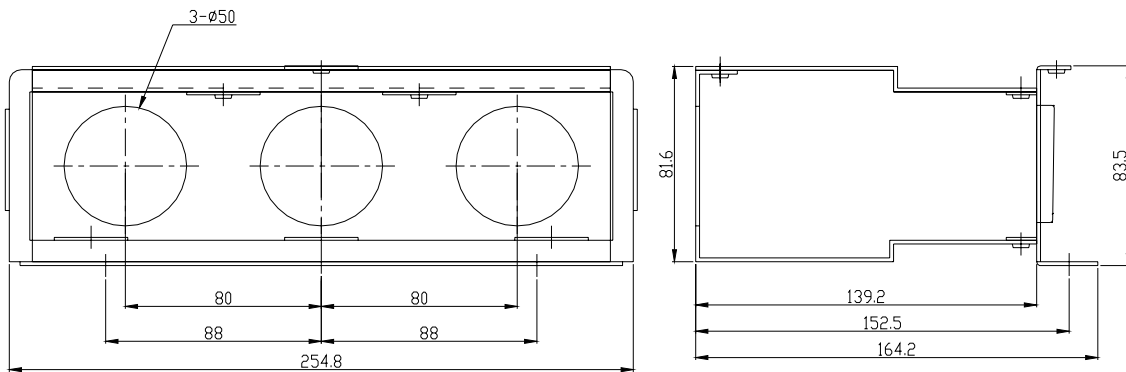

[Conduit box for 220~300iP5A]

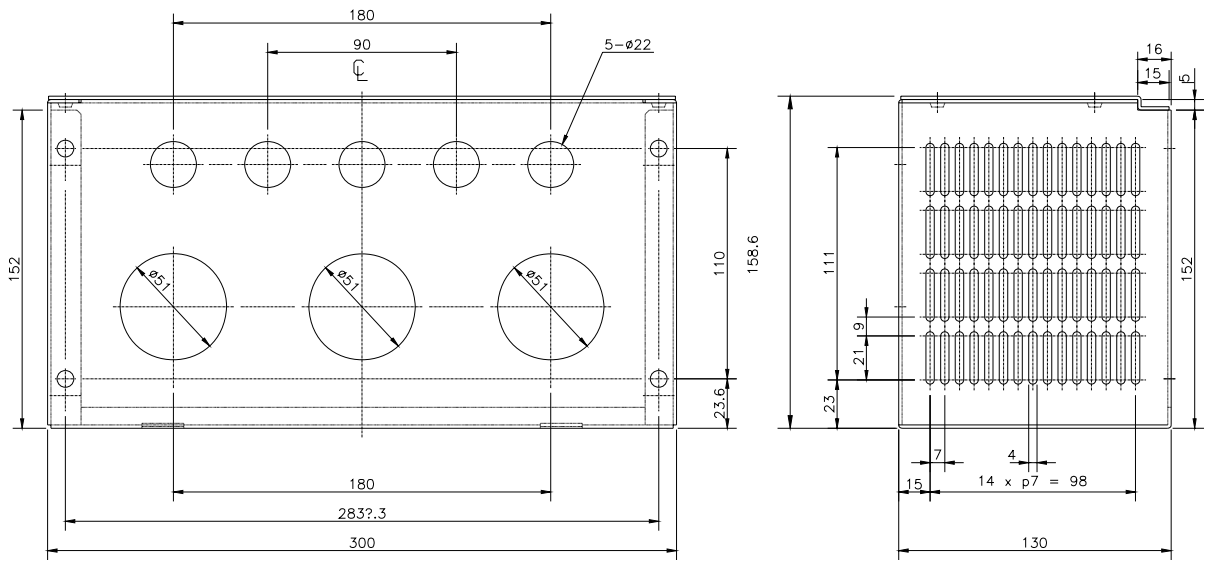

[Conduit box for 370~550iP5A]

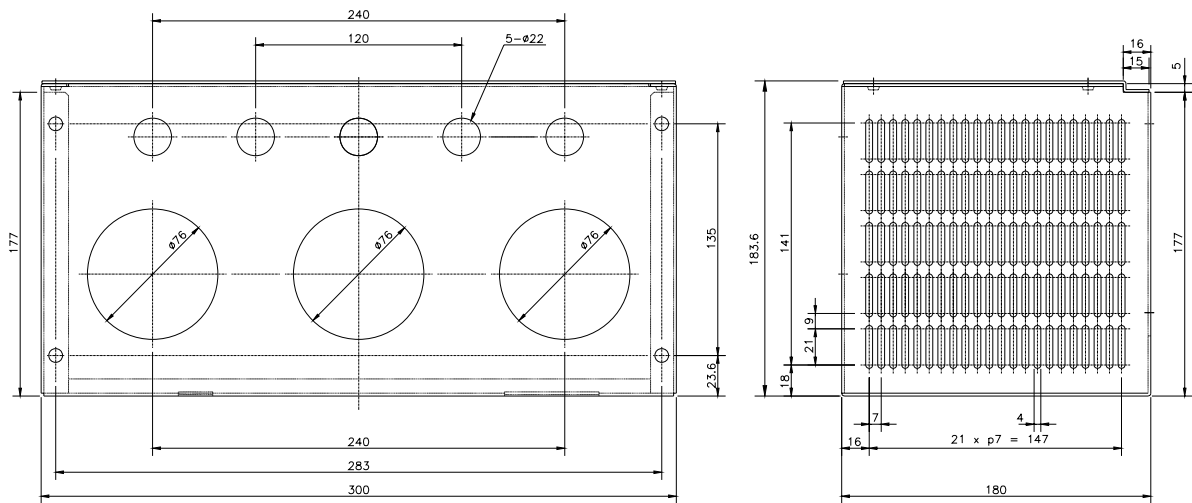

[Conduit box for 750~900iP5A]

Chapter 8 - Options

Conduit Hole Size

mm(inches)

Inverter	Conduit hole for control terminal	Trade Size of the Conduit
	Conduit hole for power terminal	
SV055iP5A-2/4	24 (0.98)	16 (1/2)
	24 (0.98)	16 (1/2)
SV075iP5A-2/4	24 (0.98)	16 (1/2)
	35 (1.37)	27 (1)
SV110iP5A-2/4	24 (0.98)	16 (1/2)
	35 (1.37)	27 (1)
SV150iP5A-2/4	35 (1.37)	27 (1)
	50 (1.96)	41 (3/2)
SV185iP5A-2/4	35 (1.37)	27 (1)
	50 (1.96)	41 (3/2)
SV220iP5A-2/4	50 (1.96)	41 (3/2)
	50 (1.96)	41 (3/2)
SV300iP5A-2/4	50 (1.96)	41 (3/2)
	50 (1.96)	41 (3/2)
SV370iP5A-2/4	22(0.86)	16(1/2)
	51(2.00)	41(3/2)
SV450iP5A-2/4	22(0.86)	16(1/2)
	51(2.00)	41(3/2)
SV550iP5A-2/4	22(0.86)	16(1/2)
	51(2.00)	41(3/2)
SV750iP5A-2/4	22(0.86)	16(1/2)
	76(2.99)	63(5/2)
SV900iP5A-2/4	22(0.86)	16(1/2)
	76(2.99)	63(5/2)

Note: Choose the proper size of the Locknut, Bushing corresponding to trade size of the Conduit in use.

CHAPTER 9 - RS485 COMMUNICATION

9.1 Introduction

Inverter can be controlled and monitored by the sequence program of the PLC or other master module. Drives or other slave devices may be connected in a multi-drop fashion on the RS-485 network and may be monitored or controlled by a single PLC or PC. Parameter setting and change are available through PC.

9.1.1 Features

Inverter can be easily applied for Factory automation because Operation and monitoring is available by User-program.

- * Parameter change and monitoring is available via computer.
(Ex: Accel/Decel time, Freq. Command etc.)
- * Interface type of RS485 reference:
 - 1) Allows the drive to communicate with any other computers.
 - 2) Allows connection of up to 31 drives with multi-drop link system.
 - 3) Noise-resistant interface.

9.1.2 Connection guide for RS485 communication with PC , PLC and RS232/485

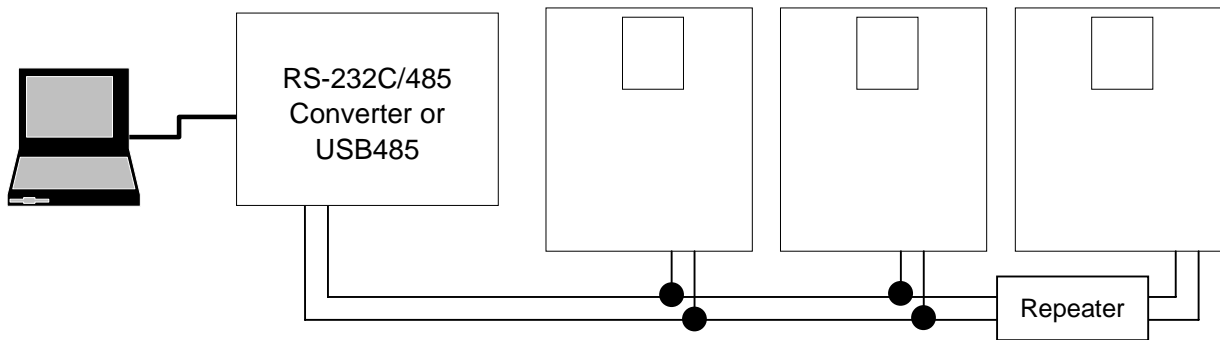

* REPEATER is not a required item but helps communication in long-distance communication or high noise environment.

9.1.3 Before installation

Before installation and operation, this should be read thoroughly. If not, it can cause personal injury or damage to other equipment.

9.2 Specification

9.2.1 Performance specification

Item	Specification
Transmission form	Bus method, Multi-drop Link System
Applicable inverter	SV-iP5A series
Connectable drives	Max 31
Transmission distance	Max. 1,200m (Within 700m Recommended)
Recommended wire	0.75mm ² (12AWG), Shield Type Twisted-Pair Wire

9.2.2 Hardware specification

Item	Specification
Installation	Use C+, C-,CM terminals on control terminal block
Power supply	Use Insulated power from the inverter power supply

9.2.3 Communication specification

Item	Specification
Communication speed	19,200/9,600/4,800/2,400/1,200 bps selectable
Communication system	Half duplex system
Character system	Binary (8 bit)
Stop bit length	1 bit
Error check(CRC16)	2 byte
Parity bit	None
Protocol supported	Parameter Read/Write, Monitoring parameter register/execution Broadcasting

9.2.4 Installation

Connecting the communication line

- 1) Connect the RS485 communication line to the inverter's (C+), (C-) and CM terminals of the control terminals.
- 2) Connect the CM terminal among inverters for stable communication.
- 3) Check the connection and turn ON the inverter.
- 4) If the communication line is connected correctly set the communication-related parameters as the following:
- 5) Install a repeater to upgrade the communication speed or longer than 1200mm communication line is used. Repeater is required for upgrading communication quality in the noise-high environment.

Communication parameters

Code	Display	Name	Set value	Unit	Default
DRV_03	Drive mode	Drive mode	Int. 485		Fx/Rx-1
DRV_04	Freq mode	Freq mode	Int. 485		KeyPad-1
DRV_91	Drive mode2	Drive mode 2	KeyPad Fx/Rx-1 Fx/Rx-2		Fx/Rx-1
DRV_92	Freq mode2	Freq mode 2	KeyPad-1 KeyPad-2 V1 V1S I V1+I Pulse		KeyPad-1
I/O_20~27	M1 ~ M8	Programmable Digital Inputs	Main-drive		
I/O_90	Inv No	Inverter number	1~250		1
I/O_91	Baud rate	Communication speed	1200 bps 2400 bps 4800 bps 9600 bps 19200 bps		9600 bps
I/O_92	COM Lost Cmd	Operating mode when communication signal is lost	None FreeRun Stop		None
I/O_93	COM Time Out	Time to determine whether Communication signal is lost.	0.1~120.0	sec	1.0

9.3 Operation

9.3.1 Operating steps

- 1) Check whether the computer and the inverter are connected correctly.
- 2) Turn ON the inverter. But, do not connect the load until stable communication between the computer and the inverter is verified. Start the operating program for the inverter from the computer.
- 3) Operate the inverter using the operating program for the inverter.
- 4) Refer to “13.8 Troubleshooting” if the communication is not operating normally.
- 5) User program or the “DriveView” program supplied from LS Industrial Systems can be used as the operating program for the inverter.
- 6) Turn the inverter J3 switch ON to connect the terminating resistor for the end of network.

* Connect to C+,C-,CM terminal on the control terminal. Be careful for the polarity(+, -).

* Max connectable inverter is 31.

9.4 Communication protocol (RS485)

The configuration of RS485 is that PC or PLC is the Master and Inverter Slave.

Inverter responds the Master’s Read/Write Requests.

When master sends Write Request to Inverter address # 255, all inverters perform Write action but do not return a Acknowledge response. This is used to drive multiple inverters at the same time via RS485.

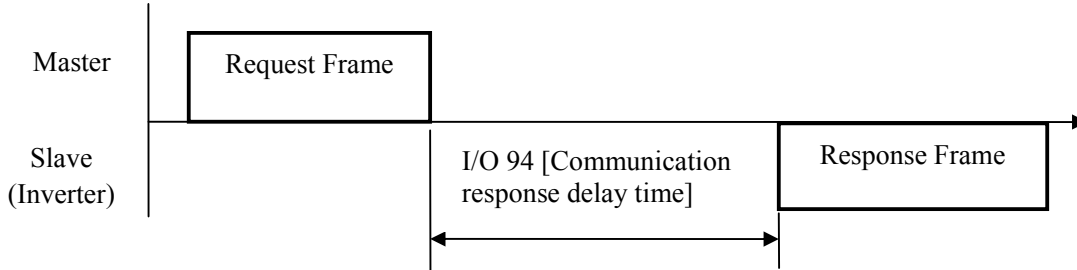

9.4.1 Basic format

1) Command message (Request):

ENQ	Inverter No.	CMD	Data	SUM	EOT
1 byte	2 bytes	1 byte	n bytes	2 bytes	1 byte

* Normal response (Acknowledge Response):

ENQ	Inverter No.	CMD	Data	SUM	EOT
1 byte	2 bytes	1 byte	n * 4 bytes	2 bytes	1 byte

* Negative response (Negative Acknowledge Response):

ENQ	Inverter No.	CMD	Data	SUM	EOT
1 byte	2 bytes	1 byte	2 bytes	2 bytes	1 byte

2) Description:

- * Request starts with “ENQ” and ends with “EOT”.
- * Acknowledge Response starts with “ACK” and ends with “EOT”.
- * Negative Acknowledge Response starts with ”NAK” and ends with “EOT”.
- * “Inverter Number” is the number of Inverters used and indicated in 2 byte ASCII-HEX. (ASCII-HEX: Hexadecimal consists of ‘0’ ~ ‘9’, ‘A’ ~ ‘F’)

* CMD: Capital letter (“IF Error” when small letter is used.)

Character	ASCII-HEX	Command
‘R’	52h	Read
‘W’	57h	Write
‘X’	58h	Request for monitoring
‘Y’	59h	Action for monitoring

- Data: ASCII-HEX
Ex) when data value is 3000: 3000 (dec) ‘0’ ’B’ ’B’ ’8’h 30h 42h 42h 38h
- Error code: ASCII (20h ~ 7Fh)
- Receive/Send buffer size: Receive= 39 byte, Send=44 byte
- Monitor register buffer: 8 Word
- SUM: to check the communication error

SUM= ASCII-HEX format of lower 8 bit of (Inverter No. + CMD + DATA)

Ex) Command Message (Request) for reading one address from address “9000”

ENQ	Inverter No.	CMD	Address	Number of address to read	SUM	EOT
05h	“01”	“R”	“9000”	“1”	“AD”	04h
1 byte	2 bytes	1 byte	4 bytes	1 byte	2 bytes	1 byte

$$\begin{aligned} \text{SUM} &= '0' + '1' + 'R' + '9' + '0' + '0' + '0' + '1' \\ &= 30h + 31h + 52h + 39h + 30h + 30h + 30h + 31h \\ &= 1ADh \end{aligned}$$

9.4.2 Detail communication protocol

1) Request for Read: Request for read successive ‘N’ numbers of WORD from address “XXXX”

ENQ	Inv No	CMD	Address	Number of Address	SUM	EOT
05h	“01” ~ “FA”	“R”	“XXXX”	“1” ~ “8” = n	“XX”	04h
1 byte	2 byte	1 byte	4 byte	1 byte	2 byte	1 byte

Total byte = 12

The quotation marks (“ ”) mean character.

1.1) Acknowledge Response:

ACK	Inv No	CMD	Data	SUM	EOT
06h	“01” ~ “FA”	“R”	“XXXX”	“XX”	04h
1 byte	2 byte	1 byte	N * 4 byte	2 byte	1 byte

Total byte = 7 * n * 4 = Max. 39

1.2) Negative Acknowledge Response:

NAK	Inv No	CMD	Error code	SUM	EOT
15h	“01” ~ “FA”	“R”	“**”	“XX”	04h
1 byte	2 byte	1 byte	2 byte	2 byte	1 byte

Total byte = 9

2) Request for Write:

ENQ	Inverter No	CMD	Address	Number of Address	SUM	EOT	EOT
05h	“01” ~ “FA”	“W”	“XXXX”	“1” ~ “8” = n	“XXXX...”,	“XX”	04h
1	2	1	4	1	n * 4	2	1

Total byte = 12 + n * 4 = Max. 44

2.1) Acknowledge response:

ACK	Inverter No.	CMD	Data	SUM	EOT
06h	“01” ~ “FA”	“W”	“XXXX...”	“XX”	04h
1 byte	2 byte	1 byte	n * 4 byte	2 byte	1 byte

Total byte = 7 + n * 4 = Max. 39

Note) When Request for Write and Acknowledge Response is exchanged between PC and Inverter for the first time, previous data is returned. From the second time of transmission, the current data will be received.

2.2) Negative response:

NAK	Inverter No.	CMD	Error code	SUM	EOT
15h	“01” ~ “FA”	“W”	“***”	“XX”	04h
1 byte	2 byte	1 byte	2 byte	2 byte	1 byte

Total byte = 9

3) Request for Monitor Register: This is useful when constant parameter monitoring and data updates are required.

Request for Register of ‘n’ numbers of Address (non-successive)

ENQ	Inverter No.	CMD	Number of Address	Address	SUM	EOT
05h	“01” ~ “FA”	“X”	“1” ~ “8”=n	“XXXX...”	“XX”	04h
1 byte	2 byte	1 byte	1 byte	n * 4 byte	2 byte	1 byte

Total byte = 8 + n * 4 = Max 40

3.1) Acknowledge Response:

ACK	Inverter No.	CMD	SUM	EOT
06h	“01” ~ “FA”	“X”	“XX”	04h
1 byte	2 byte	1 byte	2 byte	1 byte

Total byte = 7

3.2) Negative Acknowledge Response:

NAK	Inverter No.	CMD	Error code	SUM	EOT
15h	“01” ~ “FA”	“X”	“***”	“XX”	04h
1 byte	2 byte	1 byte	2 byte	2 byte	1 byte

Total byte = 9

4) Action Request for monitor register: Request for read of address registered by monitor register.

ENQ	Inverter No.	CMD	SUM	EOT
05h	“01” ~ “FA”	“Y”	“XX”	04h
1 byte	2 byte	1 byte	2 byte	1 byte

Total byte = 7

4.1) Acknowledge response:

ACK	Inverter No.	CMD	Data	SUM	EOT
06h	“01” ~ “FA”	“Y”	“XXXX...”	“XX”	04h
1 byte	2 byte	1 byte	n * 4 byte	2 byte	1 byte

Total byte = 7 + n * 4 = Max 39

4.2) Negative response:

NAK	Inverter No.	CMD	Error code	SUM	EOT
15h	“01” ~ “FA”	“Y”	“***”	“XX”	04h
1 byte	2 byte	1 byte	2 byte	2 byte	1 byte

Total byte = 9

* Request for Monitor Register should be made before Action Request for monitor register. If inverter power is turned off, monitor register is cleared so redo the request for monitor register when Power ON.

5) Error code

Error code	Description
IF	ILLEGAL FUNCTION When master is sending codes other than Function code (R, W, X, Y).
IA	ILLEGAL ADDRESS - When parameter address does not exist
ID	ILLEGAL VALUE - When Data contains an out of range value for an inverter parameter during 'W' (Write).
WM	WRITE MODE ERROR - When the requested data cannot be changed (written) during 'W' (Write) such as Read Only, Not adjustable during Run parameters.

9.5 Parameter code list

<Common area>: Area accessible regardless of inverter models (Note 3)

Address	Parameter	Unit	Unit	R/W	Data value
0x0000	Inverter model			R	9 : SV-iP5A
0x0001	Inverter capacity			R	4: 5.5kW(7.5HP), 5: 7.5kW(10HP), 6: 11kW(15HP), 7: 15kW(20HP), 8: 18.5kW(25HP), 9: 22kW(30HP), A: 30kW(40HP), B: 37kW(50HP), C: 45kW(60HP), D: 55kW(75HP), E: 75kW(100HP) F: 90kW(125HP) 10: 110kW(150HP) 11: 132kW(200HP) 12: 160kW(250HP) 13: 220kW(300HP) 14: 280kW(350HP) 15: 315kW(400HP) 16: 375kW(500HP) 17: 450kW(600HP)
0x0002	Inverter Input Voltage			R	0 : 220V Class 1 : 400V Class
0x0003	S/W Version			R	(Ex) 0x0100 : Version 1.00 0x0101 : Version 1.10
0x0005	Frequency Reference	0.01	Hz	R/W	
0x0006	Run Command (Note 1)			R/W	BIT 0: Stop (S) BIT 1: Forward run (F) BIT 2: Reverse run (R) BIT 3: Fault reset (0->1) BIT 4: Emergency stop BIT 5: Not used
				R	BIT 6, BIT 7: Run/Stop command source 0(Terminal), 1(Keypad), 2(Option) 3: Int. 485 BIT 8 ~12: Freq. reference 0 ~ 16: Multi-step speed freq. (0, 2~16) 17 ~ 19: UpDown (Up, Down, UD Zero) 20 ~ 21: RESERVED 22 ~ 25: Analog (V1, V1S, I, V1I) 26: Pulse 27: Sub 28: Int. 485 29: Option, 30: Jog, 31 : PID BIT 15: set when Network error
0x0007	Acceleration Time	0.1	sec	R/W	
0x0008	Deceleration Time	0.1	sec	R/W	
0x0009	Output Current	0.1	A	R	
0x000A	Output Frequency	0.01	Hz	R	
0x000B	Output Voltage	0.1	V	R	
0x000C	DC Link voltage	0.1	V	R	
0x000D	Output power	0.1	kW	R	
0x000E	Operating status of Inverter			R	BIT 0: Stop BIT 1: Forward running BIT 2: Reverse running BIT 3: Fault (Trip) BIT 4: Accelerating BIT 5: Decelerating

Address	Parameter	Unit	Unit	R/W	Data value
					BIT 6: speed arrival
0x000E	Operating status of Inverter			R	BIT 7: DC Braking BIT 8: Stopping Bit 9: not Used BIT10: Brake Open BIT11: Forward run command BIT12: Reverse run command BIT13: REM. R/S (Int. 485, OPT) BIT14: REM. Freq. (Int. 485, OPT)
0x000F	Trip information			R	BIT 0 : OCT1 BIT 1 : OV BIT 2 : EXT-A BIT 3 : BX BIT 4 : LV BIT 5 : RESERVE BIT 6 : GF(Ground Fault) BIT 6: OHT (Inverter overheat) BIT 7: ETH (Motor overheat) BIT 8: OLT (Overload trip) BIT10: HW-Diag BIT11: RESERVE BIT12: OCT2 BIT13: OPT (Option error) BIT14 : PO (Phase Open) BIT15: IOLT
0x0010	Input terminal status			R	BIT 0 : M1 BIT 1 : M2 BIT 2 : M3 BIT 3 : M4 BIT 4 : M5 BIT 5 : M6 BIT 6 : M7 BIT 7 : M8 BIT 8 : - BIT 9 : - BIT 10 : -
0x0011	Output terminal status			R	BIT 0 : AUX1 BIT 1 : AUX2 BIT 2 : AUX3 BIT 3 : AUX4 BIT 4 : - BIT 5 : - BIT 6 : - BIT 7 : 30AC
0x0012	V1	0~10V		R	
0x0013	V2	0~10V		R	
0x0014	I	0~20mA		R	

Chapter 9 – RS485 Communication

Address	Parameter	Unit	Unit	R/W	Data value
0x0015	RPM			R	
0x001A	Unit display			R	0 : Hz, 1 : Rpm
0x001B	Pole number			R	
0x001C	Custom Version			R	

Note 1) Detail description on Common area address 0x0006

Bit	Value	R/W	Name	Description
0	0x01	R/W	Stop	Issue a Stop command via communication (0->1)
1	0x02	R/W	Forward run	Issue a Forward run command via communication (0->1)
2	0x04	R/W	Reverse run	Issue a Reverse run command via communication (0->1)
3	0x08	R/W	Fault reset	Issue a Fault reset command via communication (0->1)
4	0x10	R/W	Emergency stop	Issue a Emergency stop command via communication (0->1)
5			Not used	Not Used
6~7		R	Operating command	0(Terminal),1(keypad),2(option),3(Int. 485)
8~14		R	Frequency command	A. When operating command is issued via Terminal, Keypad or Option 0: DRV-00, 1: Not used, 2 : Multi-step speed 1, 3 : Multi-step speed 2, 4 : Multi-step speed 3 5 : Multi-step speed 4, 6 : Multi-step speed 5, 7 : Multi-step speed 6 8 : Multi-step speed 7, 9 : Multi-step speed 8, 10 : Multi-step speed 9 11: Multi-step speed 10, 12: Multi-step speed 11, 13: Multi-step speed 12 14: Multi-step speed 13, 15 : Multi-step speed 14 , 16 : Multi-step speed 15, 17 :Up, 18 : Down, 19: Up/Down Zero 20~21 : RESERVE 22 : V1, 23 : V1S, 24 : I, 25 : V1+I 26 : Pulse 27 : Sub 28 : Int. 485 29 : Option 30 : Jog 31 : PID
15	0x8000	R	Network error	Network malfunction

9.5.1 iP5A operating status in Address E, Common area

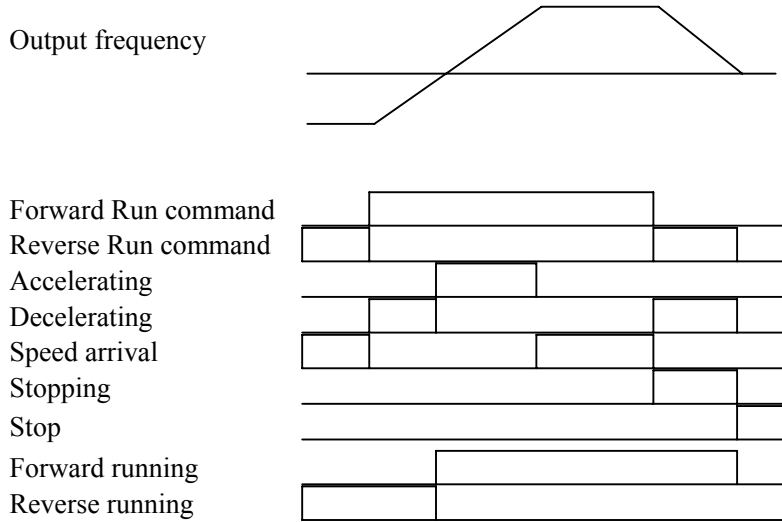

< Address usage area by groups >

DRV	9100 - 91FF
FU1	9200 - 92FF
FU2	9300 - 93FF
I/O	9400 - 94FF
EXT	9500 - 95FF
COM	9600 - 96FF
APP	9700 - 97FF

Address setting method to access the parameter using RS485: area assigned by inverter+ Address usage area by groups + Code no. (Hex).

Ex) To check the content of I/O-93 [COM Time Out], perform Read or Write the address 0x945D.

9.6 Troubleshooting

Refer to the below chart when RS485 communication error occurs.

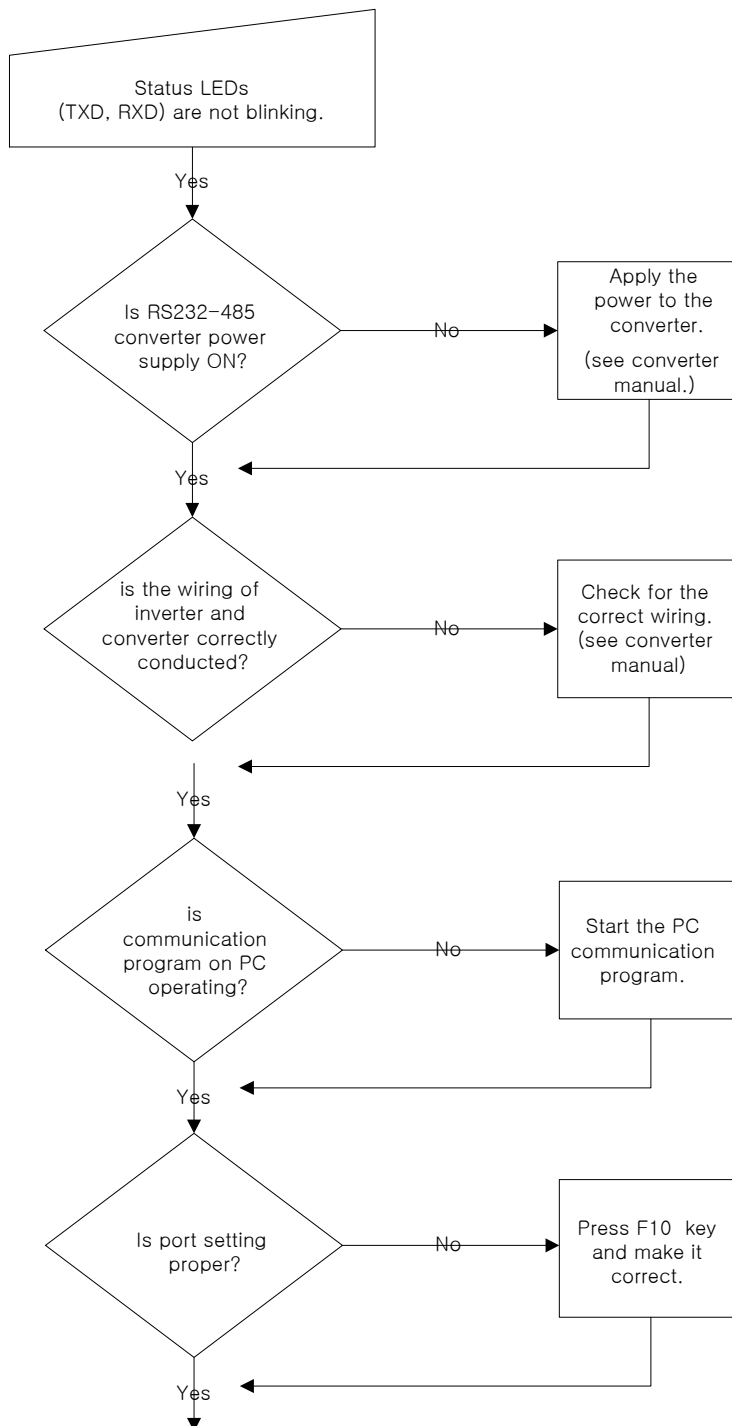

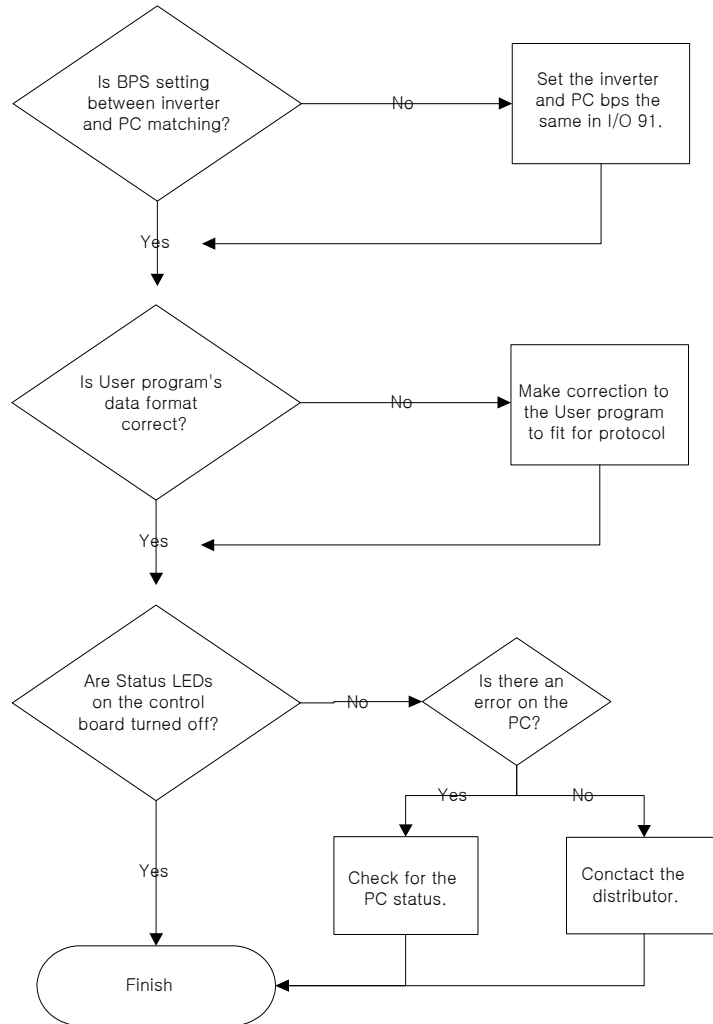

9.7 ASCII Code List

Character	Hex	Character	Hex	Character	Hex
A	41	q	71	@	40
B	42	r	72	[5B
C	43	s	73	\	5C
D	44	t	74]	5D
E	45	u	75		5E
F	46	v	76		5F
G	47	w	77		60
H	48	x	78	{	7B
I	49	y	79		7C
J	4A	z	7A	}	7D
K	4B	0	30	~	7E
L	4C	1	31	BEL	07
M	4D	2	32	BS	08
N	4E	3	33	CAN	18
O	4F	4	34	CR	0D
P	50	5	35	DC1	11
Q	51	6	36	DC2	12
R	52	7	37	DC3	13
S	53	8	38	DC4	14
T	54	9	39	DEL	7F
U	55	space	20	DLE	10
V	56	!	21	EM	19
W	57	"	22	ACK	06
X	58	#	23	ENQ	05
Y	59	\$	24	EOT	04
Z	5A	%	25	ESC	1B
A	61	&	26	ETB	17
B	62	'	27	ETX	03
C	63	(28	FF	0C
D	64)	29	FS	1C
E	65	*	2A	GS	1D
F	66	+	2B	HT	09
G	67	,	2C	LF	0A
H	68	-	2D	NAK	15
I	69	.	2E	NUL	00
J	6A	/	2F	RS	1E
K	6B	:	3A	S1	0F
L	6C	;	3B	SO	0E
M	6D	<	3C	SOH	01
N	6E	=	3D	STX	02
O	6F	>	3E	SUB	1A
P	70	?	3F	SYN	16
				US	1F
				VT	0B

APPENDIX A- UL MARKING

1. SHORT CIRCUIT RATING

“Suitable For Use On A Circuit Capable Of Delivering Not More Than Table1_RMS Symmetrical Amperes, 240V for 240V rated inverters, 480V for 480V rated inverters Volts Maximum,”

Table 1. RMS Symmetrical Amperes for iP5A series.

Model	Rating
SV055iP5A-2, SV055iP5A-4, SV075iP5A-2, SV075iP5A-4, SV110iP5A-2, SV110iP5A-4, SV150iP5A-2, SV150iP5A-4, SV185iP5A-2, SV185iP5A-4, SV220iP5A-2, SV220iP5A-4, SV300iP5A-2, SV300iP5A-4, SV370iP5A-4, SV450iP5A-4, SV550iP5A-4, SV750iP5A-4, SV900iP5A-4, SV1100iP5A-4, SV1320iP5A-4, SV1600iP5A-4, SV2200iP5A-4, SV2800iP5A-4, SV3150iP5A-4, SV3750iP5A-4, SV4500iP5A-4	100,000A

2. SHORT CIRCUIT FUSE/BREAKER

Use Class H or K5 UL Listed Input Fuse and UL Listed Breaker Only. See the table below for the Voltage and Current rating of the fuses and the breakers.

Input Voltage	Motor [kW]	Inverter	External Fuse		Breaker		Internal Fuse				
			Current [A]	Voltage [V]	Current [A]	Voltage [V]	Current [A]	Voltage [V]	Manufacturer	Model Number	
200V Class	5.5	SV055iP5A-2	40	500	50	230					
	7.5	SV075iP5A-2	60	500	60	230					
	11	SV110iP5A-2	80	500	100	230					
	15	SV150iP5A-2	100	500	100	230					
	18.5	SV185iP5A-2	125	500	225	230					
	22	SV220iP5A-2	150	500	225	230					
	30	SV300iP5A-2	200	500	225	230					
400V Class	5.5	SV055iPS5-4	20	500	30	460					
	7.5	SV075iP5A-4	30	500	30	460					
	11	SV110iPS5-4	40	500	50	460					
	15	SV150iP5A-4	60	500	60	460					
	18.5	SV185iP5A-4	70	500	75	460					
	22	SV0220iP5A-4	80	500	100	460					
	30	SV0300iP5A-4	100	500	125	460					
	37	SV0370iP5A-4	125	500	125	460	160	660	Hinode	660GH-160SUL	
	45	SV0450iP5A-4	150	500	150	460	160	660	Hinode	660GH-160SUL	
	55	SV0550iP5A-4	175	500	175	460	200	660	Hinode	660GH-200SUL	
	75	SV0750iP5A-4	250	500	225	460	250	660	Hinode	660GH-250SUL	
	90	SV0900iP5A-4	300	500	300	460	315	660	Hinode	660GH-315SUL	
	110	SV01100iP5A-4	350	700	400	460	200	2P	660	Hinode	660GH-200SUL 2P
	132	SV01320iP5A-4	400	700	500	460	250	2P	660	Hinode	660GH-250SUL 2P
	160	SV01600iP5A-4	450	700	600	460	315	2P	660	Hinode	660GH-315SUL 2P
	220	SV02200iP5A-4	700	700	800	460	250	3P	660	Hinode	660GH-250SUL 3P
	280	SV02800iP5A-4	800	700	1000	460	315	3P	660	Hinode	660GH-315SUL 3P
315	SV03150iP5A-4	900	700	1000	460	800	690	Ferraz	6.9URD32TTF0800		
375	SV03750iP5A-4	1000	700	1200	460	900	690	Ferraz	6.9URD32TTF0900		
450	SV04500iP5A-4	1200	700	1200	460	1000	690	Ferraz	6.9URD32TTF1000		

3. OVER LOAD PROTECTION

IOLT: IOLT(inverter Overload Trip) protection is activated at 110% of the inverter rated current for 1 minute and greater.

OLT : Inverter shuts off its output when inverter output current exceeds its overload trip level for overload trip time. OLT is selected when FU1-66 is set to “Yes” and activated at 120% of FU1-67 [Motor rated current] for 60 sec set in FU1-68.

4. OVER SPEED PROTECTION

Not Provided With Overspeed Protection.

5. FIELD WIRING TERMINAL

- 1) Use copper wires only with 600V, 75 ratings
- 2) Tightening torque of power terminal blocks

Inverter Capacity [kW]	Terminal Screw Size	Screw Torque ¹		Wire ²				
		Kgf-cm	lb-in	mm		AWG or kcmil		
				R,S,T	U,V,W	R,S,T	U,V,W	
200V Class	5.5	M4	7.1 ~ 12.2	6.2~10.6	5.5	5.5	10	10
	7.5	M5			8	8	8	8
	11	M5	24.5 ~ 31.8	21.2~27.6	14	14	6	6
	15	M6			22	22	4	4
	18.5	M6	30.6 ~ 38.2	26.6~33.2	38	38	2	2
	22	M8			38	38	2	2
30	M8	61.2 ~ 91.8	53.1~79.7	60	60	1/0	1/0	
400V Class	5.5	M4	7.1 ~ 12.2	6.2~10.6	3.5	3.5	12	12
	7.5	M4			3.5	3.5	12	12
	11	M4			5.5	5.5	10	10
	15	M6	30.6~38.2	26.6~33.2	8	8	8	8
	18.5	M6			14	14	6	6
	22	M8	61.2~91.8	53.1~79.7	22	22	4	4
	30	M8			22	22	4	4
	37	M8			38	38	2	2
	45	M8	67.3~87.5	58.4~75.9	38	38	2	2
	55	M8			38	38	2	2
	75	M10	89.7~122.0	77.9~105.9	60	60	1/0	1/0
	90	M10			60	60	1/0	1/0
	110	M12	182.4~215.0	158.3~186.6	100	100	4/0	4/0
	132	M12			100	100	4/0	4/0
	160	M12			150	150	300	300
	220	M12			200	200	400	400
	280	M12	182.4~215.0	158.3~186.6	250	250	500	500
	315	M12			325	325	700	700
375	M12	2 200			2 200	2 400	2 400	
450	M12	2 250			2 250	2 500	2 500	

¹ Apply the rated torque to terminal screws. Loose screws can cause of short circuit or malfunction. Tightening the screws too much can damage the terminals and cause a short circuit or malfunction.

- 3) For 7.5~11kW 240V type inverters, Input and motor output terminal blocks are intended only for use with ring type connectors.

6. BASIC WIRING

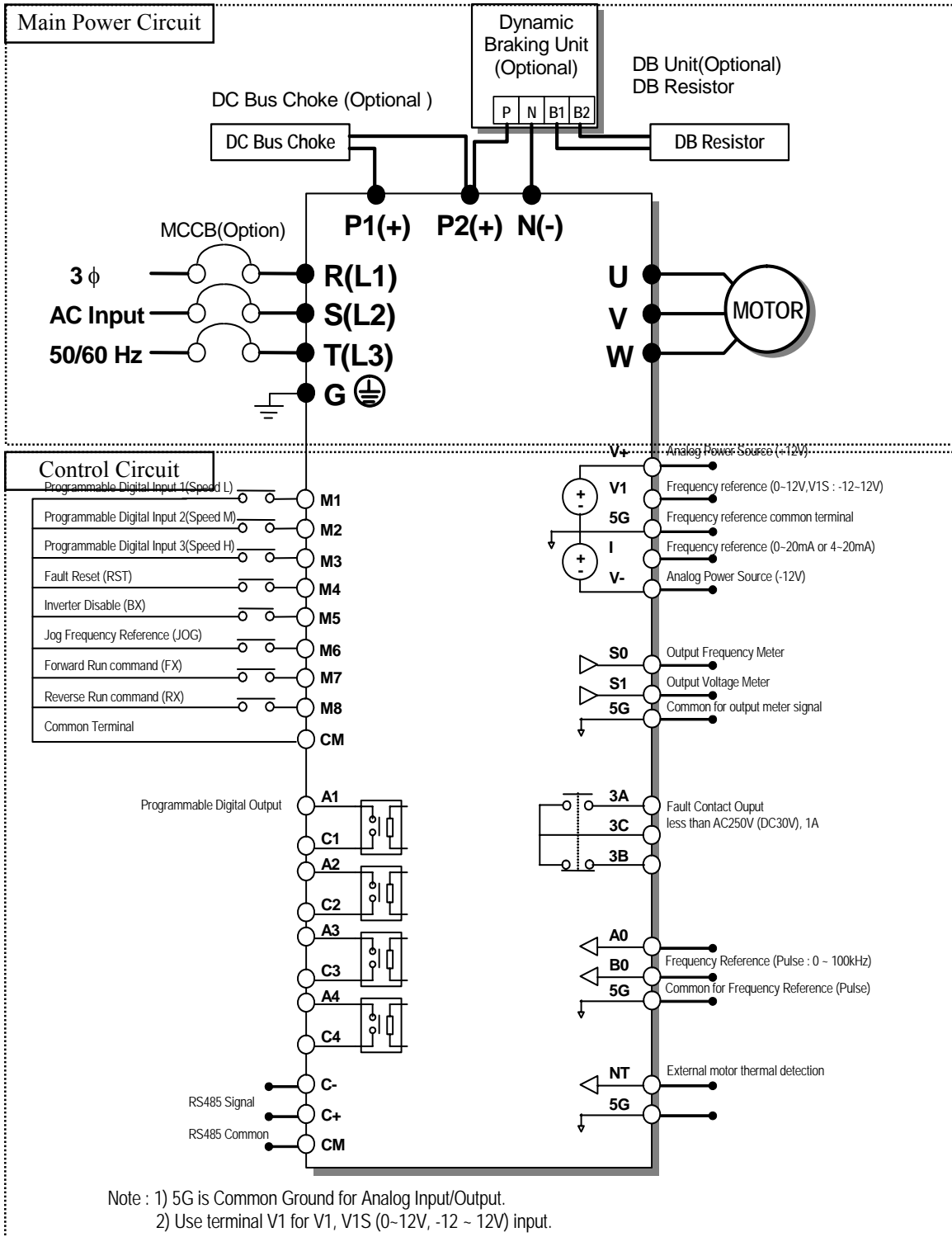

⚠ CAUTION

Risk of Electric Shock

More than one disconnect switch may be required to de-energize the equipment before servicing.

APPENDIX B- PERIPHERAL DEVICES

1. MCCB (Molded Case Circuit Breaker) and MC (Magnetic Contactor)

Voltage	Motor [kW]	Inverter Model	MCCB (LS Industrial Systems)	MC (LS Industrial Systems)
200V Class	5.5	SV055iP5A-2	ABS53b/50A	GMC-40
	7.5	SV075iP5A-2	ABS63b/60A	GMC-40
	11	SV110iP5A-2	ABS103b/100A	GMC-50
	15	SV150iP5A-2	ABS103b/100A	GMC-85
	18.5	SV185iP5A-2	ABS203b/125A	GMC-100
	22	SV220iP5A-2	ABS203b/150A	GMC-100
	30	SV300iP5A-2	ABS203b/175A	GMC-150
400V Class	5.5	SV055iP5A-4	ABS33b/30A	GMC-22
	7.5	SV075iP5A-4	ABS33b/30A	GMC-22
	11	SV110iP5A-4	ABS53b/50A	GMC-40
	15	SV150iP5A-4	ABS63b/60A	GMC-50
	18.5	SV185iP5A-4	ABS63b/60A	GMC-50
	22	SV220iP5A-4	ABS103b/100A	GMC-65
	30	SV300iP5A-4	ABS103b/100A	GMC-75
	37	SV370iP5A-4	ABS203b/125A	GMC-100
	45	SV450iP5A-4	ABS203b/150A	GMC-125
	55	SV550iP5A-4	ABS203b/175A	GMC-150
	75	SV750iP5A-4	ABS203b/225A	GMC-180
	90	SV900iP5A-4	ABS403b/300A	GMC-220
	110	SV1100iP5A-4	ABS403b/400A	GMC-300
	132	SV1300iP5A-4	ABS603b/500A	GMC-300
	160	SV1600iP5A-4	ABS603b/600A	GMC-400
	220	SV2200iP5A-4	ABS803b/700A	GMC-600
	280	SV2800iP5A-4	ABS803b/800A	GMC-600
	315	SV3150iP5A-4	ABS1003/1000A	GMC-800
375	SV3750iP5A-4	ABS1203/1200A	900A	
450	SV4500iP5A-4	ABS1203/1200A	1000A	

2. AC Input Fuse and AC / DC Reactor

Voltage	Motor [kW]	Inverter Model	AC Input Fuse [A]	AC Reactor		DC Reactor	
				[mH]	[A]	[mH]	[A]
200V Class	5.5	SV055iP5A-2	40	0.39	30	1.37	29
	7.5	SV075iP5A-2	60	0.28	40	1.05	38
	11	SV110iP5A-2	80	0.20	59	0.74	56
	15	SV150iP5A-2	100	0.15	75	0.57	71
	18.5	SV185iP5A-2	125	0.12	96	0.49	91
	22	SV220iP5A-2	150	0.10	112	0.42	107
	30	SV300iP5A-2	200	0.07	160	0.34	152
400V Class	5.5	SV055iP5A-4	20	1.22	15	5.34	14
	7.5	SV075iP5A-4	30	1.14	20	4.04	19
	11	SV110iP5A-4	40	0.81	30	2.76	29
	15	SV150iP5A-4	60	0.61	38	2.18	36
	18.5	SV185iP5A-4	70	0.45	50	1.79	48
	22	SV220iP5A-4	80	0.39	58	1.54	55
	30	SV300iP5A-4	100	0.287	80	1.191	76
	37	SV370iP5A-4	125	0.232	98	0.975	93
	45	SV450iP5A-4	150	0.195	118	0.886	112
	55	SV550iP5A-4	175	0.157	142	0.753	135
	75	SV750iP5A-4	250	0.122	196	0.436	187
	90	SV900iP5A-4	300	0.096	237	0.352	225
	110	SV1100iP5A-4	350	0.081	289	Built-in	
	132	SV1300iP5A-4	400	0.069	341	Built-in	
	160	SV1600iP5A-4	450	0.057	420	Built-in	
	220	SV2200iP5A-4	700	0.042	558	Built-in	
	280	SV2800iP5A-4	800	0.029	799	Built-in	
	315	SV3150iP5A-4	900	0.029	799	0.090	836
375	SV3750iP5A-4	1000	0.024	952	0.076	996	
450	SV4500iP5A-4	1200	0.024	952	0.064	1195	

APPENDIX C- RELATED PARAMETERS

Use	Related parameter codes
Accel/Decel time, Pattern Adjustment	DRV-01 [Acceleration Time], DRV-02 [Deceleration Time], FU1-02 [Acceleration Pattern], FU1-03 [Deceleration Pattern]
Reverse Rotation Prevention	FU1-01 [Forward/Reverse Prevention]
Accel/Decel at Continuous Rating Range	FU1-02 [Acceleration Pattern], FU1-03 [Deceleration Pattern]
Braking Operation Adjustment	FU1-20 [Starting Mode], FU1-21~22 [DC Injection Braking at Starting] FU1-23 [Stop Mode], FU1-24~27 [DC Injection Braking],
Operations at freq. Over 60 Hz	FU1-30 [Max. Frequency], FU1-35 [Frequency High Limit], I/O-05 [Frequency Corresponding to V1 Max Voltage], I/O-10 [Frequency Corresponding to I Max Current], I/O-16 [Frequency Corresponding to I Max Pulse]
Selecting an Appropriate Output Characteristics for the Load	FU1-30 [Max. Frequency], FU1-31 [Base Frequency]
Motor Output Torque Adjustment	FU1-32 [Starting Frequency], FU1-70~71 [Stall Prevention], FU2-67~69 [Torque Boost], FU2-40 [Motor Rating]
Output Frequency Limit	FU1-33~35 [Frequency High/Low Limit], I/O-01~16 [Analog Frequency Setting]
Motor Overheat Protection	FU1-60~62 [Electronic Thermal], FU2-40 [Motor Rating] I/O-97, 98 [External Thermal Sensor]
Multi-step Operation	I/O-20~27 [Programmable Digital Input Define], DRV-00, 05~07, I/O-31~42 [Multi-step Frequency], FU1-34~35 [Frequency High/Low Limit]
Jog Operation	I/O-30 [Jog Frequency]
Frequency Jump Operation	FU2-10~16 [Frequency Jump]
Electronic Brake Operation Timing	I/O-74~75 [Frequency Detection], I/O-76~79 [Programmable Digital Output Define]
Rotating Speed Display	DRV-09 [Motor Rpm], FU2-47 [Motor Rpm Display Gain]
Function Change Prevention	FU2-94 [Parameter Lock]
Energy Saving	FU1-51~52 [Energy Saving]
Auto Restart Operation after Alarm Stop	FU2-20~21 [Auto Restart]
2 nd Motor Operation	APP-20~29 [2 nd Function]
PID Feedback Operation	APP-02~17 [PID Operation]
Adjusting Frequency Reference/Output	I/O-01~16 [Analog Frequency Setting]
Commercial Line<-> Inverter Switchover	I/O-20~27 [Programmable Digital Input Terminal], I/O-76~79 [Programmable Digital Output Terminal]
Frequency Meter Calibration	I/O-70~73 [S0/S1 Analog Output]
Operation via Communication with a PC	I/O-90 [Inverter Number], I/O-91 [Communication Speed], I/O-92~93 [Lost Command]

DECLARATION OF CONFORMITY

Council Directive(s) to which conformity is declared:

CD 73/23/EEC and CD 89/336/EEC

Units are certified for compliance with:

EN 61800-3/A11 (2000)
EN 61000-4-2/A2 (2001)
EN 61000-4-3/A2 (2001)
EN 61000-4-4/A2 (2001)
EN 61000-4-5/A1 (2001)
EN 61000-4-6/A1 (2001)
EN 55011/A2 (2002)
IEC/TR 61000-2-1 (1990)
EN 61000-2-4 (2002)
EN 60146-1-1/A1 (1997)
EN 50178 (1997)

Type of Equipment:	Inverter (Power Conversion Equipment)
Model Name:	SV - iP5A Series
Trade Mark:	LS Industrial Systems Co., Ltd.
Representative: Address:	LG International (Deutschland) GmbH Lyoner Strasse 15, Frankfurt am Main, 60528, Germany
Manufacturer: Address:	LS Industrial Systems Co., Ltd. 181, Samsung-ri, Mokchon-Eup, Chonan, Chungnam, 330-845, Korea

We, the undersigned, hereby declare that equipment specified above conforms to the Directives and Standards mentioned.

Place: **Frankfurt am Main**
Germany

Chonan, Chungnam,
Korea

 20/02/01
(Signature / Date)

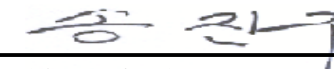
 2005/04/26
(Signature/Date)

Mr. Ik-Seong Yang / Dept. Manager
(Full name / Position)

Mr. Jin Goo Song / General Manager
(Full name / Position)

TECHNICAL STANDARDS APPLIED

The standards applied in order to comply with the essential requirements of the Directives 73/23/CEE "Electrical material intended to be used with certain limits of voltage" and 89/336/CEE "Electromagnetic Compatibility" are the following ones:

-
- **EN 50178 (1997)** "Electronic equipment for use in power installations".

 - **EN 61800-3/A11 (2000)** "Adjustable speed electrical power drive systems. Part 3: EMC product standard including specific methods"
 - **EN 55011/A2 (2002)** "Industrial, scientific and medical (ISM) radio-frequency equipment. Radio disturbances characteristics. Limits and methods of measurement"
 - **EN 61000-4-2/A2 (2001)** "Electromagnetic compatibility (EMC). Part 4: Testing and measurement techniques. Section 2: Electrostatic discharge immunity test.
 - **EN 61000-4-3/A2 (2001)** "Electromagnetic compatibility (EMC). Part 4: Testing and measurement techniques. Section 3: Radiated, radiofrequency, electromagnetic field immunity test.
 - **EN 61000-4-4/A2 (2001)** "Electromagnetic compatibility (EMC). Part 4: Testing and measurement techniques. Section 4: Electrical fast transients / burst immunity test.
 - **EN 61000-4-5/A1 (2000)** "Electromagnetic compatibility (EMC). Part 4: Testing and measurement techniques. Section 5: Surge immunity test.
 - **EN 61000-4-6/A1 (2001)** "Electromagnetic compatibility (EMC). Part 4: Testing and measurement techniques. Section 6: Immunity to conducted disturbances, induced by radio-frequency fields.
 - **CEI/TR 61000-2-1 (1990)** "Electromagnetic compatibility (EMC). Part 2: Environment. Environment description for low-frequency conducted disturbances and signalling in public low voltages supply systems"
 - **EN 61000-2-4 (1997)** "Electromagnetic compatibility (EMC). Part 2: Environment. Compatibility level in industrial plants for low-frequency conducted disturbances"
 - **EN 60146-1-1/A1 (1997)** "Semiconductor convertors. General requirements and line commutated convertors. Part 1-1: Specifications of basic requirements"

EMI / RFI POWER LINE FILTERS

LS inverters, iP5A series



RFI FILTERS

THE L.S. RANGE OF POWER LINE FILTERS FF (Footprint) - FE (Standard) SERIES, HAVE BEEN SPECIFICALLY DESIGNED WITH HIGH FREQUENCY LS INVERTERS. THE USE OF L.S. FILTERS, WITH THE INSTALLATION ADVICE OVERLEAF HELP TO ENSURE TROUBLE FREE USE ALONG SIDE SENSITIVE DEVICES AND COMPLIANCE TO CONDUCTED EMISSION AND IMMUNITY STANDARDS TO EN 50081 -> EN61000-6-3:02 and EN61000-6-1:02

CAUTION

IN CASE OF A LEAKAGE CURRENT PROTECTIVE DEVICES IS USED ON POWER SUPPLY, IT MAY BE FAULT AT POWER-ON OR OFF. IN AVOID THIS CASE, THE SENSE CURRENT OF PROTECTIVE DEVICE SHOULD BE LARGER THAN VALUE OF LAKAGE CURRENT AT WORST CASE IN THE BELOW TABLE.

RECOMMENDED INSTALLATION INSTRUCTIONS

To conform to the EMC directive, it is necessary that these instructions be followed as closely as possible. Follow the usual safety procedures when working with electrical equipment. All electrical connections to the filter, inverter and motor must be made by a qualified electrical technician.

- 1-) Check the filter rating label to ensure that the current, voltage rating and part number are correct.
- 2-) For best results the filter should be fitted as closely as possible to the incoming mains supply of the wiring enclosure, usually directly after the enclosures circuit breaker or supply switch.
- 3-) The back panel of the wiring cabinet of board should be prepared for the mounting dimensions of the filter. Care should be taken to remove any paint etc... from the mounting holes and face area of the panel to ensure the best possible earthing of the filter.
- 4-) Mount the filter securely.
- 5-) Connect the mains supply to the filter terminals marked LINE, connect any earth cables to the earth stud provided. Connect the filter terminals marked LOAD to the mains input of the inverter using short lengths of appropriate gauge cable.
- 6-) Connect the motor and fit the ferrite core (output chokes) as close to the inverter as possible. Armoured or screened cable should be used with the 3 phase conductors only threaded twice through the center of the ferrite core. The earth conductor should be securely earthed at both inverter and motor ends. The screen should be connected to the enclosure body via and earthed cable gland.
- 7-) Connect any control cables as instructed in the inverter instructions manual.

IT IS IMPORTANT THAT ALL LEAD LENGTHS ARE KEPT AS SHORT AS POSSIBLE AND THAT INCOMING MAINS AND OUTGOING MOTOR CABLES ARE KEPT WELL SEPARATED.

FF SERIES (Footprint)

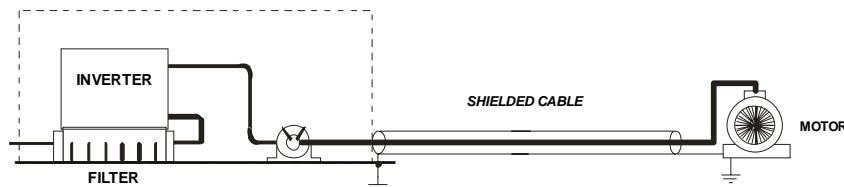

FE SERIES (Standard)

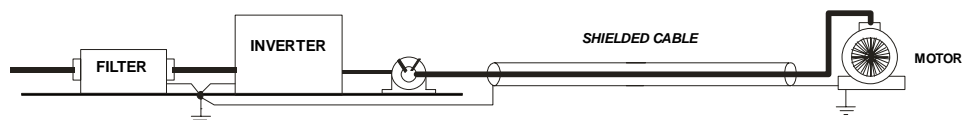

ip5A series / Footprint Filters										
INVERTER	POWER	CODE	CURRENT	VOLTAGE	LEAKAGE CURRENT	DIMENSIONS L W H	MOUNTING Y X	WEIGHT	MOUNT	OUTPUT CHOKES
THREE PHASE					NOM. MAX.					
SV055iP5A-2	5.5kW	FFP5-T030-(x)	30A	250VAC	0.3mA 18mA	329x149.5x50	315x120	2 Kg.	M5	FS – 2
SV075iP5A-2	7.5kW	FFP5-T050-(x)	50A	250VAC	0.3mA 18mA	329x199.5x60	315x160	2.5 Kg.	M5	FS – 2
SV110iP5A-2	11kW		100A	250VAC	0.3mA 18mA					FS – 3
SV150iP5A-2	15kW									
SV185iP5A-2	18kW		120A	250VAC	0.3mA 18mA					FS – 3
SV220iP5A-2	22kW									
SV300iP5A-2	30kW		150A	250VAC	0.3mA 18mA					FS – 3
SV055iP5A-4	5.5kW	FFP5-T030-(x)	30A	380VAC	0.5mA 27mA	329x149.5x50	315x120	2 Kg.	M5	FS – 2
SV075iP5A-4	7.5kW	FFP5-T031-(x)	31A	380VAC	0.5mA 27mA	329x199.5x60	315x160	2.5 Kg.	M5	FS – 2
SV110iP5A-4	11kW	FFP5-T050-(x)	50A	380VAC	0.5mA 27mA	329x199.5x60	315x160	2.5 Kg.	M5	FS – 2
SV150iP5A-4	15kW	FFP5-T060-(x)	60A	380VAC	0.5mA 27mA	466x258x65	440.5x181	2.8 Kg.	M5	FS – 2
SV185iP5A-4	18kW									
SV220iP5A-4	22kW	FFP5-T070-(x)	70A	380VAC	0.5mA 27mA	541x312x65	515.5x235.3	6.1 Kg.	M8	FS – 2
SV300iP5A-4	30kW									

ip5A series / Standard Filters										
INVERTER	POWER	CODE	CURRENT	VOLTAGE	LEAKAGE CURRENT	DIMENSIONS L W H	MOUNTING Y X	WEIGHT	MOUNT	OUTPUT CHOKES
THREE PHASE					NOM. MAX.					
SV055iP5A-2	5.5kW	FE-T030-(x)	30A	250VAC	0.3mA 18mA	270x140x60	258x106	2.4 Kg.	---	FS – 2
SV075iP5A-2	7.5kW	FE-T050-(x)	50A	250VAC	0.3mA 18mA	270x140x90	258x106	3.2 Kg.	---	FS – 2
SV110iP5A-2	11kW	FE-T100-(x)	100A	250VAC	0.3mA 18mA	420x200x130	408x166	13.8 Kg.	---	FS – 3
SV150iP5A-2	15kW									
SV185iP5A-2	18kW	FE-T120-(x)	120A	250VAC	0.3mA 18mA	420x200x130	408x166	13.8 Kg.	---	FS – 3
SV220iP5A-2	22kW									
SV300iP5A-2	30kW	FE-T150-(x)	150A	250VAC	0.3mA 18mA	490x200x160	468x166	15 Kg.	---	FS – 3
SV055iP5A-4	5.5kW	FE-T030-(x)	30A	380VAC	0.5mA 27mA	270x140x60	258x106	2.4 Kg.	---	FS – 2
SV075iP5A-4	7.5kW									
SV110iP5A-4	11kW	FE-T050-(x)	50A	380VAC	0.5mA 27mA	270x140x90	258x106	3.2 Kg.	---	FS – 2
SV150iP5A-4	15kW									
SV185iP5A-4	18kW	FE-T060-(x)	60A	380VAC	0.5mA 27mA	270x140x90	258x106	3.5 Kg.	---	FS – 2
SV220iP5A-4	22kW	FE-T070-(x)	70A	380VAC	0.5mA 27mA	350x180x90	338x146	7.5 Kg.	---	FS – 3
SV300iP5A-4	30kW									
SV370iP5A-4	37kW	FE-T100-(x)	100A	380VAC	1.3mA 150mA	425x200x130	408x166	13.8 Kg.	---	FS – 3
SV450iP5A-4	45kW	FE-T120-(x)	120A	380VAC	1.3mA 150mA	425x200x130	408x166	13.8 Kg.	---	FS – 3
SV550iP5A-4	55kW									
SV750iP5A-4	75kW	FE-T170-(x)	170A	380VAC	1.3mA 150mA	480x200x160	468x166	16 Kg.	---	FS – 3
SV900iP5A-4	90kW	FE-T230-(x)	230A	380VAC	1.3mA 150mA	580x250x205	560x170	22.6 Kg.	---	FS – 4
SV1100iP5A-4	110kW	FE-T400-(x)	400A	380VAC	1.3mA 150mA	392x260x116	240x235	10.3 Kg.	---	FS – 4
SV1320iP5A-4	132kW									
SV1600iP5A-4	160kW	FE-T600-(x)	600A	380VAC	1.3mA 150mA	392x260x116	240x235	11 Kg.	---	FS – 4
SV2200iP5A-4	220kW									
SV2800iP5A-4	280kW	FE-T1000-(x)	1000A	380VAC	1.3mA 150mA	460x280x166	290x255	18 Kg.	---	FS – 4
SV3150iP5A-4	315kW									
SV3750iP5A-4	375kW									
SV4500iP5A-4	450kW	FE-T1600-(x)	1600A	380VAC	1.3mA 150mA	592x300x166	340x275	27 Kg.	---	FS – 4

(x) (1) Industrial environment EN50081-2 (A class) -> EN61000-6-4:02

(3) Domestic and industrial environment EN50081-1 (B class) -> EN61000-6-3:02

FS SERIES (output chokes)

CODE	D	W	H	X	Ø
FS 2	28.5	105	62	90	5
FS 3	48	150	110	125 x 30	5
FS 4	58	200	170	180 x 45	5

DIMENSIONS

FF SERIES (Footprint)

FFP5-T030-(x) ~ FFP5-T070-(x)

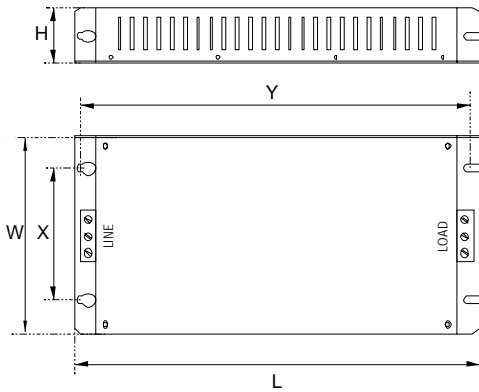

FE SERIES (Standard)

FE-T030-(x) ~ FE-T230-(x)

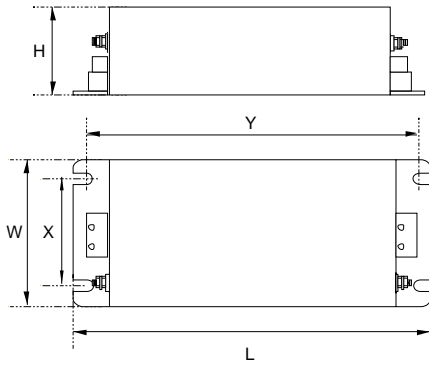

FE-T400-(x) ~ FE-T1600-(x)

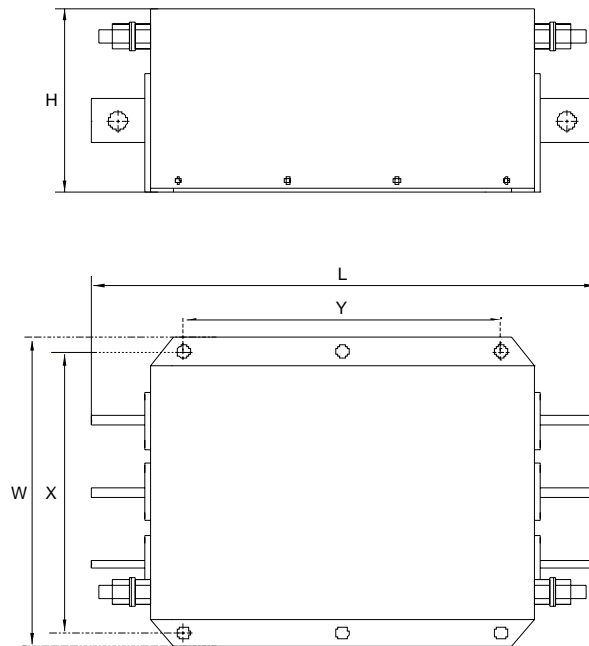

Warranty

Maker	LS Industrial Systems Co., Ltd.		Installation (Start-up) Date	
Model No.	SV-iP5A		Warranty Period	
Customer Information	Name			
	Address			
	Tel.			
Sales Office (Distributor)	Name			
	Address			
	Tel.			

Warranty period is 12 months after installation or 18 months after manufactured when the installation date is unidentified. However, the guarantee term may vary on the sales term.

■ IN-WARRANTY service information

If the defective part has been identified under normal and proper use within the guarantee term, contact your local authorized LS distributor or LS Service center.

■ OUT-OF WARRANTY service information

The guarantee will not apply in the following cases, even if the guarantee term has not expired.

- Damage was caused by misuse, negligence or accident.
- Damage was caused by abnormal voltage and peripheral devices' malfunction (failure).
- Damage was caused by improper repair or altering by other than LS authorized distributor or service center.
- Damage was caused by an earthquake, fire, flooding, lightning, or other natural calamities.
- When LS nameplate is not attached.
- When the warranty period has expired.

Revision History

No.	Date	Edition	Changes
1	October, 2004	First Release	-
2	June, 2005	2 nd Edition	CI changed
3	June, 2006	3 rd Edition	Revised for new kW(HP) ratings
4	November, 2006	4 th Edition	S/W Version up (V0.4)
5	December, 2006	5 th Edition	Contents added and revised
6	November, 2008	6 th Edition	Contents added and revised



LS values every single customer.
Quality and service come first at LSIS.
Always at your service, standing for our customers.

www.lsis.biz

LS Industrial Systems

10310000487

■ **HEAD OFFICE**

Yonseil Jaedan Severance Bldg, 84-11 5 ga, Namdaemun-ro,
 Jung-gu Seoul 100-753, Korea <http://eng.lsis.biz>
 Tel. (82-2)2034-4643~4649 Fax.(82-2)2034-4879, 2034-4885

■ **LS Industrial Systems Tokyo Office >> Japan**

Address: 16F, Higashi-Kan, Akasaka Twin Towers 17- 22,
 2-chome, Akasaka, Minato-ku, Tokyo 107-8470, Japan
 Tel: 81-3-3582-9128 Fax: 81-3-3582-2667

e-mail: jschuna@lsis.biz

■ **LS Industrial Systems Dubai Rep. Office >> UAE**

Address: P.O.BOX-114216, API World Tower, 303B, Sheikh
 Zayed road, Dubai, UAE. e-mail: hwym@lsis.biz
 Tel: 971-4-3328289 Fax: 971-4-3329444

■ **LS-VINA Industrial Systems Co., Ltd. >> Vietnam**

Address: LSIS VINA Congty che tao may dien Viet-Hung
 Dong Anh Hanoi, Vietnam e-mail: srjo@hn.vnn.vn
 Tel: 84-4-882-0222 Fax: 84-4-882-0220

■ **LS Industrial Systems Hanoi Office >> Vietnam**

Address: Room C21, 5th Floor, Horison Hotel, 40 Cat Linh,
 Hanoi, Vietnam
 Tel: 84-4-736-6270/1 Fax: 84-4-736-6269

■ **Dalian LS Industrial Systems co., Ltd. >> China**

Address: No. 15 Liaohexi 3 Road, economic and technical
 development zone, Dalian, China e-mail: lixk@lgs.com.cn
 Tel: 86-411-8273-7777 Fax: 86-411-8730-7560

■ **LS Industrial Systems (Shanghai) Co., Ltd. >> China**

Address: Room E-G, 12th Floor Huamin Empire Plaza,
 No. 726, West Yan'an Road, Shanghai, China
 Tel: 86-21-5237-9977

■ **LS Industrial Systems(Wuxi) Co., Ltd. >> China**

Address: 102-A National High & New Tech Industrial
 Development Area, Wuxi, Jiangsu, China e-mail: Xugh@lgs.com.cn
 Tel: 86-510-534-6666 Fax: 86-510-522-4078

■ **LS Industrial Systems Beijing Office >> China**

Address: B-tower 17th Floor, Beijing Global Trade Center building,
 No. 36, BeiSanHuanDong-Lu, DongCheng-District, Beijing, China
 Tel: 86-10-5825-6025

■ **LS Industrial Systems Guangzhou Office >> China**

Address: Room 1403, 14F, New Poly Tower, 2 Zhongshan Liu
 Rad, Guangzhou, China e-mail: zhangch@lgs.com.cn
 Tel: 86-20-8326-6754 Fax: 86-20-8326-6287

■ **LS Industrial Systems Chengdu Office >> China**

Address: Room 2907, Zhong Yin B/D, No. 35, Renminzhong(2)-
 Road, Chengdu, China e-mail: hongkonk@vip.163.com
 Tel: 86-28-8612-9151 Fax: 86-28-8612-9236

■ **LS Industrial Systems Qingdao Office >> China**

Address: 12th Floor, Guodong building, No52 Jindun Road,
 Chengdu, China e-mail: bellkuk@hanmail.net
 Tel: 86-532-580-2539 Fax: 86-532-583-3793

※ LS Industrial Systems constantly endeavors to improve its product so that
 Information in this manual is subject to change without notice.

SV-IP5A/2008.11