

EPower[™] Controller User Guide

EPower[™] Power management and control units
Versions 3.06 and later

HA179769 Issue 11
December 2015



Restriction of Hazardous Substances (RoHS)

Product group: EPower, EPowerMC

Table listing restricted substances

Chinese

限制使用材料一览表						
产品	有毒有害物质或元素					
	铅	汞	镉	六价铬	多溴联苯	多溴二苯醚
EPower						
驱动器	X	0	X	0	0	0
功率模块 50安培	X	X	0	0	0	0
功率模块 100安培	X	X	0	0	0	0
功率模块 160安培	X	X	0	0	0	0
功率模块 250安培	X	X	0	0	0	0
功率模块 400安培	X	X	0	0	0	0
功率模块 630安培	X	X	0	0	0	0
功率模块 800安培	0	0	0	0	0	0
功率模块 1000安培	0	0	0	0	0	0
功率模块 1300安培	0	0	0	0	0	0
功率模块 1700安培	0	0	0	0	0	0
功率模块 2000安培 (风冷)	0	0	0	0	0	0
功率模块 2000安培 (水冷)	0	0	X	X	0	0
功率模块 3000安培	0	0	X	X	0	0
功率模块 4000安培	0	0	X	X	0	0
0	表示该有毒有害物质在该部件所有均质材料中的含量均在SJ/T11363-2006标准规定的限量要求以下。					
X	表示该有毒有害物质至少在该部件的某一均质材料中的含量超出SJ/T11363-2006标准规定的限量要求。					

English

Restricted Materials Table						
Product	Toxic and hazardous substances and elements					
	Pb	Hg	Cd	Cr(VI)	PBB	PBDE
EPower						
Driver	X	0	X	0	0	0
Power Module 50A	X	X	0	0	0	0
Power Module 100A	X	X	0	0	0	0
Power Module 160A	X	X	0	0	0	0
Power Module 250A	X	X	0	0	0	0
Power Module 400A	X	X	0	0	0	0
Power Module 500A	X	X	0	0	0	0
Power Module 630A	X	X	0	0	0	0
Power Module 800A	0	0	0	0	0	0
Power Module 1000A	0	0	0	0	0	0
Power Module 1300A	0	0	0	0	0	0
Power Module 1700A	0	0	0	0	0	0
Power Module 2000A (air cooled)	0	0	0	0	0	0
Power Module 2000A (water cooled)	0	0	X	X	0	0
Power Module 3000A	0	0	X	X	0	0
Power Module 4000A	0	0	X	X	0	0
0	Indicates that this toxic or hazardous substance contained in all of the homogeneous materials for this part is below the limit requirement in SJ/T11363-2006.					
X	Indicates that this toxic or hazardous substance contained in at least one of the homogeneous materials used for this part is above the limit requirement in SJ/T11363-2006.					

Approval

Name:	Position:	Signature:	Date:
Martin Greenhalgh	Quality Manager	<i>Martin Greenhalgh</i>	17 th Dec 2009

INSTALLATION AND OPERATION MANUAL

LIST OF SECTIONS

1 INTRODUCTION	13
2 INSTALLATION	14
3 OPERATOR INTERFACE	45
4 QUICKSTART	45
5 OPERATOR MENU	52
6 ENGINEER AND CONFIGURATION LEVEL MENUS	55
7 USING ITOOLS	123
8 PARAMETER ADDRESSES (MODBUS)	151
9 PREDICTIVE LOAD MANAGEMENT OPTION	186
10 ALARMS	211
11 TECHNICAL SPECIFICATION	214
12 MAINTENANCE	220
APPENDIX A REMOTE DISPLAY UNIT	223
APPENDIX B THREE PHASE FEEDBACK	249
INDEX	255

Associated Documents

HA179770 Communications Manual

HA028838 iTools help manual

Software Effectivity

This manual relates to units with software version 3.05

Patents

This product is covered by one or the more of the following patents:

France: FR 06/02582 (Published 2899038)

Europe: 07104780.7 (Pending)

US: 11/726,906 (Pending)

China: 200710089399.5 (Pending)

TABLE OF CONTENTS

Section	Page
List of Sections	i
ASSOCIATED DOCUMENTS	i
SOFTWARE EFFECTIVITY	i
USER GUIDE	13
1 INTRODUCTION	13
1.1 UNPACKING THE UNITS	13
2 INSTALLATION	14
2.1 MECHANICAL INSTALLATION	14
2.1.1 Fixing details	14
GENERAL	14
2.2 ELECTRICAL INSTALLATION	20
2.2.1 Driver Module	20
SUPPLY VOLTAGE	20
FAN SUPPLIES	20
ENABLE INPUT	20
SAFETY EARTH	21
SIGNAL WIRING	22
WATCHDOG RELAY	24
RELAY 1	24
PREDICTIVE LOAD MANAGEMENT OPTION CONNECTOR	25
CONFIGURATION PORT	26
COMMUNICATIONS PINOUTS	27
2.2.2 Power modules	30
LINE/LOAD CABLES	30
RIBBON CABLE	30
EXTERNAL CURRENT FEEDBACK	30
REMOTE VOLTAGE INPUT	31
NEUTRAL/PHASE REFERENCE INPUT	31
ACCESS TO LINE AND LOAD TERMINATIONS	32
THREE-PHASE STAR CONFIGURATIONS	37
THREE-PHASE DELTA CONFIGURATIONS	38
TWO-LEG CONFIGURATIONS	39
THREE PHASE CONFIGURATIONS WITH EXTERNAL FEEDBACK	40
3 OPERATOR INTERFACE	42
3.1 DISPLAY	42
3.2 PUSHBUTTONS	42
3.2.1 Configuration	42
3.2.2 Operation	42
3.2.3 Menu item value selection	42
3.3 BEACONS	43
3.4 FRONT PANEL MESSAGES	43
3.4.1 Instrument events	43
3.4.2 Indication alarms	43
3.4.3 System alarms	43
3.4.4 Process alarms	43
3.4.5 Configuration errors	44
3.4.6 Standby errors	44

TABLE OF CONTENTS (CONT.)

Section	Page
3.4.7 Power module errors	44
3.4.8 General errors	44
3.4.9 Reset errors	44
3.4.10 Fatal errors	44
4 QUICKSTART	45
4.1 QUICKSTART MENU PARAMETERS	46
4.2 SOME DEFINITIONS	48
4.2.1 Firing modes	48
LOGIC	48
BURST FIXED FIRING	48
BURST VARIABLE FIRING	49
PHASE ANGLE CONTROL	49
HALF CYCLE MODE	49
4.2.2 Feedback type	50
4.2.3 Transfer Mode	51
4.2.4 Limitation features	51
FIRING ANGLE LIMITING	51
DUTY CYCLE LIMITING	51
5 OPERATOR MENU	52
5.1 SUMMARY PAGES	52
5.1.1 Single phase summary page	52
5.1.2 Two or three phase summary page	52
5.1.3 Two by two phase summary page	52
5.2 TOP LEVEL OPERATOR (USER) MENU	53
5.2.1 Alarm Summary pages	53
5.2.2 Event Log	53
5.2.3 Strategy Standby mode	54
6 ENGINEER AND CONFIGURATION LEVEL MENUS	55
6.1 ACCESS TO THE ENGINEER AND CONFIGURATION MENUS	55
6.1.1 Engineer level menu	55
6.1.2 Configuration level menu	56
6.2 TOP LEVEL MENU	57
6.3 ACCESS MENU	58
6.3.1 Engineer level menu	58
6.3.2 Configuration level access menu	59
GOTO MENU	59
PASS CODE EDITING	60
6.4 ANALOGIP MENU	61
6.4.1 Analogue input parameters	61
6.5 ANALOGOP MENU	62
6.5.1 Analogue output 'Main' submenu parameters	62
6.5.2 Analogue output 'Alm' parameters	63
6.6 COMMS MENU	64
6.6.1 Communications User menu parameters	65
6.6.2 COMMS REMOTE PANEL PARAMETERS	66
6.7 CONTROL MENU	67
6.7.1 Control Setup Parameters	68

TABLE OF CONTENTS (CONT.)

Section	Page
6.7.2 Control Main Parameters	69
6.7.3 Control Limit parameters	70
6.7.4 Control Diag parameters	71
6.7.5 Control Alarm disable parameters	72
6.7.6 Control Alarm detection parameters	73
6.7.7 Control Alarm signalling parameters	74
6.7.8 Control Alarm Latch parameters	75
6.7.9 Control Alarm Acknowledgement parameters	76
6.7.10 Control Alarm Stop parameters	77
6.8 COUNTER MENU	78
6.8.1 Counter configuration menu	78
6.8.2 Cascading counters	79
6.9 DIGITAL I/O MENU	80
6.10 ENERGY	81
6.10.1 Energy counter parameters	82
6.10.2 Resolution	83
6.11 EVENT LOG MENU	83
6.12 FAULT DETECTION MENU	84
6.13 FIRING OUTPUT MENU	85
6.14 INSTRUMENT MENU	87
6.14.1 Instrument Display parameters	87
6.14.2 Instrument Config parameters	88
6.15 IP MONITOR MENU	89
6.16 LGC2 (TWO INPUT LOGIC OPERATOR) MENU	91
6.16.1 Lgc2 Parameters	91
6.17 LGC8 (EIGHT-INPUT LOGIC OPERATOR) MENU	93
6.18 MATH2 MENU	94
6.19 MODULATOR MENU	96
6.20 NETWORK MENU	97
6.20.1 Meas submenu	98
6.20.2 Network Setup Submenu	100
PARTIAL LOAD FAILURE CALCULATIONS	102
6.20.3 Network alarms	103
NETWORK ALMDIS SUBMENU	103
NETWORK ALMDET SUBMENU	104
NETWORK ALMSIG SUBMENU	104
NETWORK ALMLAT SUBMENU	104
NETWORK ALMACK SUBMENU	104
NETWORK ALMSTOP SUBMENU	104
6.21 PLM (STATION AND NETWORK LM PARAMETERS) MENU	105
6.21.1 Main	105
6.21.2 Predictive Load management 'Station' menu	107
6.21.3 Predictive Load Management 'Network' menu	108
6.21.4 Predictive Load Management 'Alarm' menus	109
6.22 PLMCHAN (LOAD MANAGEMENT OPTION INTERFACE) MENU	110
6.23 LOAD TAP CHANGER (LTC) OPTION	111
6.23.1 MainPrm parameters	112

TABLE OF CONTENTS (CONT.)

Section	Page
6.23.2 LTC Alarm	112
PARAMETERS	112
6.23.3 LTC Application wiring	113
6.24 RELAY MENU	116
6.24.1 Relay parameters	116
6.25 SETPROV MENU	117
6.25.1 Setpoint provider parameters	118
6.26 TIMER MENU	119
6.26.1 Timer configuration	119
6.26.2 Timer examples	120
6.27 TOTALISER MENU	121
6.28 USER VALUE MENU	122
7 USING ITOOLS	123
7.1 iTools CONNECTION	123
7.1.1 Serial communications	123
7.1.2 Ethernet (Modbus TCP) communications	124
7.1.3 Direct Connection	126
WIRING	126
7.2 SCANNING FOR INSTRUMENTS	127
7.3 GRAPHICAL WIRING EDITOR	128
7.3.1 Toolbar	129
7.3.2 Wiring editor operating details	129
COMPONENT SELECTION	129
BLOCK EXECUTION ORDER	129
FUNCTION BLOCKS	130
WIRES	132
THICK WIRES	133
COMMENTS	133
MONITORS	134
DOWNLOADING	134
COLOURS	135
DIAGRAM CONTEXT MENU	135
COMPOUNDS	136
TOOL TIPS	137
7.4 PARAMETER EXPLORER	138
7.4.1 Parameter explorer detail	139
7.4.2 Explorer tools	140
7.5 FIELDBUS GATEWAY	141
EE CHECKSUM FAIL ERROR	142
7.6 DEVICE PANEL	145
7.7 WATCH/RECIPE EDITOR	146
7.7.1 Creating a Watch List	146
ADDING PARAMETERS TO THE WATCH LIST	146
DATA SET CREATION	146
7.7.2 Watch Recipe toolbar icons	147
7.7.3 Watch/Recipe Context Menu	147
7.8 USER PAGES	148

TABLE OF CONTENTS (CONT.)

Section	Page
7.8.1 User Page creation	148
7.8.2 Style examples	149
7.8.3 User Pages Tools	150
8 PARAMETER ADDRESSES (MODBUS)	151
8.1 INTRODUCTION	151
8.2 PARAMETER TYPES	151
8.3 PARAMETER SCALING	152
8.3.1 Conditional scaling	152
8.4 PARAMETER TABLE	153
9 PREDICTIVE LOAD MANAGEMENT OPTION	186
9.1 GENERAL DESCRIPTION	186
9.1.1 Load Management layout	186
9.1.2 Power modulation and accuracy	187
9.2 LOAD SEQUENCING	188
9.2.1 Incremental control type 1	188
9.2.2 Incremental control type 2	189
9.2.3 Rotating Incremental control	190
9.2.4 Distributed control	191
9.2.5 Incremental/Distributed control	191
9.2.6 Rotating Incremental Distributed control	192
9.3 LOAD SHARING	193
9.3.1 Total power demand	193
9.3.2 Sharing Efficiency Factor (F)	193
9.3.3 Sharing algorithm	194
9.4 LOAD SHEDDING	195
9.4.1 Definitions	195
9.4.2 Reduction of power demand	195
SHEDDING ABILITY FACTOR	196
9.4.3 Load shedding comparisons	197
WITHOUT LOAD SHARING, SYNCHRONISED	197
WITHOUT LOAD SHARING, SYNCHRONISED, REDUCTION FACTOR 50% ..	198
WITHOUT LOAD SHARING NOT SYNCHRONISED	198
WITHOUT LOAD SHARING, NON-SYNCHRONISED, REDUCTION FACTOR 50%	199
WITH LOAD SHARING	199
WITH LOAD SHARING, REDUCTION FACTOR = 50%	200
9.5 CONFIGURATION	201
9.5.1 iTools Graphical wiring	201
STANDARD POWER CONTROL LOOP	201
LOAD MANAGEMENT CHANNELS (LMCHAN 1 TO LMCHAN 4)	201
GLOBAL LOAD MANAGEMENT CONTROL (LOADMNG)	201
CALCULATION AND COMMUNICATIONS	201
9.5.2 Predictive Load Management function block details	204
LM TYPE	204
PERIOD	204
ADDRESS	205
Ps	205
SHEDFACTOR	205

TABLE OF CONTENTS (CONT.)

Section	Page
GROUP	206
PZMAX	206
STATUS	206
NUMCHAN	207
TOTALSTATION	207
TOTALCHANNELS	207
PMAX	208
PT	208
PR	208
EFFICIENCY	208
MASTER ADDRESS	209
9.6 MASTER ELECTION	209
9.6.1 Master Election triggers	209
9.7 ALARM INDICATION	210
PROVERPS	210
9.8 TROUBLE SHOOTING	210
9.8.1 Wrong Station status	210
DUPLICATE LM ADDRESS	210
STATION STATUS PERMANENTLY 'PENDING'	210
STATION TYPE MISMATCH	210
10 ALARMS	211
10.1 SYSTEM ALARMS	211
10.1.1 Missing mains	211
10.1.2 Thyristor short circuit	211
10.1.3 Thyristor open circuit	211
10.1.4 Fuse blown	211
10.1.5 Over temperature	211
10.1.6 Network dips	211
10.1.7 Mains frequency fault	211
10.1.8 Power board 24V fail	211
10.2 PROCESS ALARMS	212
10.2.1 Total Load Failure (TLF)	212
10.2.2 Output short circuit	212
10.2.3 Chop Off	212
10.2.4 Mains Voltage Fault	212
10.2.5 Temperature pre-Alarm	212
10.2.6 Partial Load Failure (PLF)	213
10.2.7 Partial Load Unbalance (PLU)	213
10.3 INDICATION ALARMS	213
10.3.1 Process Value Transfer active	213
10.3.2 Limitation active	213
10.3.3 Load Over-Current	213
10.3.4 Over Load Shedding (Ps over Pr) alarm	213
11 TECHNICAL SPECIFICATION	214
12 MAINTENANCE	220
12.1 SAFETY	220
12.2 PREVENTIVE MAINTENANCE	220

TABLE OF CONTENTS (CONT.)

Section	Page
12.3 THYRISTOR PROTECTION FUSES	221
APPENDIX A REMOTE DISPLAY UNIT	223
A1 INTRODUCTION	223
A1.1 SAFETY AND EMC INFORMATION NOTES	223
SYMBOLS	224
A2 MECHANICAL INSTALLATION	225
A3 ELECTRICAL INSTALLATION	226
A3.1 PINOUT	226
A3.2 WIRING	226
SUPPLY VOLTAGE RANGE	226
ANALOGUE (MEASURING) INPUTS	227
OUTPUT WIRING	227
A3.3 OVER TEMPERATURE APPLICATION WIRING	228
A4 FIRST SWITCH ON	229
A5 OPERATING MODE	230
A5.1 FRONT PANEL LAYOUT	230
REM/MAN BEACONS	232
A5.2 LEVEL 1 OPERATION	232
A5.3 LEVEL 2 OPERATION	236
A5.4 LEVEL 3 AND CONF LEVEL OPERATION	239
AUTO SCROLLING	241
A6 OTHER FEATURES	242
A6.1 ALARMS AND ERRORS	242
A6.2 RECIPES	244
A6.3 EPOWER SETPROV CONFIGURATIONS	244
MULTIPLE SINGLE PHASE CONFIGURATION	245
A6.4 PV RETRANSMISSION	245
A6.5 DIGITAL ALARM OPTIONS	246
A6.6 HOME PAGE TIMEOUT	246
APPENDIX B THREE PHASE FEEDBACK	249
B1 TRANSFORMER REPRESENTATION AND LABELLING	249
B2 EXTERNAL FEEDBACK PHASING	249
B2.1 CURRENT TRANSFORMER CONNECTION	250
B2.2 FEEDBACK EXAMPLES FOR TYPICAL THREE PHASE NETWORKS	251
B2.2.1 Two phase control with Delta-Star transformer and 3S load	251
B2.2.2 Two phase control with Delta-Star transformer and 3D load	251
B2.2.3 Three phase control with Delta-Star transformer and 3S load	252
B2.2.4 Three phase control with Delta-Star transformer and 3D load	252
B2.2.5 Three phase control with Star-Star transformer and 4S load	253
B2.2.6 Three phase control with Delta-Delta transformer and 3S load	253
B2.2.7 Three phase control with 6D primary and 4S secondary with 4S load ...	254
B2.2.8 Three phase control with 6D primary /secondary with three independent loads	254
Index	255

TABLE OF CONTENTS (CONT.)

Section

Page

This page is deliberately left blank

SAFETY NOTES

WARNINGS

1. BRANCH-CIRCUIT PROTECTION AND SAFETY OVERLOAD PROTECTION

This product does not contain any branch-circuit protection or internal safety overload protection. It is the responsibility of the user to add branch-circuit protection upstream of the unit. It is also the responsibility of the user to provide external or remote safety overload protection to the end installation. Such branch-circuit and safety overload protection must comply with applicable local regulations.

UL: The abovementioned branch-circuit protection is necessary for compliance with National Electric Code (NEC) requirements.

2. If opening of the branch circuit protective or the supplemental fuses (high speed fuse) EPower shall be examined and replaced if damaged.
3. This equipment is not suitable for isolation applications, within the meaning of EN60947-1.
4. The instrument shall have one of the following as a disconnecting device, fitted within easy reach of the operator, and labelled as the disconnecting device.
 - a. A switch or circuit breaker which complies with the requirements of IEC60947-1 and IEC60947-3
 - b. A separable coupler which can be disconnected without the use of a tool.
5. EPower alarms protect thyristors and loads against abnormal operation, and provide the user with valuable information regarding the type of fault. Under no circumstances should these alarms be regarded as a replacement for proper personnel protection. It is strongly recommended that the installing authority include independent, system-safety mechanisms to protect both personnel and equipment against injury or damage, and that such safety mechanisms be regularly inspected and maintained. Consult the EPower supplier for advice.
6. Units are designed to be installed in a cabinet connected to the protective earth according to IEC60364-1 and IEC60364-5-54 or applicable national standards.
7. The cabinet must be closed under normal operating conditions. Adequate air conditioning/ filtering/ cooling equipment must be fitted to the cabinet in order to prevent the ingress of conductive pollution, the formation of condensation etc.
8. Before any other connection is made, the protective earth terminal shall be connected to a protective conductor.
9. The earth connection must be made using the correct size of terminal and correct gauge of cable, as given in table 2.2.1.

U.L.: Wire conductor cross sections must comply with NEC requirements. Used cables must be rated 75°C stranded copper only. Connection must be made by using listed lugs
10. The earth connection should be tightened at the torque defined in table 2.2.1. It is recommended to perform regular inspection of the earth tightening
11. Any interruption of the protective conductor inside or outside the apparatus, or disconnection of the protective earth terminal is likely to make the apparatus dangerous under some fault conditions. Intentional interruption is prohibited.
12. Whenever it is likely that protection has been impaired, the unit shall be made inoperative, and secured against accidental operation. The manufacturers nearest service center should be contacted for advice.
13. Before carrying out any wiring to the unit it must be ensured that all relevant power and control cables, leads or harnesses are isolated from voltage sources.
14. Power connections. CE: Wire conductor cross sections must comply with table 9 & 10 of IEC60947-1 (see table 2.2.2).

UL: Wire conductor cross sections must comply with NEC requirements. Used cables must be rated 75°C stranded copper only. Connection must be made by using listed lugs









15. Power terminals should be tightened according to the torque values defined in table 2.2.2. It is recommended to perform regular inspection of the power terminals tightening.
16. It must be ensured that the remote voltage sensing inputs (if fitted) and for 4S, 6D and two-leg configurations the reference input are correctly fused. It is the responsibility of the user to add branch-circuit protection. Such branch-circuit must comply with applicable local regulations.
UL: The above mentioned branch-circuit protection is necessary for compliance with National Electric Code (NEC) requirements.
17. The Auxiliary (Fan) supply is Installation category II. U.L.: supply to Auxiliary (Fan) supply shall be provided by isolated transformer secondary grounded protected by a Listed 20A branch circuit fuse.
18. The mains supply fuse within the Driver Module is not replaceable. If it is suspected that the fuse is faulty, the manufacturer's local service center should be contacted for advice.
19. Units are designed to be mounted vertically. There must be no obstructions (above or below) which could reduce or hamper airflow. If more than one set of units is located in the same cabinet, they must be mounted in such a way that air from one unit is not drawn into another.
20. If the equipment is used in a manner not specified by the manufacturer, the protection provided by the equipment might be impaired.
21. Any adjustment, maintenance and repair of the opened apparatus under voltage, is forbidden for safety reasons.
22. Under some circumstances, the power module heatsink temperature may rise above 50 degrees Celsius. If operators are likely to come into contact with such heatsinks, adequate warnings and barriers must be put in place in order to prevent injury.
23. In order to maintain protection against electrostatic discharge, any scratched or damaged inter module ribbon cables must be replaced.
24. Signal and power voltage wiring must be kept separate from one another. Where this is impractical, shielded cables should be used for the signal wiring.
25. This product has been designed for environment A (Industrial). Use of this product in environment B (domestic, commercial and light industrial) may cause unwanted electromagnetic disturbances in which cases the user may be required to take adequate mitigation measures.

SELV

Safety Extra Low Voltage. This is defined (in EN60947-1) as an electrical circuit in which the voltage cannot exceed 'ELV' under normal conditions or under single fault conditions, including earth faults in other circuits. The definition of ELV is complex as it depends on environment, signal frequency etc. See IEC 61140 for further details.

SYMBOLS USED ON THE INSTRUMENT LABELLING

One or more of the symbols below may appear as a part of the instrument labelling.

	Protective-conductor terminal		Risk of electric shock
	AC supply only		Precautions against static electrical discharge must be taken when handling this unit.
	Underwriters laboratories listed mark, for Canada and the U.S.		Refer to the manual for instructions
	Do not touch heatsink Hot Surface		Declaration of conformity to REuropen standard

USER GUIDE

1 INTRODUCTION

This document describes the installation, operation and configuration of an EPower 'station' (Driver Module plus one or more Power Modules). The Driver Module comes in one version, but the Power Modules are available in a number of different power ratings, which are identical in operation and configuration, but which differ in physical size according to the number of phases being controlled and the maximum current being supplied. All but the 50 Amp and 100 Amp unit come with cooling fans attached.

The Driver Module includes the following analogue and digital inputs and outputs, fitted as standard:

10V supply

Two analogue inputs

One analogue output

Two digital Inputs/Outputs.

One change-over relay under software control, configurable by the user.

Also fitted are a Watchdog relay, a configuration port and an isolated EIA485 port for attaching an optional Remote Display.

Three further (optional) I/O modules may be fitted, similar to the standard module but with the addition of an output change-over relay. Other options provide for external voltage and current feedback and for predictive load management.

Section two of this manual gives connector locations and pinouts.

The operator interface consists of a display comprising four lines of 10-characters (where each character is formed using a 5 x 7 LCD dot matrix) and four push buttons for navigation and data selection.

1.1 UNPACKING THE UNITS

The units are despatched in a special pack, designed to give adequate protection during transit. If any of the outer boxes show signs of damage, they should be opened immediately, and the instrument examined. If there is evidence of damage, the instrument should not be operated and the local representative contacted for instructions.

After the instrument has been removed from its packing, the packing should be examined to ensure that all accessories and documentation have been removed. The packing should then be stored against future transport requirements.

2 INSTALLATION

2.1 MECHANICAL INSTALLATION

2.1.1 Fixing details

Units are designed to operate at an operating temperature not exceeding 40°C (unless the modules are derated - see [specification](#)). Units must be installed in a fan-cooled cabinet (with fan failure detection or thermal safety cutout). Condensation and conductive pollution should be excluded to IEC 60664-1 pollution degree 2. The cabinet must be closed and connected to the protective earth according to IEC 60634 or applicable national standard.

Units must be mounted with the heat sink vertical with no obstructions above or below which impede the airflow. Where more than one set of modules is enclosed in the same cabinet, they must be mounted such that air from one unit is not drawn in by another mounted above it. An air gap of at least 5 cm should be maintained between adjacent sets of modules.

The units are designed for fitting to the front face of a mounting panel using the fixings supplied. The thyristor power modules are heavy, so a Health and Safety risk assessment should be carried out before personnel attempt to lift the units. It should also be ensured, prior to fitting, that the mechanical strength of the panel is sufficient for the mechanical load being applied. Table 2.1.1 gives the weights of the various units.

GENERAL

Figure 2.1.1a, below, shows details of a generalised mechanical assembly for the top of the units. Assembly details for the bottom brackets is similar, except that there is no safety earth fixing. The power module shown is a 400 Amp unit for which the module is fixed to the support brackets using holes A and B. Lower current power modules use only one screw (C) to secure the module to the support bracket.

Current	Weight (including 2 kg (4.4 lb) for driver module)								Weights ± 50gm (2 oz)	
	1 phase		2 phases		3 phases		4 phases			
	kg	lb	kg	lb	kg	lb	kg	lb		
50/100 A	6.5	14.3	11.0	24.3	15.5	34.2	20.0	44.1	0.1	1.6
160 A	6.9	15.2	11.8	26.0	16.7	36.8	21.6	47.6	0.2	3.2
250 A	7.8	17.2	13.6	30.0	19.4	42.8	25.2	55.6	0.3	4.8
400 A	11.8	26.0	21.6	47.6	31.4	69.2	41.2	90.8	0.4	6.4
500 A	14.0	30.9	26.0	57.3	38.0	83.8	50.0	110.2	0.5	8.0
630 A	14.5	32.0	27.0	59.5	39.5	87.1	52.0	114.6	0.6	9.6

Table 2.1.1 Unit Weights

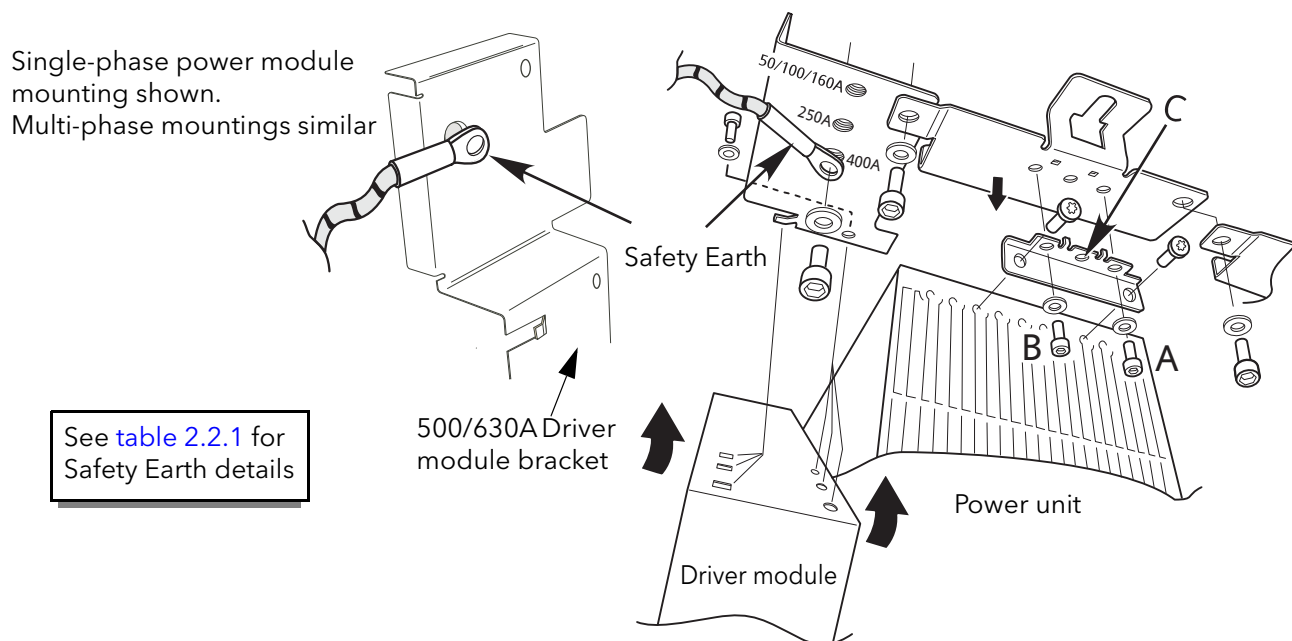

Figure 2.1.1a Bracket fixing details

2.1.1 FIXING DETAILS (Cont.)

Figures 2.1.1a to 2.1.1f show fixing centres and other mechanical details for the various modules.

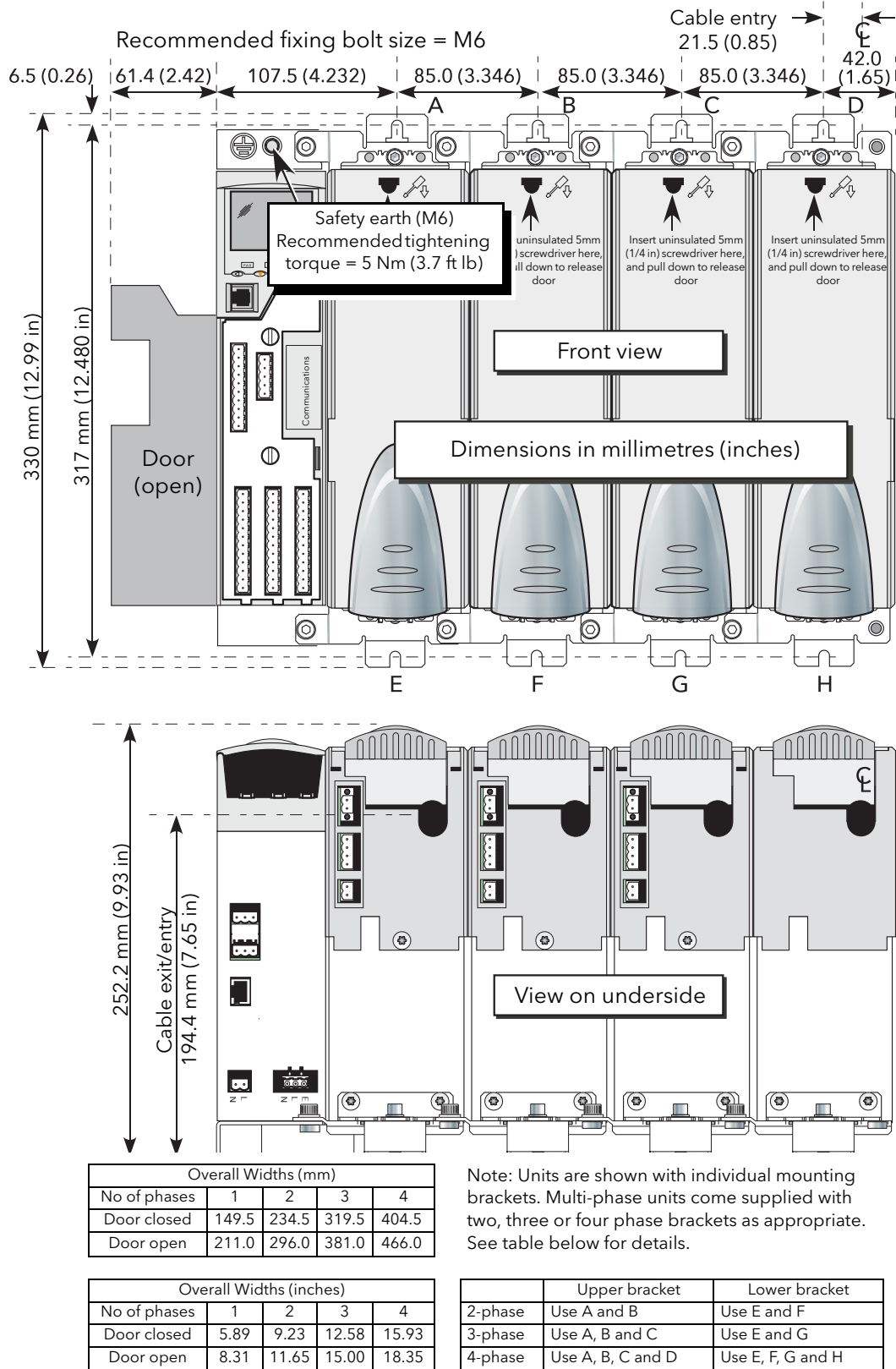
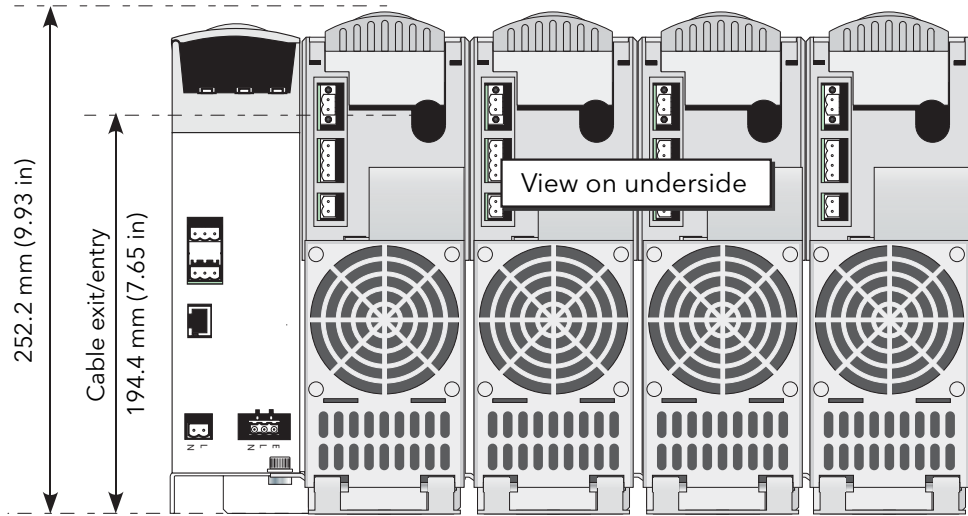
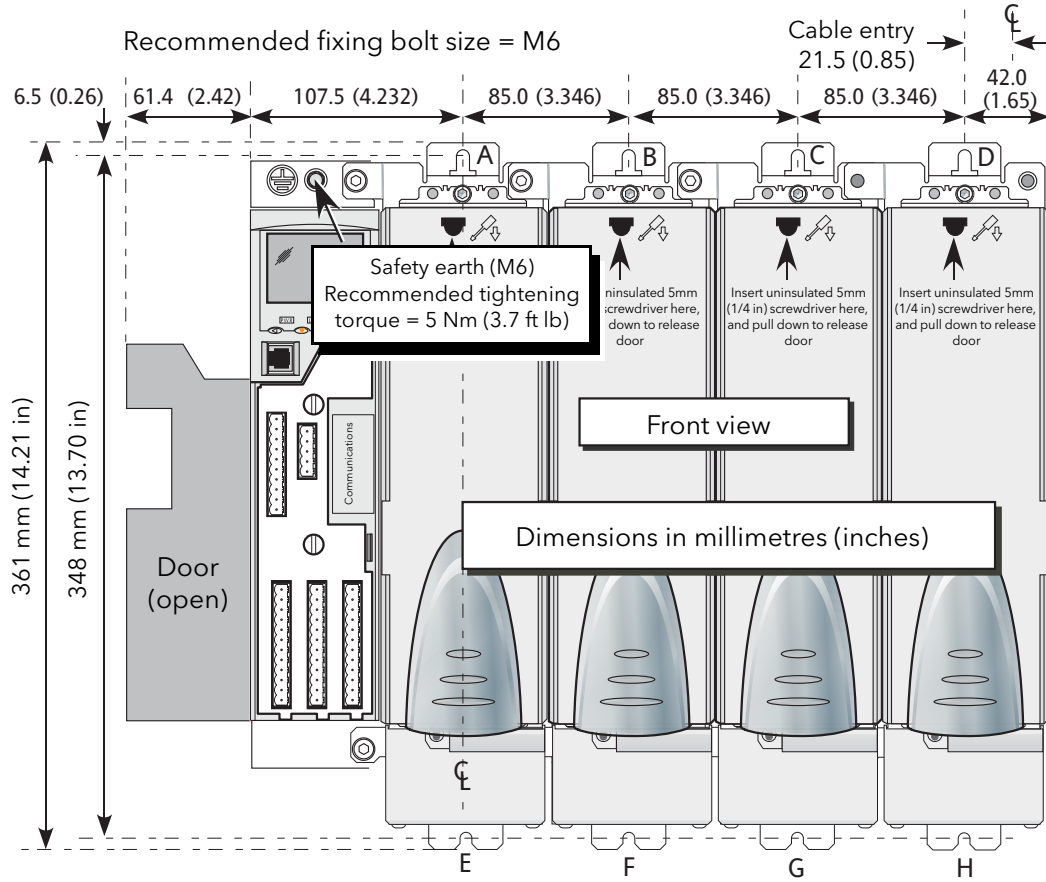

Figure 2.1.1b Fixing details (50 Amp and 100 Amp units)

2.1.1 FIXING DETAILS (Cont.)



Overall Widths (mm)				
No of phases	1	2	3	4
Door closed	149.5	234.5	319.5	404.5
Door open	211.0	296.0	381.0	466.0

Overall Widths (inches)				
No of phases	1	2	3	4
Door closed	5.89	9.23	12.58	15.93
Door open	8.31	11.65	15.00	18.35

Note: Units are shown with individual mounting brackets. Multi-phase units come supplied with two, three or four phase brackets as appropriate. See table below for details.

	Upper bracket	Lower bracket
2-phase	Use A and B	Use E and F
3-phase	Use A, B and C	Use E, F and G
4-phase	Use A, B, C and D	Use E, F, G and H

Figure 2.1.1c Fixing details (160 Amp unit)

2.1.1 FIXING DETAILS (Cont.)

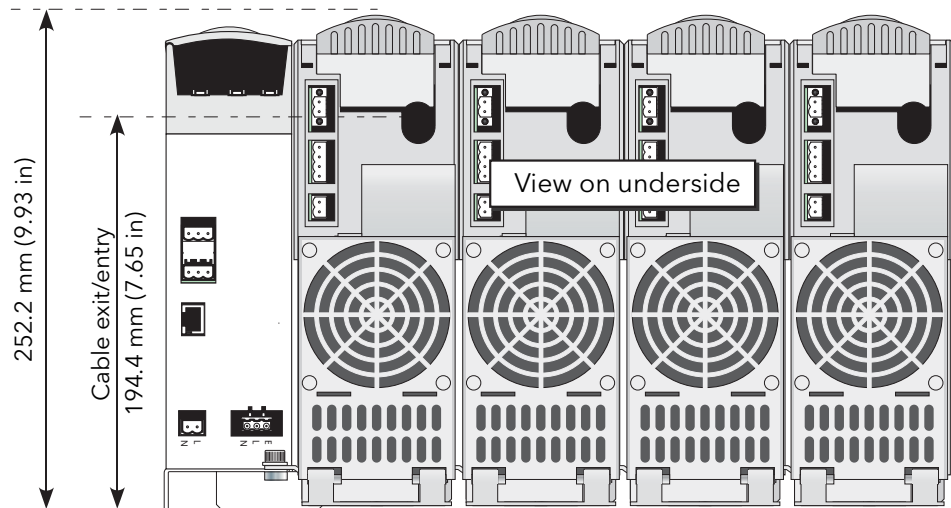
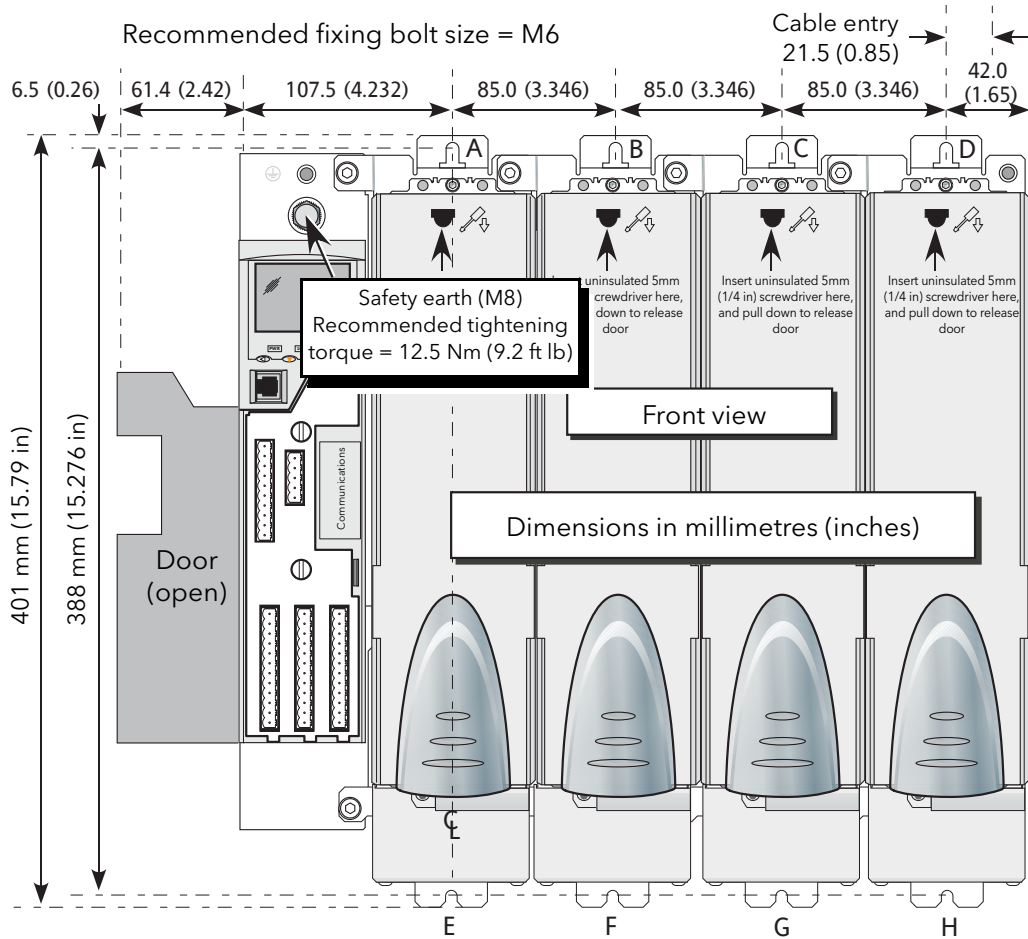

Overall Widths (mm)				
No of phases	1	2	3	4
Door closed	149.5	234.5	319.5	404.5
Door open	211.0	296.0	381.0	466.0

Overall Widths (inches)				
No of phases	1	2	3	4
Door closed	5.89	9.23	12.58	15.93
Door open	8.31	11.65	15.00	18.35

Note: Units are shown with individual mounting brackets. Multi-phase units come supplied with two, three or four phase brackets as appropriate. See table below for details.

	Upper bracket	Lower bracket
2-phase	Use A and B	Use E and F
3-phase	Use A, B and C	Use E, F and G
4-phase	Use A, B, C and D	Use E, F, G and H

Figure 2.1.1d Fixing details (250 Amp unit)

2.1.1 DIMENSIONAL DETAILS (Cont.)

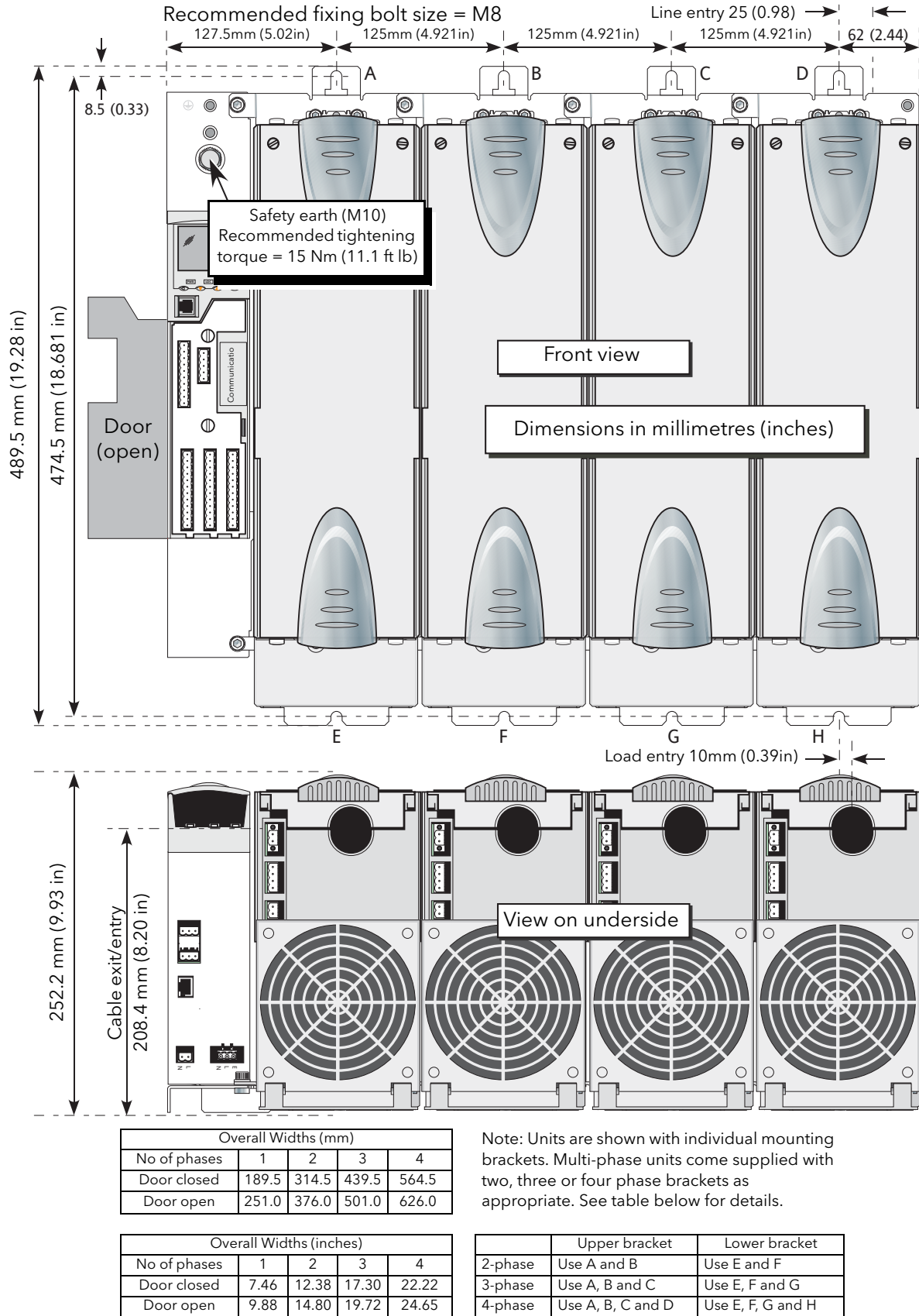
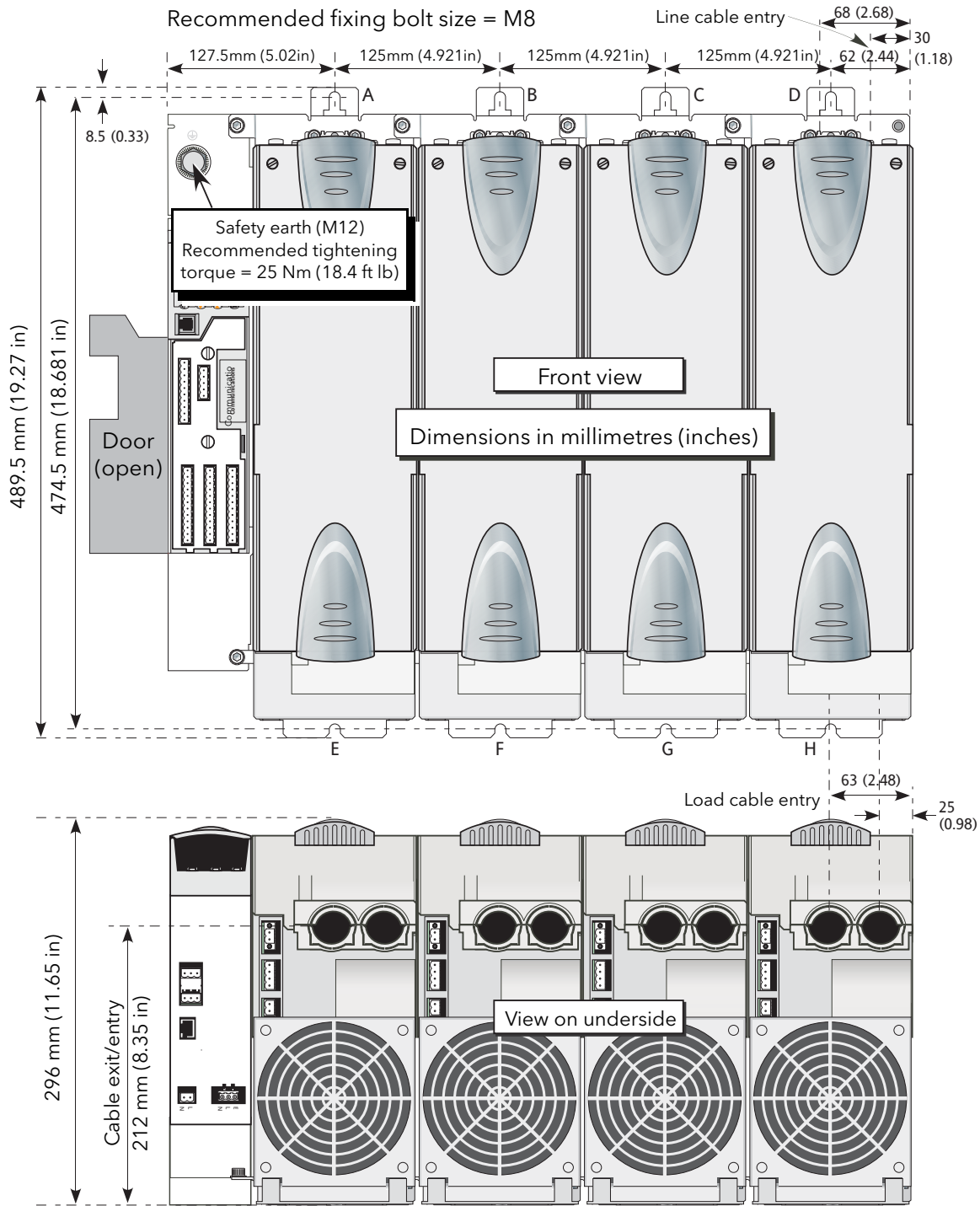

Figure 2.1.1e Fixing details (400 Amp unit)

2.1.1 DIMENSIONAL DETAILS (Cont.)



Overall Widths (mm)				
No of phases	1	2	3	4
Door closed	189.5	314.5	439.5	564.5
Door open	251.0	376.0	501.0	626.0

Overall Widths (inches)				
No of phases	1	2	3	4
Door closed	7.46	12.38	17.30	22.22
Door open	9.88	14.80	19.72	24.65

Note: Units are shown with individual mounting brackets. Multi-phase units come supplied with two, three or four phase brackets as appropriate. See table below for details.

	Upper bracket	Lower bracket
2-phase	Use A and B	Use E and F
3-phase	Use A, B and C	Use E, F and G
4-phase	Use A, B, C and D	Use E, F, G and H

Figure 2.1.1f Fixing details (500 Amp/630A units)

2.2 ELECTRICAL INSTALLATION

2.2.1 Driver Module

SUPPLY VOLTAGE

The Line and neutral supply voltage connections are terminated using a 2-way connector (SK8), located on the underside of the unit, as shown in figure 2.2.1a, below. It is recommended that a 3 Amp slow-blow fuse be incorporated in order to protect the supply voltage wiring.

The Auxiliary (Fan) supply is Installation category II, U.L.: supply to Auxiliary (Fan) supply shall be provided by isolated transformer secondary grounded protected by a Listed 20A branch circuit fuse.

FAN SUPPLIES

CAUTION

The Driver Module power supply is capable of working from any supply voltage between 85V ac to 265V ac. The fans (if fitted) on the power modules are specified for use at 115V ac or 230V ac, as defined at time of order. It must therefore be ensured that the fan voltage matches the supply voltage, or the fan will either fail within a short period, or it will be ineffective at cooling.

The three way connector (SK9) provides supply voltage for cooling fans which are fitted to all power modules except 50A and 100A modules. Suitable looms (harnesses) for the fans are supplied with the units. SK9 is not used for 50/100A modules, because there are no cooling fans.

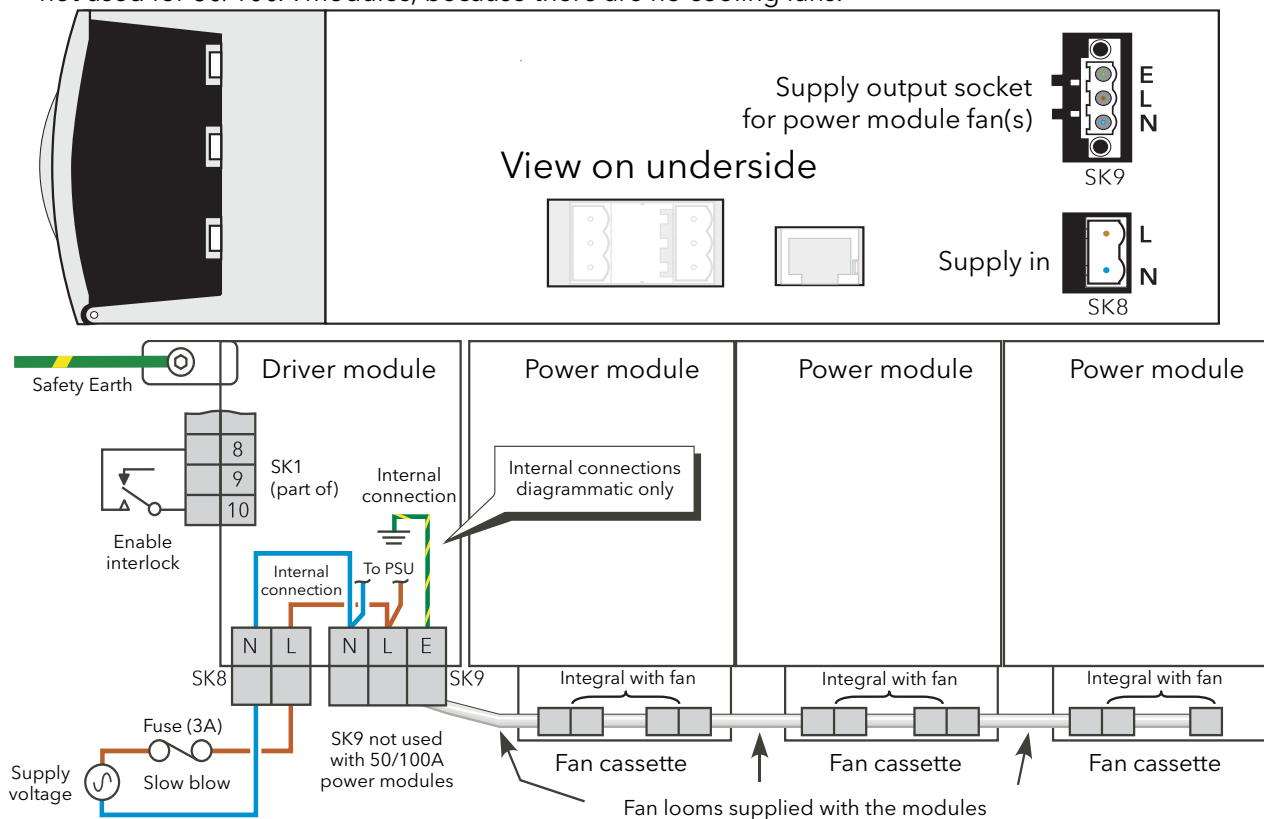

Figure 2.2.1a Driver module wiring

ENABLE INPUT

In order for the power module thyristors to operate, the Enable input to the driver module must be valid. In the default configuration, this is achieved by shorting pins 8 and 10 of SK1 (Digital input 1 - figure 2.2.1b), or by using a User Value block to apply a logic high to the enable input to the relevant firing block in iTools. If required, DI1 can be reconfigured as a voltage input, and in this case it requires a high signal (figure 2.2.1c) to be applied to SK1 pin8 with the relevant zero voltage connected to pin 10.

2.2.1 Driver Module (Cont.)

SAFETY EARTH

Before any other connection is made, the protective earth terminal shall be connected to a protective conductor.

The safety earth connection for the driver/power module set is made to the mounting bracket above the unit as shown in figures 2.1.1a to 2.1.1f, above.

The connection must be made using the correct size of terminal and correct gauge of cable, as given in table 2.2.1 below.

UL: Wire conductor cross sections must comply with NEC requirements. Used cables must be rated 75°C stranded copper only. Connection must be made by using listed lugs

The earth connection should be tightened at the torque defined in table 2.2.1. It is recommended to perform regular inspection of the earth tightening

Max. load current	Minimum earth cable cross-section.	Earth Terminal	
		Size	Tightening torque
50/100A	25 mm ²	M6	5 Nm (3.7 ft lb.)
160A	35 mm ²	M6	5 Nm (3.7 ft lb)
250A	70 mm ²	M8	12.5 Nm (9.2 ft lb)
400A	120 mm ²	M10	15 Nm (11.1ft lb)
500A	150 mm ²	M12	25 Nm (18.4 ft lb)
630A	185 mm ²	M12	25 Nm (18.4 ft lb)

Table 2.2.1 Safety Earth details

Any interruption of the protective conductor inside or outside the apparatus, or disconnection of the protective earth terminal is likely to make the apparatus dangerous under some fault conditions. Intentional interruption is prohibited.

Whenever it is likely that protection has been impaired, the unit shall be made inoperative, and secured against accidental operation. The manufacturers nearest service center should be contacted for advice.

SIGNAL WIRING

Figure 2.2.1b shows the location of the various connectors; pinouts and typical wiring for SK1 (fitted as standard) are shown in figure 2.2.1c. Wiring for optional I/O units (SK 3 to SK5) is similar, except that they contain a relay in addition to the analog and digital circuits, and the digital circuits are inputs only.

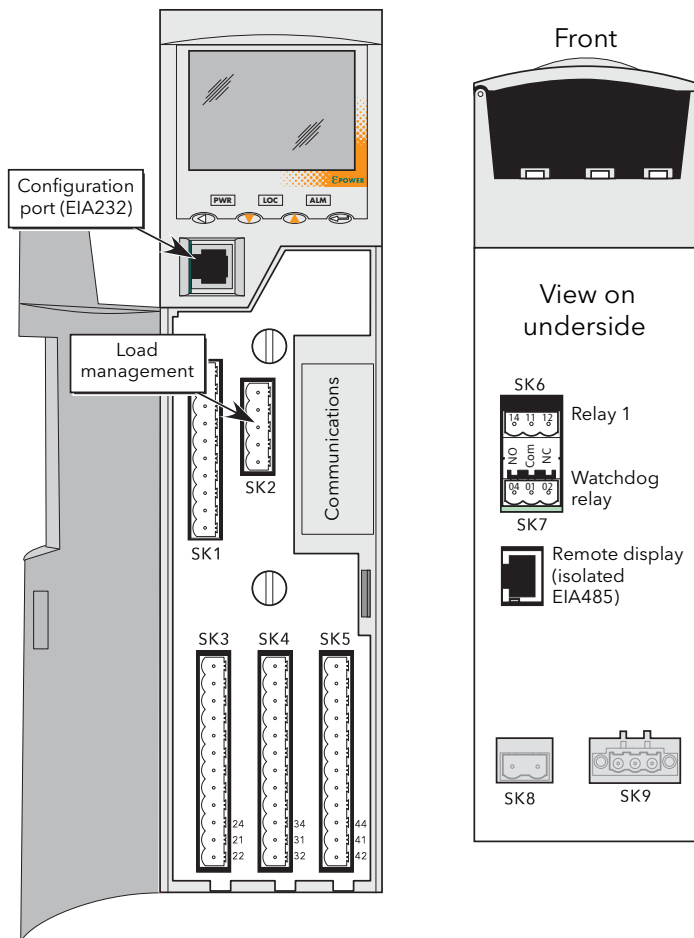
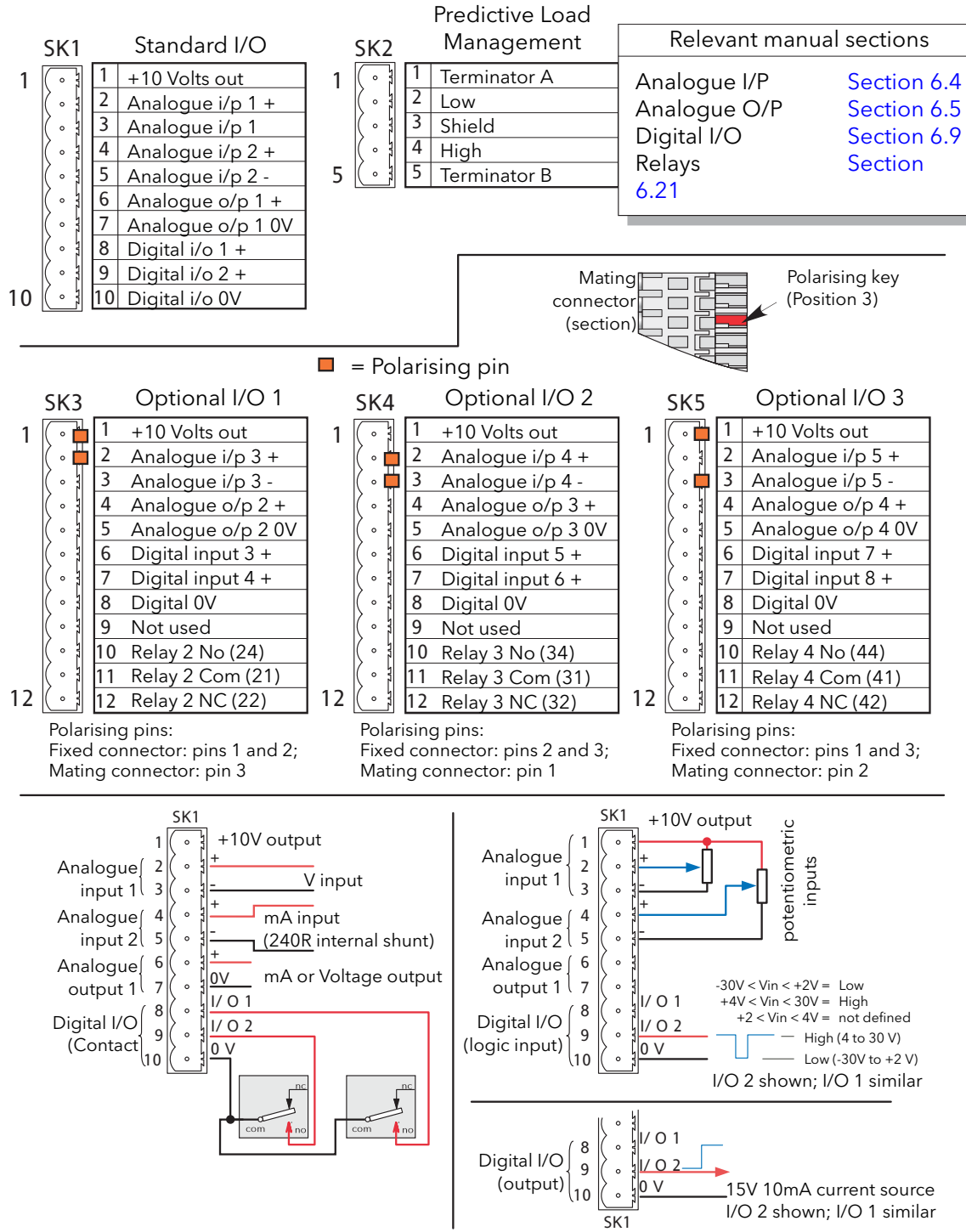

Figure 2.2.1b Connector locations

Note: It is physically possible to insert an RJ11 plug into an RJ45 socket. Care must therefore be taken to ensure that the Configuration port cable is not mistakenly plugged into an RJ45 communications connector (if fitted) or the Remote display connector.

2.2.1 Driver Module (Cont.)



- Notes:
- Analogue input type selected during configuration as one of: 0 to 5V, 0 to 10V, 1 to 5V, 2 to 10V, 0 to 20mA, 4 to 20mA
 - Analogue output type selected during configuration as one of: 0 to 5V, 0 to 10V, 0 to 20mA, 4 to 20mA. Resolution 12 bits; accuracy ±1% scale.
 - Each analogue input -ve terminal is individually connected to 0V via a 150 Ohm resistor.

Figure 2.2.1c Drive unit connector pinouts

2.2.1 Driver Module (Cont.)

WATCHDOG RELAY

The 'watchdog' relay is wired to a connector on the underside of the Driver Module (figure 2.2.1d).

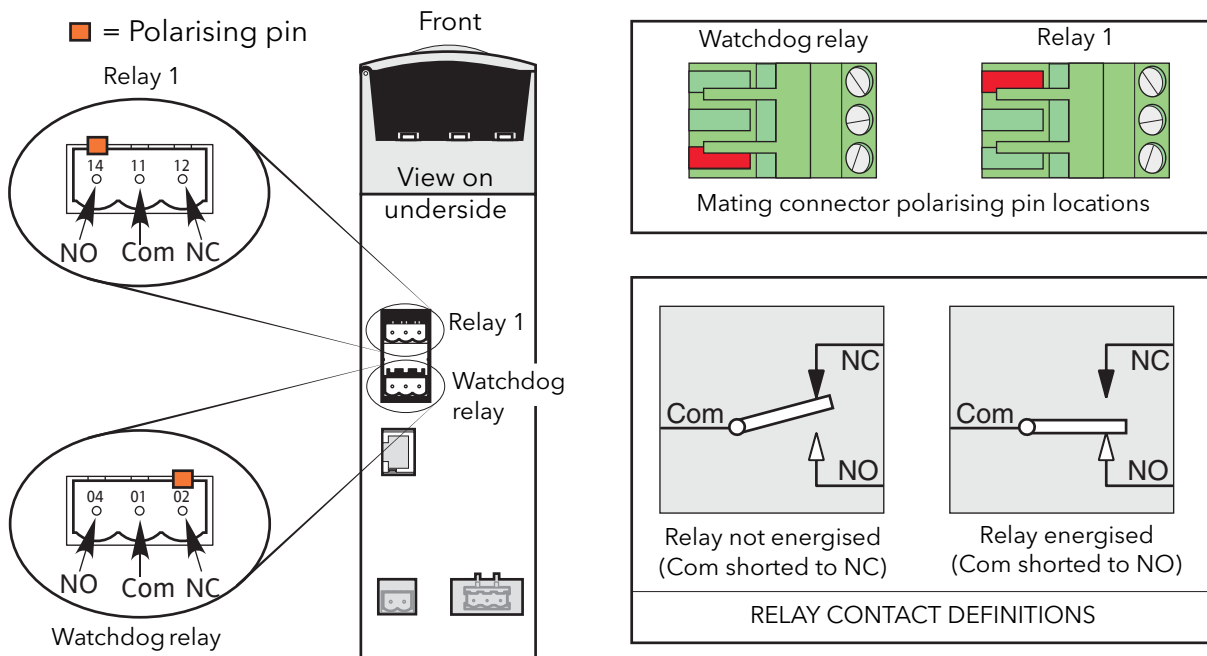

Figure 2.2.1d Relay connector location and pinout.

Under normal operating conditions, the watchdog relay is energised (that is the common and normally open contacts are shorted). Should a system error (listed below) become active (or power to the Driver Module fail), the relay is de-energised (common and normally closed contacts shorted).

1. Missing mains. One or more Power Module supply voltage lines is missing.
2. Thyristor short circuit*
3. Thyristor open circuit*
4. Fuse Blown. Thyristor-protection fuse ruptured in one or more Power Modules.
5. Unit over temperature
6. Network dips. A reduction in supply voltage exceeding a configurable value (VdipsThreshold), causes firing to be inhibited until the supply voltage returns to a suitable value. VdipsThreshold represents a percentage change in supply voltage between successive half cycles, and can be defined by the user in the Network.Setup menu, as described in [section 6.20.2](#).
7. Supply frequency fault. The supply frequency is checked every half cycle, and if the percentage change between successive 1/2 cycles exceeds a threshold value (max. 5%), a Mains Frequency System Alarm is generated. The threshold value (FreqDriftThold) is defined in the Network.Setup menu described in [section 6.20.2](#).
8. Power Module 24V Failure.

* Note: It is not possible to detect a thyristor short circuit when the unit is delivering 100% output power. Similarly, it is not possible to detect thyristor open circuit when the unit is delivering 0% output.

RELAY 1

This relay, supplied as standard, is located adjacent to the watchdog relay (figure 2.2.1d). The energisation/de-energisation of the relay coil is under software control and is fully configurable by the user. The terms Normally open (NO) and Normally closed (NC) refer to the relay in its de-energised state. Up to three further relays are available if optional I/O Modules are fitted (see figure 2.2.1c).

2.2.1 Driver Module (Cont.)

PREDICTIVE LOAD MANAGEMENT OPTION CONNECTOR

This option allows a number of systems to communicate with one another to allow load management techniques such as Load Sharing and Load Shedding to be implemented. The connector is located as shown in [figure 2.2.1b](#).

Note: Connecting pins 1 and 5 together has the effect of introducing a terminating (120 Ohm) resistor across pins 2 and 4. It is recommended that this be done at each end of the transmission line.

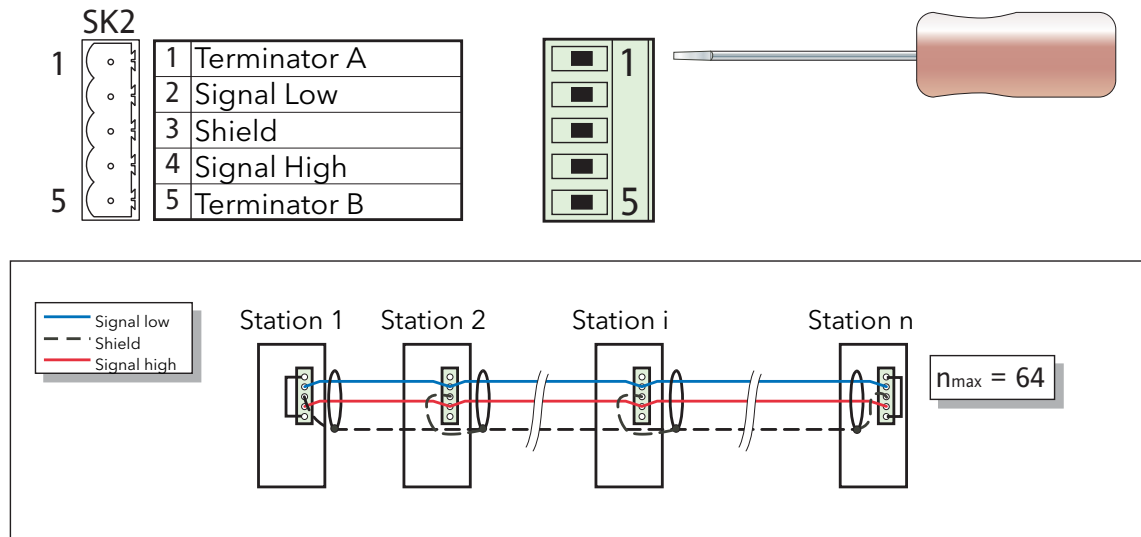

Maximum Trunk line length = 100 metres (328 ft)
 Maximum individual drop length = 5 metres (16 ft)
 Maximum cumulative drop length = 30 metres (98 ft)
 Conductor pair size = 24 gauge (0.25 mm²)
 Characteristic impedance at 500kHz = 120 Ohms \pm 10%
 Nominal capacitance @ 800Hz = \leq 40pF
 Unbalance capacitance = \leq 4 \pm 10%pF/m
 Capacitance between conductors = 100pF/metre)
 Attenuation at 500kHz = 1.64dB/100 metres)

Note: The figures above are for a network of up to 100 metres with up to 64 units connected. The actual network impedance is a function of cable type, cable length and the number of units connected. For further details contact the manufacturer or local agent.

Figure 2.2.1e Predictive Load Management wiring

Load Sharing

In a system with several heating zones, this allows a strategy to be implemented which distributes power over time in such a way that the overall power consumption remains as steady as possible, thus reducing the peak power demand of the system.

Load Shedding

In a system with several heating zones, this allows a strategy to be implemented which limits the available load power at each heating zone and/or switches zones off according to a defined priority level, thus allowing the maximum running power consumption to be controlled. The total running power is the maximum power supplied to the loads, integrated over a 50 minute period.

See the Predictive Load Management option description ([section 9](#)), for more details.

2.2.1 Driver Module (Cont.)

CONFIGURATION PORT

This RJ11 connector located on the front of the Driver Module (figure 2.2.1b) is used for direct connection to a PC using EIA232C standard.

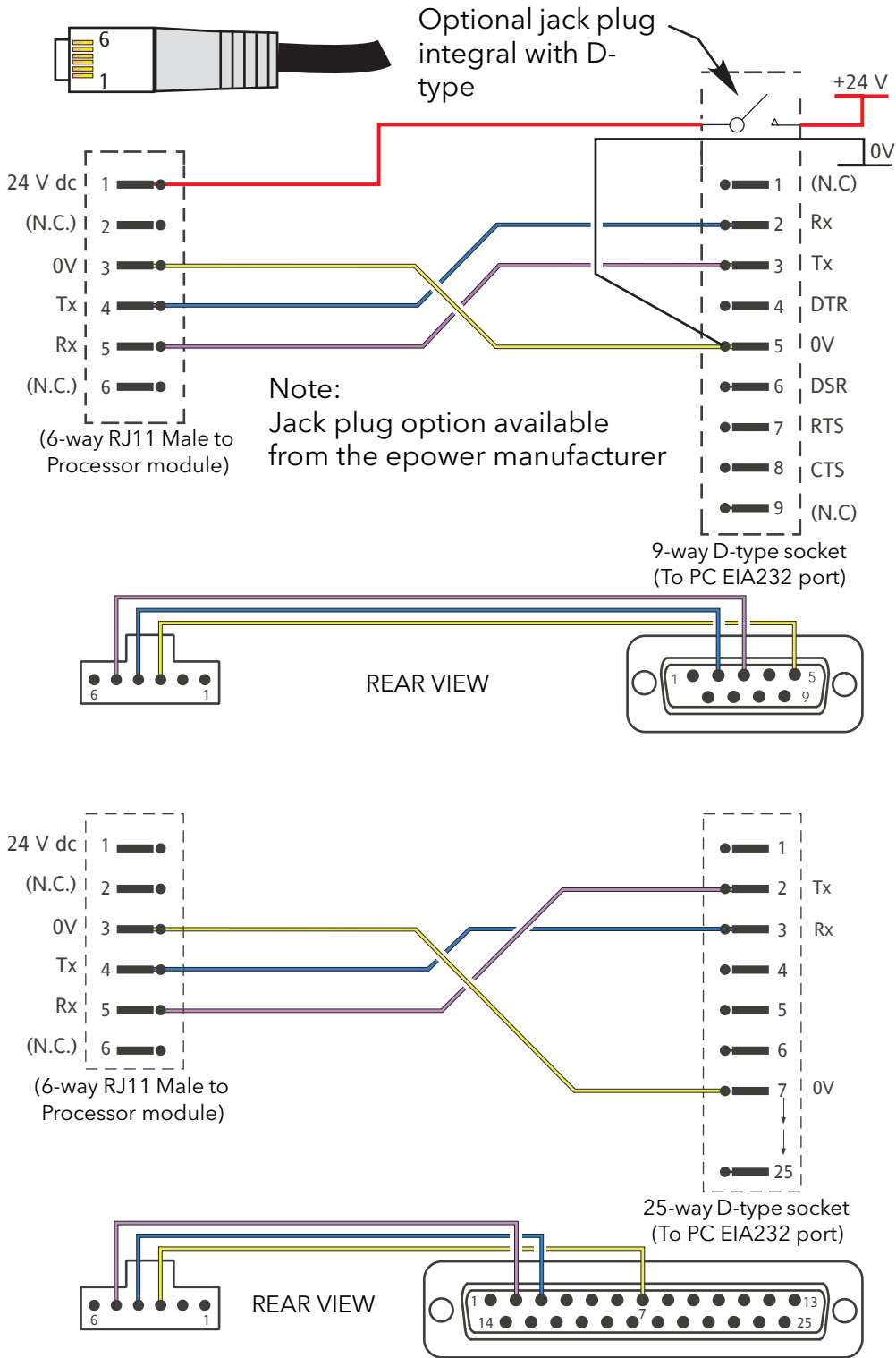

Figure 2.2.1f Configuration port wiring details

2.2.1 Driver Module (Cont.)

COMMUNICATIONS PINOUTS

Serial communications is discussed in the Communications Manual HA179770. Pinouts for the relevant protocols are given here for convenience.

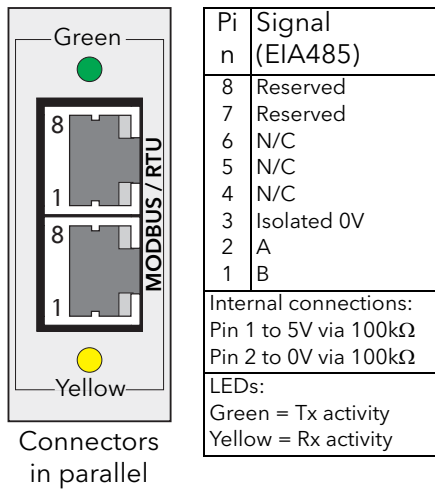

Figure 2.2.1g Modbus RTU pinout

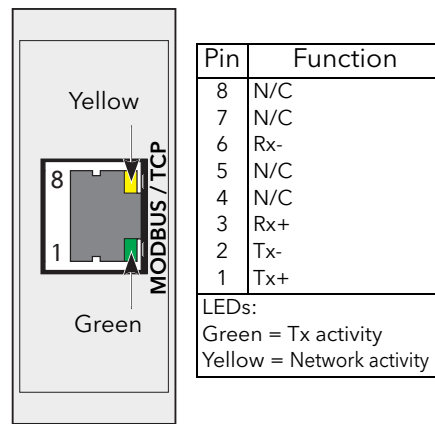
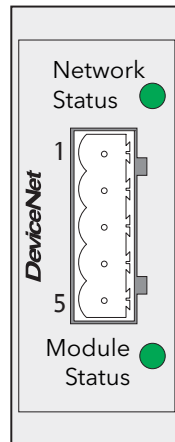

Figure 2.2.1h Modbus TCP (Ethernet 10baseT) pinout

Network status LED Indication	
LED state	Interpretation
Off	Off-line or no power
Steady green	On-line to 1 or more units
Flashing green	On-line - no connections
Steady red	Critical link failure
Flashing red	1 or more connections timed out

Module status LED Indication	
LED state	Interpretation
Off	No power
Steady green	Operating normally
Flashing green	Missing or incomplete configuration
Steady red	Unrecoverable fault(s)
Flashing red	Recoverable fault(s)



Pin	Function
1	V- (negative bus supply voltage)
2	CAN_L
3	Cable shield
4	CAN_H
5	V+ (positive bus supply voltage).

- Notes:
- See DeviceNet specification for power supply specification
 - During startup, an LED test is performed, satisfying the DeviceNet standard.

Figure 2.2.1i DeviceNet® connector pinout

OPERATION MODE LED INDICATION	
LED state	Interpretation
Off	Off line or no power
Steady green	On-line, data exchange
Flashing green	On-line, clear
Red single flash	Parametrisation error
Red double flash	PROFIBUS configuration error

STATUS LED INDICATION	
LED state	Interpretation
Off	No power or not initialised
Steady green	Initialised
Flashing green	Diagnostic event present
Steady red	Exception error

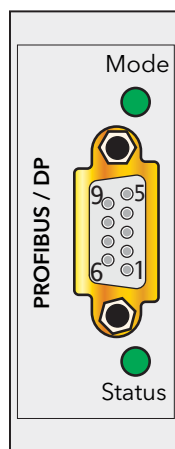

Pin	Function	Pin	Function
9	N/C	5	Isolated ground
8	A (Rx/D -/Tx/D -)	4	RTS
7	N/C	3	B (Rx/D+ / Tx/D+)
6	+5 V (See note 1)	2	N/C
		1	N/C

- Notes:
- Isolated 5 Volts for termination purposes. Any current drawn from this terminal affects the total power consumption.
 - The cable screen should be terminated to the connector housing.

Figure 2.2.1j Profibus connector pinout

2.2.1 Driver Module (Cont.)

COMMUNICATIONS PINOUTS (Cont.)

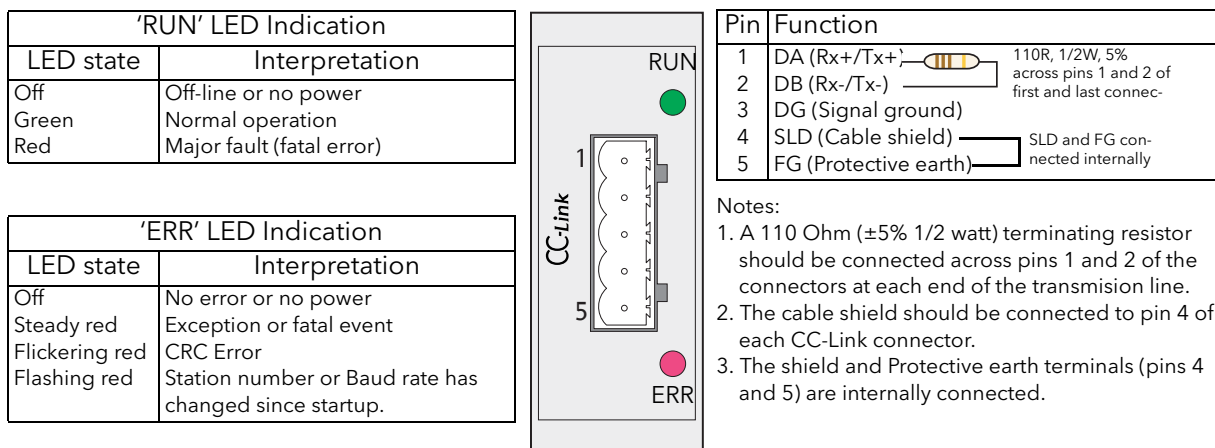

Figure 2.2.1k CC-Link connector pinout

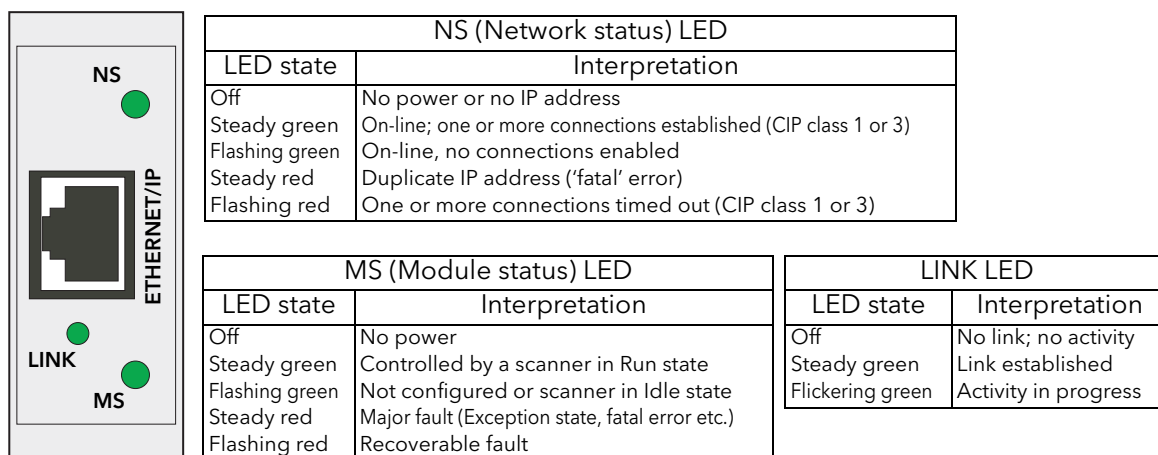

Figure 2.2.1l Ethernet I/P connector pinout

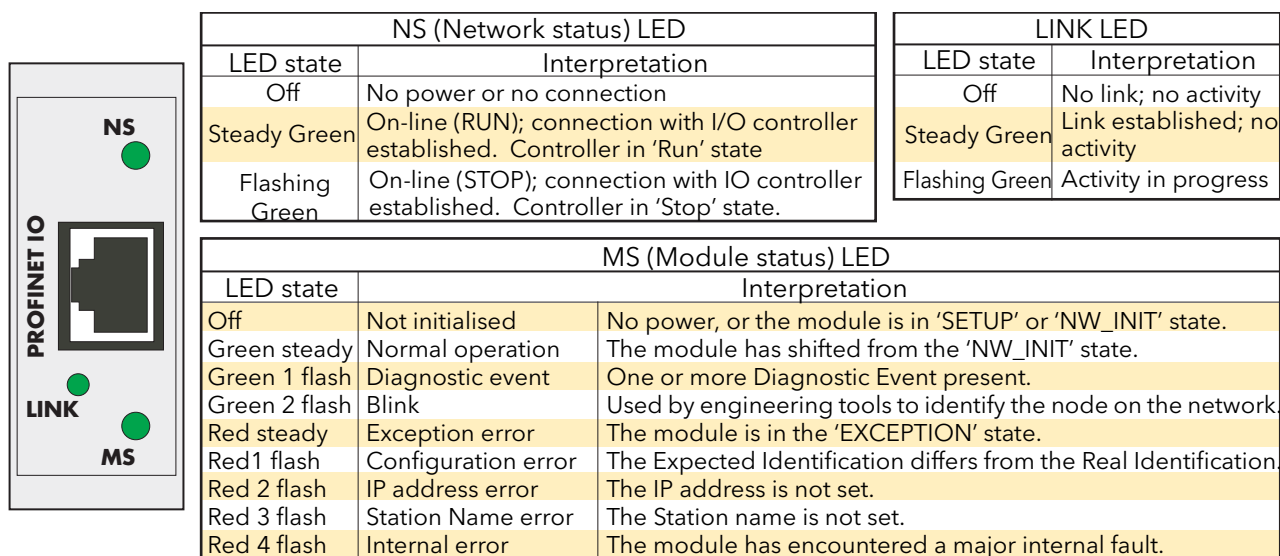
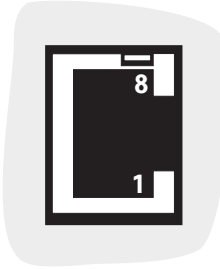

Figure 2.2.1m Profinet IO connector pinout

2.2.1 Driver Module (Cont.)

REMOTE PANEL CONNECTOR

Located on the underside of the driver module ([figure 2.2.1b](#)) this RJ45 connector supplies isolated 3-wire EIA485 outputs for an optional remote panel display unit. [Figure 2.2.1n](#) gives the pinout. See [section 6.6.2](#) for configuration details. Parity is set to 'None'. See also [Appendix A](#) for details of a suitable remote panel unit.



Pin	Definition
8	Reserved
7	Reserved
6	N/C
5	N/C
4	N/C
3	Isolated 0V
2	A
1	B

Internal connections:
Pin 1 to 5V via 100kΩ
Pin 2 to 0V via 100kΩ

Figure 2.2.1n Remote panel connector

2.2.2 Power modules

LINE/LOAD CABLES

Line power is routed through the top of the unit and load power emerges from the bottom of the unit.

CE: Wire conductor cross sections must comply with table 9 & 10 of IEC60947-1. Details of recommended cable sizes etc. are given in table 2.2.2, below.

UL: Wire conductor cross sections must comply NEC requirements. Used cables must be rated 75°C stranded copper only. Connection must be made by using listed lugs.

Safety earth wiring is discussed in section 2.2.1, above. Figures 2.2.2c to 2.2.2f show typical connection details.

Power terminals should be tightened according to the torque values defined in table 2.2.2. It is recommended to perform regular inspection of the power terminals tightening .

Max. load current	Terminal size	Minimum cable cross-section.	Recommended torque setting
50/100A	M8	35 mm ²	12.5 Nm (9.2 ft lb)
160A	M8	70 mm ²	12.5 Nm (9.2 ft lb)
250A	M10	120 mm ²	25 Nm (18.4 ft lb)
400A	M12	240 mm ²	28.8 Nm (21.2 ft lb)
500A	2 x M12	2 x 150 mm ²	30 Nm (22.1 ft lb)
630A	2 x M12	2 x 185 mm ²	30 Nm (22.1 ft lb)

Table 2.2.2 Line/Load termination details

RIBBON CABLE

The ribbon cable is daisy-chained from the Driver Module to the power modules.

Note: In order to maintain protection against damage due to electrostatic discharge, any ribbon cable which is chafed, scratched or otherwise damaged must be replaced.

EXTERNAL CURRENT FEEDBACK

If the option is fitted, a two-pin connector on the underside of the unit allows the connection of an external current transformer to measure the load current. The option also includes the Remote Voltage sensing input, described below. Both connectors have polarising devices fitted (description below) to prevent misconnection by the user.

The current transformer ratio must be such that its full scale output is 5 Amps. For example when measuring up to 400 Amps, a 400:5 ratio transformer should be chosen.

CAUTION

External feedback connections must be correctly phased (figure 2.2.2b) or the unit might switch to full conduction at start-up. See also Appendix B for more details about external feedback.

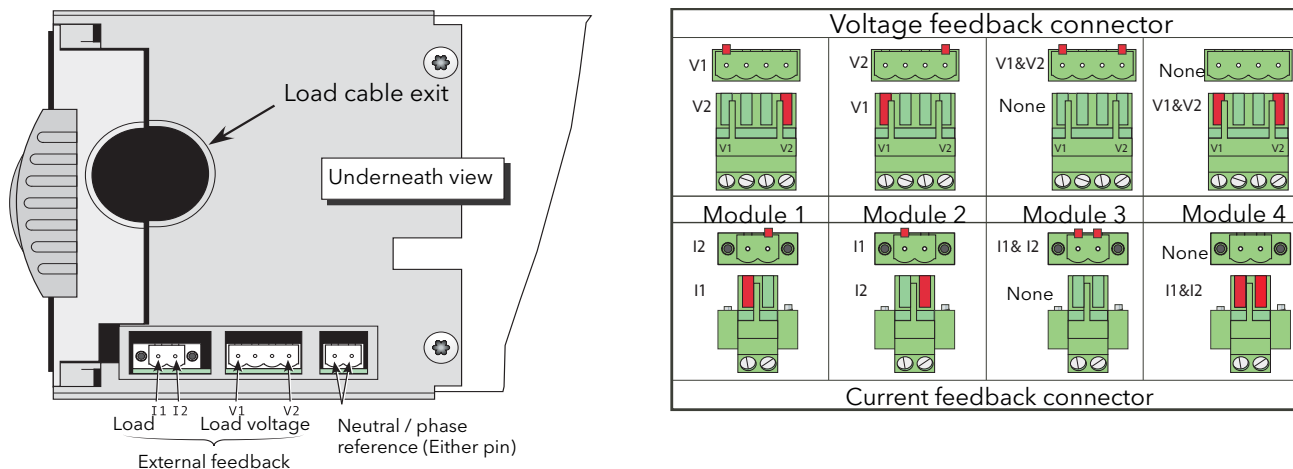

Figure 2.2.2a External feedback, and neutral/phase reference connectors

2.2.2 POWER MODULES (Cont.)

REMOTE VOLTAGE INPUT

WARNING

It must be ensured that the remote voltage sensing inputs (if fitted) are correctly fused. It is the responsibility of the user to add branch-circuit protection. Such branch-circuit must comply with applicable local regulations.

UL: The above mentioned branch-circuit protection is necessary for compliance with National Electric Code (NEC) requirements.

If the option is fitted, the two end pins of a four-pin connector (figure 2.2.2a) are used for terminating remote voltage sensing cable. It is recommended that each input be fitted with slow-blow fuse (figure 2.2.2b) of a lower current rating than that of the sensing cable harness. If the option is fitted, the Current Transformer input, described above, is also fitted.

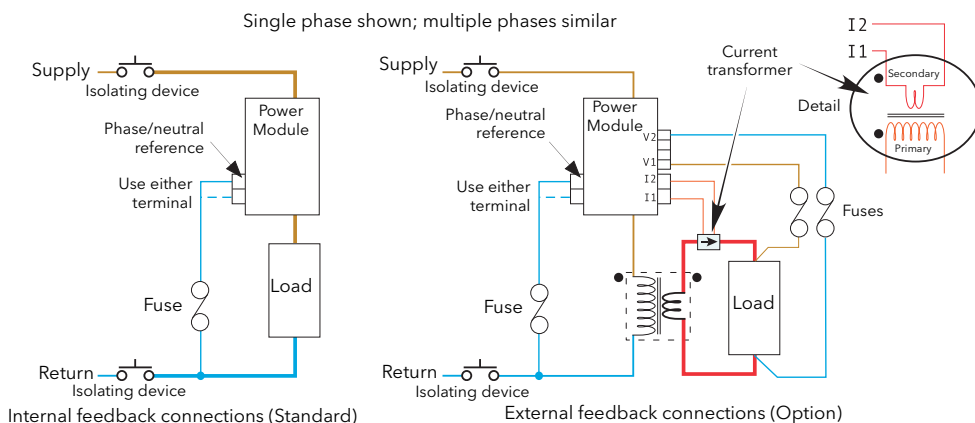

Figure 2.2.2b Fusing for remote voltage sensing input and neutral reference inputs

NEUTRAL/PHASE REFERENCE INPUT

WARNING

For 4S, 6D and two-leg configurations the reference input described below is connected to neutral or to a phase supply as appropriate see figure 2.2.2g for more details. For these configurations a fuse must be fitted in the reference input circuit. It is the responsibility of the user to add branch-circuit protection. Such branch-circuit must comply with applicable local regulations. UL: The above mentioned branch-circuit protection is necessary for compliance with National Electric Code (NEC) requirements.

CAUTION

1. For '4S' and single phase configurations, loss of the neutral supply causes the reference to be lost as well. For '6D' and 'two-leg' configurations, loss of the relevant phase supply also causes the loss of the reference.
2. The reference connection must be made before power is applied, and not disconnected until after power has been switched off.

In order to ensure correct firing for 4S, 6D and two-leg configurations, a connection to neutral or to the relevant phase must be made using the relevant two-pin connector on the underside of the unit (figure 2.2.2a). (Both pins are connected together internally, so either may be used.) This supplies a reference for voltage measurements within the unit. It is recommended that such inputs be fitted with a suitable slow-blow fuse, as shown in figure 2.2.2b above and figure 2.2.2g, below). The reference inputs for other configurations are not connected directly to the supply, and fusing is therefore not required.

The unit has been designed to detect the loss of any of the reference signals and to suspend firing should any of them 'fail'. Firing may not be correct during the detection period. As shown in the various figures, the reference connection is taken 'down-line' of any isolating device, so that should this device (e.g. contactor) 'trip out', then the controller will be able to detect the loss of reference signal and shut down appropriately.

2.2.2 POWER MODULES (Cont.)

NEUTRAL/PHASE REFERENCE INPUT (Cont.)

Polarising pins are fitted to the connectors as shown in the figure below.

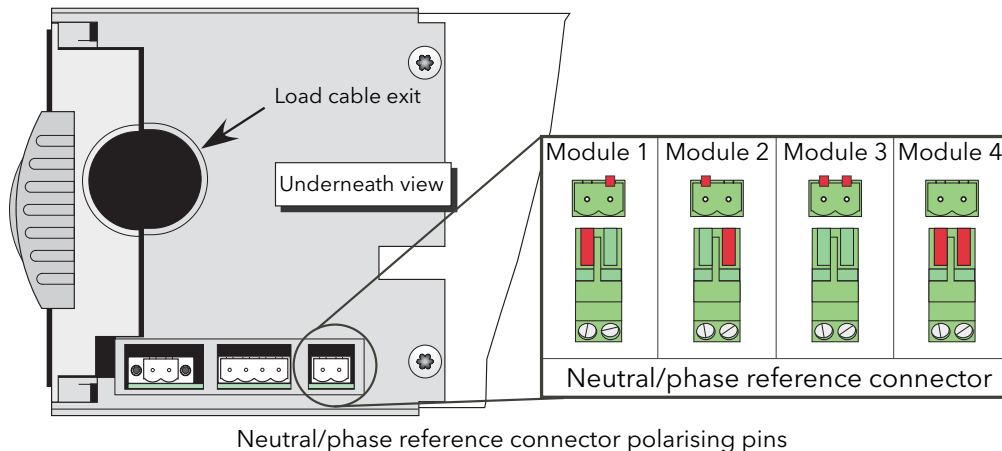

ACCESS TO LINE AND LOAD TERMINATIONS

WARNING

LETHAL VOLTAGES of up to 690 V ac appear at large areas of exposed metal when the doors to the power modules are open. It must be ensured by the user that the units are isolated from all hazardous voltages, and secured against accidental application of power, before the doors are opened. It is recommended that voltage checks are carried out within the unit (if wired), or at the supply and load cables before any work is started.

For 50A, 100A, 160A and 250A units, to remove the doors, insert a non-insulated screwdriver with a 5 mm flat blade into the slot near the top of the door, and gently lever downwards to disengage the catch, and pull the top of the door away from the unit. Once free, the door can be lifted off its pivots which are located at the bottom of the case.

For the 400A unit, the door is released by undoing the two fasteners near the top of the door and then pulling the top of the door away from the unit. Once free, the door can be lifted off its pivots which are located at the bottom of the case.

The 500A/630Amp module door is similar to the 400Amp module, but once released, the bottom of the door is pulled downwards to disengage it from its securing lugs, not lifted off, as described for the 400A module.

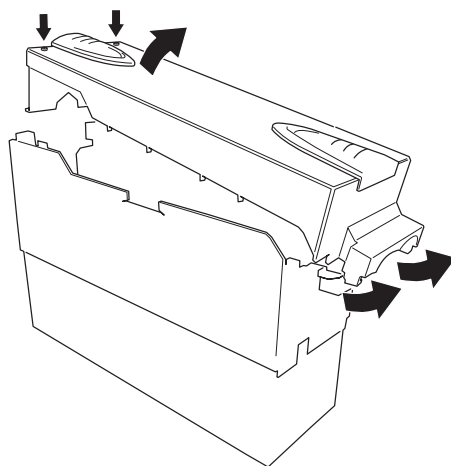

Door removal (500/630A units)

2.2.2 POWER MODULES (Cont.)

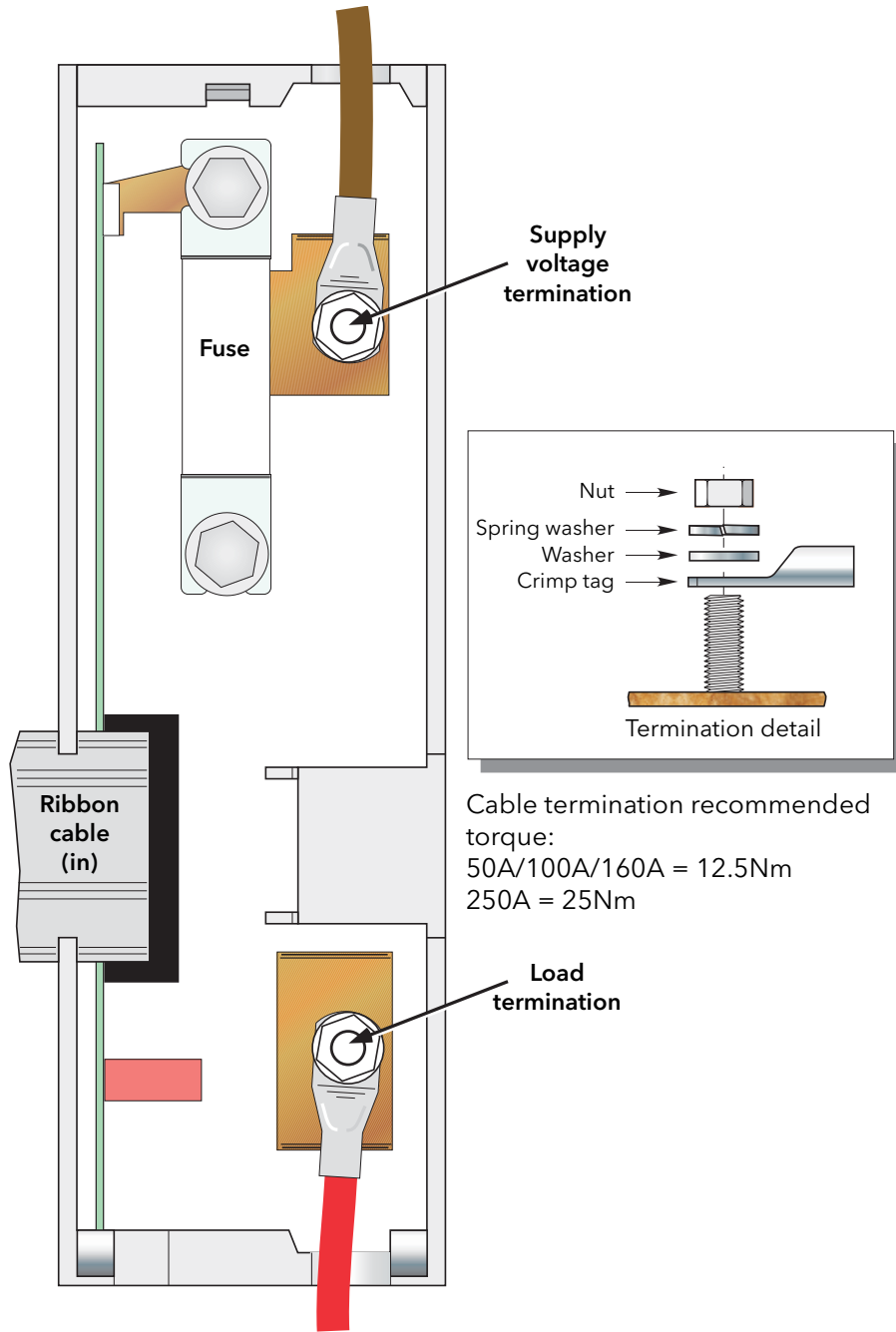

Figure 2.2.2c Line and load termination (50A, 100A and 160A units) (250A units similar)

2.2.2 POWER MODULES (Cont.)

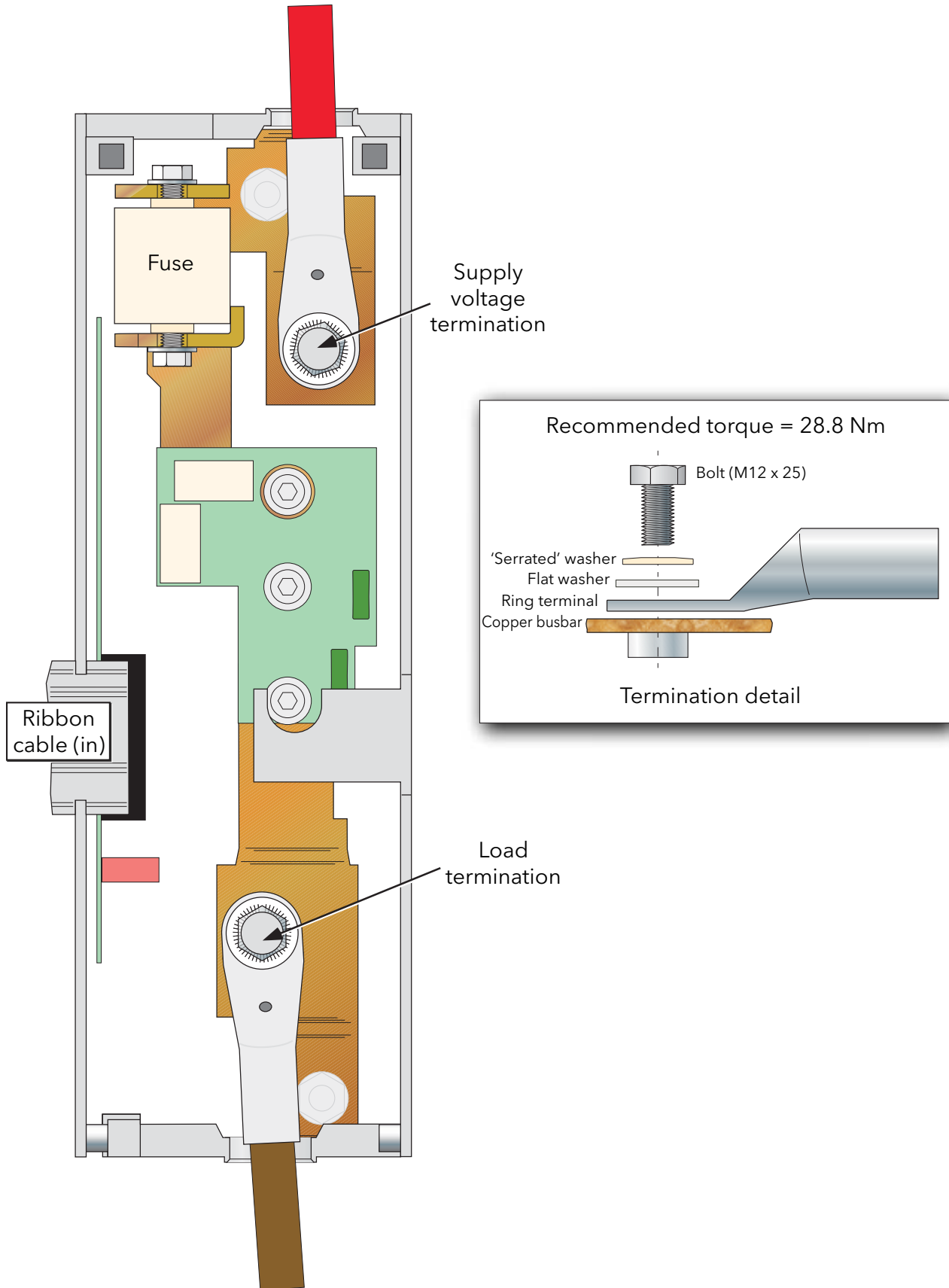

Figure 2.2.2d Line and Load termination (400A units)

2.2.2 POWER MODULES (Cont.)

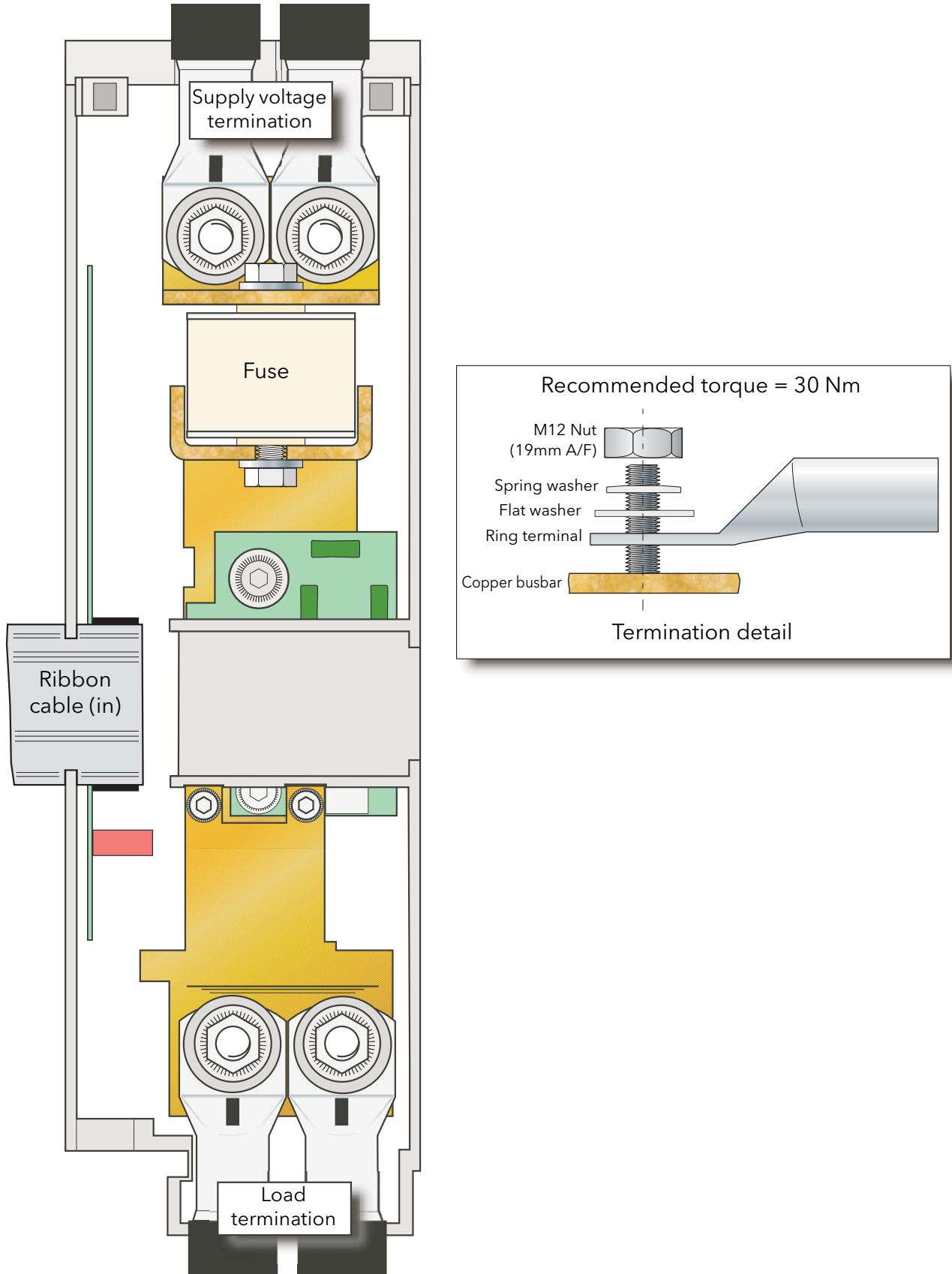

Figure 2.2.2e Line and Load termination (500A units) (630A units similar)

2.2.2 POWER MODULES (Cont.)

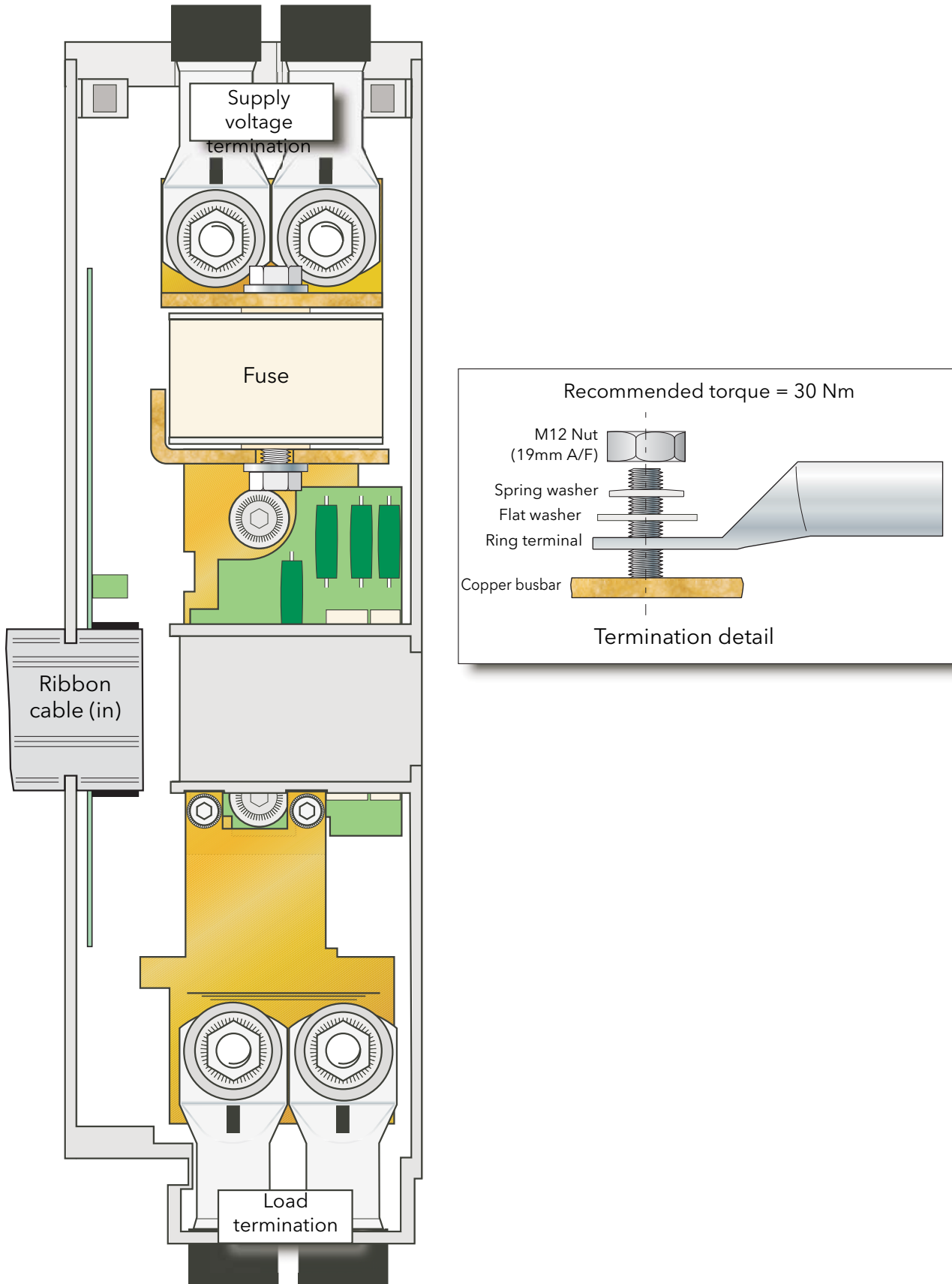

Figure 2.2.2f Line and Load termination (630A units)

2.2.2 POWER MODULES (Cont.)

The illustrations which make up figure 2.2.2g, below, show schematic and practical wiring arrangements for a number of common three-phase configurations. Earthing and driver module wiring are omitted for the sake of clarity. Fuses (where fitted) should have values compatible with the current carrying capacity of the associated wiring. Appendix B contains a discussion of external feedback.

CAUTION

1. Neutral/phase reference connections (if applicable) must be located between any isolating device and the relevant Power Module.
2. For single phase configurations, all Neutral reference connections must be individually fused.

Note: The figures below are intended only as theoretical examples. In order to comply with NEC requirements, branch circuit protection must be incorporated by the user, upstream of the equipment. Such protection is not shown in the figures below, for the sake of clarity. The installation, in its entirety, must comply with all applicable local safety and emissions regulations.

THREE-PHASE STAR CONFIGURATIONS

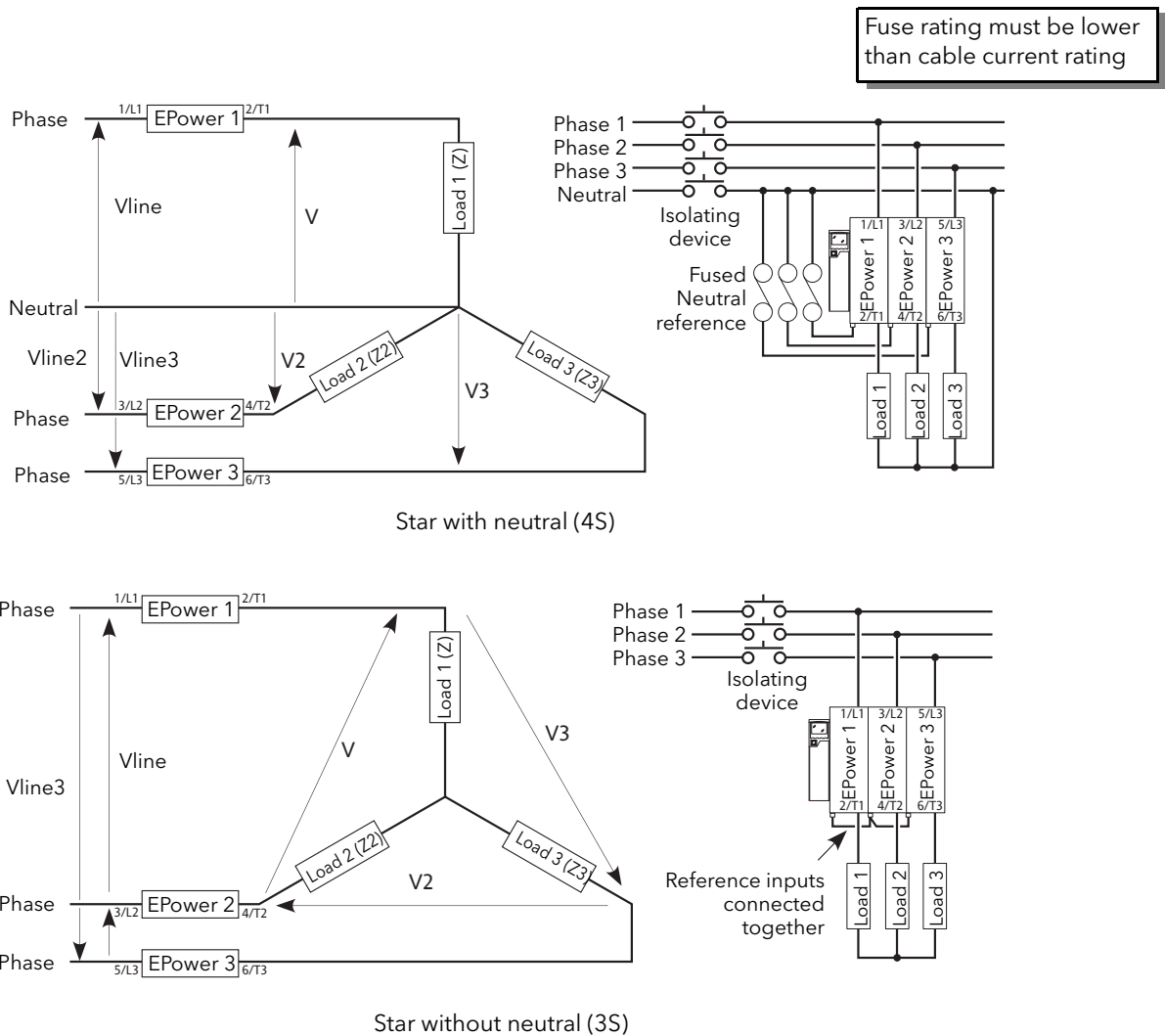

Figure 2.2.2g Typical wiring schemes (Star)

2.2.2 POWER MODULES (Cont.)

THREE-PHASE DELTA CONFIGURATIONS

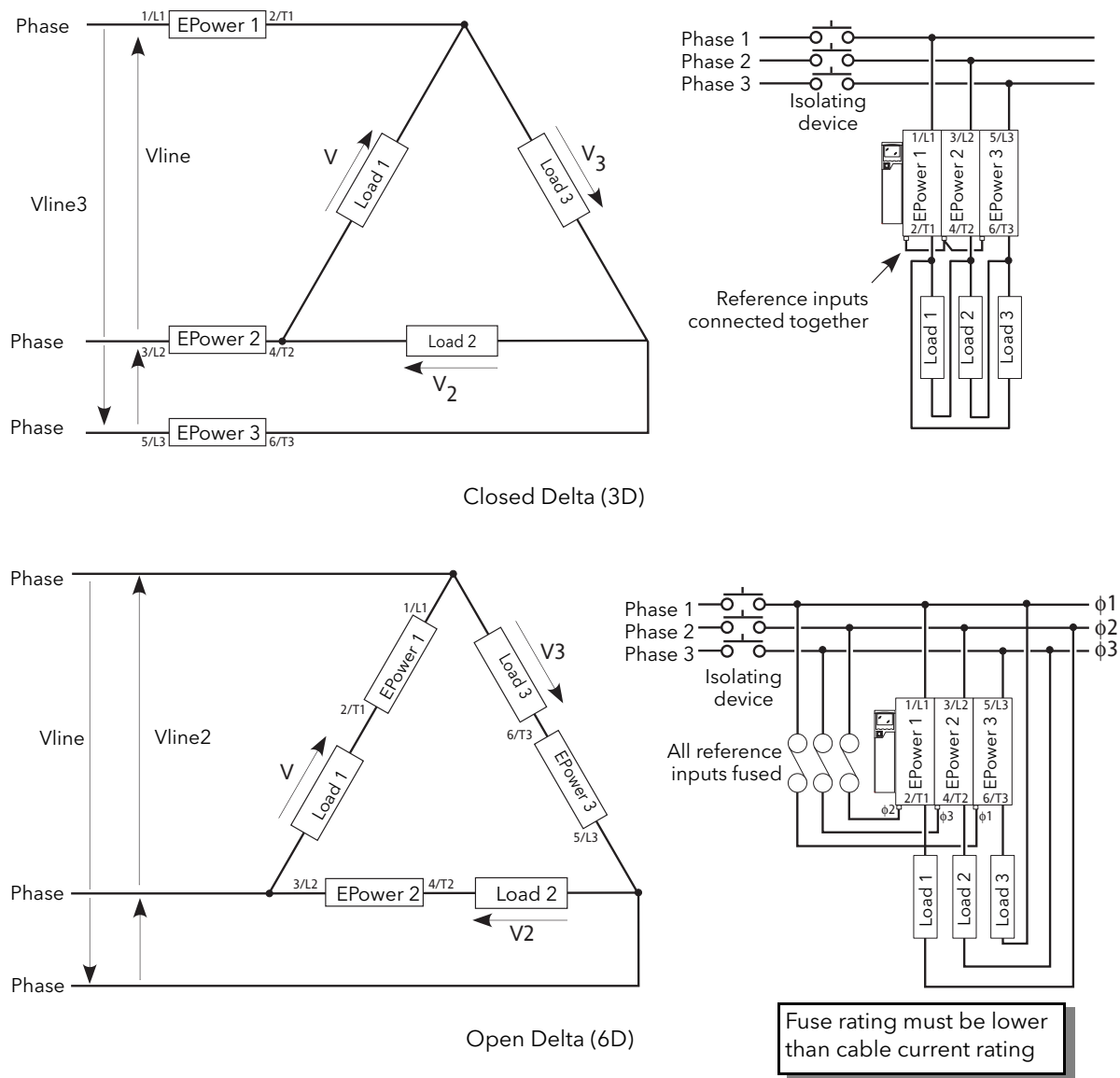

Figure 2.2.2g (Cont.) Typical wiring schemes (Delta)

CAUTION

Neutral/phase reference connections (if applicable) must be located between any isolating device and the relevant Power Module.

2.2.2 POWER MODULES (Cont.)

TWO-LEG CONFIGURATIONS

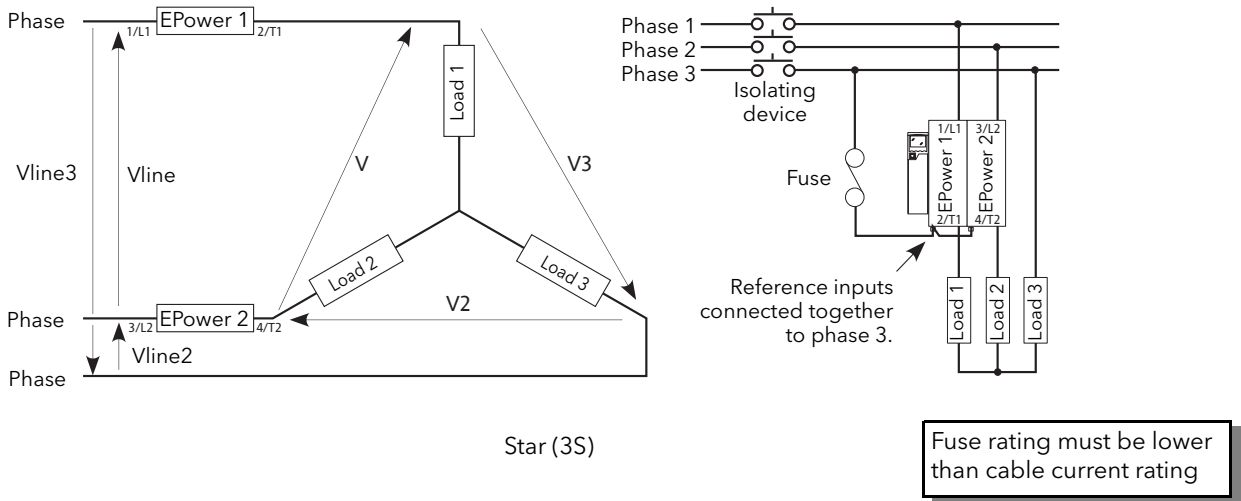

Star (3S)

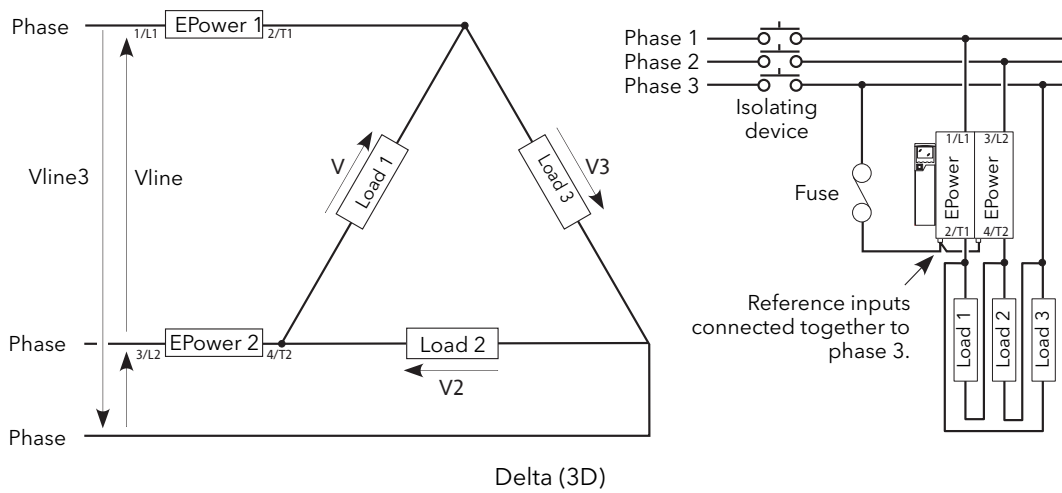

Delta (3D)

Figure 2.2.2g (Cont.) Typical wiring schemes (2-leg)

CAUTION

Neutral/phase reference connections (if applicable) must be located between any isolating device and the relevant Power Module.

2.2.2 POWER MODULES (Cont.)

THREE PHASE CONFIGURATIONS WITH EXTERNAL FEEDBACK

See for a discussion about external feedback, including more examples.

Note: The current transformer should be chosen such that its full-scale output is 5 amps.

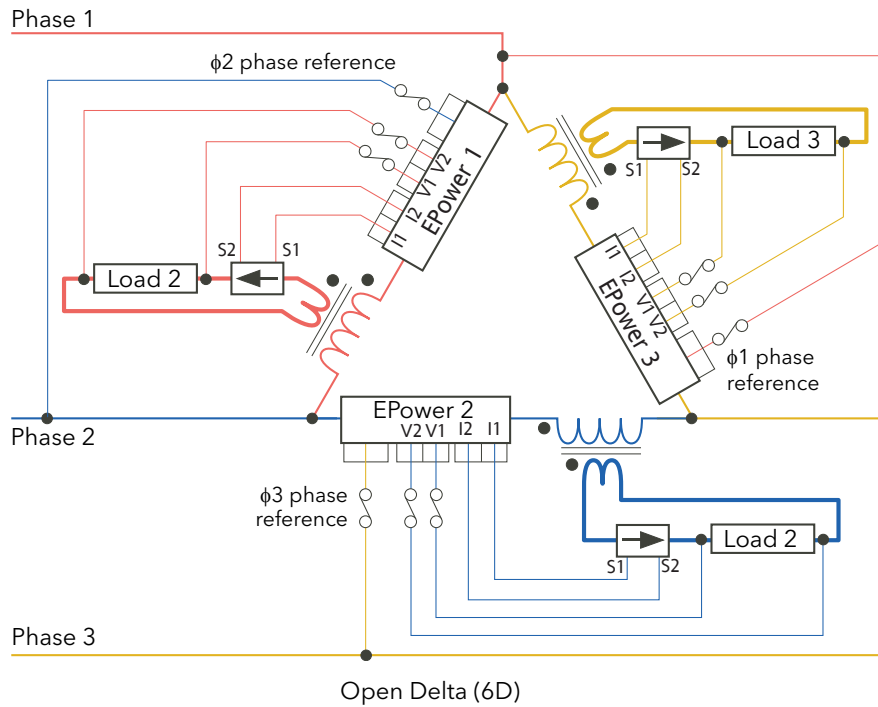
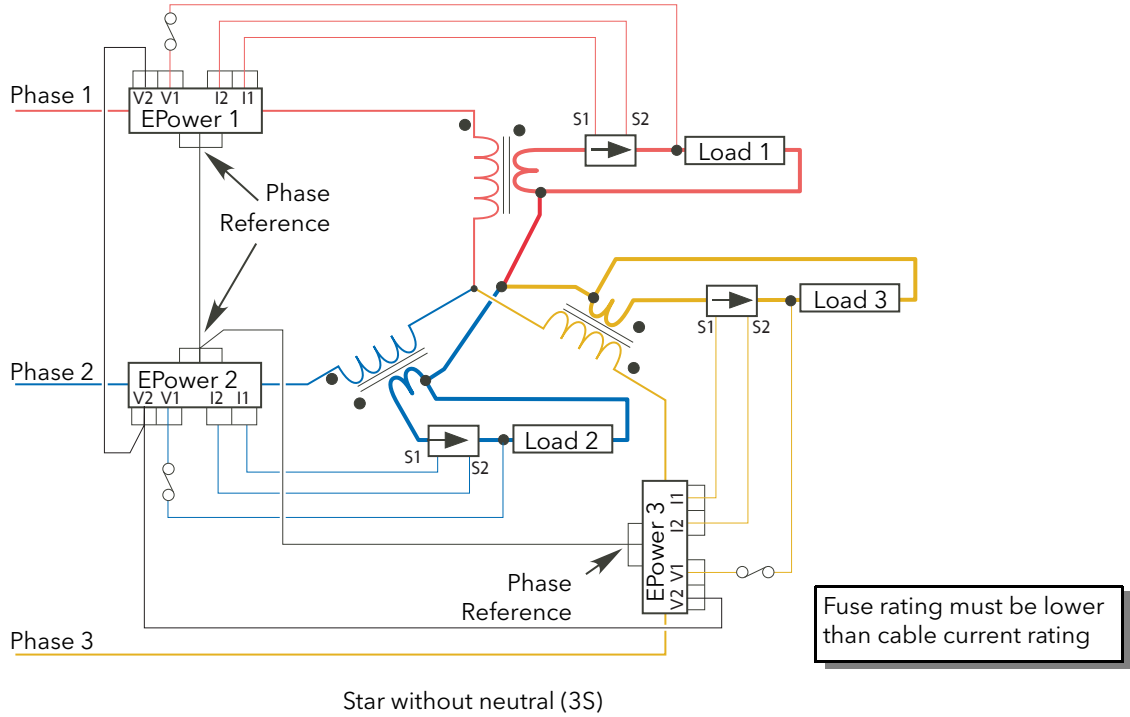

Figure 2.2.2g (cont.) Typical 3-phase external feedback wiring

2.2.2 POWER MODULES (Cont.)

THREE PHASE CONFIGURATIONS WITH EXTERNAL FEEDBACK (Cont.)

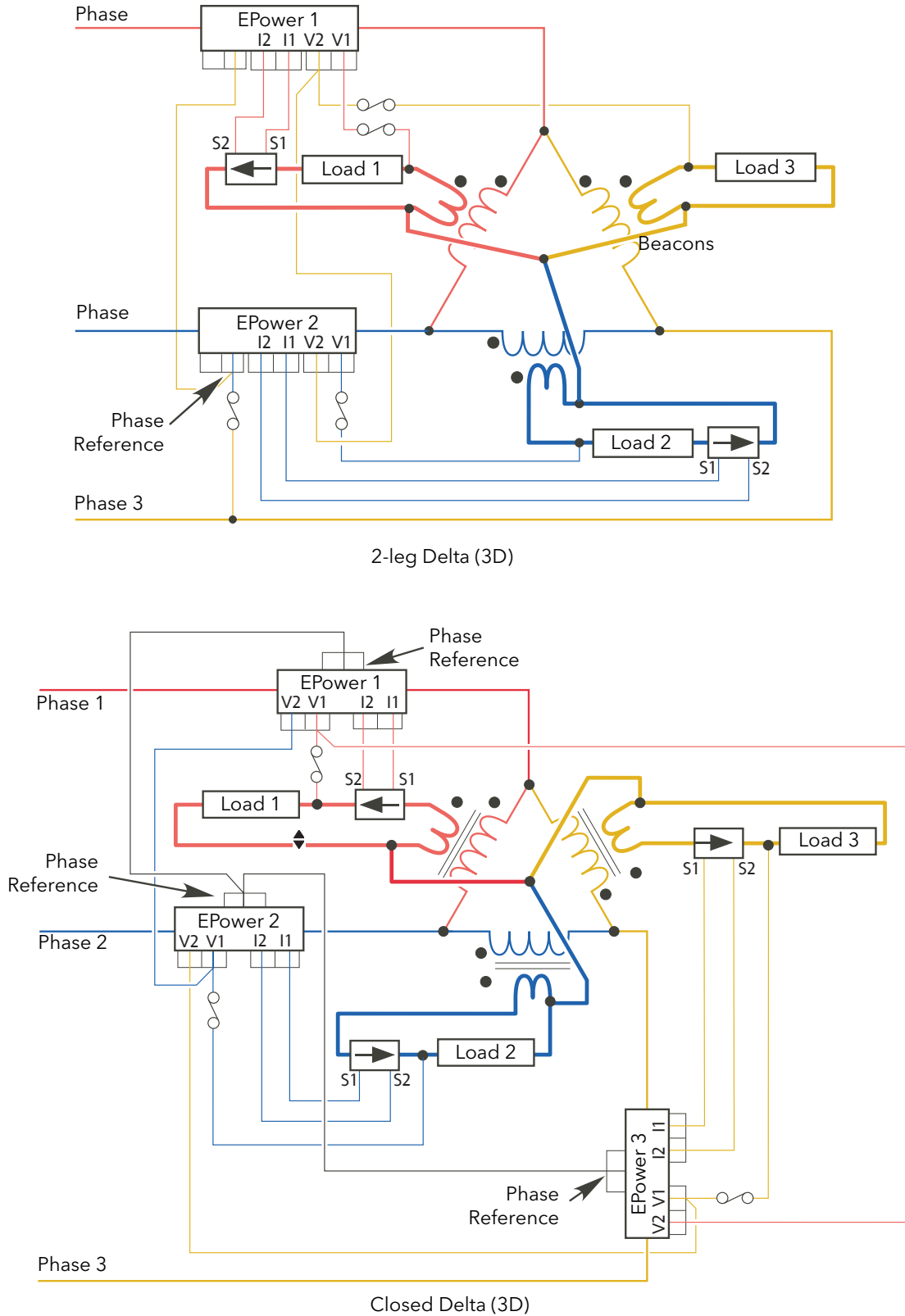

Figure 2.2.2g (cont.) Typical 3-phase external feedback wiring

3 OPERATOR INTERFACE

Located at the front of the Driver Module, the operator interface consists of a display, featuring four lines of up to 10 characters each, four push-button switches and three LED 'beacons'.



Figure 3 Operator interface

3.1 DISPLAY

As mentioned above, the display consists of four lines of characters, these characters being formed using a seven-high, by five-wide dot matrix. This display, together with the four pushbuttons allows full operation and configuration of the unit.

3.2 PUSHBUTTONS

The functions of the four pushbuttons below the display depend on whether the unit is in configuration mode or in operating mode:

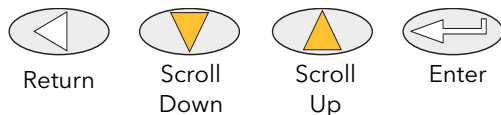

3.2.1 Configuration

Return	Generally, this button reverses the last operation of the 'Enter' button
Scroll down/up	Allows the user to scroll through the available menu items or values. The up/down arrow symbol appears against menu items that can be edited.
Enter	Goes to next menu item.

3.2.2 Operation

In operation, two pushbuttons may be operated simultaneously to carry out the following functions:

Scroll up + Scroll down	Acknowledge alarms
Scroll up + Enter	Toggle between 'Local' and 'Remote' operation.
Scroll down + Enter	PLF adjustment request

3.2.3 Menu item value selection

Menu items are scrolled through using the enter key. Editing of the item's value is carried out by scrolling through the available choices, using the up and down scroll keys. Once the desired value is displayed, it will become the selected value approximately two seconds after the final scroll key operation, this selection being indicated by a single off/on flash of the desired value.

3.3 BEACONS

There are three LED illuminated 'beacons' between the display area and the pushbuttons. For clarity, figure 3, above, shows the locations of these beacons in an enhanced way; on the real instrument, they are 'invisible' unless illuminated.



PWR	'Power'. Illuminated green whilst power is applied to the unit. The Beacon flashes if any of the associated power modules is not firing, or if the unit is in Standby (for any reason other than that the unit is in 'config' mode).
LOC	'Local'. Illuminated orange when setpoints are to be read from the operator interface or from PC/iTools.
ALM	'Alarm'. Illuminated red when one or more enabled alarms is active.

3.4 FRONT PANEL MESSAGES

A number of messages can appear at the display panel. These messages and their interpretations are listed below. See [section 10](#) for a more detailed description of some of these alarms.

3.4.1 Instrument events

Cold Start	The instrument has been cold-started.
Conf Entry	The instrument has been placed in configuration mode.
Conf Exit	The instrument has been taken out of configuration mode.
GlobalAck	A global acknowledgement of all safe latched alarms has been performed.
Power down	The instrument has restarted after a power down.
QS Entry	The Quick Start menu has been re-entered.
QS Exit	The Quick Start menu has been left.

3.4.2 Indication alarms

LimitAct	One or more limits are active in the control block
LoadOverl	An over current alarm has become active in one or more Network blocks.
LMoverSch	(Predictive Load Management over schedule). The actual power (Pr) is greater than the requested shed power value (Ps) (detected in the PLM block).
PrcValTfr	Process value transfer is active in one or more control blocks,

3.4.3 System alarms

FuseBlown	One or more thyristor protection fuses is ruptured.
MainsFreq	Mains Frequency is outside the acceptable range.
Missmains	One or more supply phases is missing.
NetwDip	One or more 'network dip' alarms has been detected.
OverTemp	One or more 'over temperature' alarms has been detected.
PMod24V	A power supply problem has been detected on the Driver Unit power board.

3.4.4 Process alarms

ChopOff	One or more 'Chop-off' alarm has been detected.
ClosedLp	One or more Control block 'Closed Loop' alarm has been detected.
InputBrk	An 'Input Break' alarm has been detected in one or more Analogue input blocks.
MainVFault	One or more 'Mains Voltage Fault' (over or under) has been detected.
OutFault	An 'Output short Circuit' alarm has been detected in one or more Analogue output blocks.
PLF	One or more 'Partial Load Failure' alarm has been detected.
PLU	One or more 'Partial Load Unbalance' alarm has been detected.
TLF	One or more 'Total Load failure' alarm has been detected.

3.4.5 Configuration errors

InvPAdata	(Invalid parameter database). The non-volatile parameter database has become corrupt and should not be relied upon.
InvWires	(Invalid wiring table). The non-volatile storage of user (soft) wiring has become corrupt and should not be relied upon.

3.4.6 Standby errors

PwrModRev	(Power Module revision). One or more power units has an invalid revision number, or its revision level is not compatible with the firmware version of the driver module.
HWDiffers	The fitted hardware does not match the instrument configuration.
ErrDSP	Error(s) reported by the Digital Signal Processor, during the instrument's start-up self test procedure.
Pwr1Ribbon	A fault was detected in the power module 1 ribbon cable during the instrument's start-up self test procedure.
Pwr2(3)(4)Ribbon	As above but for power module 2, 3 or 4.

3.4.7 Power module errors

Ph1(2)(3)(4)ComErr	The phase 1, 2, 3 or 4 power module has attempted to communicate with the driver module, and either the driver module or the power module (or both) has failed to 'understand' the communication commands/responses.
Ph1ComTout	(Comms timeout). The phase 1, 2, 3 or 4 power module indicated that it wished to report a fault to the driver module but the communications transaction was not completed.
Ph2(3)(4)ComTout	As for phase 1, above but for phase 2, 3 or 4.
Pwr1EEProm	Header information in power module 1 non-volatile memory was found to be invalid at the instrument's start-up self test procedure.
Pwr2(3)(4)EEProm	As for power module 1, above but for power module 2, 3 or 4.
Ph1(2)(3)(4)Wdog	The phase 1, 2, 3 or 4 power module microprocessor has detected that its watchdog timer has timed out. A reset has been performed and this has caused the power module to report the fault.

3.4.8 General errors

Watchdog	The driver module's microprocessor has detected that its watchdog timer has timed out, and has therefore performed a reset, causing the instrument to restart.
LogFault	The event log could not be restored at start-up.
PWR1(2)(3)(4)cal	The calibration data stored in the non-volatile memory of power module 1, 2, 3 or 4 is invalid, and the default calibration will be used instead.

3.4.9 Reset errors

InvRamCsum	(Invalid RAM checksum). Internal fault
DSPnoRSP	(DSP no response). Internal fault.
DSP Wdog	(DSP task watchdog). Internal fault.

3.4.10 Fatal errors

FuseConfig	The driver module's internal fuses are incorrectly configured.
ErrRestart	An error has occurred that requires the instrument to be restarted.

4 QUICKSTART

At first switch-on, the Driver Module enters the 'QuickStart' menu which allows the user to configure the major parameters without having to enter the full configuration menu structure of the unit. Figure 4 shows an overview of a typical Quickstart menu. The actual displayed menu items will vary according to the number of options fitted.

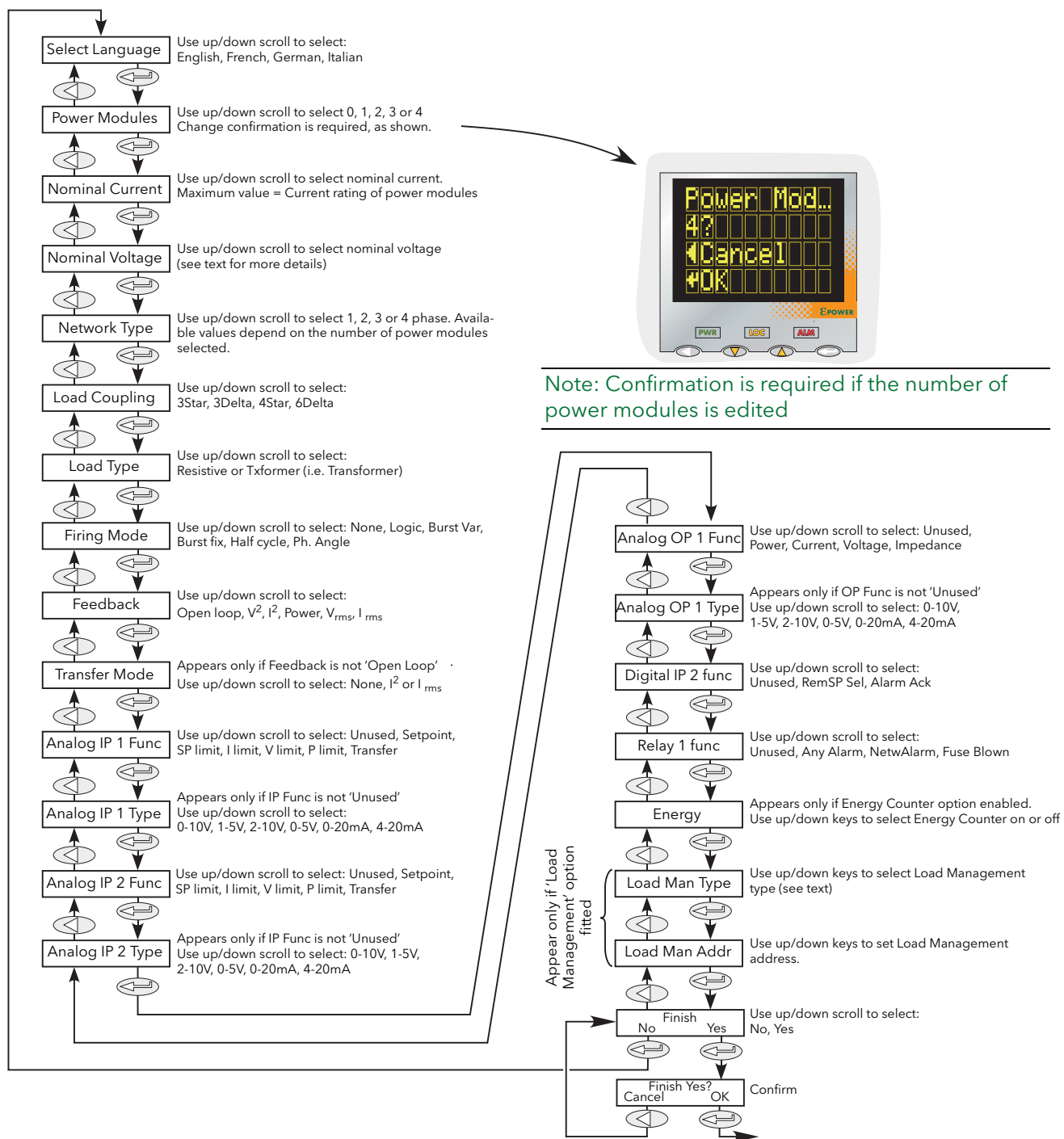

Figure 4 Typical Quickstart menu

4 QUICKSTART MENU (Cont.)

Notes:

1. If the unit has been fully configured at the factory, the Quickstart menu will be skipped, and the unit will go into operation mode at first switch on.
2. Once quit, the Quickstart menu can be returned to at any time from the Engineer or Configuration menus (described later in this document) by holding the 'Return' key operated for approximately two seconds. If values have been changed 'outside' the Quickstart menu, these values are displayed as '---' on re-entry to the Quickstart menu.

4.1 QUICKSTART MENU PARAMETERS

Language	Initially, English, French, German and Italian may be selected. Other languages may be added during the lifetime of this issue of the manual. Once confirmed (single blink after approximately two seconds), then all further displays appear in the selected language.
Power Modules	Select the number of power modules between 0 and 4 that the driver module is to control. The number of phases offered (in Network type, below) depends on this value. Editing this value causes a confirmation screen to appear. 'OK' confirms the change.
Nominal Current	A value, normally between the maximum current the Power Modules are each able safely to sustain and a quarter of this value. Thus, for a 400 Amp unit, any nominal current value between 100 and 400 may be selected. (Lower values are not recommended as in such cases, the resulting accuracy and linearity are not guaranteed to be within specification.)
Nominal Voltage	A value between the maximum permanent supply voltage (+10%) to the modules, and a quarter of this value. Available values are 100, 110, 115, 120, 127, 200, 208, 220, 230, 240, 277, 380, 400, 415, 440, 460, 480, 500, 575 and 600.
Network Type	Allows the user to select 1, 2 or 3 phases depending on the selection made in 'Power Modules', above. The table shows the choices.
Load Coupling	For Network Type entries other than single phase: 2 phase: allows 3 Star or 3 Delta to be selected 3 phase: allows 3 Star, 3 Delta, 4 Star or 6 Delta to be selected.
Load Type	Allows 'Resistive' or 'Txformer' (transformer) to be selected as the type of load. If Txformer is selected, this modifies the start up procedure to limit the inrush current.
Firing Mode	Select from 'Logic', 'BurstVar', 'BurstFix', 'HalfCycle' or 'Ph.Angle'.
Feedback	Allows the user to choose open Loop, V^2 , I^2 , Power, V_{rms} or I_{rms} .
Transfer Mode	If Feedback is set to any value other than 'Open Loop', 'None', ' I^2 ' or ' I_{rms} ' can be selected as transfer mode. If Feedback is set to 'Open Loop', the Transfer Mode page does not appear.
Analog IP1 Func	Selects the Analogue input 1 function as 'Unused', 'Setpoint', 'SP limit', 'I limit', 'V limit', 'P limit' (power limit) or 'Transfer'. Allows (for example) a potentiometer to be connected to Analogue input 1, so that setpoint can be dynamically varied.
Analog IP 1 Type	Allows the user to select the analogue input type as 0 to 10V, 1 to 5V, 2 to 10V, 0 to 5V, 0 to 20mA, 4 to 20mA. This menu item does not appear if 'Unused' is selected in IP1 Func (above).
Analog IP 2 Func	As for Analog IP 1 Func, except 'Setpoint' does not appear if it has already been selected as Analog IP 1 type
Analog IP 2 Type	As for Analog IP 1 type
Analog OP 1 Func	Allows the user to select 'Unused', 'Power', 'Current', 'Voltage' or 'Impedance' to be selected as output type.
Analog OP 1 Type	Allows the user to select the analogue output type as 0 to 10V, 1 to 5V, 2 to 10V, 0 to 5V, 0 to 20mA, 4 to 20mA. This menu item does not appear if 'Unused' is selected in OP1 Func (above).
Digital IP2 Func	Select Digital input 2 function as 'Unused', 'RemSP Sel' (Remote setpoint select) or 'Alarm Ack'
Relay 1 Func	Allows the function of Relay 1 to be set as 'Unused', 'Any Alarm', 'NetwAlarm', or 'Fuse Blown'.

Power Modules	Network Type
0	0
1	1
2	1 or 2
3	1 or 3
4	1 or 2

4.1 QUICKSTART PARAMETERS (Cont.)

Relay 1 Func	Allows the function of Relay 1 to be set as 'Unused', 'Any Alarm', 'NetwAlarm', or 'Fuse Blown'.
Energy	Appears only if one or more Energy counter blocks (section 6.10) are included in the configuration. Allows energy counters to be enabled and disabled.
Load Man Type	Appears only if the Predictive Load Management option is fitted. Allows the user to select one of LMNo (disabled), Sharing, IncrT1, IncrT2, RotIncr, Distrib, DistIncr, RotDisInc. See section 9 for more details.
Load Man Address	Appears only if the Predictive Load Management option is fitted. Allows the user to enter a Predictive Load Management address.
Finish	Select 'No' to return to the top of the Quickstart menu, or 'Yes' to enter the User menu, after confirmation. (See also note below.)

Note: The 'Finish' item might not appear if an inconsistent or incomplete configuration is entered. In such a case, the 'Language' selection page at the top of the menu re-appears.

4.2 SOME DEFINITIONS

4.2.1 Firing modes

LOGIC

Power switches on, two or three zero crossings of the supply voltage after the logic input switches on. Power switches off two or three zero crossings of current after the logic input switches off. For resistive loads, voltage and current cross zero simultaneously. With inductive loads, a phase difference exists between the voltage and current, meaning that they cross zero at different times. The size of the phase difference increases with increasing inductance.

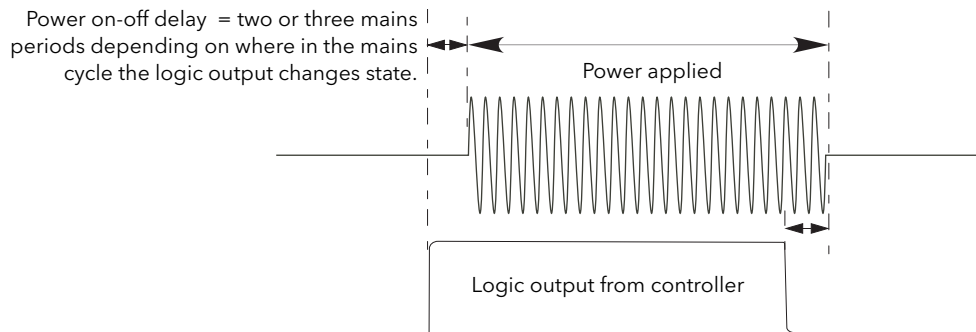

Figure 4.2.1a Logic firing mode

BURST FIXED FIRING

This means that there is a fixed 'cycle time' equal to an integer number of supply voltage cycles as set up in the Modulator menu. Power is controlled by varying the ratio between the on period and the off period within this cycle time (figure 4.2.1b).

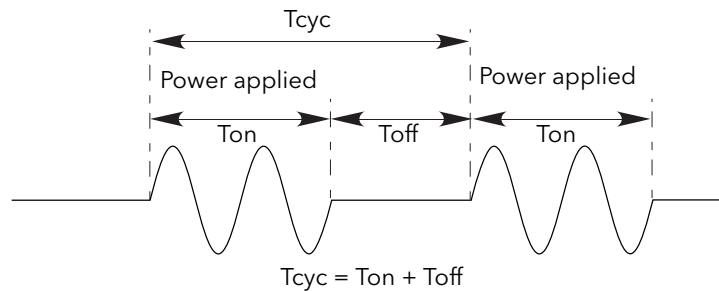

Figure 4.2.1b Burst Fixed mode

4.2.1 FIRING MODES (Cont.)

BURST VARIABLE FIRING

Burst Firing Variable is the preferred mode for temperature control. Between 0 and 50% of setpoint, the on time is the 'Min on' time set in the modulator menu and the off time is varied to achieve control. Between 50% and 100%, the off time is the value set for 'Min on' and power is controlled by varying the number of on cycles.

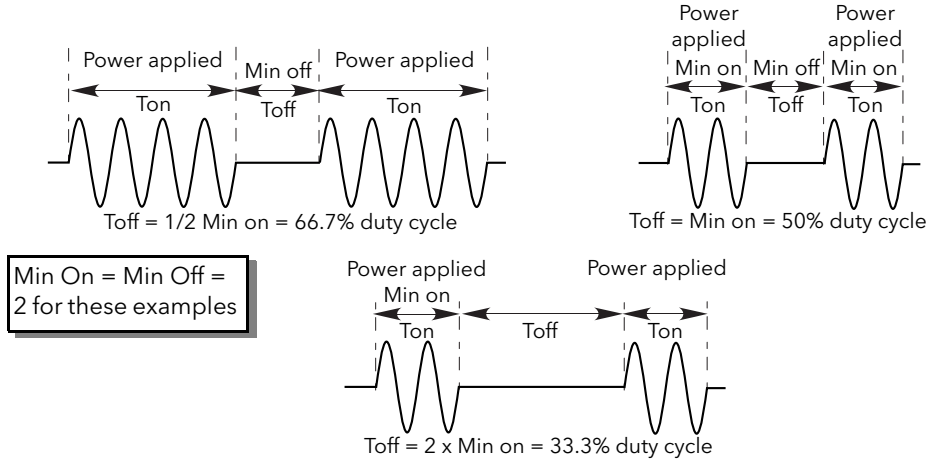

Figure 4.2.1c Burst variable firing

PHASE ANGLE CONTROL

This mode of firing controls power by varying the amount of each cycle which is applied to the load, by switching the controlling thyristor on part-way through the cycle. Figure 4.2.1d shows an example for 50% power.

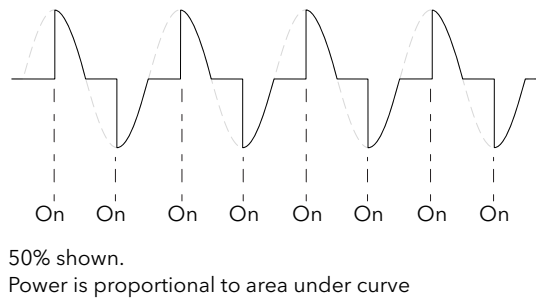

Figure 4.2.1d Phase angle mode

HALF CYCLE MODE

Burst mode firing with a single firing (or non-firing) cycle is known as 'Single cycle' mode. In order to reduce power fluctuations during firing time, Intelligent half-cycle mode uses half cycles as firing/non-firing periods. Positive and negative going cycles are evened out, to ensure that no dc component arises. The following examples describe half-cycle mode for 50%, 33% and 66% duty cycles.

50% DUTY CYCLE

The firing and non-firing time corresponds to a single supply cycle (figure 4.2.1e).

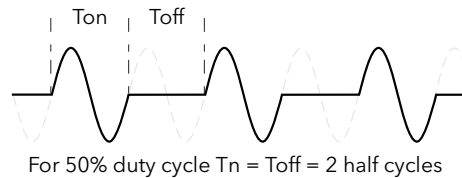
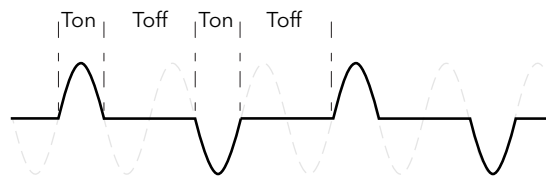

Figure 4.2.1e Half cycle mode: 50% duty cycle

4.2.1 FIRING MODES (Cont.)

33% DUTY CYCLE

For duty cycles less than 50%, the firing time is one half-cycle. For a 33% duty cycle, firing time is one half cycle; the non-firing time is two half-cycles (figure 4.2.1f).



For 33% duty cycle

Ton = 1 half cycle; Toff = 2 half cycles

Figure 4.2.1f Half cycle mode: 33% duty cycle

66% DUTY CYCLE

For duty cycles of greater than 50%, the non-firing time is one half-cycle. For 66% duty cycle, the firing time is two half cycles; the non-firing time is one half cycle (figure 4.2.1g).

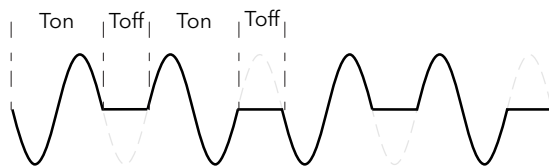

For 66% duty cycle

Ton = 2 half cycles; Toff = 1 half cycle

Figure 4.2.1g Half cycle mode: 66% duty cycle

4.2.2 Feedback type

All feedback types (except 'Open Loop') are based on real-time measurement of electrical parameters that are normalised to their equivalent Nominal values. Thus V_{RMS} is normalised to Nominal Voltage; V^2 is normalised to the square of Nominal Voltage and 'P' is normalised to the product of Nominal Voltage and Nominal Current.

V^2	Feedback is directly proportional to the square of the RMS voltage measured across the load. For two- or three-phase systems, feedback is proportional to the average of the squares of the individual phase-to-phase or phase-to-Neutral RMS voltage across each load.
Power	Feedback is directly proportional to the total true power delivered to the load network.
I^2	Feedback is directly proportional to the square of the RMS current through the load. For two- or three-phase systems, feedback is proportional to the average of the squares of the individual RMS load currents.
V_{rms}	Feedback is directly proportional to the RMS voltage measured across the load or, for multi-phase systems, to the average of the individual phase-to-phase or phase-to-neutral RMS load voltages.
I_{rms}	Feedback is directly proportional to the RMS current through the load or, for multi-phase systems, to the average of the individual RMS load currents.
Open loop	No measurement feedback. The thyristor firing angle in Phase angle mode, or the duty cycle in burst-firing mode, are proportional to the setpoint.

4.2.3 Transfer Mode

The control system can use automatic transfer of certain feedback parameters. For example with loads with very low cold resistance, I^2 feedback should be used to limit inrush current, but once the load has started to warm up, Power feedback should be used; the control program can be configured to change feedback mode automatically.

The Transfer mode can be selected as I^2 to P or I_{rms} to P as appropriate to the type of load being controlled

None	No feedback parameter transfer to the control program
I^2	Selects transfer mode: I^2 to the selected Feedback Mode (above).
I_{rms}	Selects transfer mode: I_{RMS} to the selected Feedback Mode (above).

4.2.4 Limitation features

In order, for example, to prevent potentially damaging inrush currents, it is possible to set a value for power or Current squared which is not to be exceeded. This limiting is implemented using phase angle reduction, duty cycle reduction or 'chop off', depending on the type of control (e.g. phase angle, burst firing). For loads exhibiting a low impedance at low temperatures but a higher impedance at working temperature, the current drawn reduces as the load warms, and limiting gradually becomes unnecessary.

[Section 6.7.3](#) describes the configuration parameters which allow the user to enter a Process Variable (PV) and a setpoint (SP) for each phase, where the PV is the value to be limited (e.g. I^2) and the SP is the value that the PV must not exceed.

FIRING ANGLE LIMITING

For phase angle control, limiting is achieved by reducing the firing angle on each half mains cycle such that the limit value of the relevant parameter is not exceeded. As limiting is reduced so the phase angle tends to its target value.

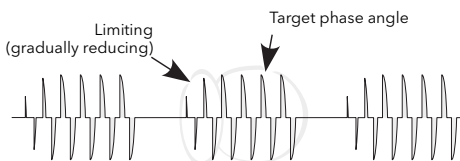

DUTY CYCLE LIMITING

For Burst Firing only, limiting reduces the 'On' state of the burst firing driving the load. Load current, voltage and active power are calculated over the period of each ($T_{on} + T_{off}$) period.

CAUTION

When applied to load current, duty cycle limiting does not limit the peak current value, and under some circumstances this may allow an overheating hazard in the load and/or Power Module to develop.

CHOP OFF

This is a limiting technique which detects an over-current alarm state and stops further thyristor firing for the duration of that alarm state. All the relevant parameters are to be found in the [Network Setup menu](#) ([section 6.20.2](#)).

There are two alarms which may trigger Chop Off, as follows:

1. The alarm is active when ChopOff1Threshold is exceeded for more than five seconds. This threshold can be set to any value between 100% and 150% inclusive, of the unit's nominal current ($I_{Nominal}$).
2. The alarm is active if ChopOff2Threshold is exceeded more than a specified number of times (Number Chop Off) within a specified time period (Window Chop Off). ChopOff2Threshold is adjustable between 100% and 350% inclusive, of $I_{Nominal}$; Number Chop Off can be selected to any value between 1 and 16 inclusive; Window Chop Off can be set to any value between 1 and 65535 seconds (approximately 18 hours 12 mins.).

Each time the threshold is exceeded, the unit stops firing, raises a chop off condition alarm, then after 100ms, restarts using an up-going safety ramp. The condition alarm is cleared if the unit successfully restarts. If the alarm is raised more than the specified number of times within the specified window, then the Chop Off alarm is set and the unit stops firing. Firing is not resumed until the operator acknowledges the Chop Off alarm.

5 OPERATOR MENU

At power up or after quitting the Quickstart menu, the unit initialises itself (figure 5) and then enters the first summary page of the Operator menu (figure 5.2).



Figure 5 Initialisation screens

Note: If any faults are detected during initialisation (e.g. supply voltage missing), then error messages appear on the display screen. The up and down arrow keys must be operated simultaneously to acknowledge each alarm in turn, before any further operations can take place.

5.1 SUMMARY PAGES

Each summary page displays the voltage, current and power status described below calculated over the mains period when in Phase Angle mode or over the Modulation Period when in Burst Mode. The user may also edit the local setpoint from the summary pages. Where more than one, single phase unit is being driven, the parameter names have a numeric suffix (e.g. V2) to indicate which phase is being displayed. The enter key can be used to scroll through the available phases.

The Return key can be operated briefly to access the top level operator menu, which contains all summary pages and Alarm and Event Log entries. (Operation of the Return key for an extended interval calls the Access page - see [section 6.3](#))

Notes:

1. A suffix 'n' below represents the number of the network currently being displayed.
2. 'LSP' is replaced in the display by 'RSP' for remote working.

5.1.1 Single phase summary page

Vn	The RMS load voltage measurement for network 'n'.
In	The RMS load current measurement for network 'n'.
Pn	The true power delivered to network 'n'.
LSPn	The local setpoint value for network 'n' - see also Note 2 above.

5.1.2 Two or three phase summary page

Vavg	The average RMS load voltage over all three loads.
Iavg	The average RMS load current over all three loads.
P	The true power delivered to the load network.
LSP	The local setpoint value - see also Note 2 above.

5.1.3 Two by two phase summary page

This is a mode of operation whereby a single four-power-module unit can control two independent, three-phase networks.

Vavn	The RMS load voltage averaged over all three loads for network 'n'.
Iavn	The RMS load current averaged over all three loads for network 'n'.
Pn	The true power delivered to load network 'n'.
LSPn	The local setpoint value for network 'n' - see also Note 2 above.

5.2 TOP LEVEL OPERATOR (USER) MENU

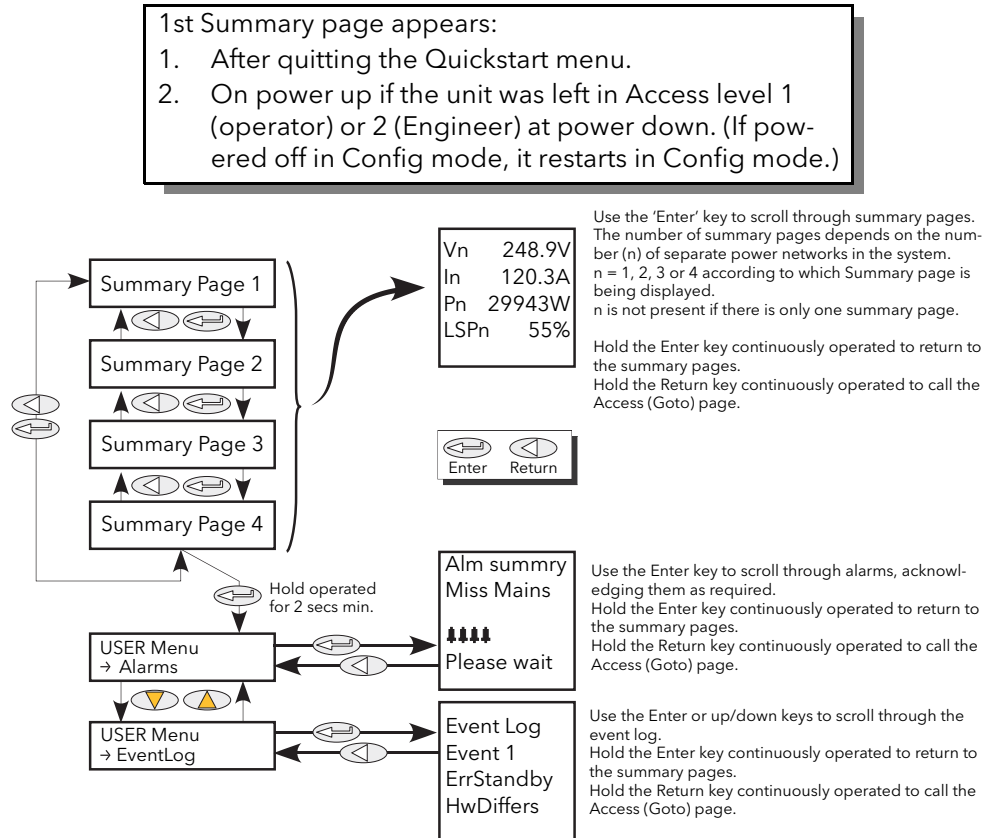

Figure 5.2 User menu overview

Note: The summary page is displayed at switch on only if the unit has been configured, either via the Quickstart menu, or at the factory. Otherwise, at first switch on, the Quickstart menu is entered.

Summary pages are discussed in section 5.1, above.

5.2.1 Alarm Summary pages

This page contains a list of currently active alarms, together with a group of four flashing bell symbols if the alarm is unacknowledged. The 'Enter' key is used to scroll through the list, and the up/down arrow keys are operated, simultaneously, to acknowledge each alarm, as required.

5.2.2 Event Log

This is a list of up to 40 event items where Event 1 is the latest. As shown in the figure below, Event number, Event Type and Actual Event (known as 'Event ID') appear on the screen.

Event Types and Event IDs are given in table 5.2.2.

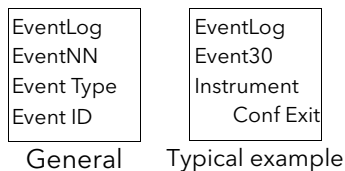

5.2.2 EVENT LOG (Cont.)

Event Type	Event ID	
Config error DSP Error Fatal error General error Indication Alarm Network 'n' Active Indication Alarm Network 'n' Inactive Indication Alarm Network 'n' Acknowledged Instrument event Network 'n' error Power Module 'n' error Process Alarm External 'n' Active Process Alarm External 'n' Inactive Process Alarm External 'n' Acknowledged Process Alarm Network 'n' Active Process Alarm Network 'n' Inactive Process Alarm Network 'n' Acknowledged Restart Error Standby Error System Alarm Network 'n' Active System Alarm Network 'n' Inactive System Alarm Network 'n' Acknowledged <div style="border: 1px solid black; padding: 2px; display: inline-block;"> 'n' = 1, 2, 3 or 4 </div>	EXTERNAL PROCESS ALARMS	POWER MODULE POST ERRORS
	Deviation Band	Comms error
	Deviation High	Comms timeout
	Deviation Low	Fuse blown
	High	Power rail fail
	Low	Watchdog
	FATAL ERRORS	PROCESS ALARMS
	Internal Fuse configuration	Chop Off
	Restart Failure	Closed loop
	CONFIG ERRORS	Main voltage fault
	Invalid parameter database	Output short circuit
	Invalid wiring table	Partial load fault
	INDICATION ALARMS	Partial load unbalance
	Limit active	Temperature pre-alarm
	Load over current	Total Load Failure
	Load Management over schedule	RESET ERRORS
	Process Value transfer	Invalid RAM checksum
	GENERAL ERRORS	DSP no response
	Processor watchdog	DSP task Watchdog
	Event Log fault	STANDBY ERRORS
	Power Module 'n' Calibration	Invalid Power Module
	INSTRUMENT EVENTS	Revision
	Cold start	Hardware mismatch
	Config entry	Power Module 'n' Ribbon
	Config exit	Fault
	Global Acknowledge	SYSTEM ALARMS
	Power down	Fuse Blown
	Quickstart entry	Mains Frequency Fault
	Quickstart exit	Missing mains
	NETWORK ERRORS	NetworkDip
	Phase 'n' power module Comms	Over Temperature
	err	Power Module 24V fault
Phase 'n' power module Timeout	Thyristor Open circuit	
Phase 'n' power module watchdog	Thyristor Short circuit	

Table 5.2.2 Event types and IDs

Notes:

1. Event ID 'Fuse blown' may appear in association with either Event Type 'System Alarm Network 'n'' or Event Type 'Power module 'n' Error'.
2. Event ID 'Watchdog' appears in association with Event Type 'General error' and indicates that the microprocessor in the Driver Module has performed a watchdog reset.
3. Event ID 'Watchdog fault' appears with Event Type 'Power Module 'n' Error' and indicates that the relevant Power Module PIC microprocessor has performed a watchdog reset.

5.2.3 Strategy Standby mode

For SCADA systems, in order to determine Standby mode, the user should use bit 8 of the [Faultdet.Strategy-Status parameter](#), not the [Instrument.Mode](#) parameter.

This is because Instrument Mode reflects user selection, not error states such as Hardware Mismatch.

6 ENGINEER AND CONFIGURATION LEVEL MENUS

These two menu sets are mostly identical, displaying the unit's parameters in a number of sub-menus. As the Engineer level menu is accessible whilst the Driver Module is on-line to the power module(s), the majority of the displayed items are Read Only (i.e. they can be viewed, but not edited), although some non-critical items can be changed.

Full configuration may be carried out from the Configuration level menus, which (apart from the access menu) contain the same parameters as the equivalent Engineering level menus. It is normally recommended, however, that configuration be carried out from a pc running iTools configuration software. In either case, the unit goes off-line as soon as Configuration mode is entered.

6.1 ACCESS TO THE ENGINEER AND CONFIGURATION MENUS

6.1.1 Engineer level menu

The Engineer level menu is entered as follows (figure 6.1.1):

1. Operate the return key repeatedly, until no further changes occur, then hold the Return key continuously operated until the 'Access' 'Goto' display appears.
2. Use the up or down arrow key until 'Engineer' appears.
3. Either wait for a few seconds or operate the Enter key.
4. Use the up or down arrow key to change the code to the Engineer level code (factory default = 2, but reconfigurable in the CONFIG level menu)
5. Either wait for a few seconds or operate the Enter key to display the first Summary Page. Press and hold the Enter key until the first page of the top level Engineer menu appears.



Note: when entering from configuration level no password is required. Once Engineer level has been selected, the unit restarts in the Engineer top level menu

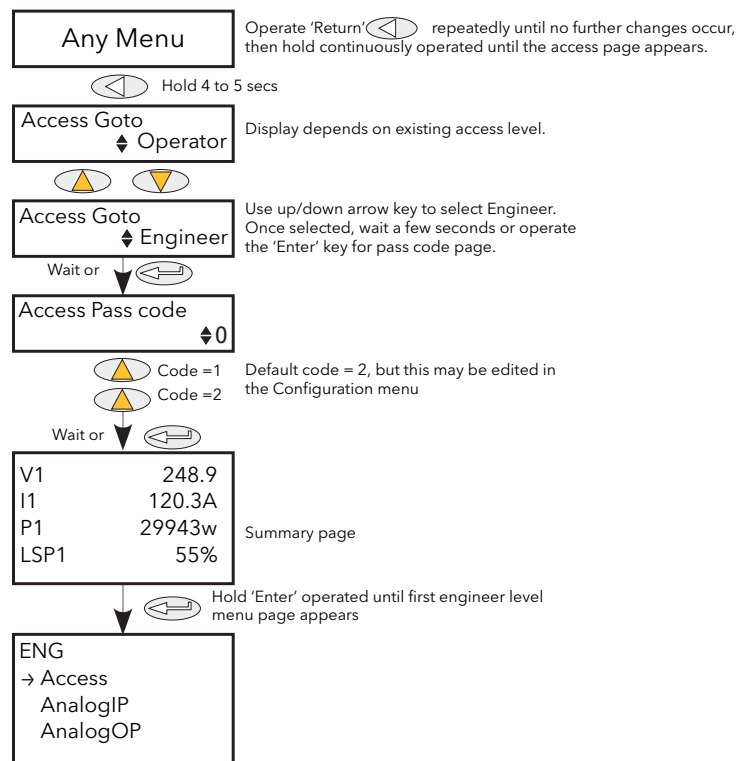

Figure 6.1.1 Access to the Engineer level menu

6.1.2 Configuration level menu

The Configuration level menu is entered as follows (figure 6.1.2):

1. Operate the return key repeatedly, until no further changes occur, then hold the Return key continuously operated until the 'Access' 'Goto' display appears.
2. Use the up or down arrow key until 'Configuration' appears.
3. Either wait for a few seconds or operate the Enter key.
4. Use the up or down arrow key to change the code to the Engineer level code (factory default = 3, but reconfigurable in the CONFIG level Access menu)
5. Either wait for a few seconds or operate the Enter key to display the first page of the top level Configuration menu.

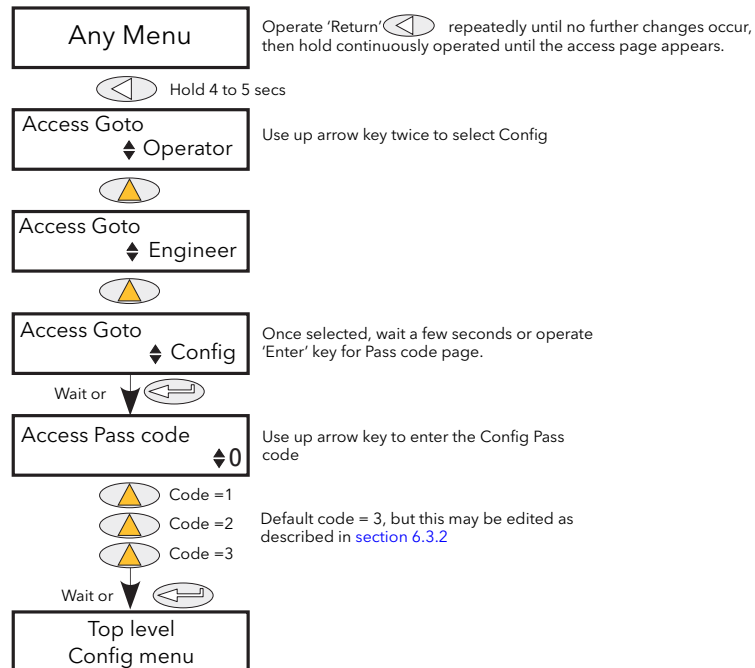

Figure 6.1.2 Access to the Configuration level menu

6.2 TOP LEVEL MENU

Figure 6.2 shows the top level menu for Configuration level. Engineer top level menu similar (Default code = 2).

Submenus are discussed in the following sections:

Note: Section 6 contains descriptions of all the menus which can appear. If an option or a feature is not fitted and/or enabled, then it does not appear in the top level menu.

Access	Section 6.3	Lgc2 logic operator.....	Section 6.16
Analogue I/P	Section 6.4	Lgc8 logic operator.....	Section 6.17
Analogue O/P	Section 6.5	Math2.....	Section 6.18
Comms	Section 6.6	Modulator.....	Section 6.19
Control	Section 6.7	Network.....	Section 6.20
Counter.....	Section 6.8	Predictive Load Management	Section 6.21
Digital I/O.....	Section 6.9	PLM Channels.....	Section 6.22
Energy.....	Section 6.10	Load tap changer.....	Section 6.23
Event Log	Section 6.11	Relay	Section 6.24
Fault Detection	Section 6.12	Setpoint provider.....	Section 6.25
Firing O/P.....	Section 6.13	Timer	Section 6.26
Instrument	Section 6.14	Totaliser.....	Section 6.27
IP Monitor.....	Section 6.15	User value.....	Section 6.28

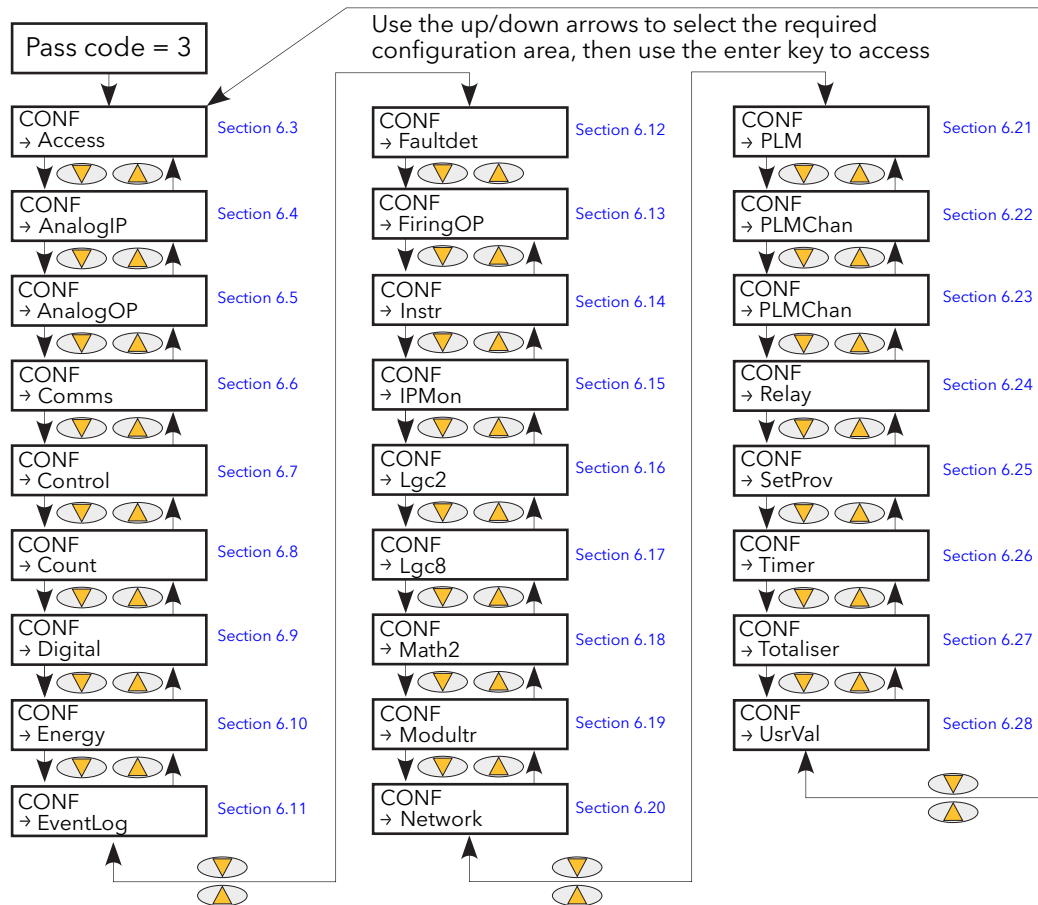

Figure 6.2 Top level menu

6.3 ACCESS MENU

6.3.1 Engineer level menu

Entered from the Engineer top level menu, this allows the user to go to any other menu for which the access code is known. The default access codes are Operator = 1; Engineer = 2, Config = 3, Quickstart = 4.

Figure 6.3.1 below, shows details.

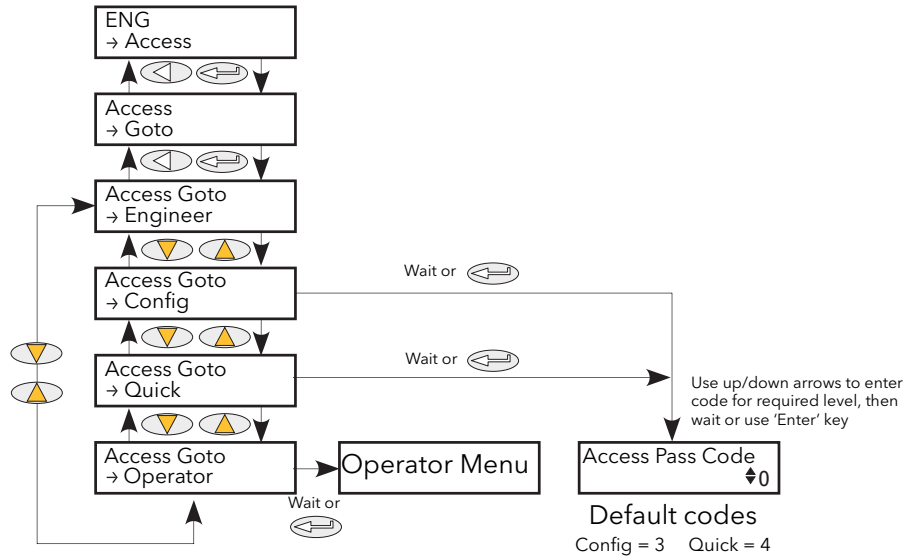

Figure 6.3.1 Engineer level Access menu

6.3.2 Configuration level access menu

This menu allows:

1. The user to quit the Configuration level menu and 'Goto' a different access level. Operator and Engineer level menus require no Pass code as they are considered to be at a lower security level than Configuration. (Figure 6.3.2a shows the menu layout.)
2. The user to edit the current Pass codes for Engineer, Configuration and Quickstart menus (figure 6.3.2b),
3. Access to the Operator Interface push-buttons to be restricted in Operator and Engineer Level menus (figure 6.3.2b).

GOTO MENU

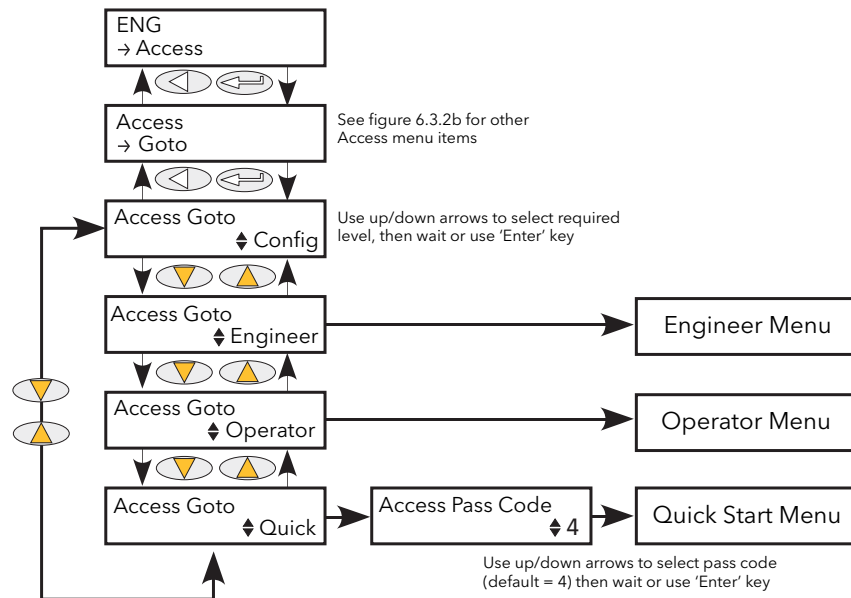

Figure 6.3.2a GoTo menu

To change access level, the 'Enter' key is operated once to select 'Goto', then for a second time to enter the Goto selection page.

The up/down keys are used to select the required access level. After a few seconds, or after a further entry of the 'Enter' key, the unit restarts in the selected level (except for 'Quick Start' which requires the relevant Pass Code (default = 4) to be entered).

6.3.3 CONFIGURATION LEVEL ACCESS MENU (Cont.)

PASS CODE EDITING

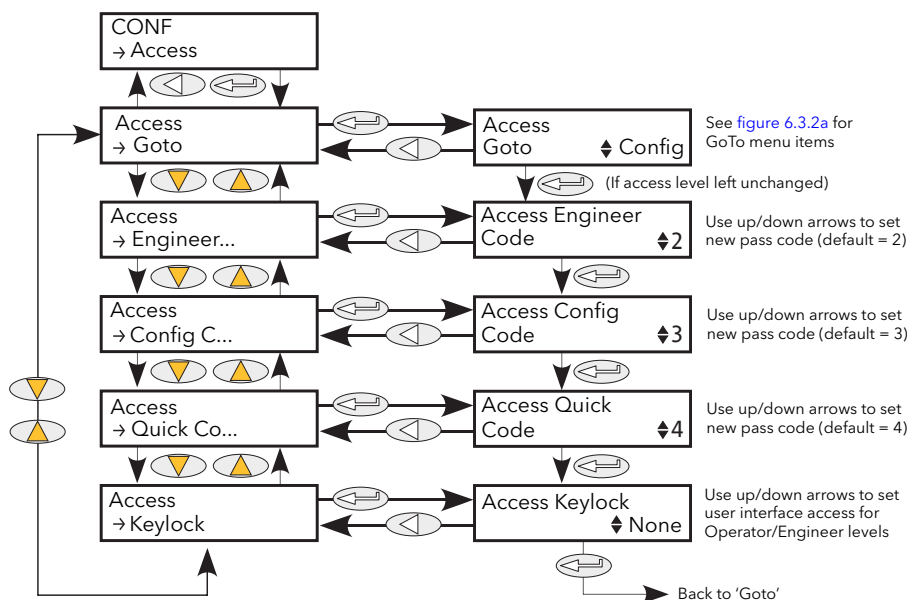

Figure 6.3.2b Access configuration

Code	As depicted above, the 'Enter' key is used to select 'GoTo', then the up/down keys are used to select the required access level's Pass code for editing. Once the required level is selected (e.g. Engineer), the 'Enter' key is used once more, to enter the edit page, where the current Pass Code is displayed (e.g. 2). The up/down keys can now be used to enter a new value of between 0 and 9999. If 0 is selected, then the relevant menu will no longer be pass code protected. After a few seconds, the new value blinks once to confirm that it has been written into the configuration.
KeyLock	<p>None: No restriction. All parameters at the current access level may be viewed and edited.</p> <p>All: All editing and navigation is prevented. All keys are locked so it is not possible to 'undo' this action from the Operator interface. Once 'All' is selected, the keyboard can be released only via iTools.</p> <p>Edit: Parameter editing is possible only in Configuration level; parameters are Read Only in other levels. In the Operator or Engineer level menus, the 'Back' key is still active allowing access to the 'Goto' menu so that the access level may be changed if the relevant Pass code is known.</p>

Note: Keylock is available only from the user interface (i.e. it cannot be accessed from iTools or over a communications link.)

6.4 ANALOGIP MENU

This menu item appears only if one or more analogue inputs have been configured as anything but 'Off' in Quickstart, or if one or more analogue inputs has been enabled using iTools.

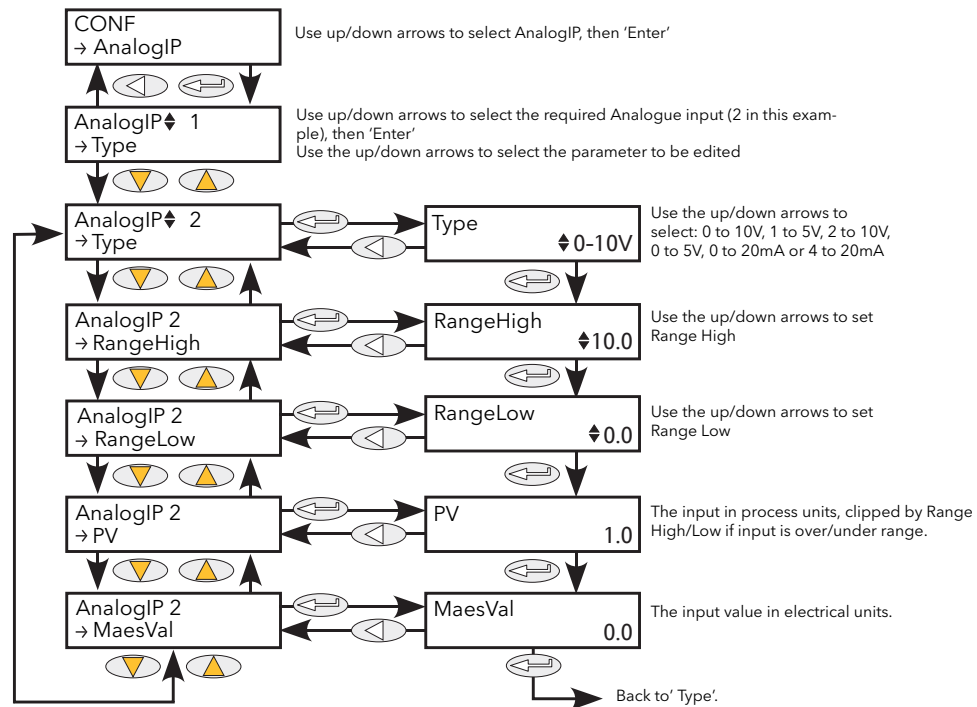

Figure 6.4 Analogue input menu

6.4.1 Analogue input parameters

Type	Allows the type of input to be set as one of: 0 to 10V, 1 to 5V, 2 to 10V, 0 to 5V, 0 to 20mA, 4 to 20mA.
RangeHigh	High range of input for scaling from measurement units to process units. PV is clipped to range high if input goes over range.
RangeLow	Low range of input for scaling from measurement units to process units. PV is clipped to range low if input goes under range.
PV	The scaled value in process units. Clipped to the Range High or Range Low value if the signal goes over range or under range respectively.
MeasVal	The value at the instrument terminals in electrical units.

6.5 ANALOGOP MENU

This menu item appears only if one or more analogue outputs have been configured as anything but 'Off' in Quickstart, or if one or more analogue outputs has been enabled using iTools.

This provides a current or voltage output scaled from a Process Variable (PV) using Range High and Range Low. Figure 6.5.1 shows the 'Main' configuration submenu; figure 6.5.2 shows the alarm parameters.

6.5.1 Analogue output 'Main' submenu parameters

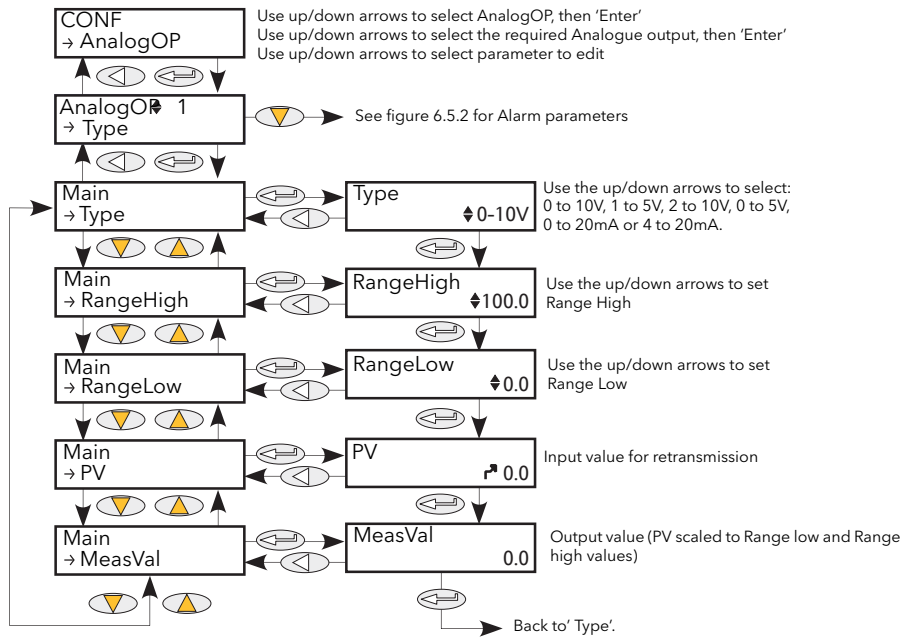

Figure 6.5.1 Analogue output 'Main' menu

Type	Allows the output type to be set as one of: 0 to 10V, 1 to 5 V, 2 to 10V, 0 to 5V, 0 to 20mA, 4 to 20mA.
RangeHigh	Used to scale the Process Variable (PV) from Process units to electrical units.
RangeLow	Used to scale the PV from Process units to electrical units.
PV	The value to be output by the analogue output.
MeasVal	The electrical output value derived by mapping the input PV via input range to output range.

6.5.2 Analogue output 'Alm' parameters

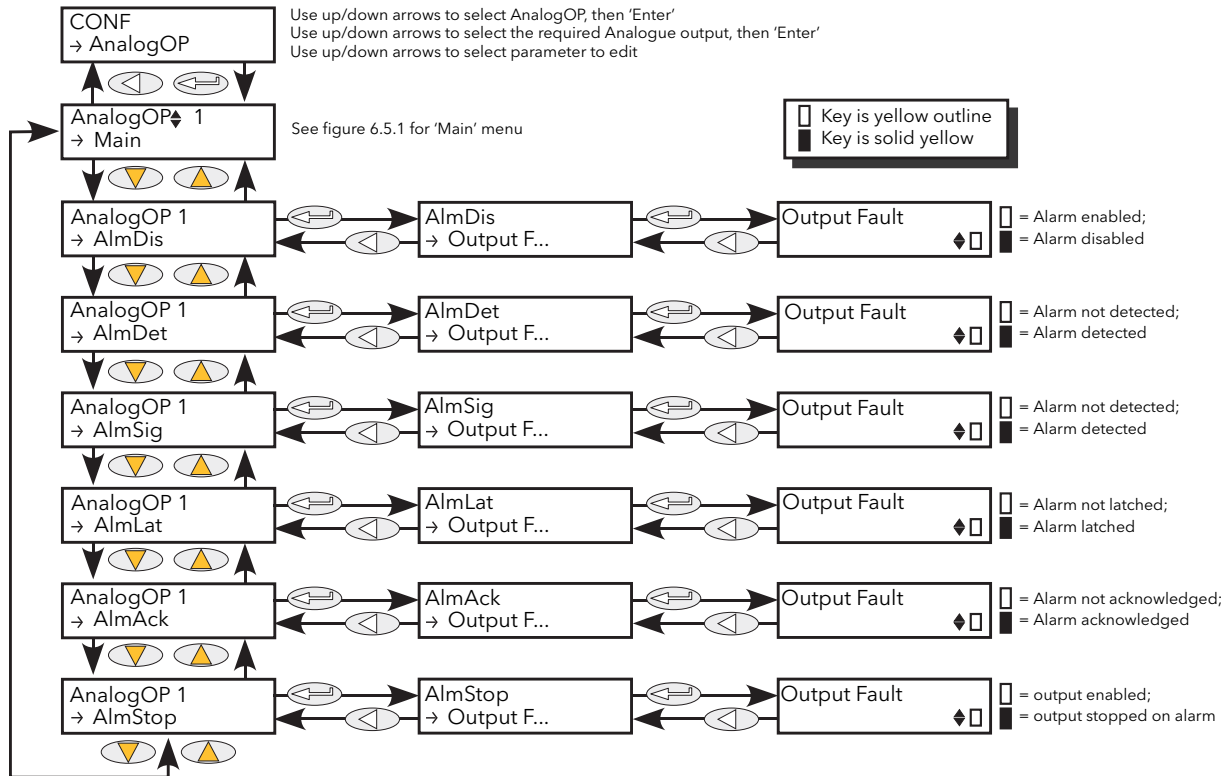

Figure 6.5.2 Analogue output alarm parameter access

AlmDis	Allows the user to view the current disable status of the output Fault alarm.
AlmDet	Indicates whether the alarm has been detected and is active.
AlmSig	Signals that the alarm has occurred and whether it is latched. To assign the alarm to a relay (for example), it is the AlmSig parameter that should be wired.
AlmLat	Allows the user to set the alarm as latching or non-latching.
AlmAck	Allows the user to view the current acknowledgement status of the output Fault alarm.
AlmStop	Allows the user to set up the alarm to disable Power Module firing whilst active.

Note: Output fault may be triggered by either short circuit or open circuit.

6.6 COMMS MENU

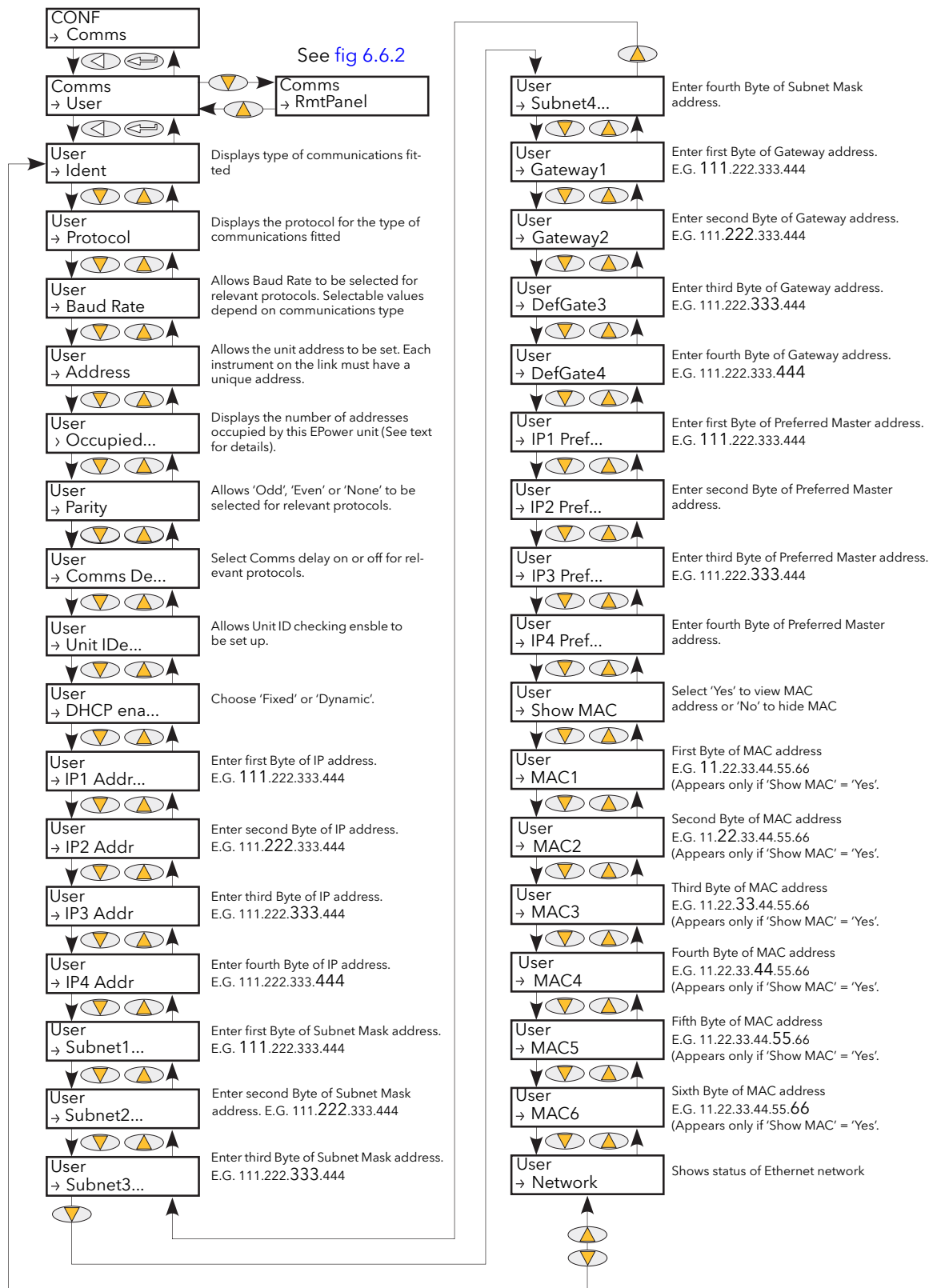

Figure 6.6 Communications User menu

6.6 COMMS MENU (Cont.)

This menu allows the user to view, and in some cases, to edit communications parameters associated with the communications option. The user may also view the Address and Baud Rate parameters associated with the Remote Panel option.

6.6.1 Communications User menu parameters

The following parameter list includes all parameters which can appear. Only those parameters which are relevant to the fitted communications option appear in the menu list.

ID	Displays the type of communications board fitted: RS-485 (EIA 485), Ethernet, or a Network comms board such as Profibus or DeviceNet. (These options are fully discussed in the Communications manual, HA179770.) ID is not user editable.
Protocol	Read only. Displays the current transmission protocol: Modbus, Modbus TCP, Network, Profibus, DeviceNet, CANopen, CC-Link, EtherNet/IP.
Baud	Allows the Baud rate setting for the unit to be set. Available values vary according to the type of communications board fitted.
Address	Allows the instrument address to be set up. Each instrument in a communications link must have a unique address allocated to it. The available address ranges vary according to link protocol.
Occupied Stations	Appearing for CC-Link protocol only, this read-only value shows the number of addresses occupied by the unit, according to the number of input and output definitions are set up (in iTools Fieldbus I/O Gateway), and as shown in the table below. For example, if the address of this unit is 4, and the number of occupied stations is 3, then the next available address is 7.

Number of occupied stations	Maximum No. of input definitions	Maximum No. of output definitions
1	3	4
2	7	8
3	11	12
4	15	16

Input definition:
2-byte word parameter to be read by the master.
Output definition:
2-byte word parameter to be written by master.

Parity	Allows the parity setting to be selected as None, odd or Even. None is often used because there are other corruption detection methods (e.g. CRC) in use, and selecting 'Odd' or 'Even' increases the number of bits transmitted, thus reducing throughput.
Delay	Selects Transmission Delay 'On' or 'Off'. 'On' inserts a guaranteed 10 millisecond delay between reception and response. This is needed by some converter boxes in order to switch driver direction.
Unit ident	Enables/disables the checking of the Modbus TCP Unit Identity field. Strict: The Modbus TCP Unit Identity Field (UIF) does not have to match the instrument address. The instrument responds only to Hex value FF in the UIF. Loose: The Modbus TCP Unit Identity Field (UIF) does not have to match the instrument address. The instrument responds any value in the UIF. Instr: The Modbus TCP Unit Identity Field (UIF) must match the instrument address or no response will be made to messages. A value of 0 in the UIF is treated as a 'Broadcast Message'.
DHCP Enable	Allows the user to choose whether the IP address and subnet mask are fixed or to be supplied by a DHCP Ethernet server.
IP1 Address	The first byte of the IP address. (If the IP address were to be 111.222.333.444, then the first byte would be 111; the second byte 222, and so on).
IP2 to IP4 Address	As IP address 1, but for the remaining three Bytes.
Subnet1 to Subnet4 Mask	As IP Address 1 to 4, but for the Subnet Mask
Gateway1 to 4	As IP Address 1 to 4, but for the Default Gateway.
IP1 Pref Master to IP4 Pref Master	As for IP Address 1 to 4, but for the Preferred Master.

Local network information (IP address, subnet mask address etc.) is normally supplied by the user's IT department.

6.6.1 COMMUNICATIONS USER MENU PARAMETERS (Cont.)

Show MAC	Allows the user to choose whether the unit's MAC address may be shown (Yes), or not (No).
MAC1	Appears only if Show MAC (above) is set to 'Yes'. This is the first byte of the non-editable MAC address. (If the MAC address were to be 11.22.33.44.55.66 then the first byte would be 11; the second byte 22, and so on).
MAC2 to MAC6	As for MAC1, but for bytes two to six respectively
Network	Read Only. Also known as 'Ethernet Status'. Shows the status of the communications link, as follows: Running: Link connected and running Init: Communications initialising Ready: Network ready to accept connection Offline: Network offline Bad: Network Status Bad GSD (Profibus only)
NetStatus	Read Only. Appears to 'Fieldbus' protocols only. Shows the status of the communications network, as follows: Setup: Anybus module set-up in progress Init: Anybus module is initialising network-specific functionality Ready: Process Data channel ready but inactive Idle: Interface is inactive Active: Process Data channel is active and error free Error: One or more errors have been detected Fault: Host fault detected.

6.6.2 COMMS REMOTE PANEL PARAMETERS

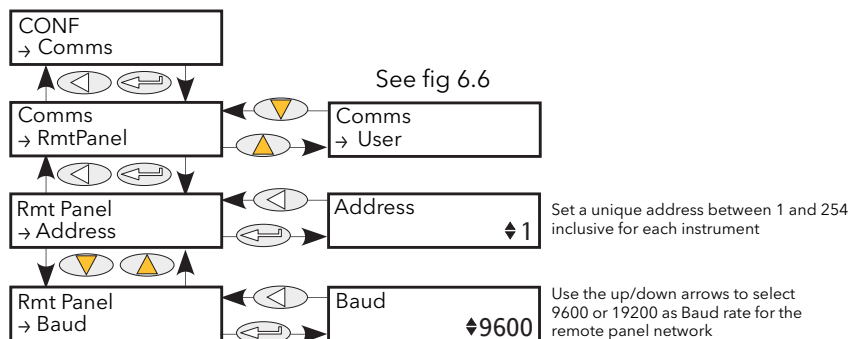

Figure 6.6.2 Communications remote panel menu

Address	Each instrument on the link must be given a unique address between 1 and 254 inclusive. This may be the same or different from the address set in the CONF 'User' Menu (section 6.6.1).
Baud	Displays the Baud rate for the Remote panel communications. Either 9600 or 19200. This may be the same or different from the Baud rate set in the CONF 'User' Menu (section 6.6.1).

Note: Remote Panel parity setting should be set to 'No parity' or 'None'.

6.7 CONTROL MENU

The control menu provides the control algorithm to perform power control and transfer, threshold limiting and phase angle reduction (in the case of burst firing). Figure 6.7, below, gives an overview of the menu, which is described in the following sections:

- 6.7.1 Setup
- 6.7.2 Main
- 6.7.3 Limit
- 6.7.4 Diag (Diagnostics)
- 6.7.5 AlmDis (Alarm disable)
- 6.7.6 AlmDet (Alarm detection)
- 6.7.7 AlmSig (Alarm signalling)
- 6.7.8 AlmLat (Alarm latch)
- 6.7.9 AlmAck (Alarm Acknowledge)
- 6.7.10 AlmStop (Stop firing on alarm)

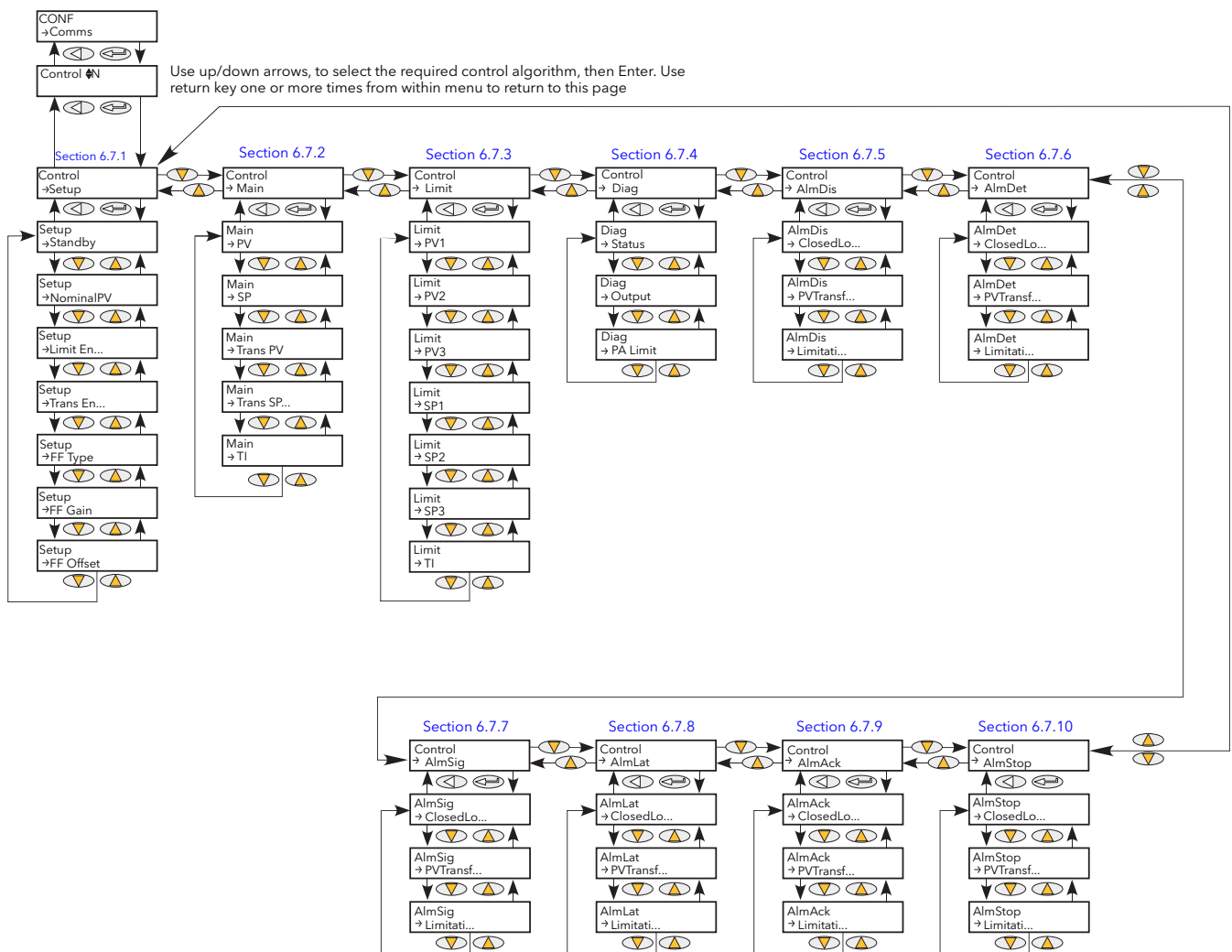

Figure 6.7 Control menu

6.7.1 Control Setup Parameters

This contains parameters for setting the type of control to be performed.

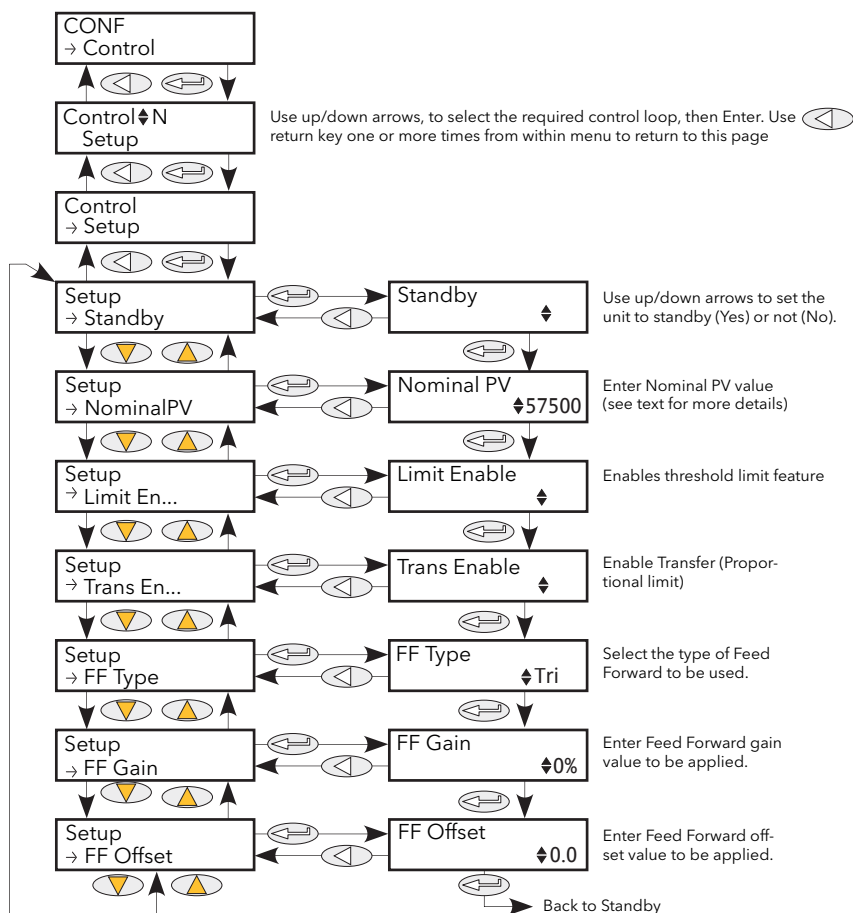

Figure 6.7.1 Control setup menu

Standby	If Yes, the controller enters Standby mode and zero % power is demanded. When removed from Standby the unit returns to operating mode in a controlled manner.
Nominal PV	Normally the nominal value for each control type. For example, for feedback mode = V^2 , V_{sq} should be wired to the Main PV, and Nominal PV set to the nominal value expected for V^2 (usually $V_{LoadNominal}^2$).
Limit Enable	Used to enable/disable threshold limit.
Trans Enable	Select Transfer Enable (Proportional limit) as 'Yes' (enabled) or 'No' (not enabled).
FFType	Feedforward Type. Off: Feedforward is disabled Trim: Feedforward value is the dominant element of the output. Trimmed by the control loop based on the Main PV and setpoint. FFonly: The feedforward value is the output from the controller. Open loop control may be configured by this means.
FFGain	Feedforward is for use only with the main control elements, and the limit loop will override feedforward. The entered gain value is applied to the Feedforward input.
FFOffset	The entered value is applied to the Feedforward input after the Gain value has been applied to it.

6.7.2 Control Main Parameters

This menu contains all the parameters associated with the Main control loop.

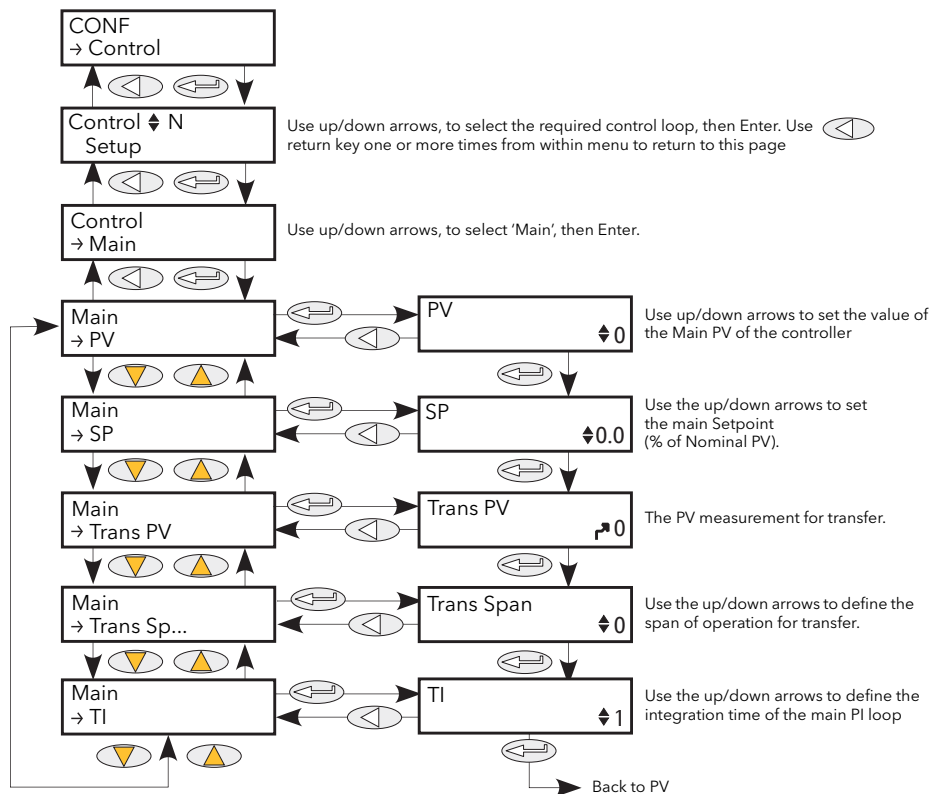

Figure 6.7.2 Control Main parameters

- PV Displays the main Controller Process Variable (PV). Wired to the measurement which it is to be controlled. For example, to perform V^2 control. V_{sq} should be wired to this (PV) parameter and Nominal PV configured appropriately (section 6.7.1).
- SP The Setpoint to control at, as a percentage of Nominal PV (the upper range of the loop in engineering units). For example, if $NominalPV = 500V\ RMS$, and SP is set to 20%, the controller attempts to regulate at $500 \times 20/100 = 100V\ RMS$. If Transfer or Limit is enabled, these will override SP.
- Trans PV Transfer PV. This is the PV measurement for transfer. For example, if a V^2 to I^2 transfer is required, the V_{sq} should be wired to MainPV and I_{sq} to TransferPV. Appears only if Trans Enable (section 6.7.1) is set to 'Yes' (via iTools).
- Transfer Span The span of operation for transfer. Appears only if Trans Enable (section 6.7.1) is set to 'Yes' (via iTools).
- TI Allows the user to define an integral time for the main PI control loop.

6.7.3 Control Limit parameters

Parameters relating to the limit control loop.

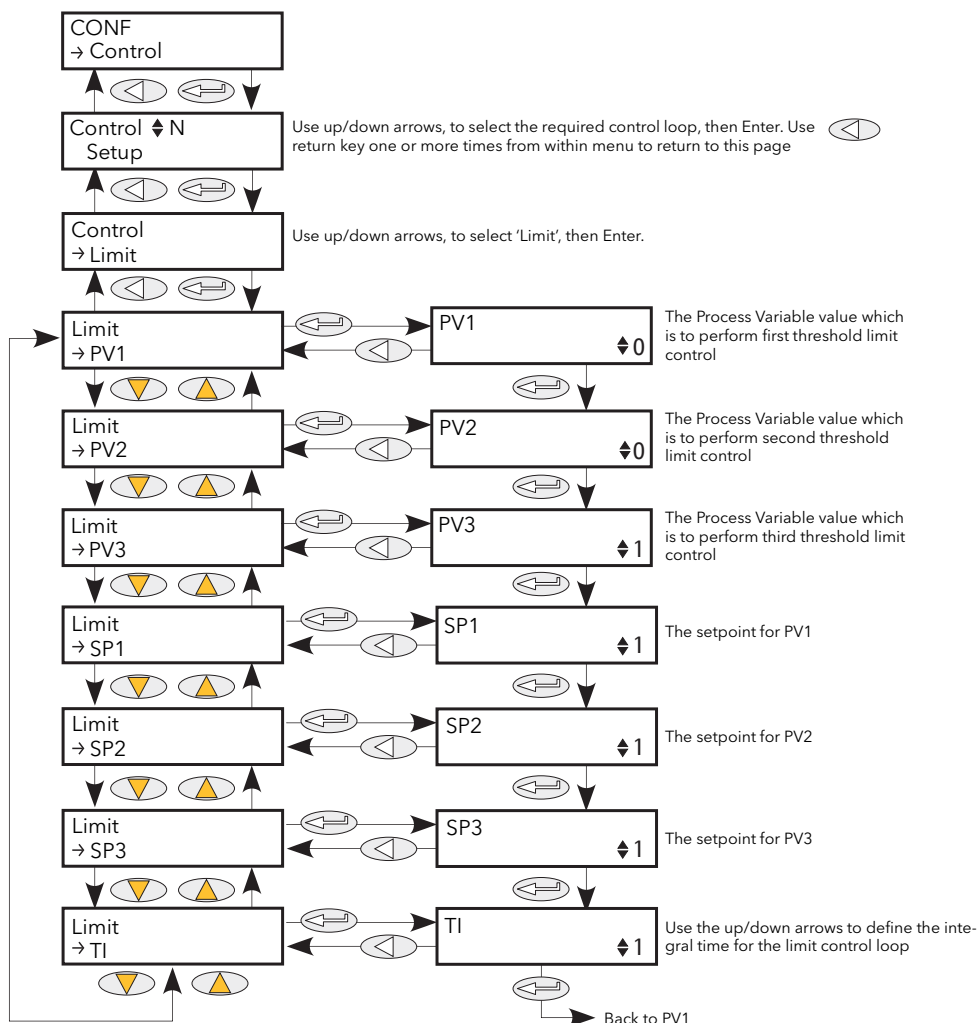

Figure 6.7.3 Control Limit menu

PV1 to PV3	Threshold value for limit loops 1 to 3 respectively. This is the value to perform threshold limit control. 'Limit Enable' must be set to 'Yes' in the Setup menu (section 6.7.1).
SP1 to SP3	The setpoint for limit loops 1 to 3 respectively.
TI	The integration time for the limit PI control loop.

Example:

If I^2 threshold limiting is required, I_{sq} is wired to PV1, and the required threshold value is entered at SP1. In phase angle configuration, the phase angle is reduced to achieve the limit setpoint; in burst firing, the unit continues to fire in bursts, but these bursts are of phase angle in order to achieve the limit setpoint. The modulation continues to attempt to reach the main setpoint.

Also known as phase angle reduction burst firing.

6.7.4 Control Diag parameters

This menu contains diagnostic parameters related to Control.

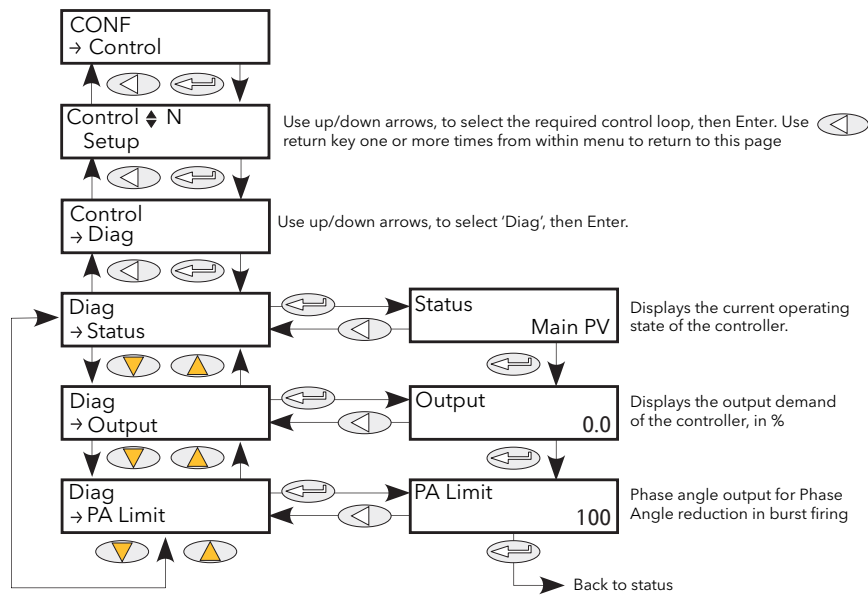

Figure 6.7.4 Control Diag menu

Status	Indicates the current operating state of the controller: Main PV: The control strategy is using Main PV as the control input Transfer function active: The transfer input us being used as the input to the control strategy. Limit 1(2)(3) active: Control limiting is currently active using limit PV1(2)(3) and limit SP 1(2)(3).
Output	The current output demand in percent. Normally wired to Modulator.In or FiringOP.In
PA Limit	Applies only to Burst Firing control modes. If this parameter is wired to FiringOP.PALimit, the power module will deliver bursts of phase angle firing depending both on the Main Setpoint and on the Limit Setpoint.

6.7.5 Control Alarm disable parameters

Allows each alarm of the control block to be disabled, individually. May be wired.

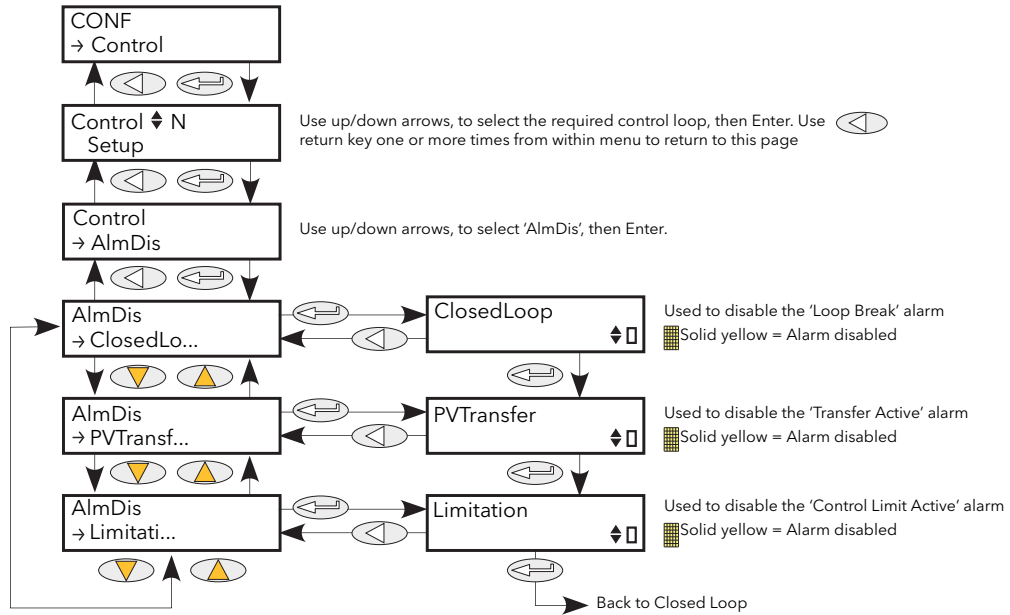

Figure 6.7.5 Control Alarm disable menu

- Closed Loop The 'piano key' in the bottom right corner of the display indicates the current enable status of the closed loop alarm. The up and down arrows are used to enable/disable the alarm. An 'empty' key indicates that the alarm is enabled; a solid yellow key means that the alarm is disabled.
- PV Transfer As for Closed Loop, but for the 'Transfer Active' alarm.
- Limitation As for Closed Loop, but for the 'Control limit active' alarm.

6.7.6 Control Alarm detection parameters

Indicates whether each alarm has been detected and whether or not it is currently active.

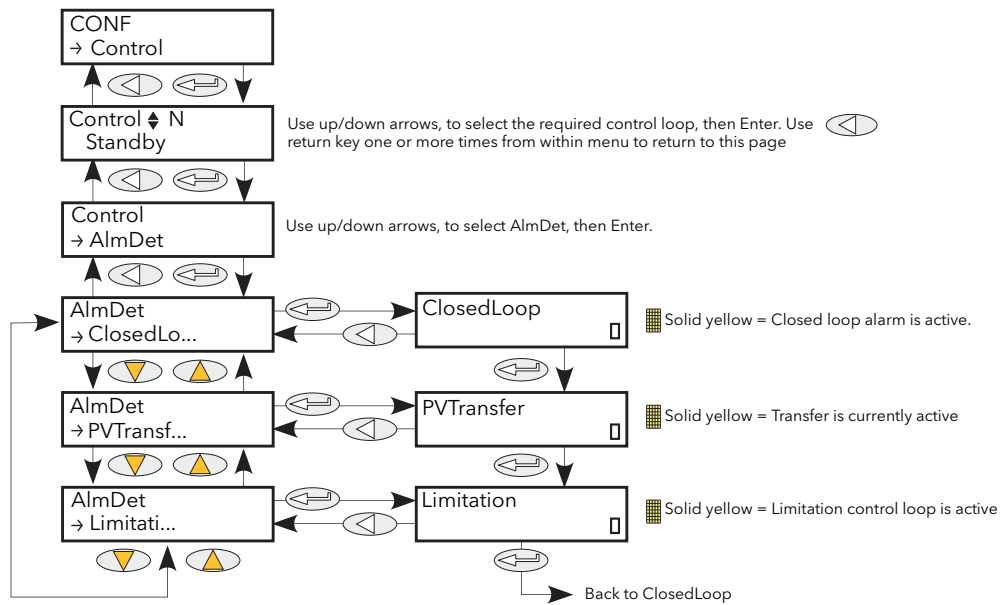

Figure 6.7.6 Control Alarm detection menu

- Closed Loop The 'piano key' in the bottom right corner of the display shows whether or not the closed loop alarm is currently active. An 'empty' key indicates that the alarm is inactive; a solid yellow key means that the alarm is active.
- PV Transfer As for Closed Loop, but for the 'Transfer Active' alarm.
- Limitation As for Closed Loop, but for the 'Control limit active' alarm.

6.7.7 Control Alarm signalling parameters

Signals that an alarm has occurred and has been latched (if so configured in 'Alarm Latch' (section 6.7.8)). If it is required that an alarm is to be assigned to a relay (for example), then the appropriate alarm signalling parameter should be used.

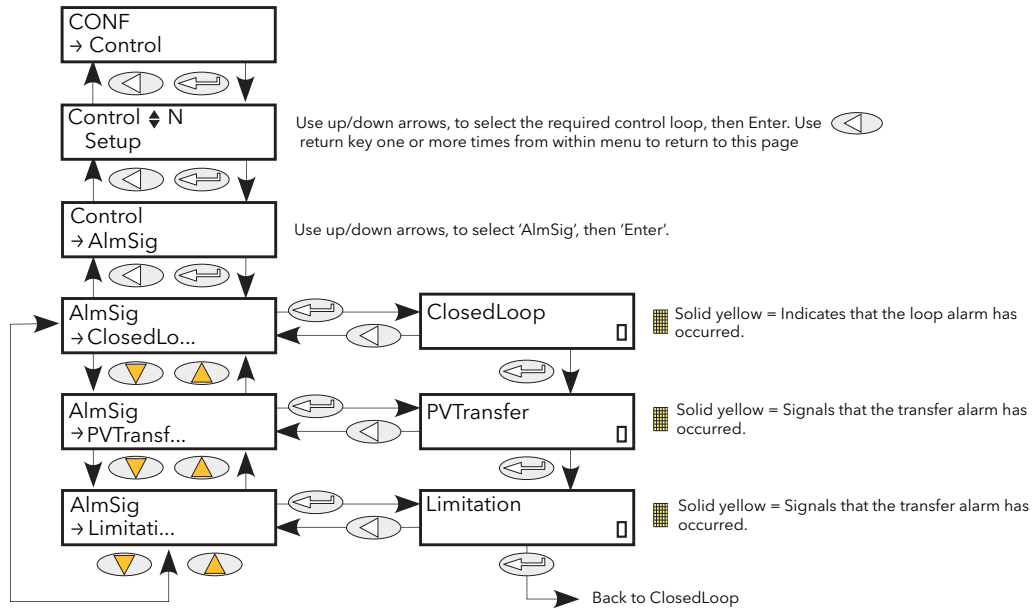

Figure 6.7.7 Control Alarm Signalling menu

- Closed Loop The 'piano key' in the bottom right corner of the display indicates whether the closed loop break alarm is currently active. An 'empty' key indicates that the alarm is inactive; a solid yellow key means that the alarm is active.
- PV Transfer As for Closed Loop, but for the 'Transfer Active' alarm.
- Limitation As for Closed Loop, but for the 'Control limit active' alarm.

6.7.8 Control Alarm Latch parameters

Allows each alarm to be configured as latching or not latching. The latched status is shown in the Network AlmSig submenu (ref [section 6.20.3](#)).

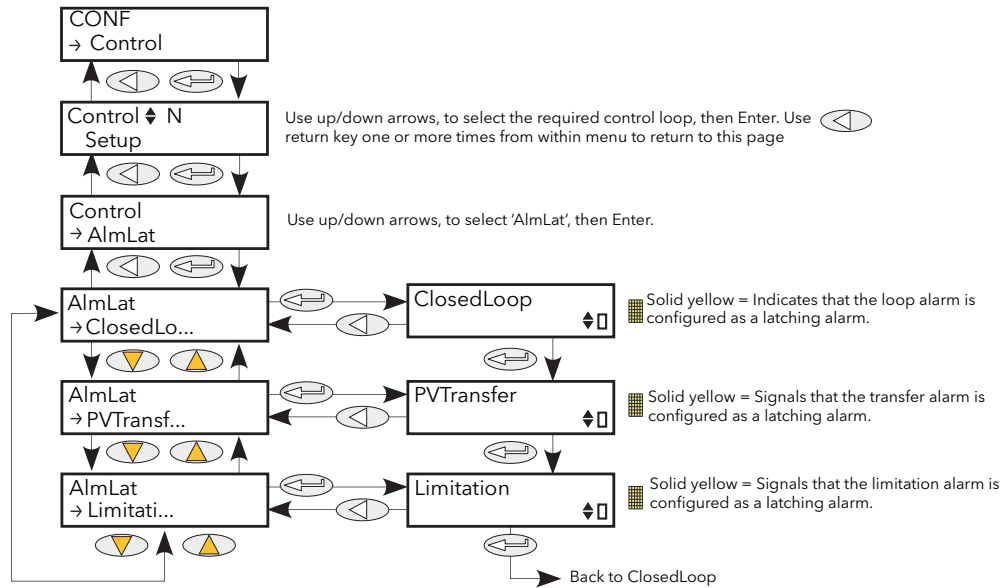

Figure 6.7.8 Control Alarm latching menu

- Closed Loop Use the up/down arrows to change the latching status of the alarm. The 'piano key' in the bottom right corner of the display indicates whether the closed loop alarm is latching (solid yellow) or non-latching ('empty').
- PV Transfer As for Closed Loop, but for the 'Transfer Active' alarm.
- Limitation As for Closed Loop, but for the 'Control limit active' alarm.

6.7.9 Control Alarm Acknowledgement parameters

This menu allows individual alarms to be acknowledged. On acknowledgement, the related Signalling parameter is cleared. The Acknowledge parameters automatically clear after being written.

If the alarm is still active (as shown by the Alarm Detection display) it may not be acknowledged.

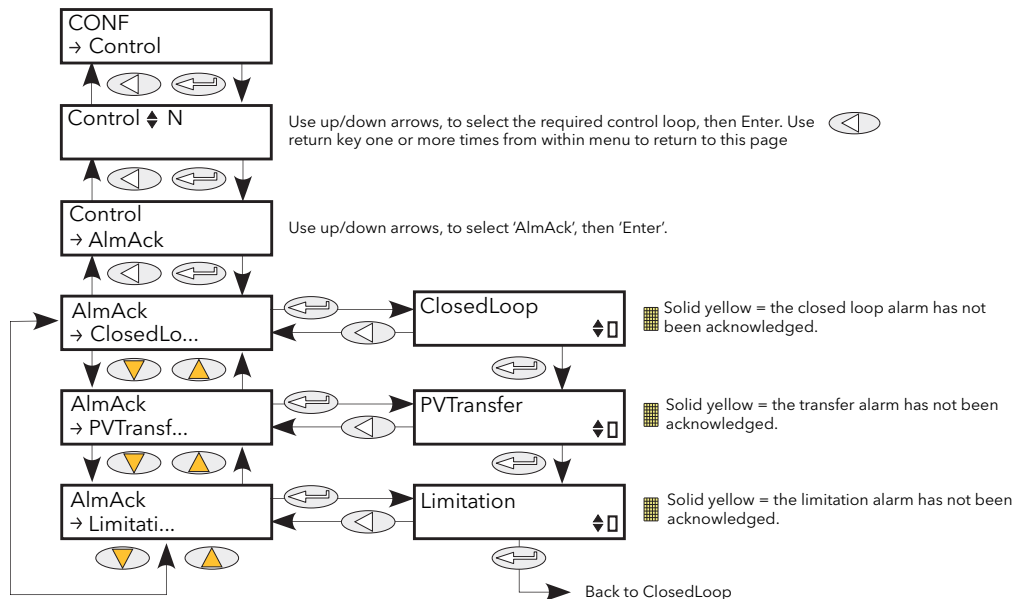

Figure 6.7.9 Control Alarm Acknowledge menu

- Closed Loop The 'piano key' in the bottom right corner of the display shows whether the closed loop alarm has been acknowledged or not. An 'empty' key indicates that the alarm is acknowledged; a solid yellow key indicates that the alarm is unacknowledged. The up/down arrow keys are used to acknowledge.
- PV Transfer As for Closed Loop, but for the 'Transfer Active' alarm.
- Limitation As for Closed Loop, but for the 'Control limit active' alarm.

6.7.10 Control Alarm Stop parameters

Allows individual channels to be configured such that it will stop the associated power channel from firing whilst the alarm is active. This feature is activated by the signalling parameters, so the alarm stop may be latching.

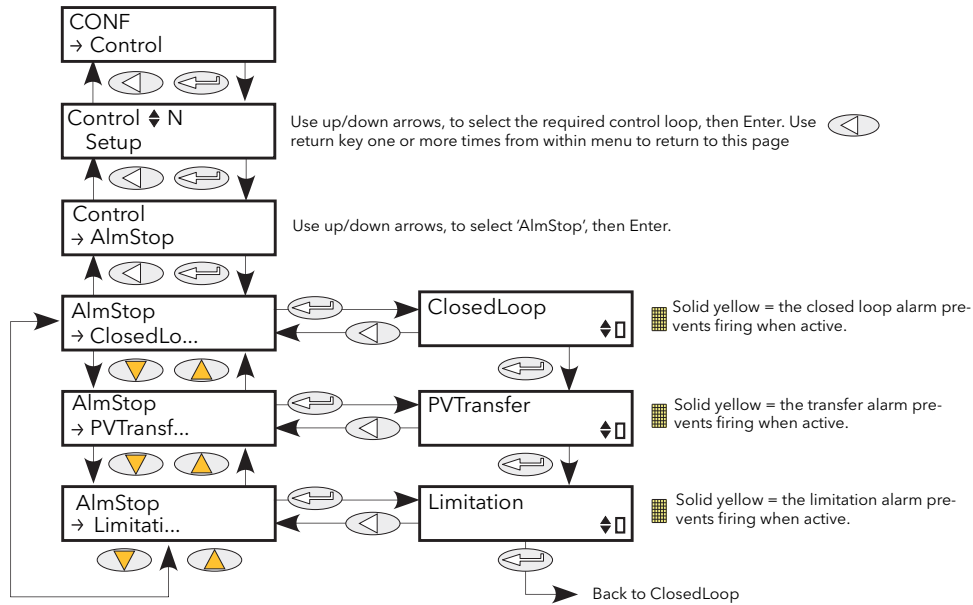

Figure 6.7.10 Control Alarm Stop menu

- Closed Loop The 'piano key' in the bottom right corner of the display shows whether the closed loop alarm has been configured to disable firing or not. An 'empty' key indicates that the firing is enabled; a solid yellow key indicates that the firing is disabled.
- PV Transfer As for Closed Loop, but for the 'Transfer Active' alarm.
- Limitation As for Closed Loop, but for the 'Control limit active' alarm.

6.8 COUNTER MENU

The counter output is a 32-bit integer the value of which is recalculated every sample period. When a clock state change from 0 (false) to 1 (true) is detected the counter value is incremented if the count direction is 'up' or decremented if the direction is 'down'.

At reset, the counter value is set to 0 for count up counters or to the 'Target' value for count down counters.

6.8.1 Counter configuration menu

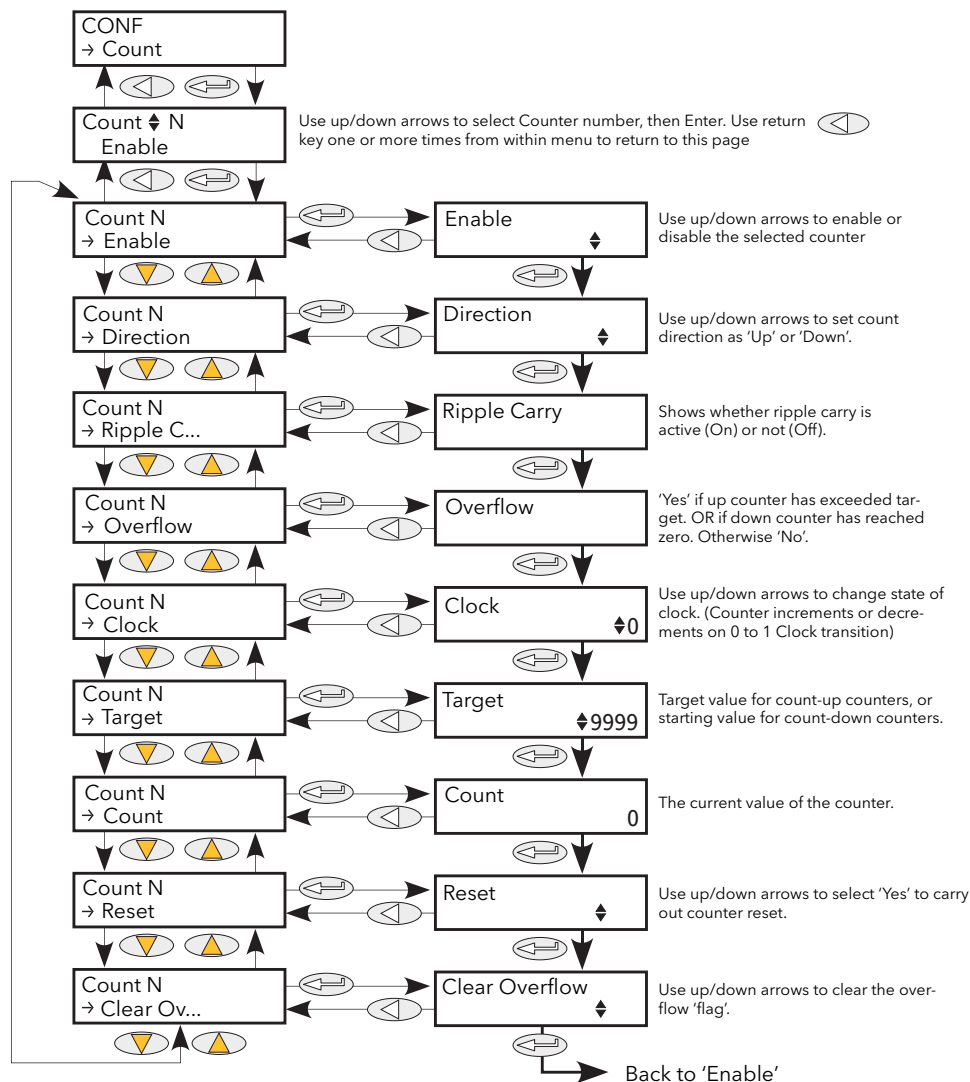

Figure 6.8.1 Counter menu

Enable	The counter responds to clock transitions when enabled; the count is frozen when disabled.
Direction	Select up or down as the direction of count. Up counters start at (and are reset to) zero; down counters start from (and are reset to) the Target value (below)
Ripple Carry	The Ripple carry output of one counter can act as the enabling input for the next counter in a cascade. Ripple carry is set 'true' when the counter is enabled and its value is either zero (for count down timers) or equal to the Target value (count up counters).
Overflow	Overflow becomes 'true' when the value of the counter is either zero (for count down timers) or equal to the Target value (count up counters).
Clock	The counter increments or decrements on a positive going edge (0 to 1; False to true).

6.8 COUNTER MENU (Cont.)

Target	Up counters: Start at zero and count towards the Target value. When this value is reached, Overflow and Ripple-carry are set true (value = 1). Down counters: Start at the Target value and count towards zero. When zero is reached, Overflow and Ripple-carry are set true (value = 1).
Count	The current value of the counter. This is a 32-bit integer which accumulates clock transitions. Minimum value is zero.
Reset	Resets up-counters to zero or down-counters to the Target value. Reset also sets Overflow to False (i.e. Overflow = 0)
Clear Overflow	Sets Overflow to False (i.e. Overflow = 0)

6.8.2 Cascading counters

As implied above, it is possible to 'wire' counters in cascade mode. Details for an 'up' counter are shown in figure 6.8.2, below. Down counter configuration is similar.

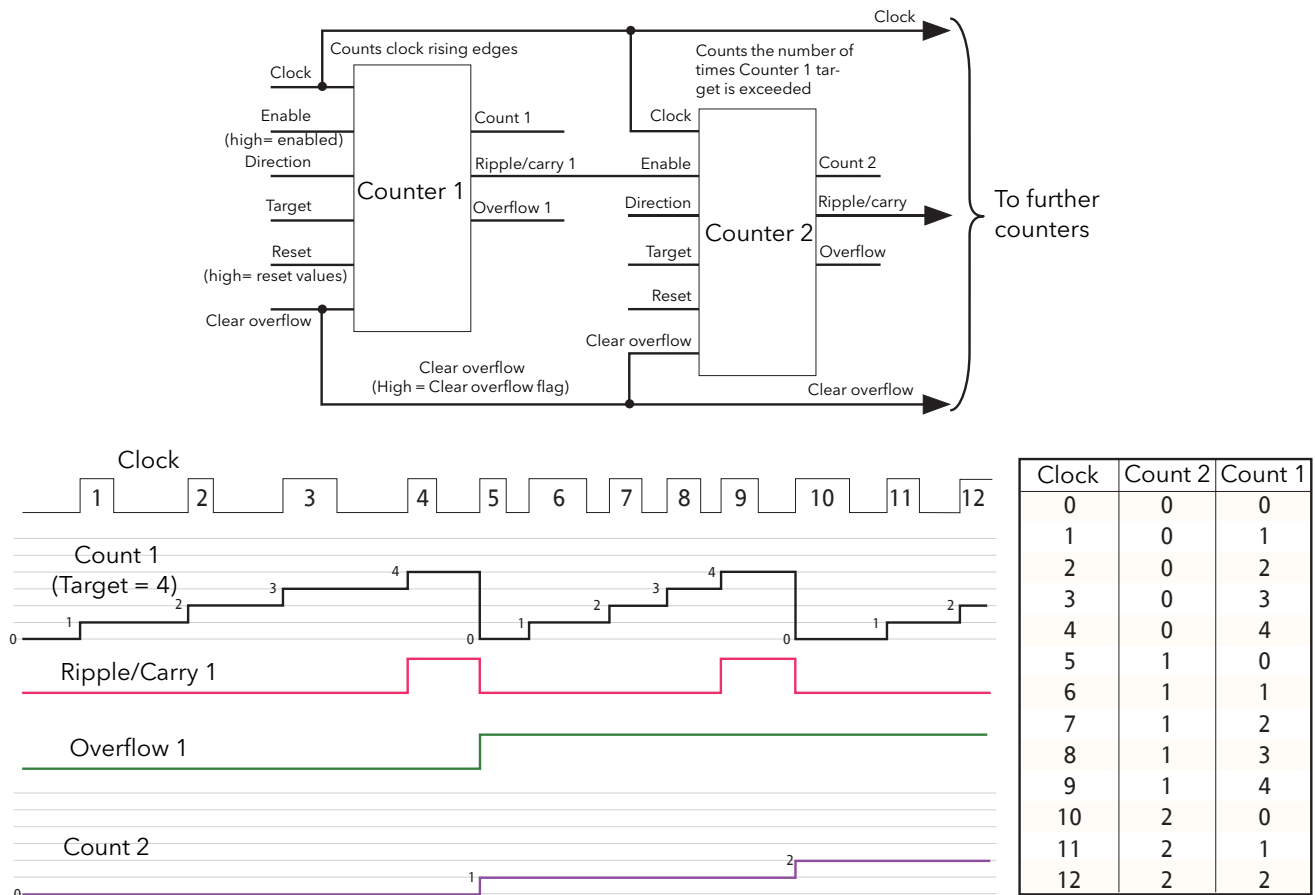

Figure 6.8.2 Cascading up counters

Note: Counter 2 above counts the number of times that Counter 1 target is exceeded. By permanently enabling counter 2, and wiring counter 1 'Ripple Carry' output to counter 2 'Clock' input (replacing the connection to the clock pulse stream), counter 2 will indicate the number of times counter 1 target is reached, rather than exceeded.

6.9 DIGITAL I/O MENU

Digital I/O configuration.

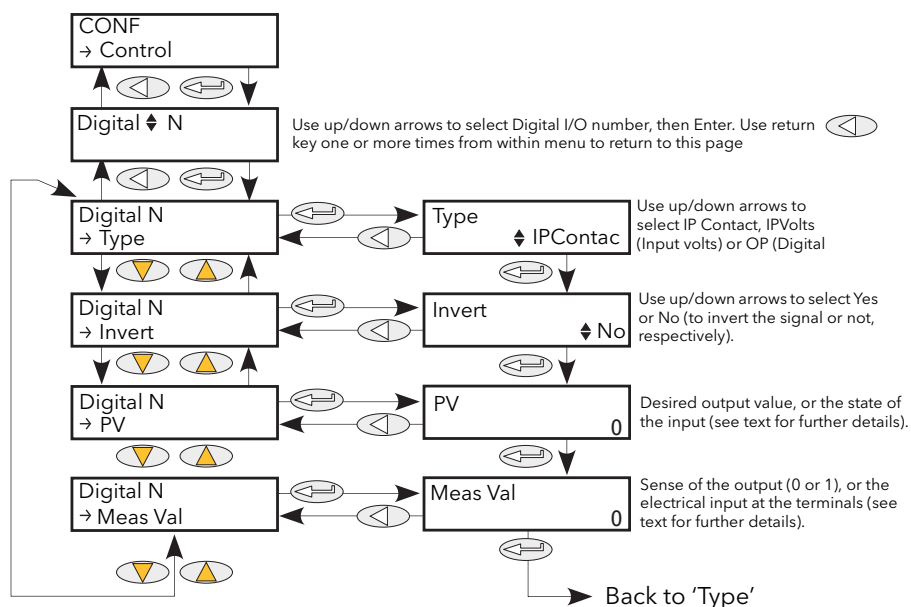

Figure 6.9 Digital I/O menu

Type	Selects I/O type: Logic Input, IPContact or digital output. For pinout details, see figure 2.2.1c .
Invert	Sets the inversion status to 'No' or 'Yes'. For inputs, Yes inverts the input; for outputs, Yes inverts the output measured value with respect to the input PV.
MeasVal	For inputs, this shows the value measured at the instrument terminals, in electrical units. For outputs, this shows 1 or 0 according as the output is high or low.
PV	For inputs, this is the current state of the input, after any inversion has been applied. For outputs, this is the desired output value (before any inversion is applied).

6.10 ENERGY

Provides a number of energy counters to totalise consumed energy. The value(s) can be displayed at the driver module front panel (using iTools [User Pages](#)), and at the remote panel, if fitted. The power consumed can be displayed in one of number of units, ranging from W to GW. Figure 6.10 shows the menu.

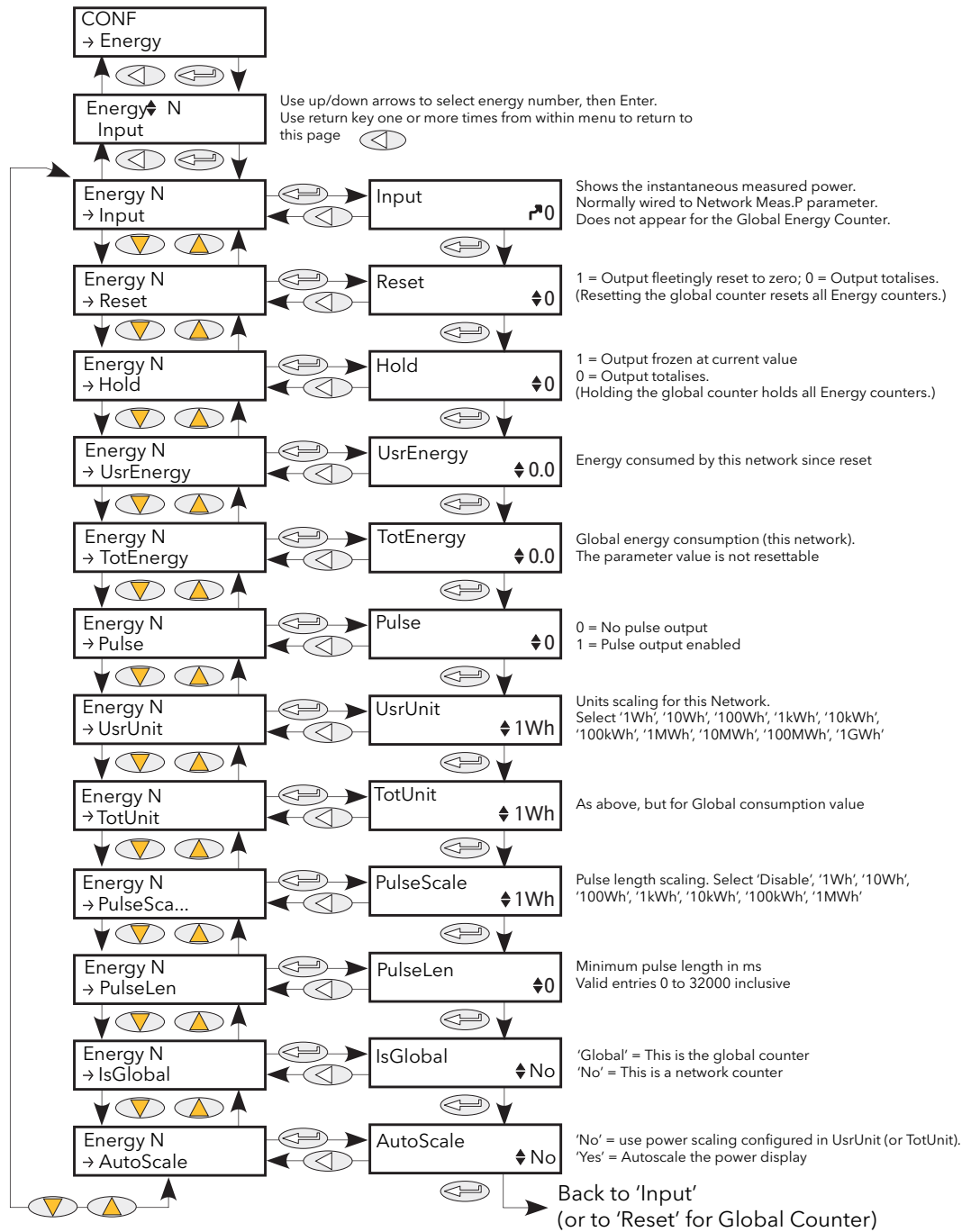

Figure 6.10 Energy counter menu

6.10.1 Energy counter parameters

Input	Shows the instantaneous power input from the measuring source. Normally wired to the Meas.P output of a Network block. Does not appear for the Global Energy Counter (see 'IsGlobal', below).
Reset	1 = Energy counter output goes to zero and immediately starts accumulating. 0 = Energy counter not reset. If the Global Energy counter is reset, it resets all other Energy counters (see 'IsGlobal', below).
Hold	1 = Hold output value. This freezes the output value for the block at the current value. The input continues to be totalised, so when the Hold input returns to 0, the output value is instantaneously updated to the new current value. 0 = output value is not held, and represents the current accumulated Energy value. If the Global Energy counter is held, all other Energy counters are held as well (see 'IsGlobal', below).
UsrEnergy	Shows the current value for the selected Energy Counter block. If this is the global counter, this value is the sum of the energy values of all those networks being totalised.
TotEnergy	Shows the total energy value for the relevant network. Not reset by 'Reset' above.
Pulse	This enables a pulse output which causes a pulse to be generated at a specified number of watt-hours (1, 10, 100kW-h or 1MW-h). The length of the pulse and a scaling factor can be entered, as described below.
UsrUnit	Allows a scaling units value to be entered for the energy display. Selectable as '1Wh', '10Wh', '100Wh', '1kWh', '10kWh', '100kWh', '1MWh', '10MWh', '100MWh' or '1GWh'.
TotUnit	As 'UsrUnit', above, but for the total energy counter.
PulseScale	One pulse is generated every 'n' Watt-hours, where 'n' can be selected as 1, 10, 100, 1k, 10k, 100k, 1M Watt-hours. This value, and that of Pulse Len(gth) must be chosen to suit the application, such that the next pulse is not requested before the previous one is finished. (In such a case, the PulseScale factor is automatically increased.)
PulseLen*	Select pulse length between 0 and 32000 ms. The actual pulse length is rounded to the next longest multiple of 1/2 the supply frequency. Thus, for a 50Hz system (multiple = 10ms) pulse length entries of 1 to 10 will result in a pulse length of 10ms. For entries of 11 to 20 the pulse length will be 20ms, and so on. This value, and that of Pulse Scale must be chosen to suit the application, such that the next pulse is not requested before the previous one is finished. (In such a case, the PulseScale factor is automatically increased.)
IsGlobal	One (only) of the Energy blocks can be defined as being 'Global'. This means that it sums the values of all the other Energy counters. The block 'input' is disabled. The 'IsGlobal' parameter becomes non-editable (set to 'No') for all other Energy counter blocks. If the Global energy Counter is held or reset, all other counters are held and reset as well. 'No' = This counter is not the Global counter. 'Global' = this counter is the Global counter.
Autoscale	No = Use UsrUnit and TotUnit settings. Yes = Autoscale power value display. Table 6.10.1 shows the breakpoints.

* Note: due to the computing time required, the pulse-length may vary according to circumstance. For example, if a 20ms pulse is selected, the actual pulse length may be a mixture of 20ms and 30 ms pulses.

6.10.1 ENERGY COUNTER PARAMETERS (Cont.)

Power Range (Watt-hours)		Scaler value
0	to 65,535	1
65,535	to 65,535,000	1k
65,535,000	to 655,350,000	10k
655,350,000	to 6,553,500,000	100k
6,553,500,000	to 65,535,000,000	1M
65,535,000,000	to 655,350,000,000	10M
655,350,000,000	to 6,553,500,000,000	100M
6,553,500,000,000	upwards	1G

Table 6.10.1 Autoscale breakpoints

6.10.2 Resolution

The resolution of the stored energy value varies according to the totalised value, as shown in table 6.10.2 below. For example, for stored values between 33,554,432 watt-hours and 67,108,863 watt-hours, the value increases in 4 watt-hour increments.

Power Range (Watt-hours)		Resolution (W-h)	Power Range (Watt-hours)		Resolution (W-h)
0	to 16,777,215	1	17,179,869,184	to 34,359,738,367	2,048
16,777,216	to 33,554,431	2	34,359,738,368	to 68,719,476,735	4,096
33,554,432	to 67,108,863	4	68,719,476,736	to 137,438,953,471	8,192
67,108,864	to 134,217,727	8	137,438,953,472	to 274,877,906,943	16,384
134,217,728	to 268,435,455	16	274,877,906,944	to 549,755,813,887	32,768
268,435,456	to 536,870,911	32	549,755,813,888	to 1,099,511,627,775	65,536
536,870,912	to 1,073,741,824	64	1,099,511,627,776	to 2,199,023,255,551	131,072
1,073,741,824	to 2,147,483,647	128	2,199,023,255,552	to 4,398,046,511,103	262,144
2,147,483,648	to 4,294,967,295	256	4,398,046,511,104	to 8,796,093,022,207	524,288
4,294,967,296	to 8,589,934,591	512	8,796,093,022,208	to 17,592,186,044,415	1,048,576
8,589,934,592	to 17,179,869,183	1,024			

Table 6.10.2 Energy counter resolution

6.11 EVENT LOG MENU

This topic is identical with the Event log in the User/Operator menu, and is described in [section 5.2.2](#).

6.12 FAULT DETECTION MENU

This manages Alarm logging and provides an interface for the General Alarm Acknowledgement

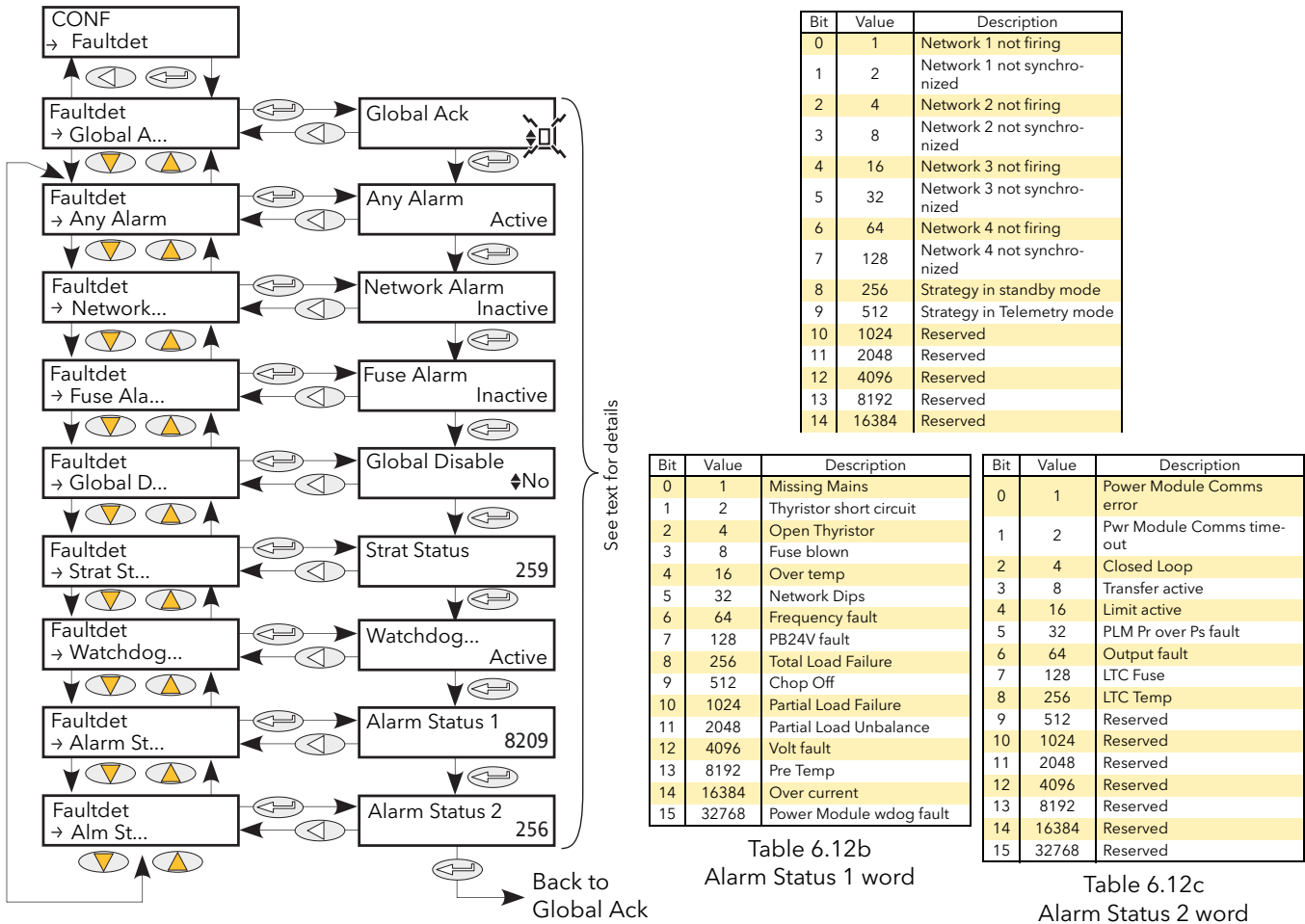

Figure 6.12 Fault detect menu

- Global Ack** Performs a global acknowledgement of alarms. Latched alarms are cleared if their trigger sources are no longer in an alarm state.
- Any Alarm** 'Active' indicates that there is one or more System, Process or 'Chop Off' alarm active. If the relevant alarms are enabled, System alarms and Chop Off alarms always cause the power module to stop firing. Process alarms can also be configured to prevent firing in 'Alarm stop'.
- Network Alarm** Indicates that a process alarm has occurred in one or more Power Modules.
- Fuse Alarm** Indicates that a fuse has blown in one or more Network blocks.
- Global Disable** Allows the user to disable/enable all alarms.
- StratStatus** A coded status word giving strategy information as shown in table 6.12a.
- Watchdog** Watchdog relay status (Active or Inactive). The watchdog relay is active (non-energised) under fault conditions.
- Alarm Status 1/2** Two 16-bit words containing alarm status information as shown in tables 6.12b and 6.12c respectively.

6.13 FIRING OUTPUT MENU

This forms the link between the control strategy and the physical load. Configuration includes Firing mode, Network Type and the type of Load coupling. This block also supplies Phase-Angle Ramp (Soft start) and Safety Ramp.

In Engineer level, these items are mostly Read only (i.e. their values cannot be edited).

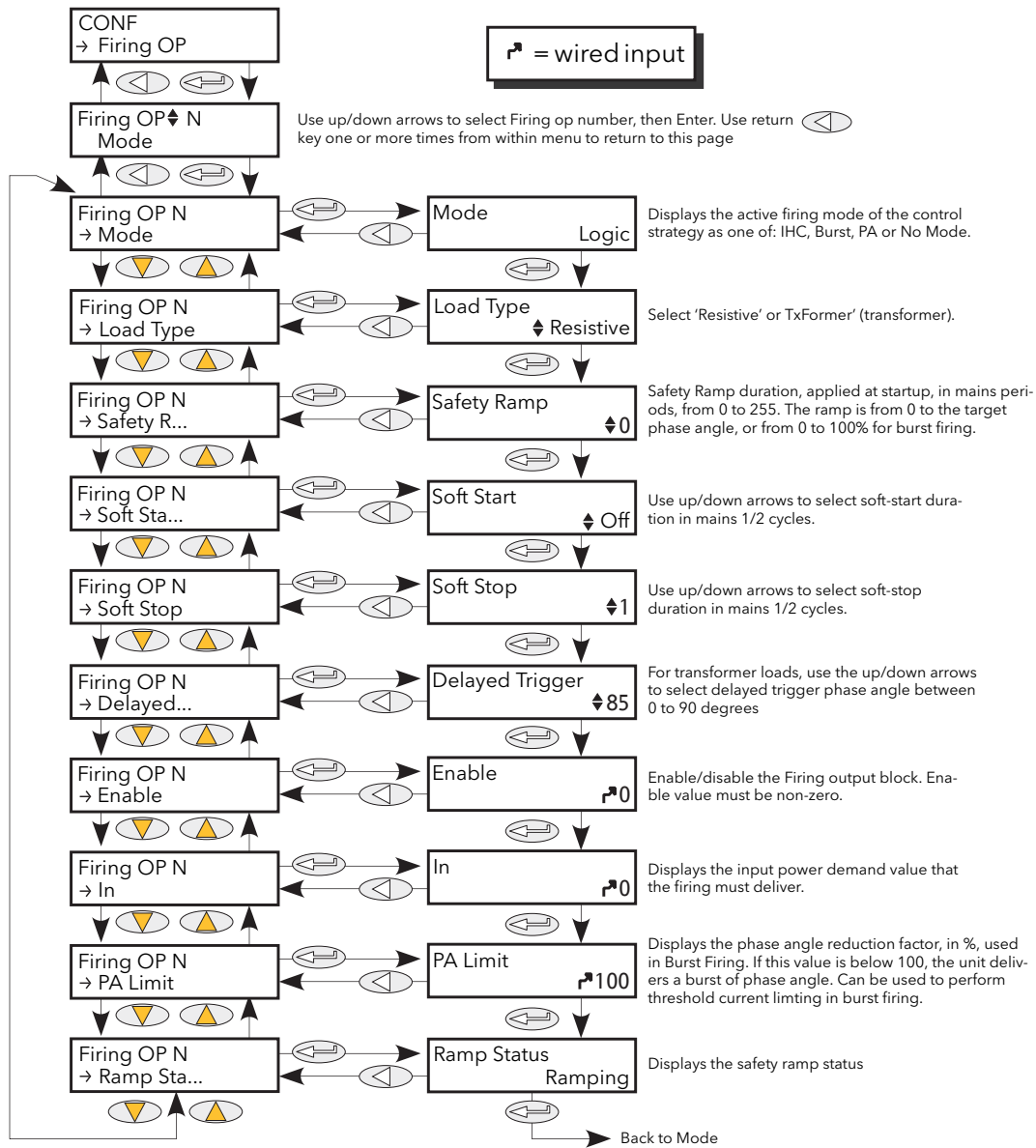

Figure 6.13a Configuration firing Output

- Mode Displays the current firing mode as Intelligent half cycle (IHC), Burst firing, Phase angle firing or no mode. Configured in the 'Modultr', menu described below.
- Load Type Allows the load type to be selected as 'Resistive' or 'Transformer'. For Load type = Resistive, the load must be connected directly to the power module and only resistive loads may be so connected. For Load Type = Transformer, the load is connected to the power module via a transformer, and may be resistive or reactive.

6.13 FIRING OUTPUT (Cont.)

Safety Ramp	Displays the safety ramp duration, in supply voltage cycles (0 to 255), to be applied at startup. The ramp is either a phase angle ramp from zero to the requested target phase angle or, for Burst Firing, from 0 to 100%. See figure 6.13b. Safety Ramp is not applicable to Half cycle Mode.
Soft Start	For Burst Firing only, this is the soft start duration, in supply voltage 1/2 cycles, applying a phase angle ramp at the beginning of each on period. (Figure 6.13c).
Soft Stop	In Burst Firing, the soft stop duration, in supply voltage 1/2 cycles, applying a phase angle ramp at the end of each on period.
Delayed Trigger	Appears only if Mode = Burst, Soft Start = Off, and Load Type = TxFormer. Delayed Trigger specifies the triggering delay, in phase angle, when delivering power into a transformer load. Used to ensure that the thyristor is fired when the current is zero. Configurable between 0 and 90 degrees inclusive. See figure 6.13d.
Enable	Enables/disables firing. Must be wired to a non-zero value to enable firing (typically a digital input).
In	Displays the input power demand value that the power module is to deliver.
PA Limit	Phase angle limit. This is a phase angle reduction factor used in Burst Firing. If lower than 100% the power module will deliver a burst of phase angle firing. Used, typically, to perform threshold current limiting in Burst Firing.
Ramp Status	Displays the safety ramp status as 'Ramping' or 'Finished'.

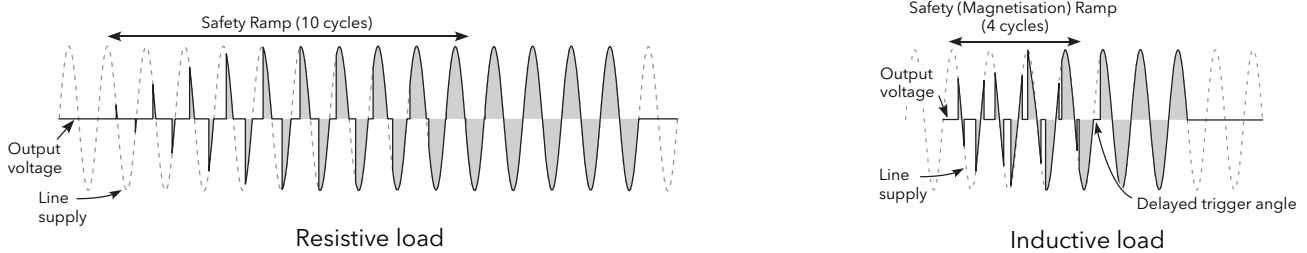

Figure 6.13b Safety ramp (burst firing) examples

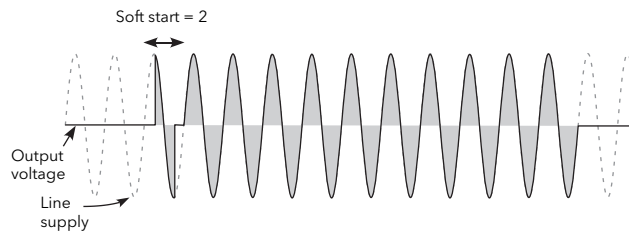

Figure 6.13c Soft start example

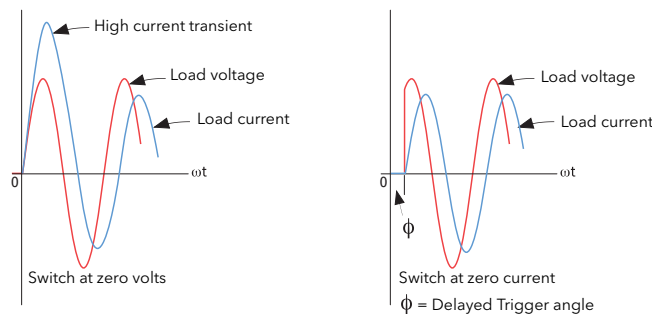

Figure 6.13d Delayed trigger definition

Note: Waveforms have been idealised for clarity

6.14 INSTRUMENT MENU

Allows the user to select the display language, and to view the unit's Serial number and the current Network configuration.

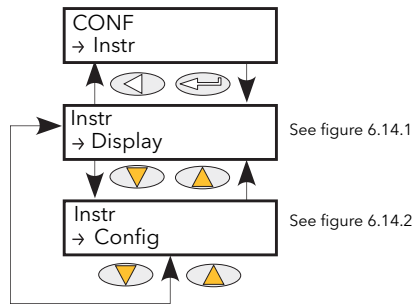

Figure 6.14 Instrument menu

6.14.1 Instrument Display parameters

Allows the user to select display language and to view the unit's serial number.

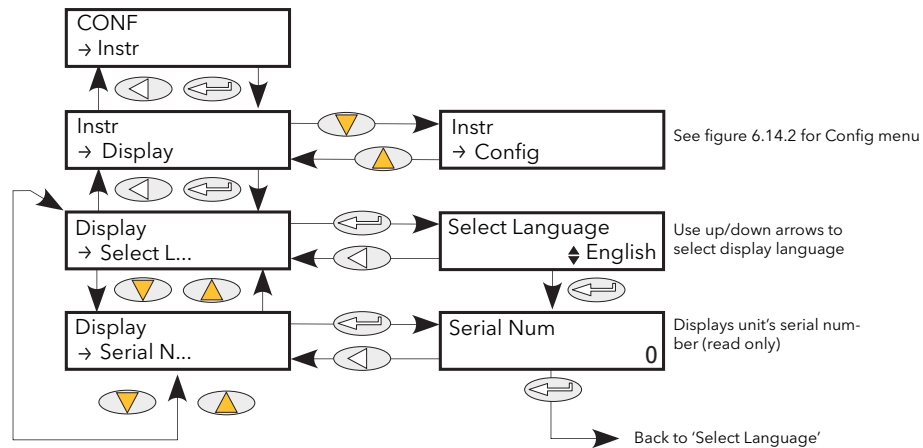

Figure 6.14.1 Instrument Display submenu

Serial Num
Select Language

Read only. Displays the factory-set Serial number of the unit.
The up and down arrow keys are used to select the required language from English, French, German or Italian. (Correct at time of writing - further languages may be added during the life of this manual.)

6.14.2 Instrument Config parameters

Allows the user access to the current power network configuration.

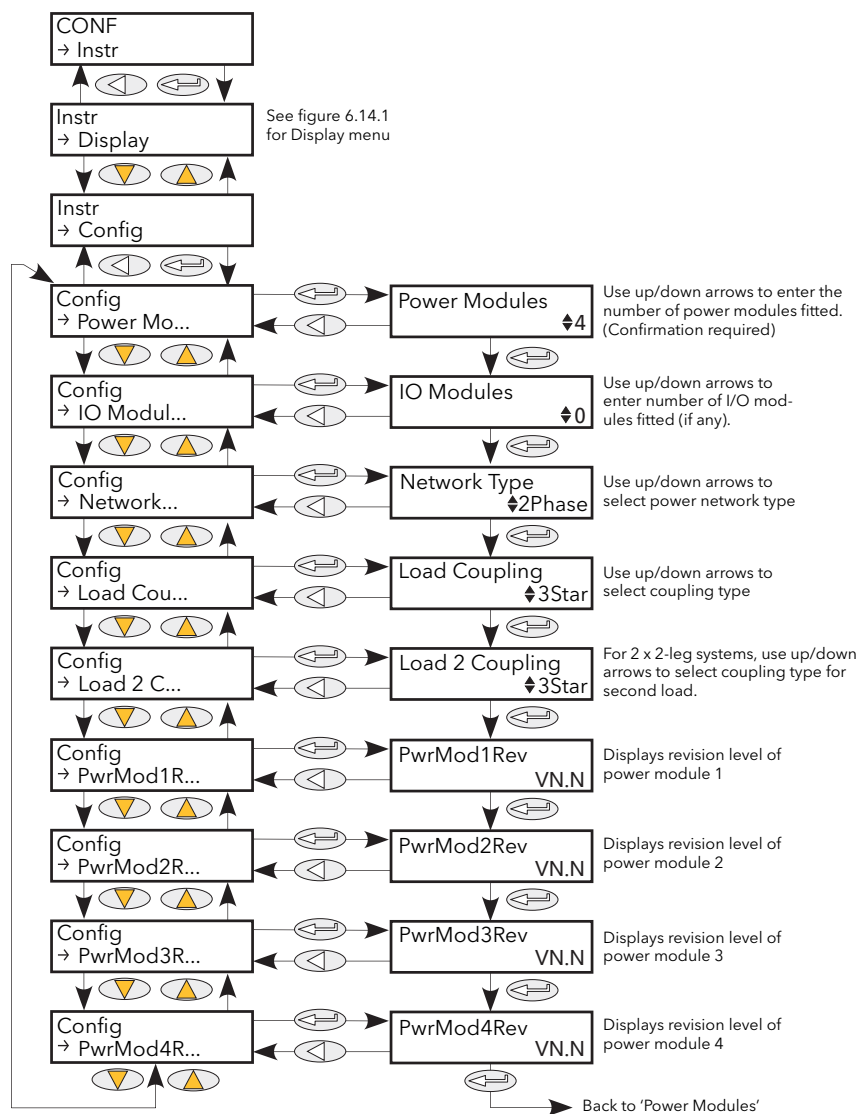

Figure 6.14.2 Instrument Config submenu

Power Modules	Configures the number of power modules fitted. If left at zero, the system automatically determines the number of modules fitted and sets the parameter accordingly.
IO Modules	Specifies the number of optional I/O modules fitted. If left at zero, the system automatically determines the number of modules fitted and sets the parameter accordingly.
Network Type	Selects the type of network to be used, from 3 Phase, Single Phase or 2 Phase.
Load Coupling	For a three-phase system this allows the user to select the wiring configuration from 3Star, 3Delta, 4Star or 6Delta. For a two-phase system, only 3Delta or 3Star is selectable.
Load 2 Coupling	As Load Coupling, above, but for the second load in 2 x 2-leg systems.
PwrMod1Rev	Shows the revision level of power module '1'.
PwrMod2Rev	Shows the revision level of power module '2'.
PwrMod3Rev	Shows the revision level of power module '3'.
PwrMod4Rev	Shows the revision level of power module '4'.

6.15 IP MONITOR MENU

This monitors a wired parameter and records its maximum value, minimum value and the cumulative time that its value spends above a configurable threshold. An alarm can be set up to become active when the time-over-threshold exceeds a further threshold.

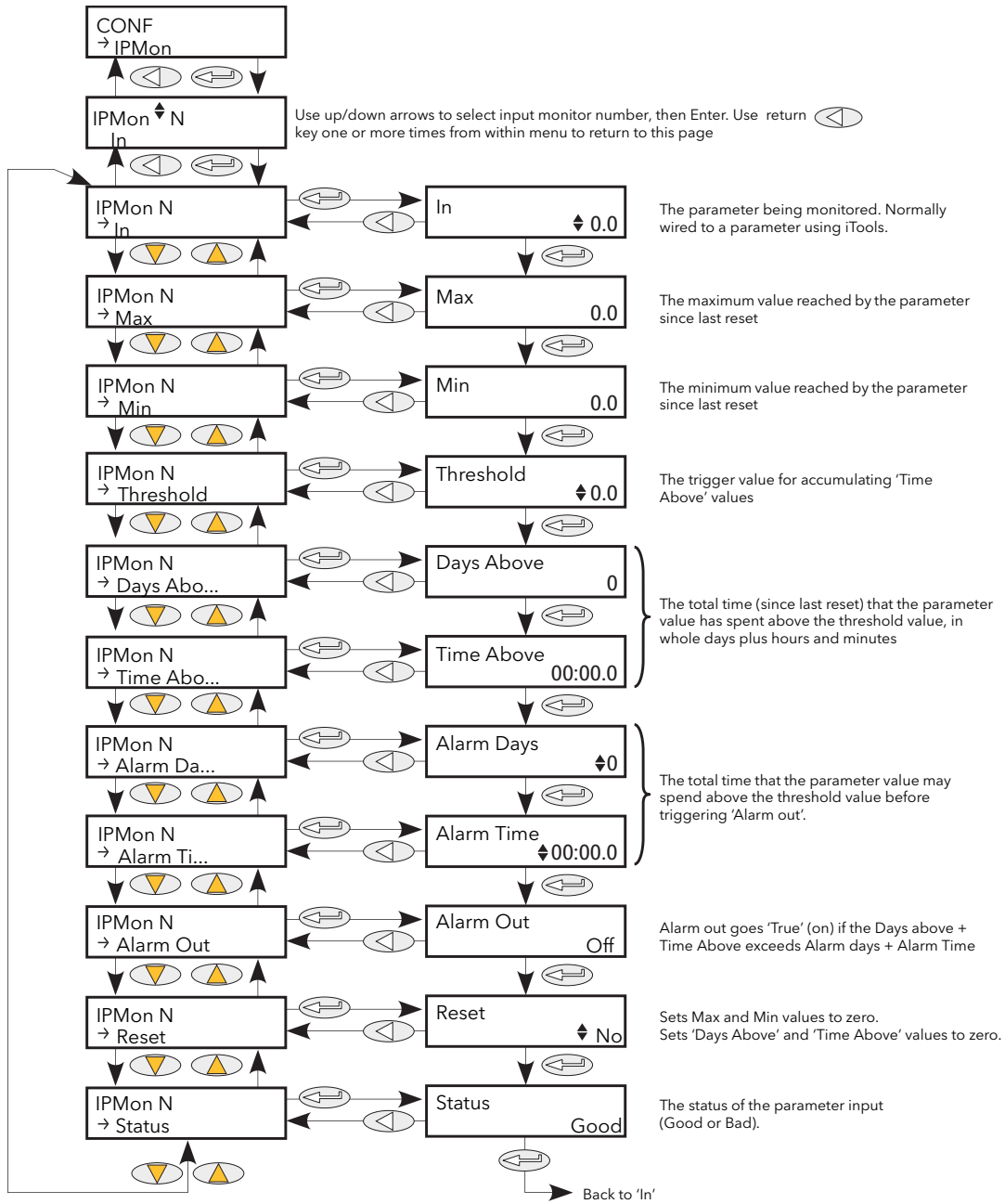

Figure 6.15 IP Monitor menu

6.15 IP MONITOR MENU (Cont.)

In	The parameter to be monitored. Normally wired (using iTools) to a parameter, but a numeric entry can be made for testing purposes.
Max	The maximum value reached by the parameter since last reset.
Min	The minimum value reached by the parameter since last reset
Threshold	This value acts as a trigger for the 'Time Above' measurement.
Days above	Shows how many complete days the parameter value has spent above the Threshold value (continuously or intermittently) since last reset. The 'Time Above' value should be added to 'Days Above' in order to find the total time.
Time Above	Shows how many hours, minutes and tenths of minutes that the parameter value has spent above the threshold value (continuously or intermittently) since last reset, or since the last complete day. (once the value exceeds 23:59.9, it increments the 'Days Above' value and resets itself to 00:00.0.) The 'Time Above' value should be added to 'Days Above' in order to find the total time.
Alarm Days	Together with 'Alarm Time' this defines a 'total time above threshold' value, which, when exceeded, sets the Alarm out parameter 'On'.
Alarm Time	See 'Alarm Days' above.
Reset	Resetting causes the Max. and Min. values to be set to the current value, sets the 'Days Above' value to zero, and the 'Time Above' value to 00:00.0.
Status	Shows the status of the input parameter as either 'Good' or 'Bad'.

6.16 LGC2 (TWO INPUT LOGIC OPERATOR) MENU

This logic operator block provides a number of two-input logic operations. The output is always a 'Boolean' (logic 0 or 1) no matter whether the inputs are analogue or digital. For analogue inputs, any value below 0.5 is deemed to be logic 0 (off). A value equal to or greater than 0.5 is treated as a logic 1 (on).

Either input can be 'inverted' as a part of the configuration (that is, a high input is treated as a low input and vice-versa.)

Figure 6.16 shows the LGC2 menu.

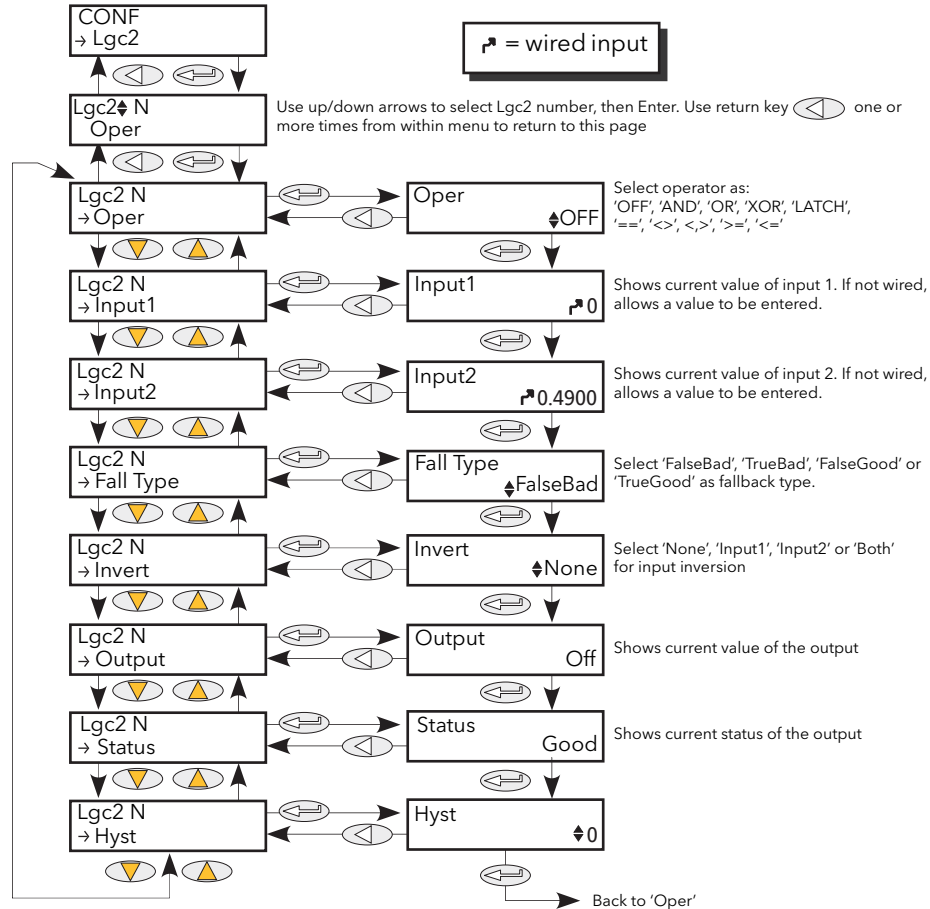

Figure 6.16 LGC2 menu

6.16.1 Lgc2 Parameters

Oper	Allows the user to select a logic operation for the block. The descriptions below assume neither input is inverted. High = 1 or on; Low = 0 or off.
Off	No logic operation selected.
AND	Output high if both inputs high, otherwise output is low.
OR	Output high if either or both inputs high, otherwise output low.
XOR	Output high if either (but not both) inputs high. Low if neither or both inputs high.
LATCH	If i/p2 low, output latches next transition of i/p1. Value remains latched until i/p2 goes low, when output = i/p1 (see figure 6.16.1).
==	Output high if both inputs are equal, otherwise output is low.
<>	Output high if inputs are unequal. Output is low if both inputs are equal.
>	Output high if i/p1 value greater than i/p2 value, otherwise output is low.
<	Output high if i/p1 value less than i/p2 value, otherwise output is low.
>=	Output high if i/p1 value is equal to or greater than i/p2 value, otherwise output is low.
<=	Output high if i/p1 value is less than or equal to i/p2 value, otherwise output is low.

6.16.1 LGC2 PARAMETERS (Cont.)

Input 1	If wired, shows the value of input 1; if not, allows the user to enter a value.
Input 2	If wired, shows the value of input 1; if not, allows the user to enter a value.
Fall type	Allows a fallback type to be selected. This defines the output value and status displays if the status of one or both inputs is 'bad'.
FalseGood	Output value displays 'False' ; Status displays 'Good'
FalseBad	Output value displays 'False' ; Status displays 'Bad'
TrueGood	Output value displays 'True' ; Status displays 'Good'
TrueBad	Output value displays 'True' ; Status displays 'Bad'
Invert	Allows none, either or both inputs to be inverted.
Output	Shows the current output value
Status	Shows the status of the output ('Good' or 'Bad').
Hysteresis	For comparison operators only (e.g. >) this allows a hysteresis value to be entered. For example, if the operator is '>' and hysteresis is H, then the output goes high when input 1 exceeds input 2, and remains high until input 1 falls to a value less than (Input 2 - H). Not applicable to the '==' (equals) function.

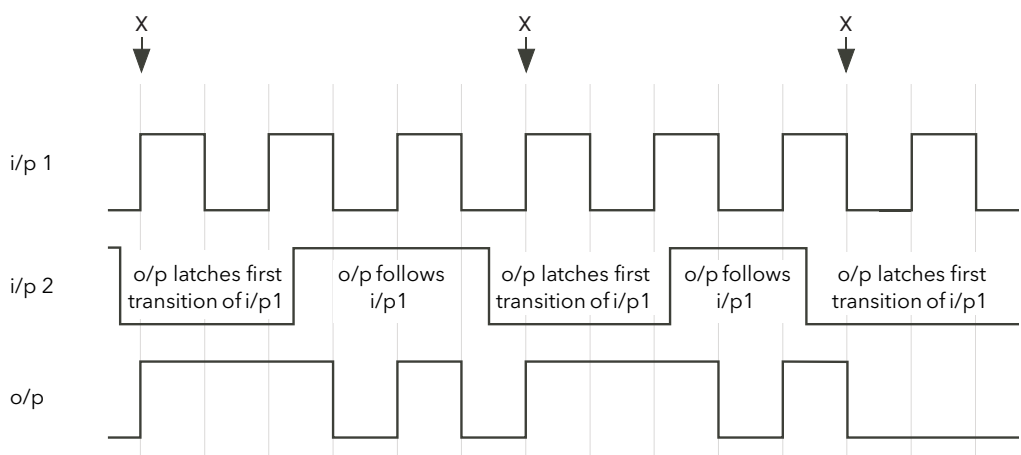
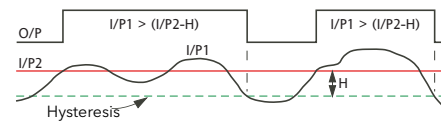

When i/p2 goes low, o/p follows the next positive or negative transition of i/p 1 (points 'X') and latches at this value until i/p2 goes high. When i/p2 is high, o/p follows i/p1.

Figure 6.16.1 Latch operation

6.17 LGC8 (EIGHT-INPUT LOGIC OPERATOR) MENU

This allows between 2 and 8 inputs to be combined using an AND, OR or Exclusive OR (EXOR) logic function. The inputs may be individually inverted, and the output can also be inverted, thus allowing the full range of logic functions to be implemented.

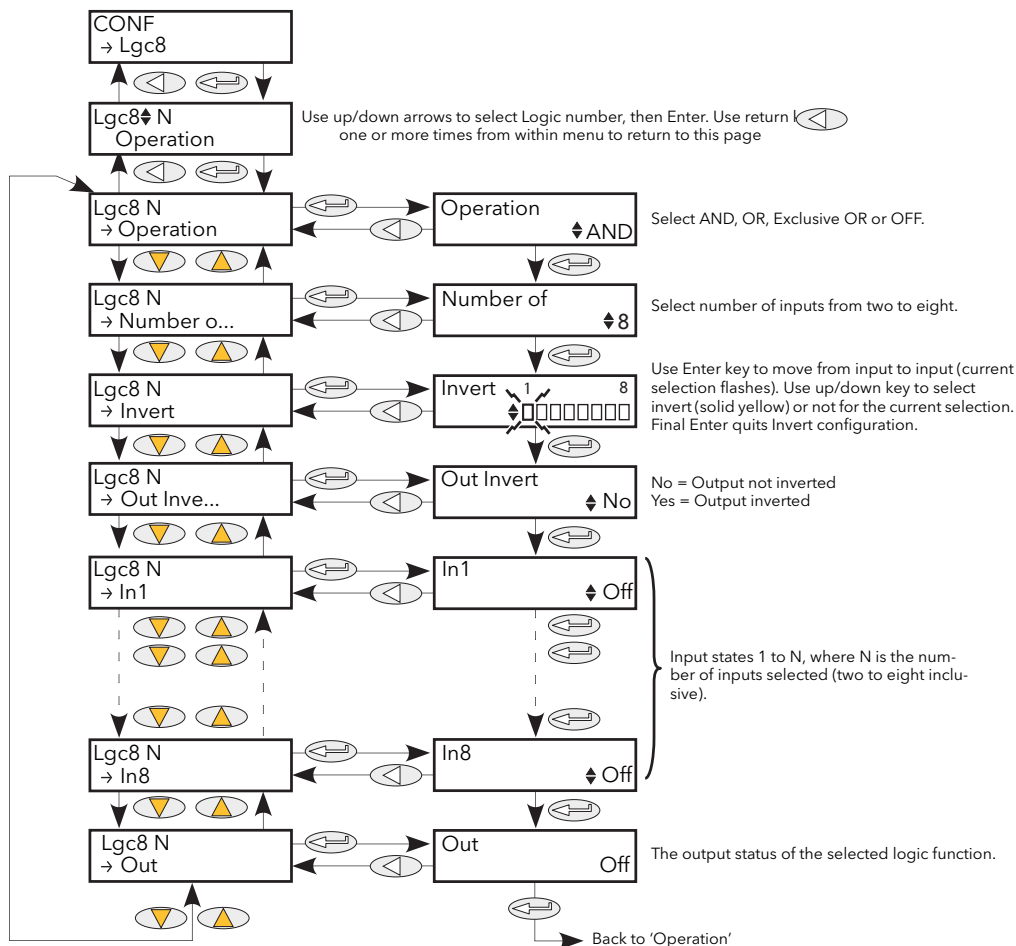

Figure 6.17 Lgc8 Menu

- Operation** Allows selection of AND, OR or Exclusive OR functions (or OFF).
 AND = output is high only if all inputs are high
 OR = output is high if any or all inputs are high
 XOR = output is high if an odd number of inputs are high, and low if an even number of inputs are high. Logically, a cascaded XOR function: (((((((In1 ⊕ In 2) ⊕ In 3) ⊕ In 4)... ⊕ In 8)
- Number of inputs** Set the number of inputs to between two and eight inclusive. This number defines how many invert keys appear in 'Invert', and how many Input value pages appear.
- Invert** Between two and eight piano keys appear (according to the number of inputs selected) at the bottom line of the display, with the left-most one (input 1) flashing. The up or down arrow can be used to select 'invert' for this input (key goes solid yellow), and/or the 'Enter' key can be used to move to the next input. Once all the inputs have been accessed, the final operation of the Enter key quits the Invert configuration, and 'output invert' is entered.
- Out Invert** No = normal output; 'Yes' means that the output is inverted, allowing NAND and NOR functions to be implemented.
- In1** The state (on or off) of the first input
- In2 onwards** The state of the remaining inputs
- Out** The Output value of the function (i.e. On or Off)

6.18 MATH2 MENU

This feature allows a range of two-input mathematical functions to be performed. The available functions are listed below.

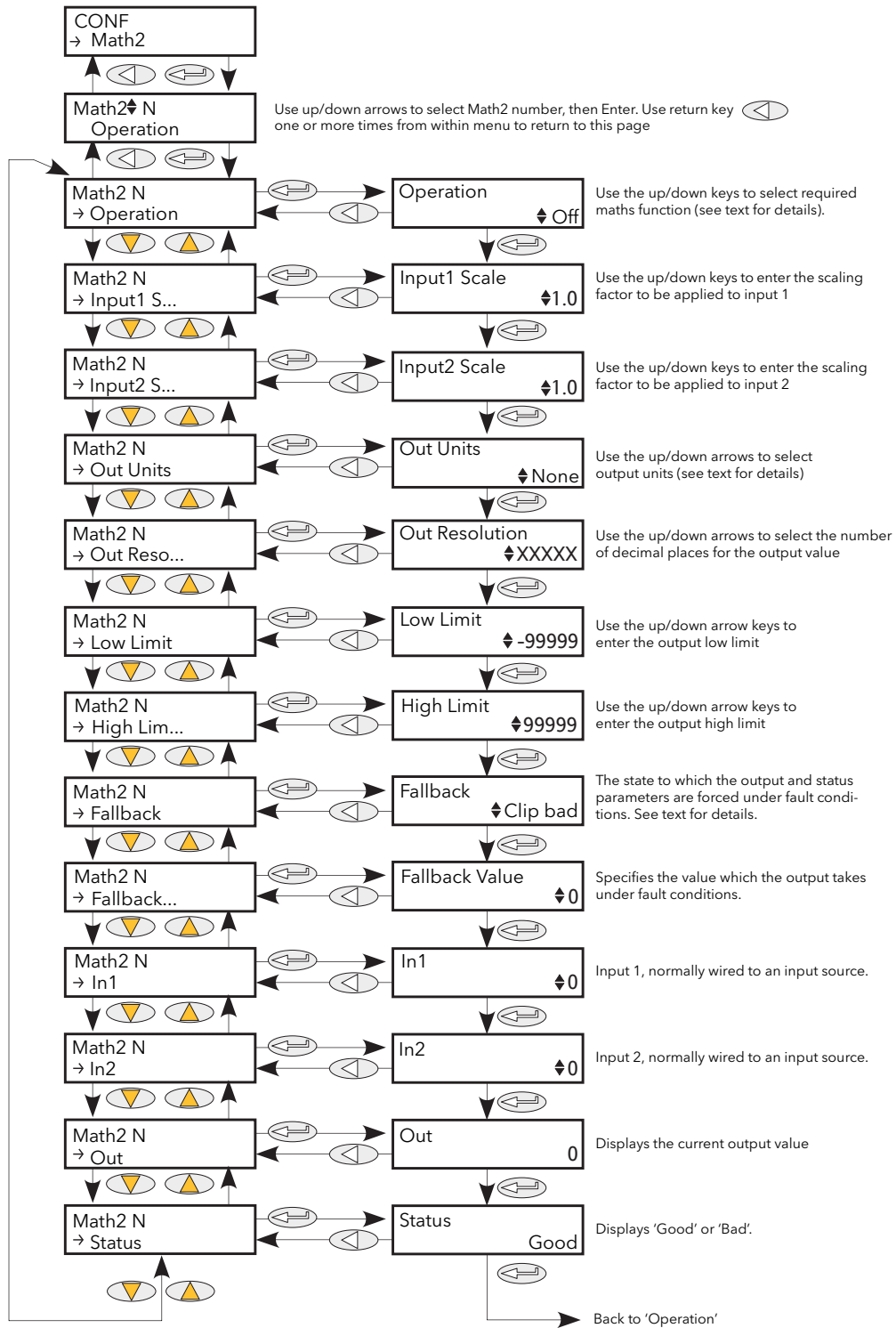

Figure 6.18 Analogue maths functions menu

6.18 MATH2 MENU (Cont.)

Note: For the sake of this description, 'High', '1' and 'True' are synonymous, as are 'Low', '0' and 'False'.

Operation	Defines the mathematical function to be applied to the inputs:
None	No operation.
Add	Adds input one to input two.
Sub	Subtracts input two from input one.
Mul	Multiplies inputs one and two together.
Div	Divides input one by input two.
AbsDif	The difference in value between inputs one and two, ignoring sign.
SelMax	Output = the higher of inputs one and two.
SelMin	Output = the lower of inputs one and two.
HotSwp	Input one appears as the output for as long as input one is 'good'. If input one status is bad, input two appears as the output instead.
SmpHld	Sample and Hold. The output follows input one, for as long as input two is high (sample). When input two goes low (hold), the output is held, at the value current when the output went low, until input two goes high again. Input two is normally a digital value (low = 0 or high =1); when it is an analogue value, then any positive non-zero value is interpreted as a high.
Power	Output = Input one raised to the power of input two ($In1^{In2}$). For example if input one has the value 4.2, and the value of input two is 3, then output = $4.2^3 = 74.09$.
Sqrt	The output is the square root of input one. Input two is not used.
Log	Output = Log_{10} (input one). (Log base 10). Input two is not used.
Ln	Output = Log_e (input one). (Log base e). Input two is not used.
Exp	Output = $e^{(\text{input one})}$. Input two is not used.
10 x	Output = $10^{(\text{input one})}$. Input two is not used.
Select	If the Select input is high, input two appears at the output; if the Select input is low, input one appears at the output.
Input1 Scale	The scaling factor to be applied to input one.
Input2 Scale	The scaling factor to be applied to input two.
Out Units	Allows the user to choose units for the output.
Out Resolution	Use the up and down arrows to position the decimal point as required.
Low Limit	The low limit for all inputs to the function and for the fallback value.
High Limit	The high limit for all inputs to the function and for the fallback value.
Fallback	The fallback strategy comes into play if the status of the input value is 'Bad', or if its value lies outside the range (High limit- Low limit). Fall Good: The output is set to the fallback value (below); output status is set to 'Good'. Fall Bad: The output is set to the fallback value (below); output status is set to 'Bad'. Clip Good: The output is set to the high or low limit as appropriate; output status is set to 'Good'. Clip bad: The output is set to the high or low limit as appropriate; output status is set to 'Bad'. DownScale: The output is set to the low limit and Status is set to 'Bad'. Upscale: The output is set to the high limit and Status is set to 'Bad'.
Fallback value	Allows the user to enter the value to which the output is set for Fallback = Fall Good, or Fall Bad.
Select	Appears only if Operation = Select. Allows input one or input two to be selected for output.
In1	Input one value (normally wired to an input source).
In2	Input two value (normally wired to an input source).
Out	The output value resulting from the configured mathematical operation. If either input is 'Bad', or if the result is out of range, the fallback strategy is adopted.
Status	Indicates the status of the operation as 'Good' or 'Bad'. Used to flag error conditions and can be used as an interlock for other operations.

6.19 MODULATOR MENU

This function implements the modulation type firing modes such as fixed and variable period modulation.

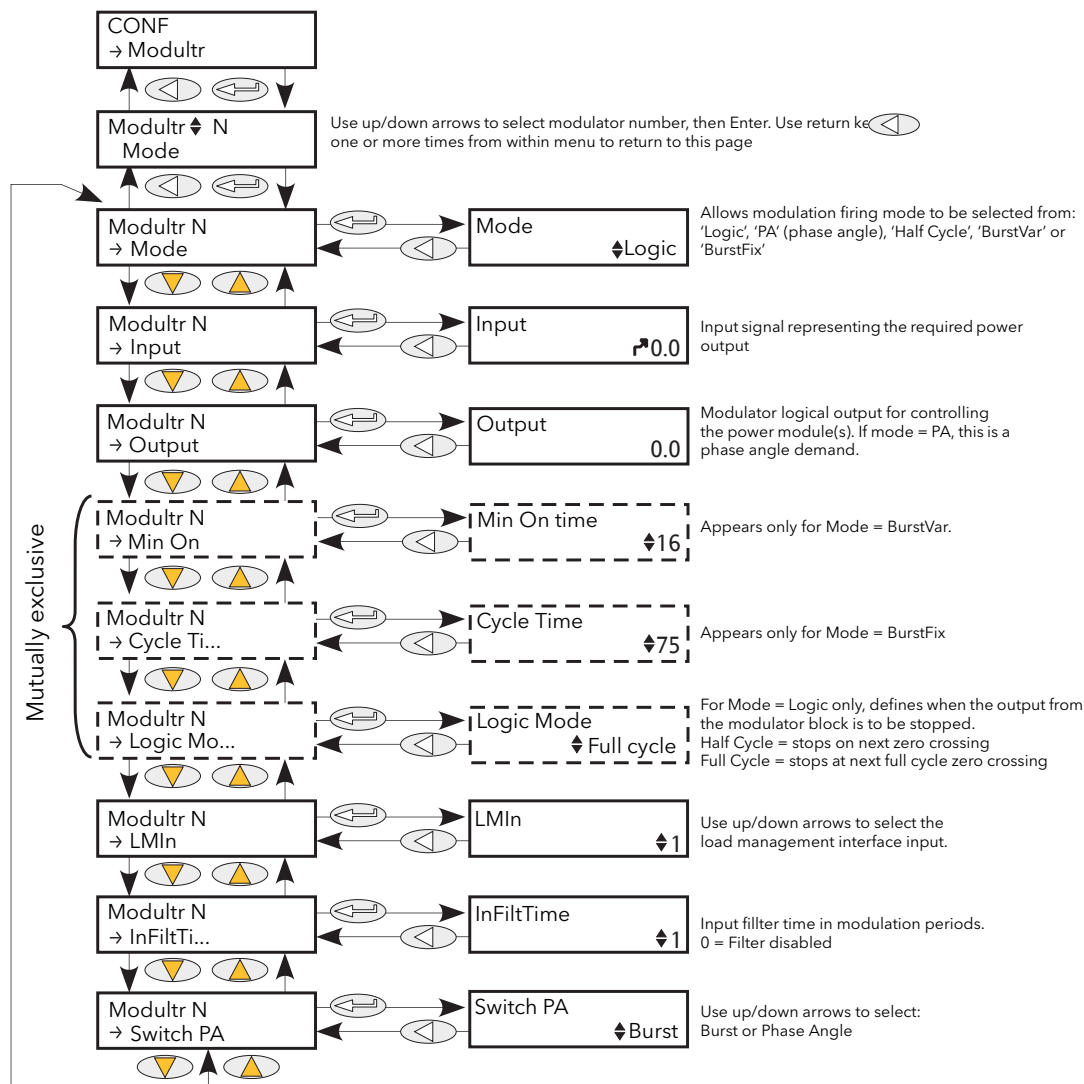

Figure 6.19 Modulator menu

Mode	Select the required firing mode from "Logic", 'PA' (Phase angle) 'Half cycle', 'BurstVar' (Burst firing - minimum on time) or 'BurstFix' (Burst firing - cycle time).
Input	This is the value that the modulator is required to deliver.
Output	The output logic signal controlling the power module on and off times, normally wired to the input of the firing block. For Mode = Phase angle, this is a phase angle demand.
Min on Time	For Variable Period Modulation, this sets the minimum on time in supply voltage periods. At 50% demand from the modulator, Ton = Toff = Minimum on time, and Cycle time is 2 x Minimum on time = Modulation period. The minimum off time is equal to 'Min on time'.
Cycle Time	For Fixed Period Modulation, this is the cycle time in supply voltage periods.
Logic Mode	For Logic Firing Modulation, Half cycle sets firing stop to the next zero crossing; Full cycle sets firing stop at the zero crossing of the next full cycle.
LMIn	Load Management Interface input. Defines a connection from the modulator to a load management channel (if fitted).
InFiltTime	Modulator input filter time as a number of modulation periods. When set to zero, filter is disabled.
Switch PA	Allows the user to impose Phase Angle firing, overriding the configured Burst Mode as displayed in 'Mode', above.

6.20 NETWORK MENU

This identifies the type of electrical network to be controlled, and this, in turn defines how the network's electrical measurements are presented. The configuration is related to a power channel, not necessarily the Power Module number. For a network of four single-phase units, four network blocks are required; for two leg control of a three-phase network, two network blocks are used; for three-phase control of a single network, one Network block is required.

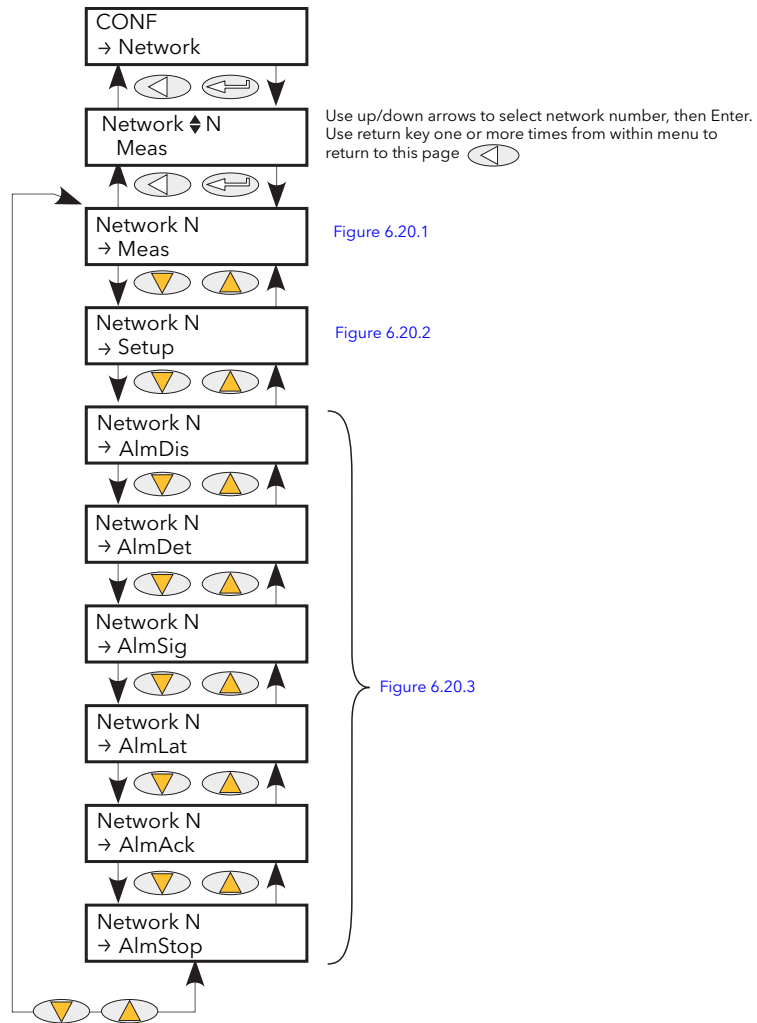

Figure 6.20 Network menu

6.20.1 Meas submenu



Figure 6.20.1 Meas submenu layout

6.20.1 MEAS SUBMENU (Cont.)

This submenu presents power network measurements, according to the network type. All available measurements are listed below, but which values actually appear depends on the network configuration.

Frequency	Displays the calculated frequency of the supply voltage of the power channel associated with this network.
Vline	Supply voltage measurement on the primary power module. Displays line to neutral except in three phase or two-leg control when line to line voltage is displayed.
Vline2, Vline 3	As for VLine but for power modules two and three respectively
I	Load Irms measurement on primary power module. The time base measurement is the main period in Phase Angle, and the modulation period in Burst Mode.
I2, I3	As for I, above, but for power modules two and three respectively.
I Average	This is the average of the current in the three channels of a three-phase system. This is relevant only for 3 phase and 2 leg controlled systems:- $I_{RMS}Avg = (I_{RMS} + I_{RMS2} + I_{RMS3})/3$
I ² Burst	Average square value of load current in burst firing. The average Isq during the burst firing, the average is taken over the duration of the burst period. This is typically used for monitoring and alarming over the burst period.
I ²	Square value of load current in Burst Firing and over the main period in phase angle. Typically used for Isq control. In 3-phase or 2-leg control this is the average of the three network squared currents, calculated as $I^2 = (I^2Phase1 + I^2Phase2 + I^2Phase3)/3$
I ² Maxim...	In a three-phase network, this is the maximum of I ² , I2 ² and I3 ² . Used in current limiting in three-phase networks, and in alarm strategies.
Irms Max...	The RMS value of I ² Max measured over the mains period. Typically used for current limiting or current transfer in 3-phase networks, in phase angle mode.
V	Load Vrms measurement on primary power module of this channel of power control. Displays load to neutral (or to second line) except in three phases star or delta load coupling displays load1 to load2 voltage The time base measurement is the main period in phase angle, and the modulation period in burst mode.
V2, V3	As for V, but for 2nd and 3rd Power Modules respectively.
V Average	The average of the voltage in the three channels of a three-phase system. This is relevant only for three-phase and two-leg power networks $V_{RMS}Avg = (V_{RMS} + V_{RMS2} + V_{RMS3})/3$
V ² Burst	Average square value of load voltage in burst firing taken over the duration of the burst period. Typically used for monitoring and alarm strategies over the burst period.
V ²	Square value of load voltage in Burst Firing and on main period in Phase Angle Firing. Typically used for Vsq control. In three-phase or Two-leg control this is the average of the three network squared voltages, calculated as $Vsq = (VsqaPhase1 + VsqaPhase2 + VsqaPhase3)/3$
V ² Maxim...	The maximum squared voltage out of VsqaPhase1, VsqaPhase2, VsqaPhase3. Typically used for voltage limiting in three-phase networks and for alarm strategies.
Vrms Max...	The RMS value of V ² Max measured over the mains period. Typically used for voltage limiting or transfer in 3-phase networks, in phase angle mode.
P Burst	Measurement of true power on the network. This is calculated over the modulation period in Burst Firing mode. Typically used for monitoring, alarm strategy and in Load management (if option fitted).
P	True power measurement in Burst Firing and over the modulation period in Phase Angle firing. Typically used for true power control
S	Apparent power measurement. For phase angle firing $S=Vline \times I_{RMS}$; for burst firing $S=V_{RMS} \times I_{RMS}$
PF	Calculation of power factor. Defined as Power Factor = True Power / Apparent Power. In phase angle this is $PF=P/S$; in burst firing $PF = PBurst/S = Cos\phi(Load)$
Q	Calculation of the reactive power defined in phase angle as $Q = \sqrt{S^2 - P^2}$, or in burst firing as $Q = \sqrt{S^2 - P_{Burst}^2}$.
Z	Load impedance measurement on first power module, defined as:- $Z=Vrms/Irms$. Measurement uses line current (not leg current) and load voltage, so value may not be accurate for some multi-phase wiring configurations.
Z2, Z3	Load impedance measurement on the 2nd and 3rd phase of the network respectively.
HSink1(2)(3) T...	Heat sink temperatures. Used to protect the Power Modules from overheating.

6.20.2 Network Setup Submenu

This displays the setup of the network and associated functions.

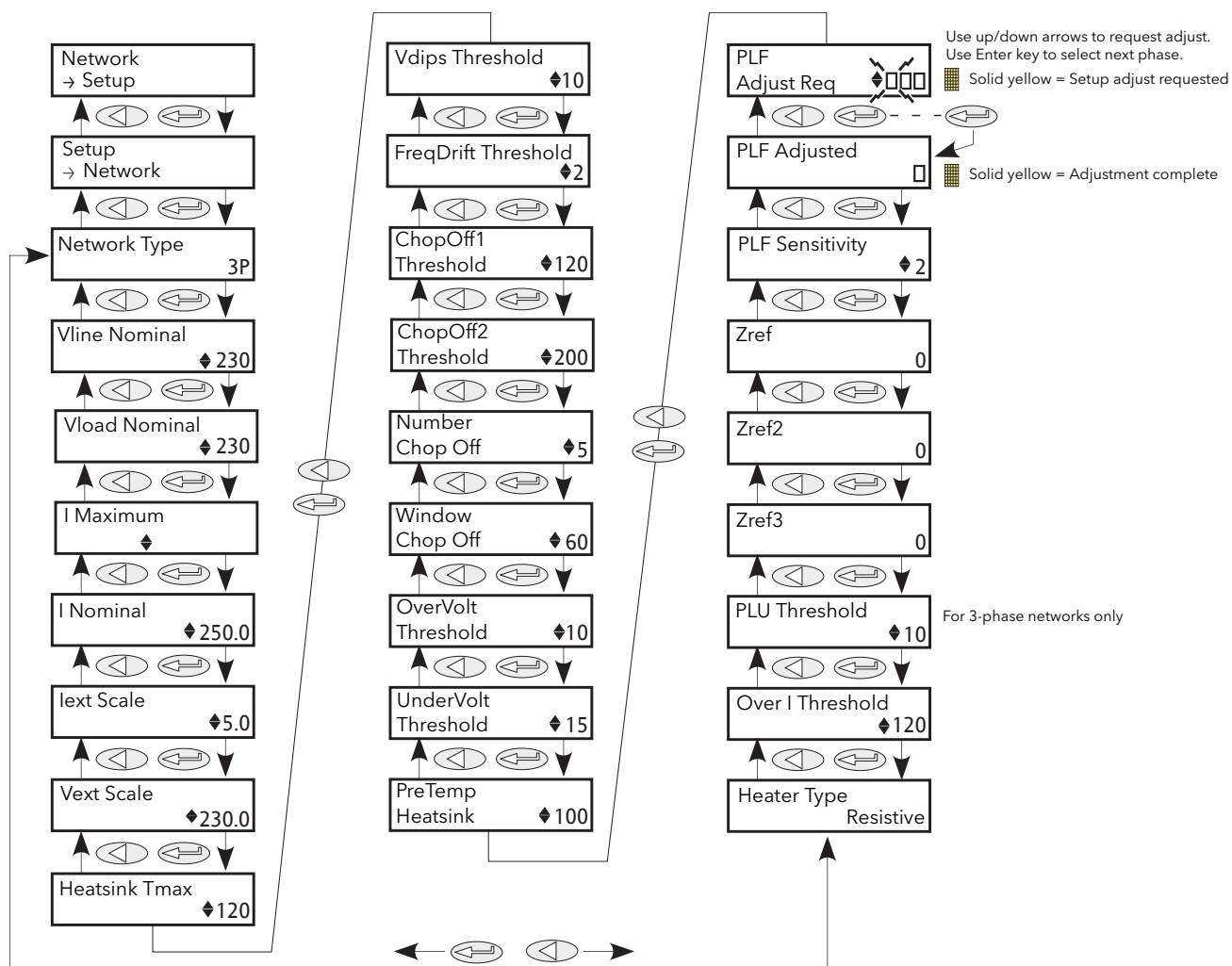

Figure 6.20.2 Network Setup submenu

Network Type	Displays the Network type as Three phase, Single phase or Two-leg control.
Vline Nominal	Line voltage nominal value required to calibrate the stack. This is the line to line voltage except for Single phase to Neutral and Three-phase Star with Neutral networks, when the measurement is line to neutral.
VloadNominal	Nominal Load voltage, required to calibrate the Power Module. This is the same as the Vline Nominal except when external feedback is used e.g. from a transformer secondary. In which case this value must be correctly set to scale the measurement.
IMaximum	Indicates the maximum current of the stack (50, 100, 160, 250, 400, 500, 630). For transformer-driven loads, select EXT100 etc. and configure IextScale appropriately.
INominal	Nominal current supplied by the Power Module. This value is used for calibrating the current measurement in the stack. This is limited by IMaximum, which imposes the limit of the physical channels unless external feedback is configured, in which case the limit is 4000A.
IextScale	External current scale adjustment for use when IMaximum is set to external feedback. If an external current transformer is fitted, IextScale should be set to the normal primary current of the current transformer. If an external current transformer is not being used, IextScale should be set to 5A.

6.20.2 NETWORK SETUP SUBMENU (Cont.)

VextScale	External voltage scale adjustment for use when IMaximum is set to external feedback. If an external transformer is fitted, VextScale should be set to the nominal primary voltage of the external transformer. If an external transformer is not fitted, VextScale should be set to Vnominal.
HeatsinkTmax	Displays the maximum permissible temperature of the heat sink. This forms an alarm threshold for the 'Heat sink Overtemperature' alarm.
VdipsThreshold	Voltage dips threshold. This is a percentage difference (relative to Vline Nominal) between 2 consecutive half cycles. Each half cycle voltage measurement is integrated and at the end of each half cycle the last 2 voltage integrals are compared.
FreqDriftThold	The supply frequency is checked every half cycle, and if the percentage change between 1/2 cycles exceeds this threshold value, a Mains Frequency System Alarm is generated. The threshold may be set to a maximum of 5% to cater for the effects of heavily inductive networks.
ChopOff1Threshold	The 'Chop-off' alarm becomes active if load current exceeds this threshold for more than five seconds. Threshold values lie between 100% and 150% of INominal.
ChopOff2Threshold	The Chop-off' alarm also becomes active if this second current threshold is exceeded more than a predefined number of times (NumberChopOff) within a predefined time period (WindowChopOff). Current threshold values lie between 100% to 350% of INominal. NumberChopOff can be set to between one and 16 (inclusive) and any value between 1 and 65535 seconds may be configured for WindowChopOff. Each time an over-current is detected, the unit stops firing, raises a 'Chop-off' condition alarm, waits for about 100ms and then restarts firing using an up-going safety ramp. The 'Chop-off' condition alarm is cleared if the unit restarts successfully after an over-current event. If NumberChopOff is reached within the WindowChopOff period, the unit stops firing and remains stopped. A chop-off state alarm is triggered, making it necessary for the user to acknowledge the chop-off state alarm before restarting firing.
NumberChopOff	Displays the number of 'Chop Off' events that can occur within the WindowChopOff period before a 'Chop Off' alarm is enabled. Used only with ChopOff2Threshold.
WindowChopOff	Displays the 'Chop Off' window in seconds. Used only with ChopOff2Threshold.
OverVoltThreshold	The threshold for detecting an over voltage condition as a percentage of VLineNominal. If Vline rises above the threshold a Mains Voltage Alarm is set (DetMainsVoltFault).
UnderVoltThreshold	This is the threshold for detecting an under voltage condition as a percentage of VLineNominal. If Vline falls below the threshold a Mains Voltage Alarm occurs (DetMainsVoltFault).
PreTempHeatsink	The threshold for the heat sink temperature pre-alarm in degrees C, which, if exceeded, causes a pre-temperature (DetPreTemp) alarm to occur.
PLFAdjustReq	Partial load failure adjustment request. To make the Partial Load Failure (PLF) alarm operate correctly, the normal steady-state condition must be known to the instrument. This is done by activating the PLF Adjust Req, for each Network, once the controlled process has achieved a steady state condition. This causes a load impedance measurement to be made which is used as a reference for detecting a partial load failure. If the load impedance measurement is successful PLFAdjusted (below) is set. The measurement fails if the load voltage (V) is below 30% of (VNominal) or the current (I) is below 30% of (INominal). The PLF alarm becomes active as setup in 'PLF Sensitivity', below.
PLFAdjusted	Partial load failure adjusted acknowledge. Indicates that the user requested a PLF adjustment and that the adjustment was successful.
PLFSensitivity	Partial load failure sensitivity. This defines how sensitive the partial load failure detection is to be as the ratio between the load impedance for a PLFadjusted load and the current impedance measurement. For example for a load of N parallel, identical elements, if the PLF Sensitivity (s) is set to 2, then a PLF alarm will occur if N/2, or more elements are broken (i.e. open circuit). If PLF Sensitivity is set to 3, then a PLF alarm occurs if N/3 or more elements are broken. If (N/s) is non-integer, then the sensitivity is rounded up. E.G. if the N = 6 and s= 4, then the alarm is triggered if 2 or more elements are broken.

6.20.2 NETWORK SETUP SUBMENU (Cont.)

Zref	Reference load impedance for phase 1, as measured when PLF adjust is requested.
Zref2, Zref3	As for Zref but for phases 2 and 3 respectively.
PLUthreshold	Partial load unbalance threshold. Defines the threshold for detecting a partial load unbalance condition. This is only applicable to a three phase system. This occurs when the difference between the maximum and minimum current of the three phase system exceeds the threshold as a percentage of $I_{Nominal}$. The alarm can be detected between 5 and 50%.
OverIThreshold	The threshold for detecting an over current condition as a percentage of $I_{Nominal}$. If I is above the threshold a Mains Current Alarm occurs (DetoverCurrent).
HeaterType	Shows the type of heater used in the load as: 'Resistive', 'SWIR' (Short wave infra-red), 'CSi' (Silicon Carbide), 'MoSi2' (Molybdenum Disilicide).
MaxInom	Fix limit to $I_{Nominal}$

PARTIAL LOAD FAILURE CALCULATIONS

The PLF alarm detects a static increase in load impedance (low temperature coefficient loads and Short wave Infra Red heaters can be controlled by this feature).

The alarm works by comparing the reference load impedance with the actual measured load impedance. The user must set the reference impedance (by requesting PLFAdjust) and the partial load failure sensitivity.

Notes:

1. All elements are assumed to be identical and connected in parallel
 2. For three phase loads, the impedance reference can be set only if the load is balanced.
-

The impedance comparison takes place over a mains cycle (in phase angle firing) or over the burst period (for burst and logic firing). For star with neutral (4S) or open delta (6D) networks, the measured load voltage and current correspond directly to the load parameters. In these configurations the partial load failure sensitivity is limited only by measurement accuracy and element impedance inaccuracies. For star without neutral (3S) and closed delta (3D) configurations, equivalent impedances are calculated using line-to-line voltages and line currents, this resulting in minor inaccuracies.

Special care must be taken for short burst firing modes (e.g. IHC or single cycle firing) if no phase rotation is applied for Burst start (suppression of DC component in current transformers) and for logic firing without DC component suppression feature, for the same reason.

A minimum voltage of 30% of nominal adjusted value ($V_{load\ nominal}$) and a minimum of 30% of $I_{Nominal}$ must be applied to the load, as below these thresholds, no partial load failure detection or impedance reference setting takes place.

6.20.3 Network alarms

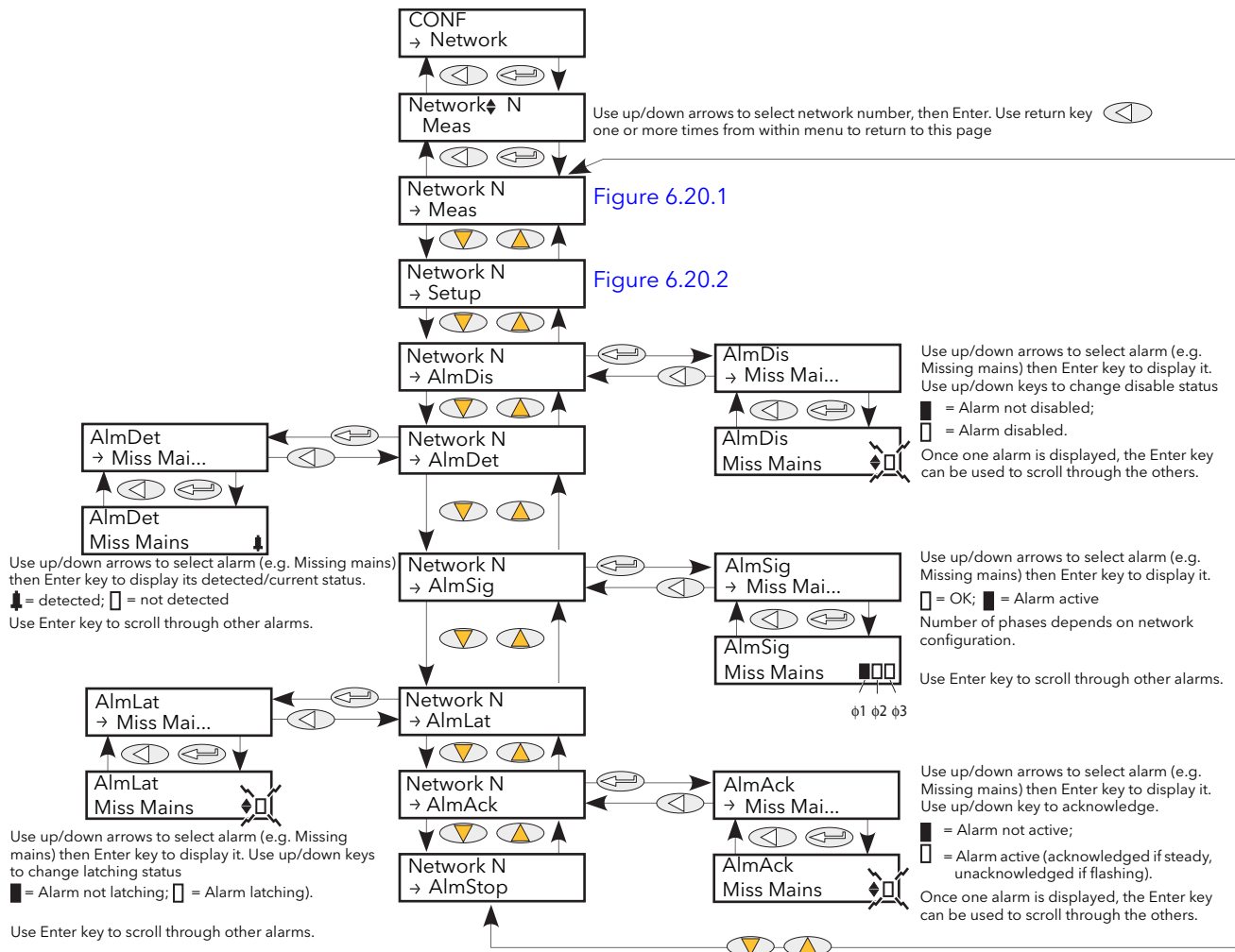

Figure 6.20.3 Network alarm menu

NETWORK ALMDIS SUBMENU

This menu allows individual network block alarms (listed below) to be enabled/disabled. Section 10 gives more details of these alarms.

MissMains	Missing Mains
Thyr SC	Thyristor Short Circuit
Open Thyr	Thyristor open Circuit
Fuse Blown	Fuse Blown
Over Temp	Over Temperature
Volt Dips	Mains Voltage Dips
Freq Fault	Frequency Fault
PB 24V	Power Board 24V Failure
TLF	Total Load Failure
Chop Off	Chop Off
PLF	Partial Load Failure
PLU	Partial Load Unbalance
VoltFault	Mains Voltage Fault
PreTemp	Pre-Temperature
Over I	Over Current

6.20.3 NETWORK ALARMS (Cont.)

NETWORK ALMDET SUBMENU

As for 'Alarm Disable', above, but this Alarm detect submenu indicates whether any of the network alarms has been detected and is currently active.

NETWORK ALMSIG SUBMENU

These displays show whether an alarm has occurred and also contains latching information. The relevant AlarmSig parameter is used when wiring (to a relay for example). The alarm list is as given above.

NETWORK ALMLAT SUBMENU

As for 'Alarm Disable', above, but this Alarm Latch submenu allows each individual network block alarm to be defined as latching or non-latching.

NETWORK ALMACK SUBMENU

As for 'Alarm Disable', above, but this Alarm Acknowledge submenu allows each individual network block alarm to be acknowledged. Once acknowledged, the associated signalling parameter is cleared. Acknowledge parameters automatically clear after being written.

Note: Alarms may not be acknowledged whilst the trigger source is still active.

NETWORK ALMSTOP SUBMENU

Allows each individual alarm type to be configured to stop the related power module from firing. Activated by the related Signalling parameter. The alarm list is as given above.

6.21 PLM (STATION AND NETWORK LM PARAMETERS) MENU

This menu appears only if the Predictive Load Management option is fitted and enabled.

LoadMng provides an interface to the parameters of the station and of the load management network. A 'station' is defined as a Driver module and associated power modules. Figure 6.21 gives an overview of the menu.

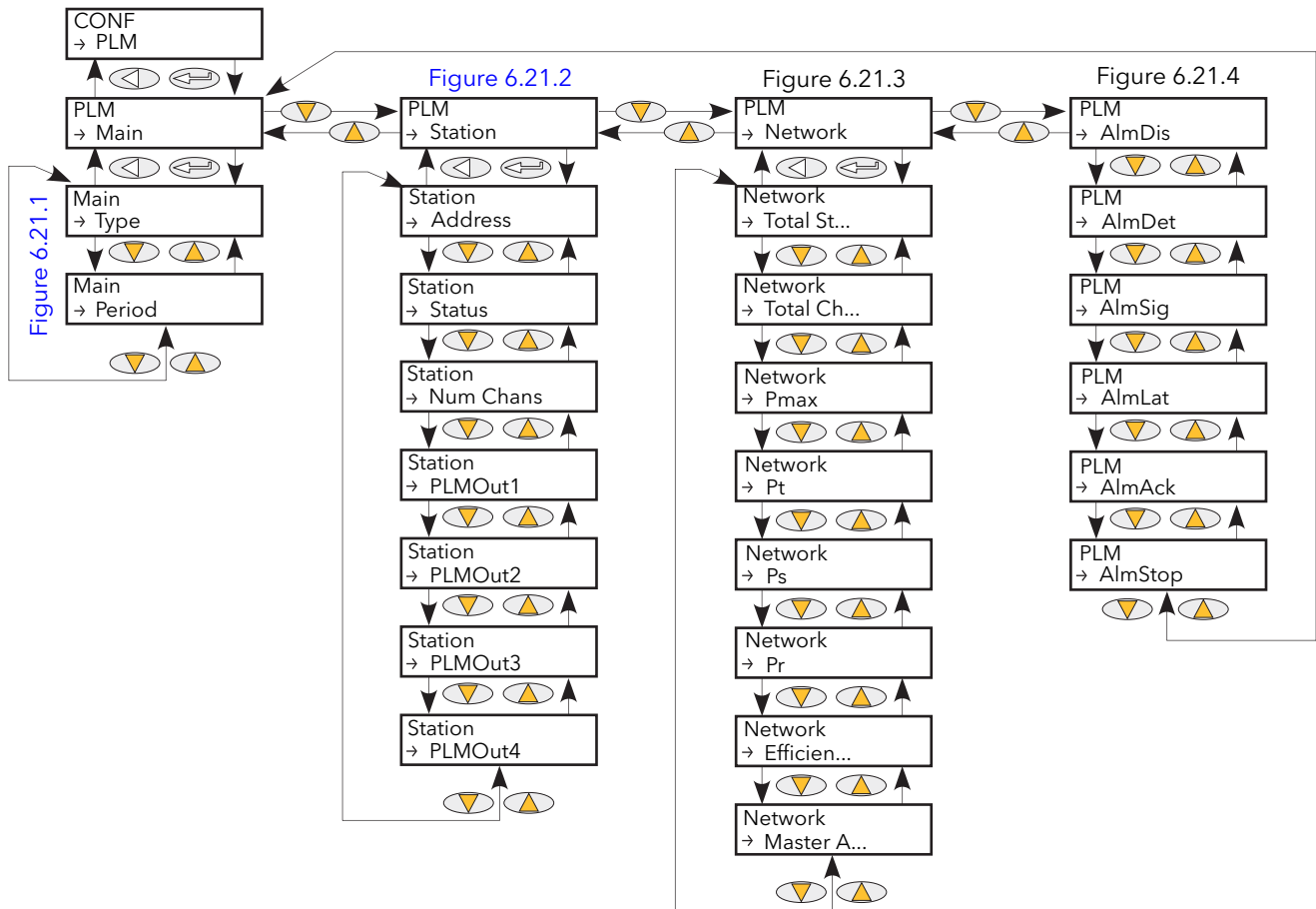

Figure 6.21 Predictive Load Management Menu overview

6.21.1 Main

This presents the main Load Management parameters.

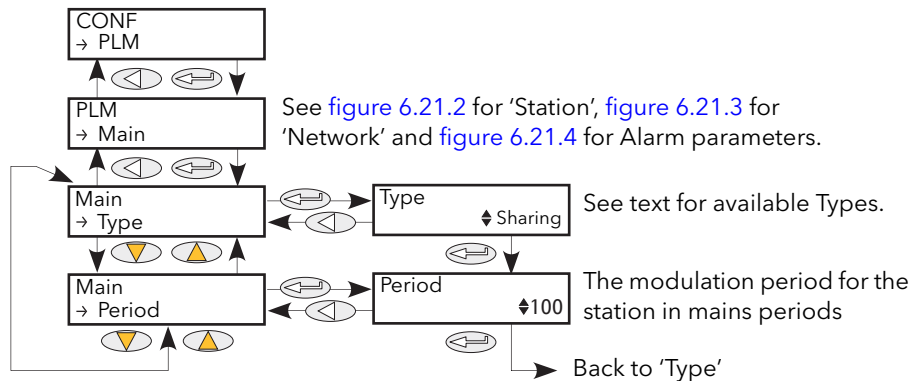

Figure 6.21.1 Load Management 'Main' menu

6.21.1 PREDICTIVE LOAD MANAGEMENT 'MAIN' MENU (Cont.)

Type	<p>Configures the type of Predictive Load Management as follows:</p> <p>No: No Load Management. Load Management is disabled.</p> <p>Sharing: Load Sharing. Used to control the total power demand over time by distributing the conduction periods of the various units.</p> <p>IncrT1: Incremental Type 1. Several loads receive a common setpoint. Only one channel is modulated by the duty cycle, the others being at 0% or 100% demand. Total power distributed = setpoint value.</p> <p>IncrT2: Incremental Type 2. A number of loads receive a common setpoint. Only the first channel is modulated, by the duty cycle, the others being at 0% or 100% demand. Total power distributed = setpoint value.</p> <p>RotIncr: Rotating Incremental. Provides incremental control of between two and 64 channels, operating from a single input. Each channel modulates with an identical mark-space ratio determined by the power demand signal, but each channel is separated from adjacent outputs by the selected time base.</p> <p>Distrib: Distributed Control. This mode provides control of between two and 64 channels from an equal number of independent inputs. Each channel modulates with a mark-space ratio proportional to its input signal, but with the switching of adjacent inputs distributed over the selected time cycle.</p> <p>DistIncr: Distributed and Incremental control. This provides control of between two and eight groups of loads. A total of 64 channels is available, and these may be freely distributed among the groups, as long as each group has at least one channel. Each group has a single power demand input and operates as in Incremental Type 2 mode, with the first channel modulating to maintain the selected power level. Switching time within groups is distributed over the selected time cycle.</p> <p>RotDisInc: Rotating Distributed and Incremental control. This provides control of between two and eight groups of loads. A total of 64 channels is available, and these may be freely distributed among the groups, as long as each group has at least one channel. Each group has a single power demand input and operates in Rotating Incremental mode with all channels modulating at an identical rate. The distributed nature of this mode ensures that the instant of switch on in each group is distributed over the cycle time.</p>
Period	<p>This configures the modulation period for the station, in mains periods between 50 and 1000. The accuracy of control is related to the modulation period - to increase accuracy the period must be increased.</p> <p>The master unit imposes its modulation period on all slaves. It is recommended that all slave units are configured to use the same period as the master, so that should the master lose control, then the slave that replaces it as master will use the same value and thus achieve the same accuracy of control. (The new master imposes its own value at the next power cycle.)</p>

6.21.2 Predictive Load management 'Station' menu

This menu contains all parameters related to Load Management Station configuration, where a 'station' consists of a Driver Module together with its associated Power modules.

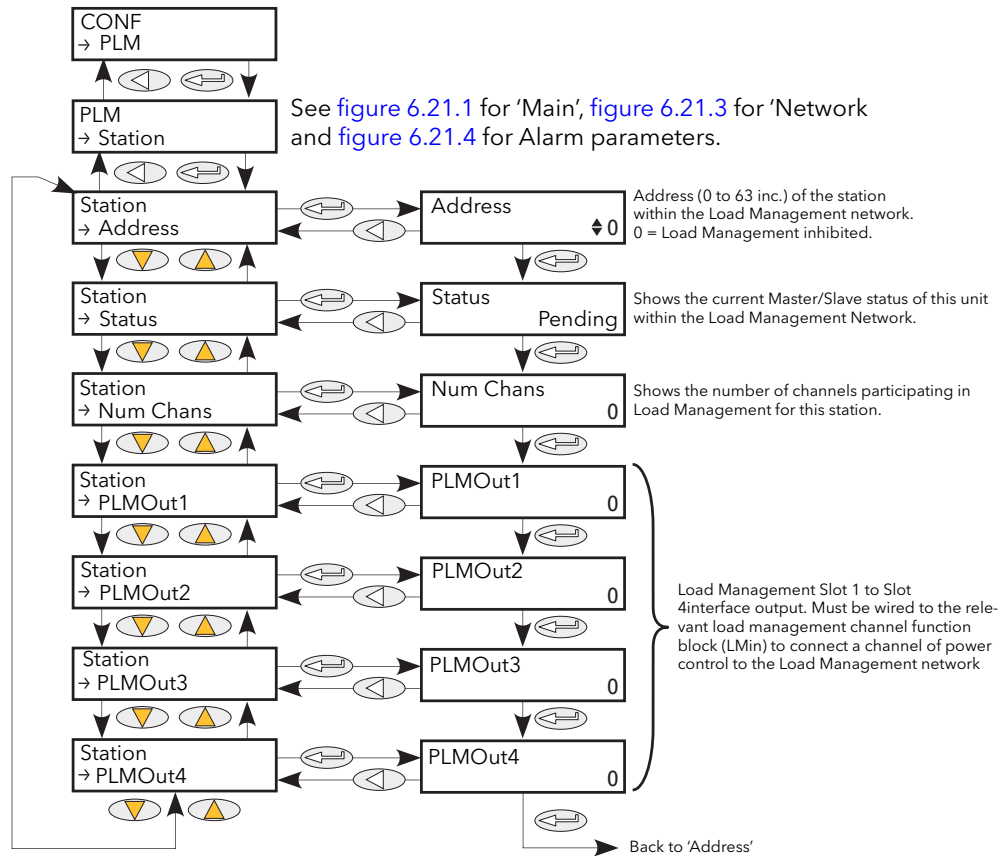

Figure 6.21.2 Load Management 'Station' menu.

Address	This is the address of the unit on the Load Management (PLM) network, between 0 and 63 inclusive. An address of 0 disables Load Management. The lowest address on the network normally becomes the master.
Status	Indicates the current master/slave status for this unit, as follows: Pending: The election of the master is not yet complete IsMaster: The unit is at the PLM network master IsSlave: This unit is a slave Duplicate address: Two or more units have the same address. Units with identical addresses are excluded from the load management process.
Num Chans	This shows the number of channels participating in load management for this unit. Automatically configured from the load management 'wiring' for this unit. Maximum number of channels = 64 Maximum number of channels per station = 4 Maximum number of stations = 64 Maximum number of groups = 8. Example 1: There can be a maximum of 16, four-channel units (i.e. 64 channels). Example 2: There can be a maximum of 63 three-phase units, (i.e. 63 channels).
PLMOut 1 to 4	These outputs must be wired to the load management channel function block PLMChan1 (to 4). PLMIn in order to connect a power control channel to the load management network.

6.21.3 Predictive Load Management 'Network' menu

This includes load management network parameters.

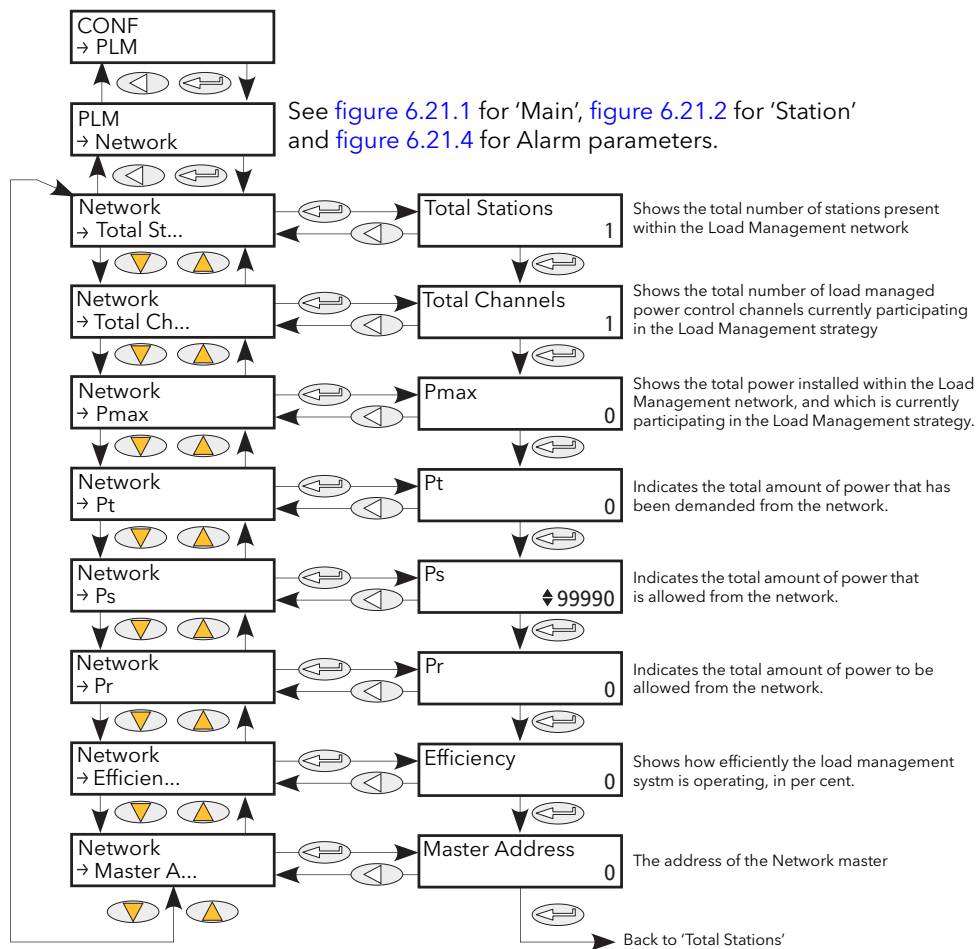

Figure 6.21.3 Load management 'Network' menu

Total Stations	Shows the number of units within the Load Management (PLM) network.
Total Channels	Shows the number of load management power channels currently participating in the Load Management strategy.
Pmax	This indicates the total amount of power installed and participating in the Load Management strategy, within the PLM network
Pt	The sum of the power demanded by all channels taking part in the Load Management strategy.
Ps	Configured by the user to restrict the power demanded from the network, according to the Load Shedding strategy (setting $P_s > P_{max}$ disables Load Shedding). Example: If the total installed power is 2.5MW but the user wishes to restrict the delivered power to be within a tariff band of 2MW, then P_s should be set to 2MW. Load shedding will shed power across the network to keep the total demand to less than 2MW.
Pr	This shows the total amount of power that has been delivered through the network. The value can be greater than P_s depending on the shedability factors of all channels.
Efficiency	Shows, in per cent, how efficient the load management strategy is. Calculated from: $\text{Efficiency \%} = \{P_{max} - (P_{tmax} - P_{tmin})\} / P_{max}$, where P_{tmax} and P_{tmin} are the peak maximum and minimum values for total power during the modulation period, respectively.
Master Address	Displays the address of the elected master on the Load Management network. For the master unit, this address is the same as the address set up in 'Station' described above. For a slave unit, the two addresses are different.

6.21.4 Predictive Load Management 'Alarm' menus

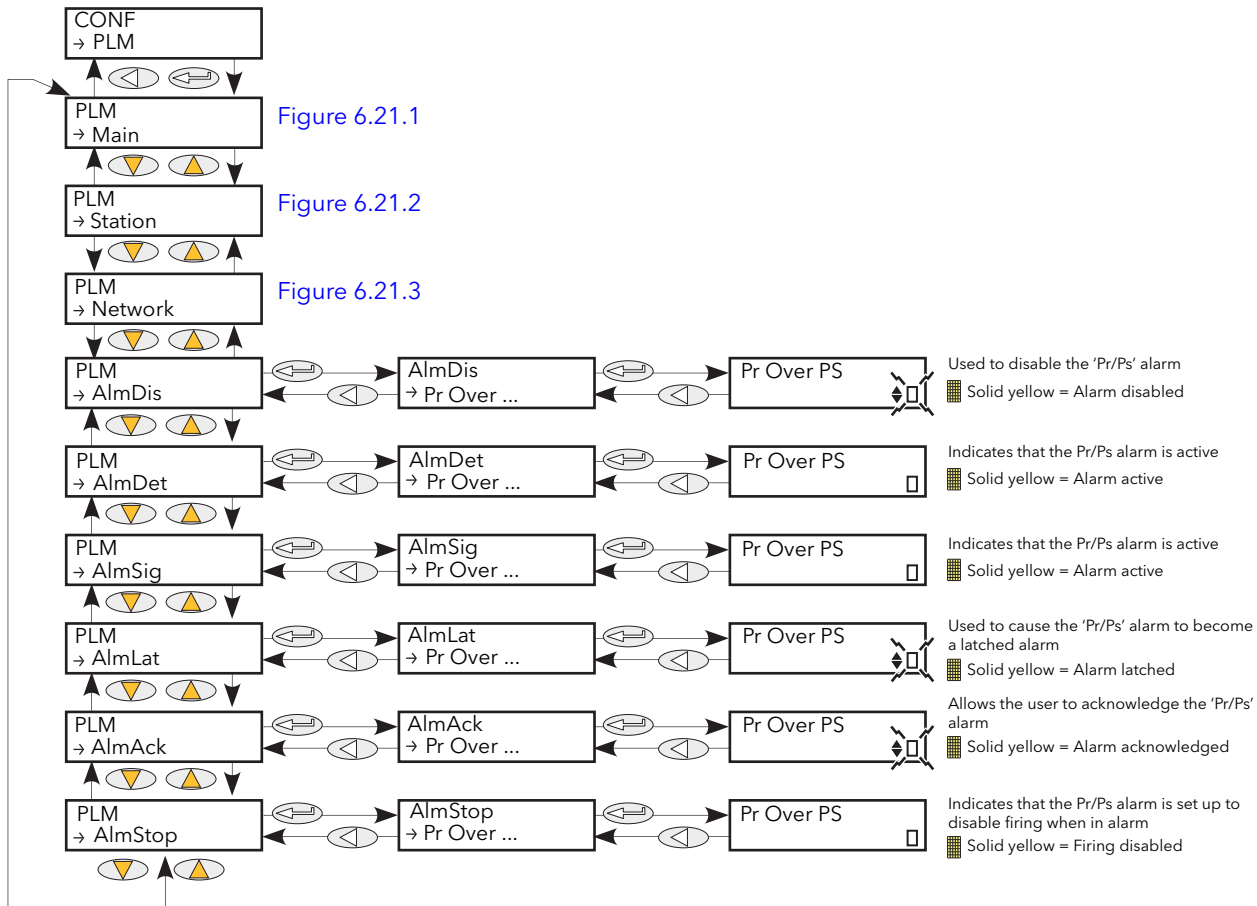

Figure 6.21.4 Load Management 'Alarm' menus

AlmDis	Allows the user to disable the Pr/Ps alarm.
AlmDet	Indicates to the user that Actual power is greater than the requested maximum. Caused by an incorrect calibration of one or more channels, or possibly as a result of load shedding.
AlmSig	Indicates whether or not Pr/Ps alarm has been detected. If action is to be taken as a result of this alarm's going active, then it is AlmSig that should be wired.
AlmLat	Allows the user to set Pr/Ps alarm to be a latching type.
AlmAck	Allows the user to acknowledge the Pr/Ps alarm.
AlmStop	Allows the Pr/Ps alarm to be configured to disable firing whilst active.

6.22 PLMCHAN (LOAD MANAGEMENT OPTION INTERFACE) MENU

This menu appears only if the Predictive Load Management option is fitted and enabled.

PLMChan provides an interface to the channel parameters needed for Load Management. See also [section 6.21](#) and [section 9](#).

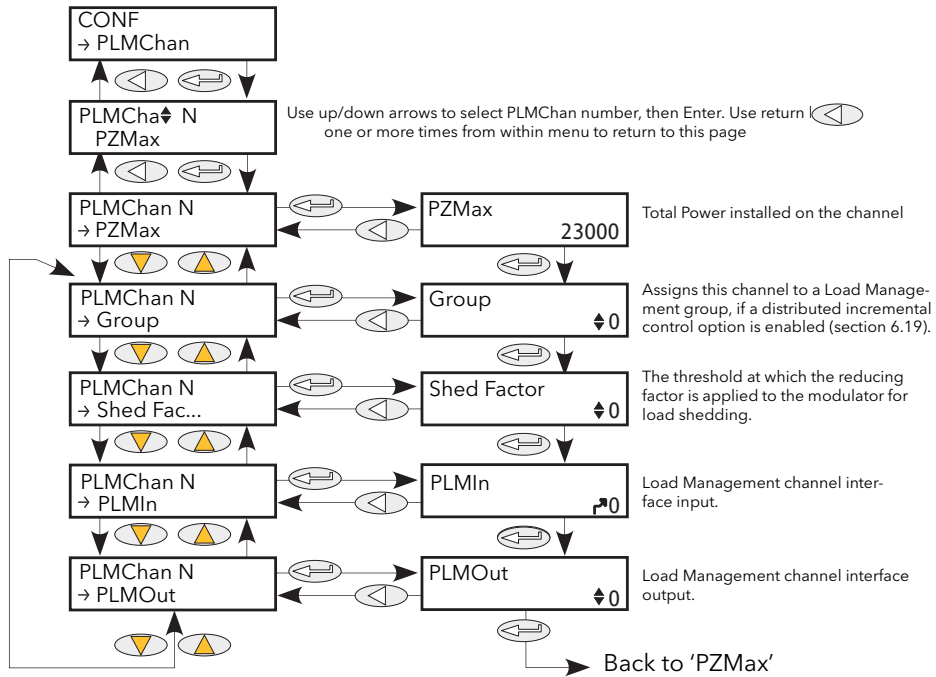

Figure 6.22 Predictive Load Management option interface menu

PZMax	Total power installed on the channel. Calculated using the rating of the unit.
Group	The group (max. = 8) in which the channel operates. This item appears only if one of the distributed incremental load management options has been selected (section 6.21).
ShedFactor	The threshold at which the reducing factor is applied to the modulator for load shedding. This item appears only if Load sharing is enabled (section 6.21)
LMIn	The Load Management channel interface input. Must be wired to one of the LMOut connections on the LoadMng function block in order to connect this channel to the network.
LMOut	The Load Management channel interface output. Typically wired to the LMIn parameter on the modulator block.

6.23 LOAD TAP CHANGER (LTC) OPTION

This option offers automatic load tap selection for primary or secondary windings, as configured. Instruments with this option must also be fitted with the remote current/voltage feedback option.

Figure 6.23 shows the overall menu structure. Figure 6.23.2 shows the Alarm menu, and figures 6.23.3a to 6.23.3f show some typical application wiring.

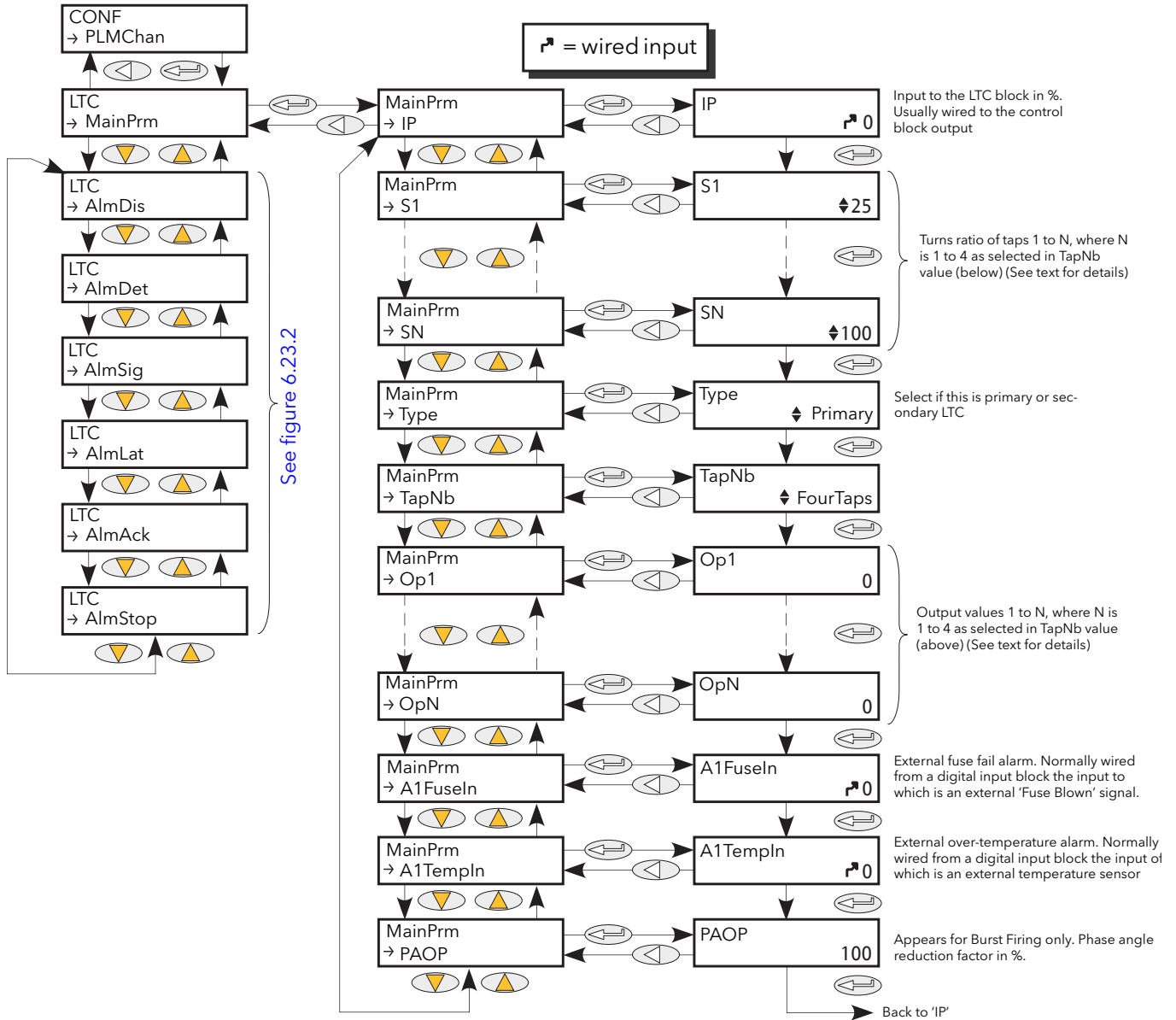

Figure 6.23 Load Tap Changer (LTC) menu overview

6.23.1 MainPrm parameters

IP	The % demand normally wired from a control block output
S1	Turns ratio of transformer tap 1 in percent. If Type = Primary, $s_1 = \frac{N_{T1T2}}{N_{Tot}} \times 100$ where N_{T1T2} is the number of turns between Tap1 and Tap 2, and N_{Tot} is the total number of turns. For the primary, T1 is the highest tap. If Type = Secondary, $s_1 = \frac{N_{T1}}{N_{Tot}} \times 100$ where N_{T1} is the number of turns in Tap 1 (lowest tap) and N_{Tot} is the total number of turns.
S2	Turns ratio of transformer tap 2 in percent. If Type = Primary, $s_1 = \frac{N_{T1T3}}{N_{Tot}} \times 100$ where N_{T1T3} is the number of turns between Tap1 and Tap 3, and N_{Tot} is the total number of turns. For the primary, T1 is the highest tap. If Type = Secondary, $s_1 = \frac{N_{T2}}{N_{Tot}} \times 100$ where N_{T2} is the number of turns in Tap 2 and N_{Tot} is the total number of turns. If the number of taps is 2, S2 = 100%
S3	Turns ratio of transformer tap 3 in percent. If Type = Primary, $s_1 = \frac{N_{T1T4}}{N_{Tot}} \times 100$ where N_{T1T4} is the number of turns between Tap1 and Tap 4, and N_{Tot} is the total number of turns. For the primary, T1 is the highest tap. If Type = Secondary, $s_1 = \frac{N_{T3}}{N_{Tot}} \times 100$ where N_{T3} is the number of turns in Tap 3 and N_{Tot} is the total number of turns. If the number of taps is 3, S3 = 100%
S4	Turns ratio of transformer tap 4 in percent. Value always 100%
Type	Select Load tap Changer type as 'Primary' or 'Secondary'.
TapNb	The number of transformer taps from two to four.
OpN	The value of outputs 1 to N of the block, where N is the number of transformer taps as selected in 'TapNb' above. This output is normally wired to the input of a Firing output block (for phase-angle firing) or to a Modulator block (Modulation mode firing).
A1FuselN	External Fuse Fail Alarm input. Wired to the output of a digital input, the input of which is wired to an external Fuse Blown transducer.
A1Templn	External over Temperature Alarm input. Wired to the output of a digital input, the input of which is wired to an external Over Temperature transducer.
PAOP	Phase Angle Reduction (This display appears only for Burst Firing applications.). If the value of this parameter is less than 100% a burst of phase angle is delivered. Used, for example, to perform threshold current limiting,

6.23.2 LTC Alarm

Displays the alarm configuration for the Load Tap Changer external Fuse Blown and over Temperature alarms. [Figure 6.23.2](#) shows the menu.

The parameters listed below apply to both alarms individually.

PARAMETERS

AlmDis	Allows the user to disable the alarm.
AlmDet	Indicates to the user whether or not the alarm is active.
AlmSig	Indicates to the user whether or not the alarm is active. If action is to be taken as a result of this alarm's going active, then it is AlmSig that should be wired.
AlmLat	Allows the user to set the alarm to be a latching type.
AlmAck	Allows the user to acknowledge the alarm.
AlmStop	Not configurable (see note).

Note: These two alarms are considered to be system alarms and automatically inhibit thyristor operation (firing) whilst active. 'AlmStop' cannot be set to 'No'.

6.23.2 LTC ALARM (Cont.)

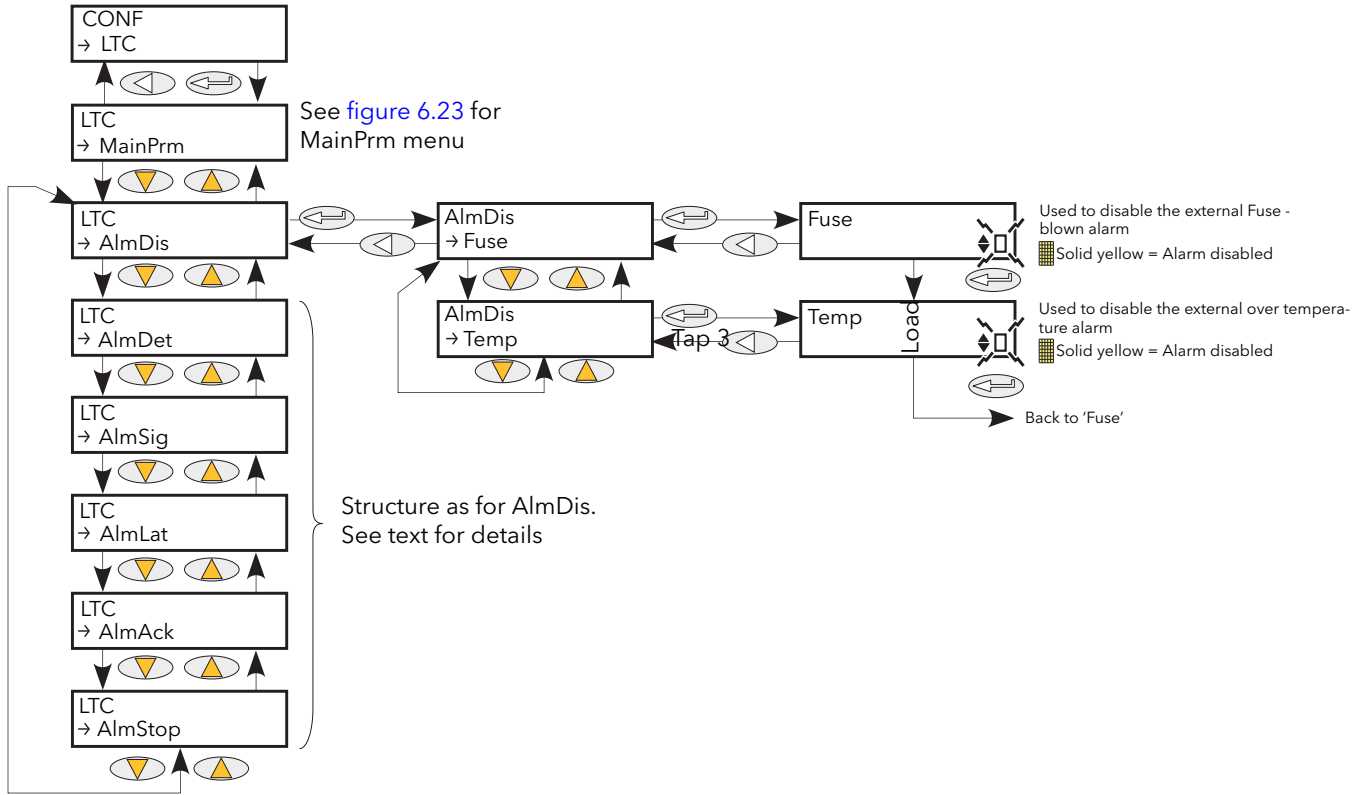

Figure 6.23.2 Load tap changer alarm menu

6.23.3 LTC Application wiring

The following illustrations, give typical wiring information for a number of different Load Tap Change applications. The diagrams are meant for guidance only and are not definitive.

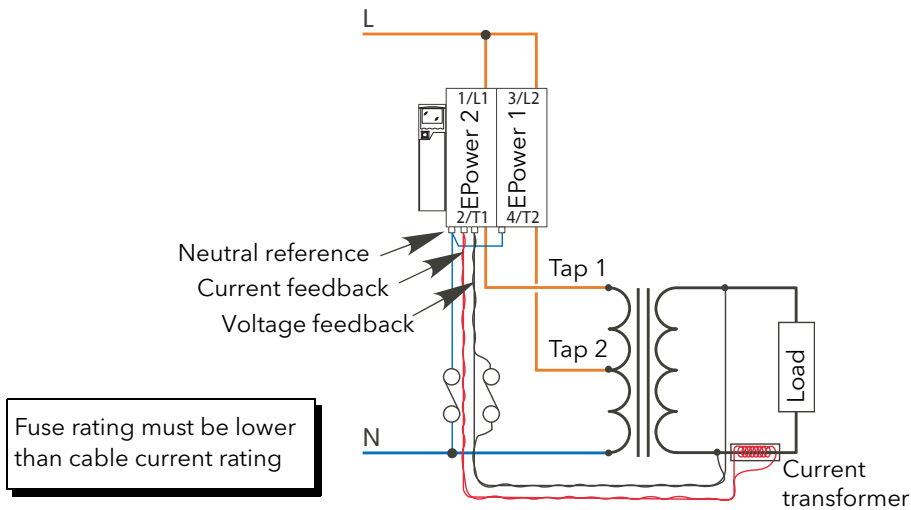

Figure 6.23.3a Two-tap primary

6.23.3 LTC APPLICATION WIRING (Cont.)

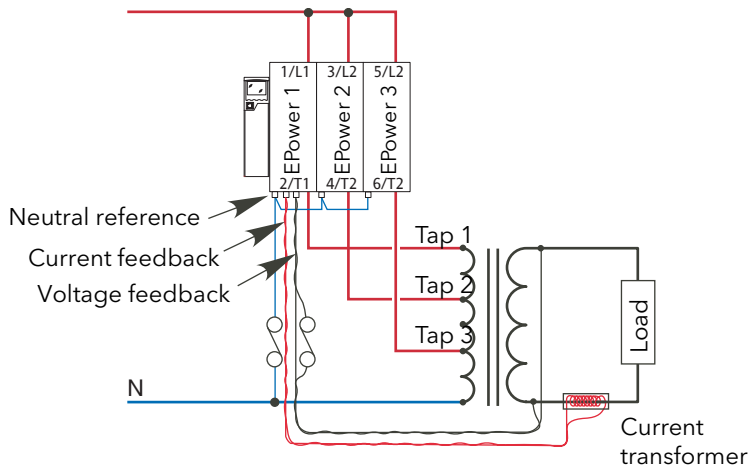

Figure 6.23.3b Three-tap primary

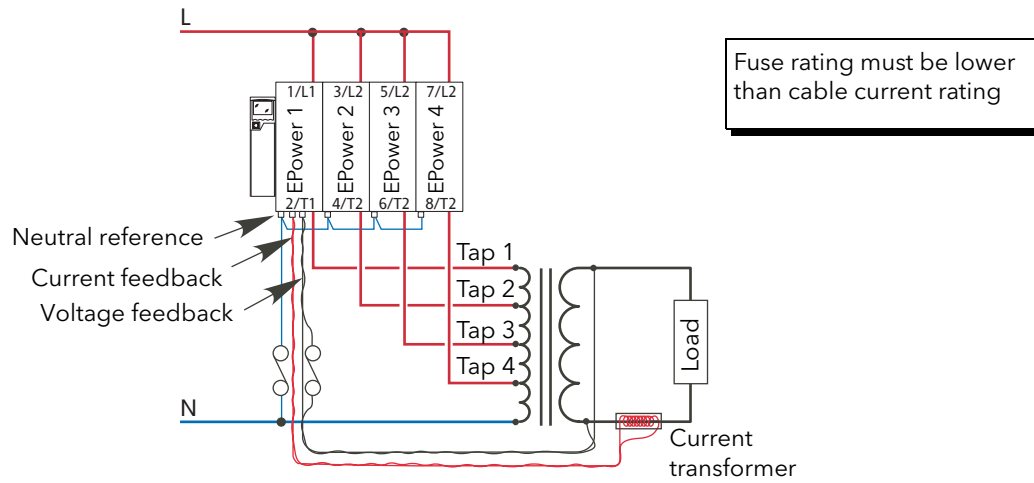

Figure 6.23.3c Four-tap primary

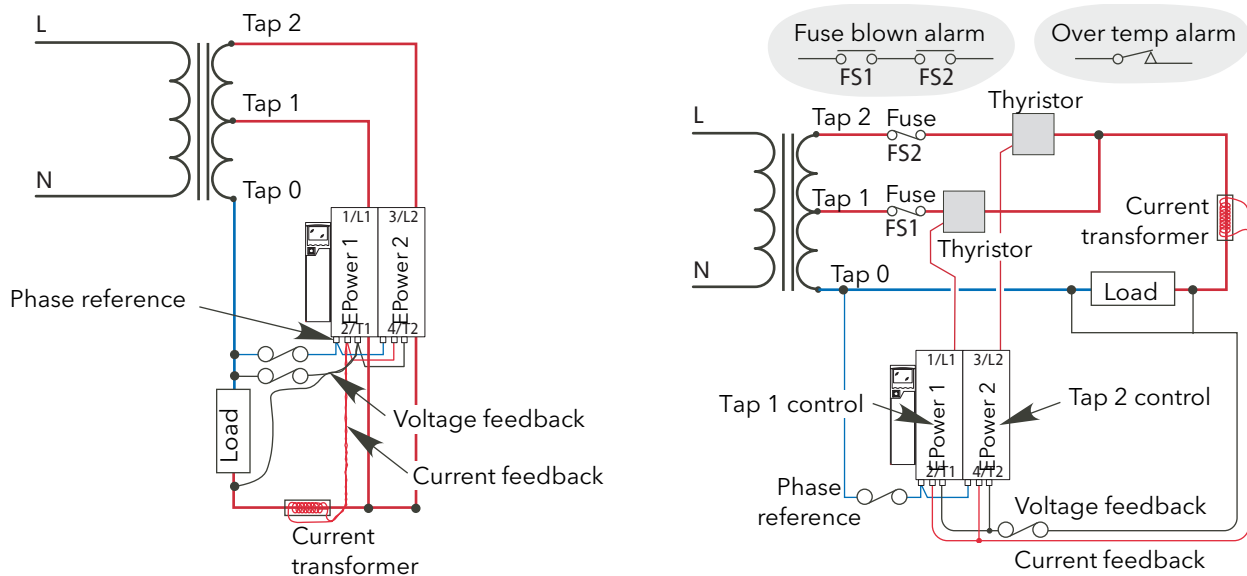
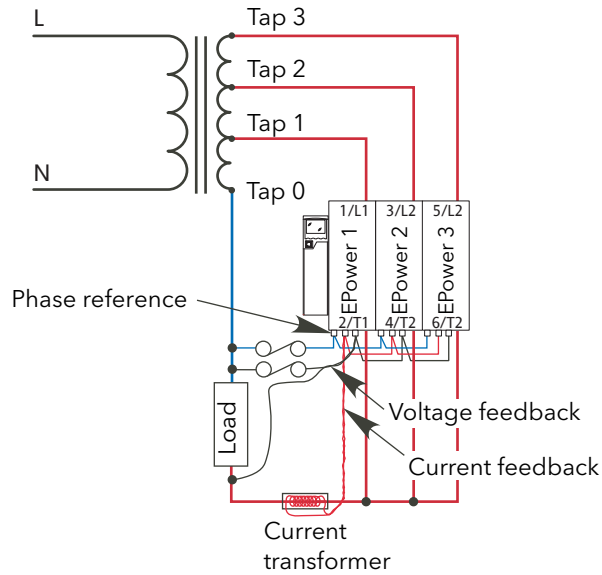

Figure 6.23.3d Two-tap secondary (alternative layouts)

6.23.3 LTC APPLICATION WIRING (Cont.)



Fuse rating must be lower than cable current rating

Figure 6.23.3e Three-tap secondary

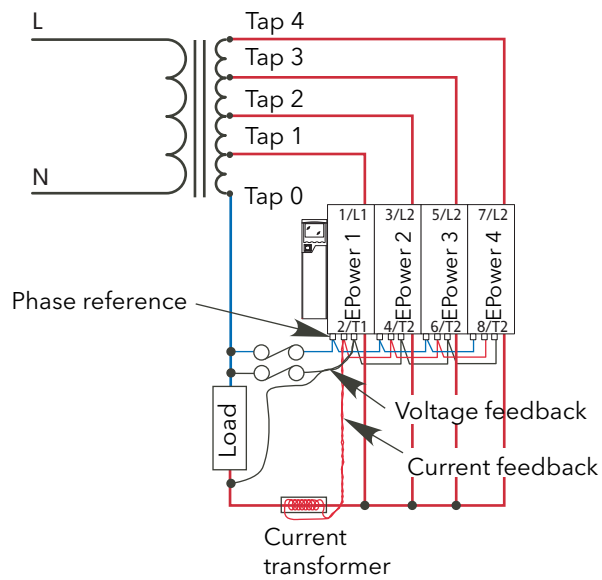

Figure 6.23.3f Four-tap secondary

6.24 RELAY MENU

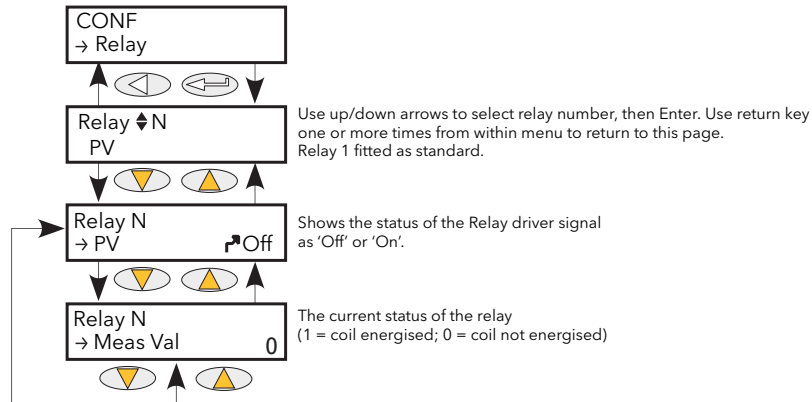

Figure 6.24 Relay menu

6.24.1 Relay parameters

PV This shows the status of the input to the relay as either 'On' (True) or 'Off' (False).
Meas Val Shows the current state of the relay coil. 1 = energised; 0 = de-energised, where 'energised' is 'off' and 'de-energised' is 'on'.

See [figures 2.2.1c](#) and [2.2.1d](#) for relay pinout details.

6.25 SETPROV MENU

This feature supplies 1 local and two remote setpoints.

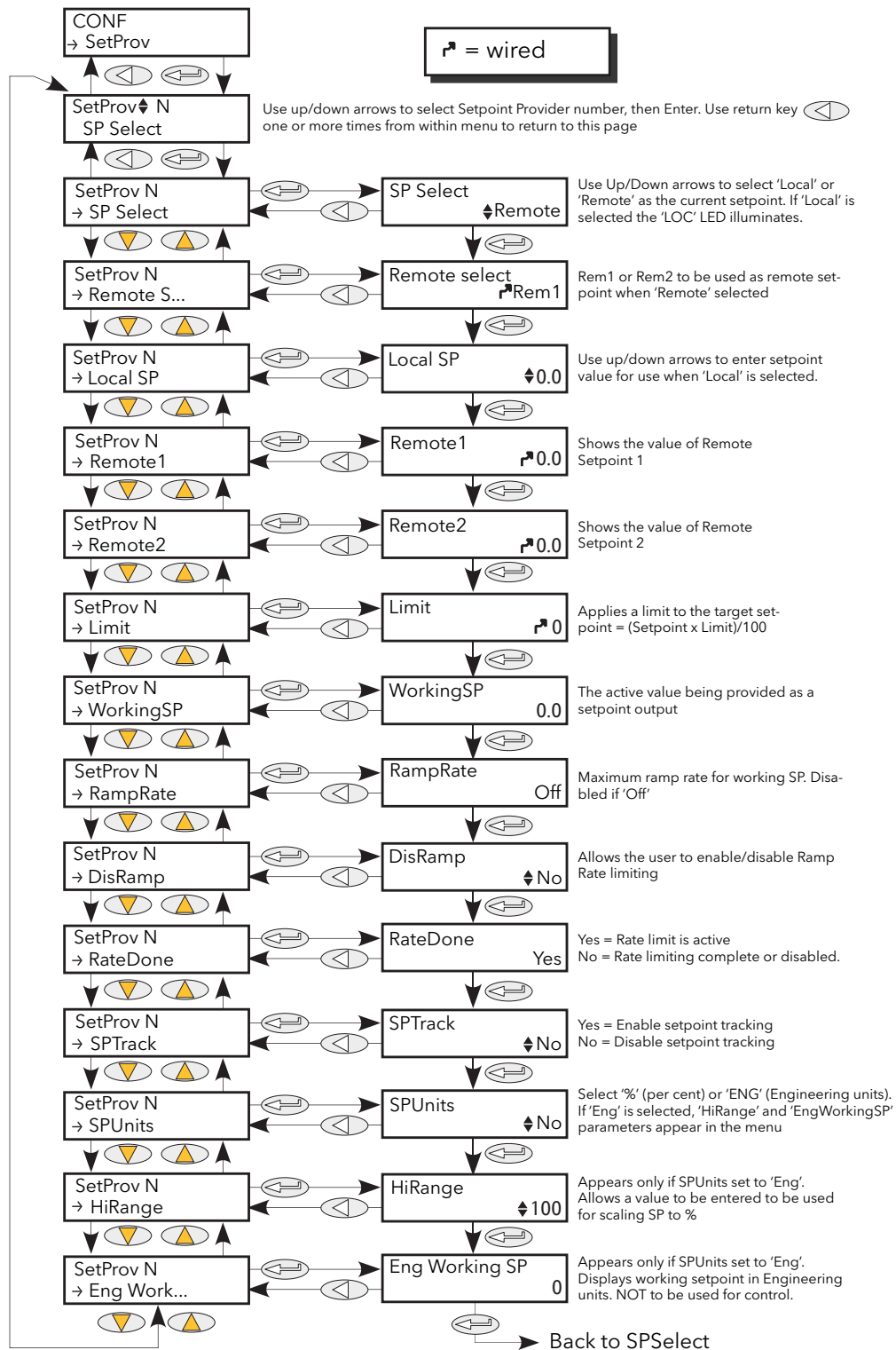

Figure 6.25 SetProv menu

6.25.1 Setpoint provider parameters

SPSelect	Allows the user to select between Remote or Local as the setpoint source. If 'Local' is selected, the 'LOC' LED illuminates.
Remote Select	Allows the user to select which of two Remote setpoints to use when SPSelect (above) is set to 'Remote'.
LocalSP	Allows entry of a setpoint value to be used when SPSelect (above) is set to 'Local'.
Remote1 (2)	The alternative Remote setpoints which may be chosen in 'Remote Select' (above).
Limit	Allows the target setpoint to be scaled such that 'scaled target SP' = (target SP x limit)/100. Thus, when limit = 100, the setpoint is unscaled.
WorkingSP	The active value being provided as a setpoint output. This might be the current target setpoint or the rate-limited target setpoint.
RampRate	This applies a rate limit to the working setpoint, until the target setpoint has been achieved. The 'RateDone' parameter (below) is set to 'No' for the duration of the rate limiting, then set to 'yes' when rate limiting is complete.
DisRamp	This is an external control used to enable/disable ramp rate limiting and to write the target setpoint directly to the working setpoint. The 'RateDone' parameter (below) is set to 'Yes' when DisRamp is 'Yes'.
RateDone	Set to 'No' if ramp rate limiting (above) is in operation. Otherwise set to 'Yes'.
SPTrack	If enabled ('Yes') the local setpoint tracks the remote setpoints, so that if the setpoint is subsequently set to 'Local', the local setpoint will be the same as the last known value of the remote setpoint, thus ensuring a bumpless transfer.
SPUnits	Allows the user to select % or 'Eng' (Engineering units) as Setpoint units. If 'Eng' is selected, 'HiRange' and 'Eng workingSP' appear at the user interface.
HiRange	Appears only if SP units set to 'Eng'. This value is the high range of the setpoint used to scale the setpoint into % of High Range.
EngWorkingSP	Appears only if SP units set to 'Eng'. This value is an indication of the working setpoint in Engineering units. The parameter must not be used for control because control loops accept setpoints only as % values.

6.26 TIMER MENU

6.26.1 Timer configuration

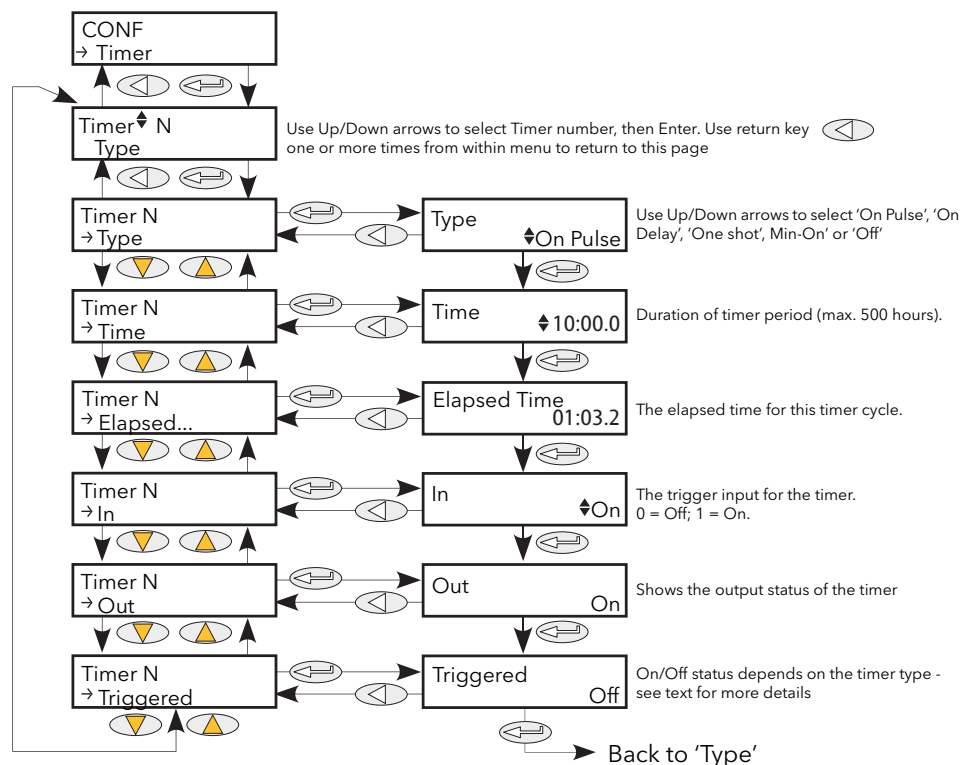

Figure 6.26.1 Timer Menu

Type

Allows the user to select the required timer type as follows:

- Off Timer is off
- On Pulse The timer output switches on when 'In' changes from Off to On, and it remains on until the time period ('Time' - see below) has elapsed. If the input is re-triggered before 'Time' has elapsed, the timer re-starts. 'Triggered' (below) follows the state of the output.
- On delay After the input changes from Off to On, the timer output remains off until the time period defined in 'Time' (below) has elapsed. Once this period has elapsed, if the input is still on, the output switches on and remains on until the input goes Off. Elapsed time is set to zero when the input goes off. 'Triggered' follows the state of the input.

6.26.1 TIMER CONFIGURATION (Cont.)

Type (Cont.)

One Shot If the input is On, then as soon as a value is entered into the 'Time' parameter (below) the output goes on, and remains on until the Time period has elapsed, or the input goes off. If the input is off, the output is set off and the time count-down is inhibited until input goes on again. 'Triggered' goes On as soon as the time value is edited, and remains on until the output goes Off.

The Time value may be edited whilst active. Once the time period has elapsed, the Time value must be re-edited in order to re-start the timer.

Min On The output remains 'On' as long as the Input is on, plus the 'Time' period (below). If the input returns to the on state before the time period has elapsed, the elapsed time is reset to zero, so that the full time period is added to the On period when the input switches off again. 'Triggered' is On whilst the elapsed time is greater than zero.

Time Allows the user to set a time period for use as described in 'Type' above. Initially, the display is in the form Minutes:seconds.10ths of seconds, but as the input value increases the format changes first to Hours:Mins:Secs, then to Hrs:Mins. (Holding the up arrow key continuously operated causes the speed at which the value increments to increase. Minimum entry is 0.1 seconds; maximum is 500 hours.

Elapsed Time Shows how much of the time period has passed so far.

In The timer trigger input. The function of this input varies according to timer type, as described above.

Out Shows the timer on/off status.

Trigger Function depends on timer type, as described above.

6.26.2 Timer examples

Figure 6.26.2 shows some timing examples for the different types of timer available.

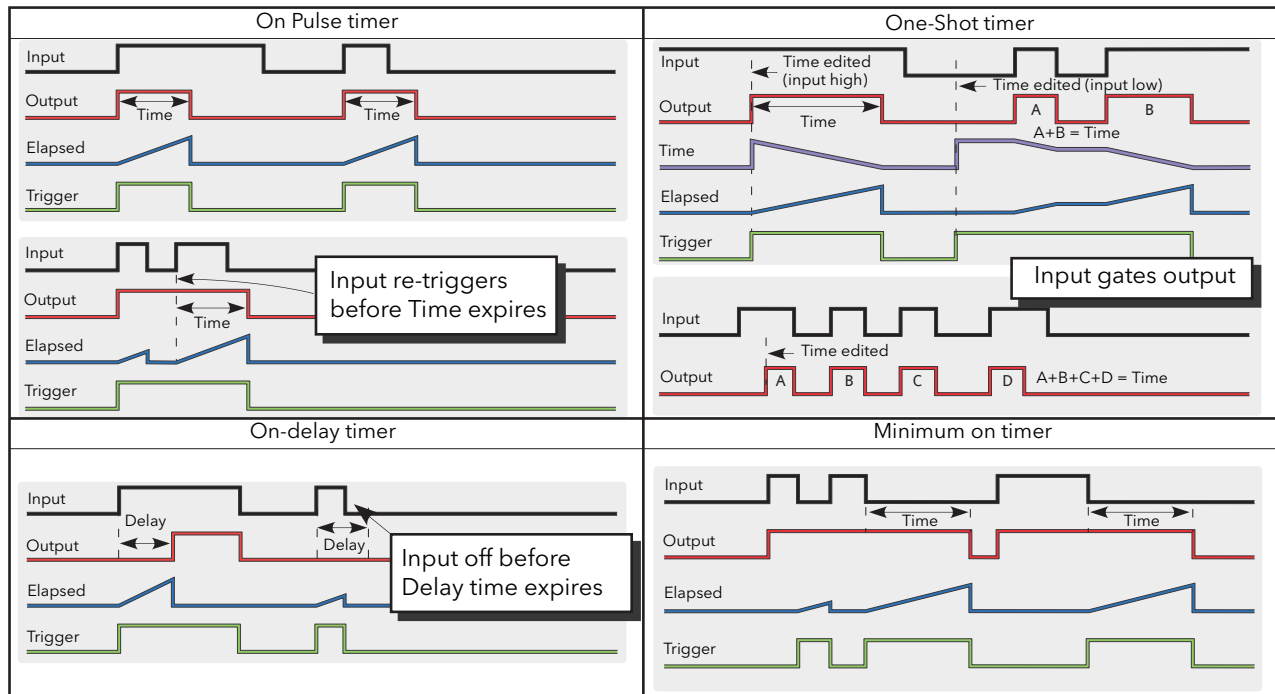

Figure 6.26.2 Timer examples

6.27 TOTALISER MENU

The totaliser is an instrument function used to calculate a total quantity by integrating a flow rate input over time. The maximum value of the totaliser is +/- 99999. The outputs from a totaliser are its integrated value, and an alarm state.

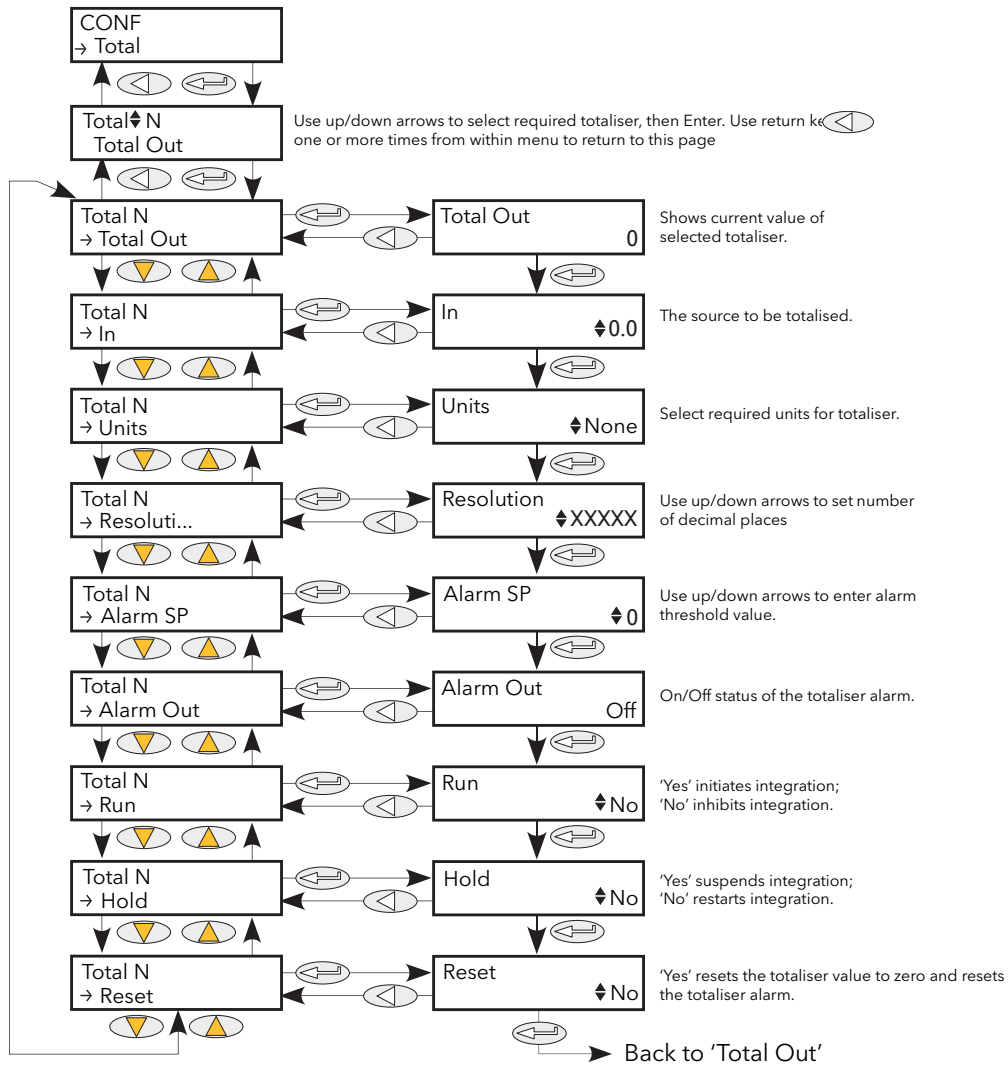

Figure 6.27 Totaliser menu

Total Out	The integrated total between -10^{10} and $+10^{10}$ (i.e. $\pm 10,000,000,000$)
In	The parameter to be totalised.
Units	Units of the totalised measurement.
Resolution	Set the number of decimal places for the totaliser value.
AlarmSP	Totaliser alarm setpoint. This threshold is applied to the totalised measurement. When totalising positive values, a positive AlarmSP value must be entered; the totaliser alarm being triggered when the totaliser value reaches or exceeds AlarmSP. When totalising negative values, a negative value must be entered; the totaliser alarm being triggered when the totaliser value reaches or goes more negative than AlarmSP. If set to zero, the alarm is disabled.
AlarmOut	The on/off status of the totaliser alarm.
Run	Yes initiates integration; No inhibits integration.
Hold	Yes suspends integration; No restarts integration.
Reset	Yes resets the totaliser value to zero and resets the totaliser alarm.

6.28 USER VALUE MENU

This provides storage for a user-defined constant. Typical uses are as a source for a maths function, or as storage for values written over the communications link.

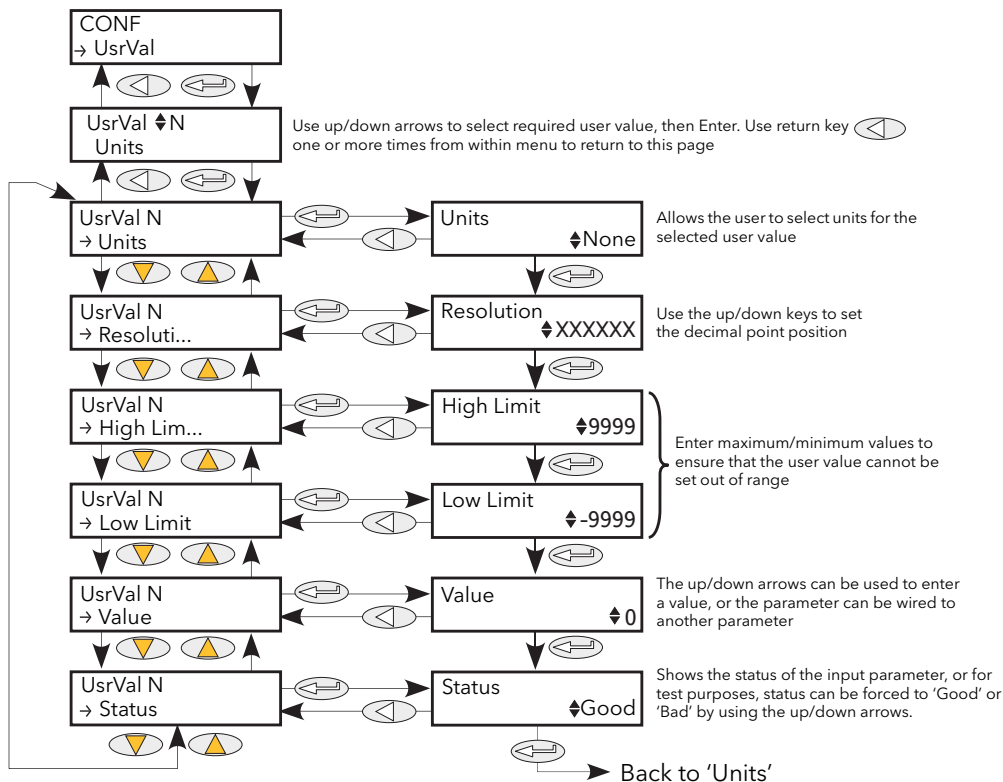

Figure 6.28 User Value menu

Units	Allows the selection of User value units.
Resolution	Set the number of decimal places for the User Value value.
High/Low Limit	Allows the user to set limits to prevent the user value from being set out-of-bounds.
Value	Allows the user to enter a value, or the parameter is wired to a suitable parameter.
Status	If this parameter is wired, it can be used to force a Good or Bad status onto the User Value for test purposes (e.g. fallback strategy). If not wired, it reflects the status of the Value input if this input is wired.

7 USING ITOOLS

iTools software running on a pc allows quick and easy access to the configuration of the unit. The parameters used are the same as those described in [section 6](#) above, with the addition of various diagnostic parameters. iTools also gives the user the ability to create software wiring between function blocks, something that is not possible from the operator interface. Such wiring is carried out using the Graphical wiring Editor feature.

In addition to the guidance given here, there are two on-line Help systems available within iTools: Parameter help and iTools help. Parameter help is accessed by clicking on 'Help' in the toolbar (opens the complete parameter help system), by right-clicking on a parameter and selecting 'Parameter Help' from the resulting context menu, or by clicking on the Help menu and selecting 'Device Help'. iTools help is accessed by clicking on the Help menu, and selecting 'Contents'. iTools help is also available in manual format under part number HA028838, either as a physical manual or as a pdf file.

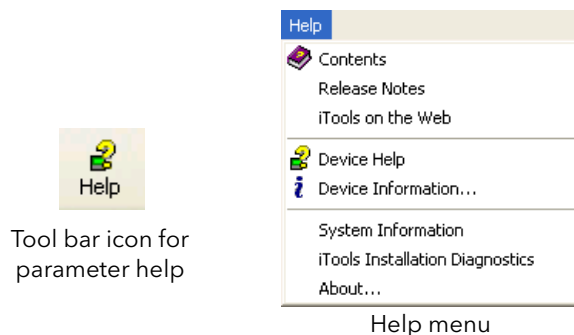

Figure 7 Help access

7.1 iTools CONNECTION

The following descriptions assume that iTools software has been correctly installed on the pc.

7.1.1 Serial communications

Once the serial link has been correctly wired, start iTools and click on the Scan toolbar icon. The iTools scanning feature initiates a search for compatible instruments, and a 'thumbnail' of each one found appears in the 'Panel Views' pane, normally located at the bottom of the screen. The scan can be stopped at any time by clicking on the Scan toolbar icon a second time.



Note: [Section 7.2](#) contains more details of the scan process.

7.1.2 Ethernet (Modbus TCP) communications

Note: the following description is based on windows XP. Windows 'Vista' is similar.

It is first necessary to determine the IP address of the unit, as described under 'Comms menu' in section 6.6. This can be done from either the Engineer menu or the Config menu.

Once the Ethernet link has been correctly installed, carry out the following actions at the pc:

1. Click on 'Start'
2. Click on 'Control Panel'. (If Control Panel opens in 'Category View' select 'Classic View' instead.)
3. Double-click on 'iTools'.
4. Click on the TCP/IP tab in the Registry settings configuration.
5. Click on Add... The 'New TCP/IP Port' dialogue box opens.
6. Type-in a name for the port, then click Add...
7. Type the IP address of the unit in the 'Edit Host' box which appears. Click OK.
8. Check the details in the 'New TCP/IP Port' box, then click on 'OK'.
9. Click on 'OK' in the 'Registry settings' box to confirm the new port.

(Continued)

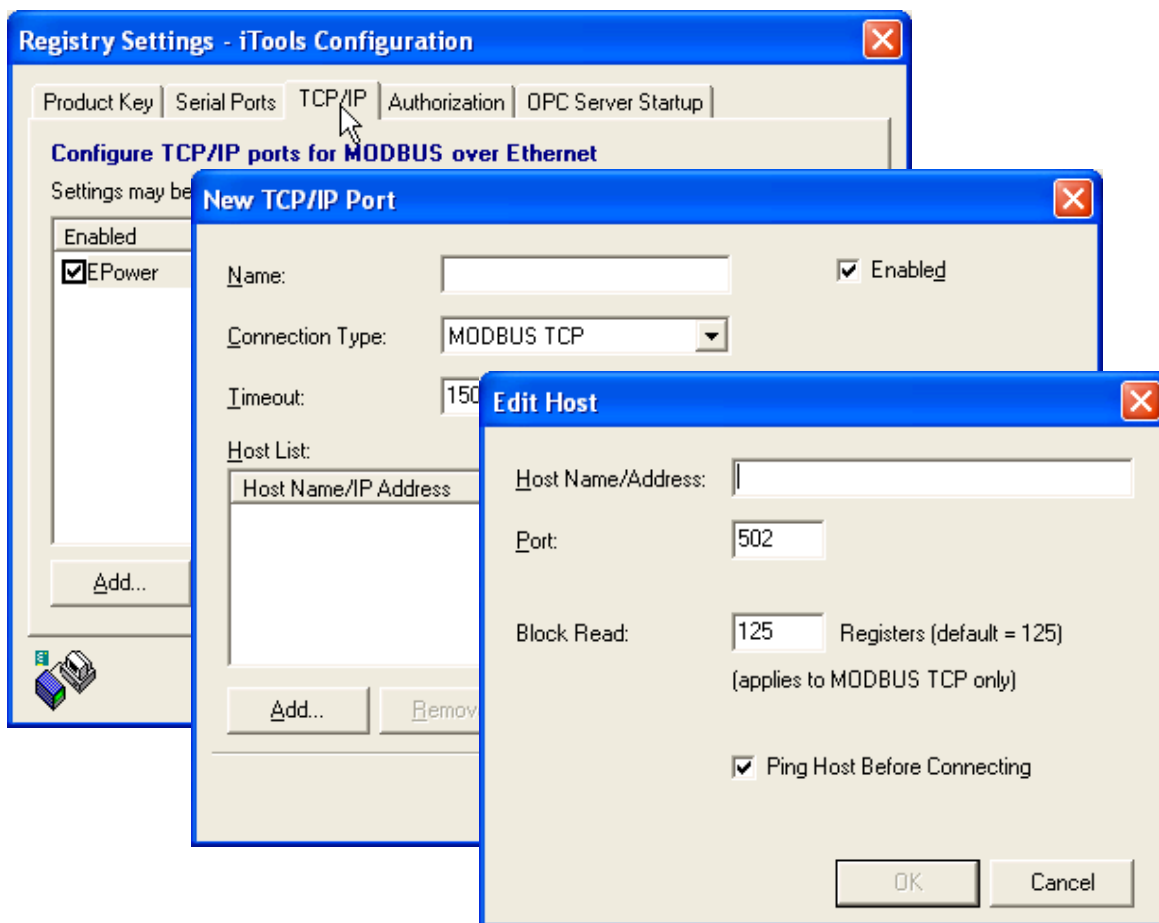

Figure 7.1.2a Adding a new Ethernet port

7.1.2 ETHERNET (TCP/IP) COMMUNICATIONS (Cont.)

To check that the pc can now communicate with the instrument, Click 'Start'. 'All Programs', 'Accessories', 'Command Prompt'

when the Command Prompt box appears, type in : Ping<Space>IP1.IP2.IP3.IP4<Enter> (where IP1 to IP4 are the IP address of the instrument).

If the Ethernet link to the instrument is operating correctly, the 'successful' reply arrives. Otherwise, the 'failed' reply arrives, in which case, the Ethernet link, IP address, and pc port details should be verified.

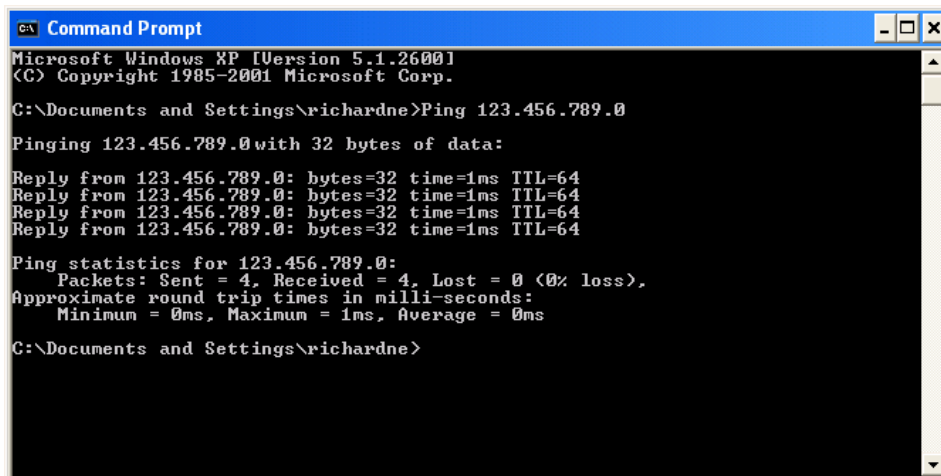

```
CA\ Command Prompt
Microsoft Windows XP [Version 5.1.2600]
(C) Copyright 1985-2001 Microsoft Corp.

C:\Documents and Settings\richardne>Ping 123.456.789.0

Pinging 123.456.789.0 with 32 bytes of data:

Reply from 123.456.789.0: bytes=32 time=1ms TTL=64
Reply from 123.456.789.0: bytes=32 time=1ms TTL=64
Reply from 123.456.789.0: bytes=32 time=1ms TTL=64
Reply from 123.456.789.0: bytes=32 time=1ms TTL=64

Ping statistics for 123.456.789.0:
    Packets: Sent = 4, Received = 4, Lost = 0 (0% loss),
    Approximate round trip times in milli-seconds:
        Minimum = 0ms, Maximum = 1ms, Average = 0ms

C:\Documents and Settings\richardne>
```

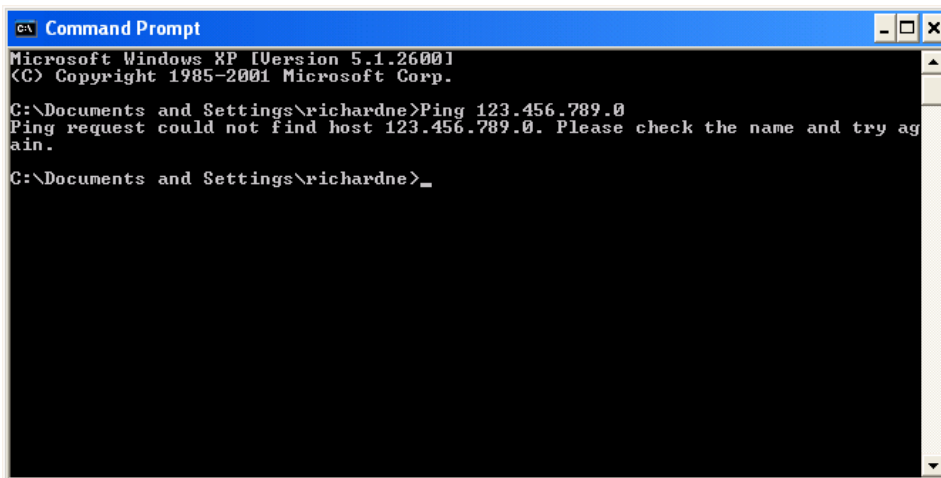

```
CA\ Command Prompt
Microsoft Windows XP [Version 5.1.2600]
(C) Copyright 1985-2001 Microsoft Corp.

C:\Documents and Settings\richardne>Ping 123.456.789.0
Ping request could not find host 123.456.789.0. Please check the name and try again.

C:\Documents and Settings\richardne>_
```

Figure 7.1.2a Command prompt 'Ping' screens (typical)

Once the Ethernet link to the instrument has been verified, iTools can be started (or shut down and restarted), and the Scan toolbar icon used, to 'find' the instrument. The scan can be stopped at any time by clicking on the Scan icon a second time.



See [section 7.2](#) for more details of the scan procedure.

7.2 SCANNING FOR INSTRUMENTS

Clicking on the 'Scan' toolbar icon causes a dialogue box (shown below) to appear. This allows the user to define a search range of addresses.

Notes:

1. The relevant instrument address is that entered in the **Comms User menu 'Address' item**, and it can take any value between 1 and 254 inclusive, as long as it is unique to the comms link.
2. The default selection (Scan all device addresses...) will detect any instrument on the serial link, which has a valid address.

As the search progresses, any instruments detected by the scan appear as thumbnails (faceplates) in the 'Panel Views' area, normally located at the bottom of the iTools screen. (options/Panel Views position allows this area to be moved to the top of the window, or the Close icon  can be used to close it. Once closed it can be re-opened by clicking on 'Panel Views' in the 'View' menu.)

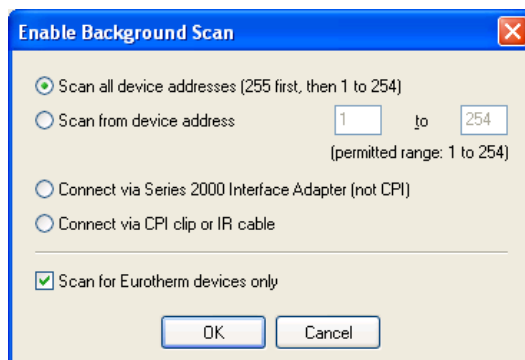

Figure 7.2a Scan range enable

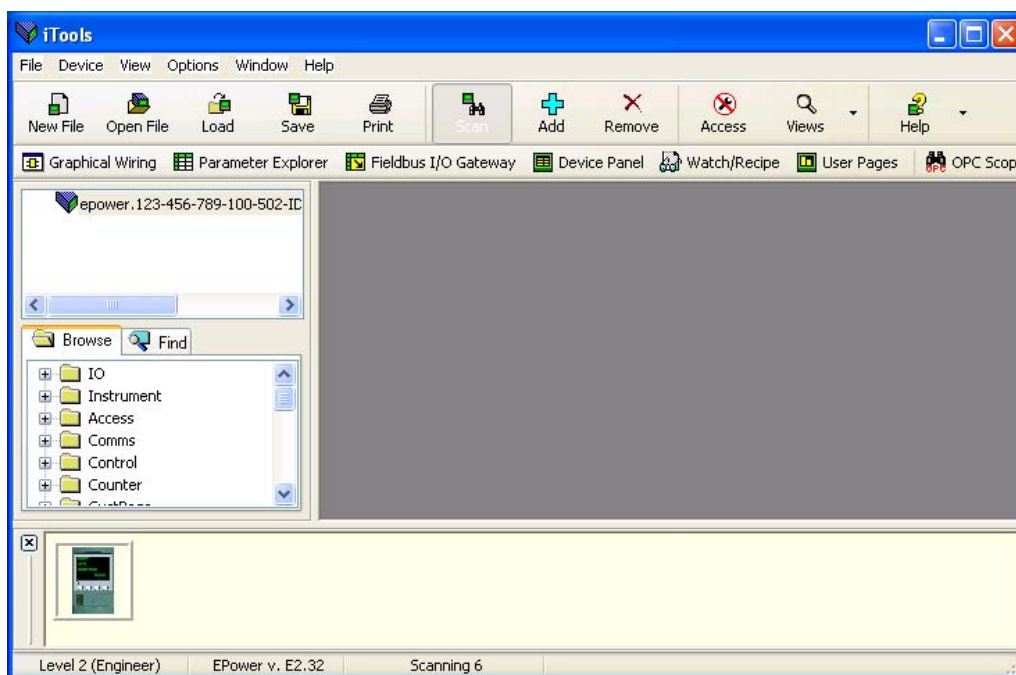

Figure 7.2b iTools initial window with one instrument detected

7.3 GRAPHICAL WIRING EDITOR

Clicking on the Graphical wiring Editor toolbar icon causes the Graphical wiring window for the current instrument configuration to open. Initially, this reflects the function block wiring as set in the [Quick Start menu](#).

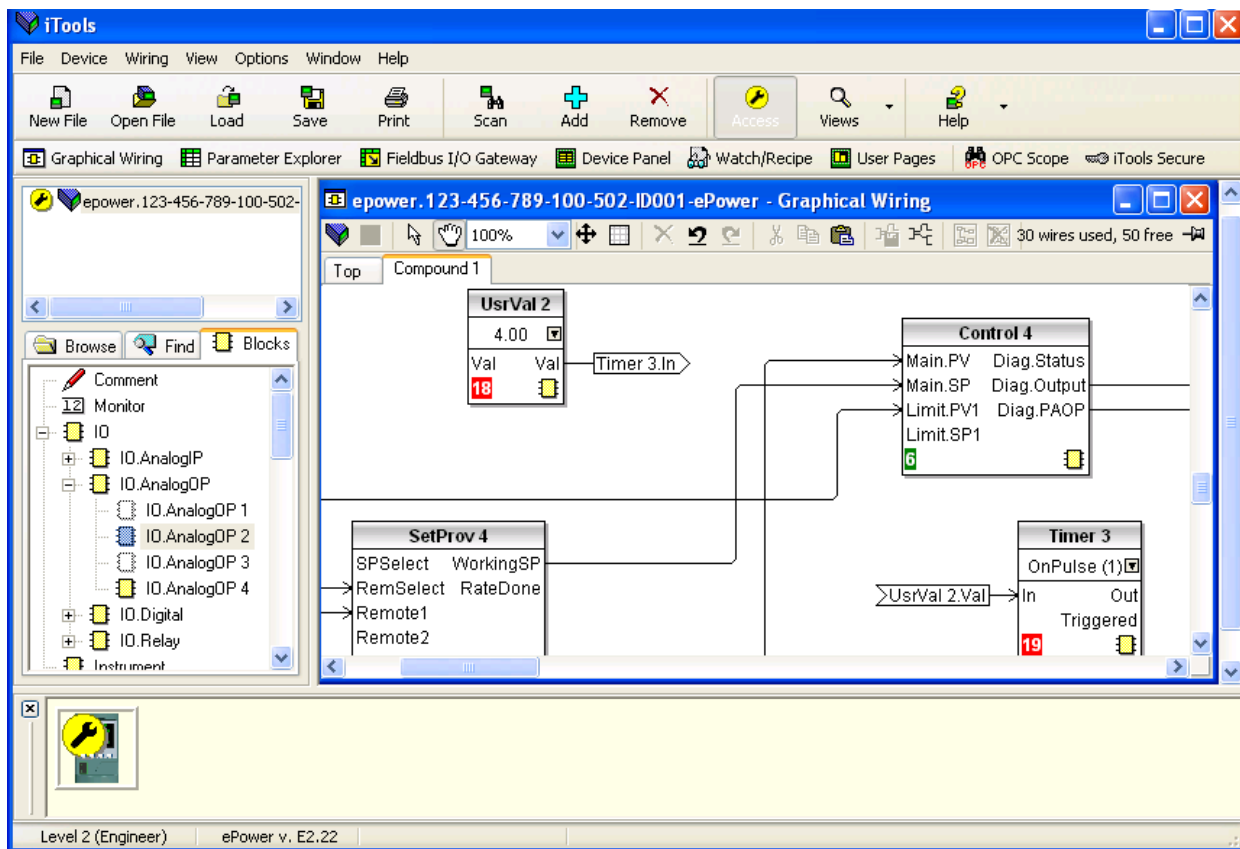
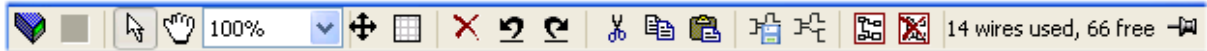





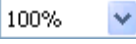



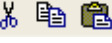

Figure 7.3 Graphical wiring Editor

The graphical wiring editor allows:

1. Function blocks, notes, comments etc. to be 'drag and dropped' into the wiring diagram from the tree list (left pane).
2. Parameters to be wired to one another by clicking on the output, then clicking on the required input.
3. Viewing and/or editing of parameter values by right-clicking on a function block and selecting 'Function Block View'.
4. The user to select parameter lists and to switch between parameter and wiring editors.
5. Completed wiring to be downloaded to the instrument (function blocks and wiring items with dashed outlines are new, or have been edited since the last download).

7.3.1 Toolbar



-  Download wiring to Instrument.
-  Mouse Select. Select normal mouse operation. Mutually exclusive with 'Pan', below.
-  Mouse Pan. When active, this causes the mouse cursor to become a hand-shaped icon. Allows the graphical wiring diagram to be click-dragged within the GWE window aperture.
-  Zoom. Allows the magnification of the wiring diagram to be edited.
-  Pan tool. Whilst left-clicked, the cursor appears as a rectangle, representing the position of GWE window aperture over the whole wiring diagram. Click dragging allows this aperture to be moved freely about the diagram. Rectangle size depends on Zoom (magnification) factor.
-  Show/Hide grid. This icon toggles a background alignment grid on and off.
-  Undo, Redo. Allows the user to undo the last action, or once an undo action has taken place, to undo the undo. Short cuts are <Ctrl>+<Z> for undo; <Ctrl>+<R> for re-do.
-  Cut, Copy, Paste. Normal Cut (copy and delete), Copy (copy without delete) and Paste (insert into) functions. Short cuts are <Ctrl>+<X> for cut; <Ctrl>+<C> for copy and <Ctrl>+<V> for Paste.
-  Copy diagram fragment; Paste diagram fragment. Allows a part of the wiring diagram to be selected, named and saved to file. The fragment may then be pasted into any wiring diagram, including the source diagram.
-  Create compound; Flatten compound. These two icons allow compounds to be created and 'uncreated' respectively.

7.3.2 Wiring editor operating details

COMPONENT SELECTION

Single wires are shown with boxes at 'corners' when selected. When more than one wire is selected, as part of a group, the wire colour changes to magenta. All other items have a dashed line drawn round them when selected.

Clicking on a single item selects it. An Item can be added to the selection by holding down the control key (ctrl) whilst clicking on the item. (A selected item can be deselected in the same way.) If a block is selected, then all its associated wires are also selected.

Alternatively, the mouse can be click-dragged on the background to create a 'rubber band' round the relevant area; anything within this area being selected when the mouse is released.

<Ctrl>+<A> selects all items on the active diagram.

BLOCK EXECUTION ORDER

The order in which the blocks are executed by the instrument depends on the way in which they are wired. The order is automatically worked out, for each 'Task' (or network block) so that the blocks use the most recent data. Each block displays its place in its sequence in a coloured block in the bottom left-hand corner (figure 7.3.2a). The colour of the block represents the Task within which the block is running: red = task one, green = task two, black = task 3 and blue = task 4.

7.3.2 WIRING EDITOR OPERATING DETAILS (Cont.)

FUNCTION BLOCKS

A Function Block is an algorithm which may be wired to and from other function blocks to make a control strategy. Each function block has inputs and outputs. Any parameter may be wired from, but only parameters that are alterable in Operator Mode may be wired to. A function block includes any parameters that are needed to configure or operate the algorithm. The inputs and outputs which are considered to be of most use are always shown. In most cases all of these need to be wired before the block can perform a useful task.

If a function block is not faded in the tree (left hand pane) it can be dragged onto the diagram. The block can be dragged around the diagram using the mouse.

A Maths block is shown below as an example. When block type information is alterable (as in this case) click on the box with the down arrow in it to display a dialogue box allowing the value to be edited.

If it is required to wire from a parameter, which is not shown as a recommended output, click on the 'Click to Select Output' icon in the bottom right hand corner to display a full list of parameters in the block (figure 7.3.2c, below). Click on one of these to start a wire.

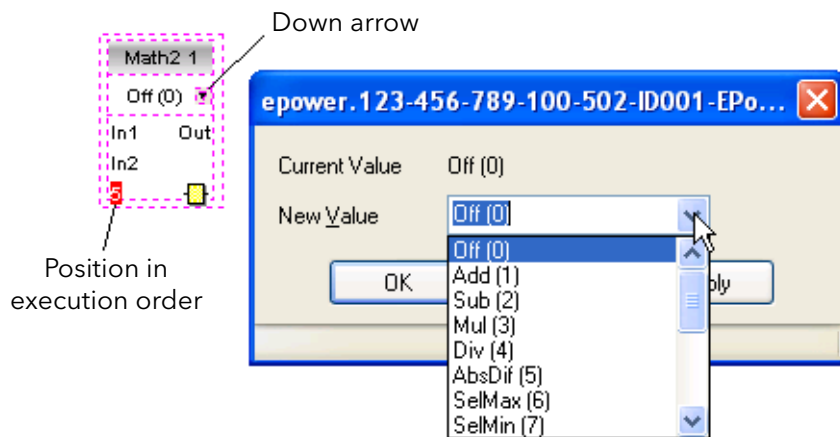

Figure 7.3.2a Function block example

Function Block context menu

Right click in the function block to display the context menu.

Function block View Displays a list of parameters associated with the function block. 'Hidden' parameters can be displayed by de-selecting 'Hide Parameters and Lists when not Relevant' in the Options menu 'Parameter availability Settings...'

Re-Route wires Redraws all wiring associated with the function block.

Re-Route Input wires Redraws all Input wiring associated with the function block.

Re-Route Output wires Redraws all Output wiring associated with the function block.

Show Wires Using Tags Wires are not drawn, but their Start and End destinations are indicated by tags instead. Reduces wire 'clutter' in diagrams, where source and destination are widely separated.

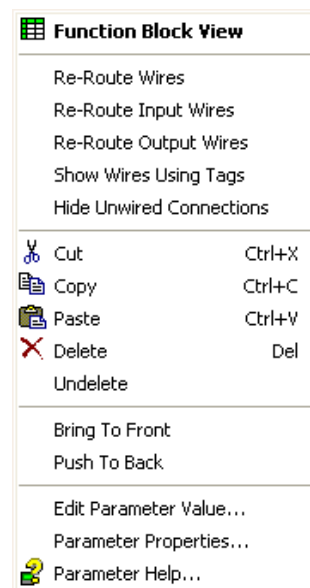
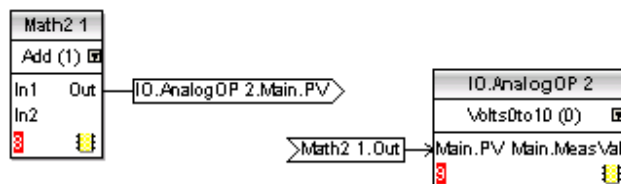

Figure 7.3.2b Function block context menu



7.3.2 WIRING EDITOR OPERATING DETAILS (Cont.)

FUNCTION BLOCK CONTEXT MENU (Cont.)

Hide Unwired Connections

Displays only those parameters which are wired.

Cut

Allows one or more selected items to be moved to the Clipboard ready for pasting into another diagram or compound, or for use in a Watch window, or OPC scope. The original items are greyed out, and function blocks and wires are shown dashed until next download, after which they are removed from the diagram. Short cut = <ctrl>+<X>. Cut operations carried out since the last download can be 'undone' by using the 'Undo' toolbar icon, by selecting 'Undelete' or by using the short cut <ctrl>+<Z>.

Copy

Allows one or more selected items to be copied to the Clipboard ready for pasting into another diagram or compound, or for use in a Watch window, or OPC scope. The original items remain in the current wiring diagram. Short cut = <ctrl>+<C>. If items are pasted to the same diagram from which they were copied, the items will be replicated with different block instances. Should this result in more instances of a block than are available, an error display appears showing details of which items couldn't be copied.

Paste

Copies items from the Clipboard to the current wiring diagram. <Ctrl>+<V>. If items are pasted to the same diagram from which they were copied, the items will be replicated with different block instances. Should this result in more instances of a block than are available, a Paste error display appears showing details of which items couldn't be copied.

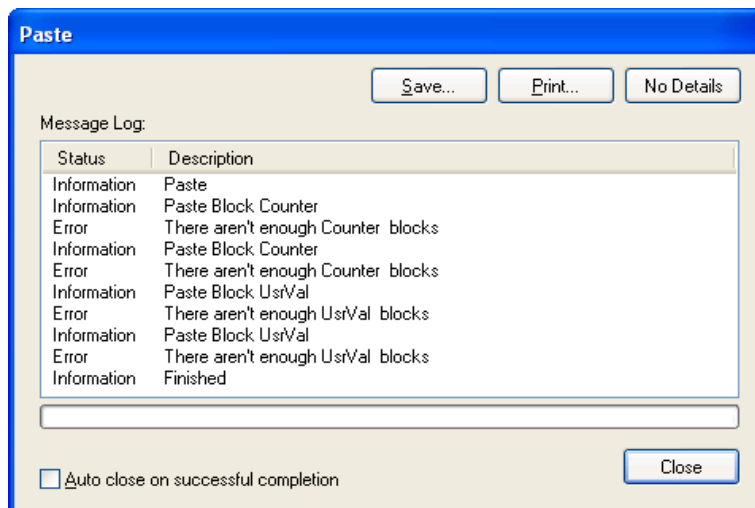

Delete

Marks all selected items for deletion. Such items are shown dashed until next download, after which they are removed from the diagram. Short cut = .

Undelete

Reverses 'Delete' and 'Cut' operations carried out on selected item(s) since the last download.

Bring To Front

Brings selected items to the front of the diagram.

Push To back

Sends the selected items to the back of the diagram.

Edit Parameter Value...

This menu item is active if the cursor is hovering over an editable parameter. Selecting this menu item causes a pop-up window to appear, which allows the user to edit the parameter value.

Parameter Properties...

This menu item is active if the cursor is hovering over an editable parameter. Selecting this menu item causes a pop-up window to appear, which allows the user to view the parameter properties, and also, to view the parameter Help (by clicking on the 'Help' tab).

Parameter Help...

Produces Parameter Properties and Help information for the selected function block or parameter, depending on the hover position of the cursor, when the right-click occurs.

7.3.2 WIRING EDITOR OPERATING DETAILS (Cont.)

WIRES

To make a wire

1. Drag two (or more) blocks onto the diagram from the function block tree.
2. Start a wire by either clicking on a recommended output or clicking on the 'Click to Select output' icon at the bottom right corner of the block to bring up the connection dialogue, and clicking on the required parameter. Recommended connections are shown with a green plug symbol; other parameters which are available being shown in yellow. Clicking on the red button causes all parameters to be shown. To dismiss the connection dialogue either press the escape key on the keyboard, or click the cross at the bottom left of the dialogue box.
3. Once the wire has started a dashed wire is drawn from the output to the current mouse position. To complete the wire click on the required destination parameter.
4. Wires remain dashed until they are downloaded

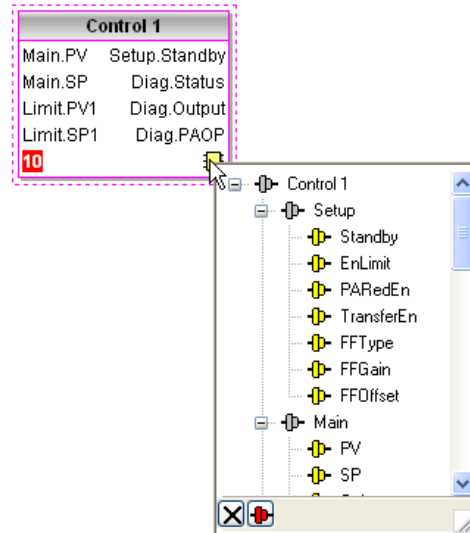

Figure 7.3.2c Output selection dialogue box

Routing wires

When a wire is placed it is auto-routed. The auto routing algorithm searches for a clear path between the two blocks. A wire can be auto-routed again using the context menus or by double clicking the wire. A wire segment can be edited manually by click-dragging. If the block to which it is connected is moved, the end of the wire moves with it, retaining as much of the path as possible.

If a wire is selected by clicking on it, it is drawn with small boxes on its corners.

Wire Context Menu

Right click on a wire to display the wire block context menu:

Force Exec Break	When wires form a loop, a break point must be introduced, where the value written to the block comes from a source which was last executed during the previous cycle. A break is automatically placed by iTools, and appears in red. Force Exec Break allows the user to define where a break must be placed. Surplus breaks appear in black.
Task Break	Each Network block, and associated I/O blocks, wiring etc. represents a 'task', which is normally associated with a particular power phase (Network Block one is associated with phase one, Network Block two with phase two and so on). Different tasks are thus often synchronised with different phases. A task break ensures that for any wiring between tasks, the timing is delayed as necessary to avoid phasing problems. Task breaks appear in blue.
Re-Route wire	Replaces the current wire route with a new route generated from scratch.
Use Tags	Toggles between wire and tag mode between parameters. Tag mode is useful for sources and destinations which are widely separated.
Find Start	Goes to the source of the wire.
Find End	Goes to the destination of the wire.
Cut, Copy, Paste	Not used in this context.

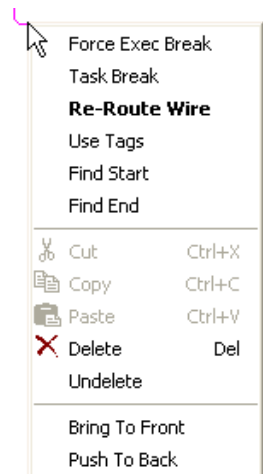

Figure 7.3.2d Wire Context Menu

7.3.2 WIRING EDITOR OPERATING DETAILS (Cont.)

WIRE CONTEXT MENU (Cont.)

Delete	Marks the wire for deletion. The wire is redrawn as a dashed line (or dashed tags) until next download. Operation can be reversed until after next download.
Undelete	Reverses the effect of the Delete operation up until the next download, after which, Undelete is disabled.
Bring to Front	Brings the wire to the front of the diagram.
Push to Back	Sends the wire to the back of the diagram.

Wire Colours

Black	Normal functioning wire
Red	The wire is connected to a non-changeable parameter. Values are rejected by the destination block.
Magenta	A normal functioning wire is being hovered-over by the mouse cursor.
Purple	A red wire is being hovered-over by the mouse cursor.
Green	New Wire (dashed green wire changes to solid black after being downloaded.)

THICK WIRES

When attempting to wire between blocks which are located in different tasks, if no task break is inserted, then all the affected wires are highlighted by being drawn with a much thicker line than usual. Thick wires still execute, but the results are unpredictable, as the unit cannot resolve the strategy.

COMMENTS

Comments are added to a wiring diagram by click-dragging them from the Function Block tree onto the diagram. As soon as the mouse is released, a dialogue box opens to allow the comment text to be entered. Carriage returns are used to control the width of the comment. Once text entry is complete, 'OK' causes the comment to appear on the diagram. There are no restrictions on the size of a comment. Comments are saved to the instrument along with the diagram layout information.

Comments can be linked to function blocks and wires by clicking on the chain icon at the bottom right-hand corner of the comment box and then clicking again on the required block or wire. A dashed line is drawn to the top of the block or to the selected wire segment (figure 7.3.2f).

Note: once the comment has been linked, the Chain icon disappears. It re-appears when the mouse cursor is hovered over the bottom right-hand corner of the comment box, as shown in figure 7.3.2f, below.

Comment Context Menu

Edit	Opens the Comment dialogue box to allow the comment text to be edited.
Unlink	Deletes the current link from the comment.
Cut	Moves the comment to the Clipboard, ready to be pasted elsewhere. Short cut = <ctrl>+<X>.
Copy	Copies the comment from the wiring diagram to the Clipboard, ready to be pasted elsewhere. Short cut = <ctrl>+<C>.
Paste	Copies a comment from the Clipboard to the wiring diagram. Short cut = <ctrl>+<V>.
Delete	Marks the comment for deletion at next download.
Undelete	Undoes the Delete command if download has not taken place since.

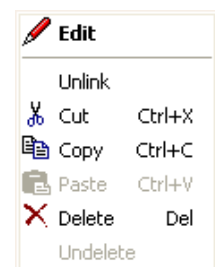

Figure 7.3.2e
Comment context menu

7.3.2 WIRING EDITOR OPERATING DETAILS (Cont.)

MONITORS

Monitor points are added to a wiring diagram by click-dragging them from the Function Block tree onto the diagram. A monitor shows the current value (updated at the iTools parameter list update rate) of the parameter to which it is linked. By default the name of the parameter is shown. To hide the parameter name either double click on the monitor box or 'Show Names' in the context (right-click) menu can be used to toggle the parameter name on and off.

Monitors are linked to function blocks and wires by clicking on the chain icon at the bottom right-hand corner of the box and then clicking again on the required parameter. A dashed line is drawn to the top of the block or the selected wire segment.

Note: once the monitor has been linked, the Chain icon disappears. It re-appears when the mouse cursor is hovered over the bottom right-hand corner of the monitor box.

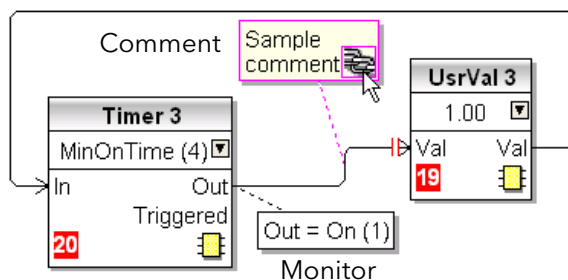

Figure 7.3.2f Comment and Monitor appearance

Monitor Context Menu

Show names	Toggles parameter names on and off in the monitor box.
Unlink	Deletes the current link from the monitor.
Cut	Moves the monitor to the Clipboard, ready to be pasted elsewhere. Short cut = <ctrl>+<X>.
Copy	Copies the monitor from the wiring diagram to the Clipboard, ready to be pasted elsewhere. Short cut = <ctrl>+<C>.
Paste	Copies a monitor from the Clipboard to the wiring diagram. Short cut = <ctrl>+<V>.
Delete	Marks the monitor for deletion at next download.
Undelete	Undoes the Delete command if download has not taken place since.
Bring to Front	Moves the item to the 'top' layer of the diagram.
Push to Back	Moves the item to the 'bottom' layer of the diagram.
Parameter Help	Shows parameter help for the item.

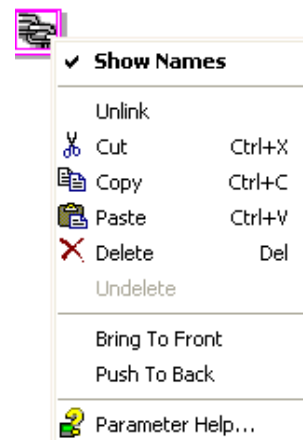

Figure 7.3.2g
Monitor context menu

DOWNLOADING

When the wiring editor is opened the current wiring and diagram layout is read from the instrument. No changes are made to the instrument function block execution or wiring until the download button is pressed. Any changes made using the operator interface after the editor is opened are lost on download.

When a block is dropped onto the diagram, instrument parameters are changed to make the parameters for that block available. If changes are made and the editor is closed without saving them there is a delay while the editor clears these parameters.

During download, the wiring is written to the instrument which then calculates the block execution order and starts executing the blocks. The diagram layout including comments and monitors is then written into instrument flash memory along with the current editor settings. When the editor is reopened, the diagram is shown positioned as it was when it was last downloaded.

7.3.2 WIRING EDITOR OPERATING DETAILS (Cont.)

COLOURS

Items on the diagram are coloured as follows:

Red	Items which totally or partially obscure other items and items which are totally or partially obscured by other items. Wires that are connected to unalterable or non-available parameters. Execution breaks. Block execution orders for Task 1.
Blue	Non-available parameters in function blocks. Block execution orders for Task 4. Task breaks.
Green	Items added to the diagram since last download are shown as green dashed lines. Block execution orders for Task 2.
Magenta	All selected items, or any item over which the cursor is hovering.
Purple	Red wires when being hovered over by the mouse cursor.
Black	All items added to the diagram before the last download. Block execution orders for Task 3. Redundant execution breaks. Monitor and comment text.

DIAGRAM CONTEXT MENU

Cut	Active only when the right click occurs within the bounding rectangle which appears when more than one item is selected. Moves the selection off the diagram to the Clipboard. Short cut = <ctrl>+<X>.
Copy	As for 'Cut', but the selection is copied, leaving the original on the diagram. Short cut = <ctrl>+<C>.
Paste	Copies the contents of the Clipboard to the diagram. Short cut = <ctrl>+<V>.
Re-Route wires	Reroutes all selected wires. If no wires are selected, all wires are re-routed.
Align Tops	Aligns the tops of all blocks in the selected area.
Align Lefts	Aligns the left edges of all blocks in the selected area.
Space Evenly	Spaces selected items such that their top left corners are spaced evenly across the width of the diagram. Click on the item which is to be the left-most item, then <ctrl>+<left click> the remaining items in the order in which they are to appear.
Delete	Marks the item for deletion at next download time. Can be 'Undeleted' up until download occurs.
Undelete	Reverses the action of 'Delete' on the selected item.
Select All	Selects all items on the current diagram.
Create Compound	Active only when the right click occurs, in the top level diagram, within the bounding rectangle which appears when more than one item is selected. Creates a new wiring diagram as described in 'Compound', below.
Rename	Allows a new name to entered for the current wiring diagram. This name appears in the relevant tab.

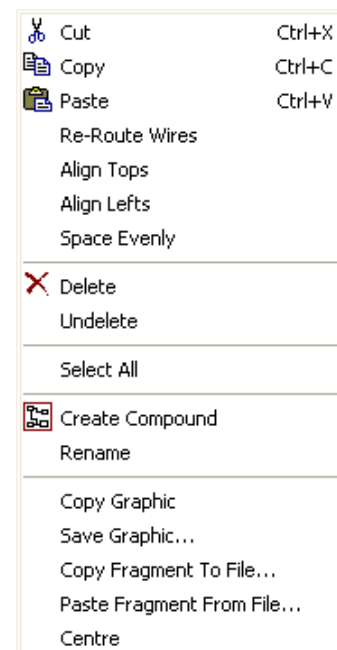

Figure 7.3.2h
Diagram context menu

Copy Graphic	Copies the selected items (or the whole diagram if no items are selected) to the clipboard as a Windows metafile, suitable for pasting into a documentation application. Wiring entering/leaving the selection (if any) are drawn in tag mode.
Save Graphic...	As for 'Copy Graphic' above, but saves to a user-specified file location instead of the clipboard.
Copy Fragment To File...	Copies selected items to a user-named file in folder 'My iTools Wiring Fragments' located in 'My Documents'.
Paste Fragment From File	Allows the user to select a stored fragment for inclusion in the wiring diagram.
Centre	Places the display window at the centre of the selected items. If 'Select All' has previously been clicked-on, then the display widow is placed over the centre of the diagram.

7.3.2 WIRING EDITOR OPERATING DETAILS (Cont.)

COMPOUNDS

Compounds are used to simplify the top level wiring diagram, by allowing the placing of any number of function blocks within one 'box', the inputs and outputs of which operate in the same way as those of a normal function block.

Each time a compound is created, a new tab appears at the top of the wiring diagram. Initially compounds and their tabs are named 'Compound 1', 'Compound 2', etc. but they can be renamed by right clicking either on the compound in the top level diagram, or anywhere within an open Compound, selecting 'Rename' and typing in the required text string (16 characters max.).

Compounds cannot contain other compounds (i.e. they can be created only in the top level diagram).

Compound creation

1. Empty compounds are created within the top level diagram by clicking on the 'Create Compound' toolbar icon.
2. Compounds can also be created by highlighting one or more function blocks in the top level diagram and then clicking on the 'Create Compound' toolbar icon. The highlighted items are moved from the top level diagram into a new compound.
3. Compounds are 'uncreated' (flattened), by highlighting the relevant item in the top level menu and then clicking on the 'Flatten Compound' toolbar icon. All the items previously contained within the compound appear on the top level diagram.
4. Wiring between top level and compound parameters is carried out by clicking on the source parameter, then clicking on the compound (or the compound tab) and then clicking on the destination parameter. Wiring from a compound parameter to a top level parameter or from compound to compound is carried out in similar manner.
5. Unused function blocks can be moved into compounds by dragging from the tree view. Existing blocks can be dragged from the top level diagram, or from another compound, onto the tab associated with the destination compound. Blocks are moved out of compounds to the top level diagram or to another compound in a similar way. Function blocks can also be 'cut and pasted'.
6. Default compound names (e.g. 'Compound 2') are used only once, so that if, for example, Compounds 1 and 2 have been created, and Compound 2 is subsequently deleted, then the next compound to be created will be named 'Compound 3'.
7. Top level elements can be click-dragged into compounds.



7.3.2 WIRING EDITOR OPERATING DETAILS (Cont.)

TOOL TIPS

Hovering the cursor over the block displays 'tooltips' describing that part of the block beneath the cursor. For function block parameters the tooltip shows the parameter description, its OPC name, and, if downloaded, its value. Similar tooltips are shown when hovering over inputs, outputs and over many other items on the iTools screen.

A Function Block is enabled by dragging the block onto the diagram, wiring it, and finally downloading it to the instrument. Initially blocks and associated wires are drawn with dashed lines, and when in this state the parameter list for the block is enabled but the block is not executed by the instrument.

The block is added to the instrument function block execution list when the 'Download' icon is operated and the items are redrawn using solid lines.

If a block which has been downloaded is deleted, it is shown on the diagram in a ghosted form until the download button is pressed. (This is because it and any wires to/from it are still being executed in the instrument. On download it will be removed from the instrument execution list and the diagram.) A ghosted block can be 'undeleted' as described in 'Context menu', above.

When a dashed block is deleted it is removed immediately.

7.4 PARAMETER EXPLORER

This view is displayed:

1. by clicking on the 'Parameter Explorer' toolbar icon,  Parameter Explorer
2. by double clicking on the relevant block in the tree pane or in the graphical wiring editor
3. by selecting 'Function Block View' from the Function block context menu in the Graphical wiring Editor.
4. by selecting 'parameter Explorer from the 'View' menu
5. by using the short cut <Alt>+<Enter>

In each case the function block parameters appear in the iTools window in tabular form, such as the example in figure 7.4a, below.

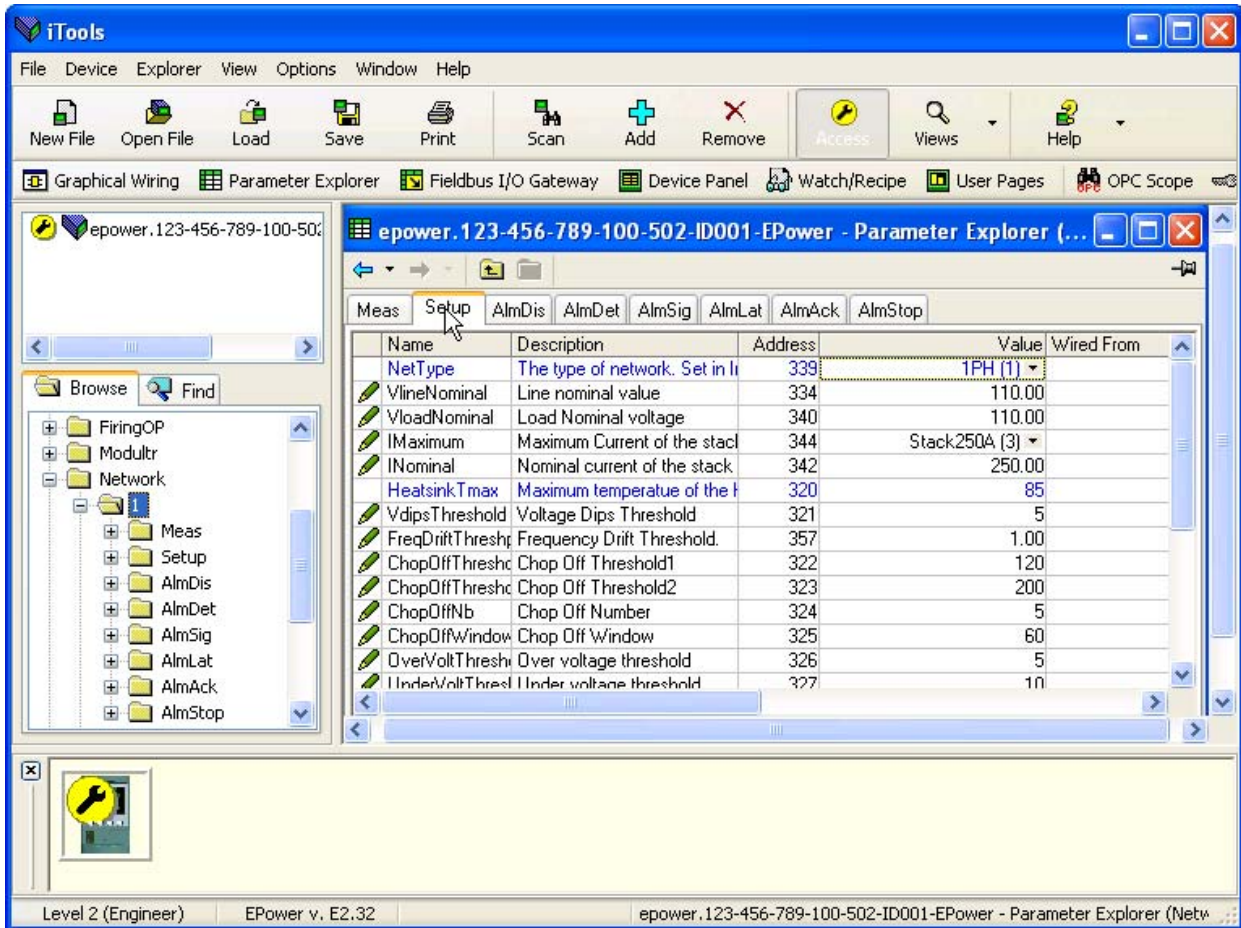

Figure 7.4a Parameter table example

The figure above shows the default table layout. Columns can be added/deleted from the view using the 'Columns' item of the Explorer or context menus (figure 7.4b).

7.4 PARAMETER EXPLORER (Cont.)

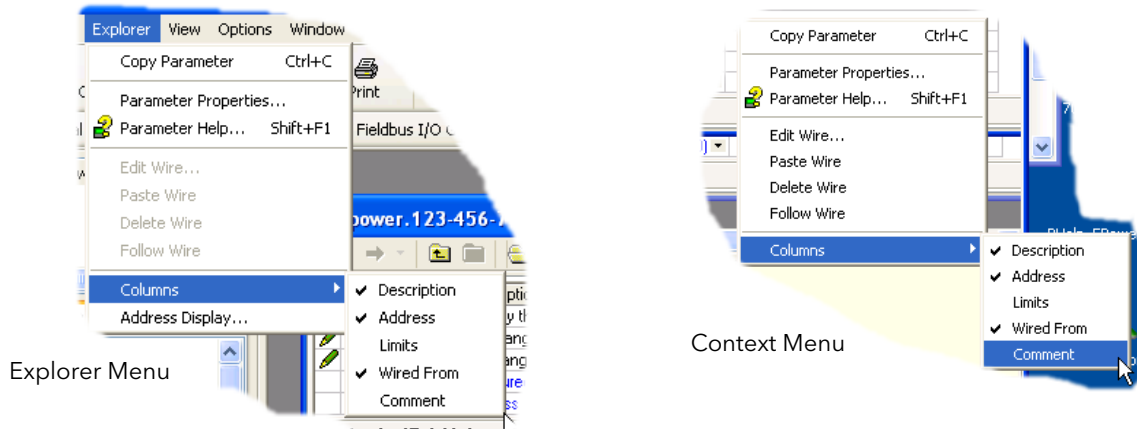

Figure 7.4b Column enable/disable

7.4.1 Parameter explorer detail

Figure 7.4.1a shows a typical parameter table. This particular parameter has a number of subfolders associated with it, and each of these is represented by a 'tab' across the top of the table.

Name	Description	Address	Value	Low Limit	High Limit	Wired From
Frequency	Frequency of the line	304	0.00	-10000000000.00	10000000000.00	
Vline	Line voltage measurement	256	0.00	-10000000000.00	10000000000.00	
I	Irms of the load	262	0.00	-10000000000.00	10000000000.00	
IsqBurst	Average square value of load	270	0.00	-10000000000.00	10000000000.00	
Isq	Square value of the load cur	272	0.00	-10000000000.00	10000000000.00	
V	Vrms of the load	276	0.00	-10000000000.00	10000000000.00	
VsqBurst	Average square value of the	306	0.00	-10000000000.00	10000000000.00	
Vsq	Square value of load voltage	284	0.00	-10000000000.00	10000000000.00	
PBurst	True Power measurement in	288	0.00	-10000000000.00	10000000000.00	
P	True power measurement.	290	0.00	-10000000000.00	10000000000.00	
S	Apparent power measuremer	292	0.00	-10000000000.00	10000000000.00	
PF	Power Factor	294	0.00	-10000000000.00	10000000000.00	
Q	Reactive Power	296	0.00	-10000000000.00	10000000000.00	
Z	Load impedance	298	3.40282346638529024E38	-10000000000.00	10000000000.00	

Figure 7.4.1a Typical parameter table

Notes:

- Parameters in blue are non-editable (Read only). In the example above all the parameters are read only. Read/write parameters are in black and have a 'pencil' symbol in the 'read/Write access column at the left edge of the table. A number of such items are shown in figure 7.4a, above.
- Columns. The default explorer window (figure 7.4a) contains the columns 'Name', 'Description', 'Address', 'Value', and 'Wired From'. As can be seen from figure 7.4b, the columns to be displayed can be selected, to a certain extent, using either the 'Explorer' menu or the context menu. 'Limits' have been enabled for the example above.
- Hidden Parameters. By default, iTools hides parameters which are considered irrelevant in the current context. Such hidden parameters can be shown in the table using the 'Parameter availability' settings item of the options menu (figure 7.4b). Such items are displayed with a shaded background.
- The full pathname for the displayed parameter list is shown at the bottom left hand corner of the window.

7.4.1 PARAMETER EXPLORER DETAIL (Cont.)

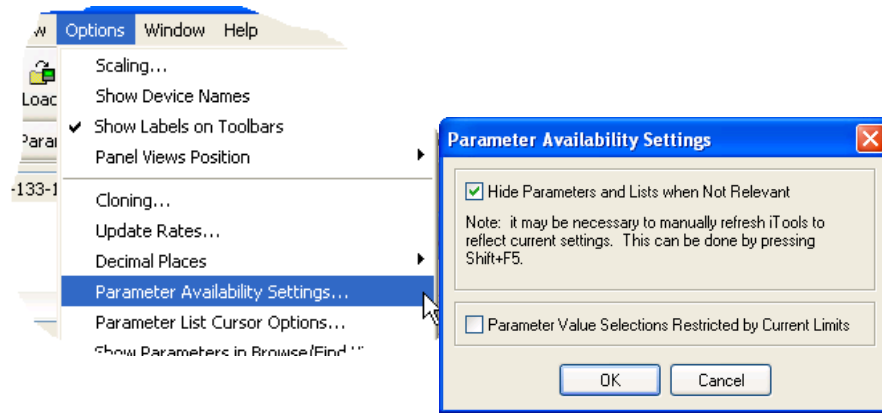

Figure 7.4.1b Show/Hide parameters



Back to: and Forward to: The parameter explorer contains a history buffer of up to 10 lists that have been browsed in the current instance of the window. The 'Back to: (list name)' and 'Forward to: (list name)' icons allow easy retracing or repeating of the parameter list view sequence.

If the mouse cursor is hovered over the tool icon, the name of the parameter list which will appear if the icon is clicked-on appears. Clicking on the arrow head displays a pick list of up to 10 previously visited lists which the user can select. Short cut = <ctrl>+ for 'Back to' or <ctrl>+<F> for 'Forward to'.



Go Up a Level, Go Down a Level. For nested parameters, these buttons allow the user to navigate 'vertically' between levels. Short cut = <ctrl>+<U> for 'Go Up a Level' or <ctrl>+<D> for 'Go Down a Level'.



Push pin to give the window global scope. Clicking on this icon causes the current parameter list to be permanently displayed, even if another instrument becomes the 'current device'.

7.4.2 Explorer tools

A number of tool icons appear above the parameter list: Context Menu

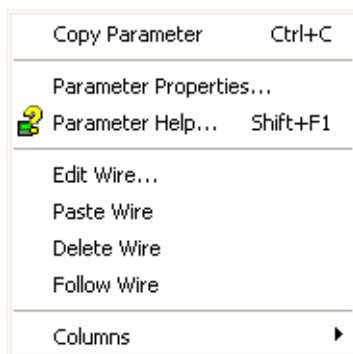

Copy Parameter
Parameter properties
Parameter Help...
Edit/Paste/Delete/Follow Wire
Columns

Copies the clicked-on parameter to the clipboard
Displays parameter properties for the clicked-on parameter
Displays help information for the clicked-on parameter
Not used in this application
Allows the user to enable/disable a number of parameter table columns (figure 7.4b).

7.5 FIELDBUS GATEWAY Fieldbus I/O Gateway

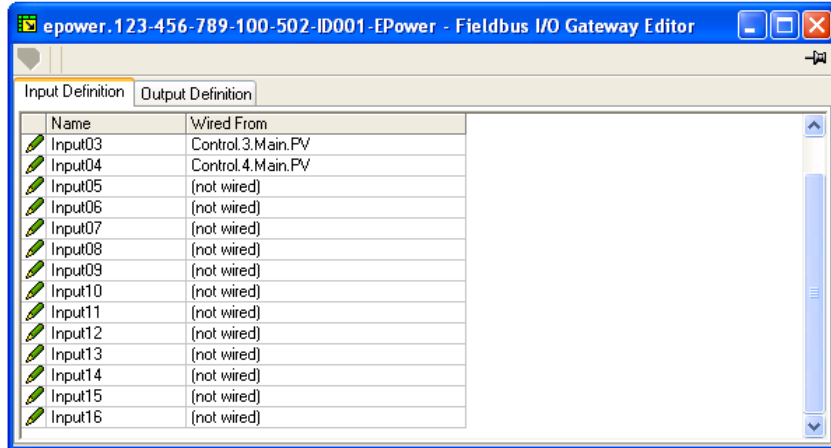

Figure 7.5a Typical Fieldbus Gateway Parameter list

A Profibus master may be required to work with slaves from different manufacturers and with different functions. Also, there are many parameters which are not required by the network master. Fieldbus Gateway allows the user to define which Input and output parameters are to be available over the Profibus link. The master may then map the selected device parameters into, for example, PLC input/output registers, or, in the case of a supervisory (SCADA) package, to a personal computer.

Values from each slave, (the 'Input Data'), are read by the master, which then runs a control program such as a ladder logic program. The program generates a set of values, (the 'Output Data') and loads them into a pre-defined set of registers for transmission to the slaves. This process is called an 'I/O data exchange' and is repeated continuously, to give a cyclical I/O data exchange.

As shown in figure 7.5a, above, there are two tabs within the editor, called 'Input definition' and 'Output definition'. 'Inputs' are values sent from the controller to the Profibus master. 'Outputs' are values received from the master and used by the controller, (e.g. set points written from the master).

Note: Values from Profibus over write changes made at the operator interface.

The procedure for selecting variables is the same for both input and output definition tabs:

1. Double click the next available position in the input or output data table and select the variable to assign to it. A pop-up (figure 7.5b) provides a browser from which a list of parameters can be opened.
2. Double click the parameter to assign it to the input definition.

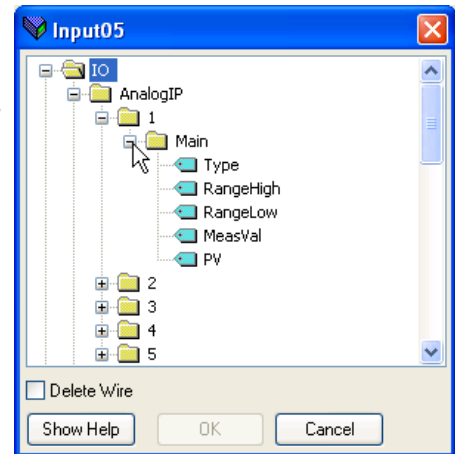

Figure 7.5b Browser window

Note: Gaps may be left in the table if so desired.

7.5 FIELDBUS GATEWAY(Cont.)

When all the required parameters have been added to the lists, notes of how many 'wired' entries are included in the input and output areas should be made as this information is needed when setting up the Profibus Master.

Notes:

1. A maximum of 32 input and 16 output parameters may be set using the Gateway Editor.
2. No checks are made that output variables are writeable, and if a read only variable is included in the output list any values sent to it will be ignored with no error indication.
3. For Modbus only:

As shown in figure 7.5b, 'Block Read' and 'Block Write' requests both access the same memory location (0C06), which 'points' to the relevant input definition table or output definition table according to whether the instruction is a read or a write. If a value is written to a parameter at a particular location in the output definition table, and the value of the parameter in the same location in the input definition table is then read, the read value is normally different from the write value because the parameter at a location in the input table is not usually the same as the parameter at that location in the output table (unless the same parameter is placed at the same location in both tables).

Once the changes have been made to the Input and Output definition lists, they must be downloaded to the controller unit. This is done (for both tables simultaneously) by clicking on the 'Update device Flash Memory' button on the top left of the Fieldbus Gateway Editor window. The controller performs a restart after this operation. 

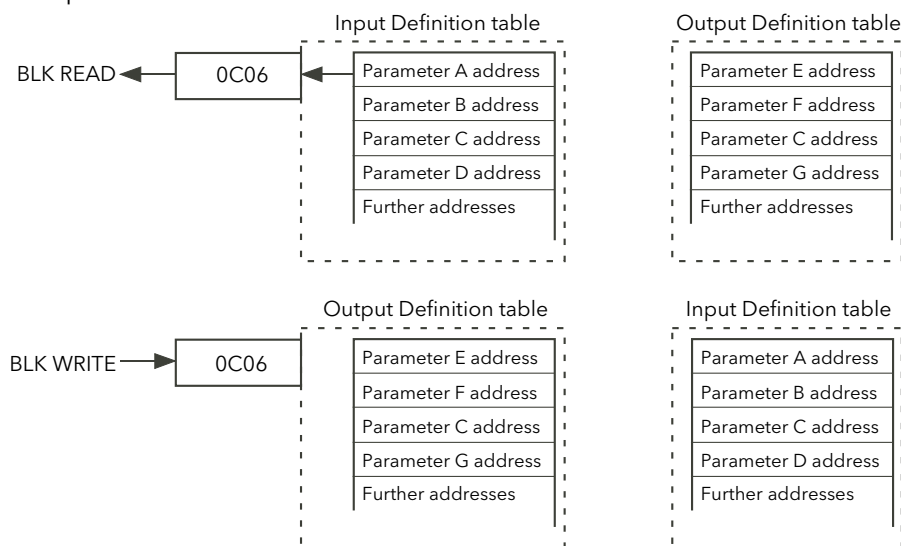

Figure 7.5b Block read and block write (note 3)

EE CHECKSUM FAIL ERROR

CAUTION

For software versions prior to version 3 only.

The EEPROM, used to retain configuration parameters whilst power is off, has a lifetime of at least 100,000 writes. If the Fieldbus Gateway is configured to include such configuration parameters (see list below), then the lifetime of the EEPROM may be reduced. In this case an 'EE Checksum Fail Error' message appears at power up, and the Driver Module will fail to start, and will have to be replaced.

It is therefore recommended that an alternative method is used when communicating with these parameters. For example, rather than writing directly to the parameter Control.MainSP (saved in EEPROM) it is possible to use a SetProv block and write into SetProv.Remote 1 (not saved in EEPROM) instead.

For software version 3.0 onwards, no parameters modified via the I/O Gateway will be saved in EEPROM. Saving to EEPROM will be achieved by other wiring methods.

7.5 FIELD BUS GATEWAY (Cont.)

EE CHECKSUM FAIL ERROR (Cont.)

The following is a list of parameters which are stored in EEPROM, and which should therefore not be included in the I/O Gateway configuration.

Access.ClearMemory
 Access.ConfigurationPasscode
 Access.EngineerPasscode
 Access.IM
 Access.Keylock
 Access.QuickStartPasscode
 AlmDis.Alarm.ExternIn
 AlmDis.AnalogOP.OutputFault
 AlmDis.Control.ClosedLoop
 AlmDis.Control.Limitation
 AlmDis.Control.PVTransfer
 AlmDis.LTC.Fuse
 AlmDis.LTC.Temp
 AlmDis.Network.ChopOff
 AlmDis.Network.FreqFault
 AlmDis.Network.FuseBlown
 AlmDis.Network.MainsVoltFault
 AlmDis.Network.MissMains
 AlmDis.Network.NetworkDips
 AlmDis.Network.OpenThyr
 AlmDis.Network.OverCurrent
 AlmDis.Network.OverTemp
 AlmDis.Network.PB24VFail
 AlmDis.Network.PLF
 AlmDis.Network.PLU
 AlmDis.Network.PreTemp
 AlmDis.Network.ThyrSC
 AlmDis.Network.TLF
 AlmDis.PLM.PrOverPs
 AlmLat.Alarm.ExternIn
 AlmLat.AnalogOP.OutputFault
 AlmLat.Control.ClosedLoop
 AlmLat.Control.Limitation
 AlmLat.Control.PVTransfer
 AlmLat.LTC.Fuse
 AlmLat.LTC.Temp
 AlmLat.Network.FreqFault
 AlmLat.Network.FuseBlown
 AlmLat.Network.MainsVoltFault
 AlmLat.Network.MissMains
 AlmLat.Network.NetworkDips
 AlmLat.Network.OverCurrent
 AlmLat.Network.OverTemp
 AlmLat.Network.PB24VFail
 AlmLat.Network.PLF
 AlmLat.Network.PLU
 AlmLat.Network.PreTemp
 AlmLat.Network.ThyrSC
 AlmLat.Network.TLF
 AlmLat.PLM.PrOverPs
 AlmStop.Alarm.ExternIn
 AlmStop.AnalogOP.OutputFault
 AlmStop.Control.ClosedLoop
 AlmStop.Network.MainsVoltFault
 AlmStop.Network.PLF
 AlmStop.Network.PLU
 AlmStop.Network.PreTemp

AlmStop.Network.TLF
 AnSwitch.Fallback
 AnSwitch.FallbackVal
 AnSwitch.HighLimit
 AnSwitch.In1
 AnSwitch.In2
 AnSwitch.In3
 AnSwitch.In4
 AnSwitch.In5
 AnSwitch.In6
 AnSwitch.In7
 AnSwitch.In8
 AnSwitch.LowLimit
 AnSwitch.Select
 Counter.Clock
 Counter.Direction
 Counter.Enable
 Counter.Target
 Digital.Invert
 Digital.Type
 Energy.AutoScaleUnits
 Energy.PulseLen
 Energy.PulseScale
 Energy.TotEnergyUnit
 Energy.Type
 Energy.UsrEnergyUnit
 Faultdet.GlobalDis
 FiringOP.DelayedTrigger
 FiringOP.LoadType
 FiringOP.SafetyRamp
 FiringOP.SoftStart
 FiringOP.SoftStop
 IPMonitor.AlarmDays
 IPMonitor.AlarmTime
 IPMonitor.In
 IPMonitor.Threshold
 Lgc2.FallbackType
 Lgc2.Hysteresis
 Lgc2.In1
 Lgc2.In2
 Lgc2.Invert
 Lgc2.Oper
 Lgc8.In1
 Lgc8.In2
 Lgc8.In3
 Lgc8.In4
 Lgc8.In5
 Lgc8.In6
 Lgc8.In7
 Lgc8.In8
 Lgc8.InInvert
 Lgc8.NumIn
 Lgc8.Oper
 Lgc8.OutInvert
 Limit.Control.SP1
 Limit.Control.SP2
 Limit.Control.SP3

7.5 FIELD BUS GATEWAY (Cont.)

EE CHECKSUM FAIL ERROR (Cont.)

Limit.Control.TI
 Main.AnalogIP.RangeHigh
 Main.AnalogIP.RangeLow
 Main.AnalogIP.Type
 Main.AnalogOP.RangeHigh
 Main.AnalogOP.RangeLow
 Main.AnalogOP.Type
 Main.Control.SP
 Main.Control.TI
 Main.Control.TransferSpan
 Main.PLM.Period
 Main.PLM.Type
 MainPrm.LTC.S1
 MainPrm.LTC.S2
 MainPrm.LTC.S3
 MainPrm.LTC.TapNb
 MainPrm.LTC.Type
 Math2.Fallback
 Math2.FallbackVal
 Math2.HighLimit
 Math2.In1
 Math2.In1Mul
 Math2.In2
 Math2.In2Mul
 Math2.LowLimit
 Math2.Oper
 Math2.Resolution
 Math2.Select
 Math2.Units
 Modultr.CycleTime
 Modultr.LgcMode
 Modultr.MinOnTime
 Modultr.Mode
 Modultr.SwitchPA
 Network.PLM.Ps
 PLMChan
 PLMChan.Group
 PLMChan.ShedFactor
 RmtPanel.Comms.Address
 RmtPanel.Comms.Baud
 SetProv.DisRamp
 SetProv.HiRange
 SetProv.Limit
 SetProv.LocalSP
 SetProv.RampRate
 SetProv.RemSelect
 SetProv.SPSelect
 SetProv.SPTrack
 SetProv.SPUnits
 Setup.Control.BleedScale
 Setup.Control.EnLimit
 Setup.Control.FFGain
 Setup.Control.FFOffset
 Setup.Control.FFType
 Setup.Control.NominalPV
 Setup.Control.TransferEn
 Setup.Network.ChopOffNb
 Setup.Network.ChopOffThreshold1
 Setup.Network.ChopOffThreshold2
 Setup.Network.ChopOffWindow
 Setup.Network.FreqDriftThreshold

Setup.Network.HeaterType
 Setup.Network.HeatsinkPreTemp
 Setup.Network.IextScale
 Setup.Network.IMaximum
 Setup.Network.INominal
 Setup.Network.OverIThreshold
 Setup.Network.OverVoltThreshold
 Setup.Network.PLFSensitivity
 Setup.Network.PLUthreshold
 Setup.Network.UnderVoltThreshold
 Setup.Network.VdipsThreshold
 Setup.Network.VextScale
 Setup.Network.VlineNominal
 Setup.Network.VloadNominal
 Setup.Network.VMaximum
 Station.PLM.Address
 Timer.In
 Timer.Time
 Timer.Type
 Total.AlarmSP
 Total.Hold
 Total.In
 Total.Reset
 Total.Resolution
 Total.Run
 Total.Units
 User.Comms.Address
 User.Comms.Baud
 User.Comms.DCHP_enable
 User.Comms.Default_Gateway_1
 User.Comms.Default_Gateway_2
 User.Comms.Default_Gateway_3
 User.Comms.Default_Gateway_4
 User.Comms.Delay
 User.Comms.Extension_Cycles
 User.Comms.IP_address_1
 User.Comms.IP_address_2
 User.Comms.IP_address_3
 User.Comms.IP_address_4
 User.Comms.Network_Version
 User.Comms.Parity
 User.Comms.Pref_Mstr_IP_1
 User.Comms.Pref_Mstr_IP_2
 User.Comms.Pref_Mstr_IP_3
 User.Comms.Pref_Mstr_IP_4
 User.Comms.Protocol
 User.Comms.ShowMac
 User.Comms.Subnet_Mask_1
 User.Comms.Subnet_Mask_2
 User.Comms.Subnet_Mask_3
 User.Comms.Subnet_Mask_4
 User.Comms.UnitIdent
 UsrVal.HighLimit
 UsrVal.LowLimit
 UsrVal.Resolution
 UsrVal.Status
 UsrVal.Units
 UsrVal.Val
 Wire.Dest
 Wire.Src

7.6 DEVICE PANEL Device Panel

When this toolbar icon is clicked on, a representation of the connected instrument (either on-line, or a clone) appears in the iTools window. The operator interface acts as in the real instrument (note 1), but instead of operating the push-buttons by hand, the relevant items are clicked on, using the mouse. Changes made at the operator interface are reflected at the iTools screen and *vice-versa*.

The display can be scaled as required by click/dragging on the sides/bottom or corners.

Notes:

1. An up/down arrow key appears above the display for operations (e.g. acknowledging system alarms) which require simultaneous operation of the up and down arrow keys. 
2. Real instruments can be recognised by the fact that the representation of the display is in green, whereas for cloned instruments, the display is shown in white (see figure 7.6 below).



Figure 7.6 Device panel display on-line (left) and clone (right).

7.7 WATCH/RECIPE EDITOR Watch/Recipe

The watch/recipe editor is opened by clicking on the Watch/Recipe tool icon, by selecting 'Watch/Recipe' in the 'Views' menu or by using the short cut <ctrl>+<A>. The window is in two parts: the left part containing the watch list; the right-hand part containing one or more data sets, initially empty and unnamed.

The Watch/Recipe window is used:

1. To monitor a list of parameters. This list can contain parameters from many different, and otherwise unrelated parameter lists within the same device. It cannot contain parameters from different devices.
2. To create 'data sets' of parameter values which can be selected and downloaded to the device in the sequence defined in the recipe. The same parameter may be used more than once in a recipe.

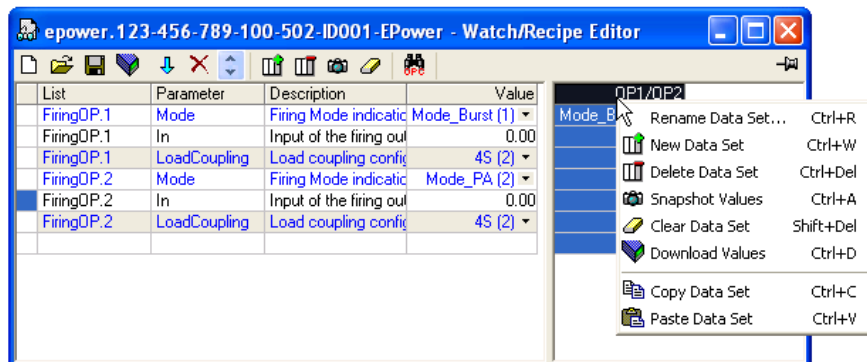



Figure 7.7 Watch/Recipe Editor window (with context menu)

7.7.1 Creating a Watch List

After opening the window, parameters can be added to it as described below. The values of the parameters update in real-time, allowing the user to monitor a number of values simultaneously.

ADDING PARAMETERS TO THE WATCH LIST

1. Parameters can be click-dragged into the watch list from another area of the iTools window (for example, the parameter explorer window, the graphical wiring editor, the browse tree). The parameter is placed either in an empty row at the bottom of the list, or if it is dragged on top of an already existing parameter, it is inserted above this parameter, with the remaining parameters being moved down one place.
2. Parameters can be dragged from one position in the list to another. In such a case, a copy of the parameter is produced, the source parameter remaining in its original position.
3. Parameters can be copied <ctrl>+<C> and pasted <ctrl>+<V> either within the list, or from a source external to it, for example the parameter browse window or the graphical wiring editor.
4. The 'Insert item...' tool button  the 'Insert Parameter' item in the Recipe or context menu or the short cut <Insert> can be used to open a browse window from which a parameter is selected for insertion above the currently selected parameter.

DATA SET CREATION

Once all the required parameters have been added to the list, select the empty data set by clicking on the column header. Fill the data set with current values using one of the following methods:

1. Clicking on the 'Capture current values into a data set' tool icon  (also known as the 'Snapshot Values' tool).
2. Selecting 'Snapshot Values' from the Recipe or Context (right-click) menu.
3. Using the short cut <ctrl>+<A>.

7.7.1 CREATING A WATCH LIST (Cont.)

DATA SET CREATION (Cont.)

Individual data values can now be edited by typing directly into the grid cells. Data values can be left blank or cleared, in which case, no values will be written for those parameters at download. Data values are cleared by deleting all the characters in the cell then either moving to a different cell or typing <Enter>.

The set is called 'Set 1' by default, but it can be renamed by either by using the 'Rename data set...' item in the Recipe or context menus, or by using the short cut <ctrl>+<R>.













New, empty data sets can be added using one of the following:

1. Clicking on the 'Create a new empty data set' toolbar icon. 
2. Selecting 'New Data Set' in the Recipe or context menus
3. Using the short cut <ctrl>+<W>

Once created, the data sets are edited as described above.

Finally, once all the required data sets have been created, edited and saved, they can be downloaded the instrument, one at a time, using the Download tool, the 'Download Values' item in the Recipe or context menus, or the short cut <ctrl>+<D>. 

7.7.2 Watch Recipe toolbar icons

-  Create a new watch/recipe list. Creates a new list by clearing out all parameters and data sets from an open window. If the current list has not been saved, confirmation is requested. Short cut <ctrl>+<N>
-  Open an existing watch/recipe file. If the current list or data set has not been saved, confirmation is requested. A file dialogue box then opens allowing the user to select a file to be opened. Short cut <ctrl>+<O>
-  Save the current watch/recipe list. Allows the current set to be saved to a user specified location. Short cut <ctrl>+<S>.
-  Download the selected data set to the device. Short cut <ctrl>+<D>
-  Insert item ahead of selected item. Short cut <Insert>.
-  Remove recipe parameter. Short cut <ctrl>+<Delete>.
-  Move selected item. Up arrow moves selected parameter up the list; down arrow move the selected parameter down the list.
-  Create a new empty data set. Short cut <ctrl>+<w>.
-  Delete an empty data set. Short cut <ctrl>+<Delete>
-  Capture current values into a data set. Fills the selected data set with values. Short cut <ctrl>+<A>.
-  Clear the selected data set. Removes values from the selected data set. Short cut <Shift>+<Delete>.
-  Open OPC Scope. Opens a separate utility that allows trending, data logging and Dynamic Data Exchange (DDE). OPC Scope is an OPC explorer program that can connect to any OPC server that is in the windows registry.
(OPC is an acronym for 'OLE for Process Control, where OLE stands for 'Object Linking and Embedding'.)

7.7.3 Watch/Recipe Context Menu

The Watch/Recipe Context menu items have the same functions as described above for toolbar items.

7.8 USER PAGES User Pages

Up to four user pages, each with four lines can be created and downloaded to the unit. These allow the operator interface to display particular sets of values, in various formats. Figure 7.8 below, shows the initial display when 'User Pages' is first clicked-on.

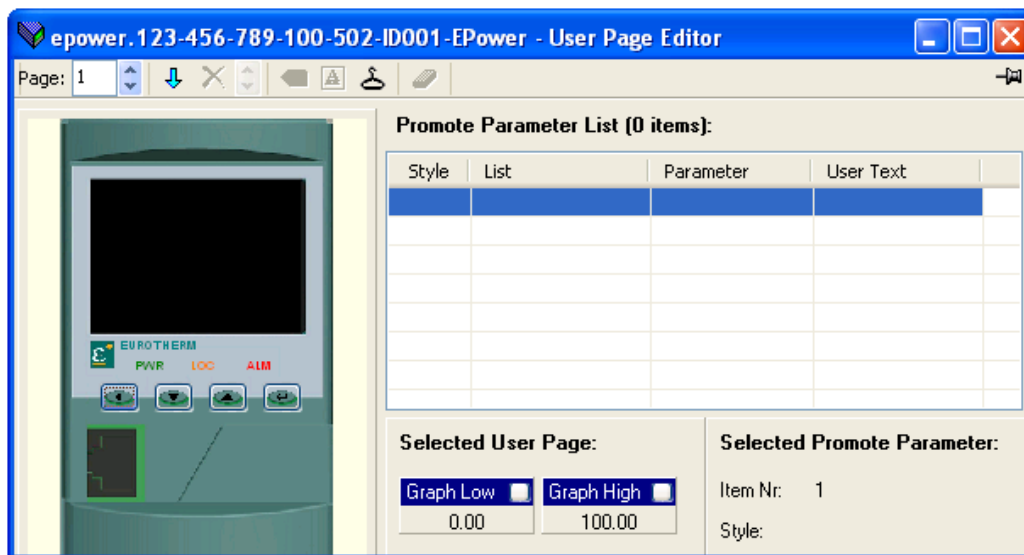

Figure 7.8 Blank User Page

7.8.1 User Page creation

1. Click on the up/down arrow to select the required Page number for configuration. Page:
2. Double-click one of the cells in the 'Promote Parameter List' to display the 'Select Item Style' window (figure 7.8.1a).
3. Click on the required style then on 'OK'.
4. A parameter Browse window appears (figure 7.8.1b) for the selected row (1 in the figure), allowing the user to select a parameter.
5. Click 'OK' to insert the parameter into the list.
6. If required, click on white square on the relevant 'Graph Low' or 'Graph High' title bar, and set the low and high values to appear with an associated bargraph (figure 7.8.1c).

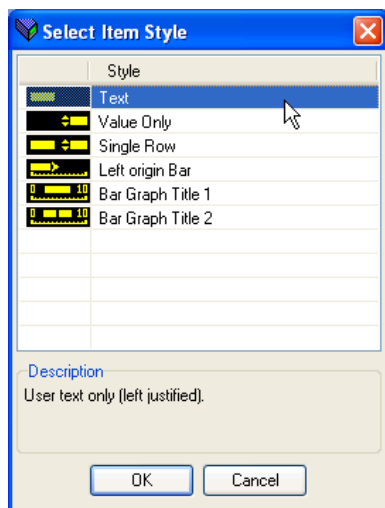

Figure 7.8.1a Style selection

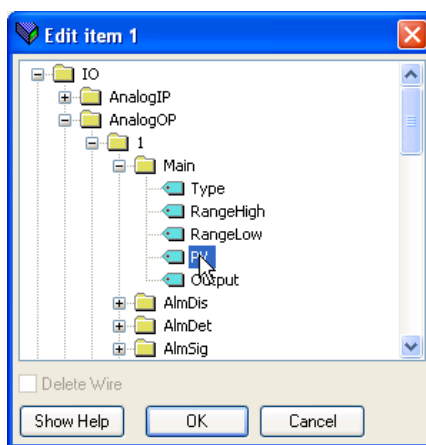

Figure 7.8.1b Parameter browse

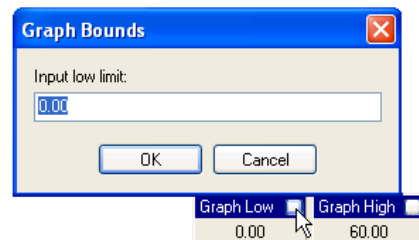

Figure 7.8.1c Graph limit setting.

7.8.2 Style examples



Figure 7.8.2a

Text, Value only, single Row and Left origin Bar styles









Figure 7.8.2b

Bar Graph Title 1, Left origin bar and Bar Graph Title 2 styles

Text	If 'Text' is selected, a text entry window appears allowing the user to enter the text to appear on the selected line of the display. The display can accommodate 10 characters - any further characters are hidden. This style is shown as line one in figure 7.8.2a.
Value only	Displays the value of the selected parameter, right justified. No User text may be entered for this style. This style is shown as line two in figure 7.8.2a.
Single Row	Displays the parameter mnemonic (left justified) and the parameter value (right justified). User text may be entered, but this will over-write the parameter mnemonic. This style is shown as line three in figure 7.8.2a.
Left origin Bar	Displays the parameter value as a left-hand zero bargraph. This style is shown as line four in figure 7.8.2a, and line two in figure 7.8.2b.
Bar Graph Title 1	Supplies low limit (left justified), parameter mnemonic (centred) and high limit (right justified) displays, normally associated with a Left origin Bar on the line below or above. User text may be entered. As the number of entered characters increases, this overwrites firstly the mnemonic, then the range values. This style is shown as line one in figure 7.8.2b.
Bar Graph Title 2	Similar to Bar Graph Title 1, but includes a numeric value for the parameter as well as its mnemonic. User text may be entered. As the number of entered characters increases, this overwrites firstly the mnemonic, then the range values. If the number of entered characters plus the number of value characters exceeds 10, then the user text is hidden, leaving just the parameter value. This style is shown as line three in figure 7.8.2b.

7.8.3 User Pages Tools

 Page: 1   Select Page. Use the up/down arrows to select page 1 to page 4 for configuration.

-  Insert item ahead of selected item. Opens a browser to allow the user to select a parameter for insertion in the table. The insertion point is above the currently selected item. If the Parameter list is full, the toolbar icon is disabled ('greyed out'). Short cut <Insert>
-  Remove selected item. Removes the selected item on the list (without confirmation). Short cut <ctrl>+<Delete>
-  Move selected item. Click on the arrows to change the parameter order, and thus the order in which the parameters appear at the operator interface.
-  Edit parameter for selected item. Opens a browser to allow the user to select a parameter to replace the highlighted parameter in the table. Short cut <ctrl>+<E>.
-  Edit user text for selected item. Allows the user to edit the user text which appears at the operator interface. Only the first 10 characters are displayed. For parameters that do not support user text ('no user text') appears in the 'User Text' column. Short cut <ctrl>+<T>.
-  Edit style for selected item. Clicking on this toolbar icon calls the Style Selection page allowing the user to edit the current style for the selected parameter. Short cut <ctrl>+<S>.
-  Remove all items from this page. After confirmation, this removes ALL items from the parameter list, not just the highlighted ones. Short cut <ctrl>+<X>.

Note: Most if the above functions are also to be found in the 'Pages' menu, in the context menu, along with 'Parameter Help' and 'Parameter properties...' items.

8 PARAMETER ADDRESSES (MODBUS)

8.1 INTRODUCTION

The iTools address fields display each parameter's Modbus address to be used when addressing integer values over the serial communications link. In order to access these values as IEEE floating point values, the calculation: IEEE address = {(Modbus address x 2) + hex 8000} should be used. The Communications manual HA179770 gives details of how to establish a suitable communications link.

Notes:

1. Certain parameters may have values which exceed the maximum value that can be read from or written to using a 16-bit integer communications. Such parameters have a scaling factor applied to them as described in section 8.3.
 2. When using 16-bit scaled integer modbus addressing, time parameters can be read from or written to in 10ths of minutes, or in 10ths of seconds as defined in the parameter [Instrument.config.TimerRes](#).
-

8.2 PARAMETER TYPES

The following parameter types are used:

bool	Boolean
uint8	Unsigned 8-bit integer
int16	Signed 16-bit integer
uint16	Unsigned 16-bit integer
int32	Signed 32-bit integer
uint32	Unsigned 32-bit integer
time32	Unsigned 32-bit integer (time in milliseconds)
float32	IEEE 32-bit floating point
string	String - an array of unsigned 8-bit integers.

8.3 PARAMETER SCALING

Some parameters might have values which exceed the maximum value (32767) that can be read/written via 16-bit scaled integer comms. For this reason, the following parameters are read/written with a scaling factor applied to them when using scaled integer comms:

Parameter Name	Scaling Factor
Network.1-4.Meas.PBurst	Kilo with 1 decimal place
Network.1-4.Meas.P	Kilo with 1 decimal place
Network.1-4.Meas.S	Kilo with 1 decimal place
Network.1-4.Meas.Q	Kilo with 1 decimal place
Network.1-4.Meas.IsqBurst	Kilo with 1 decimal place
Network.1-4.Meas.Isq	Kilo with 1 decimal place
Network.1-4.Meas.IsqMax	Kilo with 1 decimal place
Network.1-4.Meas.VsqBurst	Kilo with 1 decimal place
Network.1-4.Meas.Vsq	Kilo with 1 decimal place
Network.1-4.Meas.VsqMax	Kilo with 1 decimal place
PLM.Network.Pmax	Mega with 2 decimal places
PLM.Network.Pt	Mega with 2 decimal places
PLM.Network.Ps	Mega with 2 decimal places
PLM.Network.Pr	Mega with 2 decimal places
PLMChan.1-4.PZmax	Kilo with 1 decimal place

8.3.1 Conditional scaling

The parameters listed below are conditionally re-scaled as kilo values with 1 decimal place:

Parameter Name	Condition
Control.n.Setup.NominalPV	When Control.n.Main.PV is wired from Network.n.Meas.P, Vsq or Isq
Control.n.Main.PV	When wired from Network.n.Meas.P, Vsq or Isq
Control.n.Main.TransferPV	When wired from Network.n.Meas.P, Vsq or Isq
Control.n.Main.TransferSpan	When Control.n.Main.PV is wired from Network.n.Meas.P, Vsq or Isq
Control.n.Limit.PV1	When wired from Network.n.Meas.P, Vsq or Isq
Control.n.Limit.PV2	When wired from Network.n.Meas.P, Vsq or Isq
Control.n.Limit.PV3	When wired from Network.n.Meas.P, Vsq or Isq
Control.n.Limit.SP1	When Control.n.Limit.PV1 is wired from Network.n.Meas.P, Vsq or Isq
Control.n.Limit.SP2	When Control.n.Limit.PV2 is wired from Network.n.Meas.P, Vsq or Isq
Control.n.Limit.SP3	When Control.n.Limit.PV3 is wired from Network.n.Meas.P, Vsq or Isq
SetpProv.n.Remote1	When in Engineering units AND Control.m.Main.PV is wired from Network.m.Meas.P, Vsq or Isq (where m = the instance of the Control block to which SetpProv.n is wired)
SetpProv.n.Remote2	When in Engineering units AND Control.m.Main.PV is wired from Network.m.Meas.P, Vsq or Isq (where m = the instance of the Control block to which SetpProv.n is wired)
SetpProv.n.LocalSP	When in Engineering units AND Control.m.Main.PV is wired from Network.m.Meas.P, Vsq or Isq (where m = the instance of the Control block to which SetpProv.n is wired)

8.4 PARAMETER TABLE

The following table is arranged in alphabetical function block order:

Access	Firing O/P 4	IP Monitor 2	Predictive Load Manager
Comms	Instrument	IP Monitor 3	PLM Chan 1
Control 1	Analogue I/P 1	IP Monitor 4	PLM Chan 2
Control 2	Analogue I/P 2	LGC2 1	PLM Chan 3
Control 3	Analogue I/P 3	LGC2 2	PLM Chan 4
Control 4	Analogue I/P 4	LGC2 3	QuickStart
Counter 1	Analogue I/P 5	LGC2 4	Set Prov 1
Counter 2	Analogue O/P 1	Lgc8 1	Set Prov 2
Counter 3	Analogue O/P 2	Lgc8 2	Set Prov 3
Counter 4	Analogue O/P 3	Lgc8 3	Set Prov 4
Customer Page 1	Analogue O/P 4	Lgc8 4	Timer 1
Customer Page 2	I/O Digital 1	LTC	Timer 2
Customer Page 3	I/O Digital 2	Maths2 1	Timer 3
Customer Page 4	I/O Digital 3	Maths2 2	Timer 4
Energy 1	I/O Digital 4	Maths2 3	Totaliser 1
Energy 2	I/O Digital 5	Maths2 4	Totaliser 2
Energy 3	I/O Digital 6	Modulator 1	Totaliser 3
Energy 4	I/O Digital 7	Modulator 2	Totaliser 4
Energy 5	I/O Digital 8	Modulator 3	User Value 1
Event Log	I/O Relay 1	Modulator 4	User Value 2
Fault detection	I/O Relay 2	Network 1	User Value 3
Firing O/P 1	I/O Relay 3	Network 2	User Value 4
Firing O/P 2	I/O Relay 4	Network 3	
Firing O/P 3	IP Monitor 1	Network 4	

8.4 PARAMETER TABLE (Cont.)

Parameter path	Description	Type	Hex	Dec
Access.ClearMemory	Cold Start the Instrument	uint8	07EA	2026
Access.ConfigurationPasscode	Configuration Code (Default = 3)	int16	07E5	2021
Access.EngineerPasscode	Engineer Code (Default = 2)	int16	07E4	2020
Access.Goto	Goto	uint8	07E2	2018
Access.IM	Instrument Mode (0= Operating, 1 = Standby, 2 = Configuration)	uint8	00C7	199
Access.Keylock	Lock Instrument (0 = none, 1 = All, 2 = Edit)	uint8	07E9	2025
Access.Passcode	Passcode Request	int16	07E3	2019
Access.QuickStartPasscode	Quick Start Code (Default = 4)	int16	07E6	2022
Comms.RmtPanel.Address	Address (1 to 254)	uint8	0796	1942
Comms.RmtPanel.Baud	Baud Rate (0 = 9600, 1 = 19,200)	uint8	0797	1943
Comms.User.Address	Comms Address (Range depends on protocol)	uint8	076C	1900
Comms.User.Baud	Baud Rate (0 = 9600, 1 = 19,200, 2 = 4800, 3 = 2400, 4 = 1200 10 = 125kb, 250kb, 500kb, 13 = 1Mb)	uint8	076D	1901
Comms.User.DCHP_enable	DHCP Type (0 = fixed, 1 = dynamic)	bool	0780	1920
Comms.User.Default_Gateway_1	1st byte of Default Gateway	uint8	0778	1912
Comms.User.Default_Gateway_2	2nd byte of Default Gateway	uint8	0779	1913
Comms.User.Default_Gateway_3	3rd byte of Default Gateway	uint8	077A	1914
Comms.User.Default_Gateway_4	4th byte of Default Gateway	uint8	077B	1915
Comms.User.Delay	TX Delay time (0 = off, 1 = on)	uint8	076F	1903
Comms.User.Extension_Cycles	Number of CC Link Extension Cycles	uint8	0799	1945
Comms.User.Id	Comms Identity (0 = none, 1 = EIA485, 5 = Ethernet, 10 = Network)	uint8	076A	1898
Comms.User.IP_address_1	1st byte of IP address.	uint8	0770	1904
Comms.User.IP_address_2	2nd byte of IP address.	uint8	0771	1905
Comms.User.IP_address_3	3rd byte of IP address.	uint8	0772	1906
Comms.User.IP_address_4	4th byte of IP address.	uint8	0773	1907
Comms.User.MAC1	MAC address 1	uint8	0789	1929
Comms.User.MAC2	MAC address 2	uint8	078A	1930
Comms.User.MAC3	MAC address 3	uint8	078B	1931
Comms.User.MAC4	MAC address 4	uint8	078C	1932
Comms.User.MAC5	MAC address 5	uint8	078D	1933
Comms.User.MAC6	MAC address 6	uint8	078E	1934
Comms.User.NetStatus	Fieldbus Status	uint8	0795	1941
Comms.User.Network	Ethernet Network status	int16	0781	1921
Comms.User.Network_Version	CC Link Network Version	uint8	0798	1944
Comms.User.Occupied_Stations	Occupied Stations	uint8	079A	1946
Comms.User.Parity	Parity setting (0 = none, 1 = even, 2 = odd)	uint8	076E	1902
Comms.User.PNDevNum	Profibus station number	uint8	0C01	3073
Comms.User.PNinitMode	Profibus initialise mode	uint8	0C00	3072
Comms.User.Pref_Mstr_IP_1	1st byte of Preferred Master IP address	uint8	077C	1916
Comms.User.Pref_Mstr_IP_2	2nd byte of Preferred Master IP address	uint8	077D	1917
Comms.User.Pref_Mstr_IP_3	3rd byte of Preferred Master IP address	uint8	077E	1918
Comms.User.Pref_Mstr_IP_4	4th byte of Preferred Master IP address	uint8	077F	1919
Comms.User.Protocol	Comms Protocol (0 = Modbus, 5 = Ethernet, 10 = Network, 11 = Profibus, 12 = DeviceNet, 13 = CanOpen, 14 = CCLink, 15 = Profinet, 16 = Ethernet IP)	uint8	076B	1899
Comms.User.ShowMac	Show MAC address	bool	0788	1928
Comms.User.Subnet_Mask_1	1st byte of Subnet mask	uint8	0774	1908
Comms.User.Subnet_Mask_2	2nd byte of Subnet mask	uint8	0775	1909
Comms.User.Subnet_Mask_3	3rd byte of Subnet mask	uint8	0776	1910
Comms.User.Subnet_Mask_4	4th byte of Subnet mask	uint8	0777	1911
Comms.User.UnitIdent	Unit Identity Enable (0 = Strict, 1 = Loose, 2 = Instr.)	uint8	0787	1927
Control.1.AlmAck.ClosedLoop	Process alarm ack: Closed loop break (0 = No Ack, 1 = Ack)	uint8	03B7	951
Control.1.AlmAck.Limitation	Indication alarm ack: Limitation (0 = No Ack, 1 = Ack)	uint8	03B9	953

8.4 PARAMETER TABLE (Cont.)

Parameter path	Description	Type	Hex	Dec
Control.1.AlmAck.PVTransfer	Indication alarm ack: PV transfer (0 = No Ack, 1 = Ack)	uint8	03B8	952
Control.1.AlmDet.ClosedLoop	Process alarm detection status: Closed loop break (0 = Inactive, 1 = Active)	uint8	03AE	942
Control.1.AlmDet.Limitation	Indication alarm detection status: Limitation (0 = Inactive, 1 = Active)	uint8	03B0	944
Control.1.AlmDet.PVTransfer	Indication alarm detection status: PV transfer (0 = Inactive, 1 = Active)	uint8	03AF	943
Control.1.AlmDis.ClosedLoop	Process alarm: Closed loop break (0 = Enable, 1 = Disable)	uint8	03AB	939
Control.1.AlmDis.Limitation	Indication alarm: Limitation (0 = Enable, 1 = Disable)	uint8	03AD	941
Control.1.AlmDis.PVTransfer	Indication alarm: PV transfer (0 = Enable, 1 = Disable)	uint8	03AC	940
Control.1.AlmLat.ClosedLoop	Process alarm latch: Closed loop break (0 = No Latch, 1 = Latch)	uint8	03B4	948
Control.1.AlmLat.Limitation	Indication alarm latch: Limitation (0 = No Latch, 1 = Latch)	uint8	03B6	950
Control.1.AlmLat.PVTransfer	Indication alarm latch: PV transfer (0 = No Latch, 1 = Latch)	uint8	03B5	949
Control.1.AlmSig.ClosedLoop	Process alarm signalling status: Closed loop break (0 = Not latched, 1 = Latched)	uint8	03B1	945
Control.1.AlmSig.Limitation	Indication alarm signalling status: Limitation (0 = Not latched, 1 = Latched)	uint8	03B3	947
Control.1.AlmSig.PVTransfer	Indication alarm signalling status: PV transfer (0 = Not latched, 1 = Latched)	uint8	03B2	946
Control.1.AlmStop.ClosedLoop	Process alarm stop: Closed loop break (0 = No Stop, 1 = Stop)	uint8	03BA	954
Control.1.AlmStop.Limitation	Indication alarm stop: Limitation	uint8	03BC	956
Control.1.AlmStop.PVTransfer	Indication alarm stop: PV transfer	uint8	03BB	955
Control.1.Diag.Output	Output of the controller	float32	03A9	937
Control.1.Diag.PAOP	Phase angle output for PA reduction in burst firing	float32	03AA	938
Control.1.Diag.Status	Status of the controller (0 = Main PV, 1 = Transfr, 4 = Limit 1, 5 = Limit 2, 6 = Limit 3)	uint8	03A8	936
Control.1.Limit.PV1	Threshold Limit PV1	float32	03A1	929
Control.1.Limit.PV2	Threshold Limit PV2	float32	03A2	930
Control.1.Limit.PV3	Threshold Limit PV3	float32	03A3	931
Control.1.Limit.SP1	Threshold limit setpoint 1	float32	03A4	932
Control.1.Limit.SP2	Threshold limit setpoint 2	float32	03A5	933
Control.1.Limit.SP3	Threshold limit setpoint 3	float32	03A6	934
Control.1.Limit.TI	Integral time of the limit loop	float32	03A7	935
Control.1.Main.PV	The main PV of the controller	float32	039C	924
Control.1.Main.SP	Main SP to control at	float32	039D	925
Control.1.Main.TI	Integral time of the main loop	float32	03A0	928
Control.1.Main.TransferPV	The transfer (proportional limit) PV	float32	039E	926
Control.1.Main.TransferSpan	The transfer (proportional limit) span	float32	039F	927
Control.1.Setup.EnLimit	Enable Threshold Limit (0 = No, 1 = Yes)	uint8	0396	918
Control.1.Setup.FFGain	Feedforward gain	float32	0399	921
Control.1.Setup.FFOffset	Feedforward offset	float32	039A	922
Control.1.Setup.FFType	Defines the type of Feed Forward to be used (0 = Off, 1 = Trim, 2 = FFOnly)	uint8	0398	920
Control.1.Setup.NominalPV	Nominal PV of this phase of power control	float32	0395	917
Control.1.Setup.Standby	Put controller into standby (0 = No, 1 = Yes)	uint8	0394	916
Control.1.Setup.TransferEn	Enable Transfer (Proportional limit) (0 = NO, 1 = Yes)	uint8	0397	919
	Control 2. See Control 1 for enumeration values			
Control.2.AlmAck.ClosedLoop	Process alarm ack: Closed loop break	uint8	03E9	1001
Control.2.AlmAck.Limitation	Indication alarm ack: Limitation	uint8	03EB	1003
Control.2.AlmAck.PVTransfer	Indication alarm ack: PV transfer	uint8	03EA	1002
Control.2.AlmDet.ClosedLoop	Process alarm detection status: Closed loop break	uint8	03E0	992
Control.2.AlmDet.Limitation	Indication alarm detection status: Limitation	uint8	03E2	994
Control.2.AlmDet.PVTransfer	Indication alarm detection status: PV transfer	uint8	03E1	993

8.4 PARAMETER TABLE (Cont.)

Parameter path	Description	Type	Hex	Dec
Control.2.AlmDis.ClosedLoop	Process alarm: Closed loop break	uint8	03DD	989
Control.2.AlmDis.Limitation	Indication alarm: Limitation	uint8	03DF	991
Control.2.AlmDis.PVTransfer	Indication alarm: PV transfer	uint8	03DE	990
Control.2.AlmLat.ClosedLoop	Process alarm latch: Closed loop break	uint8	03E6	998
Control.2.AlmLat.Limitation	Indication alarm latch: Limitation	uint8	03E8	1000
Control.2.AlmLat.PVTransfer	Indication alarm latch: PV transfer	uint8	03E7	999
Control.2.AlmSig.ClosedLoop	Process alarm signalling status: Closed loop break	uint8	03E3	995
Control.2.AlmSig.Limitation	Indication alarm signalling status: Limitation	uint8	03E5	997
Control.2.AlmSig.PVTransfer	Indication alarm signalling status: PV transfer	uint8	03E4	996
Control.2.AlmStop.ClosedLoop	Process alarm stop: Closed loop break	uint8	03EC	1004
Control.2.AlmStop.Limitation	Indication alarm stop: Limitation	uint8	03EE	1006
Control.2.AlmStop.PVTransfer	Indication alarm stop: PV transfer	uint8	03ED	1005
Control.2.Diag.Output	Output of the controller	float32	03DB	987
Control.2.Diag.PAOP	Phase angle output for PA reduction in burst firing	float32	03DC	988
Control.2.Diag.Status	Status of the controller	uint8	03DA	986
Control.2.Limit.PV1	Threshold Limit PV1	float32	03D3	979
Control.2.Limit.PV2	Threshold Limit PV2	float32	03D4	980
Control.2.Limit.PV3	Threshold Limit PV3	float32	03D5	981
Control.2.Limit.SP1	Threshold limit setpoint 1	float32	03D6	982
Control.2.Limit.SP2	Threshold limit setpoint 2	float32	03D7	983
Control.2.Limit.SP3	Threshold limit setpoint 3	float32	03D8	984
Control.2.Limit.TI	Integral time of the limit loop	float32	03D9	985
Control.2.Main.PV	The main PV of the controller	float32	03CE	974
Control.2.Main.SP	Main SP to control at	float32	03CF	975
Control.2.Main.TI	Integral time of the main loop	float32	03D2	978
Control.2.Main.TransferPV	The transfer (proportional limit) PV	float32	03D0	976
Control.2.Main.TransferSpan	The transfer (proportional limit) span	float32	03D1	977
Control.2.Setup.EnLimit	Enable Threshold Limit	uint8	03C8	968
Control.2.Setup.FFGain	Feedforward gain	float32	03CB	971
Control.2.Setup.FFOffset	Feedforward offset	float32	03CC	972
Control.2.Setup.FFType	Defines the type of Feed Forward to be used	uint8	03CA	970
Control.2.Setup.NominalPV	Nominal PV of this phase of power control	float32	03C7	967
Control.2.Setup.Standby	Put controller into standby	uint8	03C6	966
Control.2.Setup.TransferEn	Enable Transfer (Proportional limit)	uint8	03C9	969
	Control 3. See Control 1 for enumeration values			
Control.3.AlmAck.ClosedLoop	Process alarm ack: Closed loop break	uint8	041B	1051
Control.3.AlmAck.Limitation	Indication alarm ack: Limitation	uint8	041D	1053
Control.3.AlmAck.PVTransfer	Indication alarm ack: PV transfer	uint8	041C	1052
Control.3.AlmDet.ClosedLoop	Process alarm detection status: Closed loop break	uint8	0412	1042
Control.3.AlmDet.Limitation	Indication alarm detection status: Limitation	uint8	0414	1044
Control.3.AlmDet.PVTransfer	Indication alarm detection status: PV transfer	uint8	0413	1043
Control.3.AlmDis.ClosedLoop	Process alarm: Closed loop break	uint8	040F	1039
Control.3.AlmDis.Limitation	Indication alarm: Limitation	uint8	0411	1041
Control.3.AlmDis.PVTransfer	Indication alarm: PV transfer	uint8	0410	1040
Control.3.AlmLat.ClosedLoop	Process alarm latch: Closed loop break	uint8	0418	1048
Control.3.AlmLat.Limitation	Indication alarm latch: Limitation	uint8	041A	1050
Control.3.AlmLat.PVTransfer	Indication alarm latch: PV transfer	uint8	0419	1049
Control.3.AlmSig.ClosedLoop	Process alarm signalling status: Closed loop break	uint8	0415	1045
Control.3.AlmSig.Limitation	Indication alarm signalling status: Limitation	uint8	0417	1047
Control.3.AlmSig.PVTransfer	Indication alarm signalling status: PV transfer	uint8	0416	1046
Control.3.AlmStop.ClosedLoop	Process alarm stop: Closed loop break	uint8	041E	1054
Control.3.AlmStop.Limitation	Indication alarm stop: Limitation	uint8	0420	1056
Control.3.AlmStop.PVTransfer	Indication alarm stop: PV transfer	uint8	041F	1055
Control.3.Diag.Output	Output of the controller	float32	040D	1037
Control.3.Diag.PAOP	Phase angle output for PA reduction in burst firing	float32	040E	1038
Control.3.Diag.Status	Status of the controller	uint8	040C	1036
Control.3.Limit.PV1	Threshold Limit PV1	float32	0405	1029
Control.3.Limit.PV2	Threshold Limit PV2	float32	0406	1030
Control.3.Limit.PV3	Threshold Limit PV3	float32	0407	1031

8.4 PARAMETER TABLE (Cont.)

Parameter path	Description	Type	Hex	Dec
Control.3.Limit.SP1	Threshold limit setpoint 1	float32	0408	1032
Control.3.Limit.SP2	Threshold limit setpoint 2	float32	0409	1033
Control.3.Limit.SP3	Threshold limit setpoint 3	float32	040A	1034
Control.3.Limit.TI	Integral time of the limit loop	float32	040B	1035
Control.3.Main.PV	The main PV of the controller	float32	0400	1024
Control.3.Main.SP	Main SP to control at	float32	0401	1025
Control.3.Main.TI	Integral time of the main loop	float32	0404	1028
Control.3.Main.TransferPV	The transfer (proportional limit) PV	float32	0402	1026
Control.3.Main.TransferSpan	The transfer (proportional limit) span	float32	0403	1027
Control.3.Setup.EnLimit	Enable Threshold Limit	uint8	03FA	1018
Control.3.Setup.FFGain	Feedforward gain	float32	03FD	1021
Control.3.Setup.FFOffset	Feedforward offset	float32	03FE	1022
Control.3.Setup.FFType	Defines the type of Feed Forward to be used	uint8	03FC	1020
Control.3.Setup.NominalPV	Nominal PV of this phase of power control	float32	03F9	1017
Control.3.Setup.Standby	Put controller into standby	uint8	03F8	1016
Control.3.Setup.TransferEn	Enable Transfer (Proportional limit)	uint8	03FB	1019
	Control 4. See Control 1 for enumeration values			
Control.4.AlmAck.ClosedLoop	Process alarm ack: Closed loop break	uint8	044D	1101
Control.4.AlmAck.Limitation	Indication alarm ack: Limitation	uint8	044F	1103
Control.4.AlmAck.PVTransfer	Indication alarm ack: PV transfer	uint8	044E	1102
Control.4.AlmDet.ClosedLoop	Process alarm detection status: Closed loop break	uint8	0444	1092
Control.4.AlmDet.Limitation	Indication alarm detection status: Limitation	uint8	0446	1094
Control.4.AlmDet.PVTransfer	Indication alarm detection status: PV transfer	uint8	0445	1093
Control.4.AlmDis.ClosedLoop	Process alarm: Closed loop break	uint8	0441	1089
Control.4.AlmDis.Limitation	Indication alarm: Limitation	uint8	0443	1091
Control.4.AlmDis.PVTransfer	Indication alarm: PV transfer	uint8	0442	1090
Control.4.AlmLat.ClosedLoop	Process alarm latch: Closed loop break	uint8	044A	1098
Control.4.AlmLat.Limitation	Indication alarm latch: Limitation	uint8	044C	1100
Control.4.AlmLat.PVTransfer	Indication alarm latch: PV transfer	uint8	044B	1099
Control.4.AlmSig.ClosedLoop	Process alarm signalling status: Closed loop break	uint8	0447	1095
Control.4.AlmSig.Limitation	Indication alarm signalling status: Limitation	uint8	0449	1097
Control.4.AlmSig.PVTransfer	Indication alarm signalling status: PV transfer	uint8	0448	1096
Control.4.AlmStop.ClosedLoop	Process alarm stop: Closed loop break	uint8	0450	1104
Control.4.AlmStop.Limitation	Indication alarm stop: Limitation	uint8	0452	1106
Control.4.AlmStop.PVTransfer	Indication alarm stop: PV transfer	uint8	0451	1105
Control.4.Diag.Output	Output of the controller	float32	043F	1087
Control.4.Diag.PAOP	Phase angle output for PA reduction in burst firing	float32	0440	1088
Control.4.Diag.Status	Status of the controller	uint8	043E	1086
Control.4.Limit.PV1	Threshold Limit PV1	float32	0437	1079
Control.4.Limit.PV2	Threshold Limit PV2	float32	0438	1080
Control.4.Limit.PV3	Threshold Limit PV3	float32	0439	1081
Control.4.Limit.SP1	Threshold limit setpoint 1	float32	043A	1082
Control.4.Limit.SP2	Threshold limit setpoint 2	float32	043B	1083
Control.4.Limit.SP3	Threshold limit setpoint 3	float32	043C	1084
Control.4.Limit.TI	Integral time of the limit loop	float32	043D	1085
Control.4.Main.PV	The main PV of the controller	float32	0432	1074
Control.4.Main.SP	Main SP to control at	float32	0433	1075
Control.4.Main.TI	Integral time of the main loop	float32	0436	1078
Control.4.Main.TransferPV	The transfer (proportional limit) PV	float32	0434	1076
Control.4.Main.TransferSpan	The transfer (proportional limit) span	float32	0435	1077
Control.4.Setup.EnLimit	Enable Threshold Limit	uint8	042C	1068
Control.4.Setup.FFGain	Feedforward gain	float32	042F	1071
Control.4.Setup.FFOffset	Feedforward offset	float32	0430	1072
Control.4.Setup.FFType	Defines the type of Feed Forward to be used	uint8	042E	1070
Control.4.Setup.NominalPV	Nominal PV of this phase of power control	float32	042B	1067
Control.4.Setup.Standby	Put controller into standby	uint8	042A	1066
Control.4.Setup.TransferEn	Enable Transfer (Proportional limit)	uint8	042D	1069
Counter.1.ClearOverflow	Clear OverFlow Flag (0 = No, 1 = Yes)	bool	0A12	2578
Counter.1.Clock	Clock Input	bool	0A0E	2574

8.4 PARAMETER TABLE (Cont.)

Parameter path	Description	Type	Hex	Dec
Counter.1.Count	Count Value	int32	0A10	2576
Counter.1.Direction	Direction of Count (0 = Up, 1 = Down)	bool	0A0B	2571
Counter.1.Enable	Enable the Counter (0 = No, 1 = Yes)	bool	0A0A	2570
Counter.1.Overflow	Overflow Flag (0 = No, 1 = Yes)	bool	0A0D	2573
Counter.1.Reset	Counter Reset (0 = No, 1 = Yes)	bool	0A11	2577
Counter.1.RippleCarry	Ripple Carry Enable Output (0 = Off, 1 = On)	bool	0A0C	2572
Counter.1.Target	Counter Target	int32	0A0F	2575
Counter.2.ClearOverflow	Clear Overflow Flag (0 = No, 1 = Yes)	bool	0A25	2597
Counter.2.Clock	Clock Input	bool	0A21	2593
Counter.2.Count	Count Value	int32	0A23	2595
Counter.2.Direction	Direction of Count (0 = Up, 1 = Down)	bool	0A1E	2590
Counter.2.Enable	Enable the Counter (0 = No, 1 = Yes)	bool	0A1D	2589
Counter.2.Overflow	Overflow Flag (0 = No, 1 = Yes)	bool	0A20	2592
Counter.2.Reset	Counter Reset (0 = No, 1 = Yes)	bool	0A24	2596
Counter.2.RippleCarry	Ripple Carry Enable Output (0 = Off, 1 = On)	bool	0A1F	2591
Counter.2.Target	Counter Target	int32	0A22	2594
Counter.3.ClearOverflow	Clear Overflow Flag (0 = No, 1 = Yes)	bool	0A38	2616
Counter.3.Clock	Clock Input	bool	0A34	2612
Counter.3.Count	Count Value	int32	0A36	2614
Counter.3.Direction	Direction of Count (0 = Up, 1 = Down)	bool	0A31	2609
Counter.3.Enable	Enable the Counter (0 = No, 1 = Yes)	bool	0A30	2608
Counter.3.Overflow	Overflow Flag (0 = No, 1 = Yes)	bool	0A33	2611
Counter.3.Reset	Counter Reset (0 = No, 1 = Yes)	bool	0A37	2615
Counter.3.RippleCarry	Ripple Carry Enable Output (0 = Off, 1 = On)	bool	0A32	2610
Counter.3.Target	Counter Target	int32	0A35	2613
Counter.4.ClearOverflow	Clear Overflow Flag (0 = No, 1 = Yes)	bool	0A4B	2635
Counter.4.Clock	Clock Input	bool	0A47	2631
Counter.4.Count	Count Value	int32	0A49	2633
Counter.4.Direction	Direction of Count (0 = Up, 1 = Down)	bool	0A44	2628
Counter.4.Enable	Enable the Counter (0 = No, 1 = Yes)	bool	0A43	2627
Counter.4.Overflow	Overflow Flag (0 = No, 1 = Yes)	bool	0A46	2630
Counter.4.Reset	Counter Reset (0 = No, 1 = Yes)	bool	0A4A	2634
Counter.4.RippleCarry	Ripple Carry Enable Output (0 = Off, 1 = On)	bool	0A45	2629
Counter.4.Target	Counter Target	int32	0A48	2632
CustPage.1.CISP1	Parameter 1	uint32	07F8	2040
CustPage.1.CISP2	Parameter 2	uint32	07F9	2041
CustPage.1.CISP3	Parameter 3	uint32	07FA	2042
CustPage.1.CISP4	Parameter 4	uint32	07FB	2043
CustPage.1.Style1	Custom Line 1 Style	uint8	07FC	2044
CustPage.1.Style2	Custom Line 2 Style	uint8	07FD	2045
CustPage.1.Style3	Custom Line 3 Style	uint8	07FE	2046
CustPage.1.Style4	Custom Line 4 Style	uint8	07FF	2047
CustPage.1.UserText1	Custom Text 1	string	4000	16384
CustPage.1.UserText2	Custom Text 2	string	4005	16389
CustPage.1.UserText3	Custom Text 3	string	400A	16394
CustPage.1.UserText4	Custom Text 4	string	400F	16399
CustPage.2.CISP1	Parameter 1	uint32	080C	2060
CustPage.2.CISP2	Parameter 2	uint32	080D	2061
CustPage.2.CISP3	Parameter 3	uint32	080E	2062
CustPage.2.CISP4	Parameter 4	uint32	080F	2063
CustPage.2.Style1	Custom Line 1 Style	uint8	0810	2064
CustPage.2.Style2	Custom Line 2 Style	uint8	0811	2065
CustPage.2.Style3	Custom Line 3 Style	uint8	0812	2066
CustPage.2.Style4	Custom Line 4 Style	uint8	0813	2067
CustPage.2.UserText1	Custom Text 1	string	4014	16404
CustPage.2.UserText2	Custom Text 2	string	4019	16409
CustPage.2.UserText3	Custom Text 3	string	401E	16414

8.4 PARAMETER TABLE (Cont.)

Parameter path	Description	Type	Hex	Dec
CustPage.2.UserText4	Custom Text 4	string	4023	16419
CustPage.3.CISP1	Parameter 1	uint32	0820	2080
CustPage.3.CISP2	Parameter 2	uint32	0821	2081
CustPage.3.CISP3	Parameter 3	uint32	0822	2082
CustPage.3.CISP4	Parameter 4	uint32	0823	2083
CustPage.3.Style1	Custom Line 1 Style	uint8	0824	2084
CustPage.3.Style2	Custom Line 2 Style	uint8	0825	2085
CustPage.3.Style3	Custom Line 3 Style	uint8	0826	2086
CustPage.3.Style4	Custom Line 4 Style	uint8	0827	2087
CustPage.3.UserText1	Custom Text 1	string	4028	16424
CustPage.3.UserText2	Custom Text 2	string	402D	16429
CustPage.3.UserText3	Custom Text 3	string	4032	16434
CustPage.3.UserText4	Custom Text 4	string	4037	16439
CustPage.4.CISP1	Parameter 1	uint32	0834	2100
CustPage.4.CISP2	Parameter 2	uint32	0835	2101
CustPage.4.CISP3	Parameter 3	uint32	0836	2102
CustPage.4.CISP4	Parameter 4	uint32	0837	2103
CustPage.4.Style1	Custom Line 1 Style	uint8	0838	2104
CustPage.4.Style2	Custom Line 2 Style	uint8	0839	2105
CustPage.4.Style3	Custom Line 3 Style	uint8	083A	2106
CustPage.4.Style4	Custom Line 4 Style	uint8	083B	2107
CustPage.4.UserText1	Custom Text 1	string	403C	16444
CustPage.4.UserText2	Custom Text 2	string	4041	16449
CustPage.4.UserText3	Custom Text 3	string	4046	16454
CustPage.4.UserText4	Custom Text 4	string	404B	16459
Energy.1.AutoScaleUnits	Autoscale energy units (0 = No, 1 = Yes)	bool	0B0F	2831
Energy.1.Hold	Hold the output of the counter	bool	0B05	2821
Energy.1.Input	Input to totalise	float32	0B06	2822
Energy.1.prvTotEnergy	Internal value of the Energy in Watt-hours	float32	0B10	2832
Energy.1.prvUsrEnergy	Internal value of the Energy in Watt-hours	float32	0B11	2833
Energy.1.Pulse	Pulsed output	bool	0B09	2825
Energy.1.PulseLen	Length of the pulse in ms	uint16	0B0A	2826
Energy.1.PulseScale	Amount of energy per pulse (0 = Disabled, 1 = 1, 2 = 10, 3 = 100, 4 = 1k 5 = 10k, 6 = 100k, 7 = 1M)	uint8	0B0C	2828
Energy.1.Reset	Set the user counter back to zero	bool	0B07	2823
Energy.1.TotEnergy	The global energy	float32	0B08	2824
Energy.1.TotEnergyUnit	Total energy counter units multiplier. (0 = 1; 1 = 10, 2 = 100, 3 = 1k, 4 = 10k, 5 = 100k 6 = 1M. 7 = 10M, 8 = 100M, 9 = 1G)	uint8	0B0D	2829
Energy.1.Type	Type of energy counter (0 = Normal, 1 = Global)	bool	0B0E	2830
Energy.1.UsrEnergy	User resetable energy	float32	0B04	2820
Energy.1.UsrEnergyUnit	User energy units multiplier. (0 = 1; 1 = 10, 2 = 100, 3 = 1k, 4 = 10k, 5 = 100k 6 = 1M. 7 = 10M, 8 = 100M, 9 = 1G)	uint8	0B0B	2827
Energy.2.AutoScaleUnits	Autoscale the unit of the energy (0 = No, 1 = Yes)	bool	0B23	2851
Energy.2.Hold	Hold the output of the counter	bool	0B19	2841
Energy.2.Input	Input to totalise	float32	0B1A	2842
Energy.2.prvTotEnergy	Internal value of the Energy in Watt-hours	float32	0B24	2852
Energy.2.prvUsrEnergy	Internal value of the Energy in Watt-hours	float32	0B25	2853
Energy.2.Pulse	Pulsed output	bool	0B1D	2845
Energy.2.PulseLen	Length of the pulse in ms	uint16	0B1E	2846
Energy.2.PulseScale	Amount of energy per pulse (as 'Energy 1')	uint8	0B20	2848
Energy.2.Reset	Set the user counter back to zero	bool	0B1B	2843
Energy.2.TotEnergy	The global energy	float32	0B1C	2844
Energy.2.TotEnergyUnit	Total energy counter units (as 'Energy 1')	uint8	0B21	2849
Energy.2.Type	Type of energy counter (0 = Normal, 1 = Global)	bool	0B22	2850
Energy.2.UsrEnergy	User resetable energy	float32	0B18	2840

8.4 PARAMETER TABLE (Cont.)

Parameter path	Description	Type	Hex	Dec
Energy.2.UsrEnergyUnit	User energy units multiplier (as 'Energy 1')	uint8	0B1F	2847
Energy.3.AutoScaleUnits	Autoscale the unit of the energy (0 = No, 1 = Yes)	bool	0B37	2871
Energy.3.Hold	Hold the output of the counter	bool	0B2D	2861
Energy.3.Input	Input to totalize	float32	0B2E	2862
Energy.3.prvTotEnergy	Internal value of the Energy in Watt-hours	float32	0B38	2872
Energy.3.prvUsrEnergy	Internal value of the Energy in Watt-hours	float32	0B39	2873
Energy.3.Pulse	Pulsed output	bool	0B31	2865
Energy.3.PulseLen	Length of the pulse in ms	uint16	0B32	2866
Energy.3.PulseScale	Amount of energy per pulse (as 'Energy 1')	uint8	0B34	2868
Energy.3.Reset	Set the user counter back to zero	bool	0B2F	2863
Energy.3.TotEnergy	The global energy	float32	0B30	2864
Energy.3.TotEnergyUnit	Total energy counter units (as 'Energy 1')	uint8	0B35	2869
Energy.3.Type	Type of energy counter (0 = Normal, 1 = Global)	bool	0B36	2870
Energy.3.UsrEnergy	User resetable energy	float32	0B2C	2860
Energy.3.UsrEnergyUnit	User energy units multiplier (as 'Energy 1')	uint8	0B33	2867
Energy.4.AutoScaleUnits	Autoscale the unit of the energy (0 = No, 1 = Yes)	bool	0B4B	2891
Energy.4.Hold	Hold the output of the counter	bool	0B41	2881
Energy.4.Input	Input to totalize	float32	0B42	2882
Energy.4.prvTotEnergy	Internal value of the Energy in Watt-hours	float32	0B4C	2892
Energy.4.prvUsrEnergy	Internal value of the Energy in Watt-hours	float32	0B4D	2893
Energy.4.Pulse	Pulsed output	bool	0B45	2885
Energy.4.PulseLen	Length of the pulse in ms	uint16	0B46	2886
Energy.4.PulseScale	Amount of energy per pulse (as 'Energy 1')	uint8	0B48	2888
Energy.4.Reset	Set the user counter back to zero	bool	0B43	2883
Energy.4.TotEnergy	The global energy	float32	0B44	2884
Energy.4.TotEnergyUnit	Total energy counter units (as 'Energy 1')	uint8	0B49	2889
Energy.4.Type	Type of energy counter (0 = Normal, 1 = Global)	bool	0B4A	2890
Energy.4.UsrEnergy	User resetable energy	float32	0B40	2880
Energy.4.UsrEnergyUnit	User energy units multiplier (as 'Energy 1')	uint8	0B47	2887
Energy.5.AutoScaleUnits	Autoscale the unit of the energy (0 = No, 1 = Yes)	bool	0B5F	2911
Energy.5.Hold	Hold the output of the counter	bool	0B55	2901
Energy.5.Input	Input to totalize	float32	0B56	2902
Energy.5.prvTotEnergy	Internal value of the Energy in Watt-hours	float32	0B60	2912
Energy.5.prvUsrEnergy	Internal value of the Energy in Watt-hours	float32	0B61	2913
Energy.5.Pulse	Pulsed output	bool	0B59	2905
Energy.5.PulseLen	Length of the pulse in ms	uint16	0B5A	2906
Energy.5.PulseScale	Amount of energy per pulse (as 'Energy 1')	uint8	0B5C	2908
Energy.5.Reset	Set the user counter back to zero	bool	0B57	2903
Energy.5.TotEnergy	The global energy	float32	0B58	2904
Energy.5.TotEnergyUnit	Total energy counter units (as 'Energy 1')	uint8	0B5D	2909
Energy.5.Type	Type of energy counter (0 = Normal, 1 = Global)	bool	0B5E	2910
Energy.5.UsrEnergy	User resetable energy	float32	0B54	2900
Energy.5.UsrEnergyUnit	User energy units multiplier (as 'Energy 1')	uint8	0B5B	2907
EventLog.Event01ID	Event 1 identification	uint8	070F	1807
EventLog.Event01Type	Event 1 type	uint8	070E	1806
EventLog.Event02ID	Event 2 Identification	uint8	0711	1809
EventLog.Event02Type	Event 2 type	uint8	0710	1808
EventLog.Event03ID	Event 3 Identification	uint8	0713	1811
EventLog.Event03Type	Event 3 type	uint8	0712	1810
EventLog.Event04ID	Event 4 Identification	uint8	0715	1813
EventLog.Event04Type	Event 4 type	uint8	0714	1812
EventLog.Event05ID	Event 5 Identification	uint8	0717	1815
EventLog.Event05Type	Event 5 type	uint8	0716	1814
EventLog.Event06ID	Event 6 Identification	uint8	0719	1817
EventLog.Event06Type	Event 6 type	uint8	0718	1816
EventLog.Event07ID	Event 7 Identification	uint8	071B	1819
EventLog.Event07Type	Event 7 type	uint8	071A	1818
EventLog.Event08ID	Event 8 Identification	uint8	071D	1821

8.4 PARAMETER TABLE (Cont.)

Parameter path	Description	Type	Hex	Dec
EventLog.Event08Type	Event 8 type	uint8	071C	1820
EventLog.Event09ID	Event 9 Identification	uint8	071F	1823
EventLog.Event09Type	Event 9 type	uint8	071E	1822
EventLog.Event10ID	Event 10 Identification	uint8	0721	1825
EventLog.Event10Type	Event 10 type	uint8	0720	1824
EventLog.Event11ID	Event 11 Identification	uint8	0723	1827
EventLog.Event11Type	Event 11 type	uint8	0722	1826
EventLog.Event12ID	Event 12 Identification	uint8	0725	1829
EventLog.Event12Type	Event 12 type	uint8	0724	1828
EventLog.Event13ID	Event 13 Identification	uint8	0727	1831
EventLog.Event13Type	Event 13 type	uint8	0726	1830
EventLog.Event14ID	Event 14 Identification	uint8	0729	1833
EventLog.Event14Type	Event 14 type	uint8	0728	1832
EventLog.Event15ID	Event 15 Identification	uint8	072B	1835
EventLog.Event15Type	Event 15 type	uint8	072A	1834
EventLog.Event16ID	Event 16 Identification	uint8	072D	1837
EventLog.Event16Type	Event 16 type	uint8	072C	1836
EventLog.Event17ID	Event 17 Identification	uint8	072F	1839
EventLog.Event17Type	Event 17 type	uint8	072E	1838
EventLog.Event18ID	Event 18 Identification	uint8	0731	1841
EventLog.Event18Type	Event 18 type	uint8	0730	1840
EventLog.Event19ID	Event 19 Identification	uint8	0733	1843
EventLog.Event19Type	Event 19 type	uint8	0732	1842
EventLog.Event20ID	Event 20 Identification	uint8	0735	1845
EventLog.Event20Type	Event 20 type	uint8	0734	1844
EventLog.Event21ID	Event 21 Identification	uint8	0737	1847
EventLog.Event21Type	Event 21 type	uint8	0736	1846
EventLog.Event22ID	Event 22 Identification	uint8	0739	1849
EventLog.Event22Type	Event 22 type	uint8	0738	1848
EventLog.Event23ID	Event 23 Identification	uint8	073B	1851
EventLog.Event23Type	Event 23 type	uint8	073A	1850
EventLog.Event24ID	Event 24 Identification	uint8	073D	1853
EventLog.Event24Type	Event 24 type	uint8	073C	1852
EventLog.Event25ID	Event 25 Identification	uint8	073F	1855
EventLog.Event25Type	Event 25 type	uint8	073E	1854
EventLog.Event26ID	Event 26 Identification	uint8	0741	1857
EventLog.Event26Type	Event 26 type	uint8	0740	1856
EventLog.Event27ID	Event 27 Identification	uint8	0743	1859
EventLog.Event27Type	Event 27 type	uint8	0742	1858
EventLog.Event28ID	Event 28 Identification	uint8	0745	1861
EventLog.Event28Type	Event 28 type	uint8	0744	1860
EventLog.Event29ID	Event 29 Identification	uint8	0747	1863
EventLog.Event29Type	Event 29 type	uint8	0746	1862
EventLog.Event30ID	Event 30 Identification	uint8	0749	1865
EventLog.Event30Type	Event 30 type	uint8	0748	1864
EventLog.Event31ID	Event 31 Identification	uint8	074B	1867
EventLog.Event31Type	Event 31 type	uint8	074A	1866
EventLog.Event32ID	Event 32 Identification	uint8	074D	1869
EventLog.Event32Type	Event 32 type	uint8	074C	1868
EventLog.Event33ID	Event 33 Identification	uint8	074F	1871
EventLog.Event33Type	Event 33 type	uint8	074E	1870
EventLog.Event34ID	Event 34 Identification	uint8	0751	1873
EventLog.Event34Type	Event 34 type	uint8	0750	1872
EventLog.Event35ID	Event 35 Identification	uint8	0753	1875
EventLog.Event35Type	Event 35 type	uint8	0752	1874
EventLog.Event36ID	Event 36 Identification	uint8	0755	1877
EventLog.Event36Type	Event 36 type	uint8	0754	1876
EventLog.Event37ID	Event 37 Identification	uint8	0757	1879
EventLog.Event37Type	Event 37 type	uint8	0756	1878
EventLog.Event38ID	Event 38 Identification	uint8	0759	1881
EventLog.Event38Type	Event 38 type	uint8	0758	1880

Event ID	
0 = No entry	161 = InvPwrModRev
1 = Conf Exit	162 = HW Mismatch
2 = Conf Entry	163 = Pwr1 Ribbon
3 = Power down	164 = Pwr2 Ribbon
4 = Coldstart	165 = Pwr3 Ribbon
5 = QuickStart Exit	166 = Pwr4 Ribbon
6 = QuickStart Entry	167 = Pwr1EEProm
7 = Global Avk	168 = Pwr2EEProm
21 = Missing Mains	169 = Pwr3EEProm
22 = Thy Short cct.	170 = Pwr4EEProm
23 = Thy open cct.	171 = Log Fault
24 = Fuse Blown	172 = PWR1cal
25 = Over Temp	173 = PWR2cal
26 = Netw Dip	174 = PWR3cal
27 = Mains Freq	175 = PWR4cal
28 = PMod 24	176 = Watchdog
51 = TLF	177 = StdIOCal
52 = Chop Off	178 = Opt1IOCal
53 = PLF	179 = Opt2IOCal
54 = PLU	180 = Opt3IOCal
55 = Main V Fault	191 = Ph1Wdog
56 = Temp Pre-Alarm	192 = Ph1ComErr
57 = Input Brk	193 = Ph1ComTout
58 = Out Fault	194 = Ph2Wdog
59 = ClosedLp	195 = Ph2ComErr
81 = PrcValTh	196 = Ph2ComTout
82 = Limit Act	197 = Ph3Wdog
83 = Load Overl	198 = Ph3ComErr
84 = LMoverSch	199 = Ph3ComTout
111 = High	211 = Fuse Blown
112 = Low	212 = WdogFault
113 = Dev Band	213 = PwrRailFail
114 = Dev Low	214 = CommsTout
115 = Dev High	215 = Comms Err
131 = Fuse Config	241 = InvRamCsum
132 = Restart Fail	242 = DSPnoRSP
151 = InvPAdata	242 = DSPWdog
152 = Inv wires	

Event types	
1 = Instrument	33 = Ind Alm N3 InAct
2 = Sys Alm N1 Act	34 = Ind Alm N3 Ackd
3 = Sys Alm N1 InAct	35 = Ind Alm N4 Act
4 = Sys Alm N1 Ackd	36 = Ind Alm N4 InAct
5 = Sys Alm N2 Act	37 = Ind Alm N4 Ackd
6 = Sys Alm N2 InAct	38 = Prc Alm Ex1Act
7 = Sys Alm N2 Ackd	39 = Prc Alm Ex1InAct
8 = Sys Alm N3 Act	40 = Prc Alm Ex1Ackd
9 = Sys Alm N3 InAct	41 = Prc Alm Ex2Act
10 = Sys Alm N3 Ackd	42 = Prc Alm Ex2InAct
11 = Sys Alm N4 Act	43 = Prc Alm Ex2Ackd
12 = Sys Alm N4 InAct	44 = Prc Alm Ex3Act
13 = Sys Alm N4 Ackd	45 = Prc Alm Ex3InAct
14 = Prc Alm N1 Act	46 = Prc Alm Ex3Ackd
15 = Prc Alm N1 InAct	47 = Prc Alm Ex4Act
16 = Prc Alm N1 Ackd	48 = Prc Alm Ex4InAct
17 = Prc Alm N2 Act	49 = Prc Alm Ex4Ackd
18 = Prc Alm N2 InAct	50 = Err Fatal
19 = Prc Alm N2 Ackd	51 = Err Config
20 = Prc Alm N3 Act	52 = Err General
21 = Prc Alm N3 InAct	53 = Err Netw1
22 = Prc Alm N3 Ackd	54 = Err Netw2
23 = Prc Alm N4 Act	55 = Err Netw3
24 = Prc Alm N4 InAct	56 = Err Netw4
25 = Prc Alm N4 Ackd	57 = Err Pwr1
26 = Ind Alm N1 Act	58 = Err Pwr2
27 = Ind Alm N1 InAct	59 = Err Pwr3
28 = Ind Alm N1 Ackd	60 = Err Pwr4
29 = Ind Alm N2 Act	61 = Err DSP
30 = Ind Alm N2 InAct	62 = Err Restart
32 = Ind Alm N3 Act	63 = Err Standby

8.4 PARAMETER TABLE (Cont.)

Parameter path	Description	Type	Hex	Dec
EventLog.Event39ID	Event 39 Identification	uint8	075B	1883
EventLog.Event39Type	Event 39 type	uint8	075A	1882
EventLog.Event40ID	Event 40 Identification	uint8	075D	1885
EventLog.Event40Type	Event 40 type	uint8	075C	1884
EventLog.Status	Status word to indicate instrument errors via comms	uint8	075F	1887
Faultdet.AlarmStatus1	Alarm Status Word 1	uint16	06A8	1704
Faultdet.AlarmStatus2	Alarm Status Word 2	uint16	06A9	1705
Faultdet.AnyFuseAl	Any Fuse Blown alarm	uint8	06A3	1699
Faultdet.AnyNetwAl	Any Network Process Alarm	uint8	06A2	1698
Faultdet.GeneralAck	Global Acknowledge	uint8	069F	1695
Faultdet.GlobalDis	Global Disable all alarms	uint8	06A4	1700
Faultdet.StratStatus	Strategy Status Word Bit 0 = Network 1 not firing Bit 1 = Network 1 not synchronised Bit 2 = Network 2 not firing Bit 3 = Network 2 not synchronised Bit 4 = Network 3 not firing Bit 5 = Network 3 not synchronised Bit 6 = Network 4 not firing Bit 7 = Network 4 not synchronised Bit 8 = Strategy in Standby Mode Bit 9 = Strategy in Telemetry Mode Bits 10 to 15 Reserved.	uint16	06A6	1702
Faultdet.Watchdog	Indicates Watchdog Relay Status (1 = Active)	uint8	06A7	1703
FiringOP.1.DelayedTrigger	Delayed Triggering for transformer loads	uint8	04BA	1210
FiringOP.1.Enable	Enable of the firing output block	uint8	04BE	1214
FiringOP.1.In	Input of the firing output block	float32	04BB	1211
FiringOP.1.LoadCoupling	Load coupling configuration (0 = 3S, 1 = 3D, 2 = 4S, 3 = 6D)	uint8	04B4	1204
FiringOP.1.LoadType	Load type configuration (0 = Resistive, 1 = XFMR)	uint8	04B5	1205
FiringOP.1.Mode	Firing Mode indication (0 = IHC, 1 = Burst, 2 = PA, 3 = None)	uint8	04B6	1206
FiringOP.1.PaLimitIn	Phase angle input for PA reduction in burst firing	float32	04BC	1212
FiringOP.1.SafetyRamp	Safety ramp duration	float32	04B7	1207
FiringOP.1.SafetyRampStatus	Status of the safety ramp (0 = Ramping, 1 = Finished)	uint8	04BD	1213
FiringOP.1.SoftStart	Soft start duration	float32	04B8	1208
FiringOP.1.SoftStop	Soft stop duration (0 = Off, 1 = On)	float32	04B9	1209
FiringOP.2.DelayedTrigger	Delayed Triggering for transformer loads	uint8	04CF	1231
FiringOP.2.Enable	Enable of the firing output block	uint8	04D3	1235
FiringOP.2.In	Input of the firing output block	float32	04D0	1232
FiringOP.2.LoadCoupling	Load coupling configuration (0 = 3S, 1 = 3D, 2 = 4S, 3 = 6D)	uint8	04C9	1225
FiringOP.2.LoadType	Load type configuration (0 = Resistive, 1 = XFMR)	uint8	04CA	1226
FiringOP.2.Mode	Firing Mode indication (0 = IHC, 1 = Burst, 2 = PA, 3 = None)	uint8	04CB	1227
FiringOP.2.PaLimitIn	Phase angle input for PA reduction in burst firing	float32	04D1	1233
FiringOP.2.SafetyRamp	Safety ramp duration	float32	04CC	1228
FiringOP.2.SafetyRampStatus	Status of the safety ramp (0 = Ramping, 1 = Finished)	uint8	04D2	1234
FiringOP.2.SoftStart	Soft start duration	float32	04CD	1229
FiringOP.2.SoftStop	Soft stop duration (0 = Off, 1 = On)	float32	04CE	1230
FiringOP.3.DelayedTrigger	Delayed Triggering for transformer loads	uint8	04E4	1252
FiringOP.3.Enable	Enable of the firing output block	uint8	04E8	1256
FiringOP.3.In	Input of the firing output block	float32	04E5	1253
FiringOP.3.LoadCoupling	Load coupling configuration (0 = 3S, 1 = 3D, 2 = 4S, 3 = 6D)	uint8	04DE	1246
FiringOP.3.LoadType	Load type configuration (0 = Resistive, 1 = XFMR)	uint8	04DF	1247
FiringOP.3.Mode	Firing Mode indication (0 = IHC, 1 = Burst, 2 = PA, 3 = None)	uint8	04E0	1248

8.4 PARAMETER TABLE (Cont.)

Parameter path	Description	Type	Hex	Dec
FiringOP.3.PaLimitIn	Phase angle input for PA reduction in burst firing	float32	04E6	1254
FiringOP.3.SafetyRamp	Safety ramp duration	float32	04E1	1249
FiringOP.3.SafetyRampStatus	Status of the safety ramp (0 = Ramping, 1 = Finished)	uint8	04E7	1255
FiringOP.3.SoftStart	Soft start duration	float32	04E2	1250
FiringOP.3.SoftStop	Soft stop duration (0 = Off, 1 = On)	float32	04E3	1251
FiringOP.4.DelayedTrigger	Delayed Triggering for transformer loads	uint8	04F9	1273
FiringOP.4.Enable	Enable of the firing output block	uint8	04FD	1277
FiringOP.4.In	Input of the firing output block	float32	04FA	1274
FiringOP.4.LoadCoupling	Load coupling configuration (0 = 3S, 1 = 3D, 2 = 4S, 3 = 6D)	uint8	04F3	1267
FiringOP.4.LoadType	Load type configuration (0 = Resistive, 1 = XFMR)	uint8	04F4	1268
FiringOP.4.Mode	Firing Mode indication. (0 = IHC, 1 = Burst, 2 = PA, 3 = None)	uint8	04F5	1269
FiringOP.4.PaLimitIn	Phase angle input for PA reduction in burst firing	float32	04FB	1275
FiringOP.4.SafetyRamp	Safety ramp duration	float32	04F6	1270
FiringOP.4.SafetyRampStatus	Status of the safety ramp (0 = Ramping, 1 = Finished)	uint8	04FC	1276
FiringOP.4.SoftStart	Soft start duration	float32	04F7	1271
FiringOP.4.SoftStop	Soft stop duration (0 = Off, 1 = On)	float32	04F8	1272
Instrument.Configuration.IOModules	Number of Option IO Modules fitted	uint8	08A1	2209
Instrument.Configuration.PwrModType	Type of module. (0 = None, 1 = External. 2 = Internal 3 = MC Air cooled; 4 = MC Water cooled)	uint8	08B4	2228
Instrument.Configuration.LoadCoupling	Load coupling configuration (0 = 3S, 1 = 3D, 2 = 4S, 3 = 6D)	uint8	089A	2202
Instrument.Configuration. LoadCoupling2ndNetwork	Load 2 coupling configuration (as Load Coupling)	uint8	08A2	2210
Instrument.Configuration.LoadMFitted	Load Management Card Fitted (0 = No, 1 = Yes)	bool	08A4	2212
Instrument.Configuration.NetType	The type of network (0 = 3Ph, 1 = 1Ph, 2 = 2Ph)	uint8	0897	2199
Instrument.Configuration.PowerModules	Number of power modules fitted	uint8	0896	2198
Instrument.Configuration.PwrMod1Rev	Power Module 1 Revision (0 = invalid)	uint8	089C	2204
Instrument.Configuration.PwrMod2Rev	Power Module 2 Revision (0 = invalid)	uint8	089D	2205
Instrument.Configuration.PwrMod3Rev	Power Module 3 Revision (0 = invalid)	uint8	089E	2206
Instrument.Configuration.PwrMod4Rev	Power Module 4 Revision (0 = invalid)	uint8	089F	2207
Instrument.Configuration.RemotePV	Remote PV	float32	08A3	2211
Instrument.Configuration.TimerRes	Sets resolution of time parameters (0 = 0.1sec, 1 = 0.1 min)	uint8	08A0	2208
Instrument.Display.Language	Selected Language (1 = Eng, 2 = Fra, 4 = Ger, 8 = Ita, 16 = Spa)	uint8	0879	2169
Instrument.Display.SerialNo	Serial Number	int32	087A	2170
Instrument.ID	Instrument Identifier (E190h)	int16	007A	122
Instrument.Mode	Instrument Mode (0 = Operator mode, 1 = Standby, 2 = Config)	uint8	00C7	199
IO.AnalogIP.1.Main.MeasVal	Measured value	float32	05D3	1491
IO.AnalogIP.1.Main.PV	Process variable	float32	05D4	1492
IO.AnalogIP.1.Main.RangeHigh	High input range for scaling to process units	float32	05D1	1489
IO.AnalogIP.1.Main.RangeLow	Low input range for scaling to process units	float32	05D2	1490
IO.AnalogIP.1.Main.Type	Specify the input type 0 = 0 to 10V 1 = 1 to 5V 2 = 2 to 10V 3 = 0 to 5V 4 = 0 to 20mA 5 = 4 to 20mA.	uint8	05D0	1488
IO.AnalogIP.2.Main.MeasVal	Measured value	float32	05E2	1506
IO.AnalogIP.2.Main.PV	Process variable	float32	05E3	1507
IO.AnalogIP.2.Main.RangeHigh	High input range for scaling to process units	float32	05E0	1504
IO.AnalogIP.2.Main.RangeLow	Low input range for scaling to process units	float32	05E1	1505
IO.AnalogIP.2.Main.Type	Specify the input type (as IP1 above)	uint8	05DF	1503
IO.AnalogIP.3.Main.MeasVal	Measured value	float32	05F1	1521
IO.AnalogIP.3.Main.PV	Process variable	float32	05F2	1522
IO.AnalogIP.3.Main.RangeHigh	High input range for scaling to process units	float32	05EF	1519
IO.AnalogIP.3.Main.RangeLow	Low input range for scaling to process units	float32	05F0	1520
IO.AnalogIP.3.Main.Type	Specify the input type (as IP1 above)	uint8	05EE	1518

8.4 PARAMETER TABLE (Cont.)

Parameter path	Description	Type	Hex	Dec
IO.AnalogIP.4.Main.MeasVal	Measured value	float32	0600	1536
IO.AnalogIP.4.Main.PV	Process variable	float32	0601	1537
IO.AnalogIP.4.Main.RangeHigh	High input range for scaling to process units	float32	05FE	1534
IO.AnalogIP.4.Main.RangeLow	Low input range for scaling to process units	float32	05FF	1535
IO.AnalogIP.4.Main.Type	Specify the input type (as IP1 above)	uint8	05FD	1533
IO.AnalogIP.5.Main.MeasVal	Measured value	float32	060F	1551
IO.AnalogIP.5.Main.PV	Process variable	float32	0610	1552
IO.AnalogIP.5.Main.RangeHigh	High input range for scaling to process units	float32	060D	1549
IO.AnalogIP.5.Main.RangeLow	Low input range for scaling to process units	float32	060E	1550
IO.AnalogIP.5.Main.Type	Specify the input type (as IP1 above)	uint8	060C	1548
IO.AnalogOP.1.AlmAck.OutputFault	Process alarm acknowledge: Output Fault (0 = NoAck, 1 = Ack)	uint8	0624	1572
IO.AnalogOP.1.AlmDet.OutputFault	Process alarm detection status: Output Fault (0 = Inactive; 1 = Active)	uint8	0621	1569
IO.AnalogOP.1.AlmDis.OutputFault	Process alarm: Output Fault (0 = Enable, 1 = Disable)	uint8	0620	1568
IO.AnalogOP.1.AlmLat.OutputFault	Process alarm latch request: Output Fault (0 = NoLatch, 1 = Latch)	uint8	0623	1571
IO.AnalogOP.1.AlmSig.OutputFault	Process alarm signalling status: Output Fault (0 = Not Latched, 1 = Latched)	uint8	0622	1570
IO.AnalogOP.1.AlmStop.OutputFault	Process alarm stop request: Output Fault (0 = No stop, 1 = Stop)	uint8	0625	1573
IO.AnalogOP.1.Main.MeasVal	Measured value	float32	061F	1567
IO.AnalogOP.1.Main.PV	Process variable	float32	061E	1566
IO.AnalogOP.1.Main.RangeHigh	High input range for scaling from process units	float32	061C	1564
IO.AnalogOP.1.Main.RangeLow	Low input range for scaling from process units	float32	061D	1565
IO.AnalogOP.1.Main.Type	Specify the output type 0 = 0 to 10V 1 = 1 to 5 V 2 = 2 to 10V, 3 = 0 to 5V 4 = 0 to 20mA 5 = 4 to 20mA	uint8	061B	1563
IO.AnalogOP.2.AlmAck.OutputFault	Process alarm acknowledge: Output Fault (as OP.1)	uint8	0639	1593
IO.AnalogOP.2.AlmDet.OutputFault	Process alarm detection status: Output Fault (as OP.1)	uint8	0636	1590
IO.AnalogOP.2.AlmDis.OutputFault	Process alarm: Output Fault (as OP.1)	uint8	0635	1589
IO.AnalogOP.2.AlmLat.OutputFault	Process alarm latch request: Output Fault (as OP.1)	uint8	0638	1592
IO.AnalogOP.2.AlmSig.OutputFault	Process alarm signalling status: Output Fault (as OP.1)	uint8	0637	1591
IO.AnalogOP.2.AlmStop.OutputFault	Process alarm stop request: Output Fault (as OP.1)	uint8	063A	1594
IO.AnalogOP.2.Main.MeasVal	Measured value	float32	0634	1588
IO.AnalogOP.2.Main.PV	Process variable	float32	0633	1587
IO.AnalogOP.2.Main.RangeHigh	High input range for scaling from process units	float32	0631	1585
IO.AnalogOP.2.Main.RangeLow	Low input range for scaling from process units	float32	0632	1586
IO.AnalogOP.2.Main.Type	Specify the output type (as OP.1)	uint8	0630	1584
IO.AnalogOP.3.AlmAck.OutputFault	Process alarm acknowledge: Output Fault (as OP.1)	uint8	064E	1614
IO.AnalogOP.3.AlmDet.OutputFault	Process alarm detection status: Output Fault (as OP.1)	uint8	064B	1611
IO.AnalogOP.3.AlmDis.OutputFault	Process alarm: Output Fault (as OP.1)	uint8	064A	1610
IO.AnalogOP.3.AlmLat.OutputFault	Process alarm latch request: Output Fault (as OP.1)	uint8	064D	1613
IO.AnalogOP.3.AlmSig.OutputFault	Process alarm signalling status: Output Fault (as OP.1)	uint8	064C	1612
IO.AnalogOP.3.AlmStop.OutputFault	Process alarm stop request: Output Fault (as OP.1)	uint8	064F	1615
IO.AnalogOP.3.Main.MeasVal	Measured value	float32	0649	1609
IO.AnalogOP.3.Main.PV	Process variable	float32	0648	1608
IO.AnalogOP.3.Main.RangeHigh	High input range for scaling from process units	float32	0646	1606
IO.AnalogOP.3.Main.RangeLow	Low input range for scaling from process units	float32	0647	1607
IO.AnalogOP.3.Main.Type	Specify the output type (as OP.1)	uint8	0645	1605
IO.AnalogOP.4.AlmAck.OutputFault	Process alarm acknowledge: Output Fault (as OP.1)	uint8	0663	1635
IO.AnalogOP.4.AlmDet.OutputFault	Process alarm detection status: Output Fault (as OP.1)	uint8	0660	1632
IO.AnalogOP.4.AlmDis.OutputFault	Process alarm: Output Fault (as OP.1)	uint8	065F	1631
IO.AnalogOP.4.AlmLat.OutputFault	Process alarm latch request: Output Fault (as OP.1)	uint8	0662	1634
IO.AnalogOP.4.AlmSig.OutputFault	Process alarm signalling status: Output Fault (as OP.1)	uint8	0661	1633
IO.AnalogOP.4.AlmStop.OutputFault	Process alarm stop request: Output Fault (as OP.1)	uint8	0664	1636

8.4 PARAMETER TABLE (Cont.)

Parameter path	Description	Type	Hex	Dec
IO.AnalogOP.4.Main.MeasVal	Measured value	float32	065E	1630
IO.AnalogOP.4.Main.PV	Process variable	float32	065D	1629
IO.AnalogOP.4.Main.RangeHigh	High input range for scaling from process units	float32	065B	1627
IO.AnalogOP.4.Main.RangeLow	Low input range for scaling from process units	float32	065C	1628
IO.AnalogOP.4.Main.Type	Specify the output type (as OP.1)	uint8	065A	1626
IO.Digital.1.Invert	Invert the sense of the digital IO (0 = No; 1 = Invert)	bool	0559	1369
IO.Digital.1.MeasVal	Measured value (for outputs, 1 = output high)	bool	055A	1370
IO.Digital.1.PV	Process variable	bool	055B	1371
IO.Digital.1.Type	Specify the digital IO type 0 = Logic input; 1 = Contact input; 2 = Logic output.	uint8	0558	1368
IO.Digital.2.Invert	Invert the sense of the digital IO (0 = No; 1 = Invert)	bool	0568	1384
IO.Digital.2.MeasVal	Measured value (for outputs, 1 = output high)	bool	0569	1385
IO.Digital.2.PV	Process variable	bool	056A	1386
IO.Digital.2.Type	As IO.Digital.1.Type	uint8	0567	1383
IO.Digital.3.Invert	Invert the sense of the digital IO (0 = No; 1 = Invert)	bool	0577	1399
IO.Digital.3.MeasVal	Measured value (for outputs, 1 = output high)	bool	0578	1400
IO.Digital.3.PV	Process variable	bool	0579	1401
IO.Digital.3.Type	As IO.Digital.1.Type	uint8	0576	1398
IO.Digital.4.Invert	Invert the sense of the digital IO (0 = No; 1 = Invert)	bool	0586	1414
IO.Digital.4.MeasVal	Measured value (for outputs, 1 = output high)	bool	0587	1415
IO.Digital.4.PV	Process variable	bool	0588	1416
IO.Digital.4.Type	As IO.Digital.1.Type	uint8	0585	1413
IO.Digital.5.Invert	Invert the sense of the digital IO (0 = No; 1 = Invert)	bool	0595	1429
IO.Digital.5.MeasVal	Measured value (for outputs, 1 = output high)	bool	0596	1430
IO.Digital.5.PV	Process variable	bool	0597	1431
IO.Digital.5.Type	As IO.Digital.1.Type	uint8	0594	1428
IO.Digital.6.Invert	Invert the sense of the digital IO (0 = No; 1 = Invert)	bool	05A4	1444
IO.Digital.6.MeasVal	Measured value (for outputs, 1 = output high)	bool	05A5	1445
IO.Digital.6.PV	Process variable	bool	05A6	1446
IO.Digital.6.Type	As IO.Digital.1.Type	uint8	05A3	1443
IO.Digital.7.Invert	Invert the sense of the digital IO (0 = No; 1 = Invert)	bool	05B3	1459
IO.Digital.7.MeasVal	Measured value (for outputs, 1 = output high)	bool	05B4	1460
IO.Digital.7.PV	Process variable	bool	05B5	1461
IO.Digital.7.Type	As IO.Digital.1.Type	uint8	05B2	1458
IO.Digital.8.Invert	Invert the sense of the digital IO (0 = No; 1 = Invert)	bool	05C2	1474
IO.Digital.8.MeasVal	Measured value	bool	05C3	1475
IO.Digital.8.PV	Process variable	bool	05C4	1476
IO.Digital.8.Type	As IO.Digital.1.Type	uint8	05C1	1473
IO.Relay.1.MeasVal	Measured value	bool	0670	1648
IO.Relay.1.PV	Process Variable	bool	066F	1647
IO.Relay.2.MeasVal	Measured value	bool	067C	1660
IO.Relay.2.PV	Process Variable	bool	067B	1659
IO.Relay.3.MeasVal	Measured value	bool	0688	1672
IO.Relay.3.PV	Process Variable	bool	0687	1671
IO.Relay.4.MeasVal	Measured value	bool	0694	1684
IO.Relay.4.PV	Process Variable	bool	0693	1683
IPMonitor.1.AlarmDays	Alarm time (in days) above threshold	uint8	0A5F	2655
IPMonitor.1.AlarmTime	Alarm time above threshold	time32	0A5D	2653
IPMonitor.1.DaysAbove	Days Above Threshold	uint8	0A5E	2654
IPMonitor.1.In	Input	float32	0A57	2647
IPMonitor.1.InStatus	Input Status (0 = Good, 1 = Bad)	bool	0A60	2656
IPMonitor.1.Max	Maximum value	float32	0A59	2649

8.4 PARAMETER TABLE (Cont.)

Parameter path	Description	Type	Hex	Dec
IPMonitor.1.Min	Minimum value	float32	0A5A	2650
IPMonitor.1.Out	Timer Alarm Output (0 = Off, 1 = On)	bool	0A5C	2652
IPMonitor.1.Reset	Reset All Monitor Functions (0 = No, 1 = Yes)	bool	0A58	2648
IPMonitor.1.Threshold	Timer Threshold Value	float32	0A56	2646
IPMonitor.1.TimeAbove	Time in Hours Above Threshold	time32	0A5B	2651
IPMonitor.2.AlarmDays	Alarm time (in days) above threshold	uint8	0A75	2677
IPMonitor.2.AlarmTime	Alarm time above threshold	time32	0A73	2675
IPMonitor.2.DaysAbove	Days Above Threshold	uint8	0A74	2676
IPMonitor.2.In	Input	float32	0A6D	2669
IPMonitor.2.InStatus	Input Status (0 = Good, 1 = Bad)	bool	0A76	2678
IPMonitor.2.Max	Maximum value	float32	0A6F	2671
IPMonitor.2.Min	Minimum value	float32	0A70	2672
IPMonitor.2.Out	Timer Alarm Output (0 = Off, 1 = On)	bool	0A72	2674
IPMonitor.2.Reset	Reset All Monitor Functions (0 = No, 1 = Yes)	bool	0A6E	2670
IPMonitor.2.Threshold	Timer Threshold Value	float32	0A6C	2668
IPMonitor.2.TimeAbove	Time in Hours Above Threshold	time32	0A71	2673
IPMonitor.3.AlarmDays	Alarm time (in days) above threshold	uint8	0A8B	2699
IPMonitor.3.AlarmTime	Alarm time above threshold	time32	0A89	2697
IPMonitor.3.DaysAbove	Days Above Threshold	uint8	0A8A	2698
IPMonitor.3.In	Input	float32	0A83	2691
IPMonitor.3.InStatus	Input Status (0 = Good, 1 = Bad)	bool	0A8C	2700
IPMonitor.3.Max	Maximum value	float32	0A85	2693
IPMonitor.3.Min	Minimum value	float32	0A86	2694
IPMonitor.3.Out	Timer Alarm Output (0 = Off, 1 = On)	bool	0A88	2696
IPMonitor.3.Reset	Reset All Monitor Functions (0 = No, 1 = Yes)	bool	0A84	2692
IPMonitor.3.Threshold	Timer Threshold Value	float32	0A82	2690
IPMonitor.3.TimeAbove	Time in Hours Above Threshold	time32	0A87	2695
IPMonitor.4.AlarmDays	Alarm time (in days) above threshold	uint8	0AA1	2721
IPMonitor.4.AlarmTime	Alarm time above threshold	time32	0A9F	2719
IPMonitor.4.DaysAbove	Days Above Threshold	uint8	0AA0	2720
IPMonitor.4.In	Input	float32	0A99	2713
IPMonitor.4.InStatus	Input Status (0 = Good, 1 = Bad)	bool	0AA2	2722
IPMonitor.4.Max	Maximum value	float32	0A9B	2715
IPMonitor.4.Min	Minimum value	float32	0A9C	2716
IPMonitor.4.Out	Timer Alarm Output (0 = No, 1 = Yes)	bool	0A9E	2718
IPMonitor.4.Reset	Reset All Monitor Functions (0 = No, 1 = Yes)	bool	0A9A	2714
IPMonitor.4.Threshold	Timer Threshold Value	float32	0A98	2712
IPMonitor.4.TimeAbove	Time in Hours Above Threshold	time32	0A9D	2717
Lgc2.1.FallbackType	Fallback Condition (False good, False bad, True Good, True Bad)	uint8	0AB7	2743
Lgc2.1.Hysteresis	Hysteresis	float32	0ABB	2747
Lgc2.1.In1	Input Value 1	float32	0AB5	2741
Lgc2.1.In2	Input Value 2	float32	0AB6	2742
Lgc2.1.Invert	Sense of Input Value	uint8	0AB8	2744
Lgc2.1.Oper	Logic Operation (If True; Output = 1 (on)) 0 = Off 1 = AND 2 = OR 3 = XOR 4 = LATCH 5 = (lp1 = lp2?) 6 = (lp1 ≠ lp2?) 7 = (lp1 > lp2?), 8 = (lp1 < lp2?) 9 = (lp1 ≥ lp2?) 10 = (lp1 ≤ lp2?)	uint8	0AB4	2740
Lgc2.1.Out	The Result (0 = Off, 1 = On)	bool	0AB9	2745
Lgc2.1.Status	Output Status (0 = Good, 1 = Bad)	bool	0ABA	2746
Lgc2.2.FallbackType	Fallback Condition (as Lgc2.1)	uint8	0AC1	2753
Lgc2.2.Hysteresis	Hysteresis	float32	0AC5	2757
Lgc2.2.In1	Input Value 1	float32	0ABF	2751
Lgc2.2.In2	Input Value 2	float32	0AC0	2752
Lgc2.2.Invert	Sense of Input Value	uint8	0AC2	2754
Lgc2.2.Oper	Logic Operation (as Lgc2.1)	uint8	0ABE	2750
Lgc2.2.Out	The Result (0 = Off, 1 = On)	bool	0AC3	2755
Lgc2.2.Status	Output Status (0 = Good, 1 = Bad)	bool	0AC4	2756

8.4 PARAMETER TABLE (Cont.)

Parameter path	Description	Type	Hex	Dec
Lgc2.3.FallbackType	Fallback Condition (as Lgc2.1)	uint8	0ACB	2763
Lgc2.3.Hysteresis	Hysteresis	float32	0ACF	2767
Lgc2.3.In1	Input Value 1	float32	0AC9	2761
Lgc2.3.In2	Input Value 2	float32	0ACA	2762
Lgc2.3.Invert	Sense of Input Value	uint8	0ACC	2764
Lgc2.3.Oper	Logic Operation (as Lgc2.1)	uint8	0AC8	2760
Lgc2.3.Out	The Result (0 = Off, 1 = On)	bool	0ACD	2765
Lgc2.3.Status	Output Status (0 = Good, 1 = Bad)	bool	0ACE	2766
Lgc2.4.FallbackType	Fallback Condition (as Lgc2.1)	uint8	0AD5	2773
Lgc2.4.Hysteresis	Hysteresis	float32	0AD9	2777
Lgc2.4.In1	Input Value 1	float32	0AD3	2771
Lgc2.4.In2	Input Value 2	float32	0AD4	2772
Lgc2.4.Invert	Sense of Input Value	uint8	0AD6	2774
Lgc2.4.Oper	Logic Operation (as Lgc2.1)	uint8	0AD2	2770
Lgc2.4.Out	The Result (0 = Off, 1 = On)	bool	0AD7	2775
Lgc2.4.Status	Output Status (0 = Good, 1 = Bad)	bool	0AD8	2776
Lgc8.1.In1	Input 1 Value (0 = Off, 1 = On)	bool	09B1	2481
Lgc8.1.In2	Input 2 Value (0 = Off, 1 = On)	bool	09B2	2482
Lgc8.1.In3	Input 3 Value (0 = Off, 1 = On)	bool	09B3	2483
Lgc8.1.In4	Input 4 Value (0 = Off, 1 = On)	bool	09B4	2484
Lgc8.1.In5	Input 5 Value (0 = Off, 1 = On)	bool	09B5	2485
Lgc8.1.In6	Input 6 Value (0 = Off, 1 = On)	bool	09B6	2486
Lgc8.1.In7	Input 7 Value (0 = Off, 1 = On)	bool	09B7	2487
Lgc8.1.In8	Input 8 Value (0 = Off, 1 = On)	bool	09B8	2488
Lgc8.1.InInvert	Invert Selected Inputs	uint8	09AF	2479
Lgc8.1.NumIn	Number of Inputs	uint8	09B0	2480
Lgc8.1.Oper	Operation (0 = Off, 1 = AND, 2 = OR, 3 = XOR)	uint8	09AE	2478
Lgc8.1.Out	Output Value	bool	09B9	2489
Lgc8.1.OutInvert	Invert the Output (0 = No, 1 = Yes)	bool	09BA	2490
Lgc8.2.In1	Input 1 Value (0 = Off, 1 = On)	bool	09C8	2504
Lgc8.2.In2	Input 2 Value (0 = Off, 1 = On)	bool	09C9	2505
Lgc8.2.In3	Input 3 Value (0 = Off, 1 = On)	bool	09CA	2506
Lgc8.2.In4	Input 4 Value (0 = Off, 1 = On)	bool	09CB	2507
Lgc8.2.In5	Input 5 Value (0 = Off, 1 = On)	bool	09CC	2508
Lgc8.2.In6	Input 6 Value (0 = Off, 1 = On)	bool	09CD	2509
Lgc8.2.In7	Input 7 Value (0 = Off, 1 = On)	bool	09CE	2510
Lgc8.2.In8	Input 8 Value	bool	09CF	2511
Lgc8.2.InInvert	Invert Selected Inputs	uint8	09C6	2502
Lgc8.2.NumIn	Number of Inputs	uint8	09C7	2503
Lgc8.2.Oper	Operation (0 = Off, 1 = AND, 2 = OR, 3 = XOR)	uint8	09C5	2501
Lgc8.2.Out	Output Value	bool	09D0	2512
Lgc8.2.OutInvert	Invert the Output (0 = No, 1 = Yes)	bool	09D1	2513
Lgc8.3.In1	Input 1 Value (0 = Off, 1 = On)	bool	09DF	2527
Lgc8.3.In2	Input 2 Value (0 = Off, 1 = On)	bool	09E0	2528
Lgc8.3.In3	Input 3 Value (0 = Off, 1 = On)	bool	09E1	2529
Lgc8.3.In4	Input 4 Value (0 = Off, 1 = On)	bool	09E2	2530
Lgc8.3.In5	Input 5 Value (0 = Off, 1 = On)	bool	09E3	2531
Lgc8.3.In6	Input 6 Value (0 = Off, 1 = On)	bool	09E4	2532
Lgc8.3.In7	Input 7 Value (0 = Off, 1 = On)	bool	09E5	2533
Lgc8.3.In8	Input 8 Value (0 = Off, 1 = On)	bool	09E6	2534
Lgc8.3.InInvert	Invert Selected Inputs	uint8	09DD	2525
Lgc8.3.NumIn	Number of Inputs	uint8	09DE	2526
Lgc8.3.Oper	Operation (0 = Off, 1 = AND, 2 = OR, 3 = XOR)	uint8	09DC	2524
Lgc8.3.Out	Output Value	bool	09E7	2535
Lgc8.3.OutInvert	Invert the Output (0 = No, 1 = Yes)	bool	09E8	2536
Lgc8.4.In1	Input 1 Value (0 = Off, 1 = On)	bool	09F6	2550
Lgc8.4.In2	Input 2 Value (0 = Off, 1 = On)	bool	09F7	2551

8.4 PARAMETER TABLE (Cont.)

Parameter path	Description	Type	Hex	Dec
Lgc8.4.In3	Input 3 Value (0 = Off, 1 = On)	bool	09F8	2552
Lgc8.4.In4	Input 4 Value (0 = Off, 1 = On)	bool	09F9	2553
Lgc8.4.In5	Input 5 Value (0 = Off, 1 = On)	bool	09FA	2554
Lgc8.4.In6	Input 6 Value (0 = Off, 1 = On)	bool	09FB	2555
Lgc8.4.In7	Input 7 Value (0 = Off, 1 = On)	bool	09FC	2556
Lgc8.4.In8	Input 8 Value (0 = Off, 1 = On)	bool	09FD	2557
Lgc8.4.InInvert	Invert Selected Inputs	uint8	09F4	2548
Lgc8.4.NumIn	Number of Inputs	uint8	09F5	2549
Lgc8.4.Oper	Operation (0 = Off, 1 = AND, 2 = OR, 3 = XOR)	uint8	09F3	2547
Lgc8.4.Out	Output Value	bool	09FE	2558
Lgc8.4.OutInvert	Invert the Output (0 = No, 1 = Yes)	bool	09FF	2559
LTC.AlmAck.Fuse	System alarm ack: Fuse blown	uint8	0AF2	2802
LTC.AlmAck.Temp	System alarm ack: Over Temp	uint8	0AF3	2803
LTC.AlmDet.Fuse	System alarm detection status: Fuse Blown	uint8	0AEC	2796
LTC.AlmDet.Temp	System alarm detection status: Over Temp	uint8	0AED	2797
LTC.AlmDis.Fuse	System alarm Disable: External Fuse blown	uint8	0AEA	2794
LTC.AlmDis.Temp	System alarm Disable: External Over Temp	uint8	0AEB	2795
LTC.AlmLat.Fuse	System alarm latch: External Fuse Blown	uint8	0AF0	2800
LTC.AlmLat.Temp	System alarm latch: External Over Temp	uint8	0AF1	2801
LTC.AlmSig.Fuse	System alarm signalling status: external Fuse Blown	uint8	0AEE	2798
LTC.AlmSig.Temp	System alarm signalling status: external Over Temp	uint8	0AEF	2799
LTC.AlmStop.Fuse	System alarm stop: Fuse Blown	uint8	0AF4	2804
LTC.AlmStop.Temp	System alarm stop: Over Temp	uint8	0AF5	2805
LTC.MainPrm.AlFuseIn	External Fuse Fail Alarm Input (1 = Active)	uint8	0AE8	2792
LTC.MainPrm.AlTempIn	External Temperature Failure Alarm Input (1 = active)	uint8	0AE9	2793
LTC.MainPrm.IP	Input of LTC block.	float32	0ADE	2782
LTC.MainPrm.OP1	Output1 of the block.	float32	0AE4	2788
LTC.MainPrm.OP2	Output2 of the block.	float32	0AE5	2789
LTC.MainPrm.OP3	Output3 of the block.	float32	0AE6	2790
LTC.MainPrm.OP4	Output4 of the block.	float32	0AE7	2791
LTC.MainPrm.PAOP	Phase angle input for PA reduction in burst firing	float32	0ADF	2783
LTC.MainPrm.S1	Turn ratio of tap1.	float32	0AE0	2784
LTC.MainPrm.S2	Turn ratio of tap2.	float32	0AE1	2785
LTC.MainPrm.S3	Turn ratio of tap3.	float32	0AE2	2786
LTC.MainPrm.S4	Turn ratio of tap4.	float32	0AE3	2787
LTC.MainPrm.TapNb	Transformer tap number (2 = 2, 3 = 3, 4 = 4)	uint8	0ADD	2781
LTC.MainPrm.Type	LTC Type (0 = Primary, 1 = Secondary)	uint8	0ADC	2780
Math2.1.Fallback	Fallback strategy 0 = ClipBad 1 = ClipGood 2 = FallBad 3 = FallGood 4 = UpscaleBad 6 = DownscaleBad	uint8	08C2	2242
Math2.1.FallbackVal	Fallback Value	float32	08BB	2235
Math2.1.HighLimit	Output High Limit	float32	08BC	2236
Math2.1.In1	Input 1 Value	float32	08B7	2231
Math2.1.In1Mul	Input 1 Scale	float32	08B6	2230
Math2.1.In2	Input 2 Value	float32	08B9	2233
Math2.1.In2Mul	Input 2 Scale	float32	08B8	2232
Math2.1.LowLimit	Output Low Limit	float32	08BD	2237
Math2.1.Oper	Operator 0 = None 6 = SelMax 12 = Log 1 = Add 7 = SelMin 13 = Ln 2 = Sub 8 = HotSwap 14 = Exp 3 = Mul 9 = SmpHld 15 = 10 x 4 = Div 10 = Power 51 = Sel 1 5 = AbsDif 11 = Sqrt	uint8	08BA	2234
Math2.1.Out	Output Value	float32	08BF	2239
Math2.1.Resolution	Output Resolution uint8 (0 = X, 1 = X.X, 2 = X.XX, 3 = X.XXX, 4 = X.XXXX)	08C0	2240	
Math2.1.Select	Select Between Input 1 (0) and Input 2 (1)	bool	08C3	2243
Math2.1.Status	Status (Good = 0; Bad = 1)	bool	08BE	2238

8.4 PARAMETER TABLE (Cont.)

Parameter path	Description	Type	Hex	Dec
Math2.1.Units	Output Units (0 = None, 1 = Temp, 2 = V, 3 = mV 4 = A, 5 = mA, 6 = pH, 7 = mmHg)	uint8	08C1	2241
Math2.2.Fallback	Fallback strategy (as for Math2.1)	uint8	08DA	2266
Math2.2.FallbackVal	Fallback Value	float32	08D3	2259
Math2.2.HighLimit	Output High Limit	float32	08D4	2260
Math2.2.In1	Input 1 Value	float32	08CF	2255
Math2.2.In1Mul	Input 1 Scale	float32	08CE	2254
Math2.2.In2	Input 2 Value	float32	08D1	2257
Math2.2.In2Mul	Input 2 Scale	float32	08D0	2256
Math2.2.LowLimit	Output Low Limit	float32	08D5	2261
Math2.2.Oper	Operator (as for Math2.1) 2258	uint8		08D2
Math2.2.Out	Output Value	float32	08D7	2263
Math2.2.Resolution	Output Resolution (as for Math2.1)	uint8	08D8	2264
Math2.2.Select	Select Between Input 1 (0) and Input 2 (1)	bool	08DB	2267
Math2.2.Status	Status (Good = 0; Bad = 1)	bool	08D6	2262
Math2.2.Units	Output Units (as for Math2.1)	uint8	08D9	2265
Math2.3.Fallback	Fallback strategy (as for Math2.1)	uint8	08F2	2290
Math2.3.FallbackVal	Fallback Value	float32	08EB	2283
Math2.3.HighLimit	Output High Limit	float32	08EC	2284
Math2.3.In1	Input 1 Value	float32	08E7	2279
Math2.3.In1Mul	Input 1 Scale	float32	08E6	2278
Math2.3.In2	Input 2 Value	float32	08E9	2281
Math2.3.In2Mul	Input 2 Scale	float32	08E8	2280
Math2.3.LowLimit	Output Low Limit	float32	08ED	2285
Math2.3.Oper	Operator (as for Math2.1)	uint8	08EA	2282
Math2.3.Out	Output Value	float32	08EF	2287
Math2.3.Resolution	Output Resolution (as for Math2.1)	uint8	08F0	2288
Math2.3.Select	Select Between Input 1 (0) and Input 2 (1)	bool	08F3	2291
Math2.3.Status	Status (Good = 0; Bad = 1)	bool	08EE	2286
Math2.3.Units	Output Units (as for Math2.1)	uint8	08F1	2289
Math2.4.Fallback	Fallback strategy (as for Math2.1)	uint8	090A	2314
Math2.4.FallbackVal	Fallback Value	float32	0903	2307
Math2.4.HighLimit	Output High Limit	float32	0904	2308
Math2.4.In1	Input 1 Value	float32	08FF	2303
Math2.4.In1Mul	Input 1 Scale	float32	08FE	2302
Math2.4.In2	Input 2 Value	float32	0901	2305
Math2.4.In2Mul	Input 2 Scale	float32	0900	2304
Math2.4.LowLimit	Output Low Limit	float32	0905	2309
Math2.4.Oper	Operation (as for Math2.1)	uint8	0902	2306
Math2.4.Out	Output Value	float32	0907	2311
Math2.4.Resolution	Output Resolution (as for Math2.1)	uint8	0908	2312
Math2.4.Select	Select Between Input 1 (0) and Input 2 (1)	bool	090B	2315
Math2.4.Status	Status (0 = Good, 1 = Bad)	bool	0906	2310
Math2.4.Units	Output Units (as for Math2.1)	uint8	0909	2313
Modultr.1.CycleTime	Cycle time for fixed modulator	uint16	045F	1119
Modultr.1.In	Input of the modulator block	float32	045D	1117
Modultr.1.LgcMode	Logic mode cycle selection (0 = 1/2 cycle, 1 = Full cycle)	uint8	0460	1120
Modultr.1.MinOnTime	Minimum on time for variable modulator	uint16	045E	1118
Modultr.1.Mode	Modulator mode (0 = IHC, 1 = BurstVar, 2 = BurstFix, 3 = Lgc, 4 = PA)	uint8	0462	1122
Modultr.1.Out	Modulator logical output	float32	045C	1116
Modultr.1.PLMin	Load management interface input	uint16	0461	1121
Modultr.1.SwitchPA	Switch Burst PA (0 = Burst, 1 = PA)	uint8	0466	1126

8.4 PARAMETER TABLE (Cont.)

Parameter path	Description	Type	Hex	Dec
Modultr.2.CycleTime	Cycle time for fixed modulator	uint16	0475	1141
Modultr.2.In	Input of the modulator block	float32	0473	1139
Modultr.2.LgcMode	Logic mode cycle selection (as Modultr1)	uint8	0476	1142
Modultr.2.MinOnTime	Minimum on time for variable modulator	uint16	0474	1140
Modultr.2.Mode	Modulator mode (as Modultr1)	uint8	0478	1144
Modultr.2.Out	Modulator logical output	float32	0472	1138
Modultr.2.PLMin	Load management interface input	uint16	0477	1143
Modultr.2.SwitchPA	Switch Burst PA (as Modultr1)	uint8	047C	1148
Modultr.3.CycleTime	Cycle time for fixed modulator	uint16	048B	1163
Modultr.3.In	Input of the modulator block	float32	0489	1161
Modultr.3.LgcMode	Logic mode cycle selection (as Modultr1)	uint8	048C	1164
Modultr.3.MinOnTime	Minimum on time for variable modulator	uint16	048A	1162
Modultr.3.Mode	Modulator mode (as Modultr1)	uint8	048E	1166
Modultr.3.Out	Modulator logical output	float32	0488	1160
Modultr.3.PLMin	Load management interface input	uint16	048D	1165
Modultr.3.SwitchPA	Switch Burst PA (as Modultr1)	uint8	0492	1170
Modultr.4.CycleTime	Cycle time for fixed modulator	uint16	04A1	1185
Modultr.4.In	Input of the modulator block	float32	049F	1183
Modultr.4.LgcMode	Logic mode cycle selection (as Modultr1)	uint8	04A2	1186
Modultr.4.MinOnTime	Minimum on time for variable modulator	uint16	04A0	1184
Modultr.4.Mode	Modulator mode (as Modultr1)	uint8	04A4	1188
Modultr.4.Out	Modulator logical output	float32	049E	1182
Modultr.4.PLMin	Load management interface input	uint16	04A3	1187
Modultr.4.SwitchPA	Switch Burst PA (as Modultr1)	uint8	04A8	1192
Network.1.AlmAck.ChopOff	Process alarm ack: Chop Off (0 = NoAck, 1 = Ack)	uint8	0187	391
Network.1.AlmAck.FreqFault	System alarm ack: Frequency Fault (as ChopOff)	uint8	0184	388
Network.1.AlmAck.FuseBlown	System alarm ack: Fuse Blown (as ChopOff)	uint8	0181	385
Network.1.AlmAck.MainsVoltFault	Process alarm ack: Mains Voltage Fault (as ChopOff)	uint8	018A	394
Network.1.AlmAck.MissMains	System alarm ack: Missing Mains (as ChopOff)	uint8	017E	382
Network.1.AlmAck.NetworkDips	System alarm ack: Mains Voltage Dips (as ChopOff)	uint8	0183	387
Network.1.AlmAck.OpenThyr	System alarm ack: Open Thyristor (as ChopOff)	uint8	0180	384
Network.1.AlmAck.OverCurrent	Indication alarm ack: Over Current (as ChopOff)	uint8	018C	396
Network.1.AlmAck.OverTemp	System alarm ack: Over Temperature (as ChopOff)	uint8	0182	386
Network.1.AlmAck.PB24VFail	System alarm ack: Power Board 24V Failure (as ChopOff)	uint8	0185	389
Network.1.AlmAck.PLF	Process alarm ack: Partial Load Failure (as ChopOff)	uint8	0188	392
Network.1.AlmAck.PLU	Process alarm ack: Partial Load Unbalance (as ChopOff)	uint8	0189	393
Network.1.AlmAck.PreTemp	Process alarm ack: Pre-Temperature (as ChopOff)	uint8	018B	395
Network.1.AlmAck.ThyrSC	System alarm ack: Thyristor Short Circuit (as ChopOff)	uint8	017F	383
Network.1.AlmAck.TLF	Process alarm ack: Total Load Failure (as ChopOff)	uint8	0186	390
Network.1.AlmDet.ChopOff	Process alarm detection status: Chop Off (0 = Inactive, 1 = Active)	uint8	015A	346
Network.1.AlmDet.FreqFault	System alarm detection status: Frequency Fault (0 = Inactive, 1 = Active)	uint8	0157	343
Network.1.AlmDet.FuseBlown	System alarm detection status: Fuse Blown (0 = Inactive, 1 = Active)	uint8	0154	340
Network.1.AlmDet.MainsVoltFault	Process alarm detection status: Mains Voltage Fault (0 = Inactive, 1 = Active)	uint8	015D	349
Network.1.AlmDet.MissMains	System alarm detection status: Missing Mains (0 = Inactive, 1 = Active)	uint8	0151	337
Network.1.AlmDet.NetworkDips	System alarm detection status: Mains Voltage Dips (0 = Inactive, 1 = Active)	uint8	0156	342
Network.1.AlmDet.OpenThyr	System alarm detection status: Open Thyristor (0 = Inactive, 1 = Active)	uint8	0153	339
Network.1.AlmDet.OverCurrent	Indication alarm detection status: Over Current (0 = Inactive, 1 = Active)	uint8	015F	351
Network.1.AlmDet.OverTemp	System alarm detection status: Over Temperature	uint8	0155	341

8.4 PARAMETER TABLE (Cont.)

Parameter path	Description	Type	Hex	Dec
Network.1.AlmDet.PB24VFail	(0 = Inactive, 1 = Active) System alarm detection status: Power Board 24V Failure (0 = Inactive, 1 = Active)	uint8	0158	344
Network.1.AlmDet.PLF	(0 = Inactive, 1 = Active) Process alarm detection status: Partial Load Failure	uint8	015B	347
Network.1.AlmDet.PLU	(0 = Inactive, 1 = Active) Process alarm detection status: Partial Load Unbalance (0 = Inactive, 1 = Active)	uint8	015C	348
Network.1.AlmDet.PreTemp	Process alarm detection Status: Pre-Temperature	uint8	015E	350
Network.1.AlmDet.ThyrSC	(0 = Inactive, 1 = Active) System alarm detection status: Thyristor Short Circuit (0 = Inactive, 1 = Active)	uint8	0152	338
Network.1.AlmDet.TLF	Process alarm detection status: Total Load Failure	uint8	0159	345
Network.1.AlmDis.ChopOff	(0 = Inactive, 1 = Active) Process alarm: Chop Off (0 = Enable, 1 = Disable)	uint8	014B	331
Network.1.AlmDis.FreqFault	System alarm: Frequency Fault (as for ChopOff)	uint8	0148	328
Network.1.AlmDis.FuseBlown	System alarm: Fuse Blown (as for ChopOff)	uint8	0145	325
Network.1.AlmDis.MainsVoltFault	Process alarm: Mains Voltage Fault (as for ChopOff)	uint8	014E	334
Network.1.AlmDis.MissMains	System alarm: Missing Mains (as for ChopOff)	uint8	0142	322
Network.1.AlmDis.NetworkDips	System alarm: Mains Voltage Dips (as for ChopOff)	uint8	0147	327
Network.1.AlmDis.OpenThyr	System alarm: Open Thyristor (as for ChopOff)	uint8	0144	324
Network.1.AlmDis.OverCurrent	Indication alarm: Over Current (as for ChopOff)	uint8	0150	336
Network.1.AlmDis.OverTemp	System alarm: Over Temperature (as for ChopOff)	uint8	0146	326
Network.1.AlmDis.PB24VFail	System alarm: Power Board 24V Failure	uint8	0149	329
Network.1.AlmDis.PLF	(as for ChopOff) Process alarm: Partial Load Failure (as for ChopOff)	uint8	014C	332
Network.1.AlmDis.PLU	Process alarm: Partial Load Unbalance	uint8	014D	333
Network.1.AlmDis.PreTemp	(as for ChopOff) Process alarm: Pre-Temperature (as for ChopOff)	uint8	014F	335
Network.1.AlmDis.ThyrSC	System alarm: Thyristor Short Circuit	uint8	0143	323
Network.1.AlmDis.TLF	(as for ChopOff) Process alarm: Total Load Failure (as for ChopOff)	uint8	014A	330
Network.1.AlmLat.ChopOff	Process alarm latch: Chop Off	uint8	0178	376
Network.1.AlmLat.FreqFault	(0 = NoLatch, 1 = Latch) System alarm latch: Frequency Fault (as for ChopOff)	uint8	0175	373
Network.1.AlmLat.FuseBlown	System alarm latch: Fuse Blown (as for ChopOff)	uint8	0172	370
Network.1.AlmLat.MainsVoltFault	Process alarm latch: Mains Voltage Fault	uint8	017B	379
Network.1.AlmLat.MissMains	(as for ChopOff) System alarm latch: Missing Mains (as for ChopOff)	uint8	016F	367
Network.1.AlmLat.NetworkDips	System alarm latch: Mains Voltage Dips	uint8	0174	372
Network.1.AlmLat.OpenThyr	System alarm latch: Open Thyristor (as for ChopOff)	uint8	0171	369
Network.1.AlmLat.OverCurrent	Indication alarm latch: Over Current	uint8	017D	381
Network.1.AlmLat.OverTemp	(as for ChopOff) System alarm latch: Over Temperature	uint8	0173	371
Network.1.AlmLat.PB24VFail	(as for ChopOff) System alarm latch: Power Board 24V Failure	uint8	0176	374
Network.1.AlmLat.PLF	(as for ChopOff) Process alarm latch: Partial Load Failure	uint8	0179	377
Network.1.AlmLat.PLU	(as for ChopOff) Process alarm latch: Partial Load Unbalance	uint8	017A	378
Network.1.AlmLat.PreTemp	(as for ChopOff) Process alarm latch: Pre-Temperature	uint8	017C	380
Network.1.AlmLat.ThyrSC	(as for ChopOff) System alarm latch: Thyristor Short Circuit	uint8	0170	368
Network.1.AlmLat.TLF	(as for ChopOff) Process alarm latch: Total Load Failure	uint8	0177	375
Network.1.AlmSig.ChopOff	(as for ChopOff) Process alarm signalling status: Chop Off	uint8	0169	361
	(0 = Not latched, 1 = Latched)			

8.4 PARAMETER TABLE (Cont.)

Parameter path	Description	Type	Hex	Dec
Network.1.AlmSig.FreqFault	System alarm signalling status: Frequency Fault 0 = Not Latched 1 = Ph1 latched 2 = Ph2 latched 3 = Ph1&Ph2 latched 4 = Ph3 latched 5 = Ph1&Ph3 latched 6 = Ph2&Ph3 latched 7 = Ph1, Ph2 7 Ph3 latched	uint8	0166	358
Network.1.AlmSig.FuseBlown	System alarm signalling status: Fuse Blown (As FreqFault)	uint8	0163	355
Network.1.AlmSig.MainsVoltFault	Process alarm signalling status: Mains Voltage Fault (As FreqFault)	uint8	016C	364
Network.1.AlmSig.MissMains	System alarm signalling status: Missing Mains (As FreqFault)	uint8	0160	352
Network.1.AlmSig.NetworkDips	System alarm signalling status: Mains Voltage Dips (As FreqFault)	uint8	0165	357
Network.1.AlmSig.OpenThyr	System alarm signalling status: Open Thyristor (As FreqFault)	uint8	0162	354
Network.1.AlmSig.OverCurrent	Indication alarm signalling status: Over Current (As FreqFault)	uint8	016E	366
Network.1.AlmSig.OverTemp	System alarm signalling status: Over Temperature (As FreqFault)	uint8	0164	356
Network.1.AlmSig.PB24VFail	System alarm signalling status: Power Board 24V Failure (As FreqFault)	uint8	0167	359
Network.1.AlmSig.PLF	Process alarm signalling status: Partial Load Failure (As FreqFault)	uint8	016A	362
Network.1.AlmSig.PLU	Process alarm signalling status: Partial Load Unbalance (As ChopOff)	uint8	016B	363
Network.1.AlmSig.PreTemp	Process alarm signalling status: Pre-Temperature (As FreqFault)	uint8	016D	365
Network.1.AlmSig.ThyrSC	System alarm signalling status: Thyristor Short Circuit (As FreqFault)	uint8	0161	353
Network.1.AlmSig.TLF	Process alarm signalling status: Total Load Failure (As FreqFault)	uint8	0168	360
Network.1.AlmStop.ChopOff	Process alarm stop: Chop Off For all Stop parameters: 0 = No stop 1 = Stop	uint8	0196	406
Network.1.AlmStop.FreqFault	System alarm stop: Frequency Fault	uint8	0193	403
Network.1.AlmStop.FuseBlown	System alarm stop: Fuse Blown	uint8	0190	400
Network.1.AlmStop.MainsVoltFault	Process alarm stop: Mains Voltage Fault	uint8	0199	409
Network.1.AlmStop.MissMains	System alarm stop: Missing Mains	uint8	018D	397
Network.1.AlmStop.NetworkDips	System alarm stop: Mains Voltage Dips	uint8	0192	402
Network.1.AlmStop.OpenThyr	System alarm stop: Open Thyristor	uint8	018F	399
Network.1.AlmStop.OverCurrent	Indication alarm stop: Over Current	uint8	019B	411
Network.1.AlmStop.OverTemp	System alarm stop: Over Temperature	uint8	0191	401
Network.1.AlmStop.PB24VFail	System alarm stop: Power Board 24V Failure	uint8	0194	404
Network.1.AlmStop.PLF	Process alarm stop: Partial Load Failure	uint8	0197	407
Network.1.AlmStop.PLU	Process alarm stop: Partial Load Unbalance	uint8	0198	408
Network.1.AlmStop.PreTemp	Process alarm stop: Pre-Temperature	uint8	019A	410
Network.1.AlmStop.ThyrSC	System alarm stop: Thyristor Short Circuit	uint8	018E	398
Network.1.AlmStop.TLF	Process alarm stop: Total Load Failure	uint8	0195	405
Network.1.Meas.Frequency	Frequency of the line	float32	0118	280
Network.1.Meas.HtSinkTemp	Heatsink 1 temperature	float32	011A	282
Network.1.Meas.HtSinkTmp2	Heatsink 2 temperature	float32	011B	283
Network.1.Meas.HtSinkTmp3	Heatsink 3 temperature	float32	011C	284
Network.1.Meas.I	Irms of the load	float32	0103	259
Network.1.Meas.I2	Irms2 of the load	float32	0104	260
Network.1.Meas.I3	Irms3 of the load	float32	0105	261
Network.1.Meas.Iavg	Average value of Irms	float32	0106	262
Network.1.Meas.IrmsMax	Maximum rms current in a 3 phase network.	float32	0120	288
Network.1.Meas.Isq	Square value of the load current	float32	0108	264
Network.1.Meas.IsqBurst	Average square value of load current in burst firing	float32	0107	263
Network.1.Meas.IsqMax	Maximum squared current in a 3 phase network.	float32	0109	265
Network.1.Meas.P	True power measurement.	float32	0111	273

8.4 PARAMETER TABLE (Cont.)

Parameter path	Description	Type	Hex	Dec
Network.1.Meas.PBurst	True Power measurement in burst firing	float32	0110	272
Network.1.Meas.PF	Power Factor	float32	0113	275
Network.1.Meas.Q	Reactive Power	float32	0114	276
Network.1.Meas.S	Apparent power measurement	float32	0112	274
Network.1.Meas.V	Vrms of the load	float32	010A	266
Network.1.Meas.V2	Vrms2 of the load	float32	010B	267
Network.1.Meas.V3	Vrms3 of the load	float32	010C	268
Network.1.Meas.Vavg	Average value of Vrms	float32	010D	269
Network.1.Meas.Vline	Line voltage measurement	float32	0100	256
Network.1.Meas.Vline2	Line voltage measurement	float32	0101	257
Network.1.Meas.Vline3	Line voltage measurement	float32	0102	258
Network.1.Meas.VrmsMax	Maximum rms voltages in the 3 phase network.	float32	0121	289
Network.1.Meas.Vsq	Square value of load voltage	float32	010E	270
Network.1.Meas.VsqBurst	Average square value of the load voltage in burst firing	float32	0119	281
Network.1.Meas.VsqMax	Maximum squared voltages in the 3 phase network.	float32	010F	271
Network.1.Meas.Z	Load impedance	float32	0115	277
Network.1.Meas.Z2	Load impedance2	float32	0116	278
Network.1.Meas.Z3	Load impedance3	float32	0117	279
Network.1.Setup.ChopOffNb	Chop Off Number	uint8	0126	294
Network.1.Setup.ChopOffThreshold1	Chop Off Threshold1	uint8	0124	292
Network.1.Setup.ChopOffThreshold2	Chop Off Threshold2	uint16	0125	293
Network.1.Setup.ChopOffWindow	Chop Off Window	uint16	0127	295
Network.1.Setup.FreqDriftThreshold	Frequency Drift Threshold.	float32	013F	319
Network.1.Setup.HeaterType	Heater type of the load	uint8	012F	303
Network.1.Setup.HeatsinkPreTemp	Heatsink pre alarm temperature threshold	uint8	012A	298
Network.1.Setup.HeatsinkTmax	Maximum temperature of the heatsink	uint8	0122	290
Network.1.Setup.IextScale	External current scale adjustment	float32	0132	306
Network.1.Setup.IMaximum	Maximum Current of the stack 0 = Ext100A 8 = 400A 16 = Ext1300A 1 = Ext160A 9 = 630A 17 = Ext1700A 2 = Ext250A 10 = 500A 18 = Ext2000A 3 = Ext400A 11 = Ext 500A 19 = Ext3000A 4 = Ext630A 12 = 50A 20 = Ext4000A 5 = 100A 13 = Ext50A 21 = Ext5000A 6 = 160A 14 = Ext800A 7 = 250A 15 = Ext1000A	uint8	0136	310
Network.1.Setup.INominal	Nominal current of the stack	float32	0135	309
Network.1.Setup.NetType	The type of network. Set in Instrument.Configuration. (0 = 3Ph, 1 = 1Ph, 2 = 2Ph)	uint8	0133	307
Network.1.Setup.OverIThreshold	Over Current Threshold	uint16	012E	302
Network.1.Setup.OverVoltThreshold	Over voltage threshold	uint8	0128	296
Network.1.Setup.PLFAadjusted	Partial load failure adjusted acknowledge (0 = Not adjusted, 1 = Adjusted)	uint8	012B	299
Network.1.Setup.PLFAadjustReq	Partial load failure adjustment request (0 = No, 7 = Request)	uint8	0131	305
Network.1.Setup.PLFSensitivity	Partial load failure sensitivity	uint8	012C	300
Network.1.Setup.PLUthreshold	Partial load unbalance threshold	uint8	012D	301
Network.1.Setup.UnderVoltThreshold	Under voltage threshold	uint8	0129	297
Network.1.Setup.VdipsThreshold	Voltage Dips Threshold	uint8	0123	291
Network.1.Setup.VextScale	External voltage scale adjustment	float32	0140	320
Network.1.Setup.VlineNominal	Line nominal value	float32	0130	304
Network.1.Setup.VloadNominal	Load Nominal voltage	float32	0134	308
Network.1.Setup.VMaximum	Maximum Voltage of the stack (0 = 600V, 1 = 690V)	uint8	0141	321
Network.1.Setup.Zref	PLF reference load impedance phase 1	float32	0139	313
Network.1.Setup.Zref2	PLF reference load impedance phase 2	float32	013A	314
Network.1.Setup.Zref3	PLF reference load impedance phase 3	float32	013B	315
	Network 2. See Network 1 for enumeration values			
Network.2.AlmAck.ChopOff	Process alarm ack: Chop Off	uint8	022C	556
Network.2.AlmAck.FreqFault	System alarm ack: Frequency Fault	uint8	0229	553

8.4 PARAMETER TABLE (Cont.)

Parameter path	Description	Type	Hex	Dec
Network.2.AlmAck.FuseBlown	System alarm ack: Fuse Blown	uint8	0226	550
Network.2.AlmAck.MainsVoltFault	Process alarm ack: Mains Voltage Fault	uint8	022F	559
Network.2.AlmAck.MissMains	System alarm ack: Missing Mains	uint8	0223	547
Network.2.AlmAck.NetworkDips	System alarm ack: Mains Voltage Dips	uint8	0228	552
Network.2.AlmAck.OpenThyr	System alarm ack: Open Thyristor	uint8	0225	549
Network.2.AlmAck.OverCurrent	Indication alarm ack: Over Current	uint8	0231	561
Network.2.AlmAck.OverTemp	System alarm ack: Over Temperature	uint8	0227	551
Network.2.AlmAck.PB24VFail	System alarm ack: Power Board 24V Failure	uint8	022A	554
Network.2.AlmAck.PLF	Process alarm ack: Partial Load Failure	uint8	022D	557
Network.2.AlmAck.PLU	Process alarm ack: Partial Load Unbalance	uint8	022E	558
Network.2.AlmAck.PreTemp	Process alarm ack: Pre-Temperature	uint8	0230	560
Network.2.AlmAck.ThyrSC	System alarm ack: Thyristor Short Circuit	uint8	0224	548
Network.2.AlmAck.TLF	Process alarm ack: Total Load Failure	uint8	022B	555
Network.2.AlmDet.ChopOff	Process alarm detection status: Chop Off	uint8	01FF	511
Network.2.AlmDet.FreqFault	System alarm detection status: Frequency Fault	uint8	01FC	508
Network.2.AlmDet.FuseBlown	System alarm detection status: Fuse Blown	uint8	01F9	505
Network.2.AlmDet.MainsVoltFault	Process alarm detection Status: Mains Voltage Fault	uint8	0202	514
Network.2.AlmDet.MissMains	System alarm detection status: Missing Mains	uint8	01F6	502
Network.2.AlmDet.NetworkDips	System alarm detection status: Mains Voltage Dips	uint8	01FB	507
Network.2.AlmDet.OpenThyr	System alarm detection status: Open Thyristor	uint8	01F8	504
Network.2.AlmDet.OverCurrent	Indication alarm detection Status: Over Current	uint8	0204	516
Network.2.AlmDet.OverTemp	System alarm detection status: Over Temperature	uint8	01FA	506
Network.2.AlmDet.PB24VFail	System alarm detection status: Power Board 24V Failure	uint8	01FD	509
Network.2.AlmDet.PLF	Process alarm detection status: Partial Load Failure	uint8	0200	512
Network.2.AlmDet.PLU	Process alarm detection status: Partial Load Unbalance	uint8	0201	513
Network.2.AlmDet.PreTemp	Process alarm detection Status: Pre-Temperature	uint8	0203	515
Network.2.AlmDet.ThyrSC	System alarm detection status: Thyristor Short Circuit	uint8	01F7	503
Network.2.AlmDet.TLF	Process alarm detection status: Total Load Failure	uint8	01FE	510
Network.2.AlmDis.ChopOff	Process alarm: Chop Off	uint8	01F0	496
Network.2.AlmDis.FreqFault	System alarm: Frequency Fault	uint8	01ED	493
Network.2.AlmDis.FuseBlown	System alarm: Fuse Blown	uint8	01EA	490
Network.2.AlmDis.MainsVoltFault	Process alarm: Mains Voltage Fault	uint8	01F3	499
Network.2.AlmDis.MissMains	System alarm: Missing Mains	uint8	01E7	487
Network.2.AlmDis.NetworkDips	System alarm: Mains Voltage Dips	uint8	01EC	492
Network.2.AlmDis.OpenThyr	System alarm: Open Thyristor	uint8	01E9	489
Network.2.AlmDis.OverCurrent	Indication alarm: Over Current	uint8	01F5	501
Network.2.AlmDis.OverTemp	System alarm: Over Temperature	uint8	01EB	491
Network.2.AlmDis.PB24VFail	System alarm: Power Board 24V Failure	uint8	01EE	494
Network.2.AlmDis.PLF	Process alarm: Partial Load Failure	uint8	01F1	497
Network.2.AlmDis.PLU	Process alarm: Partial Load Unbalance	uint8	01F2	498
Network.2.AlmDis.PreTemp	Process alarm: Pre-Temperature	uint8	01F4	500
Network.2.AlmDis.ThyrSC	System alarm: Thyristor Short Circuit	uint8	01E8	488
Network.2.AlmDis.TLF	Process alarm: Total Load Failure	uint8	01EF	495
Network.2.AlmLat.ChopOff	Process alarm latch: Chop Off	uint8	021D	541
Network.2.AlmLat.FreqFault	System alarm latch: Frequency Fault	uint8	021A	538
Network.2.AlmLat.FuseBlown	System alarm latch: Fuse Blown	uint8	0217	535
Network.2.AlmLat.MainsVoltFault	Process alarm latch: Mains Voltage Fault	uint8	0220	544
Network.2.AlmLat.MissMains	System alarm latch: Missing Mains	uint8	0214	532
Network.2.AlmLat.NetworkDips	System alarm latch: Mains Voltage Dips	uint8	0219	537
Network.2.AlmLat.OpenThyr	System alarm latch: Open Thyristor	uint8	0216	534
Network.2.AlmLat.OverCurrent	Indication alarm latch: Over Current	uint8	0222	546
Network.2.AlmLat.OverTemp	System alarm latch: Over Temperature	uint8	0218	536
Network.2.AlmLat.PB24VFail	System alarm latch: Power Board 24V Failure	uint8	021B	539
Network.2.AlmLat.PLF	Process alarm latch: Partial Load Failure	uint8	021E	542
Network.2.AlmLat.PLU	Process alarm latch: Partial Load Unbalance	uint8	021F	543
Network.2.AlmLat.PreTemp	Process alarm latch: Pre-Temperature	uint8	0221	545
Network.2.AlmLat.ThyrSC	System alarm latch: Thyristor Short Circuit	uint8	0215	533
Network.2.AlmLat.TLF	Process alarm latch: Total Load Failure	uint8	021C	540
Network.2.AlmSig.ChopOff	Process alarm signalling status: Chop Off	uint8	020E	526
Network.2.AlmSig.FreqFault	System alarm signalling status: Frequency Fault	uint8	020B	523
Network.2.AlmSig.FuseBlown	System alarm signalling status: Fuse Blown	uint8	0208	520

8.4 PARAMETER TABLE (Cont.)

Parameter path	Description	Type	Hex	Dec
Network.2.AlmSig.MainsVoltFault	Process alarm signalling status: Mains Voltage Fault	uint8	0211	529
Network.2.AlmSig.MissMains	System alarm signalling status: Missing Mains	uint8	0205	517
Network.2.AlmSig.NetworkDips	System alarm signalling status: Mains Voltage Dips	uint8	020A	522
Network.2.AlmSig.OpenThyr	System alarm signalling status: Open Thyristor	uint8	0207	519
Network.2.AlmSig.OverCurrent	Indication alarm signalling status: Over Current	uint8	0213	531
Network.2.AlmSig.OverTemp	System alarm signalling status: Over Temperature	uint8	0209	521
Network.2.AlmSig.PB24VFail	System alarm signalling status: Power Board 24V Failure	uint8	020C	524
Network.2.AlmSig.PLF	Process alarm signalling status: Partial Load Failure	uint8	020F	527
Network.2.AlmSig.PLU	Process alarm signalling status: Partial Load Unbalance	uint8	0210	528
Network.2.AlmSig.PreTemp	Process alarm signalling status: Pre-Temperature	uint8	0212	530
Network.2.AlmSig.ThyrSC	System alarm signalling status: Thyristor Short Circuit	uint8	0206	518
Network.2.AlmSig.TLF	Process alarm signalling status: Total Load Failure	uint8	020D	525
Network.2.AlmStop.ChopOff	Process alarm stop: Chop Off	uint8	023B	571
Network.2.AlmStop.FreqFault	System alarm stop: Frequency Fault	uint8	0238	568
Network.2.AlmStop.FuseBlown	System alarm stop: Fuse Blown	uint8	0235	565
Network.2.AlmStop.MainsVoltFault	Process alarm stop: Mains Voltage Fault	uint8	023E	574
Network.2.AlmStop.MissMains	System alarm stop: Missing Mains	uint8	0232	562
Network.2.AlmStop.NetworkDips	System alarm stop: Mains Voltage Dips	uint8	0237	567
Network.2.AlmStop.OpenThyr	System alarm stop: Open Thyristor	uint8	0234	564
Network.2.AlmStop.OverCurrent	Indication alarm stop: Over Current	uint8	0240	576
Network.2.AlmStop.OverTemp	System alarm stop: Over Temperature	uint8	0236	566
Network.2.AlmStop.PB24VFail	System alarm stop: Power Board 24V Failure	uint8	0239	569
Network.2.AlmStop.PLF	Process alarm stop: Partial Load Failure	uint8	023C	572
Network.2.AlmStop.PLU	Process alarm stop: Partial Load Unbalance	uint8	023D	573
Network.2.AlmStop.PreTemp	Process alarm stop: Pre-Temperature	uint8	023F	575
Network.2.AlmStop.ThyrSC	System alarm stop: Thyristor Short Circuit	uint8	0233	563
Network.2.AlmStop.TLF	Process alarm stop: Total Load Failure	uint8	023A	570
Network.2.Meas.Frequency	Frequency of the line	float32	01BD	445
Network.2.Meas.HtSinkTemp	Heatsink 1 temperature	float32	01BF	447
Network.2.Meas.HtSinkTmp2	Heatsink 2 temperature	float32	01C0	448
Network.2.Meas.HtSinkTmp3	Heatsink 3 temperature	float32	01C1	449
Network.2.Meas.I	Irms of the load	float32	01A8	424
Network.2.Meas.I2	Irms2 of the load	float32	01A9	425
Network.2.Meas.I3	Irms3 of the load	float32	01AA	426
Network.2.Meas.Iavg	Average value of Irms	float32	01AB	427
Network.2.Meas.IrmsMax	Maximum rms current in a 3 phase network.	float32	01C5	453
Network.2.Meas.Isq	Square value of the load current	float32	01AD	429
Network.2.Meas.IsqBurst	Average square value of load current in burst firing	float32	01AC	428
Network.2.Meas.IsqMax	Maximum squared current in a 3 phase network.	float32	01AE	430
Network.2.Meas.P	True power measurement.	float32	01B6	438
Network.2.Meas.PBurst	True Power measurement in burst firing	float32	01B5	437
Network.2.Meas.PF	Power Factor	float32	01B8	440
Network.2.Meas.Q	Reactive Power	float32	01B9	441
Network.2.Meas.S	Apparent power measurement	float32	01B7	439
Network.2.Meas.V	Vrms of the load	float32	01AF	431
Network.2.Meas.V2	Vrms2 of the load	float32	01B0	432
Network.2.Meas.V3	Vrms3 of the load	float32	01B1	433
Network.2.Meas.Vavg	Average value of Vrms	float32	01B2	434
Network.2.Meas.Vline	Line voltage measurement	float32	01A5	421
Network.2.Meas.Vline2	Line voltage measurement	float32	01A6	422
Network.2.Meas.Vline3	Line voltage measurement	float32	01A7	423
Network.2.Meas.VrmsMax	Maximum rms voltages in the 3 phase network.	float32	01C6	454
Network.2.Meas.Vsq	Square value of load voltage	float32	01B3	435
Network.2.Meas.VsqBurst	Average square value of the load voltage in burst firing	float32	01BE	446
Network.2.Meas.VsqMax	Maximum squared voltages in the 3 phase network.	float32	01B4	436
Network.2.Meas.Z	Load impedance	float32	01BA	442
Network.2.Meas.Z2	Load impedance2	float32	01BB	443
Network.2.Meas.Z3	Load impedance3	float32	01BC	444
Network.2.Setup.ChopOffNb	Chop Off Number	uint8	01CB	459
Network.2.Setup.ChopOffThreshold1	Chop Off Threshold1	uint8	01C9	457
Network.2.Setup.ChopOffThreshold2	Chop Off Threshold2	uint16	01CA	458

8.4 PARAMETER TABLE (Cont.)

Parameter path	Description	Type	Hex	Dec
Network.2.Setup.ChopOffWindow	Chop Off Window	uint16	01CC	460
Network.2.Setup.FreqDriftThreshold	Frequency Drift Threshold.	float32	01E4	484
Network.2.Setup.HeaterType	Heater type of the load	uint8	01D4	468
Network.2.Setup.HeatsinkPreTemp	Heatsink pre alarm temperature threshold	uint8	01CF	463
Network.2.Setup.HeatsinkTmax	Maximum temperature of the heatsink	uint8	01C7	455
Network.2.Setup.IextScale	External current scale adjustment	float32	01D7	471
Network.2.Setup.IMaximum	Maximum Current of the stack	uint8	01DB	475
Network.2.Setup.INominal	Nominal current of the stack	float32	01DA	474
Network.2.Setup.NetType	The type of network.Set in Instrument.Configuration.	uint8	01D8	472
Network.2.Setup.OverIThreshold	Over Current Threshold	uint16	01D3	467
Network.2.Setup.OverVoltThreshold	Over voltage threshold	uint8	01CD	461
Network.2.Setup.PLFAdjusted	Partial load failure adjusted acknowledge	uint8	01D0	464
Network.2.Setup.PLFAjustReq	Partial load failure adjustment request	uint8	01D6	470
Network.2.Setup.PLFSensitivity	Partial load failure sensitivity	uint8	01D1	465
Network.2.Setup.PLUthreshold	Partial load unbalance threshold	uint8	01D2	466
Network.2.Setup.UnderVoltThreshold	Under voltage threshold	uint8	01CE	462
Network.2.Setup.VdipsThreshold	Voltage Dips Threshold	uint8	01C8	456
Network.2.Setup.VextScale	External voltage scale adjustment	float32	01E5	485
Network.2.Setup.VlineNominal	Line nominal value	float32	01D5	469
Network.2.Setup.VloadNominal	Load Nominal voltage	float32	01D9	473
Network.2.Setup.VMaximum	Maximum Voltage of the stack	uint8	01E6	486
Network.2.Setup.Zref	PLF reference load impedance phase 1	float32	01DE	478
Network.2.Setup.Zref2	PLF reference load impedance phase 2	float32	01DF	479
Network.2.Setup.Zref3	PLF reference load impedance phase 3	float32	01E0	480
	Network 3. See Network 1 for enumeration values			
Network.3.AlmAck.ChopOff	Process alarm ack: Chop Off	uint8	02D1	721
Network.3.AlmAck.FreqFault	System alarm ack: Frequency Fault	uint8	02CE	718
Network.3.AlmAck.FuseBlown	System alarm ack: Fuse Blown	uint8	02CB	715
Network.3.AlmAck.MainsVoltFault	Process alarm ack: Mains Voltage Fault	uint8	02D4	724
Network.3.AlmAck.MissMains	System alarm ack: Missing Mains	uint8	02C8	712
Network.3.AlmAck.NetworkDips	System alarm ack: Mains Voltage Dips	uint8	02CD	717
Network.3.AlmAck.OpenThyr	System alarm ack: Open Thyristor	uint8	02CA	714
Network.3.AlmAck.OverCurrent	Indication alarm ack: Over Current	uint8	02D6	726
Network.3.AlmAck.OverTemp	System alarm ack: Over Temperature	uint8	02CC	716
Network.3.AlmAck.PB24VFail	System alarm ack: Power Board 24V Failure	uint8	02CF	719
Network.3.AlmAck.PLF	Process alarm ack: Partial Load Failure	uint8	02D2	722
Network.3.AlmAck.PLU	Process alarm ack: Partial Load Unbalance	uint8	02D3	723
Network.3.AlmAck.PreTemp	Process alarm ack: Pre-Temperature	uint8	02D5	725
Network.3.AlmAck.ThyrSC	System alarm ack: Thyristor Short Circuit	uint8	02C9	713
Network.3.AlmAck.TLF	Process alarm ack: Total Load Failure	uint8	02D0	720
Network.3.AlmDet.ChopOff	Process alarm detection status: Chop Off	uint8	02A4	676
Network.3.AlmDet.FreqFault	System alarm detection status: Frequency Fault	uint8	02A1	673
Network.3.AlmDet.FuseBlown	System alarm detection status: Fuse Blown	uint8	029E	670
Network.3.AlmDet.MainsVoltFault	Process alarm detection status: Mains Voltage Fault	uint8	02A7	679
Network.3.AlmDet.MissMains	System alarm detection status: Missing Mains	uint8	029B	667
Network.3.AlmDet.NetworkDips	System alarm detection status: Mains Voltage Dips	uint8	02A0	672
Network.3.AlmDet.OpenThyr	System alarm detection status: Open Thyristor	uint8	029D	669
Network.3.AlmDet.OverCurrent	Indication alarm detection Status: Over Current	uint8	02A9	681
Network.3.AlmDet.OverTemp	System alarm detection status: Over Temperature	uint8	029F	671
Network.3.AlmDet.PB24VFail	System alarm detection status: Power Board 24V Failure	uint8	02A2	674
Network.3.AlmDet.PLF	Process alarm detection status: Partial Load Failure	uint8	02A5	677
Network.3.AlmDet.PLU	Process alarm detection status: Partial Load Unbalance	uint8	02A6	678
Network.3.AlmDet.PreTemp	Process alarm detection Status: Pre-Temperature	uint8	02A8	680
Network.3.AlmDet.ThyrSC	System alarm detection status: Thyristor Short Circuit	uint8	029C	668
Network.3.AlmDet.TLF	Process alarm detection status: Total Load Failure	uint8	02A3	675
Network.3.AlmDis.ChopOff	Process alarm: Chop Off	uint8	0295	661
Network.3.AlmDis.FreqFault	System alarm: Frequency Fault	uint8	0292	658
Network.3.AlmDis.FuseBlown	System alarm: Fuse Blown	uint8	028F	655
Network.3.AlmDis.MainsVoltFault	Process alarm: Mains Voltage Fault	uint8	0298	664

8.4 PARAMETER TABLE (Cont.)

Parameter path	Description	Type	Hex	Dec
Network.3.AlmDis.MissMains	System alarm: Missing Mains	uint8	028C	652
Network.3.AlmDis.NetworkDips	System alarm: Mains Voltage Dips	uint8	0291	657
Network.3.AlmDis.OpenThyr	System alarm: Open Thyristor	uint8	028E	654
Network.3.AlmDis.OverCurrent	Indication alarm: Over Current	uint8	029A	666
Network.3.AlmDis.OverTemp	System alarm: Over Temperature	uint8	0290	656
Network.3.AlmDis.PB24VFail	System alarm: Power Board 24V Failure	uint8	0293	659
Network.3.AlmDis.PLF	Process alarm: Partial Load Failure	uint8	0296	662
Network.3.AlmDis.PLU	Process alarm: Partial Load Unbalance	uint8	0297	663
Network.3.AlmDis.PreTemp	Process alarm: Pre-Temperature	uint8	0299	665
Network.3.AlmDis.ThyrSC	System alarm: Thyristor Short Circuit	uint8	028D	653
Network.3.AlmDis.TLF	Process alarm: Total Load Failure	uint8	0294	660
Network.3.AlmLat.ChopOff	Process alarm latch: Chop Off	uint8	02C2	706
Network.3.AlmLat.FreqFault	System alarm latch: Frequency Fault	uint8	02BF	703
Network.3.AlmLat.FuseBlown	System alarm latch: Fuse Blown	uint8	02BC	700
Network.3.AlmLat.MainsVoltFault	Process alarm latch: Mains Voltage Fault	uint8	02C5	709
Network.3.AlmLat.MissMains	System alarm latch: Missing Mains	uint8	02B9	697
Network.3.AlmLat.NetworkDips	System alarm latch: Mains Voltage Dips	uint8	02BE	702
Network.3.AlmLat.OpenThyr	System alarm latch: Open Thyristor	uint8	02BB	699
Network.3.AlmLat.OverCurrent	Indication alarm latch: Over Current	uint8	02C7	711
Network.3.AlmLat.OverTemp	System alarm latch: Over Temperature	uint8	02BD	701
Network.3.AlmLat.PB24VFail	System alarm latch: Power Board 24V Failure	uint8	02C0	704
Network.3.AlmLat.PLF	Process alarm latch: Partial Load Failure	uint8	02C3	707
Network.3.AlmLat.PLU	Process alarm latch: Partial Load Unbalance	uint8	02C4	708
Network.3.AlmLat.PreTemp	Process alarm latch: Pre-Temperature	uint8	02C6	710
Network.3.AlmLat.ThyrSC	System alarm latch: Thyristor Short Circuit	uint8	02BA	698
Network.3.AlmLat.TLF	Process alarm latch: Total Load Failure	uint8	02C1	705
Network.3.AlmSig.ChopOff	Process alarm signalling status: Chop Off	uint8	02B3	691
Network.3.AlmSig.FreqFault	System alarm signalling status: Frequency Fault	uint8	02B0	688
Network.3.AlmSig.FuseBlown	System alarm signalling status: Fuse Blown	uint8	02AD	685
Network.3.AlmSig.MainsVoltFault	Process alarm signalling status: Mains Voltage Fault	uint8	02B6	694
Network.3.AlmSig.MissMains	System alarm signalling status: Missing Mains	uint8	02AA	682
Network.3.AlmSig.NetworkDips	System alarm signalling status: Mains Voltage Dips	uint8	02AF	687
Network.3.AlmSig.OpenThyr	System alarm signalling status: Open Thyristor	uint8	02AC	684
Network.3.AlmSig.OverCurrent	Indication alarm signalling status: Over Current	uint8	02B8	696
Network.3.AlmSig.OverTemp	System alarm signalling status: Over Temperature	uint8	02AE	686
Network.3.AlmSig.PB24VFail	System alarm signalling status: Power Board 24V Failure	uint8	02B1	689
Network.3.AlmSig.PLF	Process alarm signalling status: Partial Load Failure	uint8	02B4	692
Network.3.AlmSig.PLU	Process alarm signalling status: Partial Load Unbalance	uint8	02B5	693
Network.3.AlmSig.PreTemp	Process alarm signalling status: Pre-Temperature	uint8	02B7	695
Network.3.AlmSig.ThyrSC	System alarm signalling status: Thyristor Short Circuit	uint8	02AB	683
Network.3.AlmSig.TLF	Process alarm signalling status: Total Load Failure	uint8	02B2	690
Network.3.AlmStop.ChopOff	Process alarm stop: Chop Off	uint8	02E0	736
Network.3.AlmStop.FreqFault	System alarm stop: Frequency Fault	uint8	02DD	733
Network.3.AlmStop.FuseBlown	System alarm stop: Fuse Blown	uint8	02DA	730
Network.3.AlmStop.MainsVoltFault	Process alarm stop: Mains Voltage Fault	uint8	02E3	739
Network.3.AlmStop.MissMains	System alarm stop: Missing Mains	uint8	02D7	727
Network.3.AlmStop.NetworkDips	System alarm stop: Mains Voltage Dips	uint8	02DC	732
Network.3.AlmStop.OpenThyr	System alarm stop: Open Thyristor	uint8	02D9	729
Network.3.AlmStop.OverCurrent	Indication alarm stop: Over Current	uint8	02E5	741
Network.3.AlmStop.OverTemp	System alarm stop: Over Temperature	uint8	02DB	731
Network.3.AlmStop.PB24VFail	System alarm stop: Power Board 24V Failure	uint8	02DE	734
Network.3.AlmStop.PLF	Process alarm stop: Partial Load Failure	uint8	02E1	737
Network.3.AlmStop.PLU	Process alarm stop: Partial Load Unbalance	uint8	02E2	738
Network.3.AlmStop.PreTemp	Process alarm stop: Pre-Temperature	uint8	02E4	740
Network.3.AlmStop.ThyrSC	System alarm stop: Thyristor Short Circuit	uint8	02D8	728
Network.3.AlmStop.TLF	Process alarm stop: Total Load Failure	uint8	02DF	735
Network.3.Meas.Frequency	Frequency of the line	float32	0262	610
Network.3.Meas.HtSinkTemp	Heatsink 1 temperature	float32	0264	612
Network.3.Meas.HtSinkTmp2	Heatsink 2 temperature	float32	0265	613
Network.3.Meas.HtSinkTmp3	Heatsink 3 temperature	float32	0266	614
Network.3.Meas.I	Irms of the load	float32	024D	589

8.4 PARAMETER TABLE (Cont.)

Parameter path	Description	Type	Hex	Dec
Network.3.Meas.I2	Irms2 of the load	float32	024E	590
Network.3.Meas.I3	Irms3 of the load	float32	024F	591
Network.3.Meas.Iavg	Average value of Irms	float32	0250	592
Network.3.Meas.IrmsMax	Maximum rms current in a 3 phase network.	float32	026A	618
Network.3.Meas.Isq	Square value of the load current	float32	0252	594
Network.3.Meas.IsqBurst	Average square value of load current in burst firing	float32	0251	593
Network.3.Meas.IsqMax	Maximum squared current in a 3 phase network.	float32	0253	595
Network.3.Meas.P	True power measurement.	float32	025B	603
Network.3.Meas.PBurst	True Power measurement in burst firing	float32	025A	602
Network.3.Meas.PF	Power Factor	float32	025D	605
Network.3.Meas.Q	Reactive Power	float32	025E	606
Network.3.Meas.S	Apparent power measurement	float32	025C	604
Network.3.Meas.V	Vrms of the load	float32	0254	596
Network.3.Meas.V2	Vrms2 of the load	float32	0255	597
Network.3.Meas.V3	Vrms3 of the load	float32	0256	598
Network.3.Meas.Vavg	Average value of Vrms	float32	0257	599
Network.3.Meas.Vline	Line voltage measurement	float32	024A	586
Network.3.Meas.Vline2	Line voltage measurement	float32	024B	587
Network.3.Meas.Vline3	Line voltage measurement	float32	024C	588
Network.3.Meas.VrmsMax	Maximum rms voltages in the 3 phase network.	float32	026B	619
Network.3.Meas.Vsq	Square value of load voltage	float32	0258	600
Network.3.Meas.VsqBurst	Average square value of the load voltage in burst firing	float32	0263	611
Network.3.Meas.VsqMax	Maximum squared voltages in the 3 phase network.	float32	0259	601
Network.3.Meas.Z	Load impedance	float32	025F	607
Network.3.Meas.Z2	Load impedance2	float32	0260	608
Network.3.Meas.Z3	Load impedance3	float32	0261	609
Network.3.Setup.ChopOffNb	Chop Off Number	uint8	0270	624
Network.3.Setup.ChopOffThreshold1	Chop Off Threshold1	uint8	026E	622
Network.3.Setup.ChopOffThreshold2	Chop Off Threshold2	uint16	026F	623
Network.3.Setup.ChopOffWindow	Chop Off Window	uint16	0271	625
Network.3.Setup.FreqDriftThreshold	Frequency Drift Threshold.	float32	0289	649
Network.3.Setup.HeaterType	Heater type of the load	uint8	0279	633
Network.3.Setup.HeatsinkPreTemp	Heatsink pre alarm temperature threshold	uint8	0274	628
Network.3.Setup.HeatsinkTmax	Maximum temperature of the heatsink	uint8	026C	620
Network.3.Setup.IextScale	External current scale adjustment	float32	027C	636
Network.3.Setup.IMaximum	Maximum Current of the stack	uint8	0280	640
Network.3.Setup.INominal	Nominal current of the stack	float32	027F	639
Network.3.Setup.NetType	The type of network. Set in Instrument.Configuration.	uint8	027D	637
Network.3.Setup.OverIThreshold	Over Current Threshold	uint16	0278	632
Network.3.Setup.OverVoltThreshold	Over voltage threshold	uint8	0272	626
Network.3.Setup.PLFAdjusted	Partial load failure adjusted acknowledge	uint8	0275	629
Network.3.Setup.PLFAdjustReq	Partial load failure adjustment request	uint8	027B	635
Network.3.Setup.PLFSensitivity	Partial load failure sensitivity	uint8	0276	630
Network.3.Setup.PLUthreshold	Partial load unbalance threshold	uint8	0277	631
Network.3.Setup.UnderVoltThreshold	Under voltage threshold	uint8	0273	627
Network.3.Setup.VdipsThreshold	Voltage Dips Threshold	uint8	026D	621
Network.3.Setup.VextScale	External voltage scale adjustment	float32	028A	650
Network.3.Setup.VlineNominal	Line nominal value	float32	027A	634
Network.3.Setup.VloadNominal	Load Nominal voltage	float32	027E	638
Network.3.Setup.VMaximum	Maximum Voltage of the stack	uint8	028B	651
Network.3.Setup.Zref	PLF reference load impedance phase 1	float32	0283	643
Network.3.Setup.Zref2	PLF reference load impedance phase 2	float32	0284	644
Network.3.Setup.Zref3	PLF reference load impedance phase 3	float32	0285	645
	Network 4. See Network 1 for enumeration values			
Network.4.AlmAck.ChopOff	Process alarm ack: Chop Off	uint8	0376	886
Network.4.AlmAck.FreqFault	System alarm ack: Frequency Fault	uint8	0373	883
Network.4.AlmAck.FuseBlown	System alarm ack: Fuse Blown	uint8	0370	880
Network.4.AlmAck.MainsVoltFault	Process alarm ack: Mains Voltage Fault	uint8	0379	889
Network.4.AlmAck.MissMains	System alarm ack: Missing Mains	uint8	036D	877

8.4 PARAMETER TABLE (Cont.)

Parameter path	Description	Type	Hex	Dec
Network.4.AlmAck.NetworkDips	System alarm ack: Mains Voltage Dips	uint8	0372	882
Network.4.AlmAck.OpenThyr	System alarm ack: Open Thyristor	uint8	036F	879
Network.4.AlmAck.OverCurrent	Indication alarm ack: Over Current	uint8	037B	891
Network.4.AlmAck.OverTemp	System alarm ack: Over Temperature	uint8	0371	881
Network.4.AlmAck.PB24VFail	System alarm ack: Power Board 24V Failure	uint8	0374	884
Network.4.AlmAck.PLF	Process alarm ack: Partial Load Failure	uint8	0377	887
Network.4.AlmAck.PLU	Process alarm ack: Partial Load Unbalance	uint8	0378	888
Network.4.AlmAck.PreTemp	Process alarm ack: Pre-Temperature	uint8	037A	890
Network.4.AlmAck.ThyrSC	System alarm ack: Thyristor Short Circuit	uint8	036E	878
Network.4.AlmAck.TLF	Process alarm ack: Total Load Failure	uint8	0375	885
Network.4.AlmDet.ChopOff	Process alarm detection status: Chop Off	uint8	0349	841
Network.4.AlmDet.FreqFault	System alarm detection status: Frequency Fault	uint8	0346	838
Network.4.AlmDet.FuseBlown	System alarm detection status: Fuse Blown	uint8	0343	835
Network.4.AlmDet.MainsVoltFault	Process alarm detection Status: Mains Voltage Fault	uint8	034C	844
Network.4.AlmDet.MissMains	System alarm detection status: Missing Mains	uint8	0340	832
Network.4.AlmDet.NetworkDips	System alarm detection status: Mains Voltage Dips	uint8	0345	837
Network.4.AlmDet.OpenThyr	System alarm detection status: Open Thyristor	uint8	0342	834
Network.4.AlmDet.OverCurrent	Indication alarm detection Status: Over Current	uint8	034E	846
Network.4.AlmDet.OverTemp	System alarm detection status: Over Temperature	uint8	0344	836
Network.4.AlmDet.PB24VFail	System alarm detection status: Power Board 24V Failure	uint8	0347	839
Network.4.AlmDet.PLF	Process alarm detection status: Partial Load Failure	uint8	034A	842
Network.4.AlmDet.PLU	Process alarm detection status: Partial Load Unbalance	uint8	034B	843
Network.4.AlmDet.PreTemp	Process alarm detection Status: Pre-Temperature	uint8	034D	845
Network.4.AlmDet.ThyrSC	System alarm detection status: Thyristor Short Circuit	uint8	0341	833
Network.4.AlmDet.TLF	Process alarm detection status: Total Load Failure	uint8	0348	840
Network.4.AlmDis.ChopOff	Process alarm: Chop Off	uint8	033A	826
Network.4.AlmDis.FreqFault	System alarm: Frequency Fault	uint8	0337	823
Network.4.AlmDis.FuseBlown	System alarm: Fuse Blown	uint8	0334	820
Network.4.AlmDis.MainsVoltFault	Process alarm: Mains Voltage Fault	uint8	033D	829
Network.4.AlmDis.MissMains	System alarm: Missing Mains	uint8	0331	817
Network.4.AlmDis.NetworkDips	System alarm: Mains Voltage Dips	uint8	0336	822
Network.4.AlmDis.OpenThyr	System alarm: Open Thyristor	uint8	0333	819
Network.4.AlmDis.OverCurrent	Indication alarm: Over Current	uint8	033F	831
Network.4.AlmDis.OverTemp	System alarm: Over Temperature	uint8	0335	821
Network.4.AlmDis.PB24VFail	System alarm: Power Board 24V Failure	uint8	0338	824
Network.4.AlmDis.PLF	Process alarm: Partial Load Failure	uint8	033B	827
Network.4.AlmDis.PLU	Process alarm: Partial Load Unbalance	uint8	033C	828
Network.4.AlmDis.PreTemp	Process alarm: Pre-Temperature	uint8	033E	830
Network.4.AlmDis.ThyrSC	System alarm: Thyristor Short Circuit	uint8	0332	818
Network.4.AlmDis.TLF	Process alarm: Total Load Failure	uint8	0339	825
Network.4.AlmLat.ChopOff	Process alarm latch: Chop Off	uint8	0367	871
Network.4.AlmLat.FreqFault	System alarm latch: Frequency Fault	uint8	0364	868
Network.4.AlmLat.FuseBlown	System alarm latch: Fuse Blown	uint8	0361	865
Network.4.AlmLat.MainsVoltFault	Process alarm latch: Mains Voltage Fault	uint8	036A	874
Network.4.AlmLat.MissMains	System alarm latch: Missing Mains	uint8	035E	862
Network.4.AlmLat.NetworkDips	System alarm latch: Mains Voltage Dips	uint8	0363	867
Network.4.AlmLat.OpenThyr	System alarm latch: Open Thyristor	uint8	0360	864
Network.4.AlmLat.OverCurrent	Indication alarm latch: Over Current	uint8	036C	876
Network.4.AlmLat.OverTemp	System alarm latch: Over Temperature	uint8	0362	866
Network.4.AlmLat.PB24VFail	System alarm latch: Power Board 24V Failure	uint8	0365	869
Network.4.AlmLat.PLF	Process alarm latch: Partial Load Failure	uint8	0368	872
Network.4.AlmLat.PLU	Process alarm latch: Partial Load Unbalance	uint8	0369	873
Network.4.AlmLat.PreTemp	Process alarm latch: Pre-Temperature	uint8	036B	875
Network.4.AlmLat.ThyrSC	System alarm latch: Thyristor Short Circuit	uint8	035F	863
Network.4.AlmLat.TLF	Process alarm latch: Total Load Failure	uint8	0366	870
Network.4.AlmSig.ChopOff	Process alarm signalling status: Chop Off	uint8	0358	856
Network.4.AlmSig.FreqFault	System alarm signalling status: Frequency Fault	uint8	0355	853
Network.4.AlmSig.FuseBlown	System alarm signalling status: Fuse Blown	uint8	0352	850
Network.4.AlmSig.MainsVoltFault	Process alarm signalling status: Mains Voltage Fault	uint8	035B	859
Network.4.AlmSig.MissMains	System alarm signalling status: Missing Mains	uint8	034F	847
Network.4.AlmSig.NetworkDips	System alarm signalling status: Mains Voltage Dips	uint8	0354	852

8.4 PARAMETER TABLE (Cont.)

Parameter path	Description	Type	Hex	Dec
Network.4.AlmSig.OpenThyr	System alarm signalling status: Open Thyristor	uint8	0351	849
Network.4.AlmSig.OverCurrent	Indication alarm signalling status: Over Current	uint8	035D	861
Network.4.AlmSig.OverTemp	System alarm signalling status: Over Temperature	uint8	0353	851
Network.4.AlmSig.PB24VFail	System alarm signalling status: Power Board 24V Failure	uint8	0356	854
Network.4.AlmSig.PLF	Process alarm signalling status: Partial Load Failure	uint8	0359	857
Network.4.AlmSig.PLU	Process alarm signalling status: Partial Load Unbalance	uint8	035A	858
Network.4.AlmSig.PreTemp	Process alarm signalling status: Pre-Temperature	uint8	035C	860
Network.4.AlmSig.ThyrSC	System alarm signalling status: Thyristor Short Circuit	uint8	0350	848
Network.4.AlmSig.TLF	Process alarm signalling status: Total Load Failure	uint8	0357	855
Network.4.AlmStop.ChopOff	Process alarm stop: Chop Off	uint8	0385	901
Network.4.AlmStop.FreqFault	System alarm stop: Frequency Fault	uint8	0382	898
Network.4.AlmStop.FuseBlown	System alarm stop: Fuse Blown	uint8	037F	895
Network.4.AlmStop.MainsVoltFault	Process alarm stop: Mains Voltage Fault	uint8	0388	904
Network.4.AlmStop.MissMains	System alarm stop: Missing Mains	uint8	037C	892
Network.4.AlmStop.NetworkDips	System alarm stop: Mains Voltage Dips	uint8	0381	897
Network.4.AlmStop.OpenThyr	System alarm stop: Open Thyristor	uint8	037E	894
Network.4.AlmStop.OverCurrent	Indication alarm stop: Over Current	uint8	038A	906
Network.4.AlmStop.OverTemp	System alarm stop: Over Temperature	uint8	0380	896
Network.4.AlmStop.PB24VFail	System alarm stop: Power Board 24V Failure	uint8	0383	899
Network.4.AlmStop.PLF	Process alarm stop: Partial Load Failure	uint8	0386	902
Network.4.AlmStop.PLU	Process alarm stop: Partial Load Unbalance	uint8	0387	903
Network.4.AlmStop.PreTemp	Process alarm stop: Pre-Temperature	uint8	0389	905
Network.4.AlmStop.ThyrSC	System alarm stop: Thyristor Short Circuit	uint8	037D	893
Network.4.AlmStop.TLF	Process alarm stop: Total Load Failure	uint8	0384	900
Network.4.Meas.Frequency	Frequency of the line	float32	0307	775
Network.4.Meas.HtSinkTemp	Heatsink 1 temperature	float32	0309	777
Network.4.Meas.HtSinkTmp2	Heatsink 2 temperature	float32	030A	778
Network.4.Meas.HtSinkTmp3	Heatsink 3 temperature	float32	030B	779
Network.4.Meas.I	Irms of the load	float32	02F2	754
Network.4.Meas.I2	Irms2 of the load	float32	02F3	755
Network.4.Meas.I3	Irms3 of the load	float32	02F4	756
Network.4.Meas.Iavg	Average value of Irms	float32	02F5	757
Network.4.Meas.IrmsMax	Maximum rms current in a 3 phase network.	float32	030F	783
Network.4.Meas.Isq	Square value of the load current	float32	02F7	759
Network.4.Meas.IsqBurst	Average square value of load current in burst firing	float32	02F6	758
Network.4.Meas.IsqMax	Maximum squared current in a 3 phase network.	float32	02F8	760
Network.4.Meas.P	True power measurement.	float32	0300	768
Network.4.Meas.PBurst	True Power measurement in burst firing	float32	02FF	767
Network.4.Meas.PF	Power Factor	float32	0302	770
Network.4.Meas.Q	Reactive Power	float32	0303	771
Network.4.Meas.S	Apparent power measurement	float32	0301	769
Network.4.Meas.V	Vrms of the load	float32	02F9	761
Network.4.Meas.V2	Vrms2 of the load	float32	02FA	762
Network.4.Meas.V3	Vrms3 of the load	float32	02FB	763
Network.4.Meas.Vavg	Average value of Vrms	float32	02FC	764
Network.4.Meas.Vline	Line voltage measurement	float32	02EF	751
Network.4.Meas.Vline2	Line voltage measurement	float32	02F0	752
Network.4.Meas.Vline3	Line voltage measurement	float32	02F1	753
Network.4.Meas.VrmsMax	Maximum rms voltages in the 3 phase network.	float32	0310	784
Network.4.Meas.Vsq	Square value of load voltage	float32	02FD	765
Network.4.Meas.VsqBurst	Average square value of the load voltage in burst firing	float32	0308	776
Network.4.Meas.VsqMax	Maximum squared voltages in the 3 phase network.	float32	02FE	766
Network.4.Meas.Z	Load impedance	float32	0304	772
Network.4.Meas.Z2	Load impedance2	float32	0305	773
Network.4.Meas.Z3	Load impedance3	float32	0306	774
Network.4.Setup.ChopOffNb	Chop Off Number	uint8	0315	789
Network.4.Setup.ChopOffThreshold1	Chop Off Threshold1	uint8	0313	787
Network.4.Setup.ChopOffThreshold2	Chop Off Threshold2	uint16	0314	788
Network.4.Setup.ChopOffWindow	Chop Off Window	uint16	0316	790

8.4 PARAMETER TABLE (Cont.)

Parameter path	Description	Type	Hex	Dec
Network.4.Setup.FreqDriftThreshold	Frequency Drift Threshold.	float32	032E	814
Network.4.Setup.HeaterType	Heater type of the load	uint8	031E	798
Network.4.Setup.HeatsinkPreTemp	Heatsink pre alarm temperature threshold	uint8	0319	793
Network.4.Setup.HeatsinkTmax	Maximum temperature of the heatsink	uint8	0311	785
Network.4.Setup.IextScale	External current scale adjustment	float32	0321	801
Network.4.Setup.IMaximum	Maximum Current of the stack	uint8	0325	805
Network.4.Setup.INominal	Nominal current of the stack	float32	0324	804
Network.4.Setup.NetType	The type of network. Set in Instrument.Configuration.	uint8	0322	802
Network.4.Setup.OverIThreshold	Over Current Threshold	uint16	031D	797
Network.4.Setup.OverVoltThreshold	Over voltage threshold	uint8	0317	791
Network.4.Setup.PLFAdjusted	Partial load failure adjusted acknowledge	uint8	031A	794
Network.4.Setup.PLFAdjustReq	Partial load failure adjustment request	uint8	0320	800
Network.4.Setup.PLFSensitivity	Partial load failure sensitivity	uint8	031B	795
Network.4.Setup.PLUthreshold	Partial load unbalance threshold	uint8	031C	796
Network.4.Setup.UnderVoltThreshold	Under voltage threshold	uint8	0318	792
Network.4.Setup.VdipsThreshold	Voltage Dips Threshold	uint8	0312	786
Network.4.Setup.VextScale	External voltage scale adjustment	float32	032F	815
Network.4.Setup.VlineNominal	Line nominal value	float32	031F	799
Network.4.Setup.VloadNominal	Load Nominal voltage	float32	0323	803
Network.4.Setup.VMaximum	Maximum Voltage of the stack	uint8	0330	816
Network.4.Setup.Zref	PLF reference load impedance phase 1	float32	0328	808
Network.4.Setup.Zref2	PLF reference load impedance phase 2	float32	0329	809
Network.4.Setup.Zref3	PLF reference load impedance phase 3	float32	032A	810
PLM.AlmAck.PrOverPs	Indication alarm acknowledge: Pr Over Ps (0 = NoAck, 1 = Ack)	uint8	06C6	1734
PLM.AlmDet.PrOverPs	Indication alarm detection status: Pr Over Ps (0 = Inactive, 1 = Active)	uint8	06C3	1731
PLM.AlmDis.PrOverPs	Indication alarm: Pr Over Ps (0 = Enable, 1 = Disable)	uint8	06C2	1730
PLM.AlmLat.PrOverPs	Indication alarm latch request: Pr Over Ps (0 = NoLatch, 1 = Latch)	uint8	06C5	1733
PLM.AlmSig.PrOverPs	Indication alarm signalling status: Pr Over Ps (0 = Not latched, 1 = Latched)	uint8	06C4	1732
PLM.AlmStop.PrOverPs	Indication alarm stop request: Pr Over Ps (0 = NoStop, 1 = Stop)	uint8	06C7	1735
PLM.Main.Period	Modulation period	uint16	06B2	1714
PLM.Main.Type	Load Management Type (0 = None, 1 = Sharing, 2 = IncrT1, 3 = IncrT2, 4 = RotIncr, 5 = Distr, 6 = IncrDistr, 7 = RotIncrDistr)	uint8	06B1	1713
PLM.Network.Efficiency	Load management efficiency factor	uint8	06C0	1728
PLM.Network.MasterAddr	Address of elected master on the LM network	uint8	06C1	1729
PLM.Network.Pmax	Max power installed on the PLM network	float32	06BC	1724
PLM.Network.Pr	Total power on the network after load shedding	float32	06BF	1727
PLM.Network.Ps	Total amount of power allowed from the network	float32	06BE	1726
PLM.Network.Pt	Total demanded power on the network	float32	06BD	1725
PLM.Network.TotalChannels	Total number of channels on the network	uint8	06BB	1723
PLM.Network.TotalStation	Total number of stations on the LM link	uint8	06BA	1722
PLM.Station.Address	Load management address	uint8	06B3	1715
PLM.Station.NumChan	Number of channels for this station	uint8	06B5	1717
PLM.Station.PLMOut1	PLM Slot1 Interface output	uint16	06B6	1718
PLM.Station.PLMOut2	PLM Slot2 Interface output	uint16	06B7	1719
PLM.Station.PLMOut3	PLM Slot3 Interface output	uint16	06B8	1720
PLM.Station.PLMOut4	PLM Slot4 Interface output	uint16	06B9	1721
PLM.Station.Status	Master or slave station status (0 = Pending, 1 = IsMaster, 2 = IsSlave, 3 = DuplAddr)	uint8	06B4	1716
PLMChan.1.Group	Group in which the channel operates	uint8	06D3	1747
PLMChan.1.PLMIn	PLM Channel Interface Input	uint16	06D5	1749
PLMChan.1.PLMOut	PLM Channel Interface Output	uint16	06D6	1750
PLMChan.1.PZMax	Total Power installed on the channel	float32	06D2	1746

8.4 PARAMETER TABLE (Cont.)

Parameter path	Description	Type	Hex	Dec
PLMChan.1.ShedFactor	Shed Factor of the Channel	uint8	06D4	1748
PLMChan.2.Group	Group in which the channel operates	uint8	06E2	1762
PLMChan.2.LMIn	PLM Channel Interface Input	uint16	06E4	1764
PLMChan.2.LMOut	PLM Channel Interface Output	uint16	06E5	1765
PLMChan.2.PZMax	Total Power installed on the channel	float32	06E1	1761
PLMChan.2.ShedFactor	Shed Factor of the Channel	uint8	06E3	1763
PLMChan.3.Group	Group in which the channel operates	uint8	06F1	1777
PLMChan.3.LMIn	PLM Channel Interface Input	uint16	06F3	1779
PLMChan.3.LMOut	PLM Channel Interface Output	uint16	06F4	1780
PLMChan.3.PZMax	Total Power installed on the channel	float32	06F0	1776
PLMChan.3.ShedFactor	Shed Factor of the Channel	uint8	06F2	1778
PLMChan.4.Group	Group in which the channel operates	uint8	0700	1792
PLMChan.4.LMIn	PLM Channel Interface Input	uint16	0702	1794
PLMChan.4.LMOut	PLM Channel Interface Output	uint16	0703	1795
PLMChan.4.PZMax	Total Power installed on the channel	float32	06FF	1791
PLMChan.4.ShedFactor	Shed Factor of the Channel	uint8	0701	1793
QStart.AnalogIP1Func	Analogue input 1 function 0 = Unused 1 = Setpoint 2 = SetpointLimit 3 = CurrentLimit 4 = VoltageLimit 5 = PowerLimit 6 = Transfer	uint8	084A	2122
QStart.AnalogIP2Func	Analogue input 2 function (as AnalogIP1)	uint8	084B	2123
QStart.AnalogOP1Func	Analogue output 1 function 0 = Unused 1 = True Power 2 = IRMS 3 = VRMS 4 = Resistance	uint8	0848	2120
QStart.DigitalIP2Func	Digital 2 Input function (0 = Unused, 1 = SPSelect 2 = Alarm Ack, 3 = Custom)	uint8	0849	2121
QStart.Energy	Activate the computation of the energy	uint8	0857	2135
QStart.Feedback	Main PV for the control block 0 = Open 1 = V ² 2 = I ² , 3 = True Power 4 = VRMS 5 = IRMS	uint8	0847	2119
QStart.Finish	Finished Quick start configuration (0 = No, 1 = Yes)	uint8	0846	2118
QStart.FiringMode	Firing Mode 0 = None 1 = Phase angle 2 = Logic 3 = Burst Var 4 = Burst fix5 = HC 6 = Custom	uint8	084E	2126
QStart.LoadCurrent	Nominal Current 0 = 16A 1 = 25A 2 = 40A 3 = 50A 4 = 80A 5 = 100A 6 = 125A 7 = 160A 8 = 200A 9 = 250A 10 = 250A 11 = 315A 12 = 400A 13 = Custom 14 = Ext.	uint8	084C	2124
QStart.LoadCurrentVal	Nominal Current	uint16	0856	2134
QStart.LoadType	Load Type (0 = Resistive, 1 = transformer)	uint8	0851	2129
QStart.LoadVoltage	Load Voltage 0 = 100V 1 = 110V 2 = 115V 3 = 120V 4 = 127V 5 = 200V 6 = 208V 7 = 220V 8 = 230V 9 = 240V 10 = 277V 11 = 380V 12 = 400V 13 = 415V 14 = 440V 15 = 460V 16 = 480V 17 = 500V 18 = 575V 19 = 600V 20 = 660V 21 = 690V 22 = Custom	uint8	084D	2125
QStart.Relay1	Relay 1 function (0 = Unused, 1 = Any alarm, 2 = Network alarm, 3 = Fuse blown)	uint8	0850	2128
QStart.Transfer	Transfer Mode (0 = None, 1 = V ² , 2 = I ²)	uint8	084F	2127
SetProv.1.DisRamp	External input for enabling or disabling a ramp (0 = No, 1 = Yes)	uint8	050C	1292
SetProv.1.EngWorkingSP	Working Setpoint when in engineering units	float32	0515	1301
SetProv.1.HiRange	High range of a setpoint	float32	0513	1299
SetProv.1.Limit	Setpoint limit scalar	float32	0511	1297
SetProv.1.LocalSP	Local setpoint	float32	0508	1288
SetProv.1.RampRate	Ramp rate for the setpoint.	float32	050B	1291
SetProv.1.Remote1	Remote setpoint 1	float32	050E	1294
SetProv.1.Remote2	Remote setpoint 2	float32	050F	1295

8.4 PARAMETER TABLE (Cont.)

Parameter path	Description	Type	Hex	Dec
SetProv.1.RemSelect	Remote setpoint selection	uint8	0510	1296
SetProv.1.SPSelect	Setpoint select	uint8	050A	1290
SetProv.1.SPTrack	Enable Setpoint tracking	uint8	0512	1298
SetProv.1.SPUnits	units of the setpoint	uint8	0514	1300
SetProv.1.WorkingSP	Working or active setpoint	float32	0509	1289
SetProv.2.DisRamp	External input for enabling or disabling a ramp (0 = No, 1 = Yes)	uint8	0520	1312
SetProv.2.EngWorkingSP	Working Setpoint when in engineering units	float32	0529	1321
SetProv.2.HiRange	High range of a setpoint	float32	0527	1319
SetProv.2.Limit	Setpoint limit scalar	float32	0525	1317
SetProv.2.LocalSP	Local setpoint	float32	051C	1308
SetProv.2.RampRate	Ramp rate for the setpoint.	float32	051F	1311
SetProv.2.Remote1	Remote setpoint 1	float32	0522	1314
SetProv.2.Remote2	Remote setpoint 2	float32	0523	1315
SetProv.2.RemSelect	Remote setpoint selection	uint8	0524	1316
SetProv.2.SPSelect	Setpoint select	uint8	051E	1310
SetProv.2.SPTrack	Enable Setpoint tracking	uint8	0526	1318
SetProv.2.SPUnits	units of the setpoint	uint8	0528	1320
SetProv.2.WorkingSP	Working or active setpoint	float32	051D	1309
SetProv.3.DisRamp	External input for enabling or disabling a ramp	uint8	0534	1332
SetProv.3.EngWorkingSP	Working Setpoint when in engineering units	float32	053D	1341
SetProv.3.HiRange	High range of a setpoint	float32	053B	1339
SetProv.3.Limit	Setpoint limit scalar	float32	0539	1337
SetProv.3.LocalSP	Local setpoint	float32	0530	1328
SetProv.3.RampRate	Ramp rate for the setpoint.	float32	0533	1331
SetProv.3.Remote1	Remote setpoint 1	float32	0536	1334
SetProv.3.Remote2	Remote setpoint 2	float32	0537	1335
SetProv.3.RemSelect	Remote setpoint selection	uint8	0538	1336
SetProv.3.SPSelect	Setpoint select	uint8	0532	1330
SetProv.3.SPTrack	Enable Setpoint tracking	uint8	053A	1338
SetProv.3.SPUnits	units of the setpoint	uint8	053C	1340
SetProv.3.WorkingSP	Working or active setpoint	float32	0531	1329
SetProv.4.DisRamp	External input for enabling or disabling a ramp (0 = No, 1 = Yes)	uint8	0548	1352
SetProv.4.EngWorkingSP	Working Setpoint when in engineering units	float32	0551	1361
SetProv.4.HiRange	High range of a setpoint	float32	054F	1359
SetProv.4.Limit	Setpoint limit scalar	float32	054D	1357
SetProv.4.LocalSP	Local setpoint	float32	0544	1348
SetProv.4.RampRate	Ramp rate for the setpoint.	float32	0547	1351
SetProv.4.Remote1	Remote setpoint 1	float32	054A	1354
SetProv.4.Remote2	Remote setpoint 2	float32	054B	1355
SetProv.4.RemSelect	Remote setpoint selection	uint8	054C	1356
SetProv.4.SPSelect	Setpoint select	uint8	0546	1350
SetProv.4.SPTrack	Enable Setpoint tracking	uint8	054E	1358
SetProv.4.SPUnits	units of the setpoint	uint8	0550	1360
SetProv.4.WorkingSP	Working or active setpoint	float32	0545	1349
Timer.1.ElapsedTime	Elapsed Time	time32	0916	2326
Timer.1.In	Trigger/Gate input (0 = Off, 1 = On)	bool	091B	2331
Timer.1.Out	Output (0 = Off, 1 = On)	bool	0917	2327
Timer.1.Time	Time	time32	0918	2328
Timer.1.Triggered	Triggered Flag (0 = Off, 1 = On)	bool	0919	2329
Timer.1.Type	Type of Timer (0 = Off, 1 = OnPulse, 2 = OnDelay, 3 = One shot, 4 = MinOnTime)	uint8	091A	2330
Timer.2.ElapsedTime	Elapsed Time	time32	0927	2343
Timer.2.In	Trigger/Gate input (0 = Off, 1 = On)	bool	092C	2348
Timer.2.Out	Output (0 = Off, 1 = On)	bool	0928	2344
Timer.2.Time	Time	time32	0929	2345

8.4 PARAMETER TABLE (Cont.)

Parameter path	Description	Type	Hex	Dec
Timer.2.Triggered	Triggered Flag (0 = Off, 1 = On)	bool	092A	2346
Timer.2.Type	Type of Timer (As Timer.1.Type)	uint8	092B	2347
Timer.3.ElapsedTime	Elapsed Time	time32	0938	2360
Timer.3.In	Trigger/Gate input (0 = Off, 1 = On)	bool	093D	2365
Timer.3.Out	Output (0 = Off, 1 = On)	bool	0939	2361
Timer.3.Time	Time	time32	093A	2362
Timer.3.Triggered	Triggered Flag (0 = Off, 1 = On)	bool	093B	2363
Timer.3.Type	Type of Timer (As Timer.1.Type)	uint8	093C	2364
Timer.4.ElapsedTime	Elapsed Time	time32	0949	2377
Timer.4.In	Trigger/Gate input (0 = Off, 1 = On)	bool	094E	2382
Timer.4.Out	Output (0 = Off, 1 = On)	bool	094A	2378
Timer.4.Time	Time	time32	094B	2379
Timer.4.Triggered	Triggered Flag (0 = Off, 1 = On)	bool	094C	2380
Timer.4.Type	Type of Timer (As Timer.1.Type)	uint8	094D	2381
Total.1.AlarmOut	Alarm Output (0 = Off, 1 = On)	bool	095C	2396
Total.1.AlarmSP	Alarm Setpoint	float32	095A	2394
Total.1.Hold	Hold (0 = No, 1 = Yes)	bool	0961	2401
Total.1.In	Input Value	float32	095F	2399
Total.1.Reset	Reset (0 = No, 1 = Yes)	bool	0962	2402
Total.1.Resolution	Resolution (0 = X, 1 = X.X, 2 = X.XX, 3 = X.XXX, 4 = X.XXX)	uint8	095E	2398
Total.1.Run	Run (0 = No, 1 = Yes)	bool	0960	2400
Total.1.TotalOut	Totalised Output	float32	095B	2395
Total.1.Units	Units 0 = None 1 = Temp 2 = V 3 = mV, 4 = A 5 = mA 6 = pH 7 = mmHg	uint8	095D	2397
Total.2.AlarmOut	Alarm Output (0 = Off, 1 = On)	bool	0971	2417
Total.2.AlarmSP	Alarm Setpoint	float32	096F	2415
Total.2.Hold	Hold (0 = No, 1 = Yes)	bool	0976	2422
Total.2.In	Input Value	float32	0974	2420
Total.2.Reset	Reset (0 = No, 1 = Yes)	bool	0977	2423
Total.2.Resolution	Resolution (as Total.1)	uint8	0973	2419
Total.2.Run	Run (0 = No, 1 = Yes)	bool	0975	2421
Total.2.TotalOut	Totalised Output	float32	0970	2416
Total.2.Units	Units (as Total.1)	uint8	0972	2418
Total.3.AlarmOut	Alarm Output (0 = Off, 1 = On)	bool	0986	2438
Total.3.AlarmSP	Alarm Setpoint	float32	0984	2436
Total.3.Hold	Hold (0 = No, 1 = Yes)	bool	098B	2443
Total.3.In	Input Value	float32	0989	2441
Total.3.Reset	Reset (0 = No, 1 = Yes)	bool	098C	2444
Total.3.Resolution	Resolution (as Total.1)	uint8	0988	2440
Total.3.Run	Run (0 = No, 1 = Yes)	bool	098A	2442
Total.3.TotalOut	Totalised Output	float32	0985	2437
Total.3.Units	Units (as Total.1)	uint8	0987	2439
Total.4.AlarmOut	Alarm Output (0 = Off, 1 = On)	bool	099B	2459
Total.4.AlarmSP	Alarm Setpoint	float32	0999	2457
Total.4.Hold	Hold (0 = No, 1 = Yes)	bool	09A0	2464
Total.4.In	Input Value	float32	099E	2462
Total.4.Reset	Reset (0 = No, 1 = Yes)	bool	09A1	2465
Total.4.Resolution	Resolution (as Total.1)	uint8	099D	2461
Total.4.Run	Run (0 = No, 1 = Yes)	bool	099F	2463
Total.4.TotalOut	Totalised Output	float32	099A	2458
Total.4.Units	Units (as Total.1)	uint8	099C	2460
UsrVal.1.HighLimit	User Value High Limit	float32	07A4	1956
UsrVal.1.LowLimit	User Value Low Limit	float32	07A5	1957
UsrVal.1.Resolution	User Value Display Resolution (0 = X, 1 = X.X, 2 = X.XX, 3 = X.XX, 4 = X.XXX)	uint8	07A3	1955

8.4 PARAMETER TABLE (Cont.)

Parameter path	Description	Type	Hex	Dec
8.4 PARAMETER TABLE (Cont.)				
Parameter path	Description	Type	Hex	Dec
UsrVal.1.Status	User Value Status (0 = Good, 1 = Bad)	bool	07A7	1959
UsrVal.1.Units	Units of the value 0 = None 1 = Temp 2 = V 3 = mV 4 = A 5 = mA 6 = pH 7 = mmHg	uint8	07A2	1954
UsrVal.1.Val	The User Value	float32	07A6	1958
UsrVal.2.HighLimit	User Value High Limit	float32	07B4	1972
UsrVal.2.LowLimit	User Value Low Limit	float32	07B5	1973
UsrVal.2.Resolution	User Value Display Resolution (as User Val 1)	uint8	07B3	1971
UsrVal.2.Status	User Value Status (as User Val 1)	bool	07B7	1975
UsrVal.2.Units	Units of the value (as User Val 1)	uint8	07B2	1970
UsrVal.2.Val	The User Value	float32	07B6	1974
UsrVal.3.HighLimit	User Value High Limit	float32	07C4	1988
UsrVal.3.LowLimit	User Value Low Limit	float32	07C5	1989
UsrVal.3.Resolution	User Value Display Resolution (as UserVal.1)	uint8	07C3	1987
UsrVal.3.Status	User Value Status (as UserVal.1)	bool	07C7	1991
UsrVal.3.Units	Units of the value (as UserVal.1)	uint8	07C2	1986
UsrVal.3.Val	The User Value	float32	07C6	1990
UsrVal.4.HighLimit	User Value High Limit	float32	07D4	2004
UsrVal.4.LowLimit	User Value Low Limit	float32	07D5	2005
UsrVal.4.Resolution	User Value Display Resolution (as UserVal.1)	uint8	07D3	2003
UsrVal.4.Status	User Value Status (as UserVal.1)	bool	07D7	2007
UsrVal.4.Units	Units of the value (as UserVal.1)	uint8	07D2	2002
UsrVal.4.Val	The User Value	float32	07D6	2006

9 PREDICTIVE LOAD MANAGEMENT OPTION

9.1 GENERAL DESCRIPTION

The Predictive Load Management (PLM) system is an assembly of a number of units ('stations') working together in order to minimize transient power demands which could appear on the mains if all the units were independent. The Predictive Load Management system is described in three sections, viz: Load sequencing (section 9.2), Load sharing (section 9.3) and Load shedding (section 9.4)

9.1.1 Load Management layout

A Predictive Load Management system can consist of up to 63 Stations, running a maximum of 64 channels, distributed around the shop floor (maximum cumulative cable length = 100 metres). Each Station manages either up to four single channels, two, 2-leg channels, or one 3-phase channel. One or more of these channels can participate in Load Management whilst other channels run independently. Where more than 64 channels are required, two or more independent networks (each with its own master) must be created. The PLM connector is located behind the driver module door, and Stations are linked together as shown in figures 2.2.1c and 2.2.1f (location and pinout details respectively).

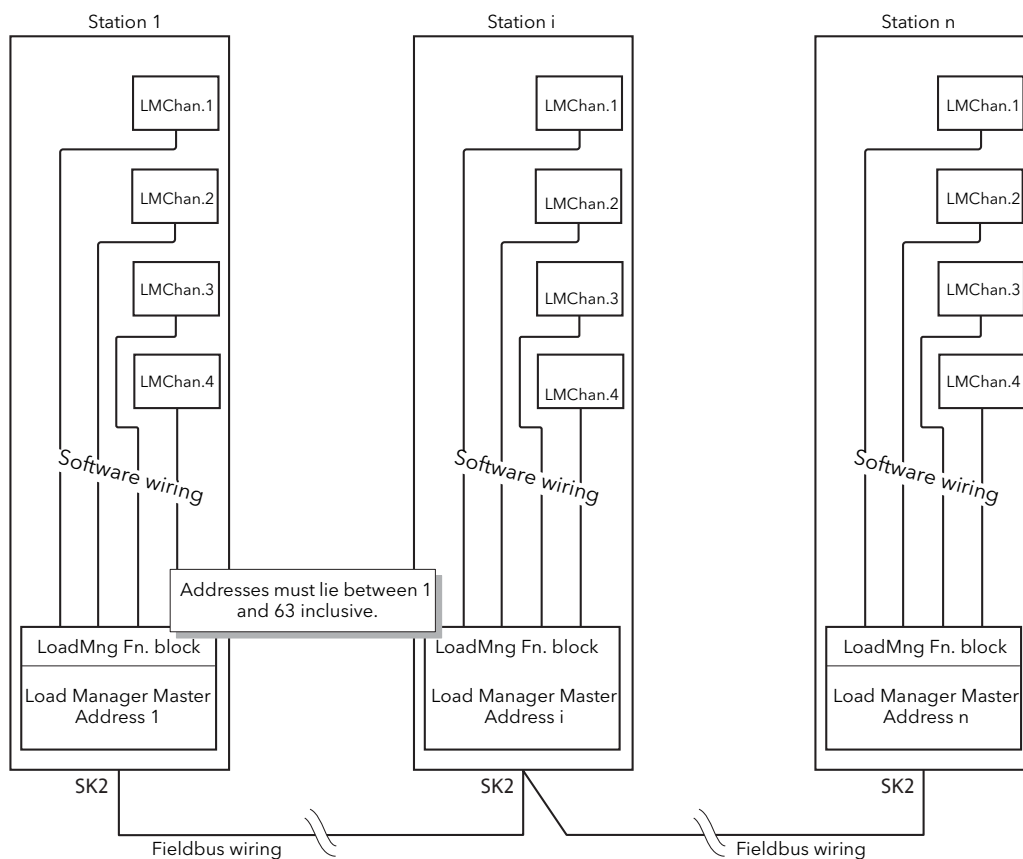

Figure 9.1.1 Predictive Load Management layout (typical)

Notes:

1. Each Station Address must be unique to the PLM communication link, and must be set between 1 and 63 inclusive. Address 0 disables Load Management communications.
2. The figure above shows all four channels used. In reality, any number between 1 and 4 can be set up for Load Management.
3. The Station with the lowest address is deemed to be the master.

9.1.2 Power modulation and accuracy

Fixed modulation is automatically selected for all channels participating to the Load Management. The Modulation period T is constant and is selected (between 50 and 1000 mains periods) during configuration.

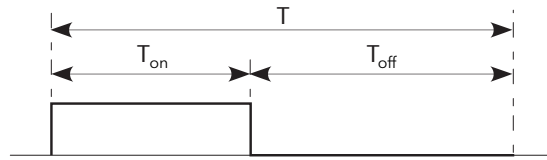

$$\text{Duty cycle} = \eta = \frac{T_{\text{on}}}{T}$$

Figure 9.1.2 Modulation period definitions

T_{on} and T_{off} are related to the Modulation Period (T) and each corresponds to an integer number of mains periods. The duty cycle ($\eta = T_{\text{on}}/T$) defines the power delivered to the load during the Modulation period. T is selected during configuration and its value determines the accuracy of the power control. The default value is 100 cycles.

T (cycles)	Accuracy
50	2%
100	1%
200	0.5%
500	0.2%
1000	0.1%

Table 9.1.2 Accuracy versus modulation period

Note: The value of 'T' is chosen according to the thermal inertia (speed of response) of the load. For loads with high thermal inertia, a long modulation period may be chosen, as the control integration time may be several minutes. Where the load has low inertia, long modulation periods can make the control process unstable if the modulation period approaches the integration time.

9.2 LOAD SEQUENCING

Load sequencing is a time-dependent distribution of Energy through the Load (independent of the installed power per load) in order to avoid big spikes of power demand at the beginning of each conduction period. There are a number of different load sequencing types as described below. Which particular type is chosen depends on the loads being driven. The selection is made in the LoadMng 'Main' area of configuration ([section 6.21.1](#)).

9.2.1 Incremental control type 1

With this kind of control, several Loads receive a common Setpoint. One channel is modulated with the required Duty Cycle η . The remaining channels are at 100% (Full conduction) or at 0% (No conduction). The total power distributed to the Loads is equal to the Setpoint.

For example for 11 Channels and setpoint of 50% (i.e. input of Master channel 1 = 0.5), channels 1 to 5 are continuously on and channels 7 to 11 are continuously off. Channel 6 modulates with a duty cycle of 50% (figure 9.2.1)

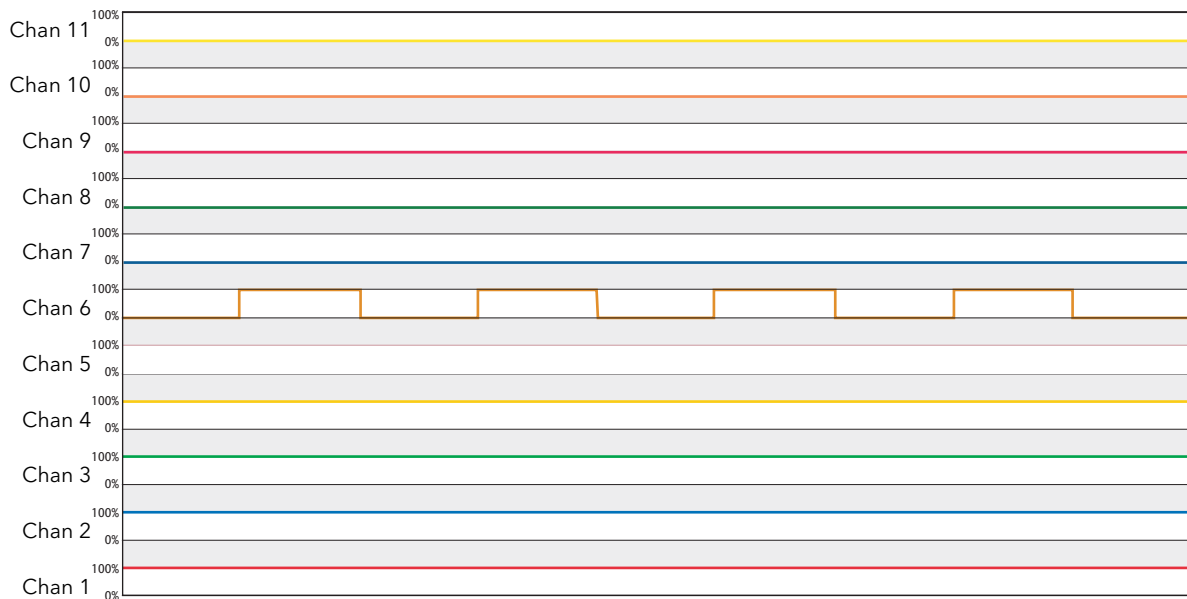

Figure 9.2.1 Incremental control type 1 example

9.2.2 Incremental control type 2

This kind of control, is similar to Incremental control type 1, but the modulated channel is always channel 1. Other channels are always either at 100% (Full conduction) or at 0% (No conduction). The total power distributed to the Loads is equal to the Setpoint.

For example for 11 Channels and setpoint of 50% (i.e. input of Master channel 1 = 0.5), channels 2 to 6 are continuously on and channels 7 to 11 are continuously off. Channel 1 modulates with a duty cycle of 50% (figure 9.2.2)



Figure 9.2.2 Incremental control type 2 example

9.2.3 Rotating Incremental control

This kind of control, is similar to [Incremental control type 1](#), but the modulated channel varies. Non-modulating channels are always either at 100% (Full conduction) or at 0% (No conduction). The total power distributed to the Loads is equal to the Setpoint.

Figure 9.2.3 shows the process for 11 Channels and setpoint = 50% (i.e. input of Master channel 1 = 0.5).

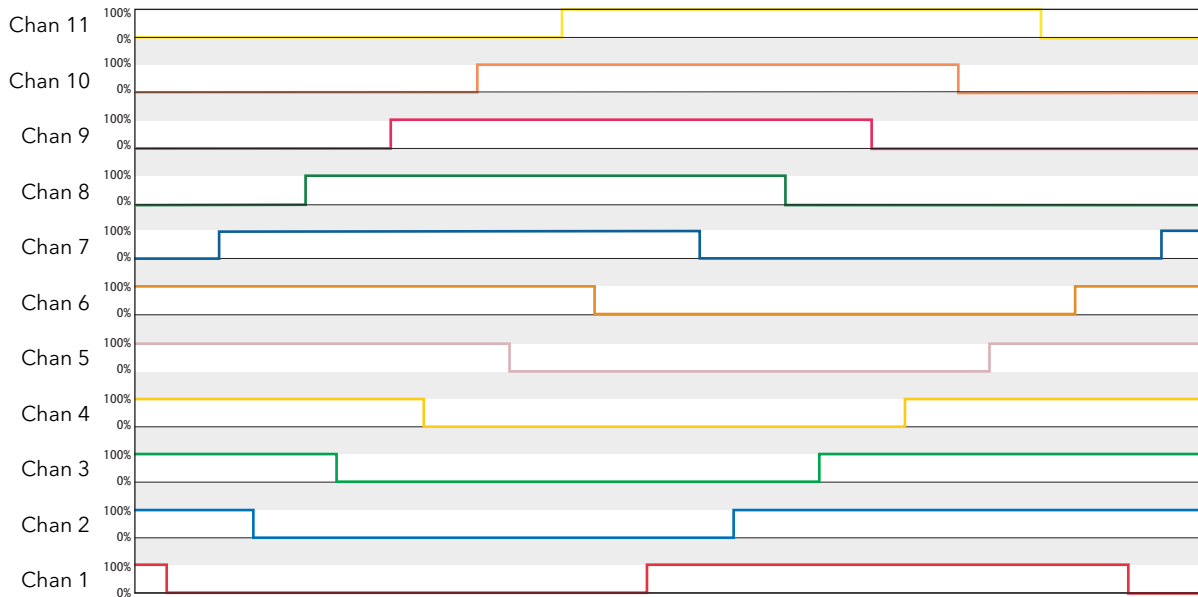

Figure 9.2.3 Rotating incremental control example

9.2.4 Distributed control

With this kind of control, each Load has its own setpoint. In order to avoid simultaneous firing in more than one load, the modulation periods are staggered by a time given by $\tau = T/N$, where T is the modulation period configured by the user, and N is the number of channels.

Note: Load Sharing, described in [section 9.3](#), below is a more efficient solution to this problem.

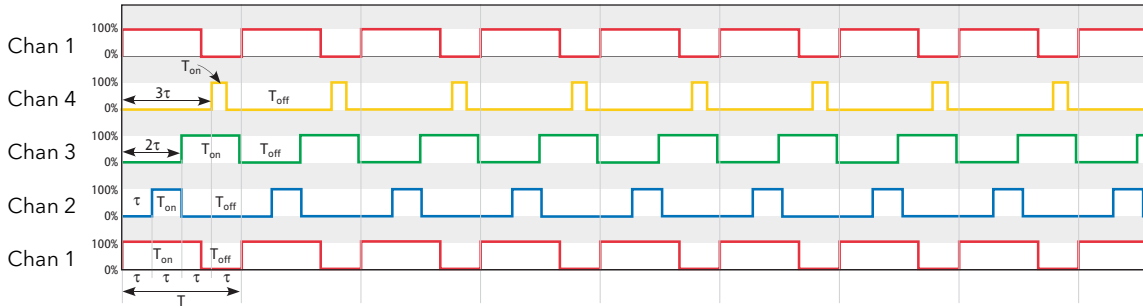

Figure 9.2.4 Distributed control (4 channels) example

9.2.5 Incremental/Distributed control

With this kind of control, Loads are grouped together, with each group having a single setpoint which applies to all the channels in that group. [Incremental control type 2](#) is applied within each group and distributed control is applied to the groups.

Note: The assigning of channels to groups is carried out, for each relevant Load Management channel, via its parameter LMChan 'Group'.

The example in figure 9.2.5a shows 11 channels distributed within two groups.

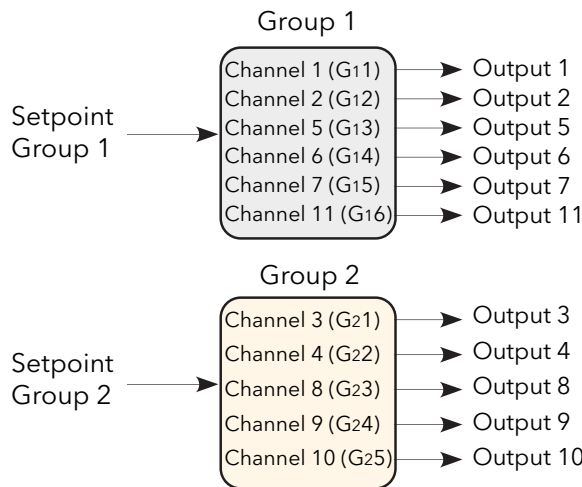

Figure 9.2.5a Channel distribution within groups example

For the six channels in group 1, assuming a set point of 60% (i.e. input of the first channel of group 1 = 0.6). Channel $G_{1,1}$ modulates at 60%; channels $G_{1,2}$ to $G_{1,4}$ are continuously on (100%) and channels $G_{1,5}$ and $G_{1,6}$ are continuously off. That is, channel 1 modulates at 60%, channels 2, 5 and 6 are on, and channels 7 and 11 are off.

9.2.5 INCREMENTAL DISTRIBUTED CONTROL (Cont.)

Similarly for the five channels in group 2, assuming a setpoint of 35% (i.e. unput of the first channel of group 2 = 0.35), Channel G₂1 modulates at 75%; G₂2 is continuously on and G₂3, G₂4 and G₂5 are continuously off. That is, channel 3 is modulating at 75% (off), Channel 4 is continuously on and channels 8, 9 and 10 are continuously off.

The modulation period of group 2 is delayed with respect to that of group 1 by $\tau = T/g$, where $g = 2$ (i.e. $\tau = T/2$).

Note: the modulation period T is a constant for all groups.

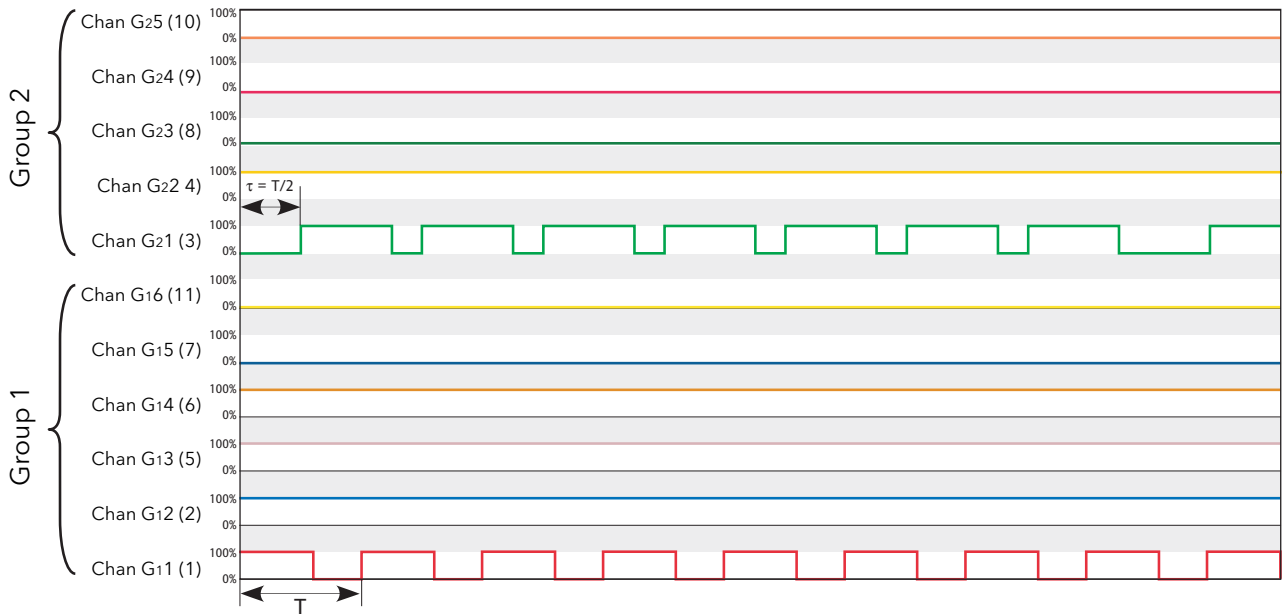

Figure 9.2.5b Incremental distributed control example (two groups)

9.2.6 Rotating Incremental Distributed control

This method of control is similar to 'Incremental distributed control', described above, but within each group, the modulating channel number is incremented every modulation period.

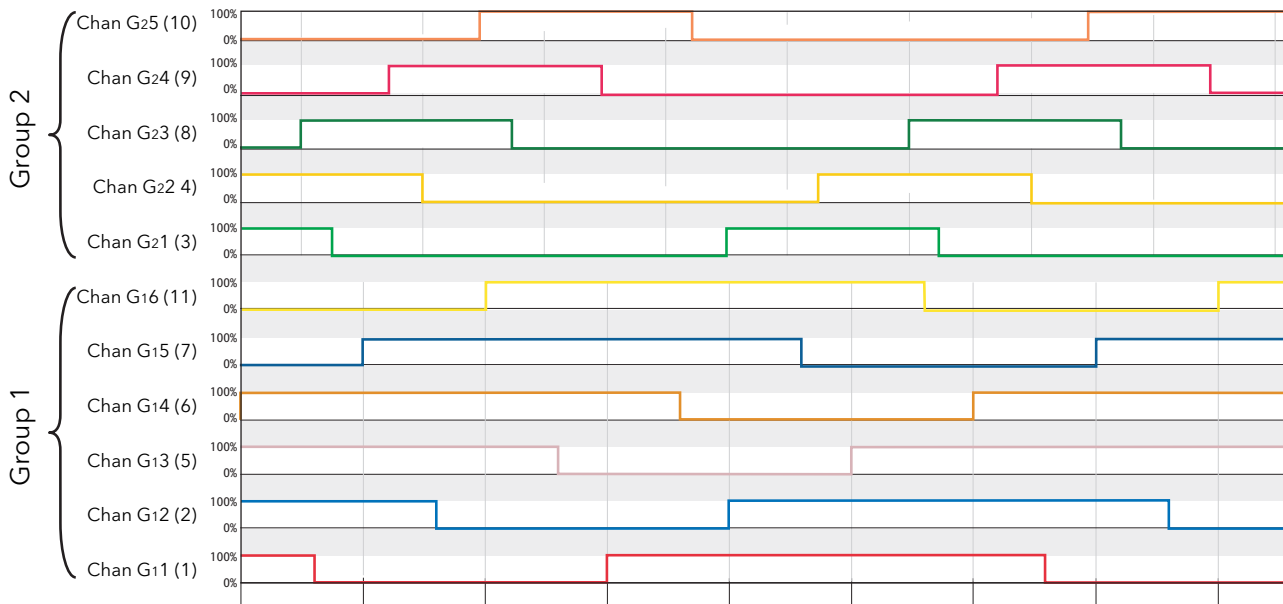

Figure 9.2.6 Rotating Incremental distributed control example (two groups)

9.3 LOAD SHARING

Load Sharing controls the time distribution of Total Power amongst loads, taking into account the amount of Power required by each load.

9.3.1 Total power demand

Each burst of power is defined by three parameters

1. P (Maximum load power) (Depends on line voltage and load impedance: $P=V^2/Z$)
2. η (Duty cycle (T_{on}/T))
3. D (Delay time).

Where more than one load (channel) is being used, the Total power demand varies in a complex way, as can be seen in the simple example, with just two channels, shown in figure 9.3.1 below.

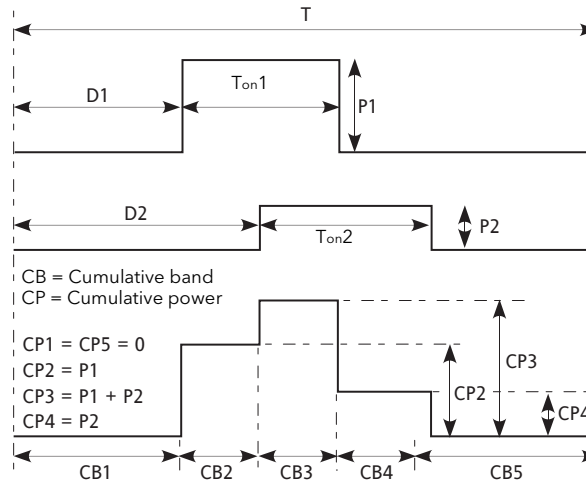

Figure 9.3.1 Total power demand example

9.3.2 Sharing Efficiency Factor (F)

The Sharing Efficiency Factor (F) is defined as follows:

$$F = \frac{P_{max} - (CP_{max} - CP_{min})}{P_{max}}$$

Where CP_{max} is the maximum of all the Cumulative Powers and CP_{min} the minimum. Sharing Efficiency increases as F approaches 1. That is, the closer CP_{max} and CP_{min} are to P_t , the higher the sharing efficiency.

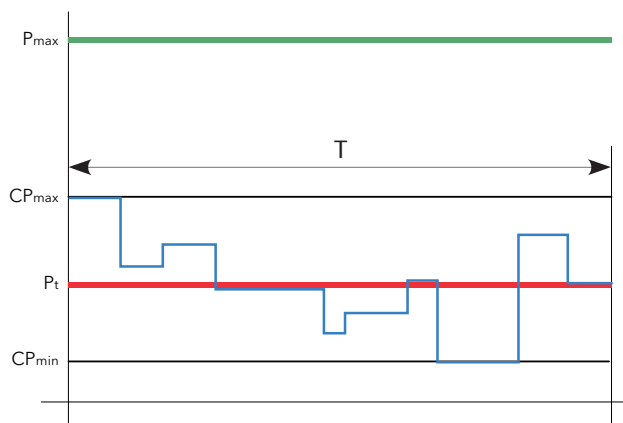

Figure 9.3.2 Sharing efficiency definitions

9.3.3 Sharing algorithm

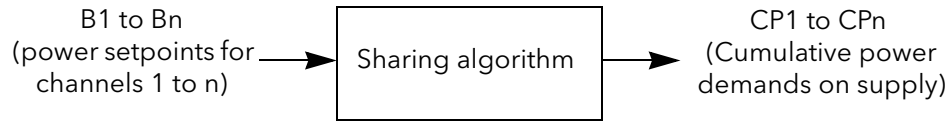

Figure 9.3.3a Sharing algorithm overview

The goal of the “Efficient Power” algorithm is to keep the value of F as close as possible to 1. To achieve this, the following parameters are manipulated:

1. The Delay time (D) for each load modulation
2. The order in which loads are modulated.

The algorithm itself is made of several steps which are computed before each modulation period.

1. The master determines the total number of channels (n)
2. The master determines the setpoint (Power Demand) for each channel. This gives the Duty Cycle and the Max Power of the Load PZmax.
3. Burst Image Initialisation. Each Burst (B_i) is seen as a Rectangle (R_i), where i is between 1 and ‘n’ inclusive. Eventually, these i rectangles will be placed in time, but initially they are not placed.
4. Cumulative Band Initialisation
5. Calculation of P_t and P_{max} from the following equations, where L = duty cycle and H = load power:

$$P_t = \sum_{i=1}^n (R_i L \times R_i H) \quad P_{max} = \sum_{i=1}^n R_i H$$

6. Rectangle placement. Each rectangle is placed and the bands modified in consequence.

The same algorithm is performed several times and iteratively for all the rectangles. From the result, the solution with the best Efficiency Factor is taken as definitive result.

9.4 LOAD SHEDDING

Load Shedding controls the total power distribution amongst loads by reducing the amount of Power distributed for each load so that the global power demanded is less than a given maximum (Ps). Load Shedding and Load Sharing may be used together if required.

9.4.1 Definitions

Pz = the power installed on a particular channel (zone). For channel 'i', Pz is given by the following equation:

$$Pz_{i_{\max}} = \frac{V_i^2}{R_i}$$

This parameter (PZMax) is available to the user in the Block 'LMChan'.

The Total Installed Power is the sum of all the relevant Maximum Load Powers. Thus, for n channels, the total Installed Power on the network (P_{max}) is given by:

$$P_{\max} = \sum_{i=1}^n PZi_{\max}$$

P_{max} is available to the user in the Block 'LoadMng.Network'.

The actual power demanded on channel 'i' depends on the duty cycle as follows:

$$Pt_i = \eta_i \times PZi_{\max}$$

Pt_i is available to the user as parameter 'PBurst' in the Block 'Network.Meas'* if no shedding is applied.

* Note: Not to be confused with 'LoadMng.Network'.

The total power demanded on the Network is:

$$Pt = \sum_{i=1}^n Pt_i$$

This parameter (Pt) is available to the user in the Block 'LoadMng.Network', and represents the Mean Power which would be dissipated in the Load during one Modulation Period, if Load Shedding were not applied.

9.4.2 Reduction of power demand

A further parameter (Ps) is available to the user in the Block 'LoadMng.Network'. Ps is used to restrict the power demanded from the network to an absolute maximum value

For example the total installed power could be 2.5MW, but the user wishes to restrict the delivered power to below a tariff band of 2MW. In such a case Ps would be set to 2MW and power would be shed throughout the network in order to keep the total demand below 2MW.

If Ps > Pmax, load shedding is disabled.

If Ps ≥ Pt, no reduction is applied. If Ps < Pt, each duty cycle (η) is reduced by multiplying it by a reduction factor 'r' given by the equation below. The reduction factor is applied to each channel.

$$r = \frac{Ps}{Pt}$$

9 4 2 REDUCTION OF POWER DEMAND (Cont.)

The resulting Power for a given channel (i) is:

$$Pr_i = r \times \eta_i \times Pt_i$$

The parameter Pr_i is available to the user as 'PBurst' in the Block 'Network.Meas' for each channel.

The resulting power is then:

$$Pr = \sum_{i=1}^n Pr_i$$

This parameter 'Pr' is available to the user in the Block LoadMng.Network.

Note: if all Shedding Ability Factors (see below) are zero, Pr must be close to Ps

SHEDDING ABILITY FACTOR

For some applications, the power demand must be maintained for particular channels. For this reason a parameter called 'Shedding Ability Factor' can be configured for each channel, to define the threshold at which any reducing factor is applied to the channel.

This parameter (ShedFactor) is available to the user in the Block 'LMChan'

The reduction coefficient (r) is recalculated for each channel, in the following way, where 's' is the ShedFactor:

If $s_i > r$, then $r_i = s_i$; If $s_i \leq r$, then $r_i = r$

For example, if $s_i = 100\%$ no reducing coefficient is applied to channel 'i'; if $s_i = 0\%$ the reducing coefficient r is always applied, as it is, to channel 'i'.

The resulting Power for a given channel is now: $Pr_i = r_i \times \eta_i \times Pt_i$

with: $Ps \leq Pr \leq Pt$

Note: If Pr is greater than Ps, due to the shedding ability coefficient applied to some channels on the Network, an indication alarm 'PrOverPs' is issued (see below).

9.4.3 Load shedding comparisons

In this imaginary example, the Network consists of 32 Channels. The Power (PZMax_i) and the Setpoint or Duty Cycle (Power demand η_i) have the values given below during the relevant modulation period of 100 mains cycles. The total installed Power on the Network is Pmax = 1.285MW and the Demanded Power is Pt = 433kW

Channel No.	Setpoint	Power	Channel No.	Setpoint	Power
1	10%	58kW	17	45%	69kW
2	15%	9kW	18	9%	32kW
3	56%	7kW	19	25%	65kW
4	45%	56kW	20	45%	98kW
5	1%	12kW	21	12%	96kW
6	15%	4kW	22	18%	85kW
7	45%	25kW	23	45%	74kW
8	78%	23kW	24	56%	5kW
9	52%	45kW	25	6%	2kW
10	54%	12kW	26	39%	8kW
11	56%	45kW	27	96%	7kW
12	4%	78kW	28	65%	74kW
13	5%	36kW	29	58%	85kW
14	58%	25kW	30	9%	65kW
15	78%	14kW	31	7%	5kW
16	12%	58kW	32	56%	8kW

Table 9.4.3 Channel parameters

WITHOUT LOAD SHARING, SYNCHRONISED

This is the worst case. The simulation in figure 9.4.3a shows the Power profile on the Modulation Period if all the channels are started at the same time (i.e. with no incremental control applied).

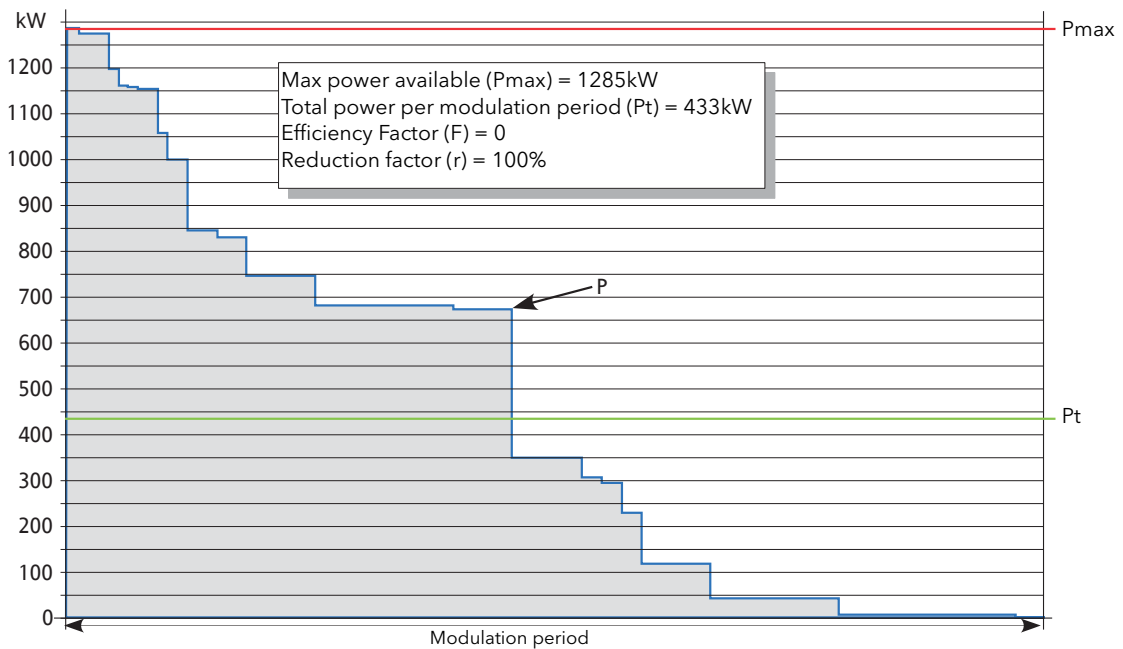

Figure 9.4.3a Synchronised without load sharing (r = 100%)

9.4.3 LOAD SHEDDING COMPARISONS (Cont.)

WITHOUT LOAD SHARING, SYNCHRONISED, REDUCTION FACTOR 50%

Similar to the previous example, but the authorised Power has been set to $P_s = 216\text{kW}$. (Reduction factor 'r' is 50% (0.5)).

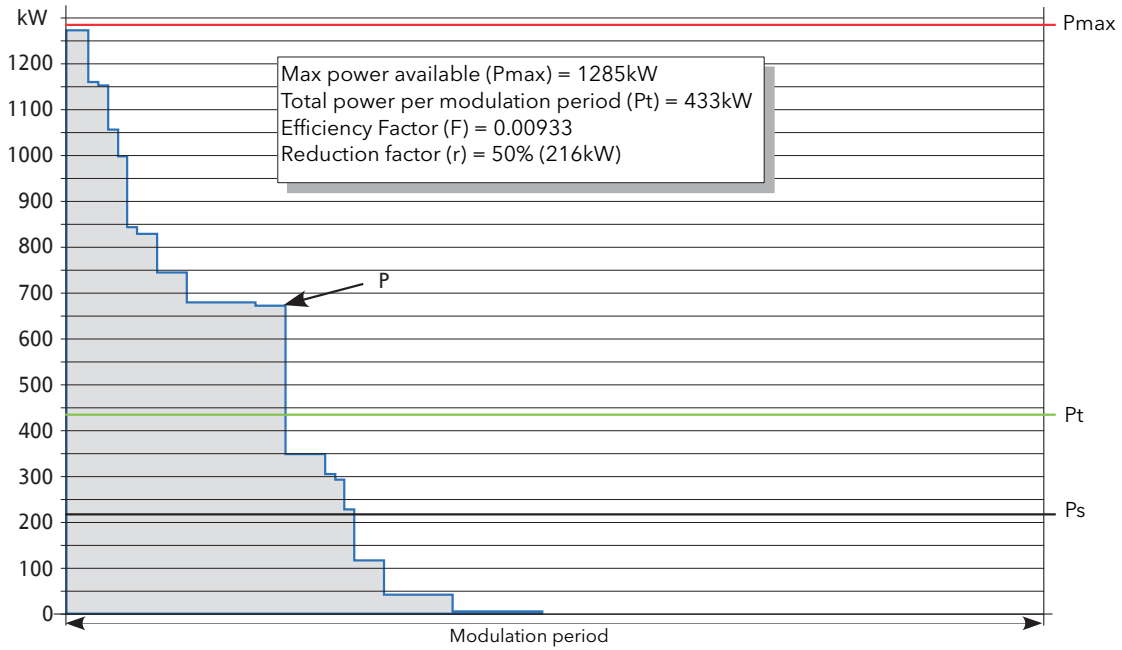

Figure 9.4.3b Synchronised without load sharing (r = 50%)

WITHOUT LOAD SHARING NOT SYNCHRONISED

Because modulation periods start at different times, the power profile may be 'good' for some modulation periods, but poor for others.

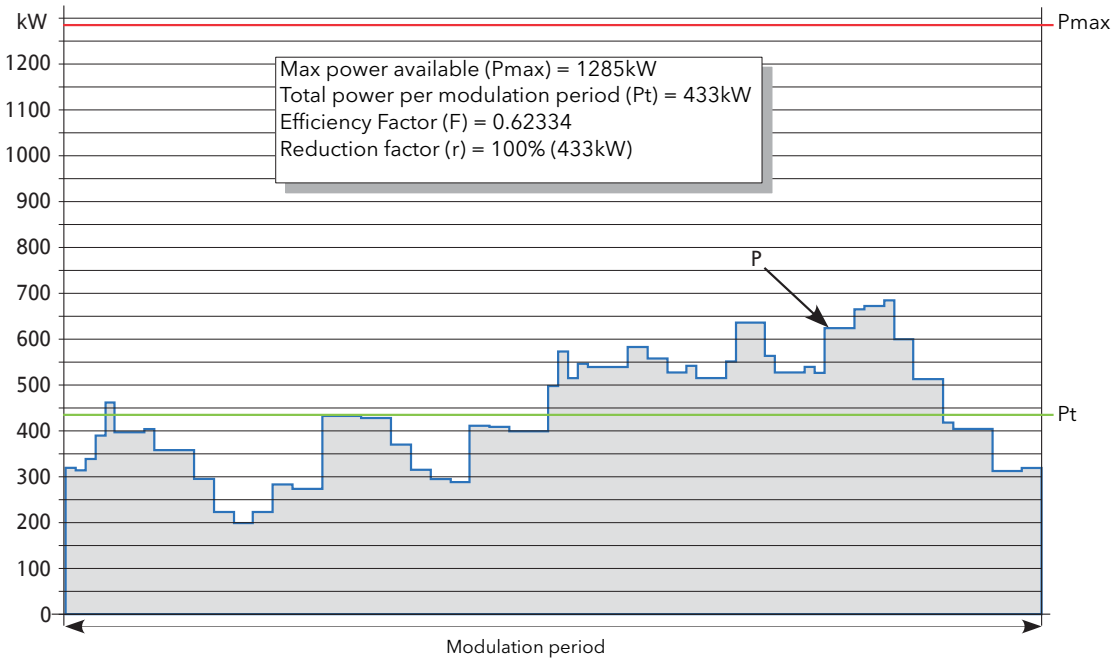

Figure 9.4.3c Non-synchronised without load sharing (r = 100%)

9.4.3 LOAD SHEDDING COMPARISONS (Cont.)

WITHOUT LOAD SHARING, NON-SYNCHRONISED, REDUCTION FACTOR 50%

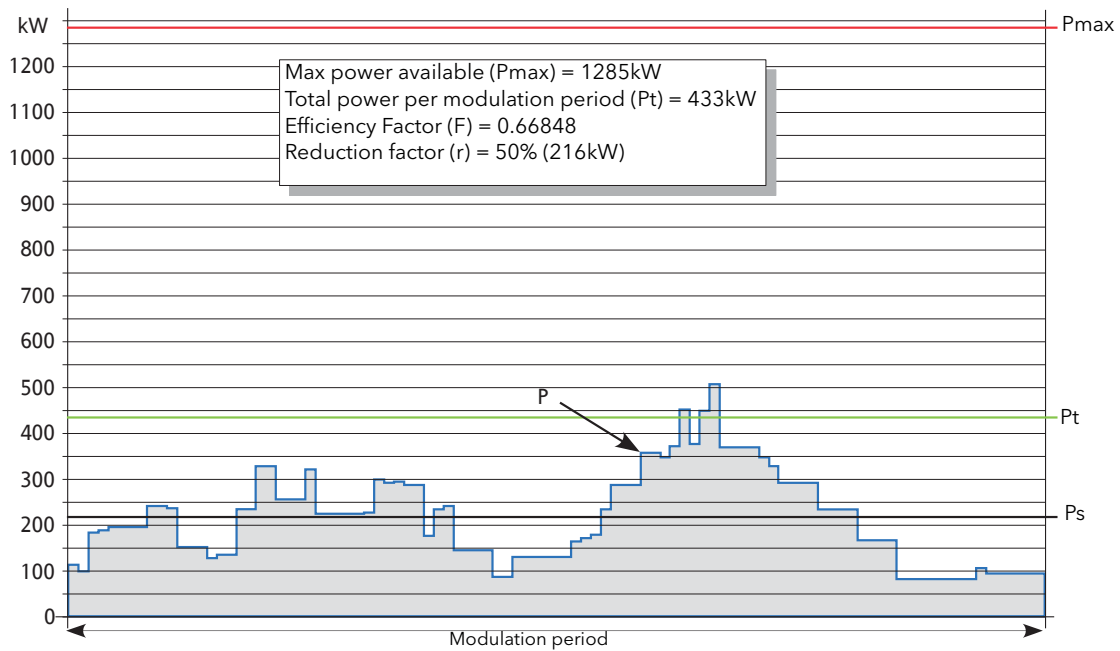

Figure 9.4.3d Non-synchronised without load sharing (r = 50%)

WITH LOAD SHARING

In this example, the Sharing algorithm has been applied. The total power and power demand are the same as in previous examples, but the power profile is approximately flat, with a value close to Pt.

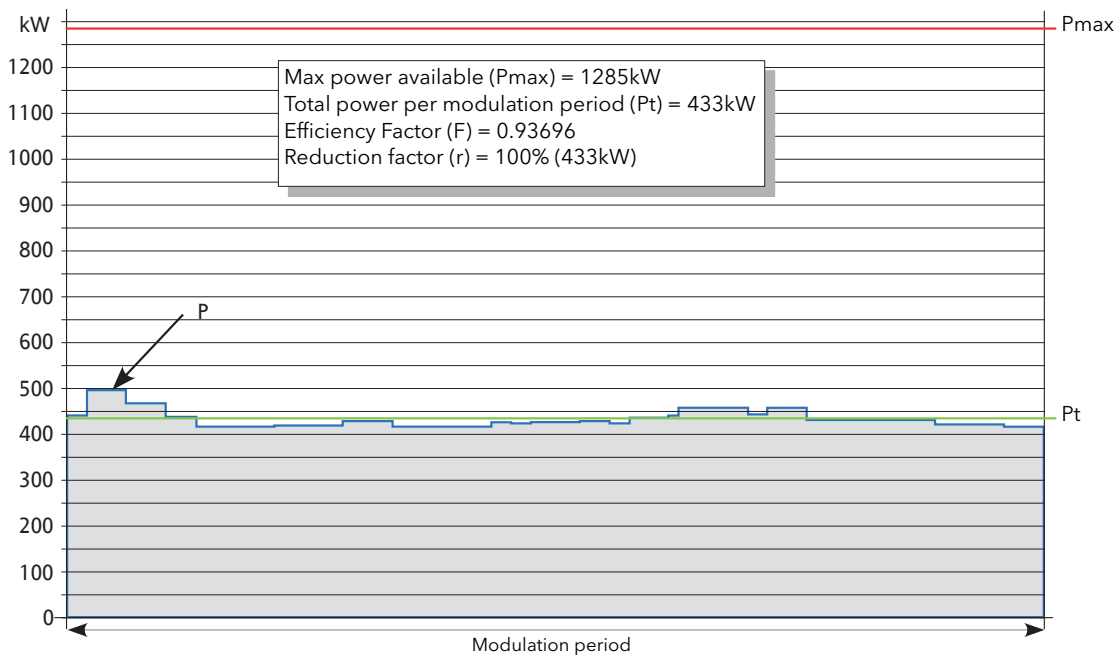

Figure 9.4.3e Load sharing (r = 100%)

9 4 3 LOAD SHEDDING COMPARISONS (Cont.)

WITH LOAD SHARING, REDUCTION FACTOR = 50%

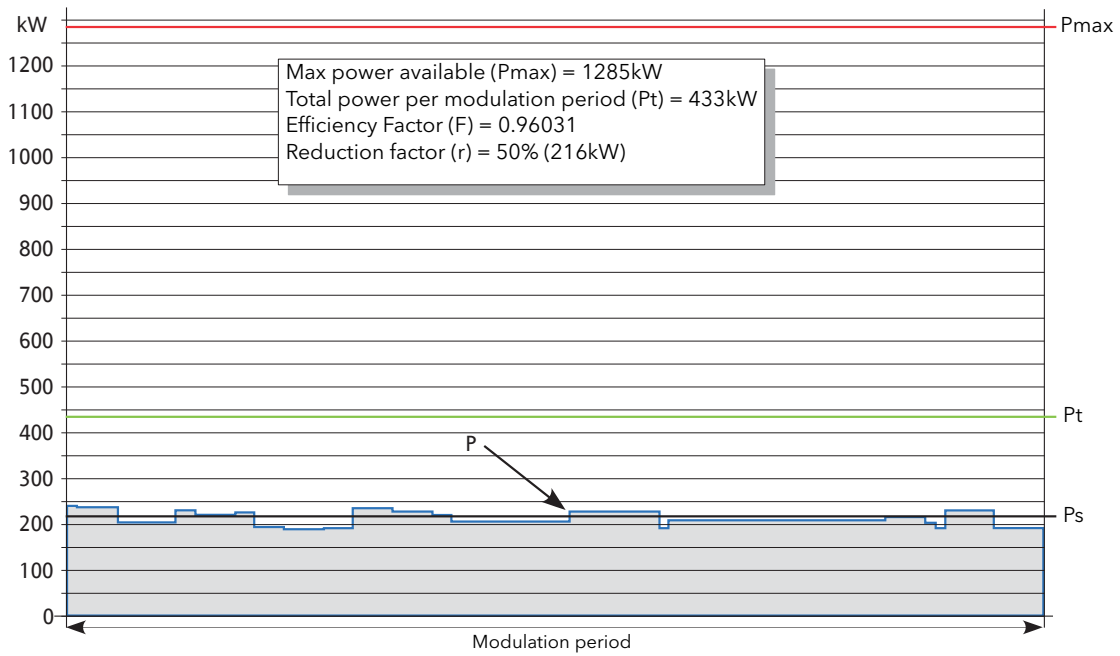

Figure 9.4.3f With load sharing ($r = 50\%$)

In this example, it can be seen that the Sharing algorithm has been re-calculated with the new values. This gives a different shape to the global power distribution but, as with the previous example, the power profile is approximately flat, with a value close to P_s .

9.5 CONFIGURATION

9.5.1 iTools Graphical wiring

Load Management configuration is carried out in the following stages:

STANDARD POWER CONTROL LOOP

Each Channel is built and configured from standard blocks. Figure 9.5.1a shows a typical example.

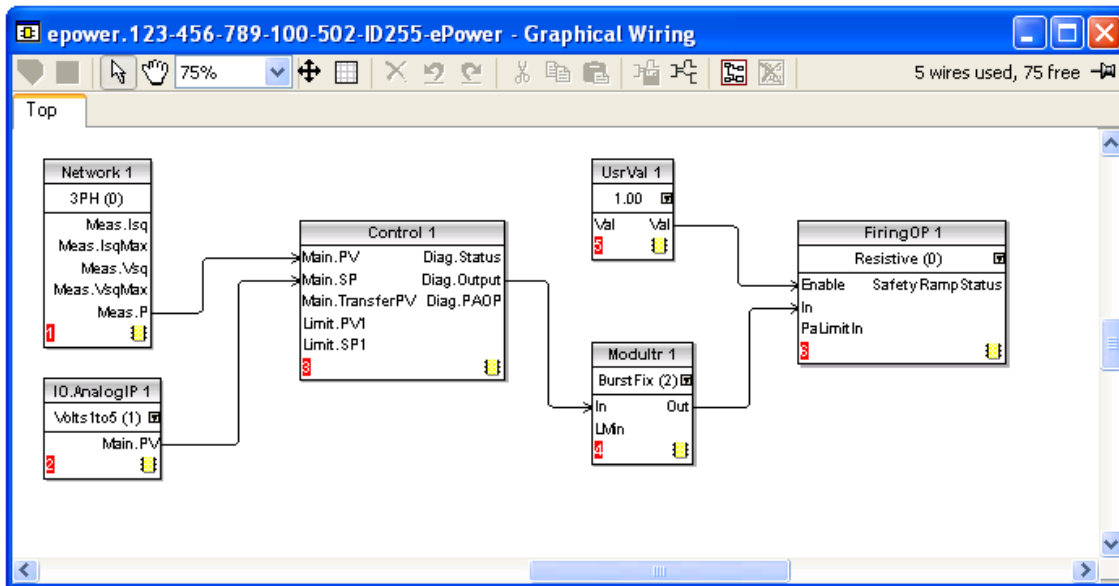

Figure 9.5.1a Control loop wiring in iTools

Each channel may be of any type, single phase, 2-legs or three phase.

Note: Load Management sets the Modulator type to 'BurstFix'. Similarly, Burst length is defined by the LM Master.

LOAD MANAGEMENT CHANNELS (LMCHAN 1 TO LMCHAN 4)

For each Channel, the Modulator Block input 'LMIn' must be wired to the LMout parameter of an LMChan Block. Each channel is then managed by its own LMChan block. Figure 9.5.1b shows a configuration of three single phase control channels.

GLOBAL LOAD MANAGEMENT CONTROL (LOADMNG)

The LoadMng Block is added. Each LMChan LmIn parameter is wired to a LoadMng LMout parameter. Figure 9.5.1c shows the complete configuration

Notes:

1. If a channel is not wired to a slot of the LoadMng block, it doesn't participate to the Load Management process.
2. On a Given Station, it is allowed to mix channels which participate to the PLM process, and channels which do not.

CALCULATION AND COMMUNICATIONS

The Unit performs all the operations needed by the Predictive Load Management process transparently to the user.

9 5 1 iTOOLS GRAPHICAL WIRING (Cont.)

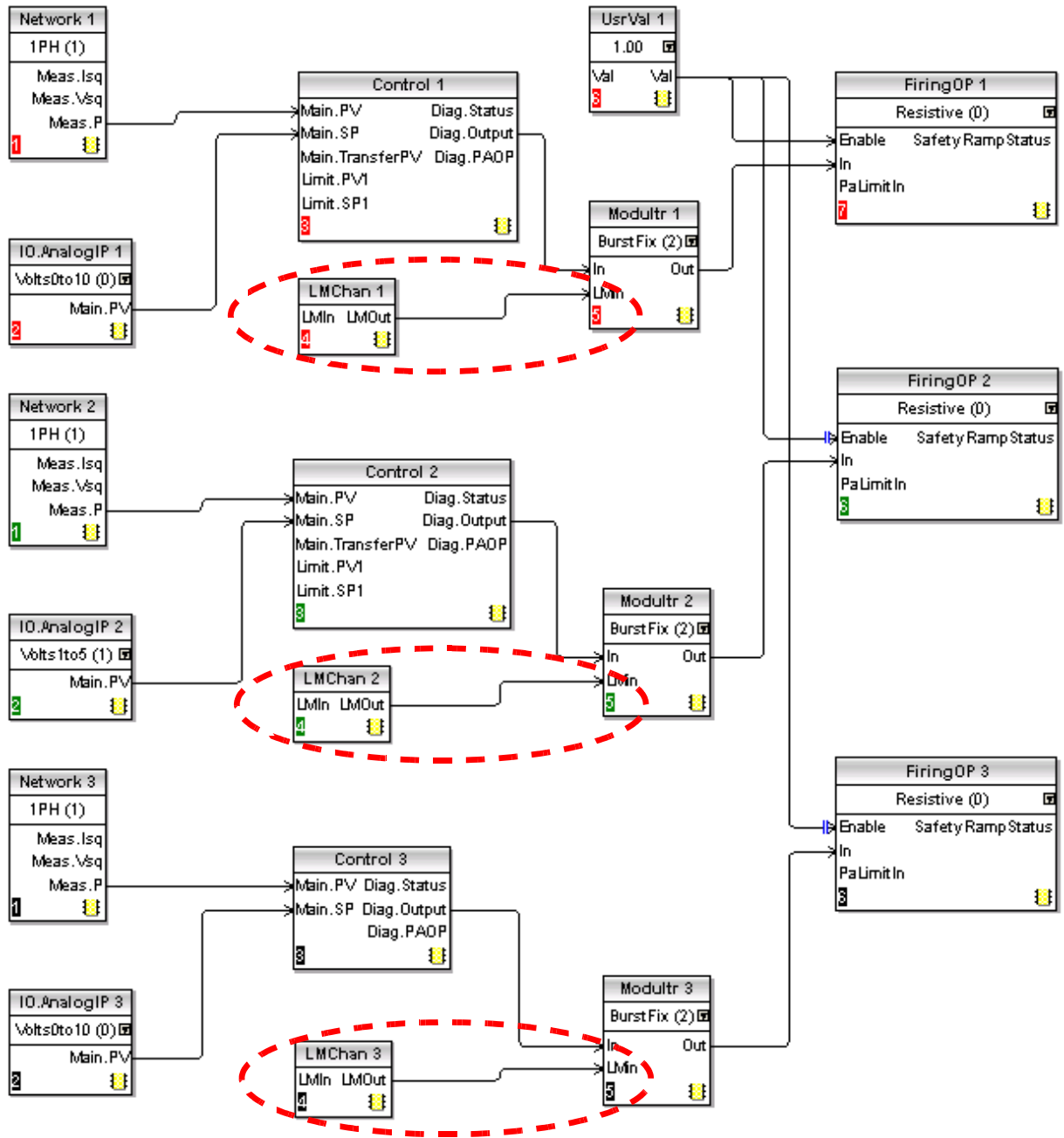

Figure 9.5.1b LMChan blocks

9 5 1 iTOOLS GRAPHICAL WIRING (Cont.)

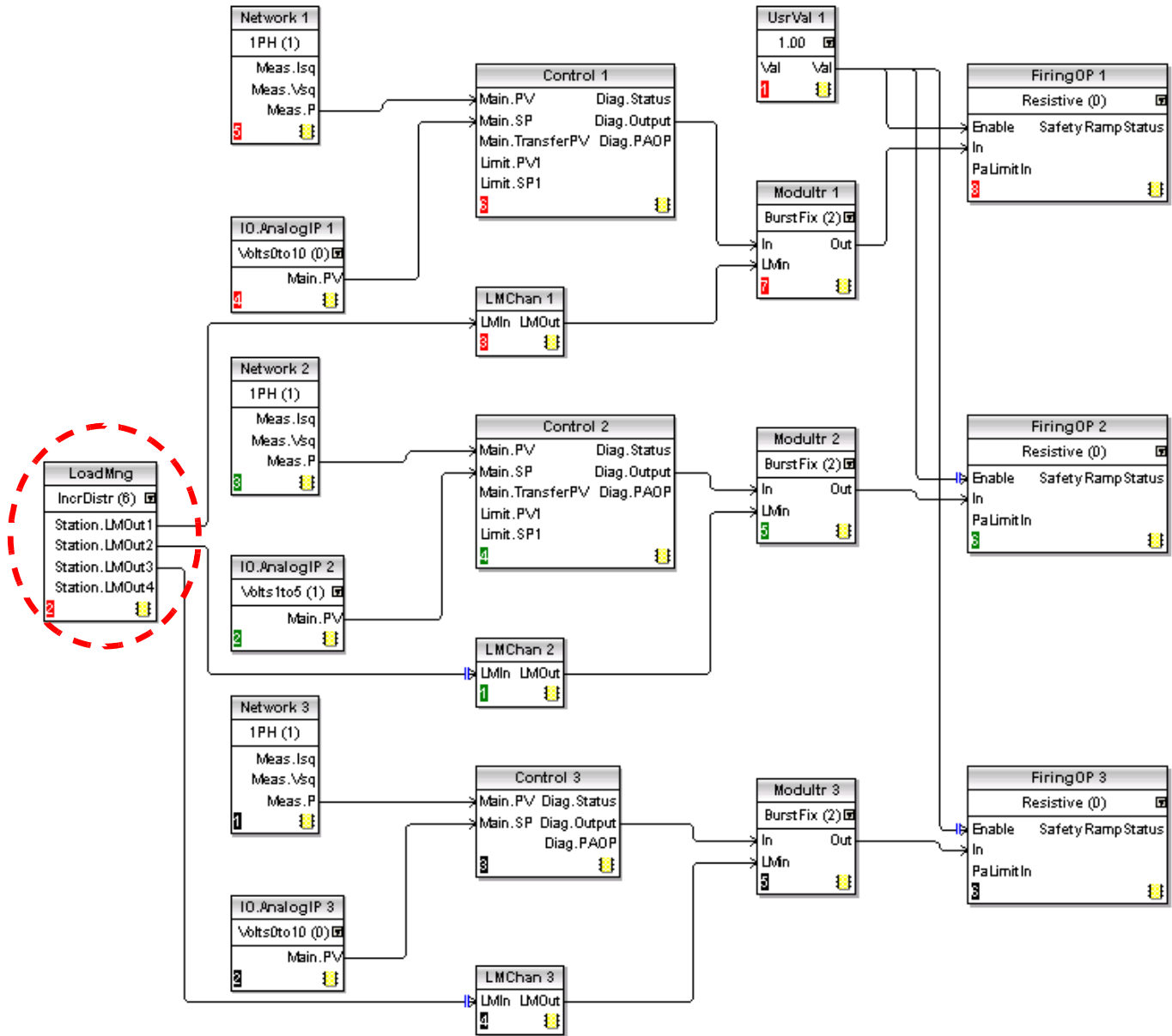

Figure 9.5.1c LoadMng blocks

9.5.2 Predictive Load Management function block details

Full details of Load Management parameters are to be found in [sections 6.21](#) and [6.19](#) above.

LM TYPE

Configures the type of Load Management, as load sharing or load sequencing (or off).

Function block location	LoadMng.Main
Parameter name	Type
Accessible	Always
Minimum access level for editing	Config
Type	Enumeration
Values	0: (LMNo). Load Management disabled 1: (Sharing). Load sharing enabled. See section 9.3 2: (IncrT1). Incremental control type 1 (section 9.2.1). 3: (IncrT2). Incremental control type 2 (section 9.2.2). 4: (RotIncr). Rotating incremental control (section 9.2.3). 5: (Distrib). Distributed control (section 9.2.4). 6: (DistIncr). Incremental distributed control (section 9.2.5).

Note: If Type is not 'LMNo' and 'Address' is non-zero, the Master impose its own Type of Load Management on the associated slaves.

PERIOD

This configures the modulation period for the Station. This is used only by the PLM master and is imposed on all slaves. It is recommended that all slaves are configured to have the same modulation period so that should the master lose control, the newly elected master will inherit the period from the previous master. If the period is different, the new master imposes its own period on the network at the next power-cycle.

'Period' may be set in the range of 50 to 1000 mains periods. The accuracy of the power control is related to this value. To increase the accuracy you must increase the period ([section 9.1.2](#)).

Function block location	LoadMng.Main
Parameter name	Period
Accessible	Always
Minimum access level for editing	Config
Type	Uint16
Values	Min = 50; Max = 1000 mains periods

9.5.2 PREDICTIVE LOAD MANAGEMENT FUNCTION BLOCK DETAILS (Cont.)

ADDRESS

Address of the Station on the Network. This must be configured before Predictive Load Management (PLM) will operate. The default on delivery is 0 which means that PLM is inhibited. The address may be set in a range of 1 to 63, the lowest address on the network will negotiate to become the Network Master.

Function block location	LoadMng.Station
Parameter name	Address
Accessible	Always
Minimum access level for editing	Config
Type	Uint8
Values	Min = 1; Max = 63. 0 = PLM disabled for this Station (default).

Ps

The total amount of power allowed on the Network using Load Shedding. Configured by the user in order to restrict the power demanded from the network.

For example the total installed power could be 2.5MW but it is required that the delivered power be restricted to below a tariff band of 2MW. In such a case Ps would be set to 2MW and power would be shed across the network to ensure that the total demand remains below 2MW.

If Ps is set to a value greater than Pmax, Load Shedding is disabled. The default value for this parameter is set to 5MW. For almost applications, this disables the Load Shedding function

Function block location	LoadMng.Network
Parameter name	Ps
Accessible	With Sharing or Distributed Control only.
Minimum access level for editing	Engineer
Type	Float32
Values	0 to 99999 watts

SHEDFACTOR

This defines, for each channel, the threshold at which the reducing factor is applied to the modulator for load shedding.

Function block location	LMChan
Parameter name	ShedFactor
Accessible	With Sharing or Distributed Control only.
Minimum access level for editing	Engineer
Type	Uint8
Values	0 to 100%

9.5.2 PREDICTIVE LOAD MANAGEMENT FUNCTION BLOCK DETAILS (Cont.)

GROUP

This allows the channel to be allocated to a specific group for Incremental Distributed and Rotating Incremental Distributed control types.

Function block location	LMChan
Parameter name	Group
Accessible	With 'Incremental Distributed' and 'Rotating Incremental Distributed'
Minimum access level for editing	Config
Type	Uint8
Values	0 to 7

PZMAX

Total Power installed on the channel (the sum of all the maximum load powers)

Function block location	LMChan
Parameter name	PZMax
Accessible	Always.
Minimum access level for editing	Read only
Type	Float32
Values	Any (Watts)

STATUS

Indicates the current status of the Station.

Function block location	LoadMng.Station
Parameter name	Status
Accessible	Always.
Minimum access level for editing	Read only
Type	Enumeration
Values	0 (Pending). The election of a master is in progress (section 9.6) 1 (IsMaster). This unit (Station) is the Master. 2 (IsSlave). This unit is a Slave. 3 (DuplAddr). This Station has the same address as one or more others. All such Stations are disabled from taking part in Load Management.

Note: If 'Pending' appears permanently, there is a configuration error in the network.

9.5.2 LOAD MANAGEMENT FUNCTION BLOCK DETAILS (Cont.)

NUMCHAN

This parameter indicates how many channels on this Station, are participating in the Load Management process. See also 'TotalChannels', below.

Function block location	LoadMng.Station
Parameter name	NumChan
Accessible	Always
Minimum access level for editing	Read only
Type	Uint8
Values	Min = 1; Max = 4.

Note: It is not necessary that all channels in a Station participate in the Load Management process.

TOTALSTATION

This parameter indicates how many Stations are participating in the Load Management process on this PLM link.

Function block location	LoadMng.Network
Parameter name	TotalStation
Accessible	Always
Minimum access level for editing	Read only
Type	Uint8
Values	Min = 1; Max = 63

TOTALCHANNELS

This shows how many Channels are participating in the Load Management process on this PLM link.

Function block location	LoadMng.Network
Parameter name	TotalChannels
Accessible	Always
Minimum access level for editing	Read only
Type	Uint8
Values	Min = 1; Max = 64.

9.5.2 LOAD MANAGEMENT FUNCTION BLOCK DETAILS (Cont.)

PMAX

Indicates the total amount of power which is installed on the Load Management Network and is currently participating in the Load Management strategy.

Function block location	LoadMng.Network
Parameter name	Pmax
Accessible	Always
Minimum access level for editing	Read only
Type	Float32
Values	No limits (Watts)

PT

Indicates the total amount of power that has been demanded from the network. (The sum of the powers demanded by each channel participating in the Load Management strategy.)

Function block location	LoadMng.Network
Parameter name	Pt
Accessible	Always
Minimum access level for editing	Read only
Type	Float32
Values	No limits (Watts)

PR

Indicates the total amount of power that has actually been delivered through the network. This value could be larger than Ps depending upon the Shed Factors of all channels.

Function block location	LoadMng.Network
Parameter name	Pr
Accessible	Always
Minimum access level for editing	Read only
Type	Float32
Values	No limits (Watts)

EFFICIENCY

Indicates how efficiently Load Management is operating as a percentage value. This (F) is calculated from the equation: $F = (P_{max} - (P_{tMax} - P_{tMin})) / P_{max}$
 where: P_{tMax} = the maximum peak value of total power during the modulation period.
 P_{tMin} = the minimum peak value of total power during the modulation period.

Function block location	LoadMng.Network
Parameter name	Efficiency
Accessible	Always
Minimum access level for editing	Read only
Type	UInt8
Values	0 to 100%

9.5.2 LOAD MANAGEMENT FUNCTION BLOCK DETAILS (Cont.)

MASTER ADDRESS

Address of elected Master on the PLM network. (Normally the lowest address on the PLM link.) If this Station is master, this address is the same as the Station's PLM address, otherwise it is different.

Function block location	LoadMng.Network
Parameter name	MasterAddr
Accessible	Always
Minimum access level for editing	Read only
Type	Uint8
Values	1 to 63

9.6 MASTER ELECTION

This mechanism ensures that the Active Station with the lowest address is elected the Master. The election process can be initiated in any of the circumstances detailed below. During the election process, the Station Status is 'Pending'.

As soon a Station has been recognized as Master, its Status changes to 'IsMaster'. As soon a Station has been recognized as Slave, its Status changes to 'IsSlave'.

9.6.1 Master Election triggers

1. The election process starts at Initialisation Time and continues until all Stations have found the Master.
2. The election process is initiated if a Station has not received a firing demand for 100ms or more.
3. It is assumed that, if a Master has lost control, it will be re-initialised before being re-inserted into the Network, automatically activating the Master election process.
4. A new Station inserted into the System automatically triggers the Master election.

Notes:

1. The Election mechanism is asynchronous and may be triggered at any time.
 2. During the Election mechanism, Duplicate Address detection is performed. If an address is recognised as duplicate, the Status of the Station changes to 'DupplAddr'.
-

9.7 ALARM INDICATION

PROVERPS

Indication Alarm: Pr over Ps:

This tells the user that the real Power Pr is greater than the requested 'shed power' Ps. This is the case where a shed factor has been applied to one or more channels. Alternatively, the alarm may be caused by the false calibration of one or more channels.

This parameter appears only at the Master Station.

9.8 TROUBLE SHOOTING

9.8.1 Wrong Station status

DUPLICATE LM ADDRESS

One or more Stations have the same PLM address. These Stations are excluded from the PLM process.

Note: Zero is not a valid PLM address. When the PLM address is set to zero, the Station is excluded from the PLM process.

STATION STATUS PERMANENTLY 'PENDING'

PLM Address is set to 0

Hardware wiring error. Ensure that all 'High' pins are correctly daisy chained and that all 'Low' pins are correctly daisy-chained. If there is a break, it is likely that two or more masters will be elected and be working in opposition with one another.

PLM option board not fitted correctly

STATION TYPE MISMATCH

There is nothing to prevent single-phase and three-phase units being mixed. This should be avoided by grouping the single-phase units on one PLM Network, and the three-phase units on another.

10 ALARMS

10.1 SYSTEM ALARMS

System alarms are considered to be 'Major Events' which prevent proper operation of the system, and the relevant module is placed in standby mode. In some configurations (e.g. four × single-phase) it is possible that a system alarm generated in one power module will set only that module into standby mode, and the other three phases will continue as normal.

The following subsections describe each of the possible system alarms.

10.1.1 Missing mains

Supply power is missing from the relevant power module. If one or more phase out of two or three phase systems are missing, the system stops firing altogether, in order to avoid unbalanced firing. The alarm trigger depends on the type of load coupling.

10.1.2 Thyristor short circuit

A thyristor short circuit leads to current flow even when not firing.

10.1.3 Thyristor open circuit

This fault means that no current flow occurs, even when the thyristor(s) should be firing. The fault is detected by measuring the load voltage, so the fault is not detected if the remote sensing option is fitted.

10.1.4 Fuse blown

High speed fuses are fitted in series with the thyristors in order to protect them.

10.1.5 Over temperature

The thyristor heat sink temperature is measured and if it is considered to be too high for the current application, the over temperature alarm is set and firing is inhibited. Hysteresis is built in to the measurement system to ensure that the heat sink is allowed to cool properly before firing can re-commence.

10.1.6 Network dips

This detects a reduction in supply voltage, and if this reduction exceeds a configurable measured value (VdipsThreshold), firing will be inhibited until the supply voltage returns to a suitable value. VdipsThreshold represents a percentage change in supply voltage between successive half cycles, and can be defined by the user in the Network.Setup menu, as described in [section 6.20.2](#).

10.1.7 Mains frequency fault

Triggered if the supply voltage frequency strays out of the range 47 to 63 Hz, or if the mains frequency changes, for one cycle to the next, by more than 0.18% of base frequency, or by more than 0.9% of the frequency measured last cycle. Firing stops until the supply frequency returns to a satisfactory state.

10.1.8 Power board 24V fail

The 24 Volt supply rail in the power module has failed. The power module stops firing immediately, and does not restart until the fault is rectified.

10.2 PROCESS ALARMS

Process Alarms are related to the application and can be configured either to stop the power module firing (Standby Mode) or to allow operation to continue. Process alarms can also be configured to be latched and if so, they have to be acknowledged before the alarm is considered to be non-active. Alarms cannot be acknowledged until the trigger source has returned to a non-active state.

10.2.1 Total Load Failure (TLF)

No load is connected to one or more power controllers.

The detection is based on RMS load current and RMS load voltage of the last mains half cycle. In case of total load failure, a load voltage is measured even though load current is equal or close to zero. This method might not indicate the failed phase accurately in all load configurations (e.g. closed delta configuration for 3 phase load).

10.2.2 Output short circuit

Firing is stopped if a short circuit is detected in the output circuit.

10.2.3 Chop Off

Triggered by one of two user configurable parameters viz: ChopOff1 Threshold and ChopOff2 Threshold (to be found in the Network.setup area of configuration ([section 6.20.2](#))).

'ChopOff1 Threshold' triggers the chop off alarm when the load current meets or exceeds the threshold for more than 5 seconds. Firing stops, and will not re-start until the alarm is acknowledged. The threshold can be set to any value between 100% and 150% of the nominal load current.

'ChopOff2 Threshold' triggers the chop-off alarm if the load current meets or exceeds the ChopOff1 threshold more than 'Number Chop Off' times in 'Window Chop Off' seconds, where 'Number Chop Off' is configurable between 1 and 16, and 'Window Chop Off' can take values between 1 and 65535 seconds (both values inclusive).

Firing stops in the relevant power module, each time the threshold is met or exceeded. Firing restarts after 100ms providing that the threshold has not been exceeded the specified number of times within the specified number of seconds. Otherwise, firing remains disabled until the alarm is acknowledged.

Note: for two- or three-phase systems the over-current measurements relate to the maximum current in any phase, regardless of which phase may be at fault.

10.2.4 Mains Voltage Fault

Two thresholds 'OverVoltThreshold' and 'UnderVoltThreshold' can be configured as a percentage of VLineNominal. Both parameters are to be found in the Network.Setup area of configuration ([section 6.20.2](#)).

The threshold check of each line voltage is implemented in the corresponding network task of the power controller. This fault is indicated within 1 mains cycle period.

Note: This Alarm is returned FALSE if the MissingMains Alarm is set on this phase.

10.2.5 Temperature pre-Alarm

This function acts as a warning which becomes active when unexpectedly high operational temperatures are reached. The warning becomes active before unit operation stops.

HeatsinkPreTemp threshold is configured (between 30°C and 107°C) and if this value is exceeded by the heat sink in any Power module, the alarm is triggered. A hysteresis of 2°C is applied to avoid fast toggling. The parameter is to be found in Network.Setup, as described in [section 6.20.2](#).

10.2.6 Partial Load Failure (PLF)

See also 'PARTIAL LOAD FAILURE CALCULATIONS' in [section 6.20.2](#).

This alarm detects a static increase in load impedance by comparing the reference load impedance (as configured by the user) with the actual measured load impedance over a mains cycle (for phase angle firing) and over the burst period (for burst and logic firing).

The sensitivity of the partial load failure measurement can be set to any value between 2 to 6 inclusive, where an entry of 2, for example, means that one half of the elements (or more) must be open circuit in order to trigger the alarm; an entry of 3 means that one third of the elements (or more) must be open circuit in order to trigger the alarm, and so on down to one sixth. All elements must have identical characteristics and identical impedance values and must be connected in parallel).

The relevant parameters (PLFAdjustReq, and PLFSensitivity) are both to be found in Network.Setup, as described in [section 6.20.2](#).

For three-phase loads, the impedance reference can be set only if the load is balanced.

Note: This Alarm is returned FALSE if the TLF (Total Load Failure) Alarm is set on this phase.

10.2.7 Partial Load Unbalance (PLU)

This alarm is applicable only to three-phase load configurations and indicates when the difference between highest and lowest current value reaches a threshold (PLUthreshold) configurable between 5% and 50% of the highest load current. PLUthreshold appears in Network.Setup, as described in [section 6.20.2](#).

10.3 INDICATION ALARMS

Indication Alarms signal events for operator action if required. Indication alarms cannot be configured to stop power module firing, but they may be latched if required, and if latched, they must be acknowledged for the Signalling Status to return to the normal (non-alarm) state.

10.3.1 Process Value Transfer active

Indicates when a transfer control mode (e.g. $V^2 \ll P \ll I^2$ or $V^2 \ll I^2$) is active.

10.3.2 Limitation active

Indicates when the internal firing control loop limits the firing output (I^2 or V^2) (in order not to exceed the adjusted maximum value)

10.3.3 Load Over-Current

Indicates when a configurable RMS load current threshold (Overlthreshold) is reached or exceeded. The parameter is found in the Network.Setup area of configuration ([section 6.20.2](#)) and is configurable as 10% to 400% of Nominal Current.

10.3.4 Over Load Shedding (Ps over Pr) alarm

Applies only to units fitted with the Load Management option ([section 9](#)).

Load Shedding reduces the global power demand P_t to a given level P_s . Load Shedding and Load Sharing may be applied simultaneously if required.

P_s is the reduced Power; P_t is the total demanded Power. If $P_s \geq P_t$, no reduction is applied. If $P_s < P_t$, each Duty Cycle is reduced by multiplying it by a reduction factor ($r = P_s/P_t$):

For some applications, the Power Demand can not be reduced for particular channels, so each load can be allocated a 'Shed factor' during configuration.

The Reduction coefficient (r) is recalculated for each Channel, such that if $s_i > r$ then $r_i = s_i$, but if $s_i \leq r$, then $r_i = r$. Thus if $s_i = 100\%$ the reducing coefficient is never applied; if $s_i = 0\%$ the reducing coefficient r is always applied as it is.

Thus, the consumed Power is not P_s as requested, but P_r where $P_s \leq P_r \leq P_t$. The alarm P_s over P_t becomes active when $P_r \geq P_s$, to alert the user to the fact that the actual power is greater than the shed power requested.

Note: This alarm appears only at the Load Management master station.

11 TECHNICAL SPECIFICATION

STANDARDS: The product is designed and produced to comply with:

- EN60947-4-3:2000 + EN60947-4-3:2000/A1:2006 + EN60947-4-3:2000/A2:2011
Low-voltage switchgear and controlgear – Part 4-3: Contactors and motor-starters – AC semiconductor controllers and contactors for non-motor loads
(Identical to IEC 60947-4-3:1999 + IEC 60947-4-3/A1:2006 + IEC 60947-4-3/A2:2011)
Declaration of conformity available on request.
- United States Standard UL508 17th Edition, Part VIII **for versions rated up to 600V.**
- Canadian National Standard C22.2 No. 14- 10 **for versions rated up to 600V.**

INSTALLATION CATEGORIES

	Installation Category	Rated impulse withstand voltage (Uimp)	Rated insulation voltage
Communications	II	0.5kV	50V
Standard IO	II	0.5kV	50V
Driver module power	II	2.5kV	230V
Relays	III	4kV	230V
Power Modules (up to 600V)	III	6kV	600V
Power Modules (690V)	II	6kV	690V
Auxiliary (Fan) supply	II	2.5kV	230V

POWER (at 40°C)

CAUTION

Although the driver module supply voltage range is 85 to 265V ac, the fans (if any) fitted to the power (thyristor) modules are specified for use at one of 115V ac or 230V ac as specified at time of order. Before plugging the fan harness into the driver module, ensure that the utility supply voltage is suitable for the fan(s). Otherwise, fan life may be shortened or the cooling effect may not be sufficient, either case presenting a possible hazard to the equipment or to the operator.

Driver Module

Voltage range: 100 to 240 V ac (+10% - 15%)
 Frequency range: 47 to 63 Hz
 Power requirement: 60W + Power Module fans (15W each for 400/500/630A power modules; 10W each for 160A/250A modules).

Installation Category

Installation category II (category III for relays)

Power Module

Number of modules: Up to four identical units per Driver Module.
 Voltage range: 100 to 600 V ac (+10% - 15%) (CE and UL units) or 100 to 690 V ac (+10% - 15%) (CE units only), as specified at time of order.
 Frequency range: 47 to 63 Hz
 Nominal current: 16 to 630 A depending on power module.
 Power dissipation: 1.3W per Amp, per phase.

Cooling

Up to and including 100A: Natural convection
 Above 100A: Fan cooling. Fans are connected in parallel to driver module connector (figure 2.2.1a).
 Fan supply voltage: 115 or 230V ac, as specified at time of order (see 'Caution' above).
 Fan power requirement: 10 W for 160A/250A modules; 15W for 400A, 500 and 630A modules.

Protection

Thyristor drive: RC circuits and high-speed fuses.

Pollution degree

Pollution degree 2

Installation category

Power network: Installation category III up to 600V (CE and UL units) ;
 Installation category II up to 690V (CE units only).

Utilization categories

Auxiliary (fan) supply: Installation category II assuming nominal phase voltage with respect to earth is ≤ 300V rms
 AC51: Non-inductive or slightly inductive loads, resistance furnaces
 AC56a: Switching of transformers.

Overload conditions

AC51: 1 x le continuous

Rated Duty

Uninterrupted duty / continuous operation

Form designation

Form 4 (Semiconductor controller)

Rated short-circuit conditional current:

See paragraph 12.3 for details

CE 92kA all modules except:98kA for 500A modules;105kA for 630A modules.
 690 Volts Maximum; coordination type 1.

UL UL SCCR Rated: 100kA RMS symmetrical amperes, 600 Volts ac Maximum coordination type 1
 ePower units do not incorporate branch-circuit protection. It is the user's responsibility to incorporate branch-circuit protection upstream of the ePower unit. The installation must comply in its entirety with all applicable local safety and emissions regulations.

Load Types

The above branch-circuit protection is necessary in order to meet NEC requirements.
 Single or multiphase control of resistive loads (low/high temperature coefficient and non-aging/aging types) and transformer primaries. Load voltage/current feedback either internal (standard) or external (option for use with transformer secondaries for example).

11 TECHNICAL SPECIFICATION (Cont.)

STANDARD INPUTS/OUTPUTS (SK1)

All figures are with respect to driver module 0V, unless otherwise stated.

Number of inputs/outputs

Number of analogue inputs:	2
Number of analogue outputs:	1
Number of digital inputs/outputs:	2 (each configurable as an input or an output).
10V (Potentiometer) supply:	1

Update rate: Twice the mains frequency applied to power module 1. Defaults to 83.2 Hz (12 ms) if no power applied to power module 1 or if supply frequency lies outside the range 47 to 63 Hz.)

Termination: Removable 10-way connector. (5.08 mm. pitch)

ANALOGUE INPUTS

	Performance:	See tables 11.a and 11.b.
	Input types:	Each input is configurable as one of: 0 to 10V, 1 to 5V, 2 to 10V, 0 to 5V, 0 to 20mA, 4 to 20 mA.
Absolute maxima	+ terminal:	$\pm 16V$ or $\pm 40mA$
	- terminal:	$\pm 1.5V$ or $\pm 300mA$

ANALOGUE OUTPUTS

	Performance:	See tables 11c and 11d.
	Output types:	Each output is configurable as one of: 0 to 10V, 1 to 5 V, 2 to 10V, 0 to 5V, 0 to 20mA, 4 to 20 mA.
Absolute maxima	+ terminal:	(-0.7V or -300mA) or (+16V or + 40mA)
	0V terminal:	$\pm 2A$

10V (POTENTIOMETER) SUPPLY

	Output voltage:	$10.3V \pm 0.3V @ 5.5mA$
	Short circuit o/p current:	15mA max.
	Ambient temperature drift:	$\pm 0.012\%/^{\circ}C$ (typ); $\pm 0.04\%/^{\circ}C$ (max.)
Absolute maxima	Pin 1:	(-0.7V or -300mA) or (+16V or + 40mA)

DIGITAL I/O

	Hardware response time:	100 μ s
Voltage inputs	Active level (high):	$4.4V < V_{in} < 30V$
	Non-active level (low):	$-30V < V_{in} < +2.3V$
	Input impedance:	10k Ω
Contact closure inputs	Source current:	10mA min; 15mA max.
	Open contact (non active) resistance:	$> 500\Omega$
	Closed contact (active) resistance:	$< 150\Omega$
Current source output	Source current:	$9mA < I_{source} < 14mA @ 14V$ $10mA < I_{source} < 15mA @ 0V$ $9mA < I_{source} < 14mA @ -15V$
	Open circuit voltage:	$< 14V$
	Internal pull-down resistance:	10k Ω (to 0 V)
Absolute Maxima	+ terminal:	$\pm 30V$ or $\pm 25mA$
	0V terminal:	$\pm 2A$

Notes:

1. Absolute maximum ratings refer to externally applied signals
2. The 10V potentiometer supply is designed to supply two 5k Ω potentiometers connected in parallel with one another.
3. The maximum current for any 0V terminal is $\pm 2A$.
4. PLC compatibility : Digital inputs are not 100% compliant with IEC 61131-2 (It is recommended that the user check compatibility before use)

11 TECHNICAL SPECIFICATION (Cont.)

Analogue input: Voltage input performance		
Parameter	Typical	Max/Min
Total voltage working input span (note 1)		-0.25V to + 12.5V
Resolution (noise free) (note 2)	13 bits	
Calibration error (notes 3, 4)	<0.25%	<0.5%
Linearity error (note 3)		±0.1%
Ambient temperature error (note 3)		<0.01%/°C
Input resistance (+'ve terminal to 0V)		>140kΩ
Input resistance (-'ve terminal to 0V)	150Ω	
Allowable voltage (-'ve terminal to 0V)		±1V
Series mode rejection of mains interference	46dB	>30dB
Common mode dc rejection	46dB	>40dB
Hardware response time	5ms	
Note 1: w.r.t. to the relevant -'ve input	Note 3: % of effective range (0 to 5V, 0 to 10V)	
Note 2: w.r.t. total working span	Note 4: After warm up. Ambient = 25 °C	

Table 11.a Analogue input specification table (voltage inputs)

Analogue input current input performance		
Parameter	Typical	Max/Min
Total current working input span		-1mA to +25mA
Resolution (noise free) (note 1)	12 bits	
Calibration error (notes 2, 3)	<0.25%	<0.5%
Linearity error (note 2)		±0.1%
Ambient temperature error (note 2)		<0.01%/°C
Input resistance (+'ve to -'ve terminal)	235Ω	
Input resistance (-'ve terminal to 0V)	150Ω	
Allowable voltage (-'ve terminal to 0V)		<±1V
Series mode rejection of mains interference	46dB	>30dB
Common mode dc rejection	46dB	>40dB
Hardware response time	5ms	
Note 1: w.r.t. total working span	Note 3: After warm up. Ambient = 25 °C	
Note 2: % of effective range (0 to 20mA)		

Table 11.b Analogue input specification table (current inputs)

Analogue output: Voltage output performance		
Parameter	Typical	Max/Min
Total voltage working span (within ±20mA (typ.) current span)		-0.5V to +12.5V
Short circuit current		<24mA
Resolution (noise free) (note 1)	12.5 bits	
Calibration error (note 2, note 3)	<0.25%	<0.5%
Linearity error (note 2)		<±0.1%
Ambient temperature error (note 2)		<0.01%/°C
Minimum load resistance		>800Ω
DC output impedance		<2Ω
Hardware response time (10% to 90%)	20ms	<25ms
Note 1: w.r.t. total working span	Note 3: After warm up. Ambient = 25 °C	
Note 2: % of effective range (0 to 5V, 0 to 10V)		

Table 11.c Analogue output specification table (voltage outputs)

11 TECHNICAL SPECIFICATION (Cont.)

Analogue output: Current output performance		
Parameter	Typical	Max/Min
Total current working span (within -0.3V to +12.5V voltage span)		-24mA to +24mA
Open circuit voltage		<16V
Resolution (noise free) (note 1)	12.5 bits	
Calibration error (note 2, note 3)	<0.25%	<0.5%
Linearity error (note 2)		<±0.1%
Ambient temperature error (note 2)		<0.01%°C
Maximum load resistance		<550Ω
DC output conductance		<1μA/V
Hardware response time (10% to 90%)	20ms	<25ms
Note 1: w.r.t. total working span	Note 3: After warm up. Ambient = 25 °C	
Note 2: % of effective range (0 to 20mA)		

Table 11.d Analogue output specification table (current outputs)

RELAY SPECIFICATION

Contact life	Resistive loads:	100,000 operations (de-rate with inductive loads as per figure).
High power use	Current:	<2A (resistive loads)
	Voltage:	<264V RMS (UL: voltage 250Vac.)
Low power use	Current:	>1mA
	Voltage:	>1V
Contact configuration		Single pole change-over (one set of Common, Normally open and Normally Closed contacts)
Termination	Relay 1 (standard):	3-way connector on underside of Driver Module (figure 2.2.1d)
	Watchdog relay (standard):	3-way connector on underside of Driver Module (figure 2.2.1d)
	Relays two to four (option):	12-way option module connector (figure 2.2.1c)
Installation Category		Installation category III, assuming that nominal phase to earth voltage is ≤ 300V RMS. Isolation between different relays' contacts is double isolation, in accordance with the installation category and phase to earth voltage specified above.
Absolute maximum switching capability		<2A at 240V RMS (resistive loads)

Note: Normally Closed and Normally open refer to the relay when the coil is not energised.

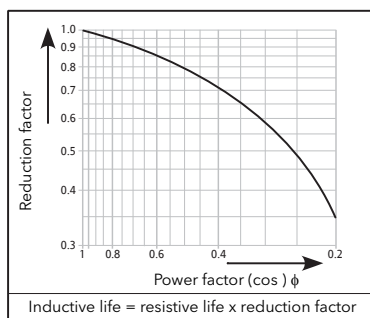

OPTIONAL INPUT/OUTPUT MODULES (SK3, SK4, SK5)

Up to three input/output modules can be fitted, each containing the inputs and outputs detailed below. Unless otherwise stated below, the specification for the optional I/O (including relays) is as given above for the standard I/O.

Termination	Removable 12-way (5.08mm pitch) connector per module.
Number of modules	Up to three
Number of inputs	One analogue input and two digital inputs per module
Number of outputs	One analogue output per module
Number of relays	1 set of common, normally open and normally closed contacts per module.
10V potentiometer supply o/p voltage:	10.0V ± 0.3V at 5.5 mA

11 TECHNICAL SPECIFICATION (Cont.)

MAINS NETWORK MEASUREMENTS

All network measurements are calculated over a full mains cycle, but internally updated every half-cycle. For this reason, power control, current limits and alarms all run at the mains half-cycle rate. The calculations are based on waveform samples taken at a rate of 20kHz. Measurements on each phase are synchronised to its own phase and if the line voltage cannot be detected, the measurements stop for that phase. It should be noted that, depending on the configuration, the phase voltage referred to is one of:

- the line voltage referenced to neutral in four star,
- the line voltage referenced to neutral or another phase for single phase or
- the line voltage referenced to the phase applied to the next adjacent power module for three phase star or delta configurations.

The parameters below are directly derived from measurements for each phase.

Accuracy (20 to 25°C)

Line frequency (F):	±0.02Hz
Line RMS voltage (Vline):	±0.5% of Nominal Vline.
Load RMS voltage (V):	±0.5% of Nominal V for voltage readings >1% of Nominal V. Unspecified for readings lower than 1%Vnom.
Thyristor RMS current (I _{RMS}):	±0.5% of Nominal I _{RMS} for current readings > 3.3% of Nominal I _{RMS} . Unspecified for readings = 3.3% Nominal I _{RMS} (see note).
Load RMS voltage squared (Vsqr):	±1% of (Nominal V) ²
Thyristor RMS current squared (Isqr):	±1% of (Nominal I) ²
True load power (P):	±1% of (Nominal V) × (Nominal I)
Frequency resolution	0.1 Hz
Measurement resolution	11 bits of Nominal value (noise free)
Measurement drift with ambient temp.	<0.02% of reading / °C

Further parameters (S, PF, Q, Z, Iavg, IsqBurst, IsqMax, Vavg, Vsqr Burst, VsqrMax and PBurst) are derived from the above, for each network (if relevant). See [section 6.20.1](#) (Meas submenu) for further details.

Note: For external current feedback, the above specification does not include errors associated with external current transformers.

EXTERNAL CURRENT TRANSFORMER

Ratio: Chosen such that the full scale output from the current transformer is 5 Amps.

COMMUNICATIONS

CC-Link	Protocol:	CC-Link version 1.1
	Connector:	5 way
	Indicators:	RUN and ERR
DeviceNet	Protocol:	DeviceNet
	Connector:	Five way
	Indicators:	Network status and Module status
EtherNet	Type:	10baseT (IEEE801)
	Protocol:	Modbus TCP
	Connector:	RJ45
	Indicators:	Tx activity (green) and communications activity (yellow)
EtherNet/IP	Protocol:	EtherNet/IP
	Connector:	RJ45
	Indicators:	NS (Network status), MS (Module status) and LINK (Link status)
Modbus RTU	Protocol:	Modbus RTU slave
	Transmission standard:	Three-wire EIA485
	Connector:	Twin, parallel-wired RJ45
	Indicators:	Tx activity (green) and Rx activity (yellow)
	Isolation (EN60947-4-3):	Installation category II, Pollution degree 2
	Terminals to ground:	50V RMS or dc to ground (double isolation).
Profibus	Protocol:	Profibus DPV1
	Connector:	9 way D-type
	Indicators:	Mode and Status.

12 MAINTENANCE

12.1 SAFETY

WARNING

BRANCH-CIRCUIT PROTECTION AND SAFETY OVERLOAD PROTECTION

This product does not contain any branch-circuit protection or internal safety overload protection. It is the responsibility of the user to add branch-circuit protection upstream of the unit. It is also the responsibility of the user to provide external or remote safety overload protection to the end installation. Such branch-circuit and safety overload protection must comply with applicable local regulations.

UL: The abovementioned branch-circuit protection is necessary for compliance with National Electric Code (NEC) requirements.

WARNINGS

1. The manufacturer shall not be held responsible for any damage, injury, losses or expenses caused by inappropriate use of the product or by failure to comply with the instructions in this manual. It is the responsibility of the user to check, before commissioning the unit, that all nominal characteristics correspond to the conditions under which it is to be installed and used.
 2. The product must be commissioned and maintained by suitably qualified personnel, authorized to work in an industrial low voltage environment.
 3. Voltage of over 690V RMS may exist in and around the units, even when they are not 'running'. Ensure that all sources of hazardous voltages are isolated from the units before carrying out any work on the units.
 4. The heat sink becomes hot whilst the unit is running, and it can take up to 15 minutes to cool after the unit is shut down. Touching the heat sink, even briefly, must be avoided whilst the unit is operating.
-

12.2 PREVENTIVE MAINTENANCE

Please read the warnings above, before attempting to carry out any work on the unit(s).

1. Every six months check that all power and protective earth cable connections are correctly tightened ([section 2.2](#)). This check should include the safety earth connections to the cabinet.
2. Every six months, check the condition of the ribbon cable between the Driver Module and the adjacent Power module, and of the ribbon cables between Power Modules (if more than one fitted). If damage (e.g. chafing or scratching) is evident, the damaged ribbon cable must be replaced in order to maintain proper protection against damage due to electrostatic discharge.
3. To maintain maximum cooling efficiency, the Power Module heat-sink must be cleaned regularly. Periodicity depends on the local environment, but should not exceed six months.
4. To maintain maximum cooling efficiency, the Power Module fan grilles must be cleaned regularly. Periodicity depends on the local environment, but should not exceed six months.

Note: the thyristor heat sink is the metal part of the Power module casing.

12.3 THYRISTOR PROTECTION FUSES

The thyristors in the Power modules are protected against excess currents by high-speed fuses (supplemental fuse) within the power modules.

According to the CE and UL certifications, high speed fuses (supplemental fuse) are mandatory for the protection of the EPower controller against short circuit. See table 12.3 for details

U.L. : With the high speed fuses (supplemental fuse) as described in the table 12.3 below, EPower is suitable for use on a circuit capable of delivering not more than 100kA RMS symmetrical amperes, 600 Volts ac Maximum. (Coordination Type 1)

CE : With the high speed fuses (supplemental fuse) as described in the table 12.3 below, EPower is suitable for use on a circuit capable of delivering not more than 92kA all modules except:98kA for 500A modules;105kA for 630A modules ; 690 Volts Maximum. (Coordination Type 1)

WARNING

The internal fuses provide protection for the Power modules against load short circuits, and may not be considered as providing any kind of branch-circuit protection. It is the user's responsibility to provide upstream branch-circuit protection (non high-speed fuses, circuit breakers etc.) to protect the installation.

UL: The abovementioned branch-circuit protection is necessary for compliance with National Electric Code (NEC) requirements.

If opening of either the branch circuit protection or the supplemental fuse (high speed fuse), supply voltages shall be isolated and the EPower unit examined and replaced if damaged.

Power module rating	Part number	Fixing size	Tightening torque
50/100A	CS179139U315	M8	12 Nm (8.9 ft lb)
160A	CS179139U315	M8	12 Nm (8.9 ft lb)
250A	CS179139U350	M8	12 Nm (8.9 ft lb)
400A	CS179439U550	M8	15 Nm (11.1 ft lb)
500A	CS029859U630	M10	15 Nm (11.1 ft lb)
630A	CS029960U900	M12	25Nm (18.5 ft lb)

Table 12.3 Protection fuse details

This page is deliberately left blank

APPENDIX A REMOTE DISPLAY UNIT

A1 INTRODUCTION

This appendix describes the recommended 32h8e remote display unit for the EPower unit.

This instrument is a horizontal 1/8 DIN indicator and alarm unit that performs the dual function of remote display and independent 'policeman' (to disconnect power should an over temperature or other excess process condition occur). The unit is intended for indoor use in a permanent installation, enclosed in an electrical panel. To ensure IP65 and NEMA 4 front sealing against dust and water, the panel should have a non-textured surface.

Communications between the unit and EPower are via RJ45 'Panel comms port' located on the underside of the controller module. The communications standard is 3-wire EIA485, and it uses Modbus protocol.

The display unit comes complete with one relay output (OP1) and one analogue output (OP3).

A1.1 SAFETY AND EMC INFORMATION NOTES

WARNING

The safety and EMC protection can be seriously impaired if the unit is not used in the manner specified. The installer must ensure the safety and EMC of the installation.

WARNING

Live sensors. The remote panel is designed to operate if the temperature sensor is connected directly to an electrical heating element. However, you must ensure that service personnel do not touch connections to these inputs while they are live. With a live sensor, all cables, connectors and switches for connecting the sensor must be mains rated for use in 240Vac CATII.

WARNING

The Remote Panel must not be wired to a three phase supply with an unearthed star connection. Under fault conditions such a supply could rise above 240Vac with respect to ground and the product would not be safe.

CAUTION

Charged capacitors: Before removing an instrument from its sleeve, disconnect the supply and wait at least two minutes to allow capacitors to discharge. Avoid touching the exposed electronics of an instrument when withdrawing it from the sleeve.

1. This instrument is intended for industrial temperature and process control applications within the requirements of the European Directives on Safety and EMC.
2. Safety. This instrument complies with the European Low Voltage Directive 73/23/EEC, by the application of the safety standard EN 61010.
3. Unpacking and storage. If on receipt, the packaging or unit is damaged, do not install but contact your supplier. If being stored before use, protect from humidity and dust in an ambient temperature range of -30°C to +75°C.
4. Always observe all electrostatic precautions before handling the unit.
5. This instrument has no user serviceable parts. Contact your supplier for repair.
6. Isopropyl alcohol may be used to clean labels. Do not use water or water based products. A mild soap solution may be used to clean other exterior surfaces.
7. Electromagnetic compatibility. This instrument conforms with the essential protection requirements of the EMC Directive 89/336/EEC, by the application of a Technical Construction File. It satisfies the general requirements of the industrial environment defined in EN 61326.

A1.1 SAFETY AND EMC INFORMATION (Cont.)



8. Installation Category and Pollution Degree: This unit has been designed to conform to BSEN61010 installation category II and pollution degree 2, defined as follows:
Installation Category II (CAT II). The rated impulse voltage for equipment on nominal 230V supply is 2500V.
Pollution Degree 2. Normally only non conductive pollution occurs. However, a temporary conductivity caused by condensation must be expected.
9. Installation may be carried out only by suitably qualified personnel
10. To prevent hands or metal tools touching parts that may be electrically live, the Remote Panel must be installed in an enclosure.
11. Wiring must comply with all local wiring regulations, i.e. UK, the latest IEE wiring regulations, (BS7671), and USA, NEC Class 1 wiring methods.
12. Do not connect AC supply to low voltage sensor input or low level inputs and outputs.
13. Voltage rating. The maximum continuous voltage applied between any of the following terminals must not exceed 240Vac:
relay output to logic, dc or sensor connections;
any connection to ground.
14. Conductive pollution. Electrically conductive pollution i.e. carbon dust, MUST be excluded from the enclosure in which the Remote Panel is installed. To secure a suitable atmosphere in conditions of conductive pollution, fit an air filter to the air intake of the enclosure. Where condensation is likely, include a thermostatically controlled heater in the enclosure.
15. Grounding of the temperature sensor shield. In some installations it is common practice to replace the temperature sensor while the Remote Panel is still powered up. Under these conditions, as additional protection against electric shock, it is recommended that the temperature sensor shield be grounded. Grounding through the framework of the machine should not be relied on.
16. Over Temperature Protection. To prevent overheating of the process under fault conditions, a separate over-temperature protection unit should be fitted which will isolate the heating circuit. This must have an independent temperature sensor. The 32h8e is intended for this function.

Note: Alarm relays within the unit do not give protection under all failure conditions.

17. To comply with European EMC directive certain installation precautions are necessary:
General guidance. Refer to EMC Installation Guide, Part no. HA025464.
Relay outputs. It may be necessary to fit a suitable filter (depending on load type) to suppress conducted emissions.
Table top installation. If using a standard power socket, compliance with commercial and light industrial emissions standard is usually required. To comply with conducted emissions standard, a suitable mains filter must be installed.

SYMBOLS

Symbols used on the instrument are defined in the table below

	Caution refer to accompanying document
	Equipment protected throughout by DOUBLE ISOLATION

A2 MECHANICAL INSTALLATION

A location should be chosen which is subject to minimum vibrations; the allowable ambient temperature range is 0 to 55°C (32 to 131°F) and the acceptable humidity range is 5 to 95% RH non-condensing.

To remove the indicator from its Sleeve, ease the latching ears outwards and pull the unit forward. When plugging back in ensure that the latching ears click into place (maintains the IP65 sealing).

1. An aperture with dimensions as shown in figure A2 should be made in the panel.
2. If it is not already in place, fit the IP65 sealing gasket behind the front bezel of the unit.
3. From the front of the panel, insert the unit, through the cut-out.
4. Spring the panel retaining clips into place and secure the unit in position by pushing both retaining clips forwards, until they bear on the back of the panel.
5. Peel off the protective cover from the display.

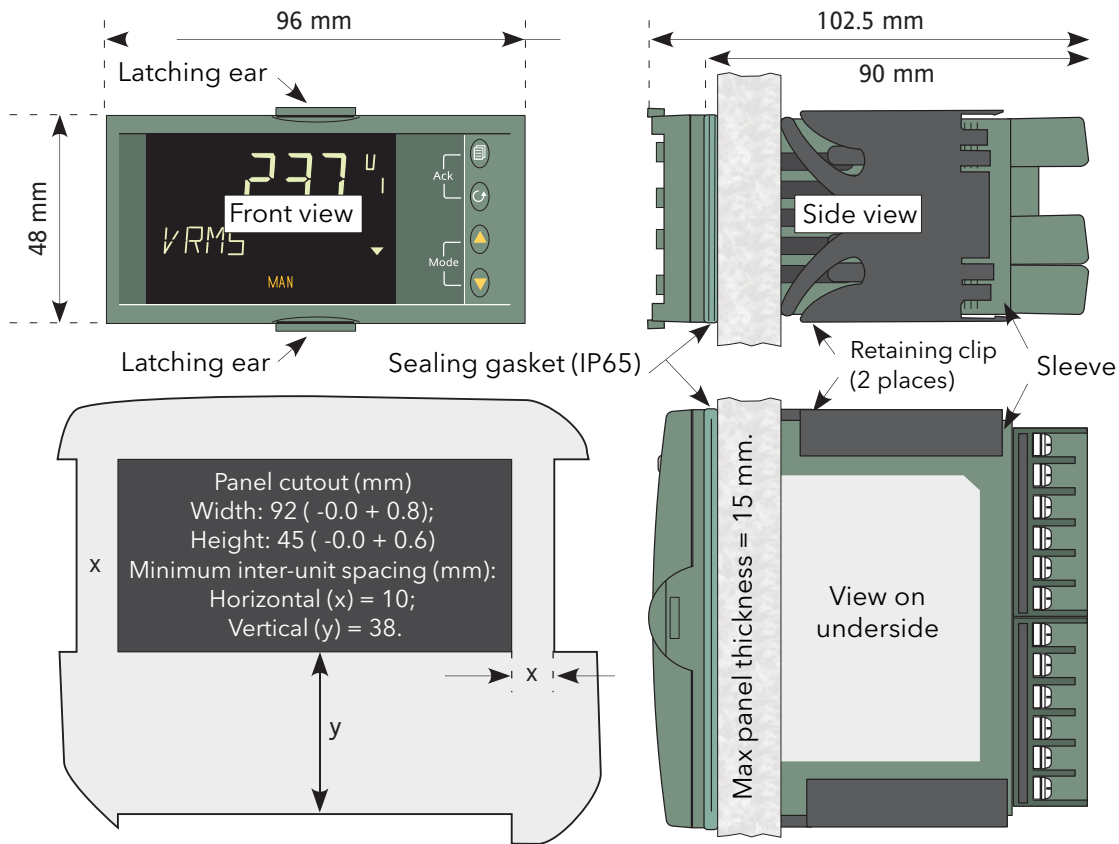

Figure A2 Installation dimensions drawing

A3 ELECTRICAL INSTALLATION

A3.1 PINOUT

Figure A3.1, below shows the rear terminal arrangement.

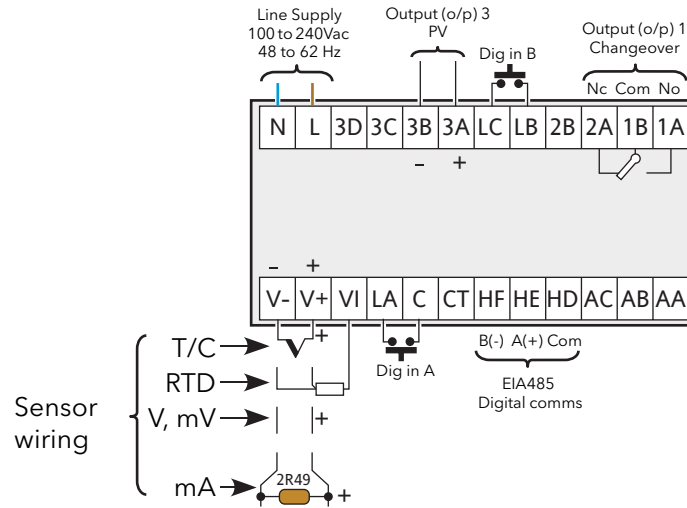

Figure A3.1 Terminal arrangement

A3.2 WIRING

A3.2.1 Termination details

The screw terminals accept wire sizes from 0.5 to 1.5 mm (16 to 22AWG). Hinged insulating covers prevent accidental contact with live wires. The recommended maximum rear terminal screw torque is 0.4Nm.

A3.2.2 Supply voltage

Please read the safety notes in [section A1.1](#) of this manual. Additionally:

1. Only copper conductors may be used.
2. The power supply input is not fuse protected. Fusing must be provided externally by a type T fuse with a 2 Amp, 250V rating.

SUPPLY VOLTAGE RANGE

100 to 240Vac, -15%, +10%, 48 to 62 Hz

A3.2.3 Signal wiring

Notes:

1. Input wires should not be run in proximity with power cables
2. When shielded cable is used, it should be grounded at one point only
3. Any external components (such as Zener barriers) connected between sensor and input terminals may cause errors in measurement due to excessive and/or unbalanced lead resistance and leakage currents.
4. Analogue inputs are not isolated from digital inputs or from logic outputs.

ANALOGUE (MEASURING) INPUTS

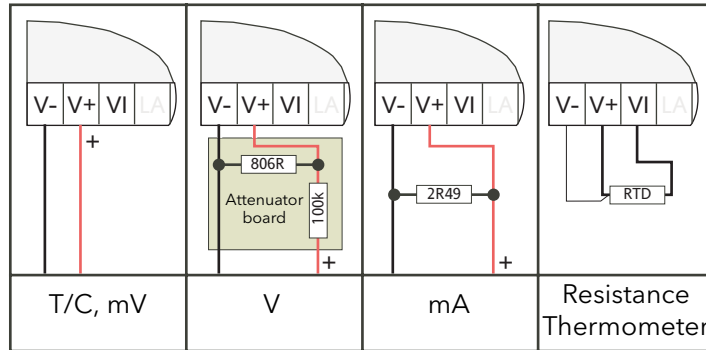

Figure A3.2.3a Input wiring

Notes:

1. For thermocouple inputs, compensation cable suitable for the thermocouple type must be used, preferably shielded.
2. For voltage inputs an attenuator board must be fitted as shown. A suitable board is available from the manufacturer.
3. For resistance temperature detectors, the resistance element is wired across V+ and VI; the lead compensation wire being terminated at V-. The resistance of all three wires must be equal. Line resistances greater than 22 Ohms cause measurement errors.

OUTPUT WIRING

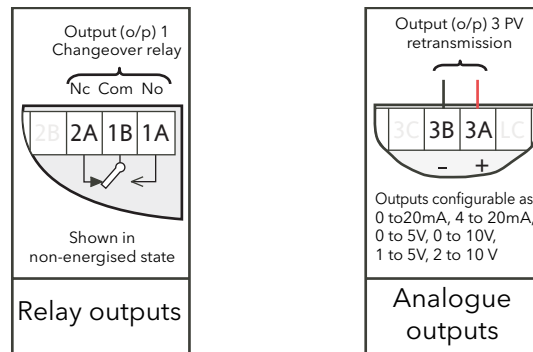

Figure A3.2.3b Output wiring

A3.2.4 Digital communications wiring

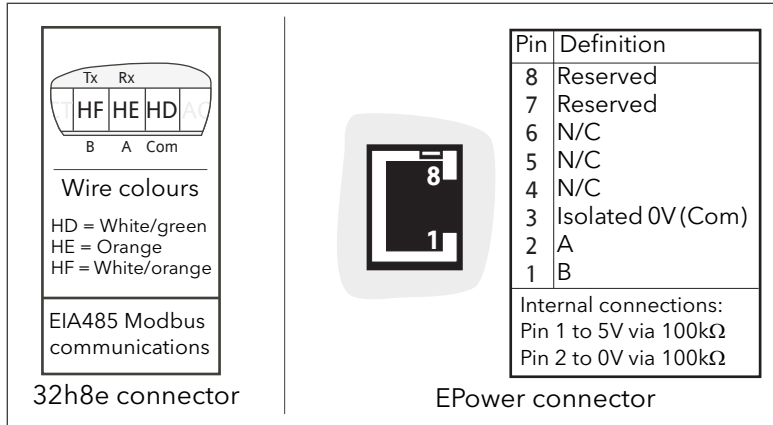

Figure A3.2.4 Digital communications pinouts

A3.3 OVER TEMPERATURE APPLICATION WIRING

Figure A3.3 shows a typical application where the Remote Display Unit is used to trip the main contactor to the EPower units if it detects an over-temperature.

The figure is intended for guidance only, and does not show detailed EPower wiring, this being discussed in depth in [section A2](#) of this manual.

Notes:

1. When switching inductive loads, the 22nF/100 Ohm snubber (supplied with the instrument) should be wired across the relay connections as shown.
2. Snubbers pass 0.6mA at 110V and 1.2mA at 230Vac. This is sometimes sufficient to hold high impedance loads on. Snubbers should not be used in such cases.

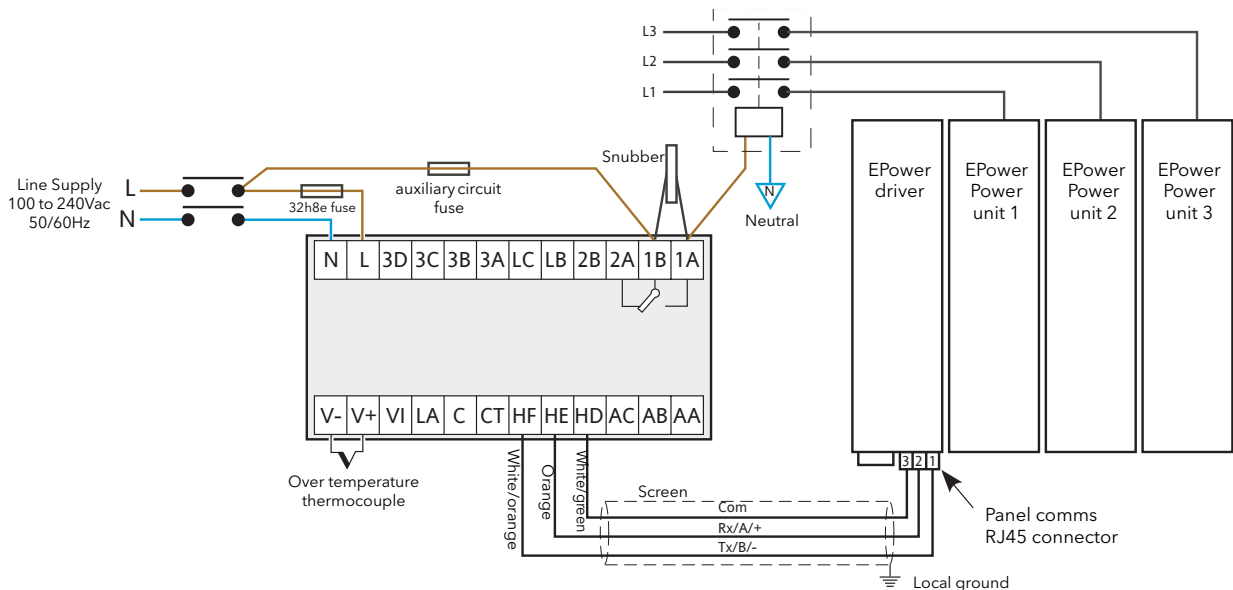

Figure A3.3 Typical wiring

A4 FIRST SWITCH ON

At first switch on, after the start-up sequence, the initial configuration page is displayed.

Note: the following 'quickstart' description applies only to new (not previously configured) instruments. If the instrument has previously been configured (either at the factory or subsequently) the instruments starts up showing the relevant process value.

The initial display shows 'Set1' on the top line, with a coded display below (figure A4) with its first item flashing. The lower line is decoded as shown in table A4a.

The 'mode' (up/down arrows) are used to scroll through the available choices for each item. Once the required value is displayed, the scroll key is used to select the next character for editing. Once all five characters have been edited, further operations of the scroll key call the range high display (allowing the high range value to be edited using the mode keys), then the range low display (allowing the low range value to be edited). A further operation calls the Set2 display, which is decoded in table A4b.

After Set2 parameters have been edited, a further operation of the scroll key invites the user to Exit. Operating the scroll key returns to the Set1 display; operating a mode key to display 'yes' quits the quickstart menu and causes the unit to enter operating mode.



Figure A4 Set 1 display

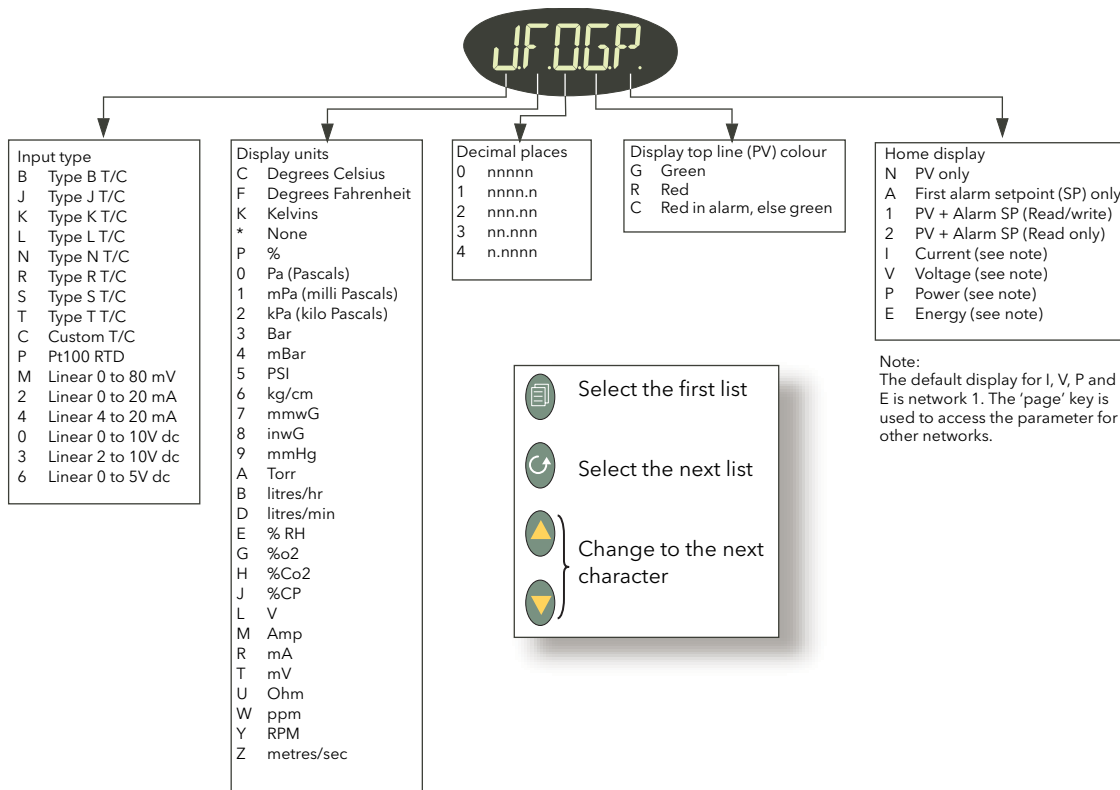

Table A4a Set 1 parameter coding

A4 FIRST SWITCH ON (Cont.)

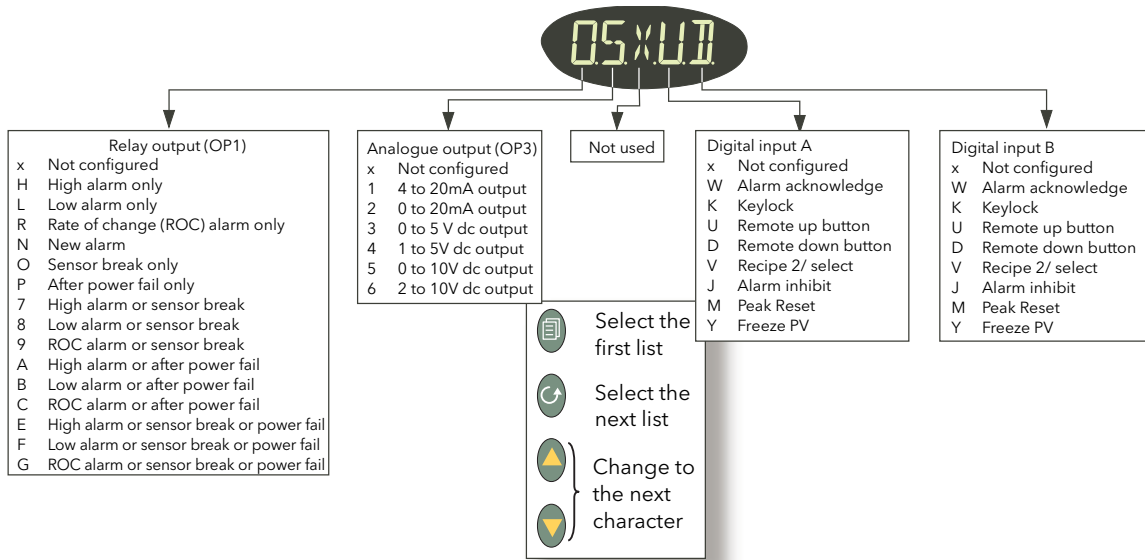

Table A4b Set 2 parameter coding

Notes:

1. In order for the unit to act as an over-temperature 'police officer', the OP1 alarm type should be selected as a high alarm.
2. The relay output automatically operates in fail-safe mode, in that it is de-energised in Alarm. It will thus enter an alarm state when power is removed from the unit.
3. To re-enter quickstart mode,
Remove power from the unit
Keeping the 'Page' key operated continuously, restore power and wait until a password is requested. Release the 'Page' key and use the up/down arrow keys to enter the quickstart password (default = 4).

A5 OPERATING MODE

A5.1 FRONT PANEL LAYOUT

When the instrument starts, or after quitting the quickstart procedure, the Operator level 1 display is entered and the page defined as the 'Home' page in 'Set 1' is displayed (unless there are any errors, in which case the unit displays the relevant error messages). Figure A5.1, below, shows the home page for the case where 'V' has been selected as Home display in 'Set 1'.

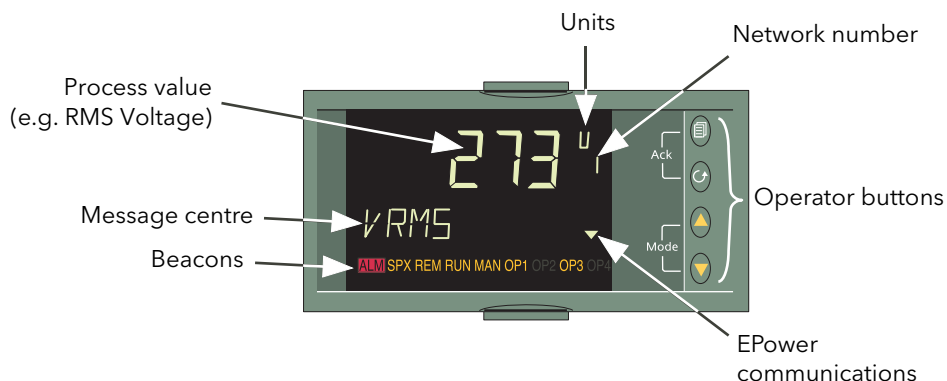







Figure A5.1 Display panel details

A5.1 FRONT PANEL LAYOUT (Cont.)

A5.1.1 Front panel details

Process Variable	Normally shows the value of the selected process variable. Where EPower variables are being displayed, the value for network 1 is displayed by default. Other network values are accessed by using the 'Page' key. If the instrument is in an error state, then an indication of what the error might be is flashed on and off instead (e.g. 'Sbr' is flashed if an input sensor break has been detected). Set1 PV colour allows this part of the display to be selected as permanently green ('G', permanently red ('R'), or normally green but red in error or alarm states ('C').
Units	Displays the units associated with the currently displayed process value.
Network number	For EPower parameters, shows the network for the currently displayed process variable.
Message centre	This displays scrolling event and/or alarm messages (e.g. 'INPUT SENSOR BROKEN')
Beacons	<p>ALM Indicates an active alarm. Flashes if alarm unacknowledged.</p> <p>SPX Alternative setpoint. Not used in this application.</p> <p>REM* Illuminated when 'Remote Setpoint' is selected for this EPower network.</p> <p>RUN Timer or programmer running/held. Not used in this application.</p> <p>MAN* Illuminated when 'Local Setpoint' is selected for this EPower network.</p> <p>OP1 Illuminated if output 1 (relay) is active.</p> <p>OP2 Illuminated if output 2 is active. Not used in this application.</p> <p>OP3 Illuminated if output 3 has been configured to retransmit the process value.</p> <p>OP4 Illuminated if output 4 is active. Not used in this application.</p>
Operator buttons	<p>Four buttons to allow navigation and configuration functions.:</p> <ul style="list-style-type: none">  Page key. Toggles between process variable and summary parameters. Also used (simultaneously with the Scroll key) to acknowledge alarms.  Scroll key. Press to select new parameter. Hold down to scroll through parameters. Also used (simultaneously with the Page key) to acknowledge alarms.  Up Arrow. Used to change (increase) a parameter value.  Down Arrow. Used to change (decrease) a parameter value.
Comms indicator	 If flashing, this arrow head indicates that communications with EPower are active.

* See REM/MAN BEACONS (below) for more details.

A5.1.1 FRONT PANEL DETAILS (Cont.)

REM/MAN BEACONS

Table A5.1.1 summarises the operating characteristics of the 'REM' and 'MAN' beacons which depend on the network with which the currently displayed value is associated, and on which SetProv function blocks are enabled (if any).

Network 1	If no SetProv blocks are enabled, then MAN always illuminated. Otherwise REM/MAN operation depends on SetProv1 'SPselect' parameter.
Network 2	If no SetProv blocks are enabled, then MAN always illuminated. If SetProv.1 and SetProv.2 are enabled, REM/MAN operation depends on SetProv.2 'SPselect' parameter. If SetProv.1 and SetProv.3 are enabled, REM/MAN operation depends on SetProv.3 'SPselect' parameter. If only SetProv.1 enabled: REM/MAN operation depends on SetProv1 'SPselect' parameter.
Network 3	If no SetProv blocks enabled, then MAN always illuminated. If SetProv.1 and SetProv.3 are enabled, REM/MAN operation depends on SetProv.3 'SPselect' parameter. If only SetProv.1 enabled, REM/MAN operation depends on SetProv1 'SPselect' parameter.
Network 4	If no SetProv blocks enabled, then MAN always illuminated. If SetProv.1 and SetProv.4 are enabled, REM/MAN operation depends on SetProv.4 'SPselect' parameter. If only SetProv.1 enabled, REM/MAN operation depends on SetProv1 'SPselect' parameter.

Table A5.1.1 REM/MAN beacon characteristics

A5.2 LEVEL 1 OPERATION

Level 1 operation is entered when Set2 is quit, or after applying power to the instrument (other than at first power-up).

Level 1 operation allows the user to scroll through the various parameters associated with the instrument on a Read-only basis. The parameters which appear depend on the configuration. Figure A5.2a is an example showing the display pages where the home page (set 1) is PV only and the configuration comprises one or more single phase EPower units. Figure A5.2b is an example giving the parameters for a 2x2 leg, three-phase configuration.

A5.2 LEVEL 1 OPERATION (Cont.)

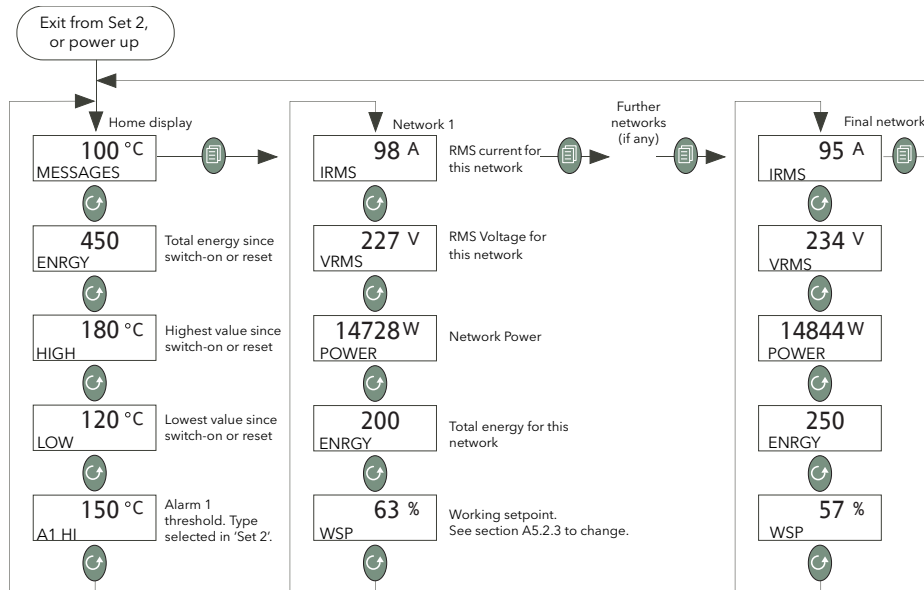

Figure A5.2a Single phase example configuration

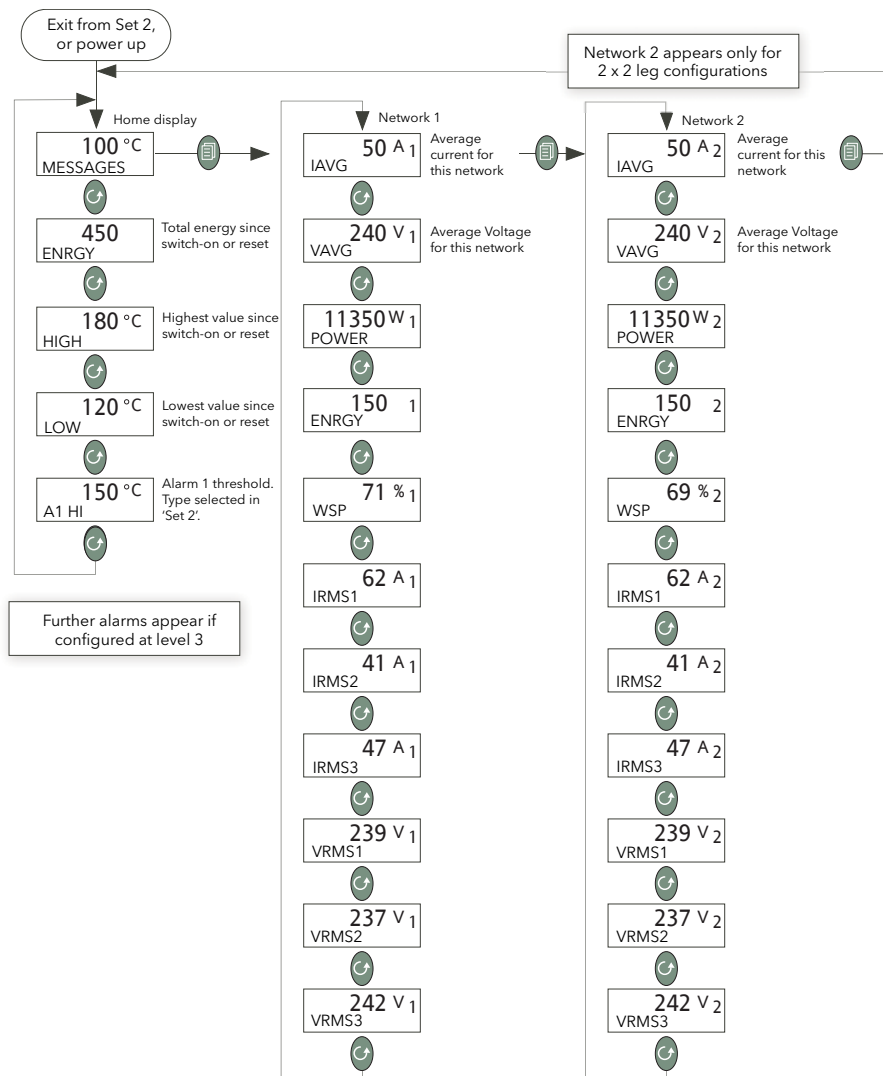

Figure A5.2b Three-phase (2x2leg) example configuration

A5.2 LEVEL 1 OPERATION (Cont.)

A5.2.1 Process Parameters

ENRGY	Energy. Shows the global energy counter in the EPower instrument. This is only available if the Energy Counter feature is enabled in the connected EPower instrument.
HIGH	Peak High. Shows the highest reading that the indicator has recorded since switch on or since reset (Level 2).
LOW	Peak Low. Shows the lowest reading that the indicator has recorded since switch on or since reset (Level 2).
A1 (<i>Type</i>)	Alarm 1 type and setpoint. Indicates the threshold value for alarm 1. 'Type' = 'Hi', 'Lo' or 'ROC' according to configuration (Set 2). This parameter does not appear if it is 'Unconfigured' in Set 2.
An (<i>Type</i>)	('n' = 2, 3 or 4) Further alarm types and threshold values, as configured in level 3 configuration.

A5.2.2 EPower Network summary parameters

IRMS	The RMS value of load current (Amps), for this network.
VRMS	The RMS value of load voltage (Volts) for this network
POWER	Either P or PBurst according to network type. Watts or kilowatts
ENRGY	Energy. Shows the energy for this network. This is only available if the Energy Counter feature is enabled in the connected EPower instrument.
WSP	Working setpoint. WSP is the working setpoint currently being used by the EPower unit and is either the Local setpoint, or the remote setpoint (from an analogue input or via a communications link).
SP	Target setpoint (% or Engineering units) for the network in use. It may be edited via the remote panel either directly setting the Control Setpoint (if EPower's SetProv function block is not enabled) or setting the local setpoint of the SetProv function block (if it is enabled and its SPSelect parameter is set to 'Local'). If the value is greater than 99999, the displayed value is divided by 1000 and shown with suffix 'K' in the format 'nnnn.nK' ('K' = kilo). (E.G. a value of 1000000 would be displayed as '1000.0K').
SPSEL	Setpoint Select. Available only in level 2 and if the associated SetProv function block in EPower is enabled, allowing the user to select between local (LSP) and remote setpoints (rSP).
E.RST	Energy Reset. Available only in level 2 and if the Energy Counter is enabled in EPower. User Energy total can be reset.
IRMS1 (2) (3)	RMS Load current for phase 1 (2) (3). (3-phase networks only)
VRMS1 (2) (3)	RMS Load voltage for phase 1 (2) (3). (3-phase networks only)
I AVG	Average load current (3-phase networks only)
V AVG	Average load voltage (3-phase networks only)

A5.2.3 Setpoint editing from the 32h8E

Operating the up or down arrow key from any of the power summary displays (e.g. IRMS) takes the user to the WSP display. Further operation of the up or down arrow causes the display to switch to 'SP' provided that the unit is operating in Local mode (MAN illuminated) rather than Remote mode (REM illuminated). In Rmote mode, the SP parameter does not appear.

The mode can be changed between local and remote from the SPSEL parameter at level 2, or from the EPower operator interface, iTools or over a comms link.

Once in SP, the up and down arrows are used to edit the setpoint value. Once this is complete, the display times out to the original power summary SP page after a few seconds. Figure A5.2.3 attempts to show this process.

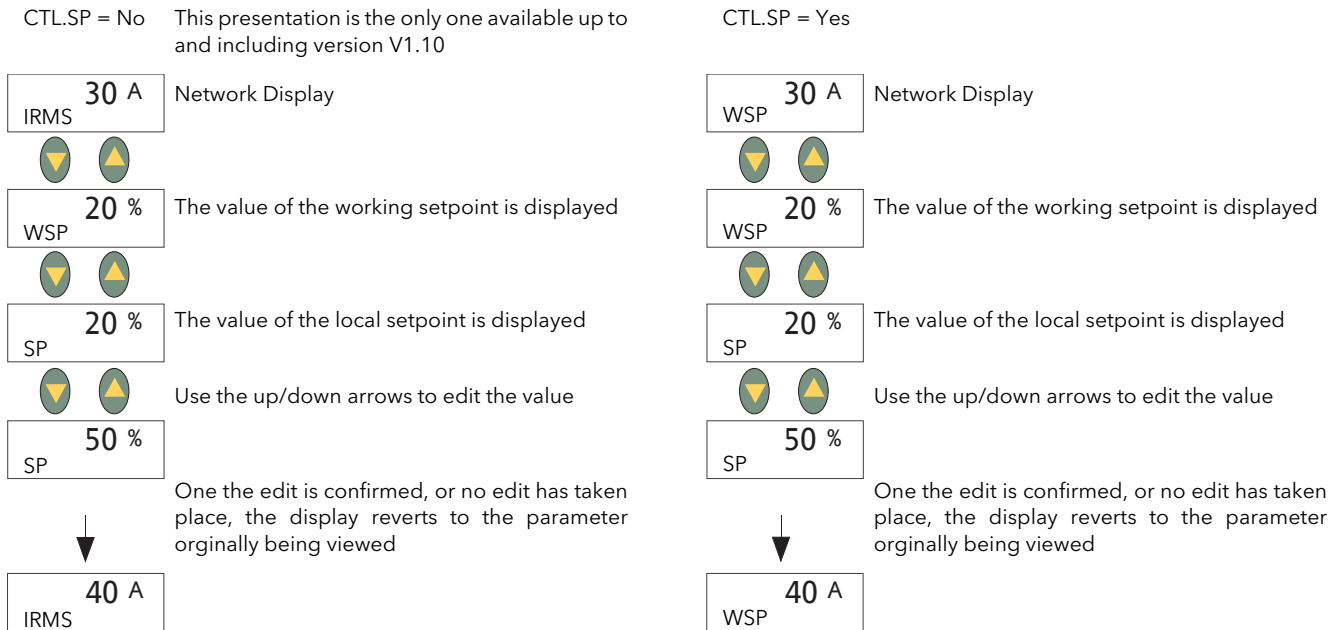

Figure A5.2.3 Setpoint editing

A5.3 LEVEL 2 OPERATION

To switch to level 2 parameters (figure A5.3a):

1. From any display press and hold the page key until the Lev 1 display appears
2. Operate the up or down arrow to display 'Lev 2'
3. After a few seconds, the 'Code' page appears. Use the up arrow key twice to enter the value '2'
4. After a few seconds the display reverts to the home display.

To return to level 1:

1. From any display press and hold the page key until the Lev 2 display appears
2. Operate the up or down arrow to display 'Lev 1'
3. After a few seconds the display reverts to the home display.

The scroll key is used to enter the parameter display from the home display.

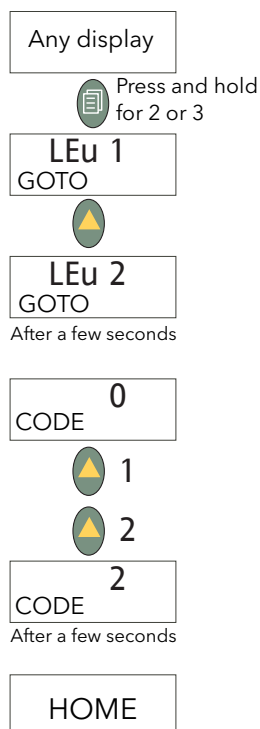

Figure A5.3a Selecting level 2

A5.3.1 Level 2 parameters

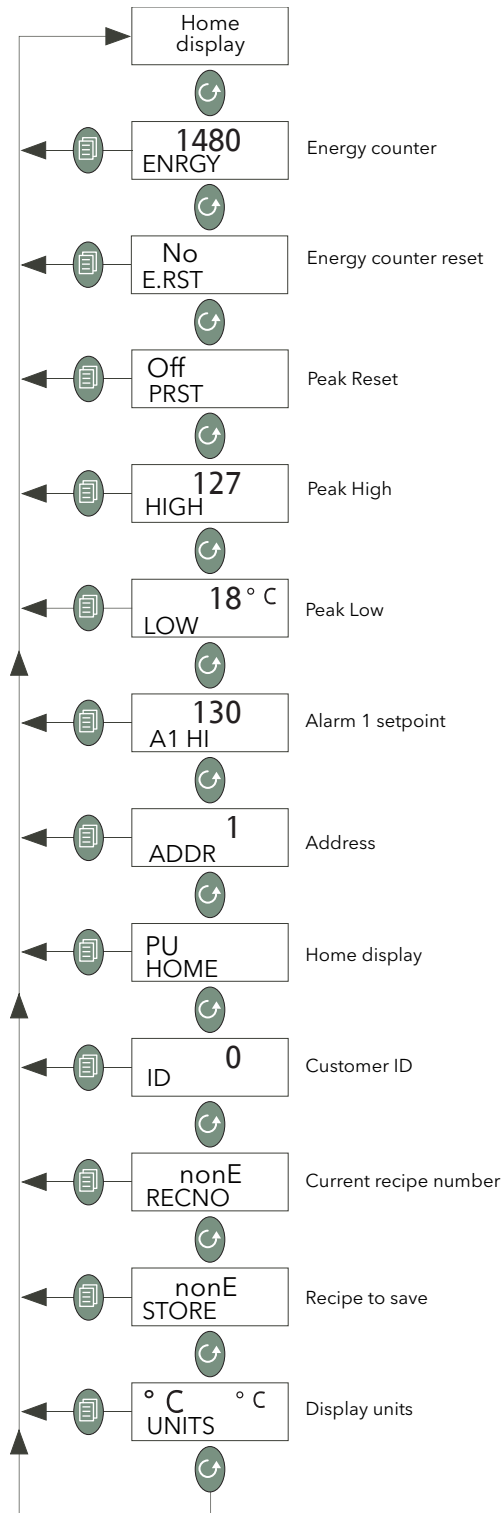

Figure A5.3.1 Level 2 parameter menu

ENRGY

Energy counter. Shows the global energy counter in the EPower instrument. This is only available if the Energy Counter feature is enabled in the connected EPower instrument.

E.RST

Energy Reset. Allows the energy counter to be reset. Only available only if the Energy Counter is enabled in EPower. Set to 'yes' to reset. Automatically returns to 'no'.

A5.4 LEVEL 3 AND CONF LEVEL OPERATION

To switch to level 3 parameters (figure A5.4):

1. From any display press and hold the page key until 'Lev 3' appears ('Lev1' or 'Lev2' appears first - keep holding).
2. If required, operate the up arrow to display 'ConF'
3. In either case, after a few seconds, the 'Code' page appears. Use the up arrow key twice to enter the value '3' (to enter level 3) or '4' (to enter Configuration level).
4. After a few seconds the display reverts to the home display.

To return to lower access levels:

1. From any display press and hold the page key until 'Lev 3' or 'ConF' appears
2. Operate the down arrow one or more times to display the required access level.
3. After a few seconds the display reverts to the home display.

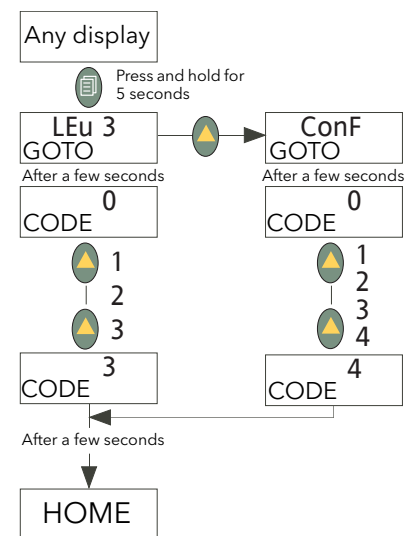

Figure A5.4 Selecting level 3 or Conf

A5.4.1 Level 3/Conf parameters

Most Level 3 and/or Configuration level parameters associated with the remote panel indicator are described in the 3200i Engineering Handbook (HA029006) available from the manufacturer. There are a number of additional parameters associated with the 32h8e, which are described below.

Level 3 access level makes those operating parameters, which are not Read only available to the user. Examples are Input Filter Time Constant, Alarm Delay time, and so on. Level 3 is used, typically, when commissioning the indicator.

Configuration level enables the fundamental characteristics of the indicator to be changed. This includes the quick-start code parameters amongst others.

The menu structures for Level 3 and Configuration levels are identical (see figure A5.4.1a) but there are more parameters available within each 'heading' at Configuration level.

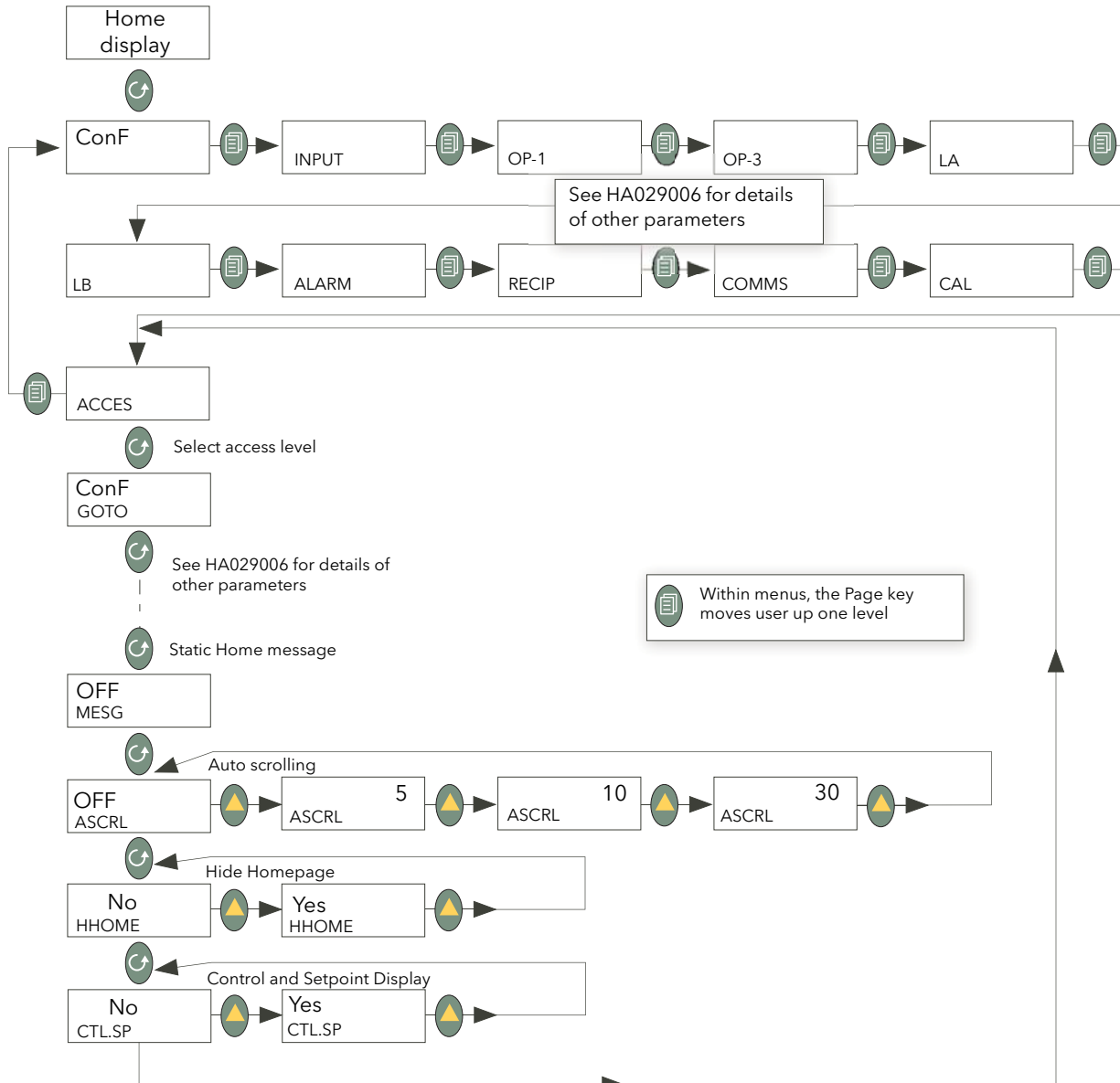

Figure A5.4.1a Level 3 and configuration level menu structure.

- ASCRL Auto scrolling. The up (or down) arrow is used to scroll through the values available, these being 'Off' (No scrolling) or 5, 10 or 30 seconds (where the selected time value specifies the time between scrolls). See 'AUTO SCROLL' below for further details.
- HHOME Hide Homepage. If set to 'Yes', the home page is never displayed, so the associated parameters can never be viewed at lower access levels.
- CTL.SP Control and Setpoint Display. If set to 'Yes' the EPower control parameters (Current, Voltage, or Power) can be viewed, in Operator level, simultaneously with it's associated Setpoint. When displaying an EPower control parameter, the bottom line of the display is used to display the working setpoint. When set to 'No', the bottom line of the display is used to display the parameter name and parameter description (as per other indicator displays). Also see section A5.2.3.

For all other parameters, refer to the 3200i Engineering Handbook (HA029006).

5.4.1 LEVEL 3/CONF PARAMETERS (Cont.)

AUTO SCROLLING

This causes the EPower summary parameters to scroll through continuously, at a frequency defined by the value selected for the ASCRL parameter. The actual order of parameter appearance depends on level of access, and complexity of network.

Note: The 3-phase parameters IRMS1, IRMS2, IRMS3, VRMS1, VRMS2, VRMS3 are not included in autoscrolling sequences.

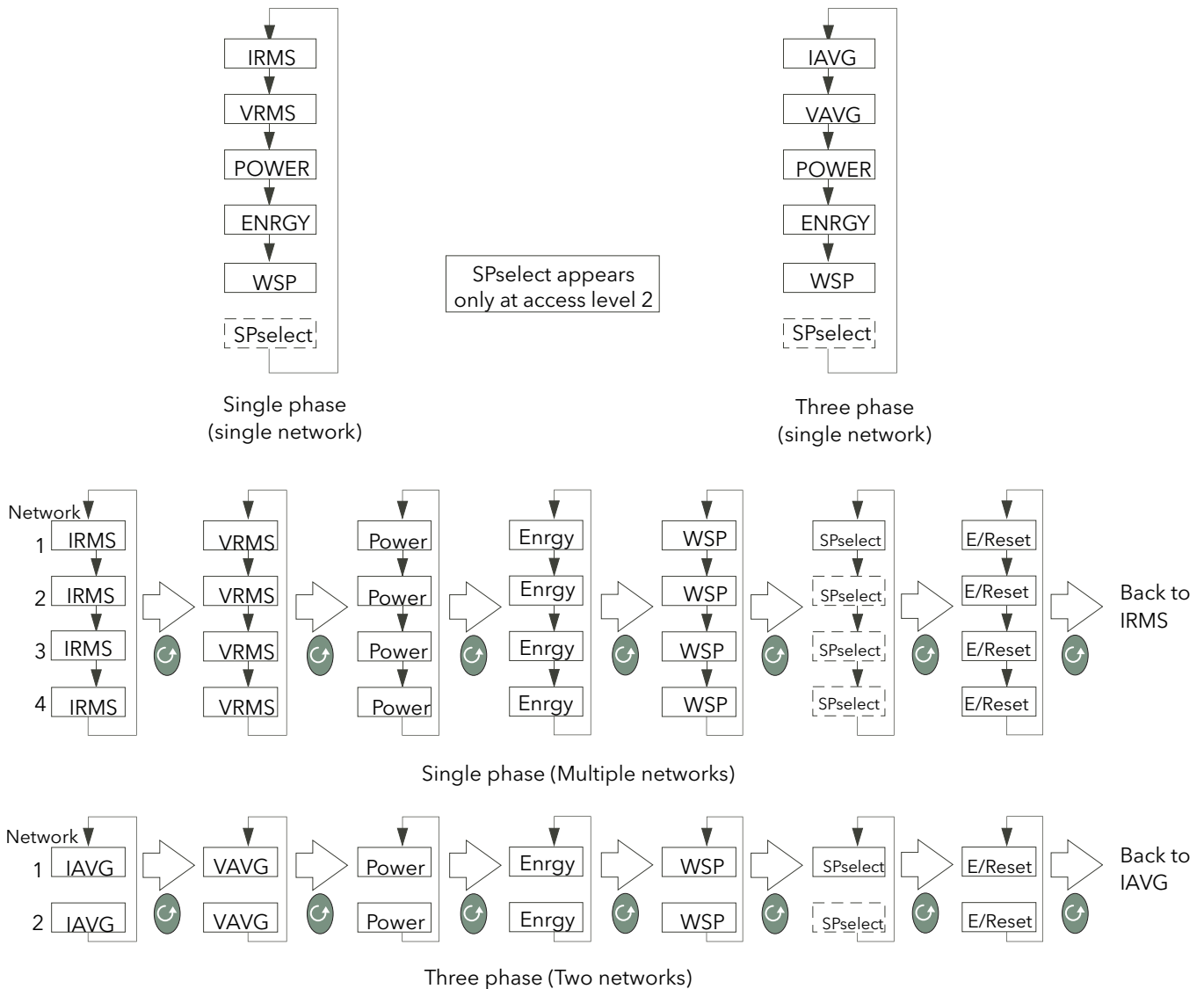

Figure A5.4.1b Various scrolling sequences

Note: For single networks, each EPower summary value (parameter) is displayed in turn. For multiple networks, the same parameter is displayed for each network in turn, the scroll key being used to select a different parameter if required.

A6 OTHER FEATURES

A6.1 ALARMS AND ERRORS

A6.1.1 Alarm indication

Up to four alarms can be set up in configuration level (refer to HA029006 for full details). Each alarm can be configured as 'nonE' (off), HI (high), Lo (low), r.roc (rising rate-of-change) or F.roc (falling rate-of-change).

If any alarm occurs the ALM beacon flashes, any output associated with the alarm becomes active, and the message area of the display shows a scrolling text message describing the alarm state. If the display is configured to go red on alarm (Set 2), the PV colour changes to flashing red.

A6.1.2 Alarm acknowledgement

Alarms are acknowledged by operating the Page key and the Scroll key simultaneously.

Further to this a global acknowledge of EPower alarms occurs when:

1. The indicator home page is selected, or
2. When the EPower Home page is displayed and the Home page is hidden

The results of alarm acknowledgement are as follows:

1. For EPower alarms, the alarm indication at the EPower operator interface is acknowledged (removed). The alarm indication remains at the 32h8e until the alarm is no longer active.
2. For Temperature (Process) auto-latching alarms, the alarm beacon and Process value stop flashing. Any output assigned to the alarm continues to operate until the alarm trigger is no longer active. If configured to change colour (Set 2), the process value returns to green only when the alarm trigger is no longer active.
3. For Temperature (Process) manual-latching alarms, acknowledgement has no effect, and the alarm indication continues until the alarm trigger is no longer active.
4. When EPower and auto-latching process alarms are both present, acknowledgement causes the beacon and Process Value (PV) display to stop flashing. Should the Process Value alarm subsequently go non-active, leaving only the EPower alarm, the beacon and PV display will resume flashing. For manual-latching alarms, acknowledge is ignored and the alarm indication continues until the alarm trigger is no longer active.

Note: Alarm parameters can be configured in Configuration mode, as described in the 3200i Engineering handbook HA029006.

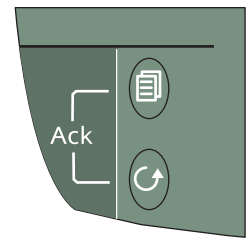

A6.1.3 Sensor Break detection and indication

An alarm condition (Sbr) is indicated if the indicator detects a break, or over range condition in the temperature sensor circuit.

Notes:

1. For a resistance thermometer a sensor break is indicated if any of the three wires is broken.
2. mA sensor breaks are not detected because the effect is masked by the resistor across the input.
3. For Volt inputs, sensor breaks might not always be detected, because the effect is masked by the attenuator (potential divider) board connected across the input.

A6.1.4 Error indication

The following error indications can appear, flashing, in the top line of the display:

Com.Er	Communication error. Modbus transactions between the 32h8e and the EPower driver module fail. Can be caused by a break in the physical communications link, by the EPower module being powered down etc.
EP.CnF	The number of power modules is selected as zero. The indicator can therefore not show Current, Voltage or Power values.
EP.Er	One or more 'Fatal', 'Config' or 'Standby' error has been detected.

The error condition(s) must be cleared before the 32h8e will respond to operator keystrokes.

A6.1.5 EPower Event and Alarm Messages

The messages shown below are generated by the EPower module and are displayed as scrolling text strings in the 'Message centre' area of the display.

MISS MAINS	Supply power to one or more power modules is not connected, or is isolated.
THYR SC	A thyristor short circuit has been detected. In such a case, current flows even when the thyristor is not 'firing'.
OPEN THYR	A thyristor open circuit has been detected. In such a case, no current flows even when the thyristor is 'firing'.
FUSE BLOWN	One or more of the thyristor protection fuses has ruptured.
OVER TEMP	The thyristor heat sink temperature has exceeded the specified limit, and the thyristor has been shut down. The temperature must fall to below the specified limit (including the hysteresis value) before firing can re-commence.
VOLT DIPS	This detects a reduction in supply voltage. Detection threshold is set up in EPower configuration (Network/Setup).
FREQ FAULT	Supply frequency is below 47Hz or above 63Hz. Firing stops until the supply frequency has returned to a value between 47Hz and 63Hz.
PB 24V	The 24V power rail in a power module has failed. Firing stops and restarts only when the problem has been resolved.
TLF	Total load failure. The load connection from one or more power modules is missing or open circuit.
CHOP OFF	Triggered if the load current meets or exceeds a specified threshold for more than five seconds. Firing stops until either the alarm is acknowledged or until 100mS has elapsed, according to configuration. See Network/Setup for further details.
PLF	Partial Load Failure. The alarm is triggered if a change in static load impedance is detected over a mains cycle (phase angle mode) or burst period (burst or logic mode). The sensitivity of the measurement can be configured as described in the Network/Setup area of EPower configuration.
PLU	Partial Load Unbalance. This alarm is triggered when the difference between the maximum and minimum currents of a three-phase system exceeds a configurable threshold. See Network/Setup for further details.
VOLT FAULT	One or more phases missing or out of limits.
PRE TEMP	Acts as a warning that the operating temperature is unexpectedly high. This alarm becomes active before unit operation is stopped.
PMOD WDOG	One or more power module watchdogs has performed a reset.
PMOD COM ERR	A power module communications error has been detected. Typically this would be caused by a damaged inter-module ribbon cable.
PMOD T OUT	A power module communications time out error has occurred. Typically this would be caused by a damaged inter-module ribbon cable.
CLOSED LP	The control loop cannot achieve setpoint, despite the loop demanding 0% or 100% power. Typically caused by external constraints on the load.
OUT FAULT	A short circuit has been detected in the output circuit. Firing is inhibited.

A6.2 RECIPES

Note: Level two access (section A5.3) is required in order for the user to be able to save and/or restore 'recipes' as described below.

It is possible to store operating values by tacking a 'snapshot' of the current settings and storing these snapshots in one of up to five 'recipes'. An example would be to store several sets of alarm setpoint values, one of which can then be recalled for a particular process.

To store values in a recipe:

1. In the level two list of parameters (figure A5.3.1), press the scroll key repeatedly (or hold continuously) until 'STORE' appears.
2. Select a recipe number using the up/down arrow keys. After a few seconds the word donE appears to indicate that the current parameter values have been saved to the selected recipe number. Previous values are over-written without confirmation.

To retrieve a recipe:

1. In the level two list of parameters (figure A5.3.1), press the scroll key repeatedly (or hold continuously) until 'RECNO' appears, along with a number (between 1 and 5 inclusive) indicating which recipe was last selected.
2. Select the required recipe number using the up/down arrow keys. After a few seconds the recipe number will blink, to indicate that the load is complete. If the selected recipe is empty, the word FAIL appears instead of the recipe number.

A6.3 EPOWER SETPROV CONFIGURATIONS

If EPower is configured via QuickStart and the analogue input has been set to 'Setpoint', then, in a multiple network configuration, QuickStart will wire SetProv1 'workingSP' to the 'Main.SP' of all the networks' Control blocks so that all the control blocks share the same setpoint.

Figure A6.3, below shows two examples of this, as displayed in the iTools Graphical wiring editor.

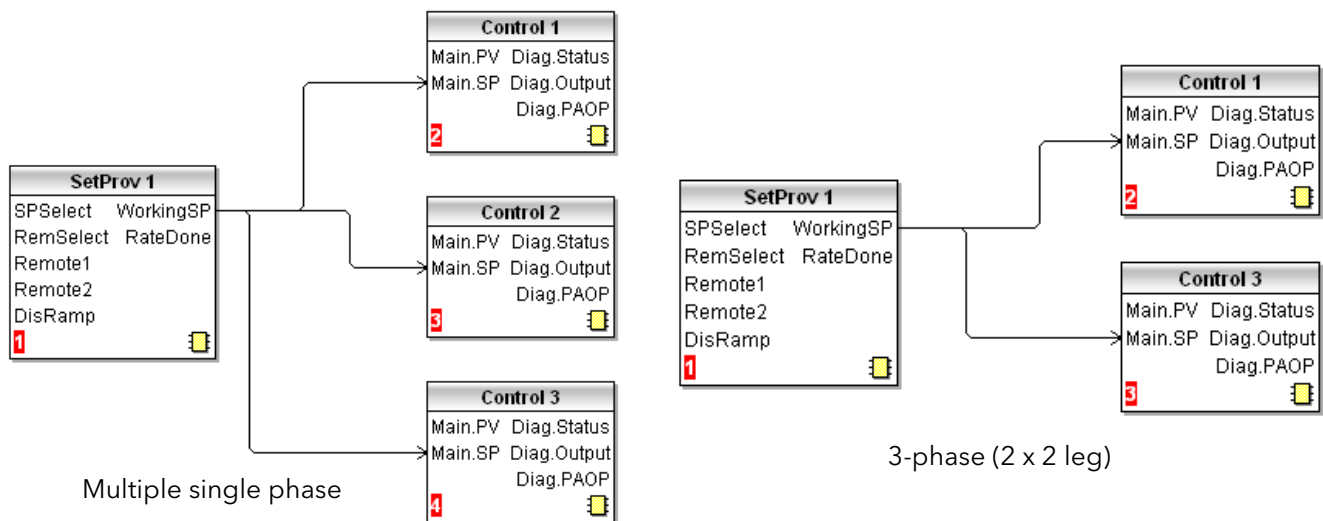

Figure A6.3 Setpoint to Control block wiring (iTools graphical wiring editor display)

A6.3 EPOWER SETPROV CONFIGURATIONS (Cont.)

If EPower is configured using QuickStart, and the analogue input is not set to 'Setpoint', then none of the SetProv function blocks is enabled and each control block setpoint can be set locally.

If EPower is configured using the iTools Graphical wiring editor, then it is possible to enable all of the SetProv function blocks, thus allowing each control block to have individual local or remote setpoints. This flexibility has an effect on the operation of the REM and MAN beacons, as described in [section A5.1.1](#).

A6.3.1 Setpoint availability

MULTIPLE SINGLE PHASE CONFIGURATION

Figure A6.3.1a shows three examples of different single phase setpoint configurations. Figure A6.3.1b, is similar, but shows three-phase 2 x 2 leg examples.

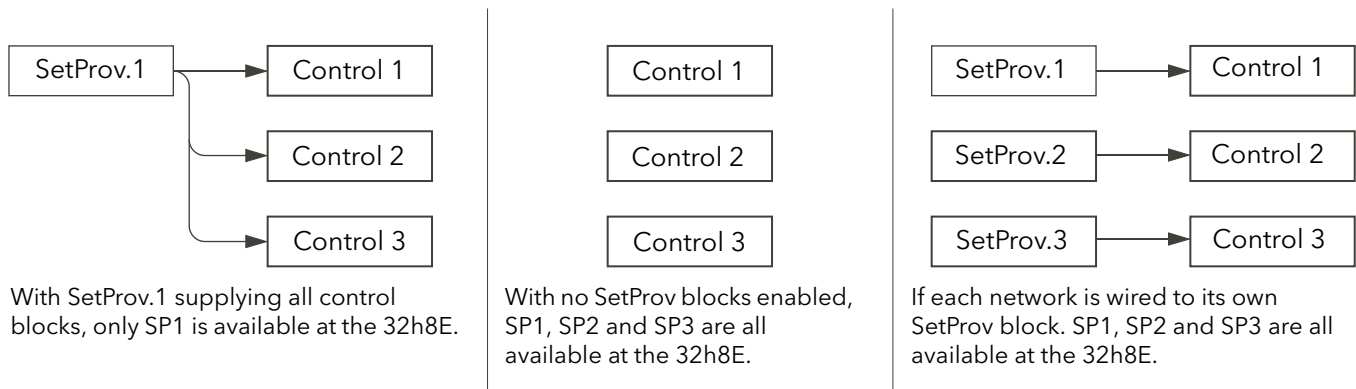

Figure A6.3.1a Setpoint availability (multiple single phases)

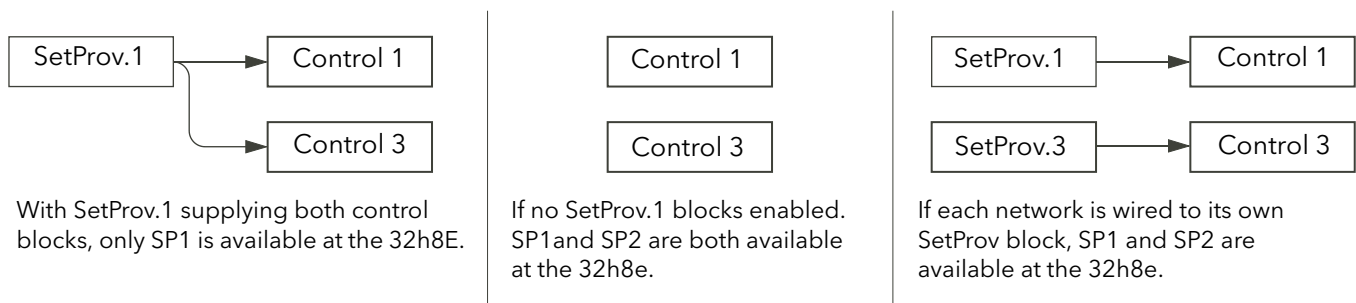

Figure A6.3.1b Setpoint availability (three-phase 2 x 2 leg)

A6.4 PV RETRANSMISSION

EPower parameters may be communicated to a Fieldbus Network Master i.e. SCADA package, PLC or DCS system. The 32h8e is intended as an independent policeman, and its process PV may also be communicated to the Fieldbus network master. To this end, the 32h8e PV is written every 1/2 second to the EPower's Instrument.Config.RemotePV parameter, which can then be transmitted to the master device.

PV retransmission is also provided as an analogue (V or mA) signal at the analogue output OP3. This may be used as a back-up to the digitally communicated parameter in the event of a failure of the communications link.

A6.5 DIGITAL ALARM OPTIONS

The following source parameters can be logically OR'ed together to give a digital output state.

1.SRC.A
1.SRC.B
1.SRC.C
1.SRC.D
EP.AL

1.SRC.A to 1.SRC.D are described in the Engineering Handbook (HA029006); EP.AL is defined as: All EPower alarms.

Note: the ALL.A (All Alarms) parameter includes the above EP.AL as well as the indicator alarms.

A6.6 HOME PAGE TIMEOUT

The 32h8e normally forces the display to return to the Home page after a period of keyboard inactivity.

If, however, the current focus is on an EPower parameter, then the HOME Page timeout is not imposed, thus allowing the user to display a specific Network parameter indefinitely (providing that auto-scrolling is disabled).

Restriction of Hazardous Substances (RoHS)
Product group 3200

Table listing restricted substances

Chinese

限制使用材料一览表

产品 3200	有毒有害物质或元素					
	铅	汞	镉	六价铬	多溴联苯	多溴二苯醚
印刷线路板组件	X	O	X	O	O	O
附属物	O	O	O	O	O	O
显示器	O	O	O	O	O	O
O	表示该有毒有害物质在该部件所有均质材料中的含量均在SJ/T11363-2006标准规定的限量要求以下。					
X	表示该有毒有害物质至少在该部件的某一均质材料中的含量超出SJ/T11363-2006标准规定的限量要求。					

English

Restricted Materials Table

Product 3200	Toxic and hazardous substances and elements					
	Pb	Hg	Cd	Cr(VI)	PBB	PBDE
PCBA	X	O	X	O	O	O
Enclosure	O	O	O	O	O	O
Display	O	O	O	O	O	O
O	Indicates that this toxic or hazardous substance contained in all of the homogeneous materials for this part is below the limit requirement in SJ/T11363-2006.					
X	Indicates that this toxic or hazardous substance contained in at least one of the homogeneous materials used for this part is above the limit requirement in SJ/T11363-2006.					

Approval

Name:	Position:	Signature:	Date:
-------	-----------	------------	-------

Martin Greenhalgh

Quality Manager

07/FEB/2007

IA029470U600 (CN23172) Issue 1 Feb 07

This page is deliberately left blank

APPENDIX B THREE PHASE FEEDBACK

B1 TRANSFORMER REPRESENTATION AND LABELLING

Note: The current transformer should be chosen such that its full-scale output is 5 Amps.

Figure B1, shows a common way of showing typical three phase transformers of various types. Each type is useful for particular applications, for example a Delta primary helps with a more even distribution of loading if the secondary loads are not well matched, whilst a Star wound secondary provides a convenient Earth or Neutral tap for connection near the transformer.

For closed systems, windings corresponding to a particular phase are marked with a prefix number indicating that phase, for example '1P' and '3S' represent phase one primary and phase three secondary respectively. For open Delta systems, each winding is identified by two labels; for example, 1S1 and 1S2 represent the two ends of phase one secondary whilst 2P1 and 2P2 would represent the phase two primary.

The voltages and currents in any one phase are tightly coupled and the primary and secondary voltages are (more-or-less) in phase with one another. Each phase is 120 degrees out of phase with the other two.

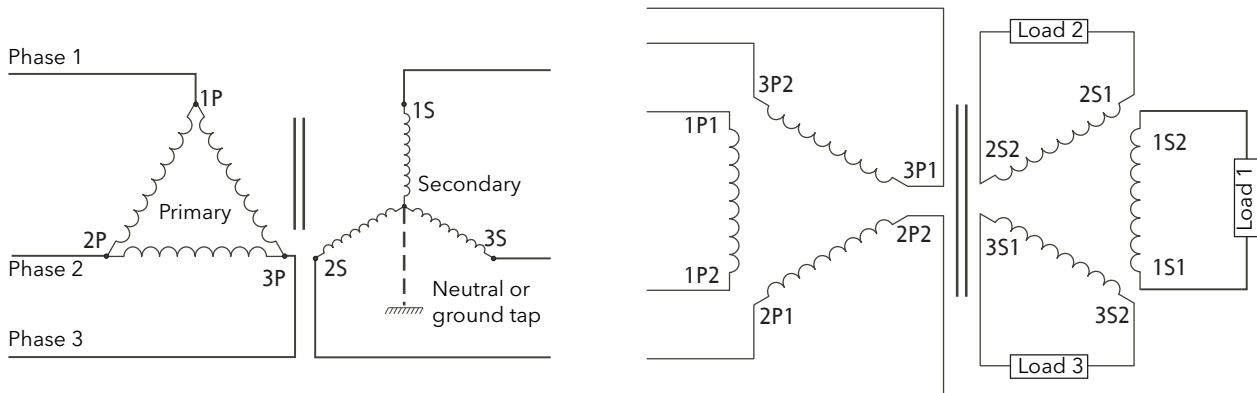

Figure B1 Figure B1 typical transformer winding labelling

B2 EXTERNAL FEEDBACK PHASING

External feedback consists of both current measurement (using a current transformer) and voltage measurements across the load (tap locations depend on the network layout). The signals from these feedback elements are terminated at a connector located on the underside of the power units, as shown in figure B2.

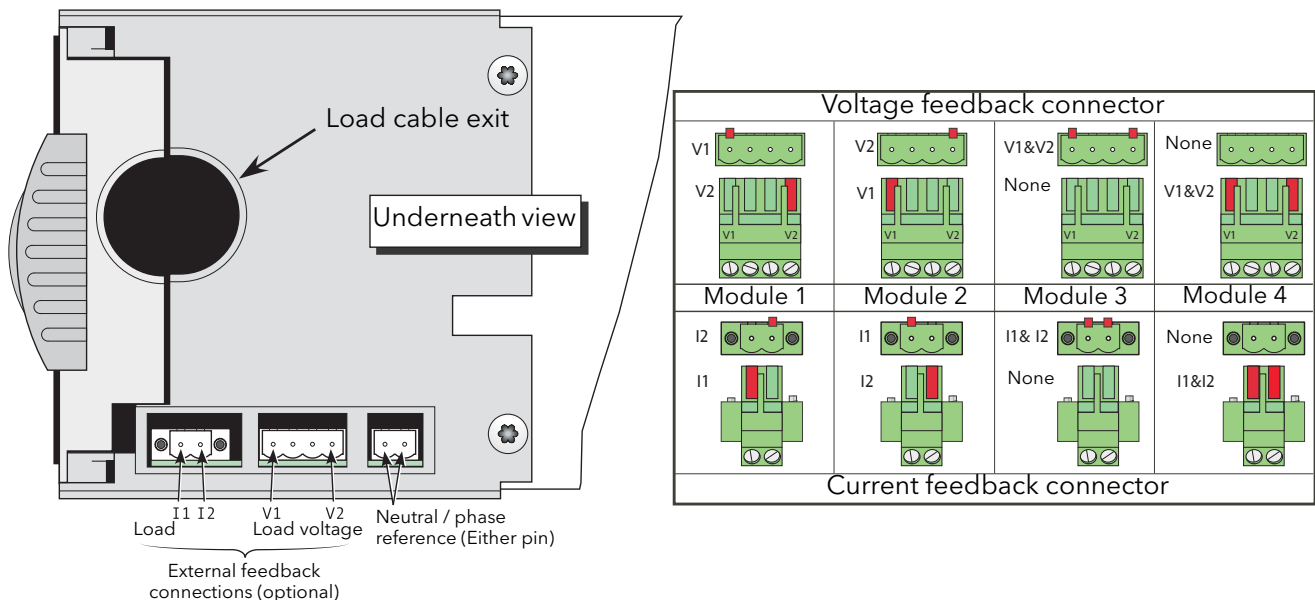

Figure B2 External feedback connector locations and pinout

B2.1 CURRENT TRANSFORMER CONNECTION

Conductor carrying current to be

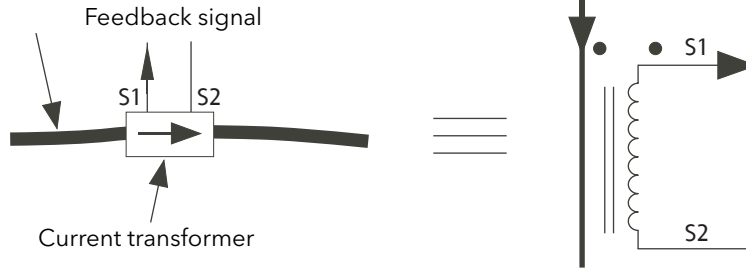

Figure B2.1a Current transformer labelling

The current transformer terminal S1 must be connected to terminal I1 of the relevant power unit; the current transformer terminal S2 must be connected to the power unit terminal I2.

Note: S1 and S2 here are not related to the load transformer secondary labels S1 and S2.

The arrow on the current transformer must point towards the load, if the associated voltage tapping is connected to V1; The arrow on the current transformer must point away from the load if the voltage tapping is connected to V2. Figure B2.1b shows some correct and some incorrect examples.

Arrow must point towards the load, if the associated voltage feedback is connected to V1.

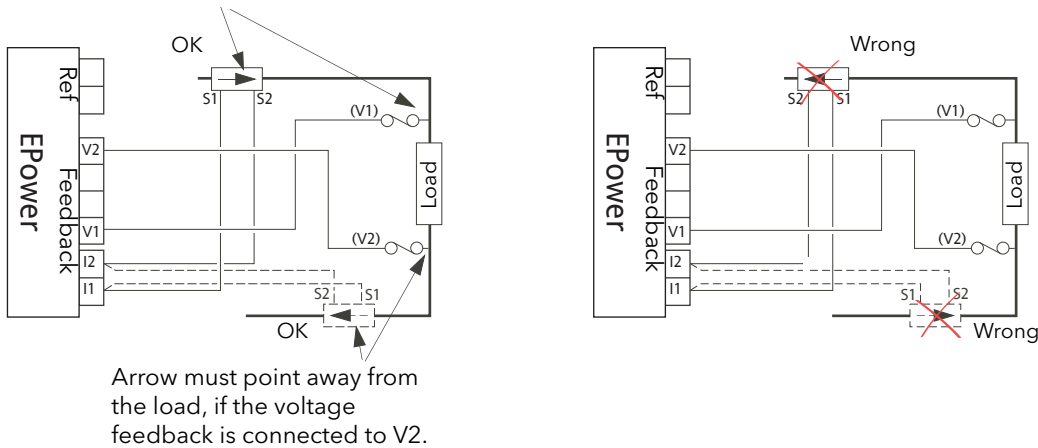

Arrow must point away from the load, if the voltage feedback is connected to V2.

Figure B2.1b Current transformer orientation

Notes:

1. In each part of the drawing above, the two positions (i.e. solid and dashed) for the current transformer are alternatives - only one should be used in any one phase.
2. The fuse value for voltage feedback wiring should be chosen to suit the current-carrying capability of the cable it is protecting.

B2.2 FEEDBACK EXAMPLES FOR TYPICAL THREE PHASE NETWORKS

CAUTION

Where applicable, reference connections to phase power or to neutral must be located between any isolating device and the relevant Power Module.

Note:

1. The figures below are intended only as theoretical examples. In order to comply with NEC requirements, branch circuit protection must be incorporated by the user, upstream of the equipment. Such protection is not shown in the figures below, for the sake of clarity. The installation, in its entirety, must comply with all applicable local safety and emissions regulations.
2. For pdf viewers, the colours used in the figures below are used only to improve clarity. No polarity should be inferred (e.g. blue wires are not necessarily neutral; red is not positive etc.)

B2.2.1 Two phase control with Delta-Star transformer and 3S load

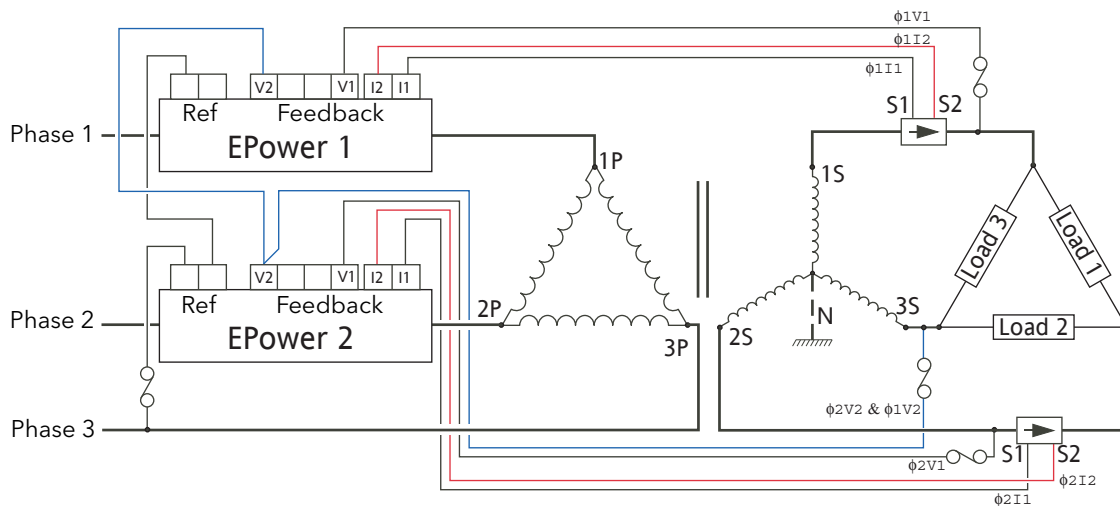

Figure B2.2.1 Two phase control with Delta-Star transformer and 3S load

B2.2.2 Two phase control with Delta-Star transformer and 3D load

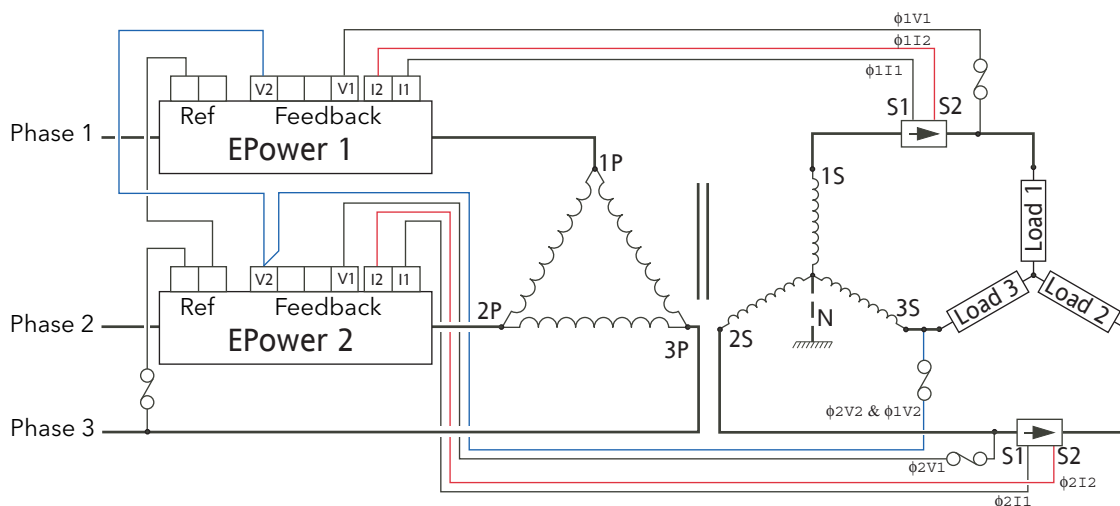

Figure B2.2.2 Two phase control with Delta-Star transformer and 3D load

B2.2.3 Three phase control with Delta-Star transformer and 3S load

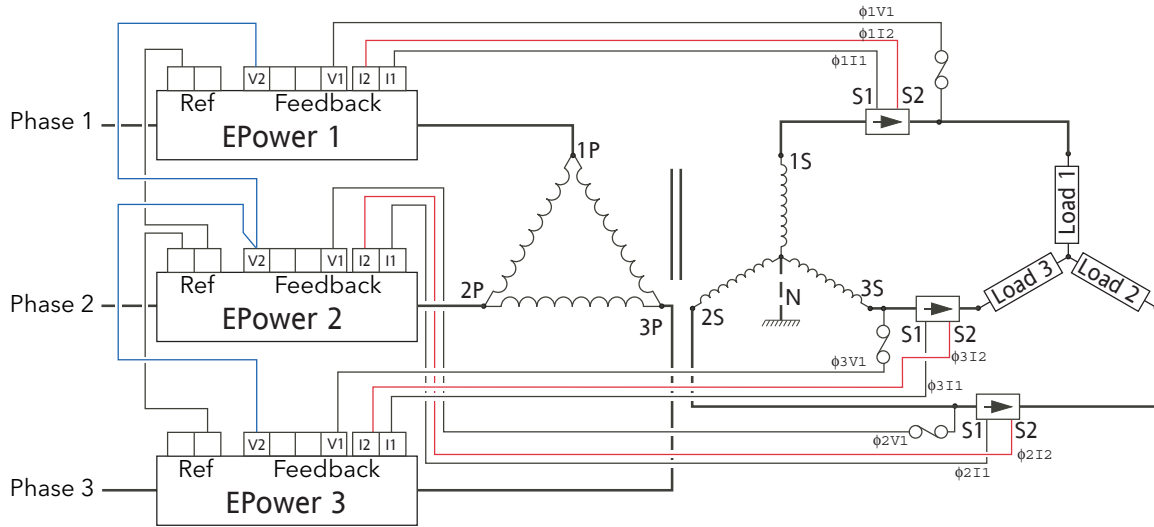

Figure B2.2.3 Three phase control with Delta-Star transformer and 3S load

B2.2.4 Three phase control with Delta-Star transformer and 3D load

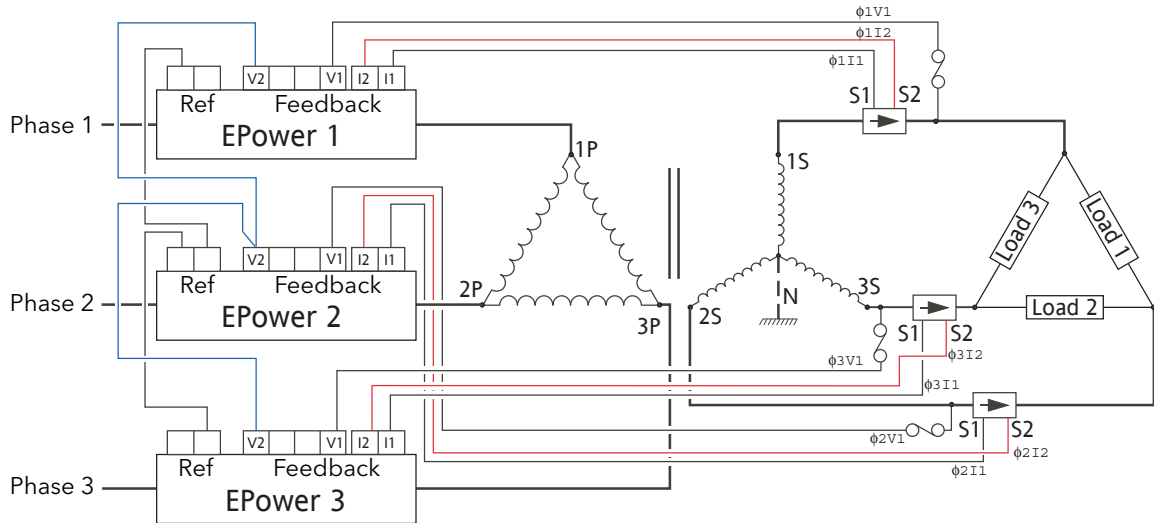

Figure B2.2.4 Three phase control with Delta-Star transformer and 3D load

B2.2.5 Three phase control with Star-Star transformer and 4S load

CAUTION

The star-star configuration is not recommended as it may become unsafe under fault conditions and permanent damage to one or more power units may result.

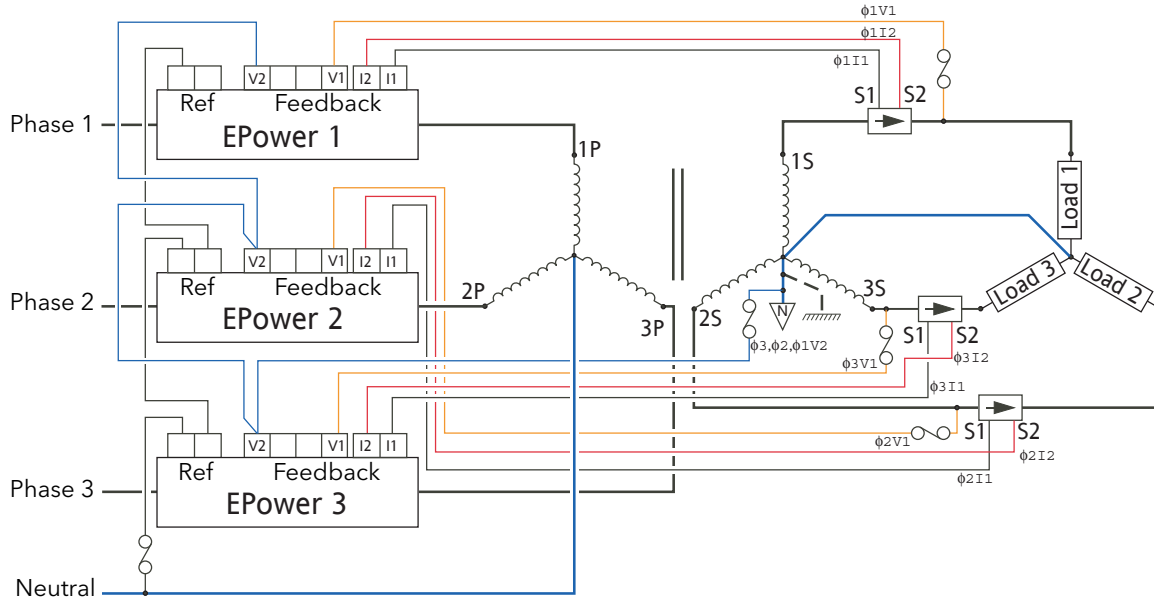

Figure B2.2.5 Three phase control with Delta-Star transformer (primary and secondary with neutral tap) and 4S load

B2.2.6 Three phase control with Delta-Delta transformer and 3S load

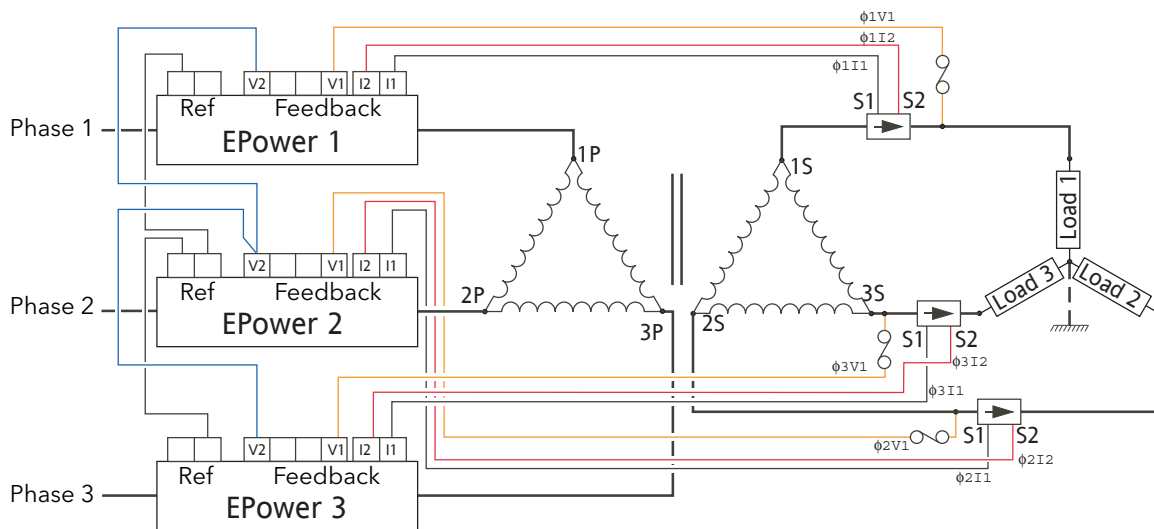

Figure B2.2.6 Three phase control with Delta-Delta transformer and 3S load

B2.2.7 Three phase control with 6D primary and 4S secondary with 4S load

Commonly used in salt baths and other heat treatment applications, this configuration results in lower thyristor currents (and therefore costs) at the expense of higher cabling costs.

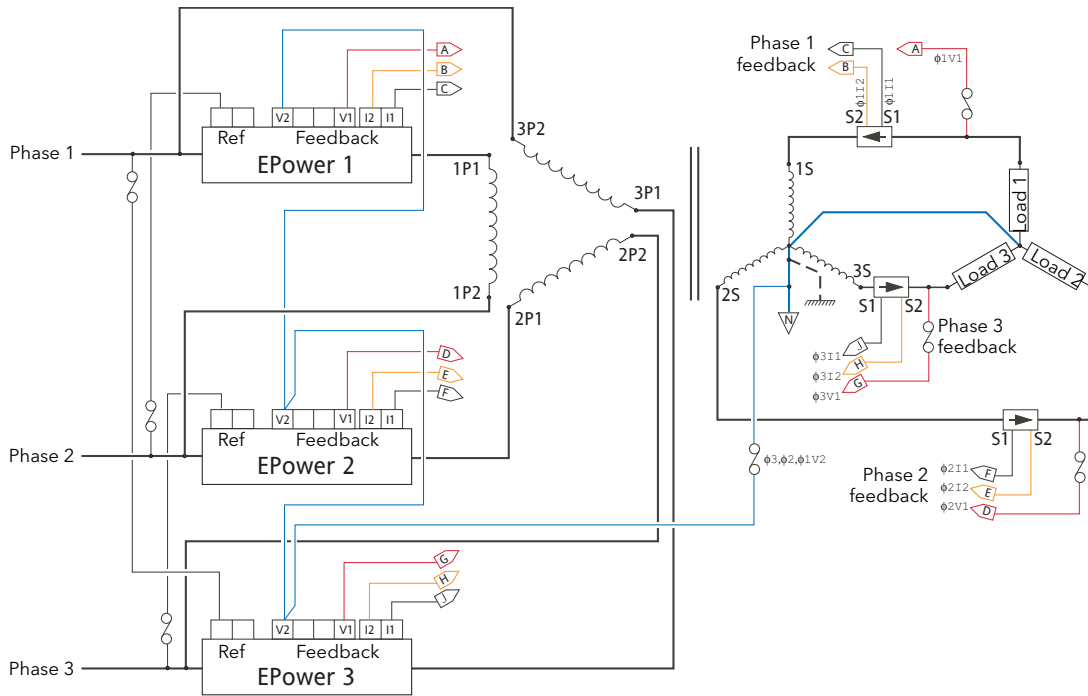

Figure B2.2.7 Three phase control with open delta primary and four-wire star secondary, driving 4S load.

B2.2.8 Three phase control with 6D primary /secondary with three independent loads

Rarely used - not recommended because this configuration is not fault tolerant.

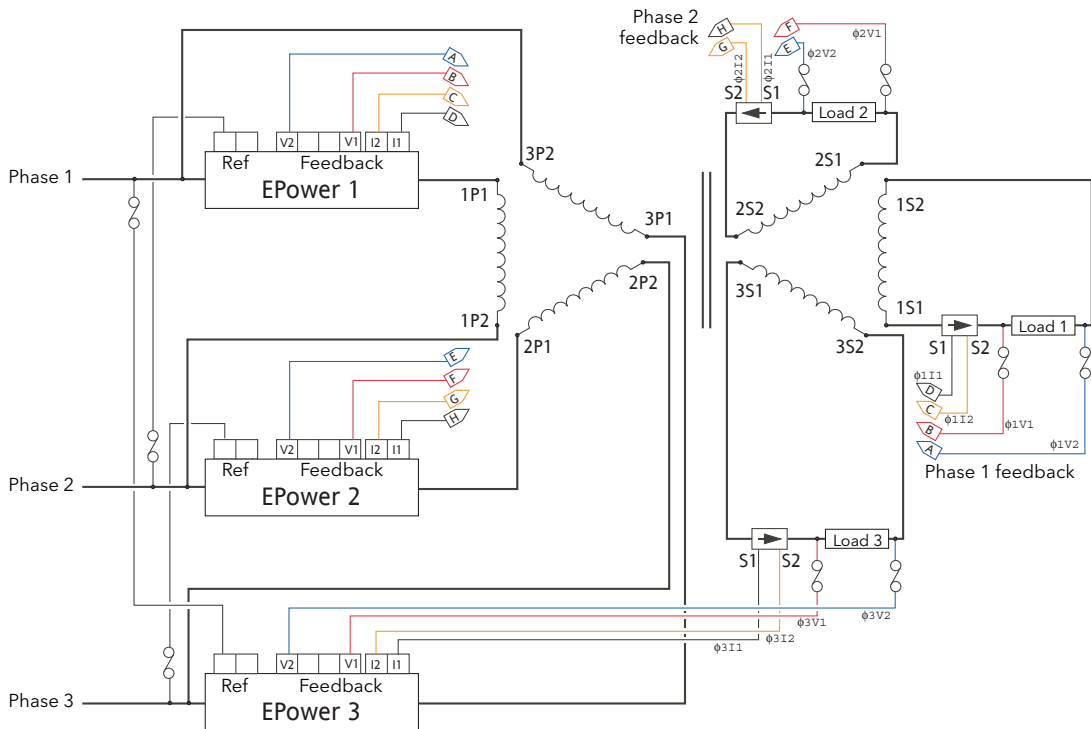

Figure B2.2.8 Three phase control with open delta primary/secondary and four-wire star secondary, driving three independent, floating loads

Index

Symbols

<	91
<=	91
<>	91
==	91
>	91
>=	91

Numerics

10 x	95
2-leg wiring	39, 41
3-delta wiring	38, 41
Two leg	39, 41
3-star wiring	37, 40
4-star wiring	37
6-delta wiring	38, 40

A

A1	234, 238
A1Fuseln	112
A1Templn	112
AbsDif	95
Access	
Codes	58
Menu	58
Acknowledge alarms	42, 76, 231, 242
Add	95
Adding parameters to the Watch list	146
ADDR	238
Address	65, 66, 205
Predictive load management	107
AlarmOut	121
Alarms	
Acknowledgement	42, 76, 231, 242
Global	84
Beacon (Remote panel)	242
Days / Time	90
Detection	73
Disable	72, 103
Indication	213, 242
Latch	75
Overview	211
Process	212
Signalling	74
Summary pages	53
System	211
AlarmSP	121
Align Tops/Lefts	135
Alm	238
ALM beacon	231, 242
ALM indicator	43
AlmAck	
Analogue output	63
Control	76
Load Management	109, 112
Network	104
AlmDet	
Analogue output	63
Control	73
Load Management	109, 112
Network	104
AlmDis	112

Analogue output	63
Control	72
Load Management	109
Network	103
AlmLat	
Analogue output	63
Control	75
Load Management	109, 112
Network	104
AlmSig	
Analogue output	63
Control	74
Load Management	109, 112
Network	104
AlmStop	
Analogue output	63
Control	77
Load Management	109, 112
Network	104
Altitude (maximum)	215
Analog IP	
Func	46
Menu	61
Specification	216
Type	46
Analog OP	62
Func	46
Modbus parameter addresses	164
Specification	216
AnalogIP	
Modbus parameter addresses	163, 164
AND	91, 93
Any Alarm	84
ASCRL	240
Atmosphere operating spec	215
Auto scrolling	240, 241
Autoscale	82
B	
Back to:	140
Bar Graph Title 1	149
Bar Graph Title 2	149
Baud	65, 66
Beacons	43
Black wiring editor items	135
Block execution order	129
Blue	
Arrow	
Down	147, 150
Left/Right	140
Parameters	139
Wiring editor items	135
Bring To Front	
Function block context menu	131
Monitor context menu	134
Wire context menu	133
Burst	
Fixed	48
Variable	49
C	
Capture current values into a data set	147
CC-Link	

Pinout.....	28	Copy	
Specification.....	219	Comment.....	133
Centre.....	135	Diagram fragment.....	129
Chain icon.....	134	Fragment to file.....	135
Checksum fail error.....	142	Function block context menu.....	135
Chop Off.....	51, 103, 243	Graphic.....	135
ChopOff.....	43	Graphical Wiring Editor.....	129
ChopOff1Threshold.....	101, 212	Monitor.....	134
ChopOff2Threshold.....	101, 212	Parameter.....	140
Cleaning.....	220	Wire context menu.....	132
Clear the selected data set.....	147	Wiring editor items.....	135
Click to Select Output.....	130, 132	Count.....	79
Clip Good, Clip bad.....	95	Counter	
Closed Loop		Menu.....	78
Alarm Acknowledge.....	76	Modbus parameter addresses.....	157, 158
Alarm detection.....	73	Create a new empty data set.....	147
Alarm disable.....	72	Create a new watch/recipe list.....	147
Alarm Latch.....	75	Create Compound.....	129, 135, 136
Alarm Signalling.....	74	CTL.SP.....	240
Alarm Stop.....	77	Current feedback.....	30
CLOSED LP.....	243	Current transformer (external).....	30
ClosedLp.....	43	Connection.....	250
Cold Start.....	43	Custom Pages	
Colours		Modbus parameter addresses.....	158, 159
Function blocks etc.....	135	Cut	
Software wiring.....	133	Comment.....	133
Column enable/disable.....	139, 140	Function block context menu.....	131
Com.Er.....	243	Graphical Wiring Editor.....	129
Comments.....	133	Monitor.....	134
Context Menu.....	133	Wire context menu.....	132
Comms		Wiring editor items.....	135
Gateway tool.....	141	Cycle Time.....	96
Menu.....	64	D	
Modbus parameter addresses.....	154	D.....	194
Pinouts.....	27	Dashed lines.....	137
Remote Panel.....	66, 228	Data set creation.....	146
Specification.....	219	Days above.....	90
User menu.....	65	Delay	
Component Selection.....	129	(Comms).....	65
Compounds.....	136	Time.....	194
Conf Entry.....	43	Delayed Trigger.....	86
Conf Exit.....	43	Delete	
Conf level Operation (Remote panel).....	239	Comment.....	133
Configuration level menu.....	55	Function block context menu.....	131
Configuration Port.....	26	Monitor.....	134
Context Menu		Wire.....	133
Function block.....	130	Wiring editor items.....	135
Wire.....	132	Derating information.....	215
Control		Device Panel.....	145
Menu		DeviceNet	
AlmAck.....	76	Pinout.....	27
AlmDet.....	73	Specification.....	219
AlmDis.....	72	DHCP Enable.....	65
AlmLat.....	75	Digital I/O	
AlmSig.....	74	Modbus parameter addresses.....	165
AlmStop.....	77	Specification.....	216
Diag.....	71	Digital IP 'Func'.....	46
Limit.....	70	Direct Connection (iTools).....	126
Main.....	69	Direction.....	78
Overview.....	67	Display.....	42
Setup.....	68	Language.....	87
Modbus parameter addresses.....	154, 155, 156, 157	DisRamp.....	118
Control and Setpoint Display.....	240	DistIncr.....	106, 191, 204

Distrib	106, 191, 204
Distributed control	191
Div	95
Down arrow key	42, 231
Download the selected data set to the device	147
Download wiring to instrument	129, 134
DownScale	95
Driver Unit	
Fan supplies	20
Signal wiring	22
DSP Wdog	44
DSPnoRSP	44
DuplAddr	206
Duplicate Address	206
Duty cycle	187, 194
Limiting	51
E	
E.RST	234, 237
Edit	
Comment	133
Parameter for selected item	150
Parameter Value	131
Style for selected item	150
User text for selected item	150
Wire	140
EE Checksum fail error	142
Efficiency	108, 208
Efficient Power	194
Electrical installation	
Driver unit	20
Thyristor power unit	30
EMC information	223
Enable	
Counter	78
Firing	86
Input	20
Energy Counter	81
Modbus parameter addresses	159, 160
Resolution	83
Energy counter	237
Energy Reset	234, 237
Engineer level menu	55
EngWorkingSP	118
ENRGY	234, 237
Enter key	42
Environment	
Specification	215
EP.AL	246
EP.CnF	243
EP.Er	243
EP.I	238
EP.P	238
EP.U (EP.V)	238
EPower	
Panel installation	14
Unpacking	13
ErrDSP	44
Error	66
Indication (Remote panel)	243
ErrRestart	44
EtherNet	
Specification	219
Status	66
Ethernet I/P	
Pinout	28
Specification	219
Event Log	53
Modbus parameter addresses	160
Exp	95
External	
Current feedback	30
Phrasing examples	249
Wiring specification	215
F	
F	193
F.roc	242
Fall Good, Fall Bad	95
Fall type	92
Fallback	95
Fallback value	95
FalseGood/FalseBad	92
Fan supplies	20, 214
Fault	66
Faultdet	84
Modbus parameter addresses	162
Feedback mode	50
Feedback phasing	249
FFGain	68
FFOffset	68
FFType	68
Find	
End	132
Start	132
Finish	47
Firing angle limiting	51
Firing Enable	20
Firing Mode	46, 48, 85
FiringOP	85
Modbus parameter addresses	162, 163
Flatten compound	129, 136
Follow Wire	140
Force Exec Break	132
Forward to:	140
Four star wiring	37
FREQ FAULT	243
Freq Fault	103, 211
FreqDriftThold	24, 101
Frequency	99
Function Block	130
Context menu	130
View	130
Fuse	
Alarm	84
Blown	24, 103, 211, 243
Driver Module	20
Phase/Reference input	37
Thyristor protection	221
FuseBlown	43
FuseConfig	44
G	
Gateway 1 to 4	65
Ghosted wiring editor items	137
Global Ack	84
Global Disable	84
GlobalAck	43

Go Up/Down a Level	140	Input 1 (2)	92
GoTo	59	Scale	95
Graphical Wiring Editor	128	InputBrk	43
Greyed-out wiring editor items	137	Insert item ahead of selected item	
Grid on/off	129	User pages	150
Group	206	Watch/Recipe	147
H		Installation	
Half cycle mode	49	Electrical	
HeaterType	102	Driver module	20
HeatsinkPreTemp	212	Remote panel	226
HeatsinkTmax	101	Thyristor power unit	30
HHOME	240	Mechanical	14
HI	242	160 Amp units	16
Hidden parameters	139	250 Amp units	17
Hide		400 Amp units	18
Homepage	240	50/100 Amp units	15
Unwired Connections	131	500 Amp units	19
HIGH	234, 238	Remote panel	225
High Limit	95	Instr	65
HiRange	118	Instrument	
HMI	42	Menu	87
Hold	121	Modbus parameter addresses	163
HOME	238	Invert	80, 92, 93
Home Page Timeout (Remote panel)	246	InvPAdata	44
HotSwp	95	InvRamCsum	44
HSink1 (2) (3) Temp	99	InvWires	44
Humidity limits	215	IO Modules	88
HWDiffers	44	Specification	216
Hysteresis	92	IP	112
I		IP Address	65
I Average	99	IP Monitor	
I, I2, I3	99	Menu	89
I ²	99	Modbus parameter addresses	165, 166
I ² Burst	99	IP1 Pref Master	65
I ² Max	99	IRMS	234
I AVG	234	Irms Max	99
ID	65	IRMS1(2)(3)	234
Idle	66	IsGlobal	82
IextScale	100	IsMaster, IsSlave	206
IMaximum	100	iTools	123-150
In		Connection	124
Firing Output	86	with Load Management	201
Input monitor	90	L	
Timer	120	Language	46, 87
Totaliser	121	LATCH	91
In1		LEDs	43
Lgc8	93	Left arrow key	42
Maths	95	Left origin Bar	149
In2	95	Level 1 operation (Remote panel)	232
Incremental control		Level 2 operation (Remote panel)	236
Distributed	191	Level 3 operation (Remote panel)	239
Type 1	188	Lgc2	91
Type 2	189	Modbus parameter addresses	166, 167
IncrT1	106, 188, 204	Lgc8	93
IncrT2	106, 189, 204	Modbus parameter addresses	167
Indication Alarms	213	Limit	118
Init	66	Limit 1(2)(3) active	71
INominal	100	Limit Enable	68
Input		LimitAct	43
Definition	141	Limitation	
Energy counter	82	Alarm Acknowledge	76
Modulator	96	Alarm Detection	73
		Alarm Disable	72

Alarm Latch	75	Frequency fault alarm	211
Alarm Signalling	74	Network measurements	219
Alarm Stop	77	Voltage fault alarm	212
Limitation active	213	Wiring	
Line and Load terminations	32	Driver unit	20
Line power wiring		Thyristor power unit	30
Driver unit	20	MainsFreq	43
LMoverSch	43	Maintenance	220
Ln	95	MainVFault	43
Lo	242	MAN beacon	231, 232
Load		Master Address	108
Coupling	46, 88	Master election process	209
Management	186-210	MasterAddr	209
Address	47, 205	Math2	
Alarm menus	109	Menu	94
Configuration with iTools	201	Modbus parameter addresses	168, 169
Connector	25	Max	90
General description	186	MaxInom	102
Interface	110	Meas	98
Main menu	105	MeasVal	
Network menu	108	Analogue input	61
Station menu	107	Analogue output	62
Trouble shooting	210	Digital I/O	80
Type	47	Relay	116
Sequencing	188	Mechanical Installation	
Sharing	25, 193	160 Amp units	16
Shedding	25, 108, 195	250 Amp units	17
Comparisons	197	400 Amp units	18
Type	46, 85	50/100 Amp units	15
Types	214	500 Amp units	19
Wiring examples	37	Min	90
Load Over-Current	213	Min On	120
Load Tap Changer	111	Time	96
Modbus parameter addresses	168	Minimum off time	96
LoadMng		Missing mains	24
Blocks	203	Alarm	211
Modbus parameter addresses	181	MissMains	103, 211, 243
LoadOverl	43	Missmains	43
LOC indicator	43	Modbus RTU	
Local/Remote switching	43	Pinout	27
LocalSP	118	Specification	219
Log	95	Mode	
LogFault	44	Firing OP	85
Logic firing mode	48	Modulator	96
Logic Mode	96	Modulation period (T)	187
Loose	65	Modultr	96
LOW	234, 238	Modbus parameter addresses	169, 170
Low Limit	95	Monitor	134
LTC		Mouse	
Alarm	112	Pan	129
A1Fuse	112	Select	129
A1Temp	112	Move selected item	
Application Wiring	113	User Pages	150
MainPrm	112	Watch/Recipe	147
Option	111	Mul	95
M		N	
MAC1 to MAC6	66	NetStatus	66
Magenta wiring editor items	135	NetwDip	43
Main		Network	
Analogue output	62	Alarm	84
PV	71	Acknowledge menu	104
MainPrm	112	Detect menu	104
Mains		Disable menu	103

Latch menu	104	PA Limit	71, 86
Signalling menu	104	Page key	231
Stop firing menu	104	Pan tool	129
Communications menu	66	PAOP	112
Dips	211	Parameter	
Menu	97	Blue	139
Meas.	98	Explorer	138
Setup	100	Help	131, 134, 140
Modbus parameter addresses	170, 173, 176, 178	Properties	131, 140
Type	46, 88, 100	Parity	65
Network dips	24	Remote Panel	66
Neutral reference input	31	Partial Load Failure (PLF)	
No.	106	Alarm	213
Nominal Current	46	Calculations	102
Nominal Voltage	46	Partial Load Unbalance (PLU)	213
nonE.	242	Pass Code editing	60
Num Chans	107	Paste	
Number of inputs	93	Comment	133
NumberChopOff	101	Diagram fragment	129
NumChan	207	Error	131
O		Fragment From File	135
Occupied Stations	65	Function block context menu	131
Off.	91	Graphical Wiring Editor	129
On		Monitor	134
Delay	119	Wire	140
Pulse	119	Wire context menu	132
One Shot	120	Wiring editor items	135
OP1 to OP4	112	PB 24V	103, 211, 243
Beacons (LEDs)	231	PBurst	99
OPC	147	Peak Reset	238
Open an existing watch/recipe file	147	Pending	210
Open Thyr	103, 243	Period	106, 204
Oper.	91	PF	99
Operation	93	Ph'n'ComErr	44
Operator		Ph'n'ComTout	44
Interface	42	Ph'n'Wdog	44
Menu	52	Phase angle	
Operator interface		Control	49
Specification	215	Reduction burst firing	70
OR	91, 93	Phase reference	31
Out		Input fuse	37
Fault	243	Polarising pins	32
Invert	93	Pinout	
Maths	95	CC-Link	28
Resolution	95	Communications	27
Timer	120	DeviceNet	27
Units	95	Ethernet I/P	28
OutFault	43	Input/Output	22
Output	71, 92	Load management	25
Definition	141	Modbus RTU	27
Modulator	96	Modbus TCP	27
Short circuit alarm	212	Profibus	27
Over I	103	Profinet IO	28
Over Load Shedding	213	Relay 1	24
Over Temperature	103, 211, 243	Remote panel	226
Overflow	78	Connector	29
OverIThreshold	102, 213	Watchdog relay	24
OverTemp	43	PLF	43, 103, 243
OverVoltThreshold	101, 212	Adjusted	101
P		Adjustment request	42
P	99	AdjustReq	101
P.A.ro	238	Calculations	102
		Sensitivity	101

PLM Channel		
Configuration with iTools	201	
PLM Type	204	
PLMChan	110	
Blocks	202	
Modbus parameter addresses	181, 182	
PLMIn	96, 110	
PLMOut	110	
PLMOut 1 to 4	107	
PLU	43, 103, 243	
PLUthreshold	102, 213	
Pmax	108, 208	
PMOD		
COM ERR	243	
T OUT	243	
WDOG	243	
PMod24V	43	
Polarising pins		
External feedback connectors	30	
I/O Modules	23	
Neutral/phase connector	32	
Relay 1	24	
Watchdog relay	24	
Power	95, 234	
Power board 24V fail	211	
Power down	43	
Power modulation	187	
Power module	46, 88	
Enable	20	
Power Module 24V Failure	24	
PowerMod1Rev	88	
Pr	108, 208	
Pr/Ps alarm	109, 196, 210	
PrcValTfr	43	
PRE TEMP	243	
Preferred Master	65	
PreTemp	103	
PreTempHeatsink	101	
Preventive Maintenance	220	
Pri	196	
Primary	112	
Process Alarms	212	
Process Value Transfer active	213	
Profibus		
Pinout	27	
Specification	219	
Profinet IO Pinout	28	
Protection	215	
Protocol	65	
PRST	238	
Ps	108, 195, 205	
Ps over Pr	213	
Pt	108, 195, 208	
PU	238	
PU.AL	238	
PulseLen	82	
PulseScale	82	
Push pin	140	
Push to Back	134	
Function block context menu	131	
Wire context menu	133	
Pushbuttons	42	
PV	69	
Analogue input	61	
Analogue output	62	
Digital I/O	80	
Relay source	116	
Remote panel (PU)	238	
PV Transfer		
Alarm Acknowledge	76	
Alarm Detection	73	
Alarm Disable	72	
Alarm Latch	75	
Alarm Signalling	74	
Alarm Stop	77	
PV.AL (Remote panel)	238	
PV1 to PV3	70	
PWR indicator	43	
PWR'n'cal	44	
Pwr'n'EEProm	44	
Pwr'n'.Ribbon	44	
PwrModRev	44	
Pz	195	
PZMax	110, 195, 206	
Q		
Q	99	
QS Entry/Exit	43	
Quickstart		
Menu	45	
Modbus parameter addresses	182	
R		
r	195	
r.roc	242	
RampRate	118	
RangeHigh		
Analogue input	61	
Analogue output	62	
RangeLow		
Analogue input	61	
Analogue output	62	
RateDone	118	
Ready	66	
Recipes	244	
Red wiring editor items	135	
Redo	129	
Reduction factor	195	
Relay	116	
Modbus parameter addresses	165	
Specification	218	
Watchdog	24	
Relay 1	24	
Func	46, 47	
REM Beacon	231, 232	
Remote		
Panel connector	29	
Remote/Local switching	42	
Select	118	
Voltage sensing	31	
Remote 1 (2)	118	
Remove		
All items from this page	150	
Recipe parameter	147	
Selected item	150	
Rename Wiring Editor diagram	135	
Re-Route		

Wire	130, 132	Names	134
Wires	135	Show Wires Using Tags	130
Reset		Show/Hide grid	129
Counter	79	Signal wiring	
Energy counter	82	I/O modules	23
IP Monitor	90	Remote panel	227
Totaliser	121	Watchdog and Relay 1	24
Resolution		Single Row	149
Energy counter	83	Six delta wiring	38, 40
Totaliser	121	SK8	20
Return key	42	SK9	20
Revision level (Power module)	88	SmpHld	95
Ripple Carry	78	Snapshot	146
Rotating Incremental control	190	Soft Start/Stop	86
Rotating Incremental Distributed control	192	Software version	i
RotDisInc	106, 192	SP	69, 234
RotIncr	106, 190, 204	SP.SEL	234
Run	121	SP1 to SP3	70
RUN Beacon	231	Space Evenly	135
S		Specification	214
S	99	Communications	219
S1 to S4	112	Environment	215
Safety Earth	21	Input/output modules	
Safety notes	11, 223	Optional	218
Safety Ramp	86	Standard	216
Save Graphic	135	Power requirements	214
Save the current watch/recipe list	147	Relay	218
Sbr	242	SPSelect	118
Scan	127	SPTrack	118
Scan all device addresses	127	SPUnits	118
Scroll key	231	SPX Beacon	231
Scroll keys	42	Sqrt	95
Secondary	112	Standby	54, 68
Select		Status	92, 107
All	135	Control Diag	71
Language	87	Maths	95
Operation	95	Strategy Standby mode	54
Page	150	Strict	65
Selecting components	129	Sub	95
SelMax	95	Subnet 1 Mask	65
SelMin	95	Summary pages	
SELV	12	Alarm	53
Sensor Break detection	242	Power	52
Serial Num.	87	Supply frequency fault	24
Serial number	87	Supply power wiring	
Set 1	229	Driver unit	20
Set 2	230	Fuseing	20
Setpoint editing	234	Remote panel	226
Setpoint Select	234	Thyristor power units	30
SetProv		Switch PA	96
Menu	117	Symbols	224
Modbus parameter addresses	182, 183	System alarms	211
Remote panel configuration	244	T	
Setup		Tags	130, 132
Comms NetStatus	66	TapNb	112
Network	100	Target	79
Sharing	106	Target setpoint scaling	118
Algorithm	194	Task Break	132
Efficiency	193	Technical specification	214
Shedding Ability Factor	196	Temperature limits	215
ShedFactor	110, 196, 205	Temperature pre-Alarm	212
Show		Text	149
MAC	66	Thick wires	133

Three delta wiring	38, 39	User Page	148
Three star wiring	37, 40	Creation	148
Three-phase feedback	249	User Value	
Threshold	90	Menu	122
THYR SC	243	Modbus parameter addresses	184, 185
Thyr SC	103, 211	UsrEnergy	.82
Thyristor		UsrUnit	.82
Enable	20	V	
Short/open circuit	24	V Average	.99
Thyristor heatsink temperature	211	V, V2, V3	.99
Thyristor open circuit	211	V ²	.99
Thyristor short circuit	211	Burst	.99
TI	69, 70	Maxim	.99
Time	120	Value only	149
Time Above	90	Vdips	211
Timer		VdipsThreshold	24, 101, 211
Menu	119	VextScale	101
Modbus parameter addresses	183, 184	Vibration specification	215
TLF	43, 103, 212, 243	Vline Nominal	100, 101
Total		Vline, Vline2, Vline 3	.99
Channels	108	VloadNominal	100
Stations	108	Volt Dips	103, 243
Total Channels	207	Voltage sensing (remote)	.31
Total Load Failure (TLF) alarm	212, 243	VoltFault	103, 243
Total power demand	193	VRMS	234
Totaliser		W	
Menu	121	Watch/Recipe editor	146
Modbus parameter addresses	184	Adding parameters	146
TotalOut	121	Capture current values into a data set	147
TotalStation	207	Clear the selected data set	147
TotEnergy	82	Create a new empty data set	147
TotUnit	82	Create a new watch/recipe list	147
Trans Enable	68	Data set creation	146
Trans PV	69	Download the selected data set to the device	147
Transfer function active	71	Insert item ahead of selected item	147
Transfer Mode	46, 51	Move selected item	147
Transfer Span	69	Open an existing watch/recipe file	147
Trigger	120	Open OPC Scope	147
TrueGood/TrueBad	92	Remove recipe parameter	147
Type	112	Save the current watch/recipe list	147
Analogue input	61	Snapshot	147
Analogue output	62	Watchdog	44, 54
Digital I/O	80	Relay	.24
Timer	119	WindowChopOff	101
U		Wiring	
Undelete		Load	.30
Comment	133	Mains	
Function block context menu	131	Driver unit	.20
Monitor	134	Remote panel	226
Wire	133	Thyristor power unit	.30
Wiring editor items	135	Remote panel	226
UnderVoltThreshold	101, 212	Signal	.22
Undo	129	Remote panel	227
Unit over temperature	24	Software	132
UnitID Enable	65	Colours	133
UNITS	238	Context Menu	132
Units (Totaliser)	121	Thick wires	133
Unlink		Wiring examples	.37
Comment	133	Working setpoint	234
Monitor	134	WorkingSP	118
Up arrow key	42, 231	WSP	234
Upscale	95		
Use Tags	132		

X

XOR 91, 93

Z

Z, Z2, Z3 99

Zoom 129

Zref, Zref2, Zref3 102

Eurotherm: International sales and support www.eurotherm.com

Contact Information

Eurotherm Head Office

Faraday Close,
Durrington,
Worthing, West Sussex,
BN13 3PL

Sales Enquiries

T +44 (0)1903 695888
F 0845 130 9936

General Enquiries

T +44 (0)1903 268500
F 0845 265982

Worldwide Offices

www.eurotherm.com/worldwide



Scan for local contacts

Represented by:

© Copyright Eurotherm Limited 2015

Eurotherm by Schneider Electric, the Eurotherm logo, Chessell, EurothermSuite, Mini8, Eyon, Eyris, EPower, EPack, nanodac, piccolo, versadac, optivis, Foxboro and Wonderware are trademarks of Schneider Electric, its subsidiaries and affiliates. All other brands may be trademarks of their respective owners.

All rights are strictly reserved. No part of this document may be reproduced, modified or transmitted in any form by any means, neither may it be stored in a retrieval system other than for the purpose to act as an aid in operating the equipment to which the document relates, without the prior written permission of Eurotherm Limited.

Eurotherm Limited pursues a policy of continuous development and product improvement. The specifications in this document may therefore be changed without notice. The information in this document is given in good faith, but is intended for guidance only. Eurotherm Limited will accept no responsibility for any losses arising from errors in this document.