



MOTORTRONICS™

Solid State AC Motor Control

VMX-Synergy Plus™

IEC - USER MANUAL

200 - 600V, 17 - 850 Amps



- Removable 3.5" Color Touch Screen rated IP66/N4X
- 42 Smart Application profiles - easy setup in 1 minute
- Auto Pedestal to control spinning motors
- Built-in iERS – intelligent Energy Recovery System
- Advanced motor protection with memory
- Life Time Event Logging Diagnostics
- Metering for power, voltage and current
- Integral Bypass



Contents

| | |
|--|-----------|
| 1. Safety | 5 |
| 1.1 Important information | 5 |
| 2. Mechanical Installation | 7 |
| 2.1 Mounting | 7 |
| 2.2 Requirements for an Enclosure | 7 |
| 2.3 Enclosure Ventilation | 7 |
| 2.4 Enclosure Internal Clearances | 8 |
| 2.5 Model Number Description | 9 |
| 2.6 Altitude and Temperature De-rate | 9 |
| 2.7 Dimensions | 10 |
| 2.7.1 VMX-SGY-I-17 to VMX-SGY-I-100 (Size 1) | 10 |
| 2.7.2 VMX-SGY-I-132 to VMX-SGY-I-195 (Size 2) | 10 |
| 2.7.3. VMX-SGY-I-242 to VMX-SGY-I-361 (Size 3) | 11 |
| 2.7.4 VMX-SGY-I-430 to VMX-SGY-I-500 (Size 3) | 11 |
| 2.7.5 VMX-SGY-I-625 to VMX-SGY-I-850 (Size 4) | 12 |
| 2.8 Environmental Data | 13 |
| 2.9 Key to External Features | 14 |
| 3. Electrical Installation | 15 |
| 3.1 Warnings | 15 |
| 3.1 Terminal Layout | 16 |
| 3.2 Terminal Descriptions | 17 |
| 3.3 Control Supply and Control Circuit (Us and Uc) | 18 |
| 3.4 Supply Connections | 19 |
| 3.5 Control Wiring | 20 |
| 3.5.1 Three Wire Control | 20 |
| 3.5.2 User Programmable Control | 21 |
| 3.5.3 Reversing Configuration | 22 |
| 3.5.4 Sequential Soft Start Diagram | 23 |
| 4. Ratings and Technical Information | 24 |
| 4.1 Rating Table | 24 |
| 4.2 EN 60947-4-2 Product Information | 25 |
| 4.3 Sizing Guide | 26 |
| 4.3.1 In-Line Connection | 26 |
| 4.3.2 In-Delta Connection | 27 |
| 4.4 Short Circuit Protection | 28 |
| 4.5 Electronic Overload Relay | 29 |
| 4.6 Conductor Size and Torque Requirements | 30 |
| 5. Operation | 31 |

- 5.1 Configuration and Parameters 31
 - 5.1.1 Features 31
- 5.2 On Screen Menus 32
- 5.3 Auto Setup Example 33
- 5.4 Auto-Setup Parameter Settings 34
- 5.5 Auto Reset Function 36
 - 5.5.1 Mapping Auto Reset Status to Digital Outputs 38
 - 5.5.2 Two-Wire, Three-Wire and Communications Control 39
 - 5.5.3 Control Supply Loss 39
 - 5.5.4 Modbus/Communications 39
 - 5.5.5 Overload Trip 39
 - 5.5.6 Remote Start on Trip 39
 - 5.5.7 Hand/Auto 39
- 5.6 Auto Reset Timing Diagrams 40
 - Fig 5.6.1: Auto Reset - Two Wire -Three Phase Supply Loss 40
 - Fig 5.6.2 Auto Reset - Two Wire - Control Supply Loss 41
 - Fig 5.6.3 Auto Reset - Three Wire - Three Phase Supply Loss 42
 - Fig 5.6.4 Auto Reset - Three Wire - Control Supply Loss 43
 - Fig 5.6.5 Auto Reset - Two Wire – Overload 44
- 5.7 Parameters for Touchscreen Interface 45
 - 5.7.1 ‘Advanced’ Category 45
 - 5.7.2 ‘Input/Output’ (I/O) Category 49
 - 5.7.3 ‘Monitor’ Category 51
 - 5.7.4 ‘Log’ Category 52
 - 5.7.5 ‘Device’ Category 54
- 5.8 Auto Setup Menu 55
- 5.9 Advanced Menu 57
- 5.10 Input/Output Menu 81
- 5.11 Monitor Menu 87
- 5.12 Log Menu 95
- 5.13 Device Menu 113
- 5.14 Functional Summaries 118
 - 5.14.1 Automatic Settings 118
 - 5.14.2 Low Current Protection 119
 - 5.14.3 Current Limit 119
 - 5.14.4 Shearpin 120
- 5.15 Touchscreen Menu Paths 121
 - 5.15.1 Advanced Menu 121
 - 5.15.2 Input / output Menu 124

| | |
|---|------------|
| 5.15.3 Monitor | 125 |
| 5.15.4 Log Menu | 126 |
| 6 Trip and Fault Codes | 127 |
| 6.1 Trip Code Descriptions | 127 |
| 6.2 Fail-Safe Codes | 131 |
| 6.2.1 Main Board Trip Operation 2 (2402 – 2436) | 131 |
| 6.2.2 Logging Operation 2 Trip (2601 – 2603) | 132 |
| 7 Communication | 133 |
| 7.1 Modbus RTU Serial Communications..... | 133 |
| 7.1.1 Modbus RTU Connection | 133 |
| 7.1.2 Modbus Communications Configuration | 134 |
| 7.1.3 Message Structure for RTU Mode | 135 |
| 7.1.4 Supported Functions..... | 135 |
| Read Holding Registers | 136 |
| Write Single Register | 136 |
| Write Multiple Registers | 137 |
| Memory Map | 137 |
| Message Timing | 138 |
| 7.2 Modbus Register Address Aliasing..... | 139 |
| Appendix 1 | 142 |
| A1.0 Updating VMX-Synergy Plus™ Firmware | 142 |
| A1.1 Updating VMX-Synergy Plus™ Keypad Firmware..... | 143 |
| Appendix 2 | 144 |
| A2.0 Remote Installation of the Touchscreen | 144 |

Safety

1. Safety

1.1 Important information

Installers should read and understand the instructions in this guide prior to installing, operating and maintaining the soft start. The following symbols may appear in this guide or on the soft start to warn of potential hazards or to draw attention to certain information.

Dangerous Voltage



Indicates the presence of a hazardous voltage which could result in personal injury or death.

Tension dangereuse

Indique la présence d'une tension dangereuse qui peut entraîner des blessures ou la mort.

Warning/Caution



Indicates a potential hazard. Any instructions that follow this symbol should be obeyed to avoid possible damage to the equipment, and personal injury or death.

Avertissement/Mise en garde

Indique un danger potentiel. Toutes les instructions suivant ce symbole doivent être observées, afin d'éviter les dommages de l'équipement et les blessures ou la mort.

Protective Earth (Ground)



Indicates a terminal which is intended for connection to an external conductor for protection against electric shock in case of a fault.

Mise à la terre (Masse)

Indique une borne dont l'usage prévu est d'être connecter à conducteur externe pour assurer la protection contre les chocs électriques en cas de défauts.

Caution Statements

The examples and diagrams in this manual are included solely for illustrative purposes. The information contained in this manual is subject to change at any time and without prior notice. In no event will responsibility or liability be accepted for direct, indirect or consequential damages resulting from the use or application of this equipment.

Mises en garde

Les exemples et les schémas de ce manuel ne sont donnés qu'à titre illustratif. Les informations présentées dans ce manuel peuvent être modifiées sans avis préalable. En aucun cas nous n'assumons la responsabilité ou l'obligation pour les dommages directs, indirects ou consécutifs qui résultent de l'utilisation ou application de cet équipement.

Short Circuit

Motortronics soft starts are not short circuit proof. After severe overload or short circuit, the operation of the soft start should be fully tested by an authorised service agent.

Court-circuit

Les démarreurs progressifs Motortronics Une sont pas à l'épreuve des courts-circuits. Après une forte surcharge ou un court-circuit, le fonctionnement du démarreur progressif doit être intégralement vérifié par un agent de maintenance agréé.

Safety



VMX-Synergy™ Plus soft starts contain dangerous voltages when connected to the mains supply. Only qualified personnel that have been completely trained and authorised, should carry out installation, operation and maintenance of this equipment.

Les démarreurs progressifs VMX-Synergy™ Plus contiennent des tensions dangereuses, lorsqu'ils sont connectés à la tension secteur. Les activités d'installation, d'utilisation et d'entretien de cet équipement doivent être effectuées par un personnel qualifié, dûment formé et habilité.

Installation of the soft start must be made in accordance with existing local and national electrical codes and regulations and have a minimum protection rating.

Le démarreur progressif doit être installer conformément au code local et nationale d'électricité et à la réglementation en vigueur, et il doit avoir un indice de protection minimal.

It is the responsibility of the installer to provide suitable grounding and branch circuit protection in accordance with local electrical safety codes.

Il appartient à l'installateur d'assurer la mise à la terre et la protection du circuit de branchement, conformément au code de sécurité électrique local.

This soft start contains no serviceable or re-usable parts.

Ce démarreur progressif ne contient pas de pièces réparables ou réutilisables

The STOP function of the soft start does not isolate dangerous voltages from the output of the soft start. An approved electrical isolation device must be used to disconnect the soft start from the incoming supply before accessing electrical connections.

La fonction STOP du démarreur progressif n'isole pas les tension dangereuses en sortie du démarreur progressif. Avant d'accéder aux raccordement électriques, il faut utiliser un dispositif d'isolation électrique approuvé pour déconnecter le démarreur progressif de la tension d'entrée.

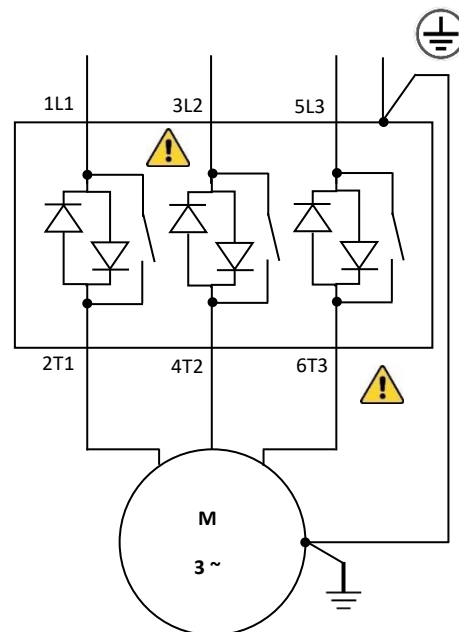

Installation

2. Mechanical Installation

2.1 Mounting

The unit must be fixed to a flat, vertical surface using the mounting holes (or slots) on its base-plate. The mechanical outline diagrams give the dimensions and mounting hole positions for each model. Ensure that:

- The orientation of the unit has the 'TOP' uppermost.
- The location allows adequate front access.
- You can view the touchscreen.
- Do not install other equipment that generates significant heat close to the soft starter.

2.2 Requirements for an Enclosure

For a typical industrial environment, an enclosure would provide the following:

- A single location for the unit and its protection/isolation switchgear
- The safe termination of cabling and/or busbars

Means to effect proper air flow through the enclosure.

2.3 Enclosure Ventilation

When fitting VMX-Synergy™ Plus into a cabinet, ventilation must be provided if the heat output of the unit is greater than the cabinet will dissipate. Use the following formula to determine the fan requirement. An allowance has been incorporated into the formula so that the figure for Q is the air delivery in the fan suppliers' data.

Heat dissipated can be approximated with the formulas:

Starting

Watts (VMX-Synergy Plus™) = start current(A) x start time(s) x number of starts per hour/1200

iERs Disabled

Watts (VMX-Synergy Plus™) = (VMX-Synergy Plus™ current rating) x 0.6

iERs Enabled

The maximum power dissipation occurs when energy saving and the iERS is turned on

Watts (VMX-Synergy Plus™) = (VMX-Synergy Plus™ current rating) x 1.5

$$Q = \frac{4 \times Wt}{(T_{max} - T_{amb})}$$

Where:

Q = volume of air (cubic metres per hour-m³/h)

Wt = Heat produced by the unit and all other heat sources within the enclosure (Watts)

T_{max} = Maximum permissible temperature within the enclosure (50°C for a fully rated VMX-Synergy Plus™)

T_{amb} = Temperature of the air entering the enclosure (°C).

If CFM is preferred, substitute °F for °C. Q is now in CFM

Installation

2.4 Enclosure Internal Clearances

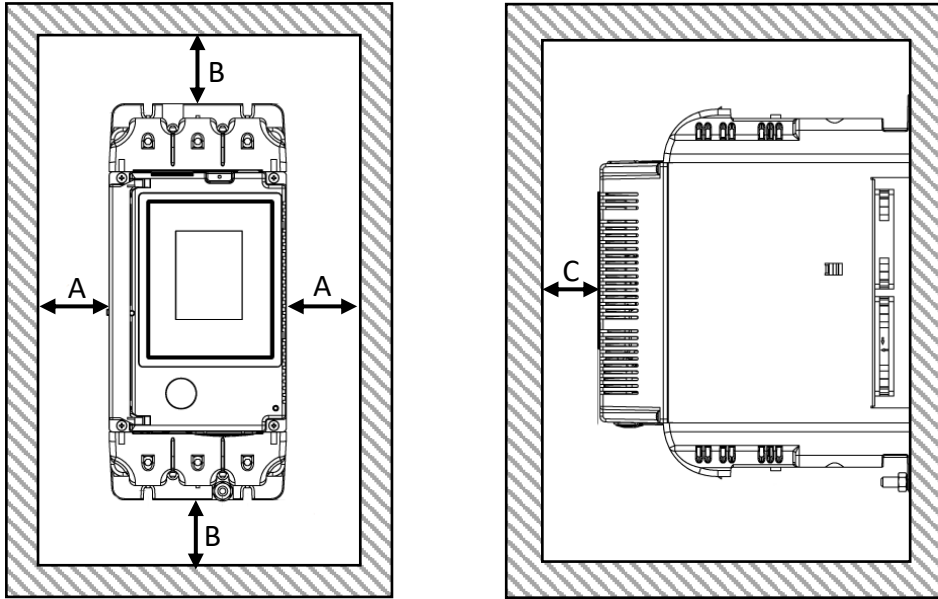

| Model | A | | B | | C | |
|--------------------------------|-----|------|-----|------|----|------|
| | mm | inch | mm | inch | mm | inch |
| VMX-SGY-I-17 to VMX-SGY-I-100 | 25 | 0.98 | 75 | 2.95 | 25 | 0.98 |
| VMX-SGY-I-132 to VMX-SGY-I-195 | 40 | 1.57 | 100 | 3.93 | 25 | 0.98 |
| VMX-SGY-I-242 to VMX-SGY-I-500 | 60 | 2.36 | 125 | 4.92 | 25 | 0.98 |
| VMX-SGY-I-625 to VMX-SGY-I-850 | 100 | 3.94 | 250 | 9.84 | 25 | 0.98 |

Installation

2.5 Model Number Description

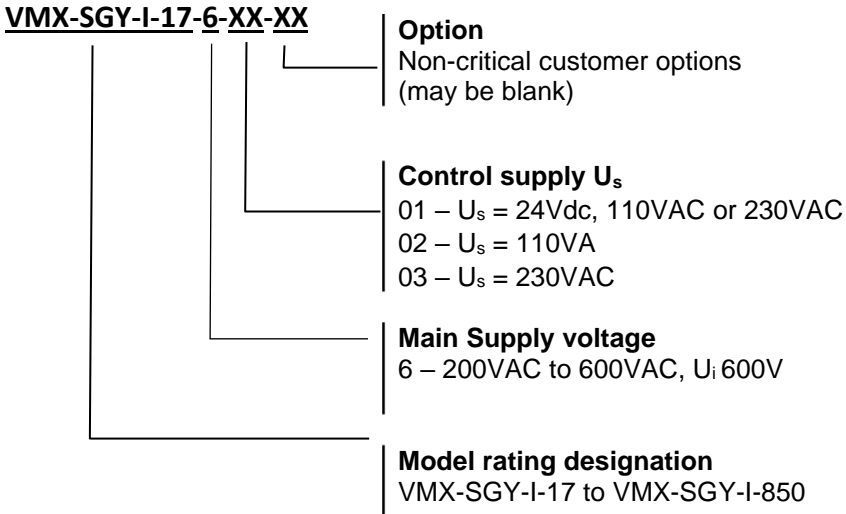

2.6 Altitude and Temperature De-rate



VMX-SGY-I-17 to VMX-SGY-I-500

-20°C (-4°F) to 50°C (122°F). Above 50°C (122°F) de-rate linearly by 4 % of VMX-Synergy Plus I_e per °C to a maximum of 60°C (140°F).

VMX-SGY-I-625 to VMX-SGY-I-850

-20°C (-4°F) to 40°C (104°F). Above 40°C (104°F) de-rate linearly by 2 % of VMX-Synergy Plus I_e per °C to a maximum of 60°C (140°F)



Altitude above sea level 1000m (3281ft). Above 1000m (3281ft) de rate by 1% of VMX-Synergy Plus I_e per 100m (328ft) to a maximum altitude of 2000m (6562ft).

Installation

2.7 Dimensions

2.7.1 VMX-SGY-I-17 to VMX-SGY-I-100 (Size 1)

Dimensions

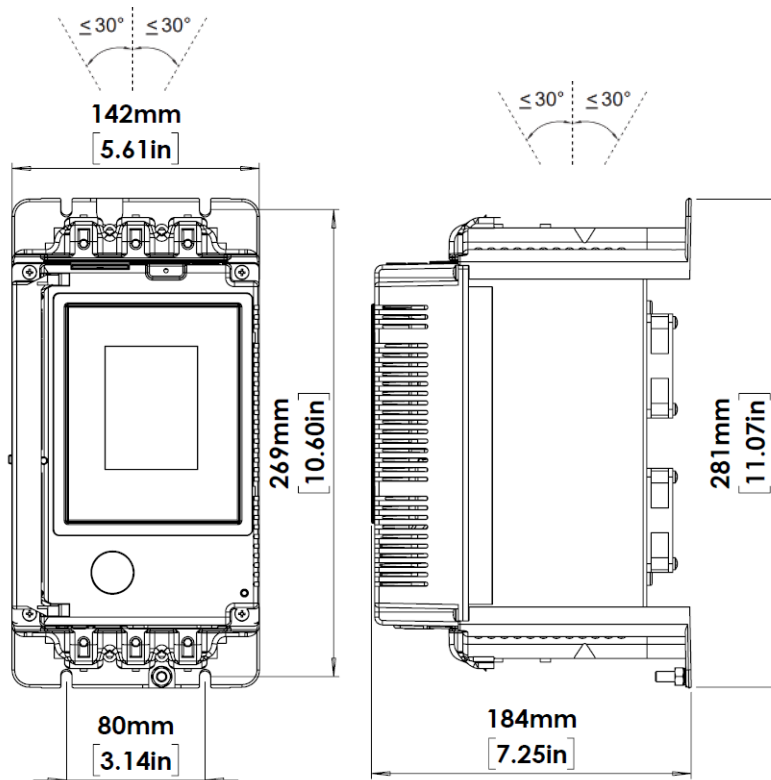

VMX-SGY-I-17 to VMX-SGY-I-29
Weight = 3.9 kg (8.6 lbs)

VMX-SGY-I-35 to VMX-SGY-I-100
Weight = 4.2 kg (9.26 lbs)

2.7.2 VMX-SGY-I-132 to VMX-SGY-I-195 (Size 2)

Dimensions

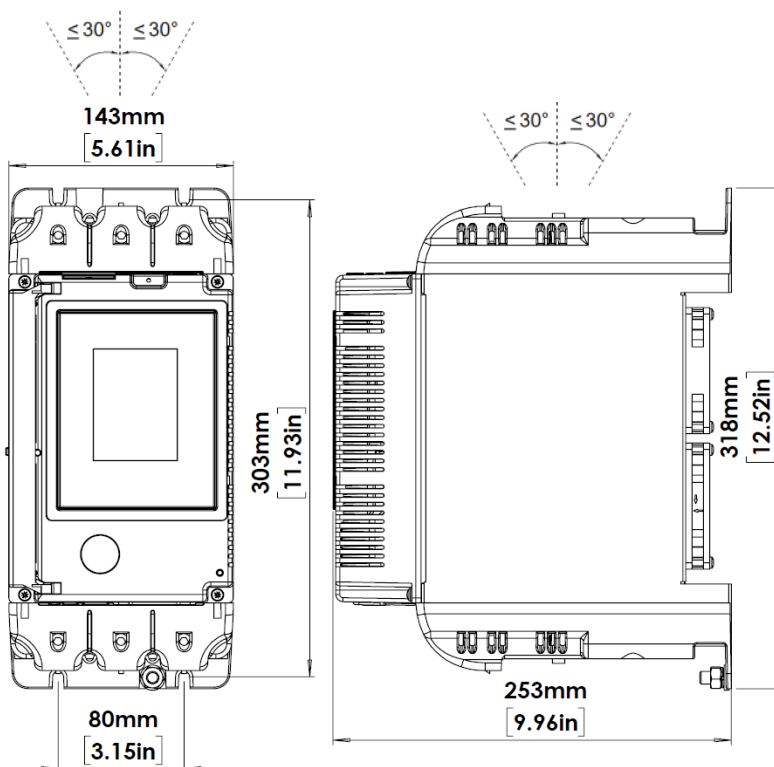

VMX-SGY-I-132
Weight = 6.7 kg (14.78 lbs)

VMX-SGY-I-160 to VMX-SGY-I-195
Weight = 7.0 kg (15.44 lbs)

Installation

2.7.3. VMX-SGY-I-242 to VMX-SGY-I-361 (Size 3)

Dimensions

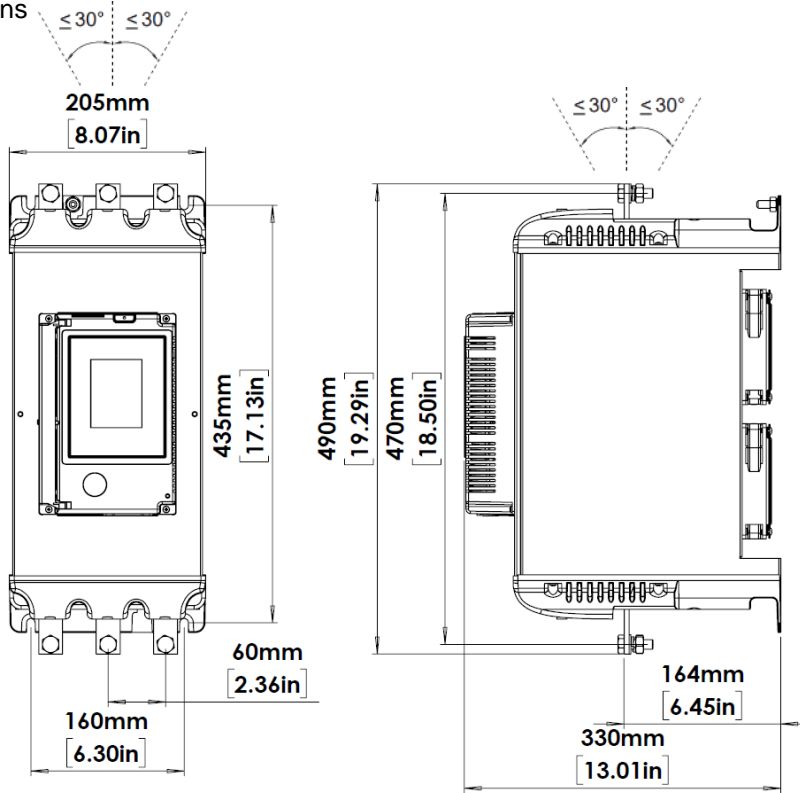

VMX-SGY-I-242 to VMX-SGY-I-361
Weight = 17.0 kg (37.5 lbs)

2.7.4 VMX-SGY-I-430 to VMX-SGY-I-500 (Size 3)

Dimensions

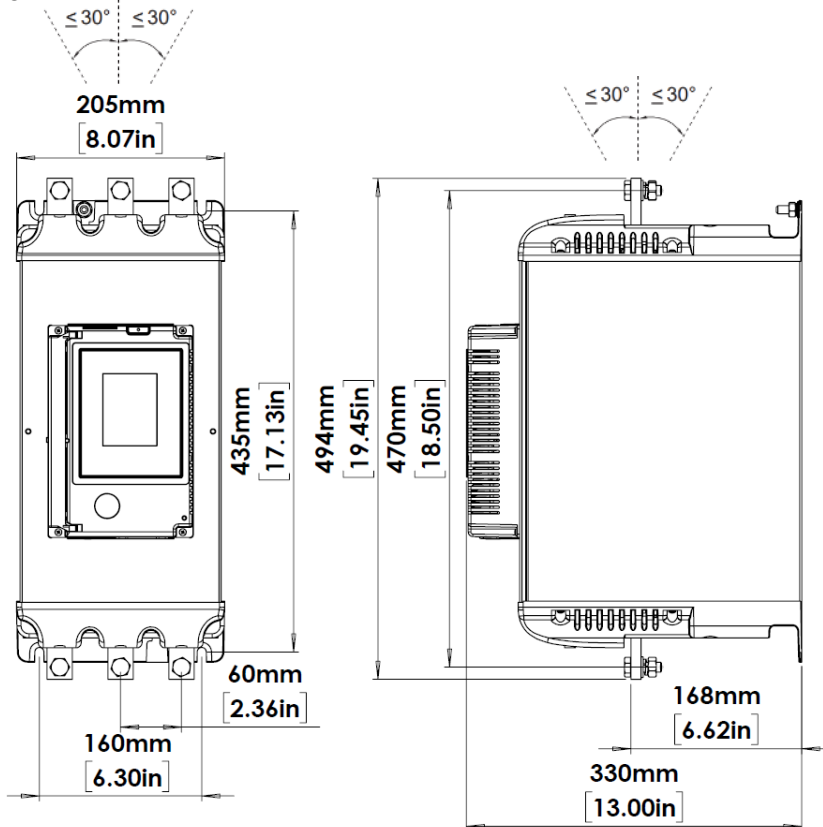

VMX-SGY-I-430 to VMX-SGY-I-500
Weight = 22 kg (48.5 lbs)

Installation

2.7.5 VMX-SGY-I-625 to VMX-SGY-I-850 (Size 4)

Dimensions

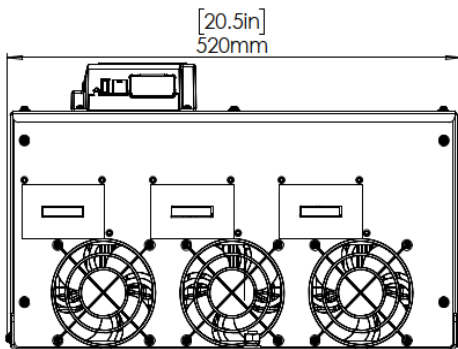
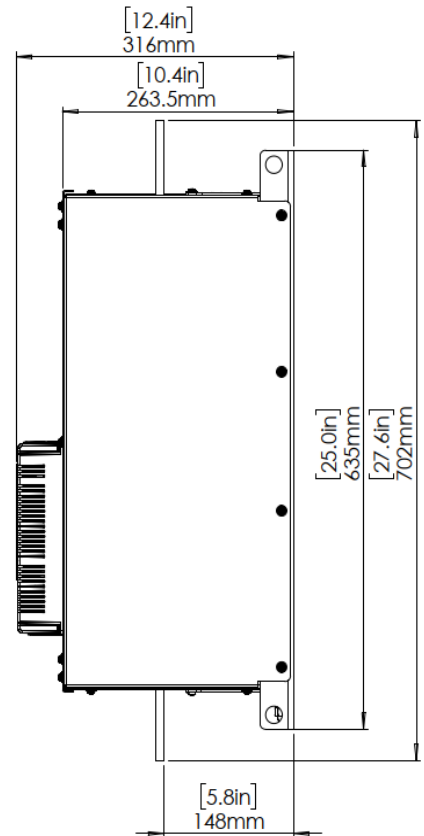
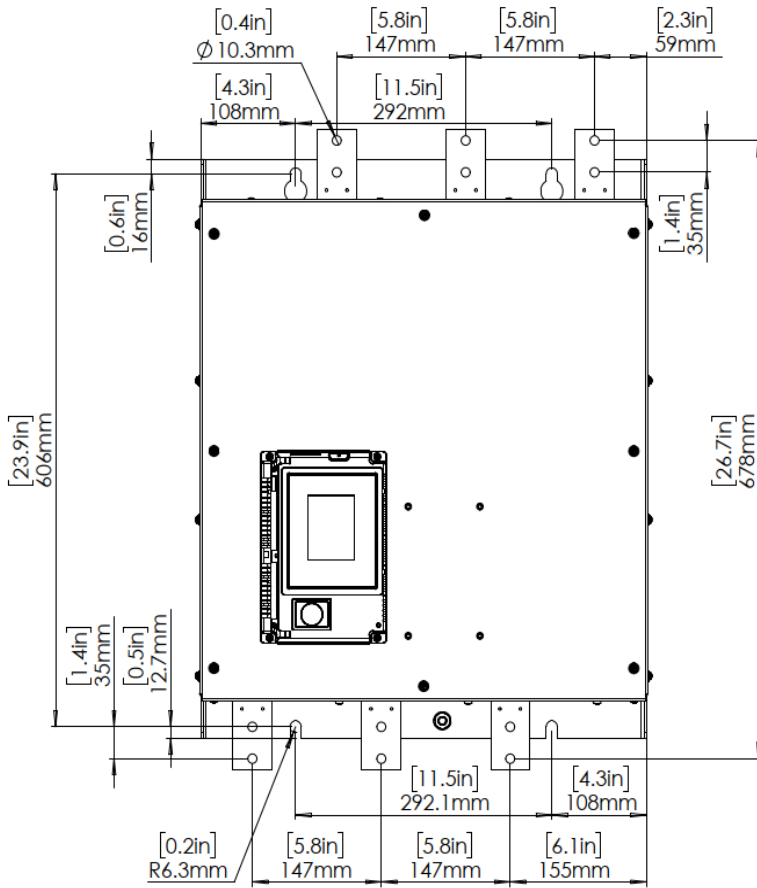

VMX-SGY-I-625 to VMX-SGY-I-850
Weight = 54 kg (119 lbs)

Installation

2.8 Environmental Data

| | | | | | | | | | | | |
|--|---|-------------|------------|-------------|------------|------------|-------------|------------|--|------------|------------|
| Model (VMX-SGY-I-) | 17 | 22 | 29 | 35 | 41 | 55 | 66 | 80 | 100 | | |
| Frame Size | 1 | | | | | | | | | | |
| Heat output @ FLC (W) | 25.5 | 33 | 43.5 | 52.5 | 61.5 | 82.5 | 99 | 120 | 150 | | |
| Weight kg [lb] | 3.9 [8.6] | | | 4.2 [9.26] | | | | | | | |
| Model (VMX-SGY-I-) | 132 | 160 | 195 | 242 | 302 | 361 | 430 | 500 | 625 | 722 | 850 |
| Frame Size | 2 | | | 3 | | | | 4 | | | |
| Heat output @ FLC (W) | 198 | 240 | 293 | 363 | 453 | 542 | 645 | 750 | 938 | 1083 | 1275 |
| Weight kg [lb] | 6.7 [14.78] | 7.0 [15.44] | | 17.0 [37.5] | | | 22.0 [48.5] | | 54.0 [119.0] | | |
| Model (VMX-SGY-I-) | 17 to 500 | | | | | | | | 625 to 850 | | |
| Ambient Operating Temp. | -20°C [-4°F] to 50°C [122°F]; above 50°C derate linearly by 4% of VMX-Synergy Plus™ I _e per °C to a maximum of 60°C (140°F) | | | | | | | | -20°C [-4°F] to 40°C [104°F]; above 40°C derate linearly by 2% of VMX-Synergy Plus™ I _e per °C to a maximum of 60°C (140°F) | | |
| Transportation and Storage Temperature | -25°C to 70°C [-13°F to 158°F] continuous | | | | | | | | | | |
| Humidity | Max 85% non-condensing, not exceeding 50% @ 40°C [104°F] | | | | | | | | | | |
| Maximum Altitude | 1,000m [3281ft]; above 1000m derate by 1% of VMX-Synergy Plus™ I _e per 100m (328ft) to a maximum altitude of 2,000m (6562ft) | | | | | | | | | | |
| Environmental Rating | Main Circuit: IP00 (IP20 with optional finger guards for sizes 1&2 only); Control Circuit: IP20; No corrosive gases permitted | | | | | | | | | | |

Installation

2.9 Key to External Features

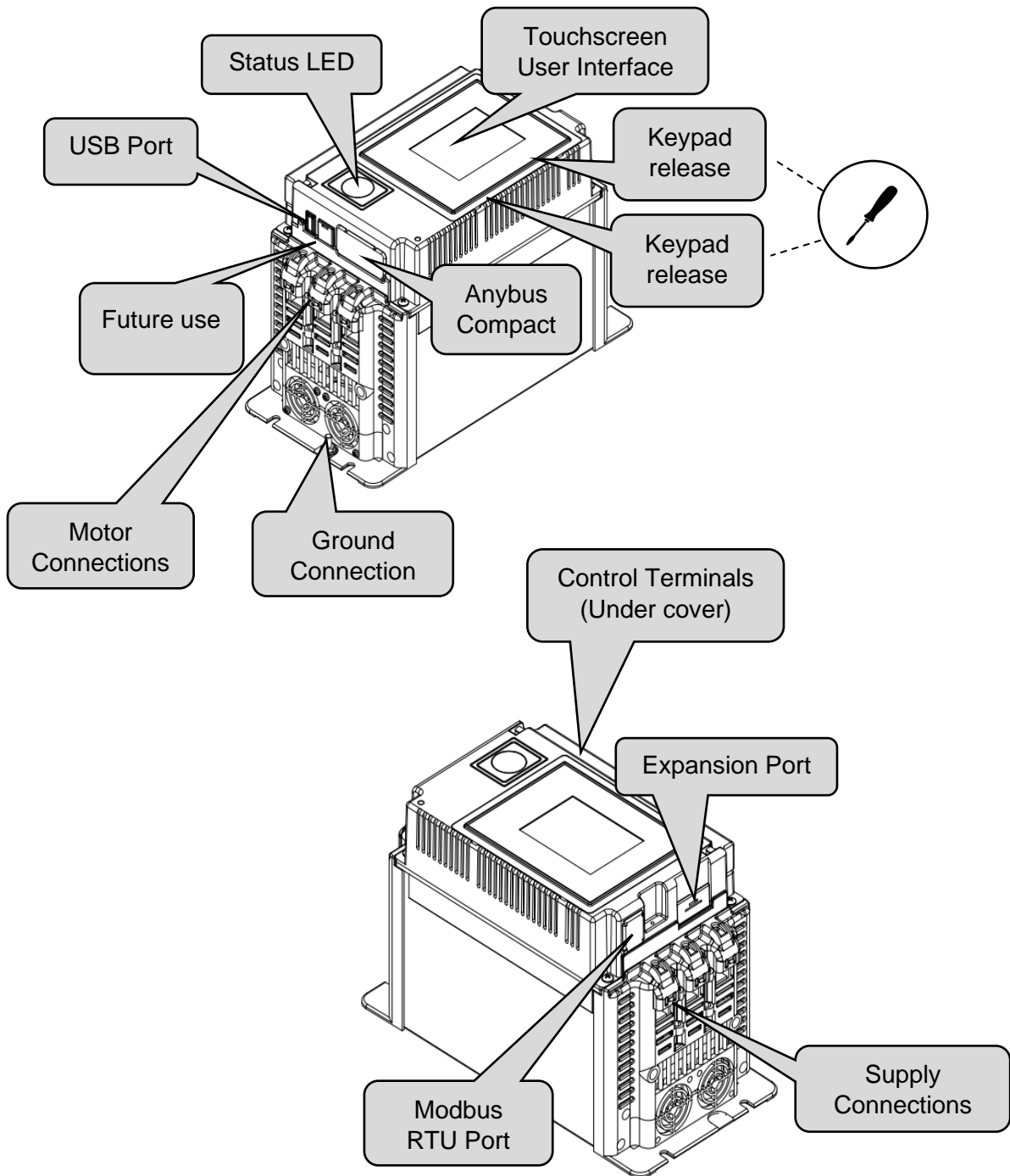

Installation

3. Electrical Installation

3.1 Warnings



Isolation

Caution: VMX-Synergy Plus™ uses semiconductor devices in the main circuit and is not designed to provide isolation. For this reason, isolation means must be installed in the supply circuit in accordance with the appropriate wiring and safety regulations.



Electrical Control Supply Requirements

All electrical connections are made to power input and output terminals, control terminals and an earth stud.



Access

No user accessible internal parts.



Fuse Protection

The Mains Supply and the Control Supply each require protection. Although all VMX-Synergy Plus™ units have electronic overload protection for the Soft Start, the installer should always fit fuses or circuit breakers, between the unit and the Mains Supply, not between the unit and the motor. Semiconductor fuses can be supplied as an option for short-circuit protection of the semiconductors. It is the responsibility of the installer and system designer/specifier to ensure that the required standards or regulations are complied with.



Safety

VMX-Synergy Plus™ soft starters contain hazardous voltages when connected to the electrical power supply. Only qualified personnel who are trained and authorized should carry out installation, operation and maintenance of this equipment. Refer to and carefully follow all of the 'Warnings' section at the start of this user manual, as well as other warnings and notes throughout the manual.

Installation

3.1 Terminal Layout

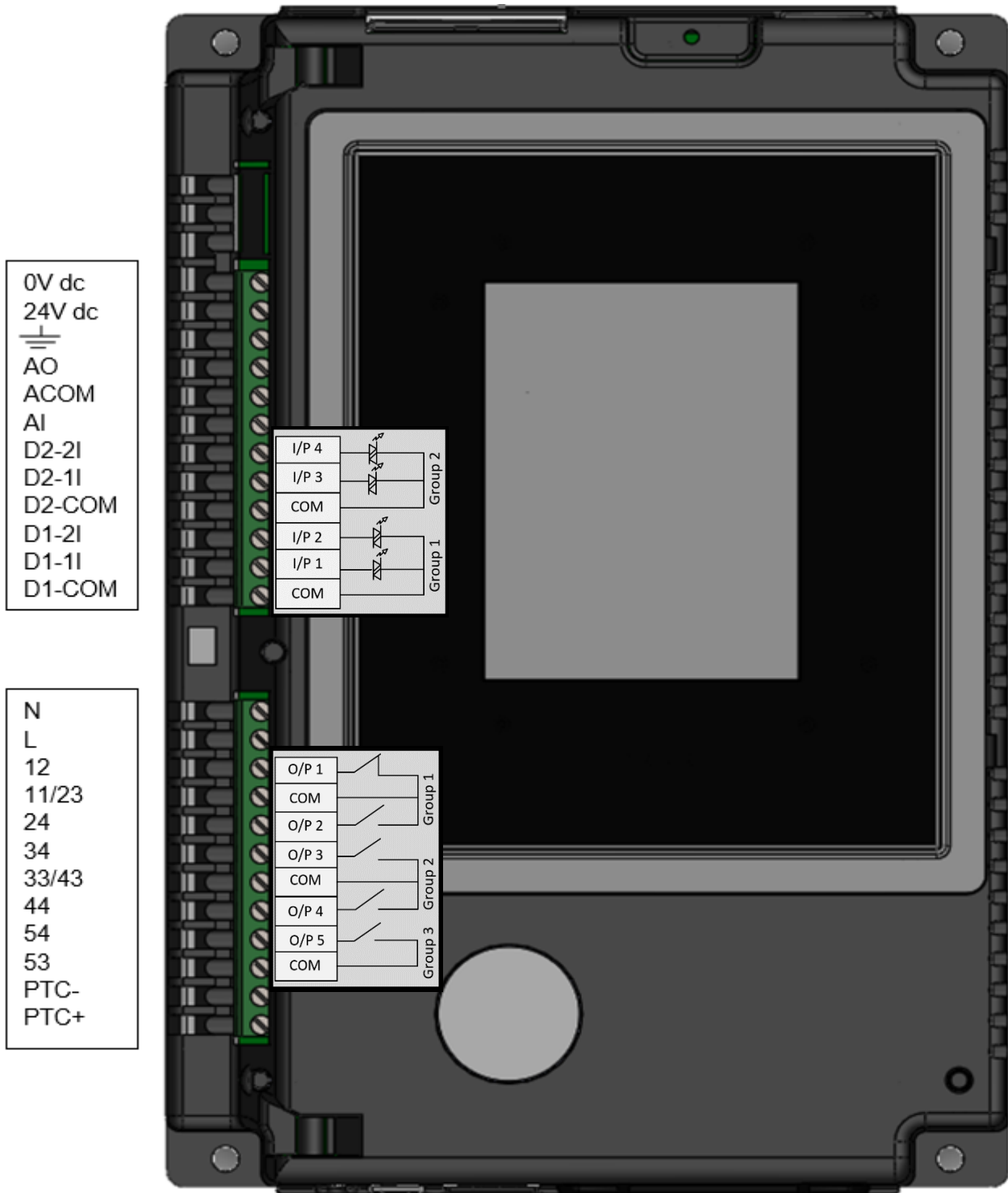

Installation

3.2 Terminal Descriptions

| Terminal Name | Description | Programmable | Default | Rating | Notes |
|---|--------------------------------------|-----------------|--------------|-----------------|-------|
| 0V dc | Control Supply | | | See Table 1, Us | #3 |
| 24V dc | | | | | |
|  | Signal ground | | | | |
| AO | Analog Output | 0-10V or 4-20mA | | | |
| ACOM | Analog Common | | | | |
| AI | Analog Input | 0-10V or 4-20mA | | | |
| D2-2I | Digital Input 4 - Group 2 | See Table 1, Uc | None | | #2 |
| D2-1I | Digital Input 3 - Group 2 | See Table 1, Uc | Reset | | #2 |
| D2-COM | Digital Input - Group 2 Common | | | | #2 |
| DI-2I | Digital Input 2 - Group 1 | See Table 1, Uc | None | | #1 |
| DI-1I | Digital Input 1 - Group 1 | See Table 1, Uc | Start / Stop | | #1 |
| D1-COM | Digital Input - Group 1 Common | | | | #1 |
| N | Control supply | | | See Table 1, Us | #3 |
| L | | | | | |
| 12 | Digital Output 1 - Group 1 relay N/C | Yes | Fault | 230VAC 1A AC15 | |
| 11 / 23 | Digital Output - Group 1 Common | | | | |
| 24 | Digital Output 2 - Group 1 relay N/O | Yes | Fault | 230VAC 1A AC15 | |
| 34 | Digital Output 3 - Group 2 relay N/O | Yes | Running | 230VAC 1A AC15 | |
| 33 / 43 | Digital Output - Group 2 Common | | | | |
| 44 | Digital Output 4 - Group 2 relay N/O | Yes | End of Start | 230VAC 1A AC15 | |
| 54 | Digital Output 5 - Group 3 relay N/O | Yes | Running | 230VAC 3A AC15 | |
| 53 | Digital Output 5 - Group 3 Common | | | | |
| PTC- | 3 x PTC in series (130°C) | | | | |
| PTC+ | 3 x PTC in series (130 °C) | | | | |

| | |
|----|--|
| #1 | The programmed digital input setting on D1-COM, D1-1I, D1-2I must correspond to the voltage applied to these terminals to avoid risk of damage to the equipment. Afin d'éviter d'endommager l'équipement, le réglage de l'entrée numérique programmé sur D1-COM, D1-1I, D1-2I doit correspondre à la tension appliquée à ces bornes. |
| #2 | The programmed digital input setting on D2-COM, D2-1I, D2-2I must correspond to the voltage applied to these terminals to avoid risk of damage to the equipment. Afin d'éviter d'endommager l'équipement, le réglage de l'entrée numérique programmé sur D2-COM, D2-1I, D2-2I doit correspondre à la tension appliquée à ces bornes. |
| #3 | The control supply can be 110 to 230Vac applied to the N, L terminals or 24Vdc applied to the 0Vdc, 24V input terminals. The correct voltage as specified must only be applied to one of these supply inputs to avoid risk of damage to the equipment. L'alimentation contrôle peut être 110 à 230 Vca, appliquée aux bornes N et L, ou 24 Vcc, appliquée aux bornes d'entrée de 0 Vcc, 24 V. Afin d'éviter d'endommager l'équipement, la tension appropriée selon les indications ne doit être appliquée qu'à une entrée d'alimentation. |

Installation

3.3 Control Supply and Control Circuit (Us and Uc)

Table 1: Interface control Voltages, 2A supply (continuous)

| Model No (s) | Us (+10% -15%) | Uc (+10% -15%) | Notes |
|--|---------------------|---|---|
| VMX-SGY-I-17-6-01 to VMX-SGY-I-361-6-01 | 110-230Vac or 24Vdc | 110Vac or 230Vac or 24Vdc 230Vac factory default. 230Vac défaut d'usine | The system can have either a 110/230Vac mains or 24Vdc input NOT both. Le système peut avoir soit une alimentation principale de 110/230Vac ou de 24 Vdc, mais en aucun cas les deux simultanément |
| VMX-SGY-I-430-6-02 to VMX-SGY-I-850-6-02 | 110Vac | | |
| VMX-SGY-I-430-6-03 to VMX-SGY-I-850-6-03 | 230Vac | | |

Power consumption

| Model No (s) | Power consumption |
|---------------------------------|-------------------|
| VMX-SGY-I-17 to VMX-SGY-I-361 | 60VA |
| VMX-SGY-I-430 to VMX-SGY-I-500 | 120VA |
| VMX-SGY-I-625 to VMX-SGY-I -850 | 180VA |

24Vdc supply specification

| Model No (s) | Power consumption |
|-------------------------------|--|
| VMX-SGY-I-17 to VMX-SGY-I-361 | 24Vdc 60W. Residual ripple 100mV. Spikes/switching peaks 240mV. Turn On/Off no overshoot of V out. Overvoltage protection output voltage must be clamped to <30Vdc |

Installation

3.4 Supply Connections

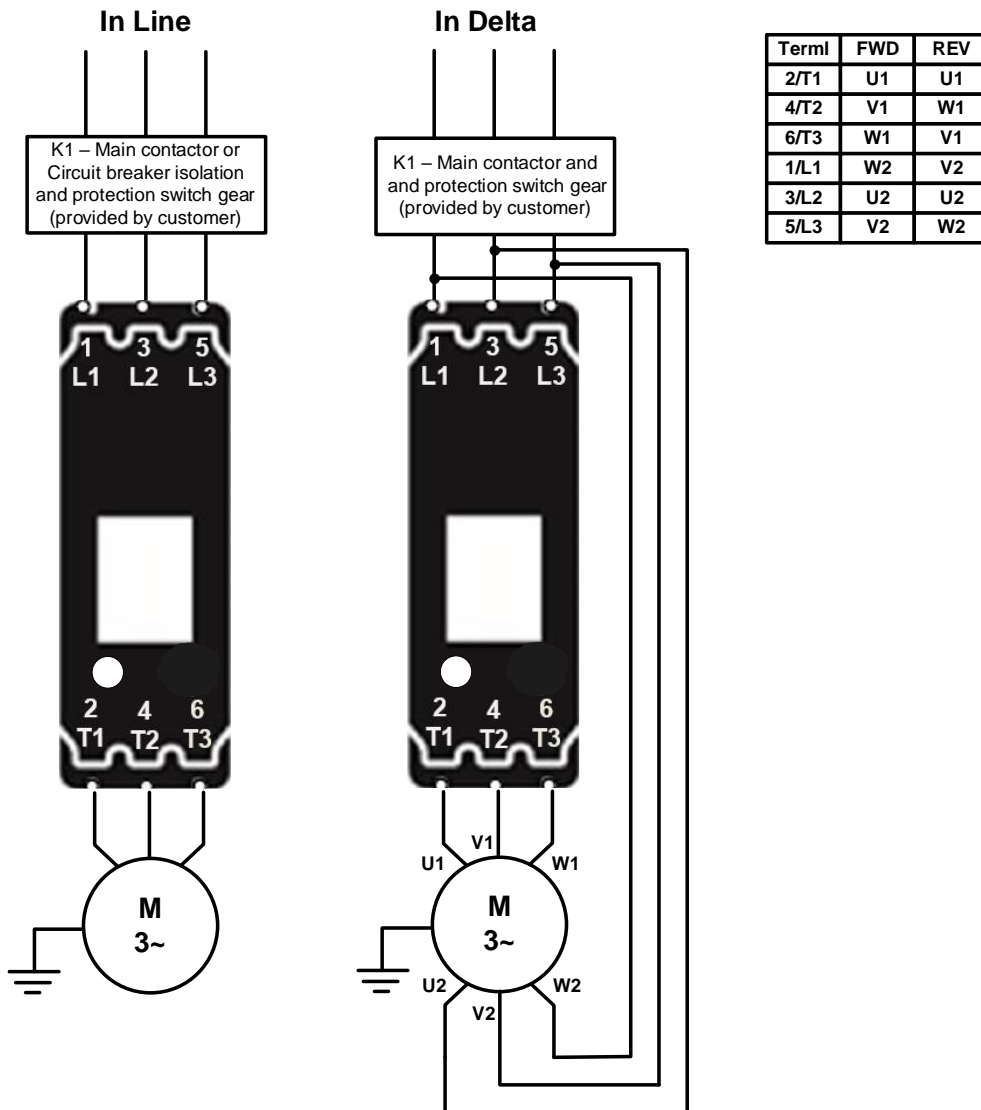

| | | | |
|---|--|---|--|
| <p>⚠ For suitable short circuit protection devices (SCPD's) see short Circuit Protection in the Technical Information/ standards section of this guide.</p> <p>Pour un dispositif de protection approprié contre le court-circuit, voir la protection contre le court-circuit dans la section « Informations techniques/normes » du présent guide.</p> | <p>⚠ For wire size and torque requirements see Technical Information/ standards section of this guide.</p> <p>Pour les dimensions de câble et les besoins en couple, voir la section « Informations techniques/normes » du présent guide.</p> | <p>⚠ In Delta For this configuration applying the equation.</p> <p>$VMX\text{-Synergy Plus } I_e = I_e (\text{motor}) / \sqrt{3}$</p> <p>Allows lower current rating VMX-Synergy Plus than the motor.</p> <p>The contactor K1 can also be connected inside the delta circuit.</p> <p>When connected in the delta $K1 \text{ current rating} = I_e (\text{motor}) / \sqrt{3}$</p> | <p>⚠ En Delta Pour cette configuration, appliquer l'équation suivante:</p> <p>$VMX\text{-Synergy Plus } I_e = I_e (\text{moteur}) / \sqrt{3}$</p> <p>Cela permet le courant nominal inférieur de VMX-Synergy Plus par rapport au moteur.</p> |
|---|--|---|--|

Installation

3.5 Control Wiring



The programmed digital input settings for D1COM, D1-1I, D1-2I, and D2COM, D2-1I, D2-1I must correspond to the voltage applied to these terminals to avoid risk of damage to the equipment.



The control supply can be 110 to 230Vac applied to the N, L terminals or 24Vdc applied to the 0Vdc, 24V input terminals. The correct voltage as specified must only be applied to one of these supply inputs to avoid risk of damage to the equipment.

3.5.1 Three Wire Control

3 Wire Control Diagram

110/230Vac control supply (U_s) and digital input (U_c) programming.

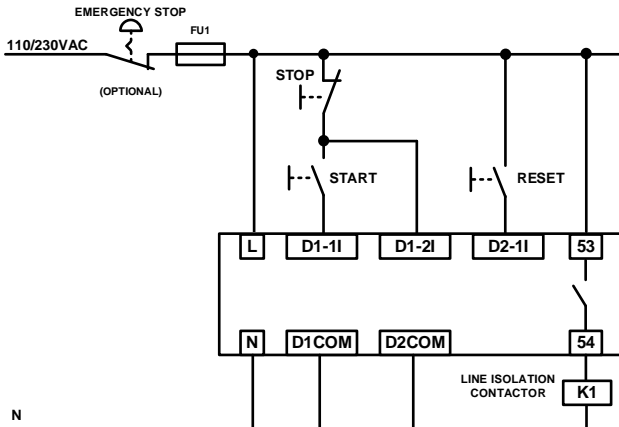

3 Wire Control Diagram

24Vdc control supply (U_s) and digital input (U_c) programming.
(VMX-SGY-I-17 to VMX-SGY-I-361)

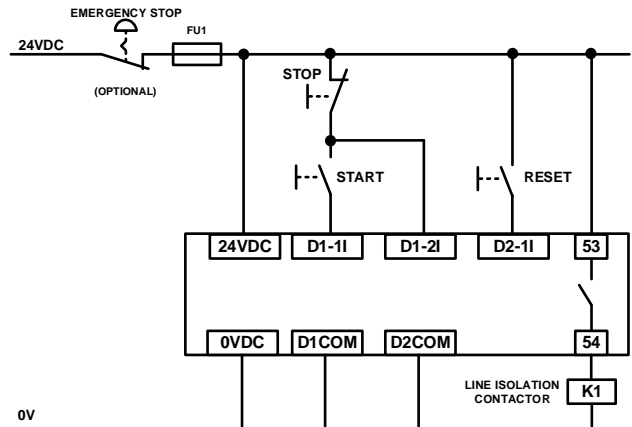

| CAUTION | |
|----------------|--|
| #1 | <p>REFER to TABLE 1 for input control voltages. These recommended wiring diagrams are specifically where the control supply voltage (U_s) is identical to the control circuit voltage (U_c) and not to be supplied separately. Other wiring configurations must also be in accordance with existing local and national codes and regulations.</p> <p>RÉFÉRER au TABLEU 1 à la page 12 pour des tensions de contrôle d'entrée. Ces schémas de câblage sont recommandées spécifiquement lorsque la tension d'alimentation de commande (U_s) est identique à la tension du circuit de commande (U_c). U_s et U_c ne doivent pas être alimentés séparément. Toutes les configurations de câblage doivent également être en conformité avec les codes et les règlements locaux et nationaux en vigueur.</p> |
| #2 | <p>Power factor correction capacitors must NOT be positioned between the soft start and the motor or there is a risk of damaging thyristors due to current peaks.</p> <p>Condensateurs de correction de facteur de puissance NE doivent pas être placés entre le moteur et le démarreur progressif ou il y a un risqué d'endommager les thyristors en raison des pics de courant.</p> |

Installation

3.5.2 User Programmable Control

110/230Vac (US) and (UC) user programmable control diagram

24Vdc (US) and (UC) user programmable control diagram (VMX-SGY-I-17 to VMX-SGY-I-361)

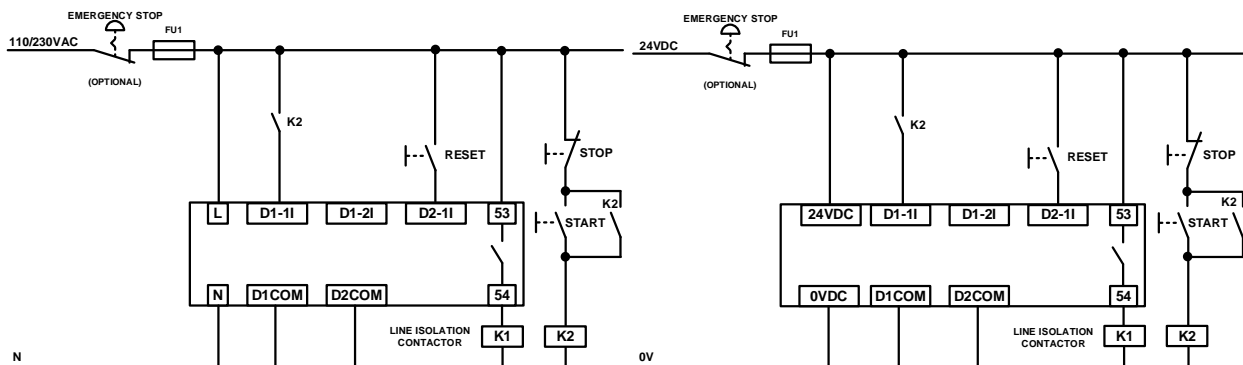

| User programmable inputs are full programmable | |
|---|---|
| D1 – 1I = High Start / Low Stop | 1) Optional high reset. If this reset is required ensure “User Programmable” is selected in the control method menu found in the Digital Inputs menu. If you would prefer the reset to work by removing and reapplying the Start Signal on D1 - 1I then select “Two wire control” in the control method menu. |
| D1 – 2I = None | |
| D2 – 1I = High Reset | |

Installation

3.5.3 Reversing Configuration

Soft start reversing circuit without soft stop, it shows the main components required. You must follow your local wiring and electrical regulations when constructing this circuit, set to 'User Programmable' control.

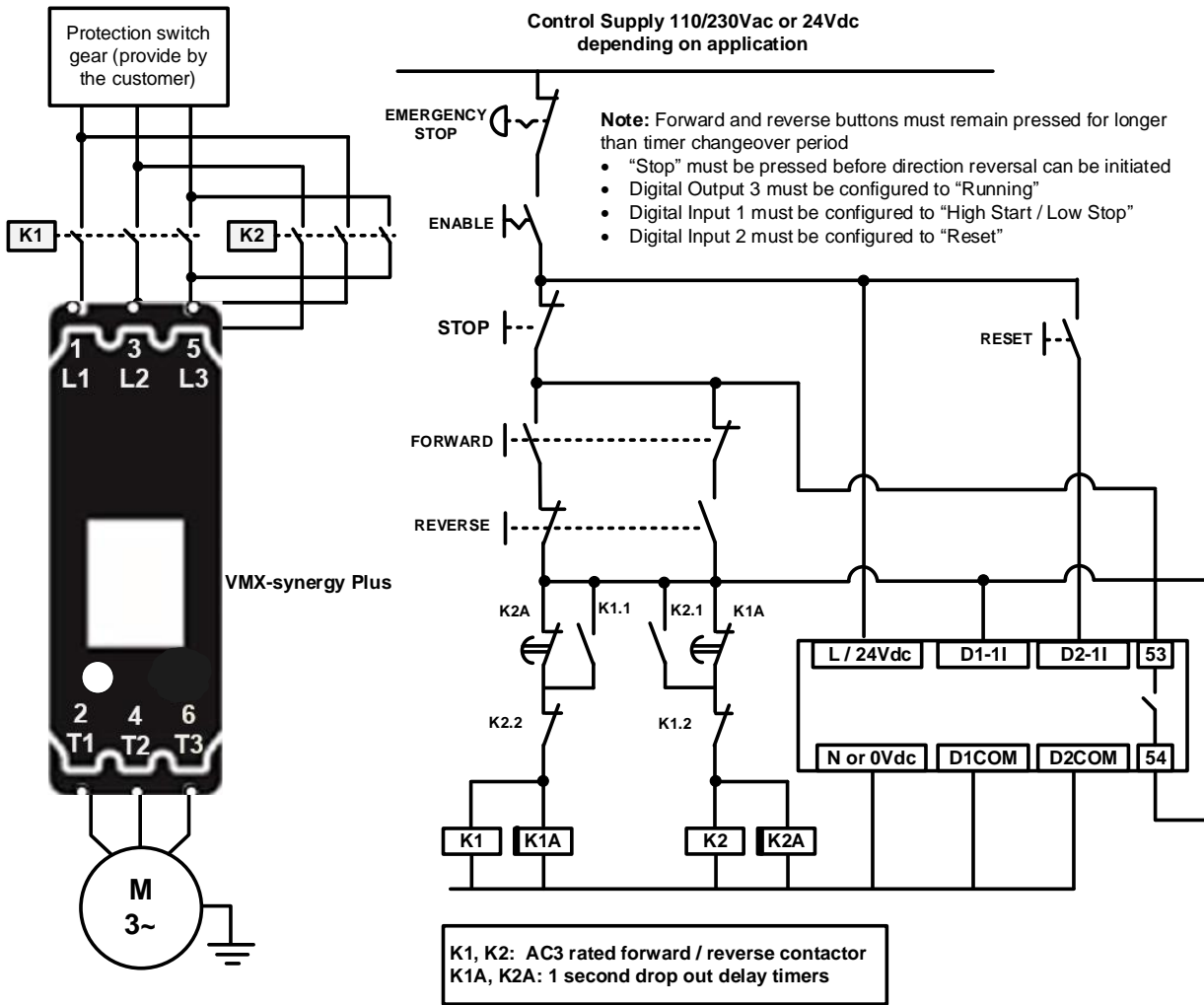

These are the major components of the system. Local wiring regulations should be observed. Note the use of timers to ensure that a reversed voltage is not applied to the starter/motor before the motor field has had some chance to reduce to zero. The thermal capabilities of VMX-Synergy™ should be considered.

Installation

3.5.4 Sequential Soft Start Diagram

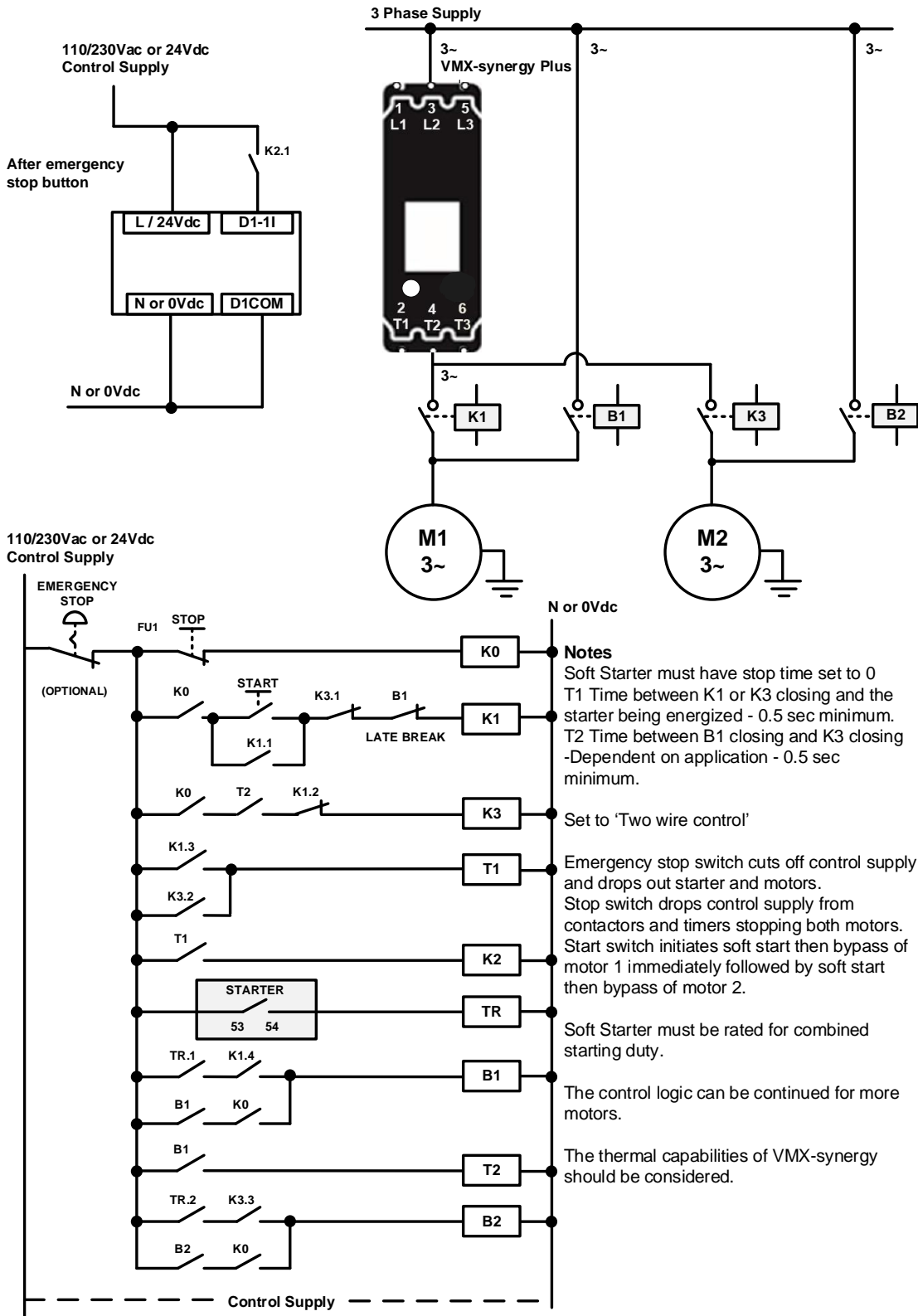

CAUTION

REFER to Section 3.2 for input control voltage.

RÉFÉRER au Section 3.2 pour des tensions de contrôle d'entrée

Installation

4. Ratings and Technical Information

4.1 Rating Table

Minimum current ratings based on typical rated operation currents of motors for the corresponding rated operational powers.

Current rating optimised for kW@500V & HP@550-600V - Ref IEC 60947-4-1 Table G.1 where applicable.

Size 1,2 and 3

| Type | I _e A ³⁾ | kW ¹⁾ | | | FLA A ³⁾ | HP ²⁾ | | | | | U _s |
|--------------------|-----------------------------------|------------------|------|------|------------------------|------------------|------|----------|----------|----------|----------------------------------|
| | | 230V | 400V | 500V | | 200V | 208V | 220-240V | 440-480V | 550-600V | |
| VMX-SGY-I-17-6-01 | 17 | 4 | 7.5 | 7.5 | 17 | 3 | 5 | 5 | 10 | 15 | 24VDC, 110VAC to 230VAC |
| VMX-SGY-I-22-6-01 | 22 | 5.5 | 11 | 11 | 22 | 5 | 5 | 5 | 15 | 20 | |
| VMX-SGY-I-29-6-01 | 29 | 7.5 | 15 | 15 | 27 | 7.5 | 7.5 | 7.5 | 20 | 25 | |
| VMX-SGY-I-35-6-01 | 35 | 7.5 | 18.5 | 22 | 34 | 10 | 10 | 10 | 25 | 30 | |
| VMX-SGY-I-41-6-01 | 41 | 11 | 22 | 22 | 41 | 10 | 10 | 10 | 30 | 40 | |
| VMX-SGY-I-55-6-01 | 55 | 15 | 30 | 37 | 52 | 15 | 15 | 15 | 40 | 50 | |
| VMX-SGY-I-66-6-01 | 66 | 18.5 | 37 | 45 | 65 | 20 | 20 | 20 | 50 | 60 | |
| VMX-SGY-I-80-6-01 | 80 | 22 | 45 | 55 | 77 | 20 | 25 | 25 | 60 | 75 | |
| VMX-SGY-I-100-6-01 | 100 | 30 | 55 | 55 | 99 | 30 | 30 | 30 | 75 | 100 | |
| VMX-SGY-I-132-6-01 | 132 | 37 | 75 | 90 | 125 | 40 | 40 | 40 | 100 | 125 | |
| VMX-SGY-I-160-6-01 | 160 | 45 | 90 | 110 | 156 | 50 | 50 | 60 | 125 | 150 | |
| VMX-SGY-I-195-6-01 | 195 | 55 | 110 | 132 | 192 | 60 | 60 | 75 | 150 | 200 | |
| VMX-SGY-I-242-6-01 | 242 | 75 | 132 | 160 | 242 | 75 | 75 | 75 | 200 | 250 | |
| VMX-SGY-I-302-6-01 | 302 | 90 | 160 | 200 | 302 | 100 | 100 | 100 | 250 | 300 | |
| VMX-SGY-I-361-6-01 | 361 | 110 | 200 | 250 | 361 | 125 | 125 | 150 | 300 | 350 | |
| VMX-SGY-I-430-6-02 | 430 | 132 | 250 | 250 | 414 | 150 | 150 | 150 | 350 | 450 | 110VAC |
| VMX-SGY-I-500-6-02 | 500 | 150 | 280 | 355 | 477 | 150 | 150 | 150 | 400 | 500 | 230VAC |
| VMX-SGY-I-430-6-03 | 430 | 132 | 250 | 250 | 414 | 150 | 150 | 150 | 350 | 450 | |
| VMX-SGY-I-500-6-03 | 500 | 150 | 280 | 355 | 480 | 150 | 150 | 200 | 400 | 500 | |

Size 4

| Type | I _e A ⁴⁾ | kW ¹⁾ | | | FLA A ⁴⁾ | Hp ²⁾ | | | | | U _s |
|--------------------|-----------------------------------|------------------|------|------|------------------------|------------------|------|----------|----------|----------|----------------|
| | | 230V | 400V | 500V | | 200V | 208V | 220-240V | 440-480V | 550-600V | |
| VMX-SGY-I-625-6-02 | 625 | 200 | 355 | 425 | 625 | 200 | 200 | 250 | 500 | 600 | 110VAC |
| VMX-SGY-I-722-6-02 | 722 | 220 | 400 | 530 | 722 | 250 | 250 | 300 | 600 | 700 | |
| VMX-SGY-I-850-6-02 | 850 | 280 | 500 | 630 | 850 | 300 | 300 | 350 | 700 | 800 | |
| VMX-SGY-I-625-6-03 | 625 | 200 | 355 | 425 | 625 | 200 | 200 | 250 | 500 | 600 | 230VAC |
| VMX-SGY-I-722-6-03 | 722 | 220 | 400 | 530 | 722 | 250 | 250 | 300 | 600 | 700 | |
| VMX-SGY-I-850-6-03 | 850 | 280 | 500 | 630 | 850 | 300 | 300 | 350 | 700 | 800 | |

- 1) Rated operational powers in kW as per IEC 60072-1 (primary series) corresponding to IEC current rating.
- 2) Rated operational powers in HP corresponding to FLA current rating according to UL508 and Table 430.250 of the National Electrical Code.
- 3) The I_e and FLA rating applies for a maximum surrounding air temperature of 50°C. Above 50°C de-rate linearly by 4% of I_e or FLA per °C to a maximum of 60°C.
- 4) The I_e and FLA rating applies for a maximum surrounding air temperature of 40°C. Above 40°C de-rate linearly by 2% of I_e or FLA per °C to a maximum of 60°C.

Installation

4.2 EN 60947-4-2 Product Information

| | | | | |
|---|---------------------------------|--|--|--|
| Rated operational voltages | U_e | 200VAC to 600VAC | | |
| Rated operational currents | I_e | See Rating Table | | |
| Rating index | | See Sizing Guide | | |
| Rated frequency | | 50 - 60Hz \pm 5Hz | | |
| Rated duty | | Uninterrupted. | | |
| Form designation | | Form 1, Internally Bypassed | | |
| Rated insulation voltage | U_i | 600V | | |
| Rated impulse withstand voltage | U_{imp} | Main circuit | 6kV | |
| IP code | | Main circuit | IP00 (IP 20 optional on VMX-SGY-I-17 to VMX-SGY-I-195) | |
| | | Supply and Control circuit | IP20 | |
| Pollution Degree | | 3 | | |
| Rated conditional short-circuit current and type of co-ordination with associated short circuit protective device (SCPD) | | Type 1 co-ordination See Short Circuit Protection Tables for rated conditional short-circuit current and required current rating and characteristics of the associated SCPD | | |
| Rated control circuit voltage (programmable) | U_c | 24VDC, 110VAC or 230VAC | | 50 - 60Hz \pm 5Hz Protect with UL listed fuse rated max.4A. |
| Rated control supply voltage | U_s | See Rating Table, 2 Amp supply (cont.) | | |
| Relay specification | 11/23, 12, 24 and 33/43, 34, 44 | AC-15, 230VAC, 1A DC-13 30VDC, 0.7A | | |
| | 53, 54 | AC-15, 250VAC, 3A DC-13 24VDC, 2A | | |
| Electronic Overload relay with manual reset | Trip Class | 10, 20 or 30 (See Sizing Guide for associated I_e rating) | | |
| | Current setting | 10% I_e to I_e | | |
| | Rated frequency | 50 to 60Hz \pm 5Hz | | |
| | Time-current characteristics | See Fig.1 for trip curves (Trip time $T_p \pm 20\%$) | | |
| EMC Emission levels | EN 55011 | Class A ⓘ | | |
| EMC Immunity levels | IEC 61000-4-2 | 8kV/air discharge or 4kV/contact discharge | | |
| | IEC 61000-4-3 | 10 V/m | | |
| | IEC 61000-4-4 | 2kV/5kHz (main and power ports) | | |
| | | 1kV/5kHz (signal ports) | | |
| | IEC 61000-4-5 | 2kV line-to-ground 1kV line-to-line | | |
| IEC 61000-4-6 | 10V | | | |
| The safety functions were not evaluated by UL. | | | | |
| Transient surge suppression shall be installed on the line side of this equipment and shall be rated 600_V (phase to phase), suitable for overvoltage category III, and shall provide protection for a rated impulse withstand voltage peak of 6 kV” – or equivalent. | | | | |
| The control circuits are to be supplied by class 2, limited voltage current or protected by a 4A UL 248 listed fuse. | | | | |
| Control and auxiliary circuits have an overvoltage withstand capacity of 2.5kV | | | | |
| ⓘ NOTICE: This product has been designed for environment A. Use of this product in environment B may cause unwanted electromagnetic disturbances, in which case the user may be required to take adequate mitigation measures | | | | |

Installation

4.3 Sizing Guide

4.3.1 In-Line Connection

Use tables to determine the size of the VMX-SGY-I required for the motor selected

Size 1 and 2

| I _e A | kW | | | FLA A | Hp | | | | | Trip Class 10 | Trip Class 20 | Trip Class 30 |
|---------------------|------|------|------|----------|------|------|----------|----------|----------|--|--|--|
| | 230V | 400V | 500V | | 200V | 208V | 220-240V | 440-480V | 550-600V | I _e : AC-53a: 3.5-17: 90-5 VMX- | I _e : AC-53a: 4-19: 90-5 VMX- | I _e : AC-53a: 4-29: 90-5 VMX- |
| 17 | 4 | 7.5 | 7.5 | 17 | 3 | 5 | 5 | 10 | 15 | SGY-I-17 | SGY-I-22 | SGY-I-29 |
| 22 | 5.5 | 11 | 11 | 22 | 5 | 5 | 5 | 15 | 20 | SGY-I-22 | SGY-I-29 | SGY-I-35 |
| 29 | 7.5 | 15 | 15 | 27 | 7.5 | 7.5 | 7.5 | 20 | 25 | SGY-I-29 | SGY-I-35 | SGY-I-41 |
| 35 | 7.5 | 18.5 | 22 | 34 | 10 | 10 | 10 | 25 | 30 | SGY-I-35 | SGY-I-41 | SGY-I-55 |
| 41 | 11 | 22 | 22 | 41 | 10 | 10 | 10 | 30 | 40 | SGY-I-41 | SGY-I-55 | SGY-I-66 |
| 55 | 15 | 30 | 37 | 52 | 15 | 15 | 15 | 40 | 50 | SGY-I-55 | SGY-I-66 | SGY-I-80 |
| 66 | 18.5 | 37 | 45 | 65 | 20 | 20 | 20 | 50 | 60 | SGY-I-66 | SGY-I-80 | SGY-I-100 |
| 80 | 22 | 45 | 55 | 77 | 20 | 25 | 25 | 60 | 75 | SGY-I-80 | SGY-I-100 | SGY-I-132 |
| 100 | 30 | 55 | 55 | 99 | 30 | 30 | 30 | 75 | 100 | SGY-I-100 | SGY-I-132 | SGY-I-160 |
| 132 | 37 | 75 | 90 | 125 | 40 | 40 | 40 | 100 | 125 | SGY-I-132 | SGY-I-160 | SGY-I-195 |
| 160 | 45 | 90 | 110 | 156 | 50 | 50 | 60 | 125 | 150 | SGY-I-160 | SGY-I-195 | See Size 3 |
| 195 | 55 | 110 | 132 | 192 | 60 | 60 | 75 | 150 | 200 | SGY-I-195 | See Size 3 | See Size 3 |

Size 3 and 4

| I _e A | kW | | | FLA A | Hp | | | | | Trip Class 10 | Trip Class 20 | Trip Class 30 |
|---------------------|------|------|------|----------|------|------|----------|----------|----------|--|--|--|
| | 230V | 400V | 500V | | 200V | 208V | 220-240V | 440-480V | 550-600V | I _e : AC-53a: 3.5-17: 90-3 VMX- | I _e : AC-53a: 4-19: 90-3 VMX- | I _e : AC-53a: 4-29: 90-3 VMX- |
| 160 | 45 | 90 | 110 | 156 | 50 | 50 | 60 | 125 | 150 | See Size 2 | See Size 2 | SGY-I-242 |
| 195 | 55 | 110 | 132 | 192 | 60 | 60 | 75 | 150 | 200 | See Size 2 | SGY-I-242 | SGY-I-302 |
| 242 | 75 | 132 | 160 | 242 | 75 | 75 | 75 | 200 | 250 | SGY-I-242 | SGY-I-302 | SGY-I-361 |
| 302 | 90 | 160 | 200 | 302 | 100 | 100 | 100 | 250 | 300 | SGY-I-302 | SGY-I-361 | SGY-I-430 |
| 361 | 110 | 200 | 250 | 361 | 125 | 125 | 150 | 300 | 350 | SGY-I-361 | SGY-I-430 | SGY-I-500 |
| 430 | 132 | 250 | 250 | 414 | 150 | 150 | 150 | 350 | 450 | SGY-I-430 | SGY-I-500 | SGY-I-625 |
| 500 | 150 | 280 | 355 | 480 | 150 | 150 | 150 | 400 | 500 | SGY-I-500 | SGY-I-625 | SGY-I-722 |
| 625 | 200 | 355 | 425 | 625 | 200 | 200 | 250 | 500 | 600 | SGY-I-625 | SGY-I-722 | SGY-I-850 |
| 722 | 220 | 400 | 530 | 722 | 250 | 250 | 300 | 600 | 700 | SGY-I-722 | SGY-I-850 | - |
| 850 | 280 | 500 | 630 | 850 | 300 | 300 | 350 | 700 | 800 | SGY-I-850 | - | - |

Installation

Sizing Guide (continued)

4.3.2 In-Delta Connection

Use tables to determine the size of the VMX-SGY-I required for the motor selected

Size 1 and 2

| I _e ¹⁾ | kW | | | FLA ¹⁾ | Hp | | | | | Trip Class 10 I _e : AC-53a: 3.5-17: 90-5 VMX- | Trip Class 20 I _e : AC-53a: 4-19: 90-5 VMX- | Trip Class 30 I _e : AC-53a: 4-29: 90-5 VMX- |
|------------------------------|------|------|------|-------------------|------|-----|------|------|--------------|--|--|--|
| | A | 230V | 400V | | 500V | A | 200V | 208V | 220- 240V | | | |
| 29 | 7.5 | 15 | 18.5 | 29 | 7.5 | 7.5 | 10 | 20 | 25 | SGY-I-17 | SGY-I-22 | SGY-I-29 |
| 38 | 11 | 18.5 | 22 | 38 | 10 | 10 | 10 | 25 | 30 | SGY-I-22 | SGY-I-29 | SGY-I-35 |
| 50 | 11 | 22 | 30 | 47 | 10 | 15 | 15 | 30 | 40 | SGY-I-29 | SGY-I-35 | SGY-I-41 |
| 61 | 18.5 | 30 | 37 | 59 | 15 | 15 | 20 | 40 | 50 | SGY-I-35 | SGY-I-41 | SGY-I-55 |
| 71 | 18.5 | 37 | 45 | 71 | 20 | 20 | 25 | 50 | 60 | SGY-I-41 | SGY-I-55 | SGY-I-66 |
| 95 | 22 | 45 | 55 | 90 | 25 | 30 | 30 | 60 | 75 | SGY-I-55 | SGY-I-66 | SGY-I-80 |
| 114 | 30 | 55 | 75 | 113 | 30 | 30 | 40 | 75 | 100 | SGY-I-66 | SGY-I-80 | SGY-I-100 |
| 139 | 37 | 75 | 90 | 133 | 40 | 40 | 50 | 100 | 125 | SGY-I-80 | SGY-I-100 | SGY-I-132 |
| 173 | 55 | 90 | 110 | 171 | 50 | 60 | 60 | 125 | 150 | SGY-I-100 | SGY-I-132 | SGY-I-160 |
| 229 | 55 | 110 | 160 | 217 | 60 | 75 | 75 | 150 | 200 | SGY-I-132 | SGY-I-160 | SGY-I-195 |
| 277 | 75 | 150 | 185 | 270 | 75 | 75 | 100 | 200 | 250 | SGY-I-160 | SGY-I-195 | See Size 3 |
| 338 | 90 | 185 | 220 | 333 | 100 | 100 | 125 | 250 | 300 | SGY-I-195 | See Size 3 | See Size 3 |

Size 3 and 4

| I _e ¹⁾ | kW | | | FLA ¹⁾ | Hp | | | | | Trip Class 10 I _e : AC-53a: 3.5-17: 90-3 VMX- | Trip Class 20 I _e : AC-53a: 4-19: 90-3 VMX- | Trip Class 30 I _e : AC-53a: 4-29: 90-3 VMX- |
|------------------------------|-----|------|------|-------------------|------|-----|------|------|--------------|--|--|--|
| | A | 230V | 400V | | 500V | A | 200V | 208V | 220- 240V | | | |
| 277 | 75 | 150 | 185 | 270 | 75 | 75 | 100 | 200 | 250 | See Size 2 | See Size 2 | SGY-I-242 |
| 338 | 90 | 185 | 220 | 312 | 100 | 100 | 125 | 250 | 300 | See Size 2 | SGY-I-242 | SGY-I-302 |
| 419 | 132 | 220 | 300 | 419 | 150 | 150 | 150 | 350 | 450 | SGY-I-242 | SGY-I-302 | SGY-I-361 |
| 523 | 160 | 300 | 375 | 523 | 150 | 150 | 200 | 450 | 500 | SGY-I-302 | SGY-I-361 | SGY-I-430 |
| 625 | 200 | 355 | 425 | 625 | 200 | 200 | 250 | 500 | 600 | SGY-I-361 | SGY-I-430 | SGY-I-500 |
| 745 | 220 | 425 | 530 | 717 | 250 | 250 | 250 | 500 | 700 | SGY-I-430 | SGY-I-500 | SGY-I-625 |
| 866 | 280 | 500 | 630 | 831 | 250 | 300 | 300 | 600 | 800 | SGY-I-500 | SGY-I-625 | SGY-I-722 |
| 1083 | 335 | 600 | 800 | 1083 | 350 | 350 | 400 | 800 | 1000 | SGY-I-625 | SGY-I-722 | SGY-I-850 |
| 1251 | 400 | 710 | 900 | 1251 | 450 | 450 | 500 | 1000 | 1250 | SGY-I-722 | SGY-I-850 | - |
| 1472 | 475 | 850 | 1000 | 1472 | 500 | 500 | 600 | 1100 | 1500 | SGY-I-850 | - | - |

¹⁾ Maximum motor line current indicated. For In-Delta connections, all six motor wires must be available for connection, and it is critical to exactly follow the In-Delta wiring diagram in the Synergy Quick Start Guide. The Soft Starter will only sense the Phase Current, which is about 57.7% of the motor line current.

Installation

4.4 Short Circuit Protection

Size 1

| Type designation (eg. VMX-SGY-I-...) | | | 17 | 22 | 29 | 35 | 41 | 55 | 66 | 80 | 100 |
|---|----------------------|----|--|-----|-----|-----|--|-----|-----|-----|-----|
| Rated operational currents | I_e | A | 17 | 22 | 29 | 35 | 41 | 55 | 66 | 80 | 100 |
| Rated conditional short circuit current | I_q | kA | 10 | 10 | 10 | 10 | 10 | 10 | 10 | 10 | 10 |
| Class J time-delay fuse #1 | Maximum rating Z_1 | A | 25 | 30 | 40 | 45 | 60 | 70 | 90 | 100 | 125 |
| UL Listed inverse-time delay circuit breaker #1 | Maximum rating Z_2 | A | 25 | 30 | 40 | 45 | 60 | 70 | 90 | 100 | 125 |
| Semiconductor fuse (class aR) #2 | Type | | Mersen 6,9 URD 30 _ Bussmann 170M30__ Bussmann 170M31__ Bussmann 170M32__ SIBA 20 61__ | | | | Mersen 6,9 URD 31__ Bussmann 170M40__ Bussmann 170M41__ Bussmann 170M42__ SIBA 20 61__ | | | | |
| | Fuse rating | A | 100 | 100 | 160 | 160 | 200 | 200 | 200 | 315 | 315 |

Size 2 and 3

| Type designation (eg. VMX-SGY-I-...) | | | 132 | 160 | 195 | 242 | 302 | 361 | 430 | 500 |
|---|----------------------|----|--|-----|-----|--|-----|-------------------------------------|------|------|
| Rated operational currents | I_e | A | 132 | 160 | 195 | 242 | 302 | 361 | 430 | 500 |
| Rated conditional short circuit current | I_q | kA | 10 | 10 | 10 | 18 | 18 | 18 | 30 | 30 |
| Class J time-delay fuse #1 | Maximum rating Z_1 | A | 175 | 200 | 250 | 350 | 400 | 450 | 600 | 600 |
| UL Listed inverse-time delay circuit breaker #1 | Maximum rating Z_2 | A | 175 | 200 | 250 | 400 | 500 | 600 | 700 | 800 |
| Semiconductor fuse (class aR) #2 | Type | | Mersen 6,9 URD 31__ Bussmann 170M40__ Bussmann 170M41__ Bussmann 170M42__ SIBA 20 61__ | | | Mersen 6,9 URD 33__ Bussmann 170M60__ Bussmann 170M61__ Bussmann 170M62__ SIBA 20 63__ | | Mersen 6,9 URD 33__ SIBA 20 63__ | | |
| | Fuse rating | A | 400 | 550 | 550 | 900 | 900 | 900 | 1000 | 1000 |

Size 4

| Type designation (eg. VMX-SGY-I-...) | | | 625 | 722 | 850 |
|---|----------------------|----|---|------|------|
| Rated operational currents | I_e | A | 625 | 722 | 850 |
| Rated conditional short circuit current | I_q | kA | 42 | 42 | 42 |
| Class L time delay fuse #1 | Maximum rating Z_1 | A | 800 | 1000 | 1200 |
| UL Listed inverse-time delay circuit breaker #1 | Maximum rating Z_2 | A | 1000 | 1200 | 1200 |
| Semiconductor fuse (class aR) #2 | Type | | Mersen PC36UD69V**CP11 SIBA 20 688 32 | | |

Note: For Mersen fuses ** is 18 for 1800A fuse and 20 for 2000A fuse.

1. Suitable For Use On A Circuit Capable Of Delivering Not More Than I_q rms Symmetrical Amperes, 600 Volts Maximum, When Protected by Class J or Class L time delay Fuses as indicated with a Maximum Rating of Z_1 or by a Circuit Breaker with a Maximum Rating of Z_2 .

2. Correctly selected semiconductor fuses can provide additional protection against damage to the synergy unit. These semiconductor fuses are recommended to provide this increased protection.

Installation

4.5 Electronic Overload Relay

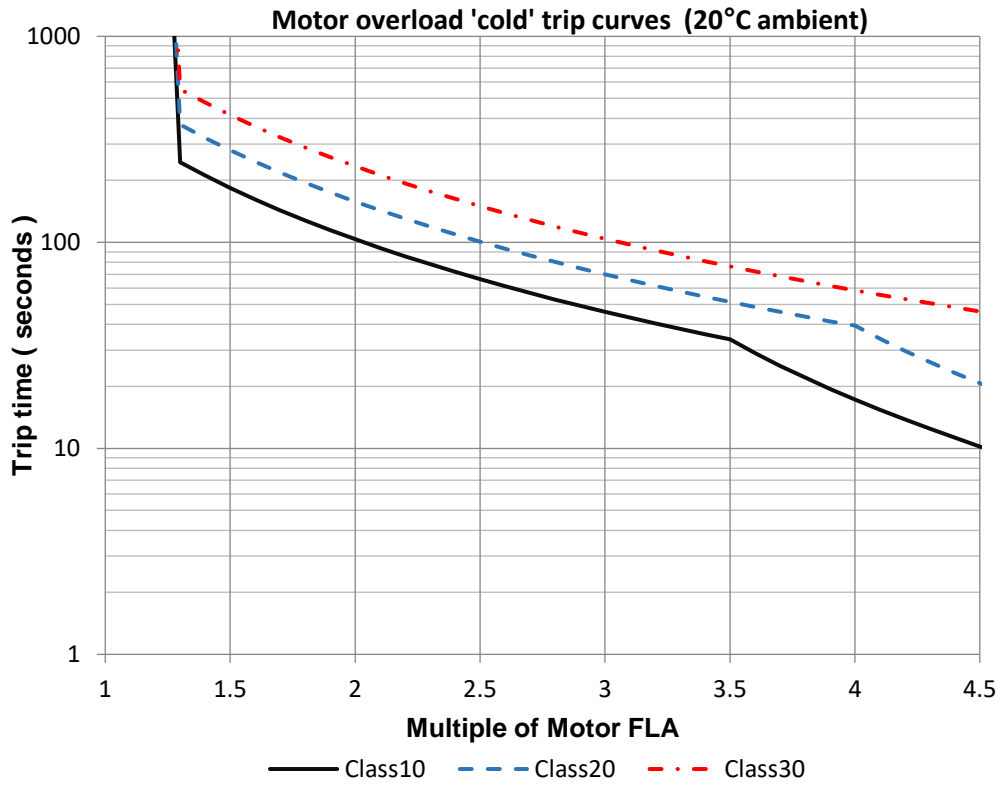

Fig.1 : Trip curves

Note: When the overload has tripped, there is a forced cooling time to allow the overload to recover before the next start. The 'warm' trip times are 50% of the 'cold' trip time.

Installation

4.6 Conductor Size and Torque Requirements

| Terminal | | Models | Conductor Size | | Torque | |
|---|--------------|-----------------------------------|-------------------------|------------------|--------|-------|
| | | | Metric | Imperial | Nm | lb-in |
| Main Terminals Cu STR 75°C only | Terminal | VMX-SGY-I-17 to VMX-SGY-I-100 | 2.5 - 70mm ² | 12- 2/0AWG | 9 | 80 |
| | | VMX-SGY-I-132 to VMX-SGY-I-195 | 4 - 185mm ² | 12 – 350MCM | 14 | 124 |
| | M10 bolt | VMX-SGY-I-242 to VMX-SGY-I-361 | 2 x 95mm ² | 2 x 4/0AWG | 28 | 248 |
| | | VMX-SGY-I-430 to VMX-SGY-I-500 | 2 x 150mm ² | 2 x 350MCM | | |
| | 2 x M10 bolt | VMX-SGY-I-625 to VMX-SGY-I-850 | 3 x 240 mm ² | 3 x 400MCM | | |
| Main Terminals Copper busbar ²⁾ | 2 x M10 bolt | VMX-SGY-I-625 to VMX-SGY-I-850 | 60mm x 10mm | 2.0in x 0.5in | | |
| Control terminals | | All models | 0.2–1.5mm ² | 24- 16AWG | 0.7 | 6.0 |
| Protective Earth ¹⁾ Cu only | M6 stud | VMX-SGY-I-17 to VMX-SGY-I-41 | ≥ 6mm ² | ≥ 10AWG | 8 | 71 |
| | | VMX-SGY-I-55 to VMX-SGY-I-80 | ≥ 10mm ² | ≥ 8AWG | | |
| | | VMX-SGY-I-100 | ≥ 16mm ² | ≥ 6AWG | | |
| | M8 stud | VMX-SGY-I-132 to VMX-SGY-I-160 | ≥ 16mm ² | ≥ 6AWG | 12 | 106 |
| | | VMX-SGY-I-195 | ≥ 25mm ² | ≥ 4AWG | | |
| | | VMX-SGY-I-242 | ≥ 35mm ² | ≥ 3AWG | | |
| | | VMX-SGY-I-302 | ≥ 35mm ² | ≥ 2AWG | | |
| | | VMX-SGY-I-361 | ≥ 50mm ² | ≥ 1AWG | | |
| | | VMX-SGY-I-430 to VMX-SGY-I-500 | ≥ 70mm ² | ≥ 1/0AWG | | |
| | | VMX-SGY-I-625 to VMX-SGY-I-850 | ≥ 85mm ² | ≥ 3/0AWG | | |

¹⁾ Protective Earth wire size based on bonding conductor requirements of UL508 Table 7.4 and UL508A Table 15.1, with suitable equivalent metric conductor sizes as per IEC 60947-1 Table 7a.

²⁾ Maximum busbar sizes based on IEC 60947-1 Table 11.

³⁾ The actual conductor used must comply with local wiring regulations.

5. Operation

5.1 Configuration and Parameters

5.1.1 Features

Status LED

The LED on the VMX-Synergy Plus™ front panel will blink once every 10 seconds to provide visual confirmation that all microprocessors in the soft starter are operating properly.

Configuration Overview

Configuring VMX-Synergy Plus™ soft starters is as simple as setting the parameters to match your motor, application, power source, control scheme, etc.

VMX- Synergy Plus™ may be configured from its touchscreen, from an optional remote touchscreen, or from a PLC using Modbus RTU via the onboard RJ45 connector.

Auto Setup Procedure

Allows the user to change all the parameters at once to settings that are typical for general applications. One or more parameters as can be adjusted to fine tune the settings for your specific application.

Setup by Individual Parameter Settings

Allows the user to change the parameter settings one at a time. The individual parameters are grouped by categories as on the touchscreen.

Configuration from Touchscreen

Use the on-screen buttons to enter data or to scroll through setup menus, using the “UP,” DOWN,” “BACK,” and “NEXT” buttons as necessary. From the home “Menu” screen, select either “Auto Setup” or “Advanced.”

Auto Setup

On initial power up, VMX-Synergy Plus™ will show a ‘Setup Wizard’ menu – Auto and Advanced. To jump immediately to the pre-defined parameter sets, press the Auto button and follow the on-screen prompts. Refer to the example on the following screen.

Refer to the example on the following screen.

To automatically set up parameters on subsequent start-up, select the ‘Home’ menu from the status screen and select ‘Auto Setup’. Follow the on-screen prompts. Refer to the example on the following screen.

Individual Parameter Setup

From the Setup Wizard or ‘Home’ menu, select the ‘Advanced’ menu. Set the required parameters from the displayed menus. See Section 3 for detailed descriptions of the available parameters.

Operation

5.2 On Screen Menus

Initial Screen



Displayed on **FIRST** switch-on **ONLY**.

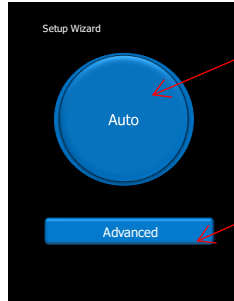

Auto Setup wizard.

Advanced menu

Status Screen

Supply Status
Turns **RED** if unit has tripped on supply failure

Motor Overload Status
Turns **RED** if unit has tripped on overload

Status Messages

Motor Side Status
Turns **RED** if unit has tripped on motor side phase loss

Returns to previous screen/menu

Enters Sub-Menus

Temperature Status
Turns **RED** if unit has tripped on over temperature

Cooling Fan Status
Turns **RED** if unit has tripped on fan failure

Internal Bypass Status (open/closed)

Displays Overload Percentage, Instantaneous running Current and Power

Start/Stop Motor
Only active if Local Control Enabled

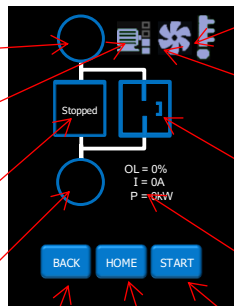

Home Screen

Auto-Setup Menu

Input/Output Menu

Logging Menu

Advanced Menus

Monitor Screens

Device Menu



See 'Status Screen'

Operation

5.3 Auto Setup Example

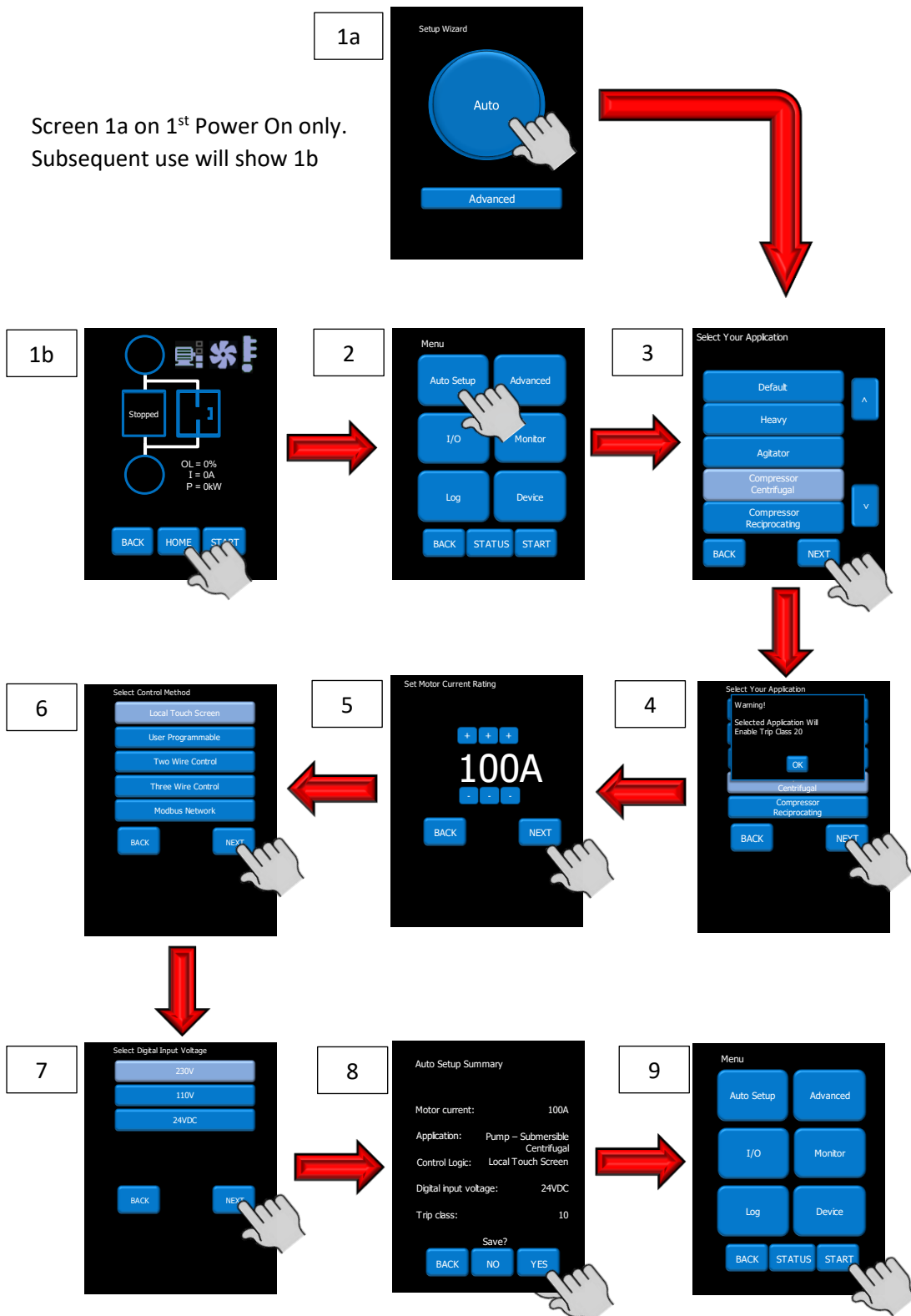

Operation

5.4 Auto-Setup Parameter Settings

| # | Application | Start pedestal | Stop pedestal | Start time | Soft stop time | Trip Class | Current limit level | Current limit time | Optimize rate | Auto pedestal | Auto End Start 2 | Auto End Start 1 | Auto End 3 | Delta Operation | Auto stop | Soft stop smoothing | spare | Auto ramp | Auto end stop | Auto Impact load | Current limit - stopping | Current limit time |
|----|--|----------------|---------------|------------|----------------|------------|---------------------|--------------------|---------------|---------------|------------------|------------------|------------|-----------------|-----------|---------------------|-------|-----------|---------------|------------------|--------------------------|--------------------|
| - | Unit | % | % | s | s | - | FLC | s | - | En | En | En | En | En | En | En | En | En | En | En | FLC | s |
| 0 | Default | 20 | 10 | 10 | 0 | 10 | 3.5 | 30 | 5 | 0 | 0 | 0 | 1 | 1 | 0 | 0 | 0 | 0 | 0 | 0 | 8 | 2 |
| 1 | Heavy | 40 | 10 | 10 | 0 | 20 | 4 | 40 | 5 | 1 | 0 | 1 | 1 | 1 | 0 | 0 | 0 | 0 | 0 | 0 | 8 | 2 |
| 2 | Agitator | 30 | 10 | 10 | 0 | 10 | 3.5 | 25 | 5 | 1 | 0 | 1 | 1 | 1 | 0 | 0 | 0 | 0 | 0 | 0 | 8 | 2 |
| 3 | Compressor - Centrifugal | 35 | 10 | 15 | 0 | 20 | 3.5 | 25 | 5 | 1 | 0 | 1 | 1 | 1 | 0 | 0 | 0 | 0 | 0 | 0 | 8 | 2 |
| 4 | Compressor - Reciprocating | 45 | 10 | 15 | 0 | 20 | 3.5 | 25 | 15 | 1 | 0 | 1 | 1 | 1 | 0 | 0 | 0 | 0 | 0 | 0 | 8 | 2 |
| 5 | Compressor - Screw | 40 | 10 | 15 | 0 | 20 | 3.5 | 25 | 5 | 1 | 0 | 1 | 1 | 1 | 0 | 0 | 0 | 0 | 0 | 0 | 8 | 2 |
| 6 | Compressor - Vane | 35 | 10 | 7 | 0 | 10 | 3.5 | 25 | 5 | 1 | 0 | 1 | 0 | 1 | 0 | 0 | 0 | 0 | 0 | 0 | 8 | 2 |
| 7 | Compressor - Scroll | 35 | 10 | 7 | 0 | 10 | 3.5 | 25 | 15 | 1 | 0 | 1 | 0 | 1 | 0 | 0 | 0 | 0 | 0 | 0 | 8 | 2 |
| 8 | Ball Mill | 40 | 10 | 10 | 0 | 20 | 5.5 | 25 | 5 | 1 | 0 | 1 | 0 | 1 | 0 | 0 | 0 | 0 | 0 | 0 | 8 | 2 |
| 9 | Centrifuge | 40 | 10 | 10 | 0 | 30 | 2.5 | 300 | 5 | 1 | 0 | 1 | 0 | 1 | 0 | 0 | 0 | 0 | 0 | 0 | 8 | 2 |
| 10 | Bow Thruster - Zero Pitch | 10 | 10 | 10 | 0 | 10 | 2.5 | 25 | 5 | 1 | 1 | 0 | 1 | 1 | 0 | 0 | 0 | 0 | 0 | 0 | 8 | 2 |
| 11 | Bow Thruster - Loaded | 10 | 10 | 10 | 0 | 20 | 4 | 25 | 5 | 1 | 1 | 0 | 1 | 1 | 0 | 0 | 1 | 0 | 0 | 0 | 8 | 2 |
| 12 | Conveyor - Unloaded | 10 | 10 | 10 | 7 | 10 | 3.5 | 30 | 5 | 1 | 0 | 1 | 0 | 1 | 1 | 1 | 1 | 0 | 1 | 0 | 2 | 10 |
| 13 | Conveyor - Loaded | 10 | 10 | 10 | 7 | 20 | 5.5 | 30 | 5 | 1 | 0 | 1 | 0 | 1 | 1 | 1 | 0 | 0 | 1 | 0 | 2 | 10 |
| 14 | Crusher | 40 | 10 | 10 | 0 | 30 | 3.5 | 60 | 5 | 1 | 0 | 1 | 0 | 1 | 0 | 0 | 0 | 0 | 0 | 0 | 8 | 2 |
| 15 | Fan - Low Inertia | 30 | 10 | 15 | 0 | 10 | 3.5 | 30 | 5 | 1 | 0 | 1 | 0 | 1 | 0 | 1 | 0 | 0 | 0 | 0 | 8 | 2 |
| 16 | Fan - High Inertia | 40 | 10 | 10 | 0 | 30 | 3.5 | 60 | 5 | 1 | 0 | 1 | 0 | 1 | 0 | 0 | 0 | 0 | 0 | 0 | 8 | 2 |
| 17 | Feeder - screw | 20 | 10 | 10 | 0 | 10 | 3.5 | 25 | 5 | 1 | 0 | 1 | 0 | 1 | 0 | 0 | 0 | 0 | 0 | 0 | 8 | 2 |
| 18 | Grinder | 40 | 10 | 10 | 0 | 20 | 3.5 | 40 | 5 | 1 | 0 | 1 | 0 | 1 | 0 | 0 | 0 | 0 | 0 | 0 | 8 | 2 |
| 19 | Hammer Mill | 40 | 10 | 10 | 0 | 20 | 3.5 | 40 | 5 | 1 | 0 | 1 | 0 | 1 | 0 | 0 | 0 | 0 | 0 | 0 | 8 | 2 |
| 20 | Lathe Machines | 10 | 10 | 15 | 0 | 10 | 3.5 | 25 | 5 | 1 | 0 | 1 | 0 | 1 | 0 | 0 | 0 | 0 | 0 | 0 | 8 | 2 |
| 21 | Mills - flour etc | 40 | 10 | 10 | 0 | 20 | 3.5 | 40 | 5 | 1 | 0 | 1 | 0 | 1 | 0 | 0 | 0 | 0 | 0 | 0 | 8 | 2 |
| 22 | Mixer - Unloaded | 10 | 10 | 10 | 0 | 10 | 3.5 | 25 | 5 | 1 | 0 | 1 | 0 | 1 | 0 | 0 | 0 | 0 | 0 | 0 | 8 | 2 |
| 23 | Mixer - Loaded | 10 | 10 | 10 | 0 | 20 | 4 | 25 | 5 | 1 | 0 | 1 | 0 | 1 | 0 | 0 | 0 | 0 | 0 | 0 | 8 | 2 |
| 24 | Moulding Machine | 10 | 10 | 10 | 0 | 10 | 4.5 | 25 | 5 | 1 | 0 | 1 | 0 | 1 | 0 | 0 | 0 | 0 | 0 | 1 | 8 | 2 |
| 25 | Pelletisers | 40 | 10 | 10 | 0 | 20 | 5.5 | 25 | 5 | 1 | 0 | 1 | 0 | 1 | 0 | 0 | 0 | 0 | 0 | 0 | 8 | 2 |
| 26 | Plastic and Textile Machines | 10 | 10 | 10 | 0 | 10 | 4.5 | 25 | 5 | 1 | 0 | 1 | 0 | 1 | 0 | 0 | 1 | 0 | 0 | 1 | 8 | 2 |
| 27 | Press, Flywheel | 40 | 10 | 10 | 0 | 20 | 3.5 | 40 | 5 | 1 | 0 | 1 | 0 | 1 | 0 | 0 | 1 | 0 | 0 | 1 | 8 | 2 |
| 28 | Pump - Submersible Centrifugal | 10 | 10 | 10 | 60 | 10 | 3.5 | 25 | 5 | 1 | 0 | 0 | 0 | 1 | 1 | 1 | 1 | 0 | 1 | 0 | 2 | 25 |
| 29 | Pump - Submersible Rotodynamic | 10 | 10 | 10 | 60 | 10 | 3.5 | 25 | 5 | 1 | 0 | 0 | 0 | 1 | 1 | 1 | 1 | 0 | 1 | 0 | 2 | 25 |
| 30 | Pump - Positive Displacement Reciprocating | 10 | 10 | 10 | 60 | 20 | 3.5 | 25 | 15 | 1 | 0 | 0 | 0 | 1 | 1 | 1 | 0 | 0 | 1 | 0 | 2 | 25 |
| 31 | Pump - Positive displacement Rotary | 10 | 10 | 10 | 60 | 20 | 3.5 | 25 | 15 | 1 | 0 | 0 | 0 | 1 | 1 | 1 | 0 | 0 | 1 | 0 | 2 | 25 |

(continued overleaf)

Operation

Auto-Setup Parameter Setting (continued)

| # | Application | Start pedestal | Stop pedestal | Start time | Soft stop time | Trip Class | Current limit level | Current limit time | Optimize rate | Auto pedestal | Auto End Start 2 | Auto End Start 1 | Auto End 3 | Delta Operation | Auto stop | Soft stop smoothing | spare | Auto ramp | Auto end stop | Impact load | Current limit - stopping | Current limit time | |
|----|----------------------------------|----------------|---------------|------------|----------------|------------|---------------------|--------------------|---------------|---------------|------------------|------------------|------------|-----------------|-----------|---------------------|-------|-----------|---------------|-------------|--------------------------|--------------------|---|
| | | % | % | s | s | - | FLC | s | - | En | En | En | En | En | En | En | En | En | En | En | En | FLC | s |
| 32 | Pump Jack | 40 | 10 | 10 | 0 | 2 | 3.5 | 40 | 5 | 1 | 0 | 1 | 0 | 1 | 0 | 0 | 0 | 0 | 0 | 0 | 1 | 8 | 2 |
| 33 | Rolling Mill | 40 | 10 | 10 | 0 | 2 | 3.5 | 40 | 5 | 1 | 0 | 1 | 0 | 1 | 0 | 0 | 0 | 0 | 0 | 0 | 0 | 8 | 2 |
| 34 | Roots Blower | 30 | 10 | 10 | 0 | 2 | 4.5 | 25 | 5 | 1 | 0 | 1 | 0 | 1 | 0 | 0 | 0 | 0 | 0 | 0 | 0 | 8 | 2 |
| 35 | Saw - Band | 10 | 10 | 10 | 0 | 1 | 3.5 | 25 | 5 | 1 | 0 | 1 | 0 | 1 | 0 | 0 | 0 | 0 | 0 | 0 | 0 | 8 | 2 |
| 36 | Saw - Circular | 40 | 10 | 10 | 0 | 2 | 3.5 | 40 | 5 | 1 | 0 | 1 | 0 | 1 | 0 | 0 | 0 | 0 | 0 | 0 | 0 | 8 | 2 |
| 37 | Screen - Vibrating | 40 | 10 | 10 | 0 | 2 | 4.5 | 40 | 5 | 1 | 0 | 1 | 0 | 1 | 0 | 0 | 0 | 0 | 0 | 0 | 0 | 8 | 2 |
| 38 | Shredder | 40 | 10 | 10 | 0 | 3 | 3.5 | 60 | 5 | 1 | 0 | 1 | 0 | 1 | 0 | 0 | 0 | 0 | 0 | 0 | 0 | 8 | 2 |
| 39 | Transformers, Voltage Regulators | 10 | 10 | 5 | 0 | 1 | 3.5 | 25 | 5 | 0 | 0 | 0 | 0 | 1 | 0 | 0 | 0 | 0 | 0 | 0 | 0 | 8 | 2 |
| 40 | Tumblers | 20 | 10 | 10 | 0 | 2 | 4 | 25 | 5 | 1 | 0 | 1 | 0 | 0 | 0 | 0 | 0 | 0 | 0 | 0 | 0 | 8 | 2 |
| 41 | Wood Chipper | 40 | 10 | 10 | 0 | 3 | 3.5 | 60 | 5 | 1 | 0 | 1 | 0 | 0 | 0 | 0 | 0 | 0 | 0 | 0 | 0 | 8 | 2 |

Operation

5.5 Auto Reset Function

The Auto Reset feature automatically resets a selected number of faults and then attempts a start without user intervention. The time between the resets and the number of reset attempts are both programmable. If the Auto Reset has been successful, the Starter must operate trip free for a set time before the counters are re-initialised. If the number of attempts exceeds the set value, the Auto Reset terminates, and the counters will be re-initialised when a Reset or Stop signal is given by the user.



WARNING:
When Auto Reset is enabled, a tripped motor may restart automatically after the Reset Delay time. This may result in equipment damage or personal injury if the function is used in an unsuitable application. Do not use this function without considering applicable local, national, and international standards, regulations, or industry guidelines.

The Auto-Reset function is accessible from the Advanced Menu (see Auto-Reset section of parameter summaries):

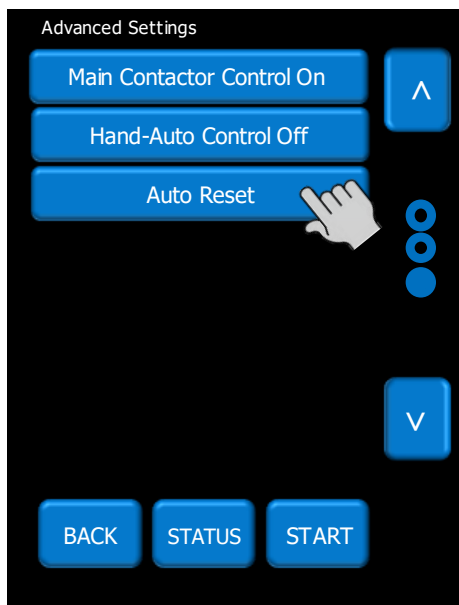

Operation

Auto Reset Function (continued)

The screenshot shows the 'Auto Reset' menu with the following options and callouts:

- Auto Reset Off**: Toggles the Auto-Reset function Off/On.
- Reset Delay 0s**: Delay between trip and Auto-Reset.
- Reset Attempts 0**: Number of permissible Auto-Reset attempts.
- Trip Free Time 600s**: The time the unit must be trip free before the counter is set to zero.
- Reset Trips**: Enters Auto-Rest trip selection menu (see below).

At the bottom of the menu are three buttons: BACK, STATUS, and START.

Example page of Reset Trips Sub Menu

The screenshot shows the 'Reset Trips' sub-menu with the following options:

- Input Side Phase Loss On
- Motor Side Phase Loss On
- Overload On
- Thyristor Firing On
- Sensing Fault On

Navigation is controlled by an up arrow (^) and a down arrow (v) on the right side of the menu. A callout indicates: "Scroll through Auto-Reset Trips".

At the bottom of the menu are three buttons: BACK, STATUS, and START.

Operation

Auto Reset Function (continued)



The status of the Auto-Reset function may be observed in the 'Monitor' menu

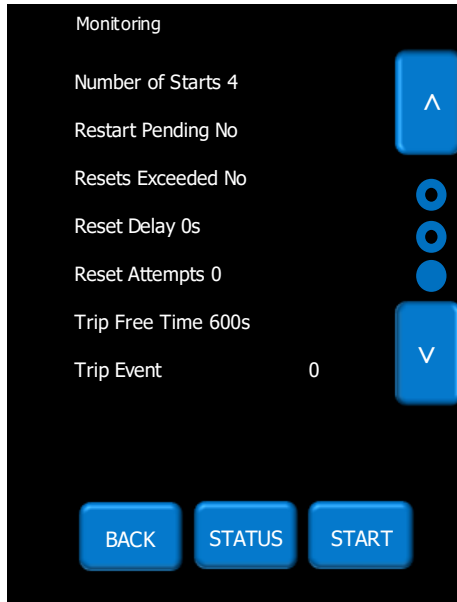

5.5.1 Mapping Auto Reset Status to Digital Outputs

Auto Reset Pending and Auto Reset Exceeded may be mapped to the Digital Outputs (D1 – D5). The selection screen is located in the I/O Menu:

I/O – DIGITAL OUTPUTS – DIGITAL OUTPUT (1 to 5) – SELECT FUNCTION

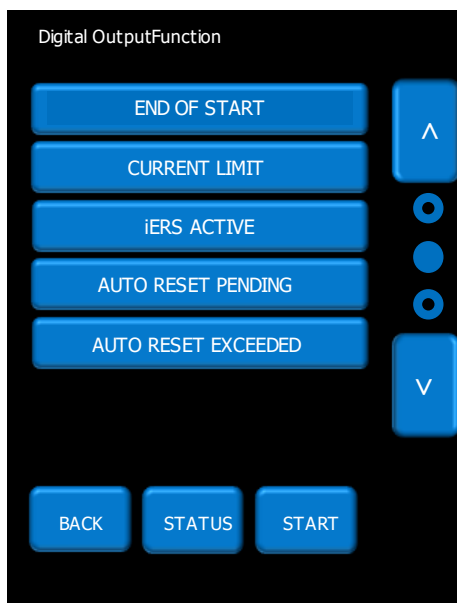

Operation

Auto Reset Function (continued)

5.5.2 Two-Wire, Three-Wire and Communications Control

The Auto Reset operates with Two-Wire, Three-Wire and communications start/stop. Generally, this is not a problem if the control supply is maintained, although warning should be given that in Three-Wire and communications control the motor may start without a direct start signal. (Although it is implied as no stop had been given during the reset delay period).

5.5.3 Control Supply Loss

When the control supply is removed the microcontroller is unable to make calculations in real time. To overcome this the calculations are made retrospectively when the starter powers up.

Two Wire: Following a control supply loss the Start signal must be retained (Fig 5.6.2).

Three Wire: The state of the start signal is saved when the control supply is removed and if it was set to 'start' the Auto Reset will continue at power up. When operating in this mode the motor may start at power up without a start signal being present (Fig 5.6.3).

5.5.4 Modbus/Communications

The state of the start signal is saved when the control supply is removed and if it was set to 'start' the Auto Reset will continue at power up. When operating in this mode the motor may start at power up without a start signal being present (Fig 5.6.3).

Auto Restart Termination: If the time to re-establish the power exceeds the Reset Delay x Reset Attempts the Auto Reset terminates.

5.5.5 Overload Trip

Following an overload trip, the overload will at 100% and then cool exponentially to 0% after several minutes.

If a restart is attempted too soon the starter will trip again as the overload would not have cooled to a sufficient level (Fig 5.6.5).

It must be ensured the Reset Delay is long enough to allow the overload to cool. This is also the case for the heatsink over temperature trip.

5.5.6 Remote Start on Trip

If Auto Reset is turned on the Remote Start On trip trips are disabled and will be ignored.

5.5.7 Hand/Auto

If the Hand Auto option is selected the Hand Selection will override the Auto Reset.

The Auto Reset will be terminated, and the counters will be re-initialised.

Operation

5.6 Auto Reset Timing Diagrams

Fig 5.6.1: Auto Reset - Two Wire -Three Phase Supply Loss

The timing diagrams show the auto reset with a maintained two wire control system
 The fault shown is a 3-phase supply loss only, the Control Supply maintained
 The 3-Phase power is re-established (after the 2nd attempt) before the Reset Attempts counter is depleted
 This assumes the start signal is maintained, if it is removed the Auto Reset terminates
 Once power has been re-established there are no further outages and the counters are reset after the trip free time.

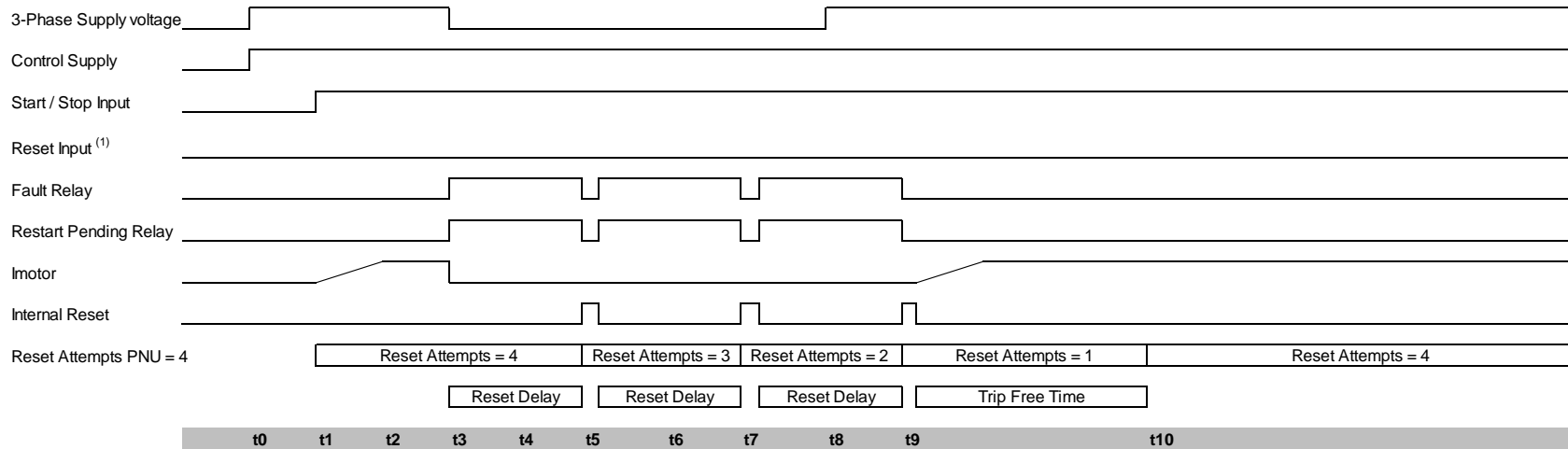

| Sequence of events | |
|--------------------|--|
| t0 | 3 phase supply applied |
| t1 | Start signal applied, motor starts |
| t2 | Motor reaches full voltage |
| t3 | 3 phase supply removed |
| t4 | Start signal must still be applied |
| t5 | If it has been removed Auto Reset feature re-initialises |
| t5 | Reset delay = 0 Restart Attempt = 3 |
| t6 | Reset Signal must be low |
| t6 | If the trip is reset the Auto Reset feature re-initialises |
| t7 | Reset delay = 0 Restart Attempt = 2 |
| t8 | 3-Phase re-established |
| t9 | Reset delay = 0 Restart Attempt = 1 |
| t10 | Trip Free Delay = 0 Restart Attempt = 4 |

| User Parameters (R/W) | | |
|-----------------------|----------------------|---------|
| PNU | Range | Default |
| Auto Reset | Off / On | Off |
| Reset Delay | 0-7200s | 0s |
| Reset Attempts | 0-10 | 0 |
| Reset Trips | All resettable trips | - |
| Trip Free Time | 0-7200s | 600s |

| Monitor Parameters (R/O) | |
|-------------------------------------|---------|
| PNU | Range |
| Auto Reset Pending | 0-1 |
| Auto Reset Exceeded | 0-1 |
| Auto Reset Delay Remaining | 0-7200s |
| Auto Reset Attempts Remaining | 0-10 |
| Auto Reset Trip Free Time Remaining | 0-7200s |

Notes
 For Two Wire control reset occurs automatically when the start signal changes state from low to high, reset shown is programmable reset input ⁽¹⁾

Operation

Auto Reset Timing Diagrams (continued)

Fig 5.6.2 Auto Reset - Two Wire - Control Supply Loss

The timing diagrams show the auto reset with a maintained two wire control system
 The fault shown is a 3-phase supply loss **and** Control supply loss
 The 3-Phase power and control supply are re-established (after the 2nd attempt) before the Reset Attempts counter is depleted
 This assumes the start signal is maintained, if it is removed the Auto Reset terminates
 Once power has been re-established there are no further outages and the counters are reset after the trip free time.

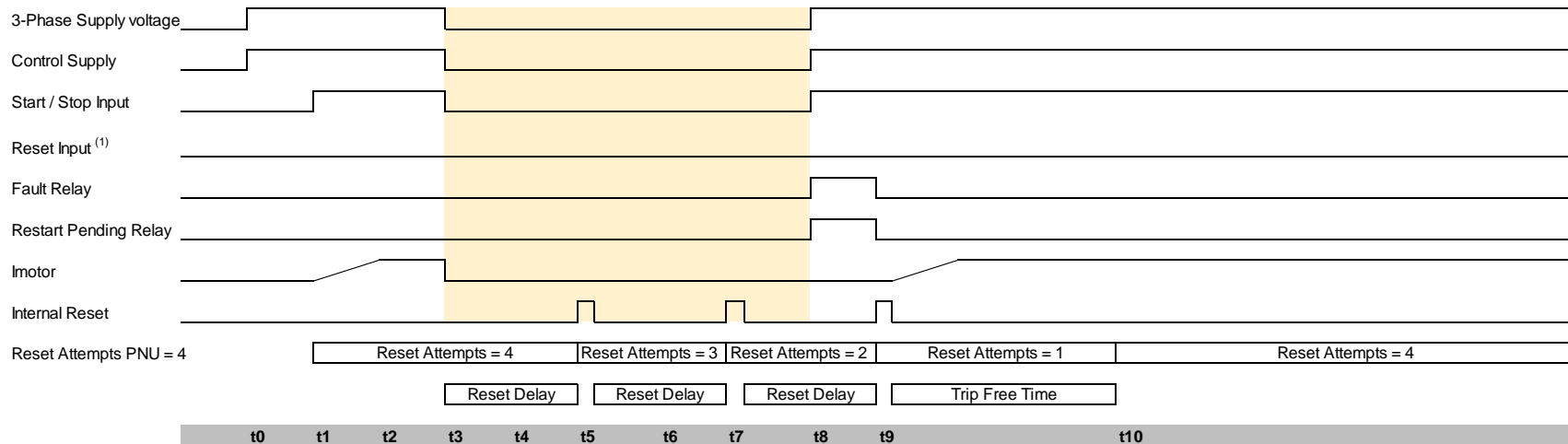

| Sequence of events | |
|--------------------|--|
| t0 | 3 phase supply applied |
| t1 | Start signal applied, motor starts |
| t2 | Motor reaches full voltage |
| t3 | 3 phase supply removed |
| t5 | Reset delay = 0 Restart Attempt = 3 |
| t7 | Reset delay = 0 Restart Attempt = 2 |
| t8 | 3-Phase re-established Start signal must still be applied If it has been removed Auto Reset feature re-initialises If the trip is reset the Auto Reset feature re-initialises |
| t9 | Reset delay = 0 Restart Attempt = 1 |
| t10 | Trip Free Delay = 0 Restart Attempt = 4 |

| User Parameters (R/W) | | |
|-----------------------|----------------------|---------|
| PNU | Range | Default |
| Auto Reset | Off / On | Off |
| Reset Delay | 0-7200s | 0s |
| Reset Attempts | 0-10 | 0 |
| Reset Trips | All resettable trips | - |
| Trip Free Time | 0-7200s | 600s |

| Monitor Parameters (R/O) | |
|-------------------------------------|---------|
| PNU | Range |
| Auto Reset Pending | 0-1 |
| Auto Reset Exceeded | 0-1 |
| Auto Reset Delay Remaining | 0-7200s |
| Auto Reset Attempts Remaining | 0-10 |
| Auto Reset Trip Free Time Remaining | 0-7200s |

Notes
 The Starter is powered down between t3 and t8 (yellow shaded region)
 During this time controller is unable to make the calculations in real time
 To overcome this the calculations are made retrospectively at time t8
 The Start Signal must be maintained, if it is not the Auto Restart will be terminated
 For Two Wire control reset occurs automatically when the start signal changes state from low to high, reset shown is programmable reset input ⁽¹⁾
 If the time to re-establish the power exceeds (Reset Delay x Reset Attempts) to Auto Reset terminates

Operation

Auto Reset Timing Diagrams (continued)

Fig 5.6.3 Auto Reset - Three Wire - Three Phase Supply Loss

The timing diagrams show the auto reset with Three wire / Modbus control
 The fault shown is a 3-phase supply loss only, the Control Supply maintained
 The 3-Phase power is re-established (after the 2nd attempt) before the Reset Attempts counter is depleted
 This assumes the momentary stop signal is not activated, if it is the Auto Reset terminates
 Once power has been re-established there are no further outages and the counters are reset after the trip free time.

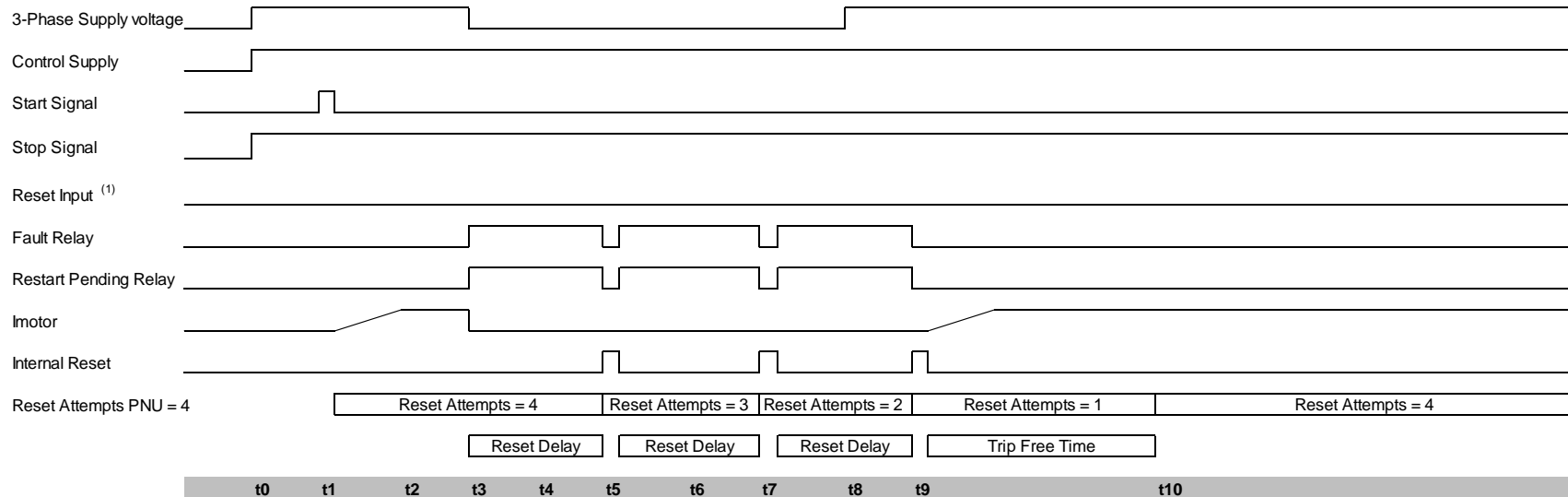

| Sequence of events | |
|--------------------|--|
| t0 | 3 phase supply applied |
| t1 | Start signal applied, motor starts |
| t2 | Motor reaches full voltage |
| t3 | 3 phase supply removed |
| t4 | Start signal must still be applied If it has been removed Auto Reset feature re-initialises |
| t5 | Reset delay = 0 Restart Attempt =3 |
| t6 | Rest Signal must be low If the trip is reset the Auto Reset feature re-initialises |
| t7 | Reset delay = 0 Restart Attempt =2 |
| t8 | 3-Phase re-established |
| t9 | Reset delay = 0 Restart Attempts =1 |
| t10 | Trip Free Delay = 0 Restart Attempts =4 |

| User Parameters (R/W) | | |
|-----------------------|----------------------|---------|
| PNU | Range | Default |
| Auto Reset | Off / On | Off |
| Reset Delay | 0-7200s | 0s |
| Reset Attempts | 0-10 | 0 |
| Reset Trips | All resettable trips | - |
| Trip Free Time | 0-7200s | 600s |

| Monitor Parameters (R/O) | |
|-------------------------------------|---------|
| PNU | Range |
| Auto Reset Pending | 0-1 |
| Auto Reset Exceeded | 0-1 |
| Auto Reset Delay Remaining | 0-7200s |
| Auto Reset Attempts Remaining | 0-10 |
| Auto Reset Trip Free Time Remaining | 0-7200s |

Notes
 (1) Seperate reset signal not avialbe on all products

Operation

Auto Reset Timing Diagrams (continued)

Fig 5.6.4 Auto Reset - Three Wire - Control Supply Loss

The timing diagrams show the auto reset with Three wire / Modbus control
 The fault shown is a 3-phase supply loss **and** Control supply loss
 The 3-Phase power and control supply are re-established (after the 2nd attempt) before the Reset Attempts counter is depleted
 This assumes the momentary stop signal is not activated, if it is the Auto Reset terminates
 Once power has been re-established there are no further outages and the counters are reset after the trip free time.

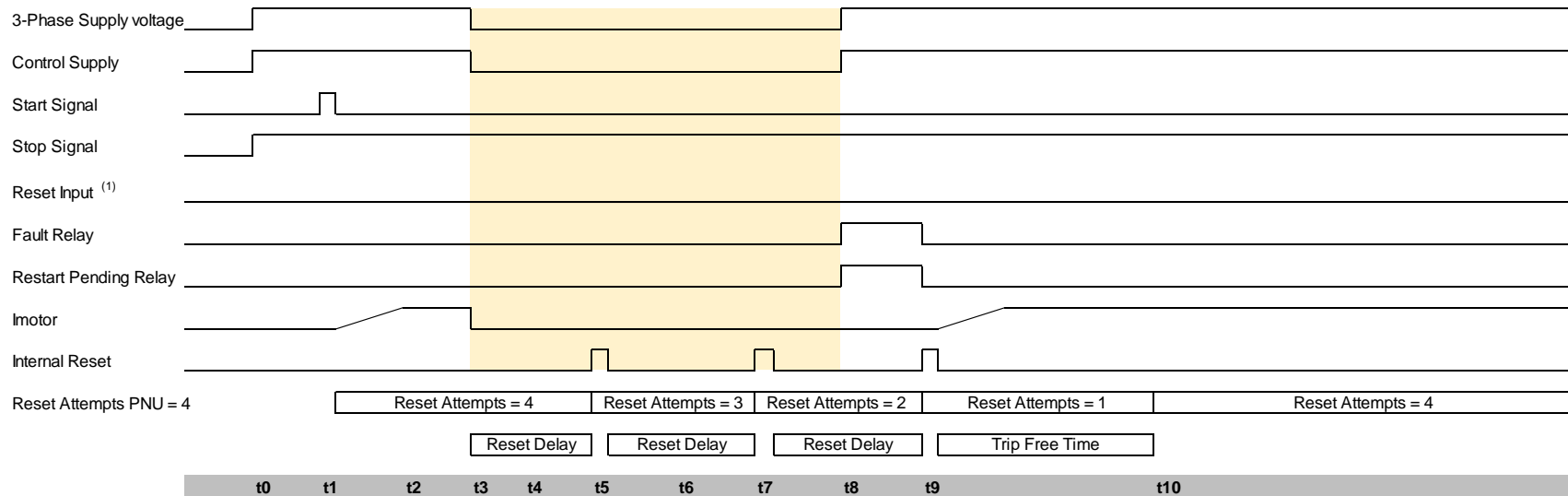

| Sequence of events | |
|--------------------|---|
| t0 | 3 phase supply applied |
| t1 | Start signal applied, motor starts |
| t2 | Motor reaches full voltage |
| t3 | 3 phase supply removed |
| t5 | Reset delay = 0 Restart Attempts = 3 |
| t7 | Reset delay = 0 Restart Attempts = 2 |
| t8 | 3-Phase re-established Start signal must still be applied If it has been removed Auto Reset feature re-initialises Rest Signal must be low If the trip is reset the Auto Reset feature re-initialises |
| t9 | Reset delay = 0 Restart Attempts = 1 |
| t10 | Trip Free Delay = 0 Restart Attempts = 4 |

| User Parameters (R/W) | | |
|-----------------------|----------------------|---------|
| PNU | Range | Default |
| Auto Reset | Off / On | Off |
| Reset Delay | 0-7200s | 0s |
| Reset Attempts | 0-10 | 0 |
| Reset Trips | All resettable trips | - |
| Trip Free Time | 0-7200s | 600s |

| Monitor Parameters (R/O) | |
|-------------------------------------|---------|
| PNU | Range |
| Auto Reset Pending | 0-1 |
| Auto Reset Exceeded | 0-1 |
| Auto Reset Delay Remaining | 0-7200s |
| Auto Reset Attempts Remaining | 0-10 |
| Auto Reset Trip Free Time Remaining | 0-7200s |

Notes
 The controller is powered down between t3 and t8 (yellow shaded region)
 During this time controller is unable to make the calculations in real time
 To overcome this the calculations are made retrospectively at time t8
 Start signal state saved at power down and loaded at power up. **This means it will start without a start signal being present**
 If the time to re-establish the power exceeds (Reset Delay x Reset Attempts) to Auto Reset terminates
 (1) Seperate reset signal not available on all products

Operation

Auto Reset Timing Diagrams (continued)

Fig 5.6.5 Auto Reset - Two Wire – Overload

The timing diagrams show the auto reset with a maintained two wire control system
 The fault shown is an overload trip, the Control Supply maintained
 In this instance the Auto Reset clears the trip but the overload (%) will take a certain amount of time to decay
 If insufficient time is left before re-starts the overload will trip again repeatably until the Reset Attempts count exceeds its set value.
 This must be considered and enough time left to allow the overload to decay to a low level

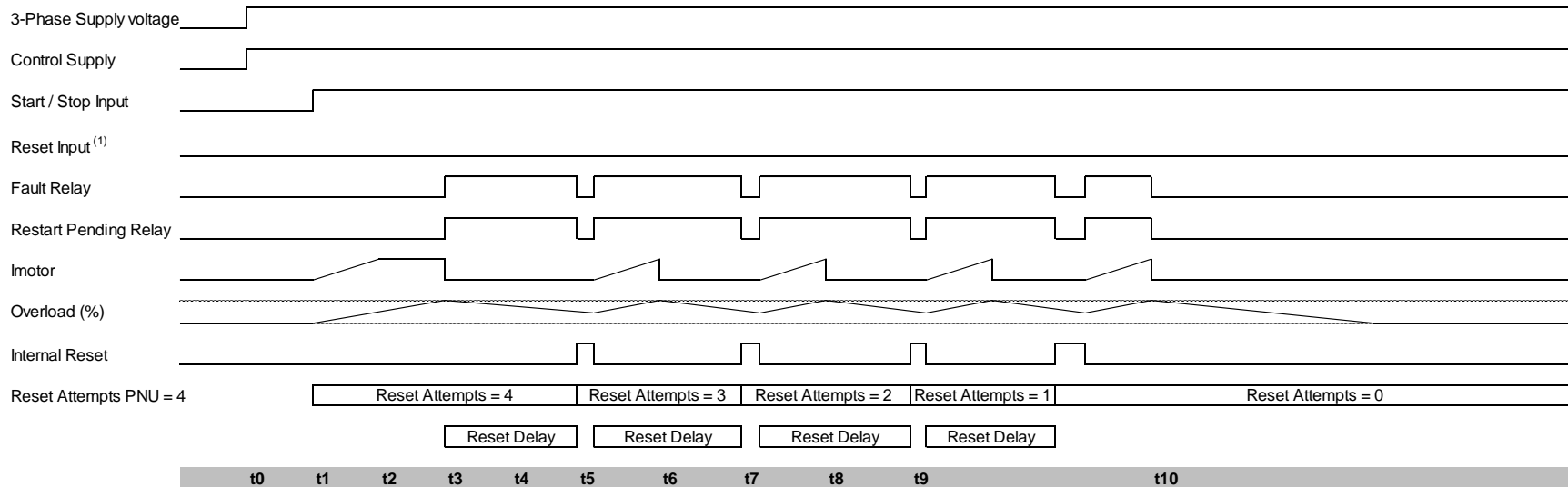

| Sequence of events | |
|--------------------|--|
| t0 | 3 phase supply applied |
| t1 | Start signal applied, motor starts |
| t2 | Motor reaches full voltage |
| t3 | 3 phase supply removed |
| t4 | Start signal must still be applied If it has been removed Auto Reset feature re-initialises |
| t5 | Reset delay = 0 Restart Attempts = 3 Reset Signal must be low If the trip is reset the Auto Reset feature re-initialises |
| t7 | Reset delay = 0 Restart Attempts = 2 |
| t8 | 3-Phase re-established |
| t9 | Reset delay = 0 Restart Attempts = 1 |
| t10 | Trip Free Delay = 0 Restart Attempts = 0 |

| User Parameters (R/W) | | |
|-----------------------|----------------------|---------|
| PNU | Range | Default |
| Auto Reset | Off / On | Off |
| Reset Delay | 0-7200s | 0s |
| Reset Attempts | 0-10 | 0 |
| Reset Trips | All resettable trips | - |
| Trip Free Time | 0-7200s | 600s |

| Monitor Parameters (R/O) | |
|-------------------------------------|---------|
| PNU | Range |
| Auto Reset Pending | 0-1 |
| Auto Reset Exceeded | 0-1 |
| Auto Reset Delay Remaining | 0-7200s |
| Auto Reset Attempts Remaining | 0-10 |
| Auto Reset Trip Free Time Remaining | 0-7200s |

Notes
 In this instance the starter has failed to Auto Restart in the set number of attempts
 The starter will remain in the tripped state until reset
 To overcome this the Reset Delay time should be extended to allow the overload to cool
 For Two Wire control reset occurs automatically when the start signal changes state from low to high, reset shown is programmable reset input ⁽¹⁾

Operation

5.7 Parameters for Touchscreen Interface

5.7.1 'Advanced' Category

| Group | Parameter | Units | Range | Read/Write | Modbus | | Default Setting | User Setting |
|--------------------|---|-------------|---|------------|--------|------|-----------------|--------------|
| | | | | | Dec | Hex | | |
| Save Parameters | | N/A | NO/YES | R/W | 62144 | F2C0 | NO | |
| Automatic Settings | Automatic Pedestal | N/A | OFF/ON | R/W | 19840 | 4D80 | OFF | |
| | Automatic Ramp | N/A | OFF/ON | R/W | 20352 | 4F80 | OFF | |
| | Automatic End Start (1) | N/A | OFF/ON | R/W | 19968 | 4E00 | OFF | |
| | Automatic Stop | N/A | OFF/ON | R/W | 20160 | 4EC0 | OFF | |
| | Automatic Stop Profile | % | 0 to 100 | R/W | 20608 | 5080 | 50 | |
| | Automatic End Stop | N/A | OFF/ON | R/W | 20416 | 4FC0 | OFF | |
| | Automatic Impact Load | N/A | OFF/ON | R/W | 20480 | 5000 | OFF | |
| | Auto Smooth Stop | N/A | OFF/ON | R/W | 20224 | 4F00 | OFF | |
| | Auto Smoothing Level | % | 10 to 100 | R/W | 20672 | 50C0 | 50 | |
| | Automatic End Start (2) | N/A | OFF/ON | R/W | 19904 | 4DC0 | OFF | |
| | – Automatic End Start (3) | N/A | OFF/ON | R/W | 20032 | 4E40 | OFF | |
| | – Rate End Start (3) | % | 0 to 100 | R/W | 768 | 0300 | 75 | |
| Start Settings | Start Time | s | 1 to 300 | R/W | 7104 | 1BC0 | 10 | |
| | Start Pedestal | % | 10 to 100 | R/W | 704 | 02C0 | 20 | |
| | Start Current Limit → Start Current Limit Trip | N/A | OFF/ON | R/W | 53790 | D21E | ON | |
| | Start Current Limit → Start Current Limit Level | A | 50% motor FLA to 450% VMX-Synergy Plus™ rated A | R/W | 26880 | 6900 | 350% motor FLA | |
| | Start Current Limit → Start Current Limit Time | s | 1 to 600 | R/W | 26944 | 6940 | 30 | |
| | Kick Start → Kick Start | N/A | OFF/ON | R/W | 320 | 0140 | OFF | |
| | Kick Start → Kick Start Time | ms | 10 to 2,000 | R/W | 7040 | 1B80 | 100 | |
| | Kick Start → Kick Start Pedestal | % | 30 to 80 | R/W | 640 | 0280 | 75 | |
| Contactor Delay | ms | 20 to 60000 | R/W | 8320 | 2080 | 160 | | |
| Stop Settings | Stop Time | s | 0 to 300 | R/W | 7296 | 1C80 | 0 | |
| | Stop Pedestal | % | 10 to 40 | R/W | 896 | 0380 | 10 | |
| | Stop Current Limit → Stop Current Limit Trip | N/A | OFF/ON | R/W | 53791 | D21F | OFF | |
| | Stop Current Limit → Stop Current Limit Level | A | 100% mtr FLA to 450% VMX-Synergy Plus™ rated A | R/W | 28800 | 7080 | 350% mtr FLA | |
| | Stop Current Limit → Stop Current Limit Time | s | 1 to 300 | R/W | 28864 | 70C0 | 10 | |

Operation

5.7.1 'Advanced' Category (continued)

| Group | Parameter | Units | Range | Read/Write | Modbus | | Default Setting | User Setting |
|-------------------------|---|-------|---|------------|--------|------|--------------------------|--------------|
| | | | | | Dec | Hex | | |
| Motor Protection | Motor Current | A | 10% to 100% of VMX-Synergy Plus™ rated A | R/W | 25728 | 6480 | 100% | |
| | Trip Class | class | 10, 20, 30 | R/W | 25664 | 6440 | 10 | |
| | Low Current Settings → Low Current Trip | N/A | OFF/ON | R/W | 53787 | D21B | OFF | |
| | Low Current Settings → Low Current Trip Level | A | 25% to 100% of motor FLA | R/W | 26304 | 66C0 | 25% | |
| | Low Current Settings → Low Current Trip Time | ms | 100 to 9,000 | R/W | 26368 | 6700 | 100 | |
| | Shearpin Settings → Shearpin Trip | N/A | OFF/ON | R/W | 53793 | D221 | ON | |
| | Shearpin Settings → Shearpin Trip Current | A | 100% mtr FLA to 450% VMX-Synergy Plus™ rated A | R/W | 27584 | 6BC0 | 350% VMX-Synergy Plus™ A | |
| | Shearpin Settings → Shearpin Trip Time | ms | 100 to 9,000 | R/W | 27648 | 6C00 | 100 | |
| | Overload Settings → Overload Trip | N/A | OFF/ON | R/W | 53792 | D220 | ON | |
| | Overload Settings → Overload Level | N/A | 50% to 125% of motor FLA | R/W | 28224 | 6E40 | 115% | |
| | Dynamic Reset | N/A | OFF/ON | R/W | 448 | 1C0 | OFF | |
| | Trip Class Run | N/A | OFF/ON | R/W | 384 | 180 | OFF | |
| | Trip Class Run Value | % | 10 / 20 / 30 | R/W | 25668 | 6444 | 10 | |
| iERS | iERS | N/A | OFF/ON | R/W | 21120 | 5280 | OFF | |
| | Dwell Time | s | 1 to 300 | R/W | 7360 | 1CC0 | 5 | |
| | iERS Rate | % | 0 to 100 | R/W | 21184 | 52C0 | 25 | |
| | iERS Level | % | 0 to 100 | R/W | 21376 | 5380 | 100 | |
| | Fixed Voltage | V | 100 to 1000 | R/W | 35200 | 8980 | 400 | |
| | Fixed Voltage | N/A | OFF/ON | R/W | 35264 | 89C0 | OFF | |
| Control | Control Method | – | Local Touch Screen User Programmable Two Wire Control Three Wire Control Modbus | R/W | 59392 | E800 | Local Touch Screen | |

Operation

5.7.1 'Advanced' Category (continued)

| Group | Parameter | Units | Range | Read/Write | Modbus | | Default Setting | User Setting |
|------------------------|---------------------------|--------|------------------|------------|--------|------|-----------------|--------------|
| | | | | | Dec | Hex | | |
| Trip Settings | Trip Sensitivity | % | 0 to 100 | R/W | 44864 | AF40 | 0 | |
| | Keypad Trip | N/A | OFF/ON | R/W | 53765 | D205 | ON | |
| | Shearpin Trip | N/A | OFF/ON | R/W | 53793 | D221 | ON | |
| | Overload Trip | N/A | OFF/ON | R/W | 53792 | D220 | ON | |
| | Low Current Trip | N/A | OFF/ON | R/W | 53787 | D21B | OFF | |
| | Start Current Limit Trip | N/A | OFF/ON | R/W | 53790 | D21E | ON | |
| | Stop Current Limit Trip | N/A | OFF/ON | R/W | 53791 | D21F | OFF | |
| | PTC Motor Thermistor Trip | N/A | OFF/ON | R/W | 53794 | D222 | OFF | |
| | L1-L2-L3 Trip | N/A | OFF/ON | R/W | 53808 | D230 | OFF | |
| | L1-L3-L2 Trip | N/A | OFF/ON | R/W | 53807 | D22F | OFF | |
| | Remote Start Trip | N/A | OFF/ON | R/W | 53804 | D22C | ON | |
| | Current Sensor Trip | N/A | OFF/ON | R/W | 53775 | D20F | OFF | |
| | Fan Trip | N/A | OFF/ON | R/W | 53782 | D216 | ON | |
| | Communications Trip | N/A | OFF/ON | R/W | 53796 | D224 | ON | |
| | Shut Down (1) | N/A | OFF/ON | R/W | 53769 | D209 | ON | |
| | Shut Down (2) | N/A | OFF/ON | R/W | 53770 | D20A | ON | |
| | Thyristor Firing Trip | N/A | OFF/ON | R/W | 53774 | D20E | ON | |
| | Motor Side Phase Loss | N/A | OFF/ON | R/W | 53777 | D211 | ON | |
| | Sensing Fault Trip | N/A | OFF/ON | R/W | 53781 | D215 | ON | |
| | Thermal Sensor Trip | N/A | OFF/ON | R/W | 53768 | D208 | ON | |
| External Trip | N/A | OFF/ON | R/W | 53795 | D223 | ON | | |
| Operation 1 Trip | N/A | OFF/ON | R/W | 53799 | D227 | OFF | | |
| Operation 2 Trip | N/A | OFF/ON | R/W | 53800 | D228 | ON | | |
| Input Side Phase Loss | N/A | OFF/ON | R/W | 53762 | D202 | ON | | |
| Voltage Imbalance Trip | N/A | OFF/ON | R/W | 53766 | D206 | OFF | | |
| | Firing Mode | N/A | IN-LINE/IN-DELTA | R/W | 128 | 80 | In-Line | |
| Legacy Mode | Legacy Delta Mode | N/A | OFF/ON | R/W | 192 | C0 | OFF | |
| | Legacy OL Display | N/A | OFF/ON | R/W | 193 | C1 | OFF | |
| | Legacy 3 | N/A | OFF/ON | R/W | 194 | C2 | ON | |
| | Legacy 4 | N/A | OFF/ON | R/W | 195 | C3 | OFF | |
| | Legacy 5 | N/A | OFF/ON | R/W | 196 | C4 | OFF | |

Operation

5.7.1 'Advanced' Category (continued)

| Group | Parameter | Units | Range | Read/Write | Modbus | | Default Setting | User Setting |
|----------------|------------------------|--------|-----------|------------|--------|------|-----------------|--------------|
| | | | | | Dec | Hex | | |
| Auto Reset | Auto Reset | N/A | OFF/ON | R/W | 20736 | 5100 | Off | |
| | Reset Delay | s | 0 to 7200 | R/W | 20737 | 5101 | 0 | |
| | Reset Attempts | N/A | 0 to 10 | R/W | 20738 | 5102 | 0 | |
| | Trip Free Time | s | 0 to 7200 | R/W | 20739 | 5103 | 600 | |
| | Input Side Phase Loss | N/A | OFF/ON | R/W | 20801 | 5141 | ON | |
| | Motor Side Phase Loss | N/A | OFF/ON | R/W | 20804 | 5144 | ON | |
| | Overload | N/A | OFF/ON | R/W | 20813 | 514D | ON | |
| | Thyristor Firing | N/A | OFF/ON | R/W | 20803 | 5143 | ON | |
| | Sensing Fault | N/A | OFF/ON | R/W | 20807 | 5147 | ON | |
| | Thermal | N/A | OFF/ON | R/W | 20802 | 5142 | ON | |
| | Low Current | N/A | OFF/ON | R/W | 20811 | 514B | ON | |
| | Current Limit time Out | N/A | OFF/ON | R/W | 20812 | 514C | ON | |
| | Shearpin | N/A | OFF/ON | R/W | 20814 | 514E | ON | |
| | Current Sensor | N/A | OFF/ON | R/W | 20823 | 5157 | ON | |
| | Control Voltage Low | N/A | OFF/ON | R/W | 20806 | 5146 | ON | |
| | Fan | N/A | OFF/ON | R/W | 20808 | 5148 | ON | |
| | External | N/A | OFF/ON | R/W | 20816 | 5150 | ON | |
| | Communications | N/A | OFF/ON | R/W | 20817 | 5151 | ON | |
| | Bypass | N/A | OFF/ON | R/W | 20818 | 5152 | ON | |
| | PTC Thermistor | N/A | OFF/ON | R/W | 20815 | 514F | OFF | |
| Phase Rotation | N/A | OFF/ON | R/W | 20821 | 5155 | OFF | | |
| Operation 1 | N/A | OFF/ON | R/W | 20826 | 515A | ON | | |
| Operation 2 | N/A | OFF/ON | R/W | 20822 | 5156 | ON | | |
| Operation 4 | N/A | OFF/ON | R/W | 20826 | 515A | ON | | |
| Operation 5 | N/A | OFF/ON | R/W | 20824 | 5158 | ON | | |

Operation

5.7.2 'Input/Output' (I/O) Category

| Group | Parameter | Units | Range | Read / Write | Modbus | | Default Setting | User Setting |
|--|---|--------|---|--------------|--------|------|--------------------|--------------|
| | | | | | Dec | Hex | | |
| Digital Inputs | Digital Input Voltage | V | 230Vac, 110Vac or 24Vdc | R/W | 10880 | 2A80 | 230Vac | |
| | Control Method | – | Local Touch Screen User Programmable Two Wire Control Three Wire Control Modbus | R/W | 59392 | E800 | Local Touch Screen | |
| | Digital Input 1 (D1-1I) → Select Function | – | Off Start/Stop Freeze Ramp Reset iERS External Trip | R/W | 10944 | 2AC0 | Start/ Stop | |
| | Digital Input 1 (D1-1I) → High Input =1 if On | N/A | OFF/ON | R/W | 11264 | 2C00 | ON | |
| | Digital Input 2 (D1-2I) → Select Function | – | same as DI-1I function selections | R/W | 10945 | 2AC1 | OFF | |
| | Digital Input 2 (D1-2I) → High Input =1 if On | N/A | OFF/ON | R/W | 11266 | 2C02 | ON | |
| | Digital Input 3 (D2-1I) → Select Function | – | same as DI-1I function selections | R/W | 10946 | 2AC2 | Reset | |
| | Digital Input 3 (D2-1I) → High Input =1 if On | N/A | OFF/ON | R/W | 11268 | 2C04 | ON | |
| | Digital Input 4 (D2-2I) → Select Function | – | same as DI-1I function selections | R/W | 10947 | 2AC3 | OFF | |
| | Digital Input 4 (D2-2I) → High Input =1 if On | N/A | OFF/ON | R/W | 11270 | 2C06 | ON | |
| Digital Outputs | Digital Output 1 N/C (12) → Select Function (DO1) | – | Off Ready Enabled Error Running End of Start Current Limit iERS Active Auto Reset Pending Auto Reset Exceeded Shearpin Low Current | R/W | 11584 | 2D40 | Error | |
| | Digital Output 1 N/C (12) → High Output =1 if On | N/A | OFF/ON | R/W | 11904 | 2E80 | ON | |
| | Digital Output 2 N/O (24) → Select Function (DO2) | – | same as DO1 function selections | R/W | 11585 | 2D41 | Error | |
| | Digital Output 2 N/O (24) → High Output =1 if On | N/A | OFF/ON | R/W | 11906 | 2E82 | ON | |
| | Digital Output 3 N/O (34) → Select Function (DO3) | – | same as DO1 function selections | R/W | 11586 | 2D42 | Running | |
| Digital Output 3 N/O (34) → High Output =1 if On | N/A | OFF/ON | R/W | 11908 | 2E84 | ON | | |

Operation

5.7.2 'Input/Output' (I/O) Category (continued)

| Group | Parameter | Units | Range | Read/Write | Modbus | | Default Setting | User Setting |
|------------------------------------|---|-------|--|------------|--------|------|-----------------|--------------|
| | | | | | Dec | Hex | | |
| Digital Outputs (continued) | Digital Output 4 N/O (44) → Select Function (DO4) | – | same as DO1 function selections | R/W | 11587 | 2D43 | End Of Start | |
| | Digital Output 4 N/O (44) → High Output =1 if On | N/A | OFF/ON | R/W | 11910 | 2E86 | ON | |
| | Digital Output 5 N/O (54) → Select Function (DO5) | – | same as DO1 function selections | R/W | 11588 | 2D44 | Running | |
| | Digital Output 5 N/O (54) → High Output =1 if On | N/A | OFF/ON | R/W | 11912 | 2E88 | ON | |
| Analog Inputs | Analog Input Type | N/A | 0–10V/4–20mA | R/W | 9600 | 2580 | 0–10V | |
| | Select Function | – | Off Current Limit Start Current Shearpin Current Overload | R/W | 9664 | 25C0 | OFF | |
| | Scaling Level | – | Dependent on selected function | R/W | 9728 | 2600 | 16,384 | |
| Analog Outputs | Analog Output Type | N/A | 0–10V/4–20mA | R/W | 8960 | 2300 | 0–10V | |
| | Select Function | – | Off I Measured Overload P-Total | R/W | 9024 | 2340 | OFF | |
| | Scaling Level | – | Dependent on selected function | R/W | 9088 | 2380 | 0 | |
| | PTC Motor Thermistor Trip | – | OFF/ON | R/W | 53794 | D222 | OFF | |

Operation

5.7.3 'Monitor' Category

| Group | Parameter | Units | Range | Read/Write | Modbus | | Default Setting | User Setting |
|------------|---------------------------|--------|----------------------|------------|--------|------|-----------------|--------------|
| | | | | | Dec | Hex | | |
| Monitoring | Line Frequency | Hz | 45 to 65 | Read | 32000 | 7D00 | n/a | – |
| | Phase Rotation | – | L1-L2-L3 or L1-L3-L2 | Read | 32064 | 7D40 | L1-L2-L3 | – |
| | I1 | A | 0 to 10,000 | Read | 33536 | 8300 | 0 | – |
| | I2 | A | 0 to 10,000 | Read | 33538 | 8302 | 0 | – |
| | I3 | A | 0 to 10,000 | Read | 33540 | 8304 | 0 | – |
| | Current I rms | A | 0 to 10,000 | Read | 32896 | 8080 | 0 | – |
| | V1 | V | 0 to 1000 | Read | 33920 | 8480 | 0 | - |
| | V2 | V | 0 to 1000 | Read | 33921 | 8481 | 0 | - |
| | V3 | V | 0 to 1000 | Read | 33922 | 8482 | 0 | - |
| | Voltage Vrms | V | 0 to 1000 | Read | 32960 | 80C0 | 0 | – |
| | HeatSink Temp | °C | -20°C to 80°C | Read | 36544 | 8EC0 | ambient | – |
| | Real Power Factor | – | 0 to 1 | Read | 33024 | 8100 | 0 | – |
| | True Power P | kW | 0 to 10,000 | Read | 34688 | 8780 | 0 | – |
| | Apparent Power S | kVA | 0 to 10,000 | Read | 34816 | 8800 | 0 | – |
| | Reactive Power Q | kVAR | 0 to 10,000 | Read | 34944 | 8880 | 0 | – |
| | iERS Saving Level | % | 0 to 100 | Read | 35008 | 88C0 | 0 | – |
| | Delay Angle | degree | 0° to 55° | Read | 22400 | 5780 | 0 | – |
| | Backstop | degree | 0° to 55° | Read | 23040 | 5A00 | 0 | – |
| | Delay Max | degree | 0° to 55° | Read | 22464 | 57C0 | 0 | – |
| | Pres PF Degrees | degree | 0° to 90° | Read | 21824 | 5540 | 0 | – |
| | Ref PF Degrees | degree | 0° to 90° | Read | 21760 | 5500 | 0 | – |
| | Start Saving Level | % | 50% to 80% of mtr | Read | 21320 | 5348 | 80% | – |
| | Last Peak (Start) Current | A | 0 to 10,000 | Read | 38400 | 9600 | 0 | – |
| | Motor Thermistor | – | 0 to 1024 | Read | 10432 | 28C0 | 0 | – |
| | Overload | % | 0 to 100 | Read | 33408 | 8280 | 0 | – |
| | Restart Pending | N/A | YES/NO | Read | 37376 | 9200 | NO | – |
| | Restarts Exceeded | N/A | YES/NO | Read | 37568 | 92C0 | NO | – |
| | Reset Delay | s | 0 to 7200 | R/W | 20737 | 5101 | 0 | – |
| | Reset Attempts | N/A | 0 to 10 | R/W | 20738 | 5102 | 0 | – |
| | Trip Free Time | s | 0 to 7200 | R/W | 20739 | 5103 | 600 | – |
| | Trip Event | N/A | 100 to 2700 | Read | 20867 | 5183 | 0 | – |
| | Dynamic Reset | % | 0 to 100 | Read | 33409 | 8281 | 0 | – |

Operation

5.7.4 'Log' Category

| Group | Parameter | Units | Range | Read/Write | Modbus | | Default Setting | User Setting |
|-------------------|----------------------------|-------|-------------|------------|--------|------|-----------------|--------------|
| | | | | | Dec | Hex | | |
| Trip Log | Last Trip | – | 0 to 65,535 | Read | 60608 | ECC0 | 0 | – |
| | Last Trip -1 | – | 0 to 65,535 | Read | 60609 | ECC1 | 0 | – |
| | Last Trip -2 | – | 0 to 65,535 | Read | 60610 | ECC2 | 0 | – |
| | Last Trip -3 | – | 0 to 65,535 | Read | 60611 | ECC3 | 0 | – |
| | Last Trip -4 | – | 0 to 65,535 | Read | 60612 | ECC4 | 0 | – |
| | Last Trip -5 | – | 0 to 65,535 | Read | 60613 | ECC5 | 0 | – |
| | Last Trip -6 | – | 0 to 65,535 | Read | 60614 | ECC6 | 0 | – |
| | Last Trip -7 | – | 0 to 65,535 | Read | 60615 | ECC7 | 0 | – |
| | Last Trip -8 | – | 0 to 65,535 | Read | 60616 | ECC8 | 0 | – |
| | Last Trip -9 | – | 0 to 65,535 | Read | 60617 | ECC9 | 0 | – |
| Start Current Log | Last Peak Start Current | A | 0 to 10,000 | Read | 38400 | 9600 | 0 | – |
| | Last Peak Start Current -1 | A | 0 to 10,000 | Read | 38402 | 9602 | 0 | – |
| | Last Peak Start Current -2 | A | 0 to 10,000 | Read | 38404 | 9604 | 0 | – |
| | Last Peak Start Current -3 | A | 0 to 10,000 | Read | 38406 | 9606 | 0 | – |
| | Last Peak Start Current -4 | A | 0 to 10,000 | Read | 38408 | 9608 | 0 | – |
| | Last Peak Start Current -5 | A | 0 to 10,000 | Read | 38410 | 960A | 0 | – |
| | Last Peak Start Current -6 | A | 0 to 10,000 | Read | 38412 | 960C | 0 | – |
| | Last Peak Start Current -7 | A | 0 to 10,000 | Read | 38414 | 960E | 0 | – |
| | Last Peak Start Current -8 | A | 0 to 10,000 | Read | 38416 | 9610 | 0 | – |
| | Last Peak Start Current -9 | A | 0 to 10,000 | Read | 38418 | 9610 | 0 | – |

Operation

5.7.4 'Log' Category (continued)

| Group | Parameter | Units | Range | Read/Write | Modbus | | Default Setting | User Setting |
|------------------|---------------------------|-------|--------------------|------------|--------|------|-----------------|--------------|
| | | | | | Dec | Hex | | |
| Stop Current Log | Last Peak Stop Current | A | 0 to 10,000 | Read | 39040 | 9880 | 0 | – |
| | Last Peak Stop Current -1 | A | 0 to 10,000 | Read | 39042 | 9882 | 0 | – |
| | Last Peak Stop Current -2 | A | 0 to 10,000 | Read | 39044 | 9884 | 0 | – |
| | Last Peak Stop Current -3 | A | 0 to 10,000 | Read | 39046 | 9886 | 0 | – |
| | Last Peak Stop Current -4 | A | 0 to 10,000 | Read | 39048 | 9888 | 0 | – |
| | Last Peak Stop Current -5 | A | 0 to 10,000 | Read | 39050 | 988A | 0 | – |
| | Last Peak Stop Current -6 | A | 0 to 10,000 | Read | 39052 | 988C | 0 | – |
| | Last Peak Stop Current -7 | A | 0 to 10,000 | Read | 39054 | 988E | 0 | – |
| | Last Peak Stop Current -8 | A | 0 to 10,000 | Read | 39056 | 9890 | 0 | – |
| | Last Peak Stop Current -9 | A | 0 to 10,000 | Read | 39058 | 9892 | 0 | – |
| Temperature Log | Last Temperature | °C | -20°C to 80°C | Read | 39680 | 9B00 | ambient | – |
| | Last Temperature -1 | °C | -20°C to 80°C | Read | 39681 | 9B01 | ambient | – |
| | Last Temperature -2 | °C | -20°C to 80°C | Read | 39682 | 9B02 | ambient | – |
| | Last Temperature -3 | °C | -20°C to 80°C | Read | 39683 | 9B03 | ambient | – |
| | Last Temperature -4 | °C | -20°C to 80°C | Read | 39684 | 9B04 | ambient | – |
| | Last Temperature -5 | °C | -20°C to 80°C | Read | 39685 | 9B05 | ambient | – |
| | Last Temperature -6 | °C | -20°C to 80°C | Read | 39686 | 9B06 | ambient | – |
| | Last Temperature -7 | °C | -20°C to 80°C | Read | 39687 | 9B07 | ambient | – |
| | Last Temperature -8 | °C | -20°C to 80°C | Read | 39688 | 9B08 | ambient | – |
| | Last Temperature -9 | °C | -20°C to 80°C | Read | 39689 | 9B09 | ambient | – |
| Overload Log | Last Overload | % | 0 to 100 | Read | 40320 | 9D80 | 0 | – |
| | Last Overload -1 | % | 0 to 100 | Read | 40321 | 9D81 | 0 | – |
| | Last Overload -2 | % | 0 to 100 | Read | 40322 | 9D82 | 0 | – |
| | Last Overload -3 | % | 0 to 100 | Read | 40323 | 9D83 | 0 | – |
| | Last Overload -4 | % | 0 to 100 | Read | 40324 | 9D84 | 0 | – |
| | Last Overload -5 | % | 0 to 100 | Read | 40325 | 9D85 | 0 | – |
| | Last Overload -6 | % | 0 to 100 | Read | 40326 | 9D86 | 0 | – |
| | Last Overload -7 | % | 0 to 100 | Read | 40327 | 9D87 | 0 | – |
| | Last Overload -8 | % | 0 to 100 | Read | 40328 | 9D88 | 0 | – |
| | Last Overload -9 | % | 0 to 100 | Read | 40329 | 9D89 | 0 | – |
| Totals Log | Number of Starts | – | 0 to 4,294,836,225 | Read | 35840 | 8C00 | 0 | – |
| | Motor Running Time | – | 0 to 4,294,836,225 | Read | 35904 | 8C40 | 0 | – |
| | Control Supply On Time | – | 0 to 4,294,836,225 | Read | 35606 | 8C42 | 0 | – |
| | Download Log File | – | – | R/W | n/a | n/a | – | – |
| | Clear Trip Log | – | – | R/W | n/a | n/a | – | – |







Operation

5.7.5 'Device' Category

| Group | Parameter | Units | Range | Read/ Dec | Modbus | | Default Setting | User Setting |
|----------------|-----------------------------|-----------------------------|--|--------------|--------|-------|--------------------|-----------------|
| | | | | | Dec | Hex | | |
| | Update Firmware | – | – | R/W | – | – | – | |
| | Date | – | current date | R/W | – | – | – | |
| | Time | hh:mm:ss | GMT/local | R/W | 14720 | 3980 | GMT | |
| | Language | – | refer to the "Parameter Details" section for list of available languages | R/W | - | - | English | |
| | Passcode | – | 0 to 255 per Byte | R/W | - | - | n/a | |
| | Backlight Timeout | s | 0 to 3,600 | R/W | - | - | 60 | |
| Network | Modbus Network Address | – | 1 to 32 | R/W | 16000 | 3E80 | 1 | |
| | Modbus Network Baud Rate | Baud | 9,600 19,200 38,400 57,600 115,200 | R/W | 16064 | 3EC0 | 19,200 | |
| | Modbus Network Parity | – | none/odd/even | R/W | 16128 | 3F00 | even | |
| | Modbus Network Traffic LEDs | N/A | OFF/ON | R/W | 14080 | 3700 | OFF | |
| | Anybus/ModbusTCP/EtherNetIP | – | Address Serial Number Firmware Version Connection | Read | – | – | – | – |
| | Timeout | ms | 0 to 60,000 | R/W | 15808 | 3DC0 | 5,000 | |
| | Reset Defaults | – | Yes/No | R/W | 62080 | F280 | No | |
| | About | – | VMX-Synergy Plus™ model #, serial #, software versions | Read | – | – | – | – |
| | Screen Lock | N/A | OFF/ON | R/W | – | – | OFF | |
| | Date Format | – | dd/mm/yyyy mm/dd/yyyy | R/W | – | – | dd/mm/yyyy | |
| | Temperature Format | degrees | °C/°F | R/W | – | – | °C | |
| | Parameters to USB | | Yes/No | R/W | – | – | No | |
| | Parameters from USB | | Yes/No | R/W | – | – | No | |
| | Service Code | for manufacturer's use only | | | | 13120 | 3340 | |

Operation

5.8 Auto Setup Menu

| Menu | Description | Min | Max | Default | Unit | Reg. Type |
|---|--|------------------|------------------|------------------|------|------------|
| PNU 19200 Auto Setup   Application: | <p>The Unit has numerous preset applications built in as standard.</p> <p>Select the application best suited to the motor load.</p> <p>The selected application will automatically change several parameters and functions.</p> <p>Depending on the application loaded the "Trip Class" may also change.</p> <p>Refer to the Full User Manual for more details..</p> | Default | End of list | Default | | Read/Write |
| PNU 25664 Auto Setup   Trip Class | <p>The Trip Class is a numeric value that correlates the trip time with overload level.</p> <p>Select Trip Class according to application requirements.</p> <p>The trip time depends on the selected Trip Class. The duration of the overload and the level of the over current.</p> <p>Refer to the Motor Overload 'cold' trip curves given in the Quick Start Guide.</p> <p>When "Class 20" or "Class30" are selected the Unit current rating (i-Unit) will be reduced to a lower value (i-rated).</p> | Trip Class 10 | Trip Class 30 | Trip Class 10 | | Read/Write |
| PNU 25728 Auto Setup   Motor Current | <p>This should be set to the Full Load Current shown on the motor plate.</p> <p>The overload works with multiples of the set "Motor Current" (i-motor).</p> <p>Also referred to as Motor FLA (I-motor)</p> | 10% I-unit | 100% I-rated | 100% I-rated | A | Read/Write |

Operation

5.8 Auto Setup Menu (continued)

| Menu | Description | Min | Max | Default | Unit | Reg. Type |
|--|---|--------------------|--------|--------------------|------|------------|
| <p>PNU 59392</p> <p>Auto Setup</p> <p style="text-align: center;">↓</p> <p style="text-align: center;">↓</p> <p>Control Method</p> | <p>Local Touch Screen : Control using the buttons on the keypad.</p> <p>User Programmable : Control using the terminals. Function defined in "I/O" menu.</p> <p>Two Wire Control : Control using terminals. Functions fixed as shown on screen.</p> <p>Three Wire Control : Control using terminals. Functions fixed as shown on screen.</p> <p>Modbus Network : Control via remote Modbus network or Modbus TCP</p> | Local Touch Screen | Modbus | Local Touch Screen | | Read/Write |
| <p>PNU 10880</p> <p>Auto Setup</p> <p style="text-align: center;">↓</p> <p style="text-align: center;">↓</p> <p>Digital Input Voltage</p> | <p>The digital inputs D1-1I D1-2I D2-1I D2-2I are designed to work with a range of control supplies</p> <p>230V : 'Active high level' Input voltage must be in the range 195.5V - 253V</p> <p>110V : 'Active high level' Input voltage must be in the range 93.5V - 132V</p> <p>24V : 'Active high level ' input voltage must be in the range 20.4V-26.4V</p> <p> It is important to ensure the "Digital input Voltage" corresponds to the voltage applied to the input. Failure to do so may result in damage</p> | 230V | 24Vdc | 230V | | Read/Write |





Operation

5.9 Advanced Menu

| Menu | Description | Min | Max | Default | Unit | Reg. Type |
|---|---|-----|-----|---------|------|------------|
| PNU 62144 Advanced ↓ ↓ Save Parameters | Saves all Read /Write parameters to non volatile memory Yes : Parameters are permanently written No : Parameters remain changed until next power cycle | No | Yes | No | | Read/Write |
| PNU 19840 Advanced Automatic Settings ↓ Automatic Pedestal | Automatically controls the starting torque. On: The initial torque is increased until the motor starts to rotate at a moderate speed. Off: The initial torque is defined by the "Start Pedestal". | Off | On | Off | | Read/Write |
| PNU 20352 Advanced Automatic Settings ↓ Automatic Ramp | Automatically controls the torque applied to the motor during the soft start. On: The torque is adjusted to suit the load. Off: The ramp time depends on the "Start Time" and "Current Limit". | Off | On | Off | | Read/Write |
| PNU 19968 Advanced Automatic Settings ↓ Automatic End Start (1) | Automatically controls the time taken for the motor to start. On : The ramp time is shortened if the motor is at speed before the end of the "Start Time" Off: The ramp time depends on the "Start Time" and "Current Limit" | Off | On | Off | | Read/Write |
| PNU 20160 Advanced Automatic Settings ↓ Automatic Stop | Automatically controls the soft stop to suit the application. This feature is particularly useful with pumping applications. On: If the motor is lightly loaded it decelerates rapidly to the point where the soft stop becomes useful. Off: The deceleration to the point where the soft stop becomes useful, will be slower. | Off | On | Off | | Read/Write |





Operation

5.9 Advanced Menu (continued)

| Menu | Description | Min | Max | Default | Unit | Reg. Type |
|---|---|-----|-----|---------|------|------------|
| PNU 20608 Advanced Automatic Settings  Automatic Stop Profile | Adjusts the response of the "Automatic Stop" Increase if the motor speed doesn't drop quickly enough. . When the value is set to zero the "Automatic Stop" is effectively disabled | 0 | 100 | 50 | % | Read/Write |
| PNU 20416 Advanced Automatic Settings  Automatic End Stop | Automatically controls the "Stop Time" On : The ramp time is shortened if the motor reaches a very low speed before the end of the "Stop Time" Off: The ramp time " depends on the "Stop Time" and "Current Limit" | Off | On | Off | | Read/Write |
| PNU 20480 Advanced Automatic Settings  Automatic Impact Load | Automatically controls the maximum iERS saving level. On : The maximum iERS saving level ("BackStop") is reset to maximum during each load cycle. Off : The saving potential may be reduced on applications with heavy load cycles. Such as injection moulding machines. | Off | On | Off | | Read/Write |
| PNU 20224 Advanced Automatic Settings  Auto Smooth Stop | Automatically controls the soft stop to eliminate oscillations that can occur towards the end of the ramp On : The soft stop is adjusted when oscillations are detected. Refer to "Auto smoothing Level" Off : The soft stop is unadjusted and torque fluctuations may cause instability. This can often occur in pumping applications. | Off | On | Off | | Read/Write |
| PNU 20672 Advanced Automatic Settings  Auto Smoothing Level | Adjusts the response of the "Automatic smoothing" Increase to provide a greater smoothing effect If there are torque fluctuations that occur during the soft stop. When set to zero the smoothing is effectively disabled. | 10 | 100 | 50 | % | Read/Write |

Operation

5.9 Advanced Menu (continued)

| Menu | Description | Min | Max | Default | Unit | Reg. Type |
|---|---|-----|-----|---------|------|------------|
| PNU 19904 Advanced Automatic Settings  Automatic End Start (2) | Automatically controls the time taken for the motor to start On : The ramp time is shortened if torque fluctuations occur before the end of the "Start Time" Off: The ramp time depends on the "Start Time" and "Current Limit" | Off | On | Off | | Read/Write |
| PNU 20032 Advanced Automatic Settings  Automatic End Start (3) | Automatically controls the time taken for the motor to start On : The ramp time is shortened if torque fluctuations occur before the end of the "Start Time" Off: The ramp time depends on the "Start Time" and "Current Limit" | Off | On | Off | | Read/Write |
| PNU 768 Advanced Automatic Settings  Rate End Start (3) | Adjusts the response of the "Automatic End Start (3)" Increase to provide a greater smoothing effect If there are torque fluctuations that occur during the soft start. When set to zero the smoothing is effectively disabled. | 0 | 100 | % | | Read/Write |
| PNU 7104 Advanced Start Settings  Start Time | Time taken to soft start from the "Start Pedestal" to the end of the start Normally set between 5 and 30 seconds. Actual time to get to full voltage depends on the "Start Current Limit Level". If set too long the motor can be at speed before the end of the time set. Refer to "Automatic End Start" | 1 | 300 | 10 | s | Read/Write |
| PNU 704 Advanced Start Settings  Start Pedestal | Percentage of the supply voltage applied to motor at the beginning of the soft start. Increase to provide more torque If the load fails to break away. Decrease if the motor accelerates too quickly. | 10 | 100 | 20 | % | Read/Write |



Operation

5.9 Advanced Menu (continued)

| Menu | Description | Min | Max | Default | Unit | Reg. Type |
|--|--|-------------|-------------|--------------|------|------------|
| PNU 53790 Advanced Start Settings Start Current Limit Start Current Limit Trip | <p>Selects trip or continue if the current limit has been active for too long.</p> <p>On: The Unit will trip.</p> <p>Off: The start will continue regardless of the motor current level.</p> | Off | On | On | | Read/Write |
| PNU 26880 Advanced Start Settings Start Current Limit Start Current Limit Level | <p>The current in Amps at which the soft Start ramp is held.</p> <p>Normally set to 350% of motor FLC. Increase if motor fails to accelerate at required rate.</p> <p>The "Current Limit Level" will affect actual time to start. If set too low the motor may not accelerate to full speed.</p> | 50% I-motor | 450% I-unit | 350% I-motor | A | Read/Write |
| PNU 26944 Advanced Start Settings Start Current Limit Start Current Limit Time | <p>The maximum time allowed for the current limit.</p> <p>If the current limit is still active at the end of this period, the Unit will either 'Trip' or 'continue'.</p> | 1 | 600 | 30 | s | Read/Write |
| PNU 320 Advanced Start Settings Kick Start Kick Start | <p>Applies a short duration torque pulse to dislodge 'sticky' loads</p> <p>On : The torque pulse is applied at start-up when complete the torque drops to the "Start Pedestal"</p> <p>Off: The initial starting torque is defined by the "Start Pedestal"</p> | Off | On | Off | | Read/Write |
| PNU 7040 Advanced Start Settings Kick Start Kick Start Time | <p>Time that the torque pulse is applied to load</p> <p>Increase to provide more torque If the load fails to break away.</p> <p>Decrease if the motor accelerates too quickly.</p> | 10 | 2000 | ms | | Read/Write |



Operation

5.9 Advanced Menu (continued)

| Menu | Description | Min | Max | Default | Unit | Reg. Type |
|--|---|-----|-------|---------|------|------------|
| PNU 640 Advanced Start Settings Kick Start Kick Start Pedestal | <p>Percentage of the supply voltage applied to the motor during the 'kick' period.</p> <p>Increase to provide more torque If the load fails to break away.</p> <p>Decrease if the motor accelerates too quickly.</p> | 30 | 80 | 75 | % | Read/Write |
| PNU 8320 Advanced Start Settings  Contactor Delay | <p>Time allowed for external contactors to close.</p> <p>Increase if contactors are driven by buffer relays or motor trips on phase loss when start signal applied.</p> <p>Decrease if response to start signal needs to be improved.</p> | 20 | 60000 | 160 | ms | Read/Write |
| PNU 7296 Advanced Stop Settings  Stop Time | <p>The time taken to soft stop from full voltage or the iERS level to the 'Stop Pedestal'.</p> <p>Normally set between 15 and 60 seconds. Actual time to get to 'Stop Pedestal' depends on the "Stop Current Limit Level".</p> <p>If set too long the motor may reach zero speed before the end of the time set. Refer to "Automatic End Stop".</p> | 0 | 300 | 0 | s | Read/Write |
| PNU 896 Advanced Stop Settings  Stop Pedestal | <p>Percentage of the supply voltage applied to the motor at the end of the soft stop.</p> <p>Increase if the motor crawls at the end of the soft stop.</p> <p>Decrease if a greater soft-stop effect is required at the end of the ramp.</p> | 10 | 40 | 10 | % | Read/Write |
| PNU 53791 Advanced Stop Settings Stop Current Limit Stop Current Limit Trip | <p>Selects trip or continue if the stop current limit has been active for too long.</p> <p>On: The Unit will trip.</p> <p>Off: The stop will continue regardless of the motor current level.</p> | Off | On | Off | | Read/Write |

Operation

5.9 Advanced Menu (continued)

| Menu | Description | Min | Max | Default | Unit | Reg. Type |
|---|---|---------------|---------------|---------------|------|------------|
| PNU 28800 Advanced Stop Settings Stop Current Limit Stop Current Limit Level | <p>The current in Amps at which the soft stop ramp is not allowed to go above.</p> <p>Normally set to 350% motor FLC. Increase if motor decelerates too rapidly.</p> <p>The current limit level will affect actual time to stop the motor.</p> | 100% I-motor | 450% I-unit | 350% I-motor | A | Read/Write |
| PNU 28864 Advanced Stop Settings Stop Current Limit Stop Current Limit Time | <p>The maximum time allowed for the current limit.</p> <p>If the current limit is still active at the end of this period, the Unit will either trip or continue.</p> | 1 | 300 | 10 | s | Read/Write |
| PNU 25728 Advanced Motor Protection  Motor Current | <p>This should be set to the Full Load Current shown on the motor plate.</p> <p>The overload works with multiples of the set "Motor Current" (i-motor).</p> <p>Also referred to as Motor FLA (I-motor).</p> | 10% I-unit | 100% I-rated | 100% I-rated | A | Read/Write |
| PNU 25664 Advanced Motor Protection  Trip Class | <p>The trip class is a numeric value that correlates the trip time with overload level.</p> <p>Select Trip class according to application requirements.</p> <p>The trip time depends on the selected Trip Class. The duration of the overload and the level of the over current.</p> <p>Refer to the Motor Overload 'cold' trip curves given in the Quick Start Guide.</p> <p>When "Class 20" or "Class 30" are selected the Unit current rating (i-Unit) will be reduced to a lower value (i-rated).</p> | Trip Class 10 | Trip Class 30 | Trip Class 10 | | Read/Write |





Operation

5.9 Advanced Menu (continued)

| Menu | Description | Min | Max | Default | Unit | Reg. Type |
|--|--|--------------|--------------|--------------|------|------------|
| PNU 53787 Advanced Motor Protection Low Current Settings Low Current Trip | <p>This can be used to detect if the motor is running lightly loaded.</p> <p>On: The Unit will trip. This feature is not active during soft start and soft stop.</p> <p>Off: The Unit will continue to operate regardless of motor current.</p> | Off | On | Off | | Read/Write |
| PNU 26304 Advanced Motor Protection Low Current Settings Low Current Trip Level | <p>The current in Amps that will cause a trip.</p> <p>A trip will occur if the motor current is less than the "Trip Level" for the "Trip Time".</p> | 25% I-motor | 100% I-motor | 25% I-motor | A | Read/Write |
| PNU 26368 Advanced Motor Protection Low Current Settings Low Current Trip Time | <p>The trip time for the Low current trip.</p> <p>A trip will occur if the motor current is less than the "Trip Level" for the "Trip Time".</p> | 100 | 9000 | 100 | ms | Read/Write |
| PNU 53793 Advanced Motor Protection Shearpin Settings Shearpin Trip | <p>The shearpin is an electronic equivalent of a mechanical shearpin.</p> <p>On : The Unit will trip. This feature is not active during soft start, dwell period and soft stop.</p> <p>Off: The Unit will continue to operate regardless of motor current level.</p> | Off | On | On | | Read/Write |
| PNU 27584 Advanced Motor Protection Shearpin Settings Shearpin Trip Current | <p>The current in Amps that will cause a "Shearpin Trip".</p> <p>A trip will occur if the motor current is greater than the "Trip Level" for the "Trip Time".</p> | 100% I-motor | 450% I-motor | 350% I-motor | A | Read/Write |
| PNU 27648 Advanced Motor Protection Shearpin Settings Shearpin Trip Time | <p>The trip time for the Shearpin trip.</p> <p>A trip will occur if the motor current is greater than the "Trip Level" for the "Trip Time".</p> | 100 | 9000 | 100 | ms | Read/Write |





Operation

5.9 Advanced Menu (continued)

| Menu | Description | Min | Max | Default | Unit | Reg. Type |
|--|--|-------------|--------------|--------------|------|------------|
| PNU 53792 Advanced Motor Protection Overload Settings Overload Trip | <p>The Unit has an "Overload" function that is an electronic equivalent to a thermal overload.</p> <p>On : The Unit will trip when the "Overload" level (ModbusPNU 33408) exceeds 100%</p> <p>Off: The Unit will continue to operate regardless of motor current level. Not recommended.</p> | Off | On | On | | Read/Write |
| PNU 28224 Advanced Motor Protection Overload Settings Overload Level | <p>Determines the level in Amps at which the overload will start.</p> <p>Normally set to 115% of the set motor current (i-motor).</p> <p>Reduce to speed up trip response.</p> | 50% I-motor | 125% I-motor | 115% I-motor | A | Read/Write |
| PNU 21120 Advanced iERS  iERS | <p>Enables and disables the intelligent Energy Recovery System feature (iERS).</p> <p>On: The voltage to the motor will be regulated to ensure optimum efficiency.</p> <p>Off: The feature is disabled, and the motor operates at full voltage. Internal bypass closed.</p> | Off | On | Off | | Read/Write |
| PNU 448 Advanced  Dynamic Reset | <p>Dynamically tracks the thermal capacity needed for a successful restart after an overload trip. It averages the thermal capacity consumed in the previous three successful starts and calculates a thermal capacity to Start.</p> <p>On: If there is insufficient capacity to start the unit it will be "inhibited" from starting.</p> <p>Off: If there is insufficient capacity to start the unit it will not be "inhibited" from starting</p> | Off | On | Off | | Read/Write |
| PNU 384 Advanced  Motor Protection  Overload Settings  Trip Class Run | <p>This feature is only available for ANSI models.</p> <p>When selected it allows it allows a different overload class to be selected during the running period.</p> <p>Off: The overload will use the "Trip Class" selection when starting "Trip Class Run Value" selection when running.</p> <p>On: The overload will use the "Trip Class" selection for starting and running.</p> | Off | On | Off | | Read/Write |





Operation

5.9 Advanced Menu (continued)

| Menu | Description | Min | Max | Default | Unit | Reg. Type |
|--|---|------------------|------------------|------------------|------|------------|
| PNU 25668 Advanced  Motor Protection  Overload Settings  Trip Class Run Value | <p>This feature is only available for ANSI models.</p> <p>When selected it allows a different overload class to be selected during the running period.</p> <p>The trip time depends on the selected run trip class value, the duration of the overload and the level of the overcurrent.</p> | Trip Class 10 | Trip Class 30 | Trip Class 10 | | Read/Write |
| PNU 7360 Advanced iERS  Dwell Time | <p>The time from the End of the start to the point where the iERS saving mode becomes active.</p> <p>Normally set to 5 seconds to ensure the motor is at full speed before the iERS saving becomes active,</p> <p>Increase to allow time for the motor to stabilise.</p> | 1 | 300 | 5 | s | Read/Write |
| PNU 21184 Advanced iERS  iERS Rate | <p>Determines the rate at which the load is regulated during the iERS energy saving mode.</p> <p>During periods of instability the "Current Irms" and "True Power Factor" will oscillate rapidly.</p> <p>Increase if the application shows signs of instability.</p> <p>Reduce to increase the speed of response.</p> | 0 | 100 | 25 | % | Read/Write |





Operation

5.9 Advanced Menu (continued)

| Menu | Description | Min | Max | Default | Unit | Reg. Type |
|--|---|--------------------|----------------|--------------------|------|------------|
| PNU 21376 Advanced iERS  iERS Level | Determines the maximum energy saving potential. Reduce if the application shows signs of instability. The amount of energy that can be saved may fall as the "iERS level" is reduced. | 0 | 100 | 100 | % | Read/Write |
| PNU 35200 Advanced iERS  Fixed Voltage | User settable voltage level for power calculations If a very high level of accuracy is required the user can input the 3-Phase voltage directly | 100 | 500 | 100 | V | Read/Write |
| PNU 35264 Advanced iERS  Fixed Voltage | Selects the source for the voltage value used in the power calculations. on: KW KVar and KVA are calculated using the "Fixed Voltage". off: KW KVar and KVA are calculated using the internally measured voltage. | Off | On | Off | | Read/Write |
| PNU 59392 Advanced   Control Method | Local Touch Screen : Control using the buttons on the keypad. User Programmable : Control using the terminals. Function defined in "I/O" menu. Two Wire Control : Control using terminals. Functions fixed as shown on screen. Three Wire Control : Control using terminals. Functions fixed as shown on screen. Modbus Network : Control via remote Modbus network or Modbus TCP | Local Touch Screen | Modbus Network | Local Touch Screen | | Read/Write |





Operation

5.9 Advanced Menu (continued)

| Menu | Description | Min | Max | Default | Unit | Reg. Type |
|---|---|-----|-----|---------|------|------------|
| PNU 44864 Advanced Trip Settings  Trip Sensitivity | Adjusts the reaction time to fault trips. Increase "Trip Sensitivity" to slow the response to fault trips. Sometimes useful on sites where electrical noise is causing nuisance tripping. This is a global setting. Increasing "Trip Sensitivity" will slow the response of nearly all the trips. | 0 | 100 | 0 | % | Read/Write |
| PNU 53765 Advanced Trip Settings  Keypad Trip | Detects if the communications bus has failed or become inactive between the keypad and the main unit. On :Keypad trip enabled. Off : Keypad trip disabled. | Off | On | On | | Read/Write |
| PNU 53793 Advanced Trip Settings  Shearpin Trip | The shearpin is an electronic equivalent of a mechanical shearpin. On : The Unit will trip. This feature is not active during soft start, dwell period and soft stop. Off: The Unit will continue to operate regardless of motor current level. | Off | On | On | | Read/Write |
| PNU 53792 Advanced Trip Settings  Overload Trip | The Unit has an "Overload" function that is an electronic equivalent to a thermal overload. On: The Unit will trip when the "Overload" capacity (ModbusPNU 33408) exceeds 100%. Off: The Unit will continue to operate regardless of motor current level. | Off | On | On | | Read/Write |





Operation

5.9 Advanced Menu (continued)

| Menu | Description | Min | Max | Default | Unit | Reg. Type |
|--|---|-----|-----|---------|------|------------|
| PNU 53787 Advanced Trip Settings  Low Current Trip | <p>This can be used to detect if the motor is running lightly loaded.</p> <p>On: The Unit will trip. This feature is not active during soft start and soft stop.</p> <p>Off: The Unit will continue to operate regardless of motor current.</p> | Off | On | Off | | Read/Write |
| PNU 53790 Advanced Trip Settings  Start Current Limit Trip | <p>Selects trip or continue if the current limit has been active for too long.</p> <p>On: The Unit will trip.</p> <p>Off: The start will continue regardless of the motor current level.</p> | Off | On | On | | Read/Write |
| PNU 53791 Advanced Trip Settings  Stop Current Limit Trip | <p>Selects trip or continue if the stop current limit has been active for too long.</p> <p>On: The Unit will trip.</p> <p>Off: The stop will continue regardless of the motor current level.</p> | Off | On | Off | | Read/Write |
| PNU 53794 Advanced Trip Settings  PTC Motor Thermistor Trip | <p>A single PTC motor thermistor or set of PTC motor thermistors can be connected to the PTC terminals.</p> <p>On: The Unit will trip if the motor thermistor exceeds its response temperature or the PTC input is open circuit.</p> <p>Off: The unit will not trip regardless of motor rotation.</p> | Off | On | Off | | Read/Write |
| PNU 53808 Advanced Trip Settings  L1-L2-L3 Trip | <p>Determines if supply phase sequence is incorrect for motor rotation.</p> <p>On: Trips if the phase sequence is L1-L2-L3.</p> <p>Off: The unit will not trip regardless of motor rotation.</p> | Off | On | Off | | Read/Write |



Operation

5.9 Advanced Menu (continued)

| Menu | Description | Min | Max | Default | Unit | Reg. Type |
|--|---|-----|-----|---------|------|------------|
| PNU 53807 Advanced Trip Settings  L1-L3-L2 Trip | <p>Determines if supply phase sequence is incorrect for motor rotation.</p> <p>On: Trips if the phase sequence is L1-L3-L2.</p> <p>Off: The unit will not trip regardless of motor rotation.</p> | Off | On | Off | | Read/Write |
| PNU 53804 Advanced Trip Settings  Remote Start Trip | <p>For safety reasons the Unit will trip during some operations if the remote start signal is active.</p> <p>On: Trips if the remote start signal is active when the Unit is powered up or a reset is applied.</p> <p>Off: The Unit will not trip and may start unexpectedly if the start signal is accidentally left active.</p> | Off | On | On | | Read/Write |
| PNU 53775 Advanced Trip Settings  Current Sensor Trip | <p>Detects if the internal current sensors have failed or reading a very low level.</p> <p>On: The Unit will trip if the internal current sensors fail or the current measured falls to a very low level.</p> <p>Off: Will continue to operate even if the sensor has failed. Measurements and overload protection may be affected.</p> | Off | On | Off | | Read/Write |
| PNU 53782 Advanced Trip Settings  Fan Trip | <p>Detects if the cooling fans have failed.</p> <p>On: The Unit trips if the cooling fans fitted to the Unit fail.</p> <p>Off : The unit will continue to operate and is likely to trip on a thermal trip as the heatsink will not be sufficiently cooled</p> | Off | On | On | | Read/Write |

Operation

5.9 Advanced Menu (continued)

| Menu | Description | Min | Max | Default | Unit | Reg. Type |
|--|---|-----|-----|---------|------|------------|
| PNU 53796 Advanced Trip Settings  Communications Trip | Detects if the communications bus has failed or become inactive. To keep the bus active there must be at least one Modbus read or write (any PNU) during the "Timeout ms" period (ModbusPNU 15808). On: Communication trip enabled. Off: Communication trip disabled. | Off | On | On | | Read/Write |
| PNU 53769 Advanced Trip Settings  Shut Down (1) | This controls the soft stop improve stability On: The stop time is truncated if the motor experiences severe torque fluctuations during the soft stop. Off: Follows normal soft stop time. | Off | On | On | | Read/Write |
| PNU 53770 Advanced Trip Settings  Shut Down (2) | This feature controls the soft stop improve stability. On: The stop time is truncated if the motor experiences severe torque fluctuations during the soft stop. Off: Follows normal soft stop time. | Off | On | On | | Read/Write |



The Shut Down Trips are in operation during the soft stop ramp.

At the end of the soft stop ramp, occasionally the motor can become unstable due to torque fluctuations.

If the torque fluctuations get too bad then VMX-Synergy Plus™ may trip, this could cause issues with the restart. With Shut Down Trips turned on, if the torque fluctuations are experienced VMX-Synergy Plus™ will automatically stop the soft stop ramp and let the motor coast to a full stop. This stops VMX-Synergy Plus™ tripping and allows for a restart without resetting a trip. This is normally only for a very small time due to torque fluctuations occurring at the end of a soft stop ramp. If a Shut Down occurs, then it is logged in the log file but will not affect the operation of VMX-Synergy Plus™. Both shut down trips have to do with rapid changes in power factor. Soft stop smoothing will keep shut down trips from happening.





Operation

5.9 Advanced Menu (continued)

| Menu | Description | Min | Max | Default | Unit | Reg. Type |
|---|---|-----|-----|---------|------|------------|
| <p>PNU 53774 Advanced Trip Settings</p> <p style="text-align: center;">↓</p> <p>Thyristor Firing Trip</p> | <p>Detects if there is a fault with one or more of the internal Thyristors or bypass relays.</p> <p>On: Trips if one or more of the Thyristors/bypass relays has failed short circuit. ISOLATE SUPPLY.</p> <p>Check by measuring the resistance between L1 -T1 L2 -T2 L3 -T3 (Anything < 10R is assumed short circuit).</p> <p>Off (not recommended): The Unit will attempt to start and run although the operation may be erratic.</p> <p>Operating in this mode for prolonged periods may result in SCR failure.</p> | Off | On | On | | Read/Write |
| <p>PNU 53777 Advanced Trip Settings</p> <p style="text-align: center;">↓</p> <p>Motor Side Phase Loss</p> | <p>Detects if there is a disconnection between the Unit output and the motor.</p> <p>On: Trips if there is a disconnection between the output side of the Unit and the motor.</p> <p>Off: The Unit will attempt to start and run although the operation may be erratic.</p> <p>Operating in this mode for prolonged periods may result in SCR failure.</p> | Off | On | On | | Read/Write |
| <p>PNU 53781 Advanced Trip Settings</p> <p style="text-align: center;">↓</p> <p>Sensing Fault Trip</p> | <p>Detects if there is a fault with operation of one or more of the internal Thyristors.</p> <p>On: Trips if one or more of the Thyristors fails to turn on properly.</p> <p>Off: The Unit will attempt to start and run although the operation may be erratic.</p> <p>Operating in this mode for prolonged periods may result in SCR failure.</p> | Off | On | On | | Read/Write |

Operation

5.9 Advanced Menu (continued)

| Menu | Description | Min | Max | Default | Unit | Reg. Type |
|--|--|-----|-----|---------|------|------------|
| PNU 53768 Advanced Trip Settings  Thermal Sensor Trip | <p>Detects if the internal temperature sensor has malfunctioned.</p> <p>On: The Unit will trip if the internal temperature sensor malfunctions.</p> <p>Off: The Unit will continue to operate even if the temperature sensor has malfunctioned.</p> <p>Operating in this mode for prolonged periods may result in SCR failure.</p> | Off | On | On | | Read/Write |
| PNU 53795 Advanced Trip Settings  External Trip | <p>Allows a trip to be forced using one of the digital inputs.</p> <p>On: Trips when the programmed input is active.</p> <p>Off: External Trip is disabled.</p> | Off | On | On | | Read/Write |
| PNU 53799 Advanced Trip Settings  Operation 1 Trip | <p>Detects if the logging function has failed to operate normally.</p> <p>On : Operation 1 trip enabled. (Trip Code 2601-2699)</p> <p>Off: Operation 1 trip disabled.</p> | Off | On | Off | | Read/Write |
| PNU 53800 Advanced Trip Settings  Operation 2 Trip | <p>Detects if the Control Board has failed to operate normally.</p> <p>On : Operation 2 trip enabled. (Trip Code 2401-2499)</p> <p>Off: Operation 2 trip disabled.</p> | Off | On | On | | Read/Write |

Operation

5.9 Advanced Menu (continued)







| | | | | | |
|---|--|---------|----------|---------|------------|
| <p>PNU 53762 Advanced Trip Settings</p> <p style="text-align: center;">↓</p> <p>Input Side Phase Loss</p> | <p>Detects if there is a disconnection between the unit input and the three-phase supply when the motor is running.</p> <p>Advanced Trip Settings >>>>>>>> Input Side Phase Loss</p> <p>On : Trips if there is a disconnection between the input side of the unit and the three-phase supply when the motor is running.</p> <p>Off : The Unit will attempt to run although the operation may be erratic.</p> <p>Operating in this mode for prolonged periods may result in SCR failure</p> | Off | On | On | Read/Write |
| <p>PNU 53766 Advanced Trip Settings</p> <p style="text-align: center;">↓</p> <p>Voltage Imbalance Trip</p> | <p>Detects if there is an imbalance between the phases on the incoming three-phase supply</p> <p>On : Trips if there is an imbalance in the incoming three-phase supply.</p> <p>Off : The Unit will attempt to run although the operation may be erratic.</p> <p>Operating in this mode for prolonged periods may result in SCR failure</p> | Off | On | On | Read/Write |
| <p>PNU 128 Advanced</p> <p style="text-align: center;">↓</p> <p style="text-align: center;">↓</p> <p>Firing Mode</p> | <p>Set to correspond with Unit connection to the Motor.</p> <p>Refer to connection diagrams.</p> <p>In-Line: The Unit is connected in-line with a delta or star connected motor.</p> <p>In-Delta: The Unit is connected inside the Delta of the motor. The iERS function is disabled.</p> | In-Line | In-Delta | In-Line | Read/Write |
| <p>PNU 192 Advanced</p> <p style="text-align: center;">↓</p> <p style="text-align: center;">↓</p> <p>Legacy Delta Mode</p> | <p>Allows the Unit to be retro-fitted into "Delta" applications that previously used QFE/XFE (5MC).</p> <p>On: Operates in QFE/XFE (5MC) delta compatibility mode.</p> <p>Off: Operates normally. Refer to Unit Delta connection diagram in the Quick Start Guide.</p> | Off | On | Off | Read/Write |

Operation

| | | | | | | |
|--|---|-----|----|-----|--|------------|
| <p>PNU 193</p> | | Off | On | Off | | Read/Write |
| <p>Advanced</p> <p style="text-align: center;">↓</p> <p>Legacy Mode</p> <p style="text-align: center;">↓</p> <p>Legacy OL Display</p> | <p>Allows the overload percentage to be displayed as either 0% through to 100% (IEC Model), or 100% down to 0% (ANSI Model).</p> <p>On: Overload capacity shown is 100% (empty) to 0% (full).</p> <p>Off: Overload capacity is 0% (empty) to 100% (full).</p> | | | | | |
| <p>PNU 194</p> <p style="text-align: center;">↓</p> <p>Legacy Mode</p> <p style="text-align: center;">↓</p> <p>Legacy 3</p> | <p>For Future Development</p> | Off | On | Off | | Read/Write |
| <p>PNU 195</p> <p style="text-align: center;">↓</p> <p>Legacy Mode</p> <p style="text-align: center;">↓</p> <p>Legacy 4</p> | <p>For Future Development</p> | Off | On | Off | | Read/Write |
| <p>PNU 195</p> <p style="text-align: center;">↓</p> <p>Legacy Mode</p> <p style="text-align: center;">↓</p> <p>Legacy 5</p> | <p>For Future Development.</p> | Off | On | Off | | Read/Write |



Operation

5.9 Advanced Menu (continued)

| Menu | Description | Min | Max | Default | Unit | Reg. Type |
|--|---|-----|------|---------|------|------------|
| PNU 14144 Advanced   Main Contactor Control | <p>The unit is configured to start and stop when the main contactor opens and closes.</p> <p>On: When a zero stop time is set some faults will be ignored when main contactor opens.</p> <p>Off : When the contactor opens and the stop signal is given at the same time the unit may trip on "Phase Loss".</p> | Off | On | Off | | Read/Write |
| PNU 28160 Advanced   Hand/Auto Control | <p>A Hand-Auto selection switch can be connected to Digital Input D1-2I to change the 'Control Method'</p> <p>This can be used to change the Start / Stop to 'Hand' if the Communications fails</p> <p>D1-2I = 0 : Control Method is set to "2 -Wire" (Hand)</p> <p>D1-2I = 1 : Control Method is set to "Modbus Network" (Auto)</p> <p>Hand : Input D1-1I = Start / Stop, Input D2-1I = Reset</p> <p>Auto : PNU 17920 = Start / Stop, PNU 18368 = Reset</p> | Off | On | On | | Read/Write |
| PNU 20736 Advanced Auto Reset  Auto Reset | <p>Enables the Auto Reset Feature.</p> <p>On: The Auto Reset feature is Enabled.</p> <p>Off: The Auto Reset feature is disabled and all counters will be re-initialised.</p> | Off | On | Off | | Read/Write |
| PNU 20737 Advanced Auto Reset  Reset Delay | <p>The delay between the trip event and the automatic reset, the unit will re-start following the reset if the start signal is active.</p> <p>If this is set to zero at any point the Auto Reset feature will terminate and the counters will be re-initialised.</p> <p>When the delay is active the Restart Pending parameter is set and the time remaining can be viewed in the monitor menu.</p> | 0 | 7200 | 0 | s | Read/Write |

Operation

5.9 Advanced Menu (continued)

| Menu | Description | Min | Max | Default | Unit | Reg. Type |
|--|---|-----|------|---------|------|------------|
| PNU 20738 Advanced Auto Reset  Reset Attempts | <p>The number of restart attempts allowed before the Auto Reset terminates. If the Auto Reset has been successful, the counter is reset back to its maximum value when the unit has been running fault free for the Trip Free Time.</p> <p>If the Auto Restart has been unsuccessful the counters are re-initialised by applying a reset signal or removing the start signal.</p> <p>If set to zero at any point the Auto Reset feature will terminate and the counters will be re-initialised. The number of attempts remaining can be viewed in the Monitor menu.</p> | 0 | 10 | 0 | | Read/Write |
| PNU 20739 Advanced Auto Reset  Trip Free Time | <p>The time the unit must be run trip free before the counters are re-initialised back to zero.</p> <p>If set to zero at any point the Auto Reset feature will terminate and the counters will be re-initialised.</p> <p>The Trip Free Time can be viewed in the Monitor menu.</p> | 0 | 7200 | 600 | s | Read/Write |
| PNU 20801 Advanced Auto Reset Reset Trips Input Side Phase Loss | <p>Allows the user to select whether the unit will auto reset if a Input Side Phase Loss Trip occurs</p> <p>On : The trip will auto reset when the Reset Delay reaches zero.</p> <p>Off : The trip will not auto reset</p> | Off | On | On | | Read/Write |
| PNU 20804 Advanced Auto Reset Reset Trips Motor Side Phase Loss | <p>Allows the user to select whether the unit will auto reset if a Motor Side Phase Loss Trip occurs</p> <p>On : The trip will auto reset when the Reset Delay reaches zero.</p> <p>Off : The trip will not auto reset</p> | Off | On | On | | Read/Write |

Operation

5.9 Advanced Menu (continued)

| | | | | | | |
|--|---|-----|----|----|--|------------|
| <p>PNU 20813 Advanced Auto Reset Reset Trips Overload</p> | <p>Allows the user to select whether the unit will auto reset if an Overload Trip occurs.</p> <p>On: The trip will auto reset when the Reset Delay reaches zero.</p> <p>Off: The trip will not auto reset.</p> | Off | On | On | | Read/Write |
| <p>PNU 20803 Advanced Auto Reset Reset Trips Thyristor Firing</p> | <p>Allows the user to select whether the unit will auto reset if a Thyristor Firing Trip occurs</p> <p>On: The trip will auto reset when the Reset Delay reaches zero.</p> <p>Off: The trip will not auto reset.</p> | Off | On | On | | Read/Write |
| <p>PNU 20807 Advanced Auto Reset Reset Trips Sensing Fault</p> | <p>Allows the user to select whether the unit will auto reset if a Sensing Fault Trip occurs.</p> <p>On: The trip will auto reset when the Reset Delay reaches zero.</p> <p>Off: The trip will not auto reset.</p> | Off | On | On | | Read/Write |
| <p>PNU 20802 Advanced Auto Reset Reset Trips Thermal</p> | <p>Allows the user to select whether the unit will auto reset if a Thermal Trip occurs</p> <p>On : The trip will auto reset when the Reset Delay reaches zero.</p> <p>Off : The trip will not auto reset</p> | Off | On | On | | Read/Write |
| <p>PNU 20811 Advanced Auto Reset Reset Trips Low Current</p> | <p>Allows the user to select whether the unit will auto reset if a Low Current Trip occurs.</p> <p>On: The trip will auto reset when the Reset Delay reaches zero.</p> <p>Off: The trip will not auto reset.</p> | Off | On | On | | Read/Write |
| <p>PNU 20812 Advanced Auto Reset Reset Trips Current Limit Time Out</p> | <p>Allows the user to select whether the unit will auto reset if a Current Limit Time Out Trip occurs.</p> <p>On: The trip will auto reset when the Reset Delay reaches zero.</p> <p>Off: The trip will not auto reset.</p> | Off | On | On | | Read/Write |

Operation

5.9 Advanced Menu (continued)

| Menu | Description | Min | Max | Default | Unit | Reg. Type |
|--|--|-----|-----|---------|------|------------|
| PNU 20814 Advanced Auto Reset Reset Trips Shearpin | Allows the user to select whether the unit will auto reset if a Shearpin Trip occurs. On: The trip will auto reset when the Reset Delay reaches zero. Off: The trip will not auto reset. | Off | On | On | | Read/Write |
| PNU 20823 Advanced Auto Reset Reset Trips Current sensor | Allows the user to select whether the unit will auto reset if a Current Sensor Trip occurs. On: The trip will auto reset when the Reset Delay reaches zero. Off: The trip will not auto reset. | Off | On | On | | Read/Write |
| PNU 20806 Advanced Auto Reset Reset Trips Control Voltage Low | Allows the user to select whether the unit will auto reset if a Control Voltage Low Trip occurs Advanced Auto Reset Reset Trips Control Voltage Low On : The trip will auto reset when the Reset Delay reaches zero. Off : The trip will not auto reset | Off | On | On | | Read/Write |
| PNU 20808 Advanced Auto Reset Reset Trips Fan | Allows the user to select whether the unit will auto reset if a Fan Trip occurs. On: The trip will auto reset when the Reset Delay reaches zero. Off: The trip will not auto reset. | Off | On | On | | Read/Write |
| PNU 20816 Advanced Auto Reset Reset Trips External | Allows the user to select whether the unit will auto reset if an External Trip occurs. On: The trip will auto reset when the Reset Delay reaches zero. Off: The trip will not auto reset. | Off | On | Off | | Read/Write |
| PNU 20817 Advanced Auto Reset Reset Trips Communications | Allows the user to select whether the unit will auto reset if a Communications Trip occurs. On: The trip will auto reset when the Reset Delay reaches zero. Off: The trip will not auto reset. | Off | On | On | | Read/Write |

Operation

5.9 Advanced Menu (continued)

| Menu | Description | Min | Max | Default | Unit | Reg. Type |
|---|---|-----|-----|---------|------|------------|
| PNU 20818 Advanced Auto Reset Reset Trips Bypass | <p>Allows the user to select whether the unit will auto reset if a Bypass Trip occurs.</p> <p>On: The trip will auto reset when the Reset Delay reaches zero.</p> <p>Off: The trip will not auto reset.</p> | Off | On | Off | | Read/Write |
| PNU 20815 Advanced Auto Reset Reset Trips PTC Thermistor | <p>Allows the user to select whether the unit will auto reset if a PTC Thermistor Trip occurs.</p> <p>On: The trip will auto reset when the Reset Delay reaches zero.</p> <p>Off: The trip will not auto reset.</p> | Off | On | Off | | Read/Write |
| PNU 20821 Advanced Auto Reset Reset Trips Phase Rotation | <p>Allows the user to select whether the unit will auto reset if a Phase Rotation Trip occurs.</p> <p>On: The trip will auto reset when the Reset Delay reaches zero.</p> <p>Off: The trip will not auto reset.</p> | Off | On | On | | Read/Write |
| PNU 20826 Advanced Auto Reset Reset Trips Operation 1 | <p>Allows the user to select whether the unit will auto reset if an Operation 1 Trip occurs</p> <p>On : The trip will auto reset when the Reset Delay reaches zero.</p> <p>Off : The trip will not auto reset</p> | Off | On | On | | Read/Write |
| PNU 20824 Advanced Auto Reset Reset Trips Operation 2 | <p>Allows the user to select whether the unit will auto reset if an Operation 2 Trip occurs.</p> <p>On: The trip will auto reset when the Reset Delay reaches zero.</p> <p>Off: The trip will not auto reset.</p> | Off | On | On | | Read/Write |
| PNU 20822 Advanced Auto Reset Reset Trips Operation 4 | <p>Allows the user to select whether the unit will auto reset if an Operation 4 Trip occurs.</p> <p>On: The trip will auto reset when the Reset Delay reaches zero.</p> <p>Off: The trip will not auto reset.</p> | Off | On | On | | Read/Write |



Operation

5.9 Advanced Menu (continued)

| Menu | Description | Min | Max | Default | Unit | Reg. Type |
|--|--|-----|-----|---------|------|------------|
| PNU 20827 Advanced Auto Reset Reset Trips Operation 5 | Allows the user to select whether the unit will auto reset if an Operation 5 Trip occurs. On: The trip will auto reset when the Reset Delay reaches zero. Off: The trip will not auto reset. | Off | On | On | | Read/Write |

Operation

5.10 Input/Output Menu

| Menu | Description | Min | Max | Default | Unit | Reg. Type |
|--|---|--------------------|-------------|--------------------|------|------------|
| PNU 10880 I/O Digital Inputs  Digital Input Voltage | <p>The digital inputs D1-1I D1-2I D2-1I D2-2I are designed to work with a range of control supplies</p> <p>230V : 'Active high level' Input voltage must be in the range 195.5V - 253V</p> <p>110V : 'Active high level' Input voltage must be in the range 93.5V - 132V</p> <p>24V : 'Active high level' input voltage must be in the range 20.4V-26.4V</p> <p> It is important to ensure the "Digital input Voltage" corresponds to the voltage applied to the input. Failure to do so may result in damage.</p> | 230V | 24Vdc | 230V | | Read/Write |
| PNU 59392 I/O Digital Inputs  Control Method | <p>Local Touch Screen : Control using the buttons on the keypad.</p> <p>User Programmable : Control using the terminals. Function defined in "I/O" menu.</p> <p>Two Wire Control : Control using terminals. Functions fixed as shown on screen.</p> <p>Three Wire Control : Control using terminals. Functions fixed as shown on screen.</p> <p>Modbus RTU : Control via remote Modbus RTU network or Modbus TCP</p> | Local Touch Screen | Modbus RTU | Local Touch Screen | | Read/Write |
| PNU 10944 I/O Digital Inputs Digital Input 1 (D1-1I) Select Function | <p>Allows the Digital input (D1-1I) to be mapped to different functions.</p> <p>The selected function will change in proportion with the input.</p> <p>Digital inputs can only be mapped if the "Control Method" is set to "User Programmable".</p> | Off | End of list | Start/Stop | | Read/Write |

Operation

5.10 Input/Output Menu (continued)

| Menu | Description | Min | Max | Default | Unit | Reg. Type |
|---|--|-----|-------------|---------|------|------------|
| PNU 11264 I/O Digital Inputs Digital Input 1 (D1-1I) High Input = 1 Sets Value | Allows the polarity of the input to be reversed On : When the input is on the selected function will be on. Off : When the input is off the selected function will be on. | Off | On | On | | Read/Write |
| PNU 10945 I/O Digital Inputs Digital Input 2 (D1-2I) Select Function | Allows the Digital input (D1-2I) to be mapped to different functions. The selected function will change in proportion with the input. Digital inputs can only be mapped if the "Control Method" is set to "User Programmable". | Off | End of list | Off | | Read/Write |
| PNU 11266 I/O Digital Inputs Digital Input 2 (D1-2I) High Input = 1 Sets Value | Allows the polarity of the input to be reversed. On: When the input is on the selected function will be on. Off: When the input is off the selected function will be on. | Off | On | On | | Read/Write |
| PNU 10946 I/O Digital Inputs Digital Input 3 (D2-1I) Select Function | Allows the Digital input (D2-1I) to be mapped to different functions. The selected function will change in proportion with the input. Digital inputs can only be mapped if the "Control Method" is set to "User Programmable". | Off | End of list | Reset | | Read/Write |
| PNU 11268 I/O Digital Inputs Digital Input 3 (D2-1I) High Input = 1 Sets Value | Allows the polarity of the input to be reversed. On: When the input is on the selected function will be on. Off: When the input is off the selected function will be on. | Off | On | On | | Read/Write |

Operation

5.10 Input/Output Menu (continued)

| Menu | Description | | Min | Max | Default | Unit | Reg. Type |
|--|---|--|-----|-------------|---------|------|------------|
| PNU 10947 I/O Digital Inputs Digital Input 4 (D2-2I) Select Function | <p>Allows the Digital input (D2-2I) to be mapped to different functions.</p> <p>The selected function will change in proportion with the input.</p> <p>Digital inputs can only be mapped if the "Control Method" is set to "User Programmable".</p> | | Off | End of list | Off | | Read/Write |
| PNU 11270 I/O Digital Inputs Digital Input 4 (D2-2I) High Input = 1 Sets Value | <p>Allows the polarity of the input to be reversed.</p> <p>On: When the input is on the selected function will be on.</p> <p>Off: When the input is off the selected function will be on.</p> | | Off | On | On | | Read/Write |
| PNU 11584 I/O Digital Outputs Digital Output 1 N/C(12) Select Function | <p>Allows the Digital output (N/C (12)) to be mapped to different functions.</p> <p>The digital output will change in accordance with the selected function</p> | | Off | End of list | Error | | Read/Write |
| PNU 11904 I/O Digital Outputs Digital Output 1 N/C(12) High Output = 1 When Value | <p>Allows the polarity of the output to be reversed.</p> <p>On: When the selected function is on the output will be on.</p> <p>Off: When the selected function is on the output is off.</p> | | Off | On | On | | Read/Write |
| PNU 11585 I/O Digital Outputs Digital Output 2 N/O(24) Select Function | <p>Allows the Digital output (N/O (24)) to be mapped to different functions.</p> <p>The digital output will change in accordance with the selected function</p> | | Off | End of list | Error | | Read/Write |
| PNU 11906 I/O Digital Outputs Digital Output 2 N/O(24) High Output = 1 When Value | <p>Allows the polarity of the output to be reversed.</p> <p>On: When the selected function is on the output will be on.</p> <p>Off: When the selected function is on the output is off.</p> | | Off | On | On | | Read/Write |





Operation

5.10 Input/Output Menu (continued)

| Menu | Description | Min | Max | Default | Unit | Reg. Type |
|--|---|-----|-------------|--------------|------|------------|
| PNU 11586 I/O Digital Outputs Digital Output 3 N/O(34) Select Function | <p>Allows the Digital output (N/O (34)) to be mapped to different functions.</p> <p>The digital output will change in accordance with the selected function</p> | Off | End of list | Running | | Read/Write |
| PNU 11908 I/O Digital Outputs Digital Output 3 N/O(34) High Output = 1 When Value | <p>Allows the polarity of the output to be reversed.</p> <p>On: When the selected function is on the output will be on.</p> <p>Off: When the selected function is on the output is off.</p> | Off | On | On | | Read/Write |
| PNU 11587 I/O Digital Outputs Digital Output 4 (N/O(44)) Select Function | <p>Allows the Digital output (N/O (44)) to be mapped to different functions.</p> <p>The digital output will change in accordance with the selected function</p> | Off | End of list | End of Start | | Read/Write |
| PNU 11910 I/O Digital Outputs Digital Output 4 N/O(44) High Output = 1 When Value | <p>Allows the polarity of the output to be reversed.</p> <p>On: When the selected function is on the output will be on.</p> <p>Off: When the selected function is on the output is off.</p> | Off | On | On | | Read/Write |
| PNU 11588 I/O Digital Outputs Digital Output 5(N/O(54)) Select Function | <p>Allows the Digital output (N/O (54)) to be mapped to different functions.</p> <p>The digital output will change in accordance with the selected function</p> | Off | End of list | End of Start | | Read/Write |
| PNU 11912 I/O Digital Outputs Digital Output 5 N/O(54) High Output = 1 When Value | <p>Allows the polarity of the output to be reversed.</p> <p>On: When the selected function is on the output will be on.</p> <p>Off: When the selected function is on the output is off.</p> | Off | On | On | | Read/Write |



Operation

5.10 Input/Output Menu (continued)

| Menu | Description | Min | Max | Default | Unit | Reg. Type |
|--|---|---------|-------------|-----------|------|------------|
| PNU 9600 I/O Analogue Inputs  Analogue Input Type | Defines the function of the analogue input (AI). 0-10V: The input voltage varies from 0-10V. 4-20mA: The input varies from 4 to 20mA. | 0 - 10V | 4 - 20mA | 0 - 10V | | Read/Write |
| PNU 9664 I/O Analogue Inputs  Select Function | Allows the Analogue input to be mapped to different functions The selected function will change in proportion with the input By default the function will be at its maximum when the input is at its maximum | Off | End of List | Off | | Read/Write |
| PNU 9728 I/O Analogue Inputs  Scaling Level | Allows the selected function to be scaled. The selected function will change in proportion with the input. The function will be at its "Scaling Level" when the input is at its maximum. | 0 | Max value | Max value | % | Read/Write |
| PNU 8960 I/O Analogue Outputs  Analogue Output Type | Defines the physical function of the analogue output (AO). 0-10V: The output voltage varies from 0 to 10V. 4-20mA: The output current varies from 4 to 20mA. | 0 - 10V | 4 - 20mA | 0 - 10V | | Read/Write |
| PNU 9024 I/O Analogue Outputs  Select Function | Allows the Analogue output to be mapped to different PNU functions. The output will change in proportion with the selected function. By default, the output will be at a maximum when the selected function equals its maximum value. | Off | End of list | Off | | Read/Write |

Operation

5.10 Input/Output Menu (continued)

| Menu | Description | Min | Max | Default | Unit | Reg. Type |
|--|---|-----|-----------|---------|------|------------|
| PNU 9088 I/O Analogue Outputs  Scaling Level | <p>Allows the selected function to be scaled.</p> <p>The output will change in proportion with the selected function.</p> <p>The output will be at a maximum when the selected function equals the "Scaling Level".</p> | 0 | Max value | 0 | % | Read/Write |
| PNU 53794 I/O   PTC Motor Thermistor Trip | <p>A single PTC motor thermistor or set of PTC motor thermistors can be connected to the PTC terminals.</p> <p>On: The Unit will trip if the motor thermistor exceeds its response temperature or the PTC input is open circuit.</p> <p>Off: The Unit will continue to operate.</p> | Off | On | Off | | Read/Write |

Operation

5.11 Monitor Menu

| Menu | Description | Min | Max | Default | Unit | Reg. Type |
|---|---|----------|----------|----------|------|-----------|
| PNU 32000 Monitor ↓ ↓ Line Frequency | The frequency of the 3-phase supply. | 45 | 65 | - | Hz | Read Only |
| PNU 32064 Monitor ↓ ↓ Phase Rotation | Indicates the phase sequence of the incoming supply. RYB = L1-L2-L3. RBY = L1-L3-L2. | L1-L2-L3 | L1-L3-L2 | L1-L2-L3 | | Read Only |
| PNU 33536 Monitor ↓ ↓ I1 | The RMS current on phase L1. | 0 | 10000 | 0 | A | Read Only |
| PNU 33538 Monitor ↓ ↓ I2 | The RMS current on phase L2. | 0 | 10000 | 0 | A | Read Only |
| PNU 33540 Monitor ↓ ↓ I3 | The RMS current on phase L3. | 0 | 10000 | 0 | A | Read Only |
| PNU 32896 Monitor ↓ ↓ Current Irms | The RMS motor current. This is the maximum of the 3 phases. This value is used for the overload and power calculations. | 0 | 10000 | 0 | A | Read Only |

Operation

5.11 Monitor Menu (continued)

| Menu | Description | Min | Max | Default | Unit | Reg. Type |
|--|---|-----|------|---------|----------|-----------|
| PNU 33920 Monitor ↓ ↓ V1 | The voltage on phase L1 | 0 | 1000 | 0 | V | Read Only |
| PNU 33921 Monitor ↓ ↓ V2 | The voltage on phase L2 | 0 | 1000 | 0 | V | Read Only |
| PNU 33922 Monitor ↓ ↓ V3 | The voltage on phase L3 | 0 | 1000 | 0 | V | Read Only |
| PNU 32960 Monitor ↓ ↓ Voltage Vrms | <p>The RMS 3-phase supply voltage.</p> <p>This is the average of the 3 phases. This value is used for power calculations.</p> <p>This value is derived internally. If a higher level of accuracy is required a "Fixed Voltage" value can be used.</p> | 0 | 1000 | 0 | V | Read Only |
| PNU 36544 Monitor ↓ ↓ HeatSink Temp | <p>The temperature of the internal Unit heatsink.</p> <p>The Unit will trip when the heatsink temperature exceeds 90°C.</p> <p>The internal cooling fans will turn on if this temperature exceeds 40°C.</p> | -20 | 90 | 0 | °C or °F | Read Only |

Operation

5.11 Monitor Menu (continued)

| | | | | | | |
|---|---|---|-------|---|------|-----------|
| <p>PNU 33024 Monitor</p> <p style="text-align: center;">↓ ↓</p> <p>True Power Factor</p> | <p>The True Power Factor = (Displacement Power Factor x Distortion Power Factor)</p> | 0 | 1 | 0 | | Read Only |
| <p>PNU 34688 Monitor</p> <p style="text-align: center;">↓ ↓</p> <p>True Power P</p> | <p>Total true power (Estimated). This is an addition of the 3 phases.</p> | 0 | 10000 | 0 | kW | Read Only |
| <p>PNU 34816 Monitor</p> <p style="text-align: center;">↓ ↓</p> <p>Apparent Power S</p> | <p>Total Apparent Power This is an addition of the 3 phases.</p> | 0 | 10000 | 0 | kVA | Read Only |
| <p>PNU 34944 Monitor</p> <p style="text-align: center;">↓ ↓</p> <p>Reactive Power Q</p> | <p>Total Reactive Power This is an addition of the 3 phases.</p> | 0 | 10000 | 0 | kvar | Read Only |
| <p>PNU 35008 Monitor</p> <p style="text-align: center;">↓ ↓</p> <p>iERS Saving Level</p> | <p>Indicates the level of potential saving. 100% indicates that Unit is saving at its maximum level. Does not indicated real percentage saving.</p> | 0 | 100 | 0 | % | Read Only |
| <p>PNU 22400 Monitor</p> <p style="text-align: center;">↓ ↓</p> <p>Delay Angle</p> | <p>Internal firing delay angle in Degrees. Displayed for diagnostic purposes.</p> | 0 | 60 | 0 | Deg | Read Only |

Operation

5.11 Monitor Menu (continued)

| Menu | Description | Min | Max | Default | Unit | Reg. Type |
|--|---|-----|-----|---------|------|-----------|
| PNU 23040 Monitor ↓ ↓ BackStop | <p>The maximum possible Delay angle for the current iERS saving phase.</p> <p>Displayed for diagnostic purposes.</p> <p>May decrease during heavy load periods or instability.</p> | 0 | 55 | 0 | Deg | Read Only |
| PNU 22464 Monitor ↓ ↓ Delay Max | <p>The maximum possible delay for iERS saving.</p> <p>Displayed for diagnostic purposes.</p> | 0 | 55 | 0 | Deg | Read Only |
| PNU 21824 Monitor ↓ ↓ Pres PF Degrees | <p>The Present Power Factor used by the iERS saving function</p> <p>This is the actual Power Factor for the iERS saving function.</p> <p>The "Delay" is constantly adjusted to minimise the control loop error between "Pres PF Degrees" and "Ref PF Degrees"</p> <p>The parameter displays the displacement part of the True Power Factor and is used for diagnostic purposes.</p> | 0 | 90 | 0 | Deg | Read Only |
| PNU 21760 Monitor ↓ ↓ Ref PF Degrees | <p>The Reference Power Factor used by the iERS saving function</p> <p>This is the target Power Factor for the iERS saving function.</p> <p>The parameter will change dynamically dependant on motor operation</p> <p>The parameter displays the displacement part of the True Power Factor and is used for diagnostic purposes.</p> | 0 | 90 | 0 | Deg | Read Only |

Operation

5.11 Monitor Menu (continued)

| Menu | Description | Min | Max | Default | Unit | Reg. Type |
|--|---|-------------|-------------|-------------|------|-----------|
| <p>PNU 21320</p> <p>Monitor</p> <p style="text-align: center;">↓</p> <p style="text-align: center;">↓</p> <p>Start Saving Level</p> | <p>The current in Amps at which the iERS is enabled or disabled.</p> <p>The iERS function is active when the motor current is less than the "Start Saving Level".</p> <p>When the iERS function is disabled internal bypass relays close to improve efficiency.</p> | 50% I-motor | 80% I-motor | 80% I-motor | A | Read Only |
| <p>PNU 38400</p> <p>Monitor</p> <p style="text-align: center;">↓</p> <p style="text-align: center;">↓</p> <p>Last Peak Current</p> | <p>Displays the peak current of the last successful start.</p> | 0 | 10000 | 0 | A | Read Only |
| <p>PNU 10432</p> <p>Monitor</p> <p style="text-align: center;">↓</p> <p style="text-align: center;">↓</p> <p>Motor Thermistor</p> | <p>Indicates the state of the Unit PTC input. Designed for single or double or triple PTC in series</p> <p>PTC thermistor standards DIN44081 / EN60738-1 apply (< 300R @ 25°C. Typically 4K @ nominal temperature)</p> <p>The value indicated is a not in degrees Celsius but is an internal representation.</p> <p>At 25°C the value displayed should be less than 100 and the Unit trips when value > 400 (open circuit = 1024)</p> <p>The value will increase rapidly when the motor thermistors approach their nominal temperature.</p> <p>If thermistors are connected the "Thermistor trip" should be turned "on"</p> | 0 | 1024 | 1024 | | Read Only |

Operation

5.11 Monitor Menu (continued)

| Menu | Description | Min | Max | Default | Unit | Reg. Type |
|---|--|-----|-----|---------|------|-----------|
| <p>PNU 33408</p> <p>Monitor</p> <p>↓</p> <p>↓</p> <p>Overload</p> | <p>The Unit has an "Overload" function that is an electronic equivalent to a thermal overload.</p> <p>"Overload" displays the overload level which is a measure of how close the Unit to tripping on "Overload Trip"</p> <p>When "Current Irms" is greater than the "Overload Level" the "Overload" increases in accordance with the "Trip Class".</p> <p>When "Current Irms" is less than "Overload Level" the "Overload" decreases exponentially (if greater than 50%)</p> <p>When the "Overload" reaches 100% the Unit will trip.</p> <p>During situations when (i-motor) is equal to (i-Unit) the overload will indicate 50%</p> | 0 | 100 | 0 | % | Read Only |
| <p>PNU 37376</p> <p>Monitor</p> <p>↓</p> <p>↓</p> <p>Auto Reset Pending</p> | <p>Indicates that the Reset Delay counter is counting down.</p> <p>Yes: The Auto Reset Delay is counting down.</p> <p>No: The Auto Reset Delay is not counting down.</p> <p>To map to digital output, refer to PNU11584-PNU11587.</p> | No | Yes | No | | Read Only |
| <p>PNU 37568</p> <p>Monitor</p> <p>↓</p> <p>↓</p> <p>Auto Reset Exceeded</p> | <p>Indicates that the maximum number of reset attempts has been reached.</p> <p>Yes: The number of reset attempts has exceeded the value set.</p> <p>No: The number of reset attempts has not exceeded the value set".</p> <p>To map to digital output, refer to PNU11584-PNU11587.</p> | No | Yes | No | | Read Only |

Operation

5.11 Monitor Menu (continued)

| Menu | Description | Min | Max | Default | Unit | Reg. Type |
|---|---|-----|------|---------|------|-----------|
| PNU 20864 Monitor ↓ ↓ Reset Delay | The amount of time remaining in the Reset Delay counter. | 0 | 7200 | 0 | s | Read Only |
| PNU 20865 Monitor ↓ ↓ Reset Attempts | The number of Reset Attempts remaining. | 0 | 10 | 0 | | Read Only |
| PNU 20866 Monitor ↓ ↓ Trip Free Time | This is the amount of time remaining in the Trip Free Time counter. | 0 | 7200 | 600 | A | Read Only |
| PNU 20867 Monitor ↓ ↓ Trip Event | This is the trip that occurred just prior to the auto reset. | 100 | 2700 | 0 | | Read Only |

Operation

5.11 Monitor Menu (continued)

| Menu | Description | Min | Max | Default | Unit | Reg. Type |
|--|--|-----|-----|---------|------|-----------|
| <p style="text-align: center;"> PNU 33409 Monitor  Dynamic Reset </p> | <p>Dynamically tracks the thermal capacity needed for a successful restart after an overload trip. It averages the thermal capacity consumed in the previous three successful starts and calculates a thermal capacity to start.</p> <p>The calculated thermal capacity is stored in the "Dynamic Reset" register. After tripping on overload, the thermal "Overload" register must have regained the amount recorded in "Dynamic Reset" before a reset will be allowed.</p> <p>If there is insufficient capacity to start the unit it will be inhibited from starting. The unit can be reset when there is sufficient capacity to start and the start stop signal is not present.</p> | 0 | 100 | 0 | % | Read Only |





Operation

5.12 Log Menu

| Menu | Description | Min | Max | Default | Unit | Reg. Type |
|--|-----------------------------------|-----|-------|---------|------|-----------|
| PNU 60608 Log Trip Log ↓ Last Trip | Displays the last Fault trip. | 0 | 65535 | 0 | | Read Only |
| PNU 60609 Log Trip Log ↓ Last Trip -1 | Displays the last Fault trip - 1. | 0 | 65535 | 0 | | Read Only |
| PNU 60610 Log Trip Log ↓ Last Trip -2 | Displays the last Fault trip - 2. | 0 | 65535 | 0 | | Read Only |
| PNU 60611 Log Trip Log ↓ Last Trip -3 | Displays the last Fault trip - 3. | 0 | 65535 | 0 | | Read Only |
| PNU 60612 Log Trip Log ↓ Last Trip -4 | Displays the last Fault trip - 4. | 0 | 65535 | 0 | | Read Only |
| PNU 60613 Log Trip Log ↓ Last Trip -5 | Displays the last Fault trip - 5. | 0 | 65535 | 0 | | Read Only |

Operation

5.12 Log Menu (continued)

| Menu | Description | Min | Max | Default | Unit | Reg. Type |
|---|---|-----|-------|---------|------|-----------|
| PNU 60614 Log Trip Log  Last Trip -6 | Displays the last Fault trip – 6. | 0 | 65535 | 0 | | Read Only |
| PNU 60615 Log Trip Log  Last Trip -7 | Displays the last Fault trip – 7. | 0 | 65535 | 0 | | Read Only |
| PNU 60616 Log Trip Log  Last Trip -8 | Displays the last Fault trip – 8. | 0 | 65535 | 0 | | Read Only |
| PNU 60617 Log Trip Log  Last Trip -9 | Displays the last Fault trip -9. | 0 | 65535 | 0 | | Read Only |
| PNU - Log Trip Log Trip Code Descriptions 101 Input Side Phase Loss | Phase L1 missing at the instant of start up. The L1 phase is either missing or at a very low level. Check all incoming connections. If a main contactor is being controlled by a digital output set to "Running", check contactor delay is sufficient. | | | | | Read Only |

Operation

5.12 Log Menu (continued)

| Menu | Description | Min | Max | Default | Unit | Reg. Type |
|---|--|-----|-----|---------|------|-----------|
| <p>PNU - Log Trip Log Trip Code Descriptions 102 Input Side Phase Loss</p> | <p>Phase L2 missing at the instant of start up.</p> <p>The L2 phase is either missing or at a very low level.</p> <p>Check all incoming connections.</p> <p>If a main contactor is being controlled by a digital output set to "Running", check contactor delay is sufficient.</p> | | | | | Read Only |
| <p>PNU - Log Trip Log Trip Code Descriptions 103 Input Side Phase Loss</p> | <p>Phase L3 missing at the instant of start up.</p> <p>The L3 phase is either missing or at a very low level.</p> <p>Check all incoming connections.</p> <p>If a main contactor is being controlled by a digital output set to "Running" check contactor delay is sufficient.</p> | | | | | Read Only |
| <p>PNU - Log Trip Log Trip Code Descriptions 104 – 117 Input Side Phase Loss</p> | <p>Any or all phases missing when the motor is being controlled.</p> <p>L1 L2 or L3 phase are missing or at a very low level.</p> <p>Check all incoming connections.</p> <p>Check any fuses/breakers incorporated in the power circuit.</p> | | | | | Read Only |
| <p>PNU - Log Trip Log Trip Code Descriptions 150 Voltage Imbalance</p> | <p>The three phase input voltages are imbalanced</p> <p>The maximum voltage is determined and the other voltages are compared to it.</p> <p>Check all incoming connections.</p> <p>Check any fuses / breakers incorporated in the power circuit</p> | | | | | Read Only |

Operation

5.12 Log Menu (continued)

| Menu | Description | Min | Max | Default | Unit | Reg. Type |
|---|--|-----|-----|---------|------|-----------|
| <p>PNU - Log Trip Log Trip Code Descriptions 201 Max. Temp. Exceeded</p> | <p>Internal heatsink temperature has exceeded 90°C.</p> <p>It is possible the Unit is operating outside specified limits.</p> <p>Check enclosure ventilation and airflow around the Unit. If the unit trips immediately the internal temperature sensor could be faulty.</p> | | | | | Read Only |
| <p>PNU - Log Trip Log Trip Code Descriptions 208 Thermal Sensor Trip</p> | <p>Thermal sensor Failure.</p> <p>The internal temperature sensor has failed.</p> <p>Contact the supplier.</p> | | | | | Read Only |
| <p>PNU - Log Trip Log Trip Code Descriptions 301-308 Thyristor Firing Trip</p> | <p>One or more of the internal control thyristors (SCRs) have failed to turn on properly. (In-Line "Firing Mode").</p> <p>The Unit has detected that the SCRs are not operating as expected.</p> <p>Check all incoming and outgoing connections.</p> | | | | | Read Only |
| <p>PNU - Log Trip Log Trip Code Descriptions 350-358 Thyristor Firing Trip</p> | <p>One or more of the internal control thyristors (SCRs) have failed to turn on properly. (Delta "Firing Mode").</p> <p>The Unit has detected that the SCRs are not operating as expected.</p> <p>Check all incoming and outgoing connections.</p> | | | | | Read Only |

Operation

5.12 Log Menu (continued)

| Menu | Description | Min | Max | Default | Unit | Reg. Type |
|--|--|-----|-----|---------|------|-----------|
| PNU - Log Trip Log Trip Code Descriptions 401 Motor Side Phase Loss | <p>One or all of the phases are missing on the motor side during the instant of start up.</p> <p>T1 T2 or T3 phase are missing or at a very low level.</p> <p>Check that the motor is connected to T1 T2 and T3. Ensure any disconnecting device between the Unit and the motor is closed at the instant of start.</p> | | | | | Read Only |
| PNU - Log Trip Log Trip Code Descriptions 402-403 Motor Side Phase Loss | <p>One or all of the phases are missing on the motor side during the instant of start up when the motor being controlled.</p> <p>T1 T2 or T3 phase are missing or at a very low level.</p> <p>Check all incoming and outgoing connections.</p> | | | | | Read Only |
| PNU - Log Trip Log Trip Code Descriptions 601 Control Voltage Too Low | <p>The internal control supply of the Unit level has fallen to a low level.</p> <p>Can be caused by a weak 24Vdc control supply.</p> <p>Ensure 24Vdc supply meets the requirements specified in the Quick Start Guide.</p> | | | | | Read Only |
| PNU - Log Trip Log Trip Code Descriptions 701-710 Sensing Fault Trip | <p>One or more of the internal control thyristors (SCRs) have failed to turn on properly.</p> <p>The Unit has detected that the SCRs are not operating as expected.</p> <p>Check connections all incoming and outgoing connections.</p> | | | | | Read Only |
| PNU - Log Trip Log Trip Code Descriptions 801-802 Fan Problem | <p>One or more of the internal cooling fans has failed.</p> <p>To ensure the heatsink is cooled sufficiently the Unit will trip if the fans fail to operate.</p> <p>Check Unit fans for signs of damage or contamination.</p> | | | | | Read Only |

Operation

5.12 Log Menu (continued)

| | | | | | | |
|---|--|--|--|--|--|-----------|
| <p>PNU - Log Trip Log Trip Code Descriptions 1001 Short Circuit Thyristor</p> | <p>One or more of the internal control thyristors (SCRs) have failed short circuit.</p> <p>The Unit has detected that the SCRs are not operating as expected.</p> <p>ISOLATE SUPPLY + MOTOR Disconnect supply. Check by measuring the resistance between L1-T1 L2-T2 L3-T3 (Anything < 10R is assumed short circuit).</p> | | | | | Read Only |
| <p>PNU - Log Trip Log Trip Code Descriptions 1101 Low Current Trip</p> | <p>The motor current has been lower than the low trip level for the low trip time.</p> <p>This trip is not active during soft start and soft stop and is "off" by default.</p> <p>If the low current trip is not required turn "off" in "Trip Settings".</p> | | | | | Read Only |
| <p>PNU - Log Trip Log Trip Code Descriptions 1201 Current Limit Timeout Trip</p> | <p>The motor has been held in current limit longer than the "Start current limit Time".</p> <p>It is likely that the current limit level has been set too low for the application.</p> <p>Increase the current limit level or timeout period.</p> | | | | | Read Only |
| <p>PNU - Log Trip Log Trip Code Descriptions 1202 Current Limit Timeout Trip</p> | <p>The motor has been held in current limit longer than the "Stop current limit Time".</p> <p>It is likely that the current limit level has been set too low for the application.</p> <p>Increase the current limit level or timeout period.</p> | | | | | Read Only |
| <p>PNU - Log Trip Log Trip Code Descriptions 1301 Overload Trip</p> | <p>The "Overload" has exceeded 100%.</p> <p>The Unit is attempting to start an application that is outside its capacity or it is starting too often.</p> <p>Refer to the overload trip curves to determine whether the Unit has been sized correctly.</p> | | | | | Read Only |

Operation

5.12 Log Menu (continued)

| Menu | Description | Min | Max | Default | Unit | Reg. Type |
|--|---|-----|-----|---------|------|-----------|
| <p>PNU - Log Trip Log Trip Code Descriptions 1302 Overload Trip</p> | <p>The motor current has exceeded 475% (i-Unit) for a time greater than 250ms.</p> <p>The Unit is attempting to start an application that is outside its capacity with a "high current limit level" set.</p> <p>Refer to the overload trip curves to determine whether the Unit has been sized correctly and check current limit level.</p> | | | | | Read Only |
| <p>PNU - Log Trip Log Trip Code Descriptions 1401 Shearpin Trip</p> | <p>The motor current has been higher than the "Shearpin Trip Level" for the trip time.</p> <p>This trip is not active during soft start and soft stop and is "off" by default.</p> <p>If Shearpin trip is not required turn "off" in "Trip Settings".</p> | | | | | Read Only |
| <p>PNU - Log Trip Log Trip Code Descriptions 1501 PTC Thermistor Trip</p> | <p>The PTC thermistor value has exceeded the trip level.</p> <p>The PTC thermistor connected to the PTC input has exceeded its response temperature or the PTC input is open circuit.</p> <p>If the PTC TRIP is not required turn "off" in "Trip Settings".</p> | | | | | Read Only |
| <p>PNU - Log Trip Log Trip Code Descriptions 1601 External Trip</p> | <p>External Trip.</p> <p>The input programmed to External Trip is active.</p> <p>If the External trip is not required turn "off" in "Trip settings".</p> | | | | | Read Only |
| <p>PNU - Log Trip Log Trip Code Descriptions 1701 Communications Trip</p> | <p>Modbus RTU Communications failure</p> <p>The command or status PNU has not been polled in the time set in the "Timeout" period.</p> <p>If the communication trip is disabled, the Unit cannot be stopped in the communications fail.</p> | | | | | Read Only |

Operation

5.12 Log Menu (continued)

| Menu | Description | Min | Max | Default | Unit | Reg. Type |
|---|---|-----|-----|---------|------|-----------|
| <p>PNU - Log Trip Log Trip Code Descriptions 1702 Communications Trip</p> | <p>Modbus TCP Communications failure</p> <p>The command or status PNU has not been polled in the time set in the "Timeout" period.</p> <p>If the communication trip is disabled, the Unit cannot be stopped in the communications fail.</p> | | | | | Read Only |
| <p>PNU - Log Trip Log Trip Code Descriptions 1703 Communications Trip</p> | <p>Anybus Communications failure</p> <p>The command or status PNU has not been polled in the time set in the "Timeout" period.</p> <p>If the communication trip is disabled, the Unit cannot be stopped in the communications fail.</p> | | | | | Read Only |
| <p>PNU - Log Trip Log Trip Code Descriptions 1704 Communications Trip</p> | <p>Keypad Communications failure</p> <p>The communications bus has failed or become inactive between the keypad and the main unit.</p> <p>If the communication trip is disabled, the Unit cannot be stopped in the communications fail.</p> | | | | | Read Only |
| <p>PNU - Log Trip Log Trip Code Descriptions 1801-1802 Bypass Relay Trip</p> | <p>One or more of the internal bypass relays has failed to close.</p> <p>The internal bypass relay has failed, or the control supply is too weak.</p> <p>Ensure 24Vdc supply meets the requirements specified in the Quick Start Guide.</p> | | | | | Read Only |
| <p>PNU - Log Trip Log Trip Code Descriptions 1803 Bypass Relay Trip</p> | <p>One or more of the internal bypass relays has failed to open.</p> <p>The internal bypass relay has failed, or the control supply is too weak.</p> <p>Ensure 24Vdc supply meets the requirements specified in the Quick Start Guide.</p> | | | | | Read Only |

Operation

5.12 Log Menu (continued)

| Menu | Description | Min | Max | Default | Unit | Reg. Type |
|--|--|-----|-----|---------|------|-----------|
| PNU - Log Trip Log Trip Code Descriptions 2001-2003 Remote Start is Enabled | <p>The remote start signal is active.</p> <p>The remote start signal was active during power up or Reset or Parameter Load.</p> <p>Turn off remote or if Remote On trip is not required turn "off" in "Trip Settings".</p> | | | | | Read Only |
| PNU - Log Trip Log Trip Code Descriptions 2101 Rotation L1 L2 L3 Trip | <p>The input phase rotation is RYB (L1-L2-L3).</p> <p>The phase rotation is opposite to that required.</p> <p>Change phase rotation or if "RYB" trip is not required turn "off" in trip settings.</p> | | | | | Read Only |
| PNU - Log Trip Log Trip Code Descriptions 2102 Rotation L1 L3 L2 Trip | <p>The input phase rotation is RBY (L1-L3-L2).</p> <p>The phase rotation is opposite to that required.</p> <p>Change phase rotation or if "RBY" trip is not required turn "off" in trip settings.</p> | | | | | Read Only |
| PNU - Log Trip Log Trip Code Descriptions 2201-2299 MPU Trip | <p>Internal Unit Failure.</p> <p>The Unit has failed internally and is unable to recover automatically.</p> <p>Cycle the control supply.</p> <p>If the fault is not cleared, then contact the supplier.</p> | | | | | Read Only |
| PNU - Log Trip Log Trip Code Descriptions 2301-2303 Current Sensor Trip | <p>Current sensor failure.</p> <p>One or more of the internal sensors used to measure current has failed or is reading a low value.</p> <p>Check the connections to the supply and motor as disconnection will result in a zero current reading.</p> <p>Check the plate FLA of the motor being controlled is at least 25% of the "i-motor" rating.</p> | | | | | Read Only |

Operation

5.12 Log Menu (continued)

| Menu | Description | Min | Max | Default | Unit | Reg. Type |
|--|---|-----|-------|---------|------|-----------|
| <p>PNU - Log Trip Log Trip Code Descriptions 2401-2499 Operation 2 Trip</p> | <p>Fail Safe operation (Operation 2)</p> <p>A process associated with the Main micro controller has been affected and is unable to recover automatically</p> <p>The trip MUST be reset by either the digital input or keypad or the bus command depending on the control method set.</p> <p>This trip is a special case and it is NOT possible to reset this trip by cycling the control supply</p> | | | | | Read Only |
| <p>PNU - Log Trip Log Trip Code Descriptions 2601-2699 Operation 1 Trip</p> | <p>Fail Safe operation (Operation 1)</p> <p>A process associated with the Logging function has been affected and is unable to recover automatically</p> <p>The trip can be reset by either the digital input or keypad or the bus command depending on the control method set.</p> <p>It is also possible to reset this trip by cycling the control supply</p> | | | | | Read Only |
| <p>PNU - Log Trip Log Trip Code Descriptions 2701-2799 MPU Trip</p> | <p>Internal Unit Failure (MPU / Operation 5)</p> <p>The Unit has failed internally and is unable to recover automatically.</p> <p>Cycle the control supply.</p> <p>If the fault is not cleared then contact the supplier</p> | | | | | Read Only |
| <p>PNU 38400 Log Trip Log ↓ Last Peak Current</p> | <p>Displays the peak current of the last successful start.</p> | 0 | 10000 | 0 | A | Read Only |





Operation

5.12 Log Menu (continued)

| Menu | Description | Min | Max | Default | Unit | Reg. Type |
|---|--|-----|-------|---------|------|-----------|
| PNU 38402 Log Trip Log ↓ Last peak start current -1 | Displays the peak current of the last successful start -1. | 0 | 10000 | 0 | A | Read Only |
| PNU 38404 Log Trip Log ↓ Last peak start current -2 | Displays the peak current of the last successful start -2. | 0 | 10000 | 0 | A | Read Only |
| PNU 38406 Log Trip Log ↓ Last peak start current -3 | Displays the peak current of the last successful start -3. | 0 | 10000 | 0 | A | Read Only |
| PNU 38408 Log Trip Log ↓ Last peak start current -4 | Displays the peak current of the last successful start -4. | 0 | 10000 | 0 | A | Read Only |
| PNU 38410 Log Trip Log ↓ Last peak start current -5 | Displays the peak current of the last successful start -5. | 0 | 10000 | 0 | A | Read Only |

Operation

5.12 Log Menu (continued)

| Menu | Description | Min | Max | Default | Unit | Reg. Type |
|---|--|-----|-------|---------|------|-----------|
| PNU 38412 Log Trip Log  Last peak start current -6 | Displays the peak current of the last successful start -6. | 0 | 10000 | 0 | A | Read Only |
| PNU 38414 Log Trip Log  Last peak start current -7 | Displays the peak current of the last successful start -7. | 0 | 10000 | 0 | A | Read Only |
| PNU 38416 Log Trip Log  Last peak start current -8 | Displays the peak current of the last successful start -8. | 0 | 10000 | 0 | A | Read Only |
| PNU 38418 Log Trip Log  Last peak start current -9 | Displays the peak current of the last successful start -9. | 0 | 10000 | 0 | A | Read Only |
| PNU 39040 Log Trip Log  Last peak stop current | Displays the peak current of the last successful stop. | 0 | 10000 | 0 | A | Read Only |





Operation

5.12 Log Menu (continued)

| Menu | Description | Min | Max | Default | Unit | Reg. Type |
|--|---|-----|-------|---------|------|-----------|
| PNU 39042 Log Trip Log ↓ Last peak stop current -1 | Displays the peak current of the last successful stop -1. | 0 | 10000 | 0 | A | Read Only |
| PNU 39044 Log Trip Log ↓ Last peak stop current -2 | Displays the peak current of the last successful stop -2. | 0 | 10000 | 0 | A | Read Only |
| PNU 39046 Log Trip Log ↓ Last peak stop current -3 | Displays the peak current of the last successful stop -3. | 0 | 10000 | 0 | A | Read Only |
| PNU 39048 Log Trip Log ↓ Last peak stop current -4 | Displays the peak current of the last successful stop -4. | 0 | 10000 | 0 | A | Read Only |
| PNU 39050 Log Trip Log ↓ Last peak stop current -5 | Displays the peak current of the last successful stop -5. | 0 | 10000 | 0 | A | Read Only |







Operation

5.12 Log Menu (continued)

| Menu | Description | Min | Max | Default | Unit | Reg. Type |
|--|--|-----|-------|---------|------|-----------|
| PNU 39052 Log Trip Log  Last peak stop current -6 | Displays the peak current of the last successful stop -6. | 0 | 10000 | 0 | A | Read Only |
| PNU 39054 Log Trip Log  Last peak stop current -7 | Displays the peak current of the last successful stop -7. | 0 | 10000 | 0 | A | Read Only |
| PNU 39056 Log Trip Log  Last peak stop current -8 | Displays the peak current of the last successful stop -8. | 0 | 10000 | 0 | A | Read Only |
| PNU 39058 Log Trip Log  Last peak stop current -9 | Displays the peak current of the last successful stop -9. | 0 | 10000 | 0 | A | Read Only |
| PNU 39680 Log Trip Log  Last temperature | Displays the heatsink temperature at the end of the last successful start. | -20 | 80 | | °C | Read Only |







Operation

5.12 Log Menu (continued)

| Menu | Description | Min | Max | Default | Unit | Reg. Type |
|--|---|-----|-----|---------|------|-----------|
| PNU 39681 Log Trip Log  Last temperature -1 | Displays the heatsink temperature at the end of the last successful start -1. | -20 | 80 | | °C | Read Only |
| PNU 39682 Log Trip Log  Last temperature -2 | Displays the heatsink temperature at the end of the last successful start -2. | -20 | 80 | | °C | Read Only |
| PNU 39683 Log Trip Log  Last temperature -3 | Displays the heatsink temperature at the end of the last successful start-3. | -20 | 80 | | °C | Read Only |
| PNU 39684 Log Trip Log  Last temperature -4 | Displays the heatsink temperature at the end of the last successful start-4. | -20 | 80 | | °C | Read Only |
| PNU 39685 Log Trip Log  Last temperature -5 | Displays the heatsink temperature at the end of the last successful start-5. | -20 | 80 | | °C | Read Only |
| PNU 39686 Log Trip Log  Last temperature -6 | Displays the heatsink temperature at the end of the last successful start-6. | -20 | 80 | | °C | Read Only |

Operation

5.12 Log Menu (continued)

| Menu | Description | Min | Max | Default | Unit | Reg. Type |
|--|--|-----|-----|---------|------|-----------|
| PNU 39687 Log Trip Log  Last temperature -7 | Displays the heatsink temperature at the end of the last successful start-7. | -20 | 80 | | °C | Read Only |
| PNU 39688 Log Trip Log  Last temperature -8 | Displays the heatsink temperature at the end of the last successful start-8. | -20 | 80 | | °C | Read Only |
| PNU 39689 Log Trip Log  Last temperature -9 | Displays the heatsink temperature at the end of the last successful start-9. | -20 | 80 | | °C | Read Only |
| PNU 40320 Log Trip Log  Last overload | Displays the overload level at the end of the last successful start. | 0 | 100 | 0 | % | Read Only |
| PNU 40321 Log Trip Log  Last overload-1 | Displays the overload level at the end of the last successful start -1. | 0 | 100 | 0 | % | Read Only |
| PNU 40322 Log Trip Log  Last overload-2 | Displays the overload level at the end of the last successful start -2. | 0 | 100 | 0 | % | Read Only |









Operation

5.12 Log Menu (continued)

| Menu | Description | Min | Max | Default | Unit | Reg. Type |
|--|---|-----|-----|---------|------|-----------|
| PNU 40323 Log Trip Log ↓ Last overload-3 | Displays the overload level at the end of the last successful start -3. | 0 | 100 | 0 | % | Read Only |
| PNU 40324 Log Trip Log ↓ Last overload-4 | Displays the overload level at the end of the last successful start -4. | 0 | 100 | 0 | % | Read Only |
| PNU 40325 Log Trip Log ↓ Last overload-5 | Displays the overload level at the end of the last successful start -5. | 0 | 100 | 0 | % | Read Only |
| PNU 40326 Log Trip Log ↓ Last overload-6 | Displays the overload level at the end of the last successful start -6. | 0 | 100 | 0 | % | Read Only |
| PNU 40327 Log Trip Log ↓ Last overload-7 | Displays the overload level at the end of the last successful start -7. | 0 | 100 | 0 | % | Read Only |
| PNU 40328 Log Trip Log ↓ Last overload-8 | Displays the overload level at the end of the last successful start -8. | 0 | 100 | 0 | % | Read Only |













Operation

5.12 Log Menu (continued)

| Menu | Description | Min | Max | Default | Unit | Reg. Type |
|---|--|-----|------------|---------|------|------------|
| PNU 40329 Log Trip Log  Last overload-9 | Displays the overload level at the end of the last successful start -9. | 0 | 100 | 0 | % | Read Only |
| PNU 35840 Log Totals Log  Number of Starts | The total number of successful starts. | 0 | 4294836225 | 0 | | Read Only |
| PNU 35904 Log Totals Log  Motor Running Time | The total time the motor has been running. | 0 | 4294836225 | 0 | s | Read Only |
| PNU 35906 Log Totals Log  Control Supply On Time | The total time the Unit has been powered up. | 0 | 4294836225 | 0 | s | Read Only |
| PNU - Log   Download Log File | Download the full log file on to the USB stick. The Unit logs several parameters during normal and fault conditions. Data is stored in CSV format. Please send all downloaded files on request | | | | | Read/Write |
| PNU 62081 Log   Clear Trip Log | Deletes all of the history in the Trip Log. | No | Yes | No | | Read/Write |

Operation

5.13 Device Menu

| Menu | Description | Min | Max | Default | Unit | Reg. Type |
|---|---|----------|-------------|----------|----------|------------|
| PNU - Device   Update Firmware | <p>Used to upgrade to the latest version of software using a USB stick</p> <p>Details for the upgrading process are supplied with the updated version of software</p> | | | | | Read/Write |
| PNU - Device   Date | <p>Enter current date.</p> <p>Date format can be set to either dd/mm/yyyy or mm/dd/yyyy. Refer to "Date format" parameter.</p> | | | | | Read/Write |
| PNU 14720 Device   Time | <p>Allows the time to be changed to 'local' time.</p> <p>By default, the time is set to GMT.</p> | hh:mm:ss | hh:mm:ss | GMT time | hh:mm:ss | Read/Write |
| PNU - Device   Language | <p>Selects the display language for the keypad</p> <p>Enter the required language from the displayed list</p> | 0 | End of List | 0 | | Read/Write |
| PNU - Device   Passcode | <p>Stops unauthorised access to read/ write parameters.</p> <p>For the passcode be active the "Screen lock" must be turned on.</p> | 0 | Max Value | 0 | | Read/Write |
| PNU - Device   Backlight Timeout | <p>Time for backlight on display</p> <p>After the period set the back light on the screen will turn off</p> <p>To reactivate touch screen anywhere. To disable set to 0</p> | 0 | 3600 | 60 | s | Read/Write |









Operation

5.13 Device Menu (continued)

| Menu | Description | Min | Max | Default | Unit | Reg. Type |
|--|---|------|--------|---------|------|------------|
| PNU 16000 Device Networks Modbus Network Settings Address | Sets the Modbus station number | 1 | 32 | 1 | | Read/Write |
| PNU 16064 Device Networks Modbus Network Settings Baud Rate | Sets the serial communications baud rate. The available baud rates are 9600 19200 38400 57600 or 115200. | 9600 | 115200 | 19200 | | Read/Write |
| PNU 16128 Device Networks Modbus Network Settings Parity | Sets the serial communications parity bit. The available parity options are None Even Odd. Also sets the stop bits. No parity uses 2 stop bits. Odd or even parity uses 1 stop bit. | None | Odd | Even | | Read/Write |
| PNU 14080 Device Networks Modbus Network Settings Traffic LEDS | Allows the user to check the state of the modbus communication network. Red LED receive. Green LED Transmit. On: The Red and Green LEDS display the traffic on the Modbus communications network. Off: The Red and Green LEDs display the Unit status information. | Off | On | Off | | Read/Write |
| PNU - Device Networks  Anybus | Anybus expansion module. Only active with Anybus module fitted. | | | | | Read Only |

Operation

5.13 Device Menu (continued)

| Menu | Description | Min | Max | Default | Unit | Reg. Type |
|--|--|-----|-------|---------|------|------------|
| PNU 15808 Device Networks  Timeout ms | <p>Communications trip Timeout period.</p> <p>To prevent a 'Communications Trip' (If enabled) the bus must be kept active.</p> <p>To keep the bus active there must be at least one Modbus read or write (any PNU) during the "Timeout ms" period.</p> | 0 | 60000 | 5000 | ms | Read/Write |
| PNU 53802 Device Networks  Communications Shutdown | <p>This works in conjunction with the 'Communications Trip'.</p> <p>On: If the 'Communication Trip' is turned 'On' the unit will shut down instead of tripping if the communications fail.</p> <p>Off: If the 'Communication Trip' is turned 'On' the unit will trip if the communications fail.</p> | Off | On | Off | | Read/Write |
| PNU 62080 Device   Reset Defaults | Restores the Unit to the factory defaults. | No | Yes | No | | Read/Write |
| PNU - Device   About | <p>Gives the Model number. Serial Number and current software versions.</p> <p>The software versions are SGY1xxxxxx SGY2xxxxxx and SGY3xxxxxx.</p> | | | | | Read Only |
| PNU - Device   Screen Lock | Stops unauthorised access to read/ write parameters. | Off | On | Off | | Read/Write |

Operation

5.13 Device Menu (continued)

| Menu | Description | Min | Max | Default | Unit | Reg. Type |
|---|--|------------|------------|------------|------|------------|
| PNU - Device ↓ ↓ Date Format | Allows the date format to be changed dd/mm/yyyy or mm/dd/yyyy. | dd/mm/yyyy | mm/dd/yyyy | dd/mm/yyyy | | Read/Write |
| PNU - Device ↓ ↓ Temperature Format | Selects °C or °F for displayed temperatures. °C: All displayed temperatures are °C. °F: All displayed temperatures are °F. | °C | °F | °C | | Read/Write |
| PNU - Device ↓ ↓ Parameters to USB | Allows the user to save parameters. Downloads the parameters from the Unit to the USB drive. Data is stored in CSV format. | No | Yes | No | | Read/Write |
| PNU - Device ↓ ↓ Parameters from USB | Allows the user to load parameters stored on a USB flash drive. Uploads the parameters from the USB drive to the Unit. Data is stored in CSV format. | No | Yes | No | | Read/Write |
| PNU - 53765 Device ↓ ↓ Keypad Trip | Detects if the communications bus has failed or become inactive between the keypad and the main unit. On :Keypad trip enabled. Off : Keypad trip disabled. | Off | On | On | | Read/Write |

Operation

5.13 Device Menu (continued)

| Menu | Description | Min | Max | Default | Unit | Reg. Type |
|--|---|-----|-------|---------|------|------------|
| PNU 15809 Device ↓ ↓ Timeout ms | Keypad Communications trip Timeout period When enabled the unit will trip if there is a loss of communication greater than the "Timeout ms" period | 0 | 60000 | 50000 | ms | Read/Write |
| PNU 13120 Device ↓ ↓ Service Code | Diagnostic parameter. For Internal use only. | | | | | |

Operation

5.14 Functional Summaries

5.14.1 Automatic Settings

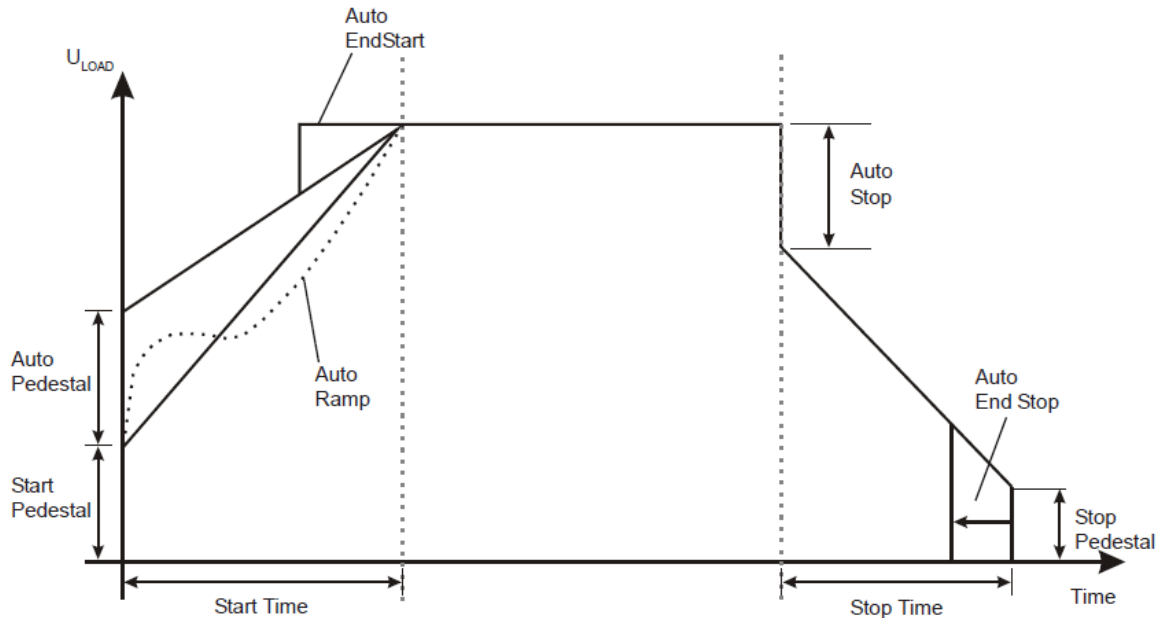

Automatic Pedestal - Automatic overriding of the start pedestal. When On the unit approximately detects the start of motor rotation and tries to adjust the pedestal to suit..

Automatic End Start - Automatic detection of motor full speed during the start-up. Having detected motor full speed achieved before the end of the programmed ramp, this menu item brings forward the end of the ramp cutting short an overlong programmed start.

Automatic Ramp - Automatically detects motor acceleration and dynamically adjusts the ramp to give smoother acceleration. This menu item works in conjunction with the Start Time parameter which should be set to the estimated start time of the load. This would be suitable for starts with varying loads.

Automatic Stop - Automatic adjustment of the soft stop. When On the unit attempts to automatically adjust the soft stop profile to suit the load.

Automatic End Stop - Automatic detection of a stalled motor during soft stop. When On and the motor has stopped before the end of the unit's programmed soft stop the unit will attempt to detect the stall and turn off the thyristors thus truncating the soft stop time.

Auto End Stop - Automatic detection of a stalled motor during soft stop. When On and the motor has stopped before the end of the unit's programmed soft stop the unit will attempt to detect the stall and turn off the thyristors thus truncating the soft stop time.

Operation

5.14 Functional Summaries (continued)

5.14.2 Low Current Protection

A Low Current trip occurs when the current output measured by the unit falls below the level specified by the Low amps level parameter for a length of time specified by the Low Amps Time parameter

1. I_{LOW} = Low Amps Level.
2. If I_{LOAD} drops below 'Low Amps Level' and 'Low Current' is set to 'on', and 'Low Amps Time' is set to minimum then the unit will trip as indicated by the short thick dotted line.
3. If 'Low Amps Time' is set to maximum and I_{LOAD} rises above 'Low Amps Level' before 'Low Amps Time' has elapsed then the unit will not trip.

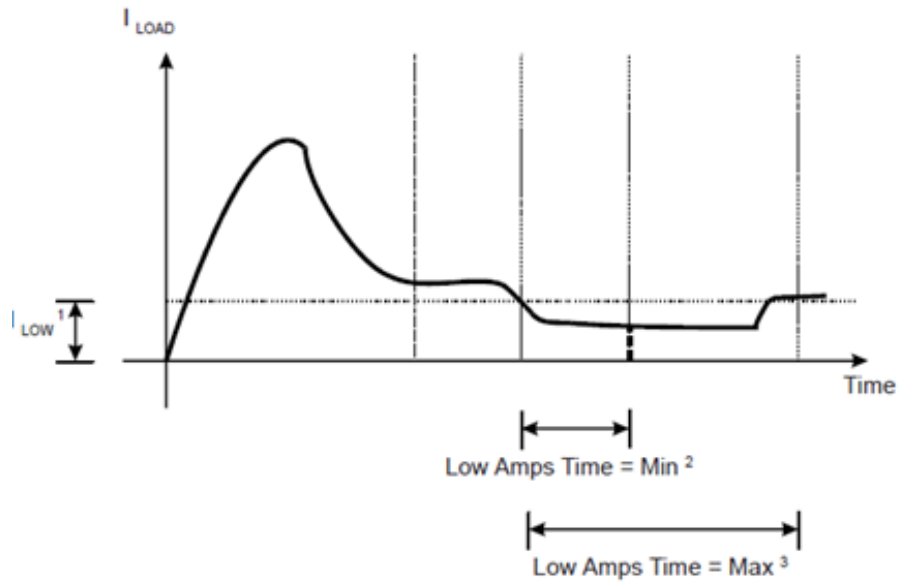

5.14.3 Current Limit

1. If I_{LOAD} exceeds 'Current Limit Level' for time 'Limit Time Out' and 'C/L Time Out' is on, the unit will trip at the thick dotted line. If 'C/L Time Out' is off the unit will continue ramping until T.O.R. and then enter the Dwell period.
2. If the unit current limits during start-up the start time will be elongated by the amount of time that the unit was current limiting.
3. The actual current rises slightly above the level set in 'Current Limit' because the unit manages the current through control of the thyristor firing delay angle.

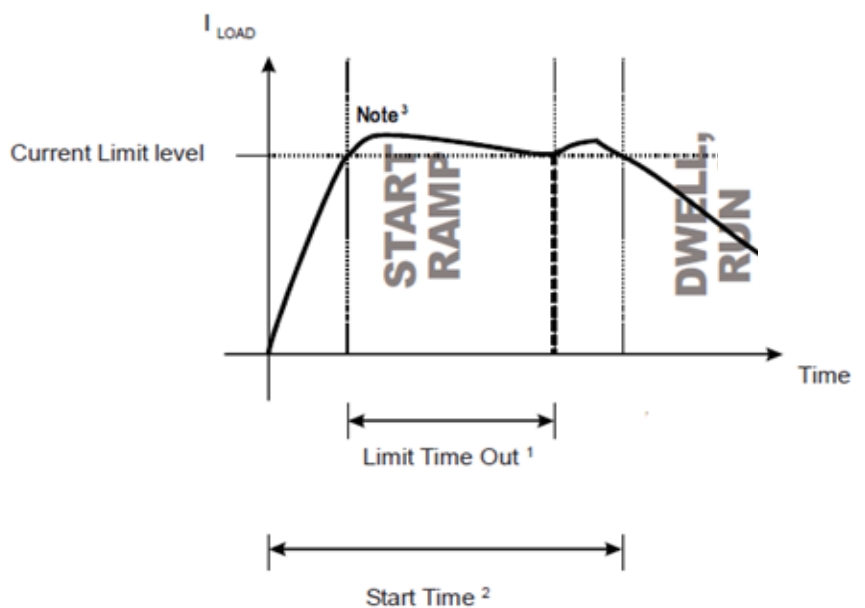

Operation

5.14.4 Shearpin

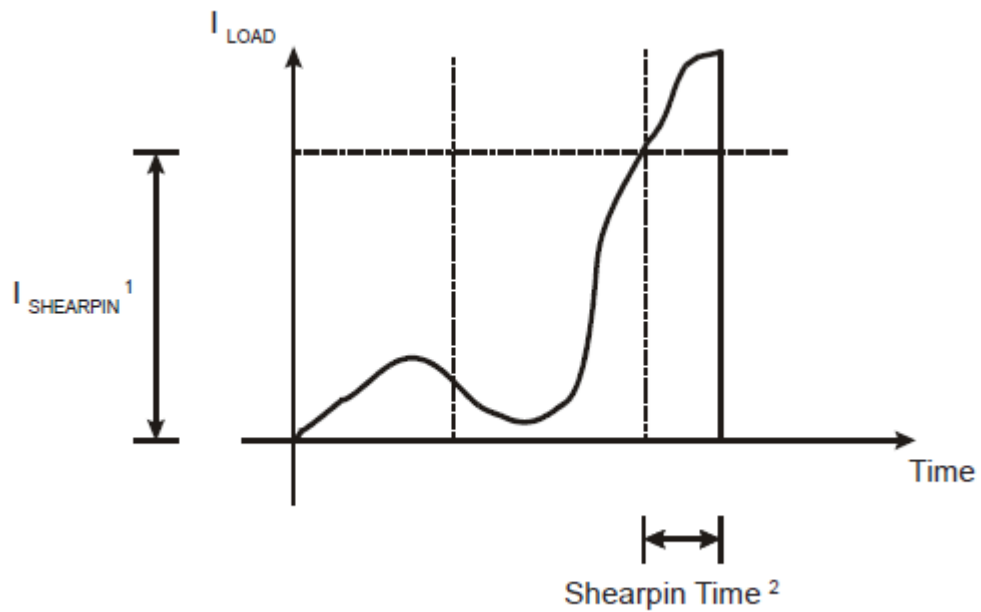

1. $I_{SHEARPIN} =$ Shearpin Level.

2. If I_{LOAD} exceeds $I_{SHEARPIN}$ for a time equal to 'Shearpin Time', and 'Shearpin' is set to 'on', then the unit will trip

Operation

5.15 Touchscreen Menu Paths

5.15.1 Advanced Menu

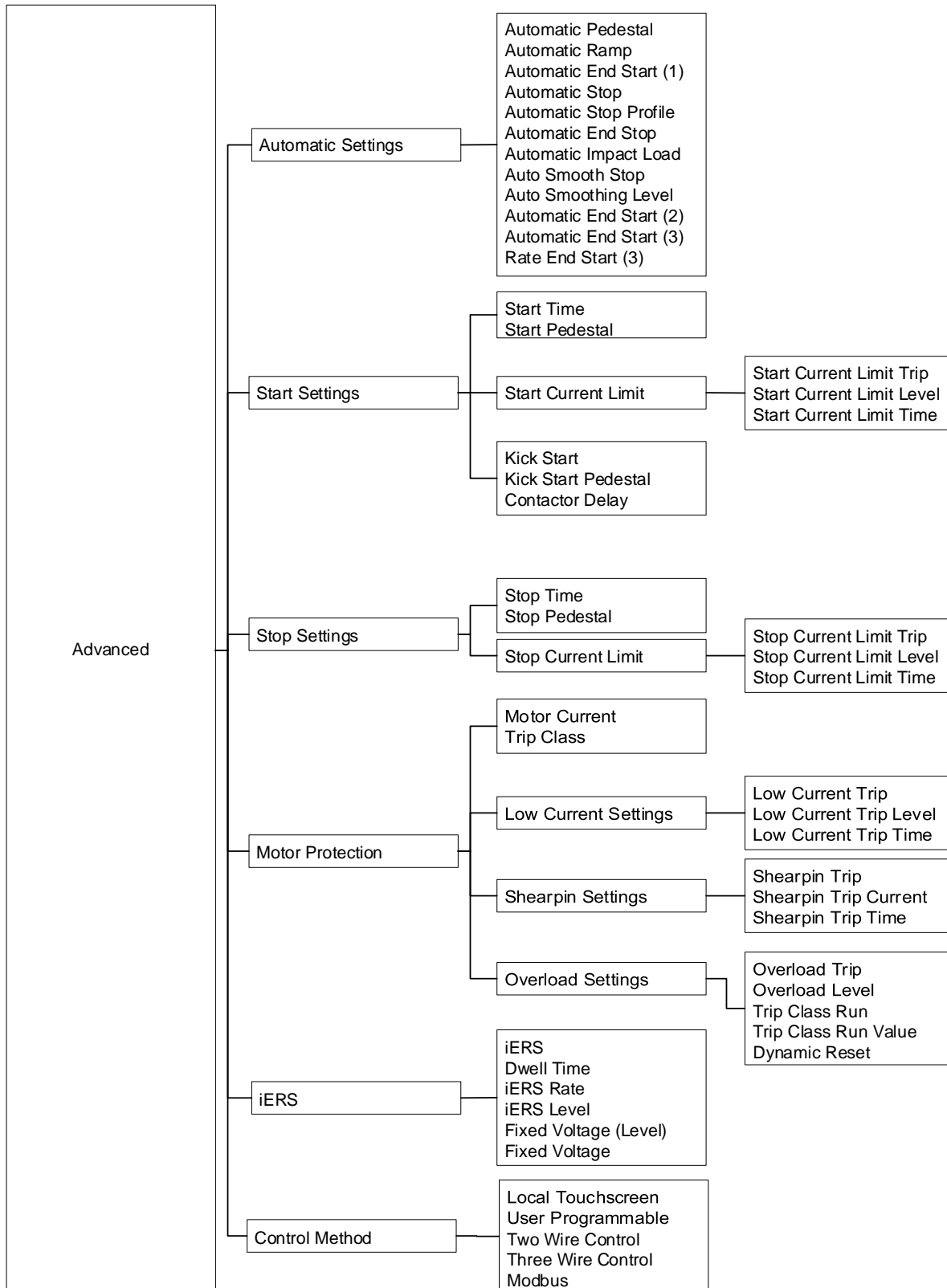

Operation

5.15.1 Advanced (continued)

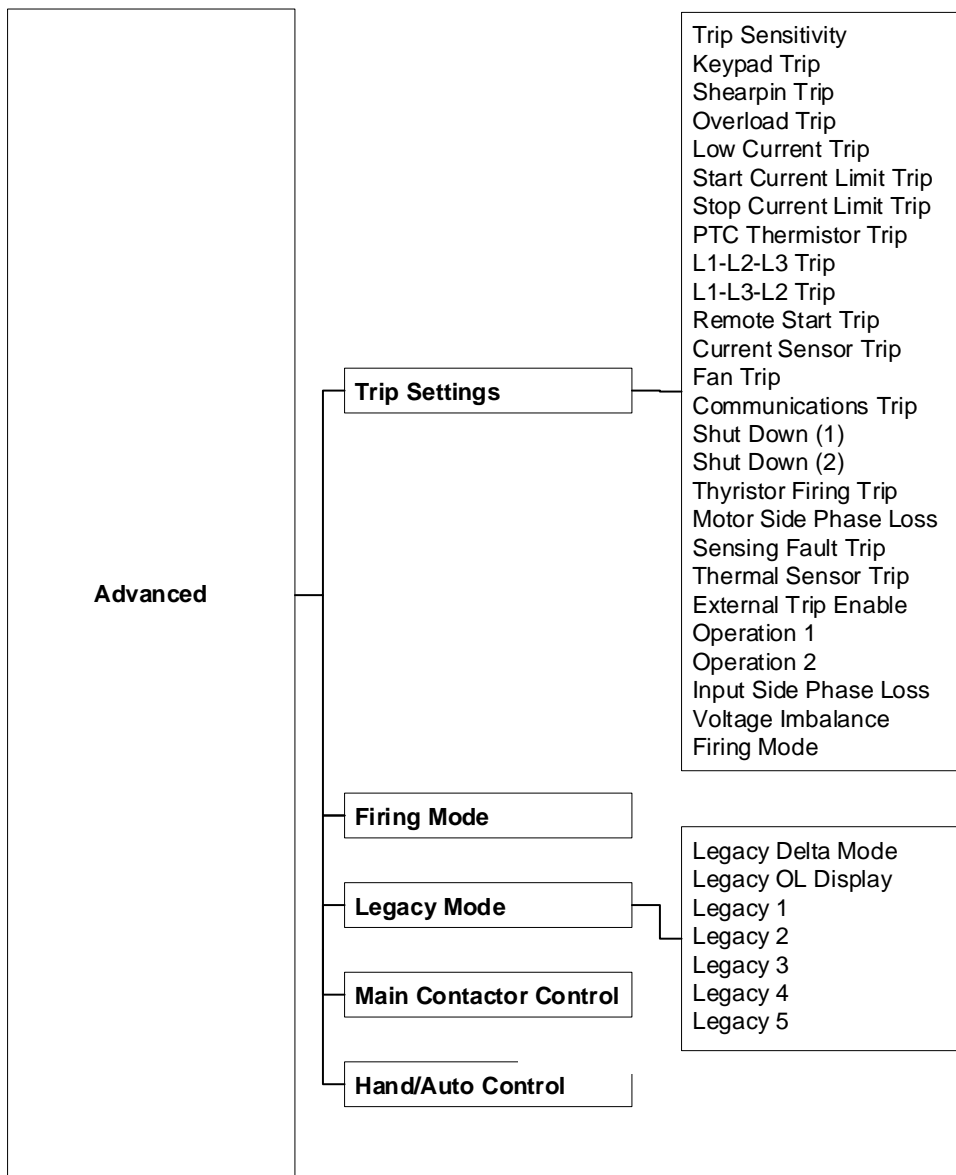

Operation

5.15.1 Advanced (continued)

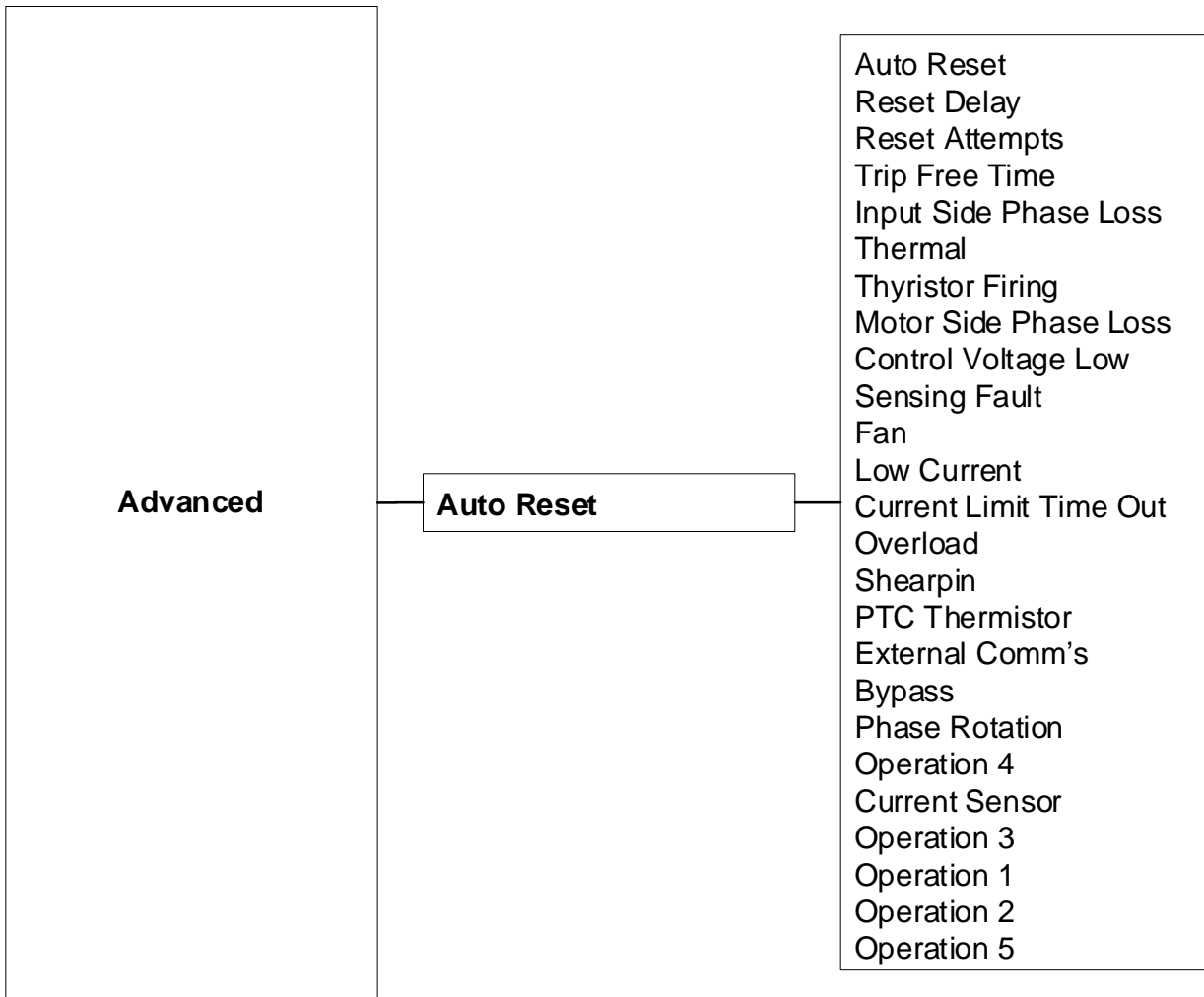

Operation

5.15.2 Input / output Menu

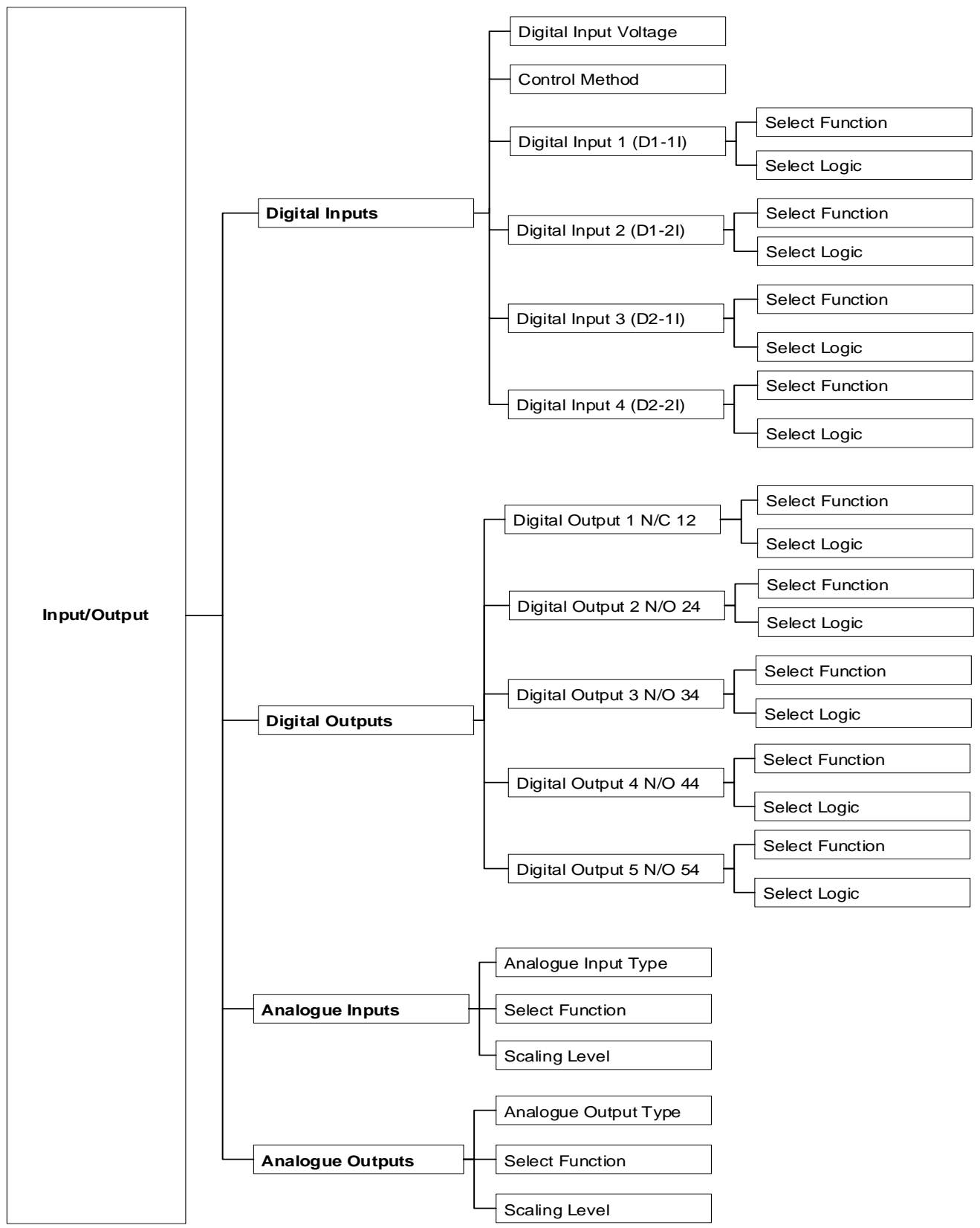

Operation

5.15.3 Monitor

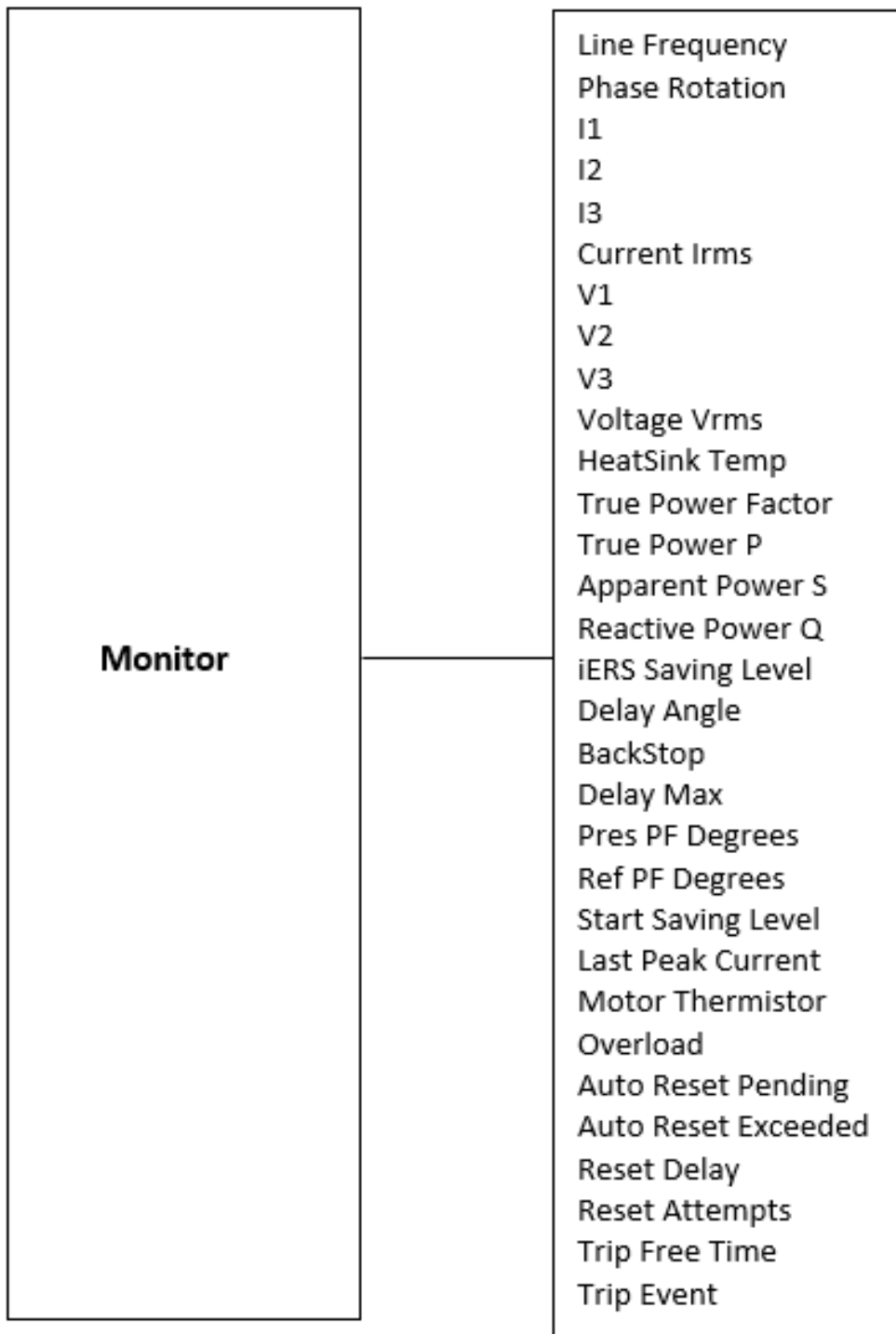

Operation

5.15.4 Log Menu

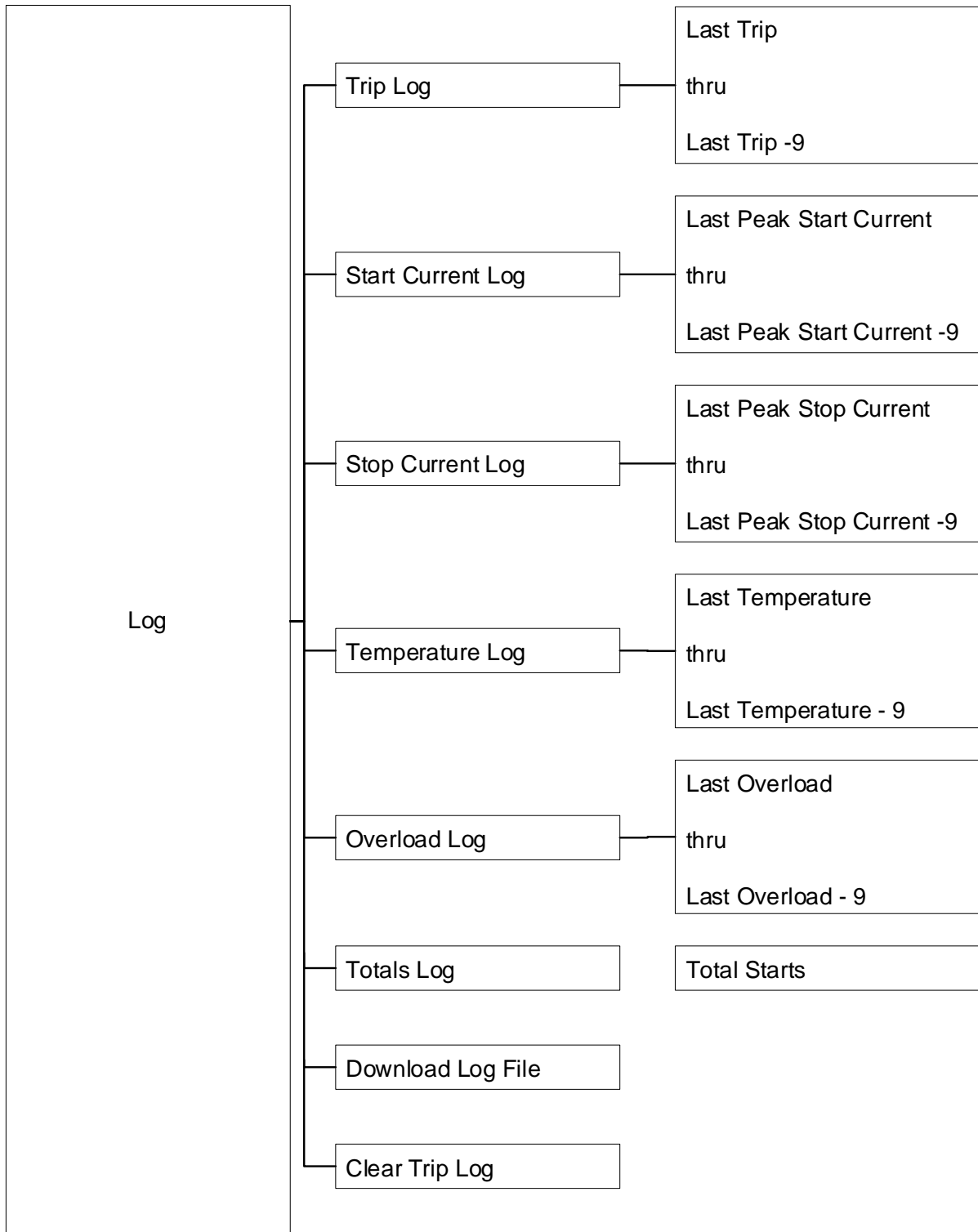

Trip and Fault Codes

6 Trip and Fault Codes

6.1 Trip Code Descriptions

| Number & Name | Description |
|-------------------------------------|---|
| 101 Input Side Phase Loss | <p>Phase L1 missing at the instant of start up.</p> <ul style="list-style-type: none"> • The L1 phase is either missing or at a very low level. • Check all incoming connections. • If a main contactor is being controlled by a digital output set to "Running," check that "Contactor Delay" (under "Start Settings") is sufficient. |
| 102 Input Side Phase Loss | <p>Phase L2 missing at the instant of start up.</p> <ul style="list-style-type: none"> • The L2 phase is either missing or at a very low level. • Check all incoming connections. • If a main contactor is being controlled by a digital output set to "Running," check that "Contactor Delay" (under "Start Settings") is sufficient. |
| 103 Input Side Phase Loss | <p>Phase L3 missing at the instant of start up.</p> <ul style="list-style-type: none"> • The L3 phase is either missing or at a very low level. • Check all incoming connections. • If a main contactor is being controlled by a digital output set to "Running," check that "Contactor Delay" (under "Start Settings") is sufficient. |
| 104 - 117 Input Side Phase Loss | <p>Any or all phases missing when the motor is being controlled (running).</p> <ul style="list-style-type: none"> • L1, L2, or L3 are missing or at a very low level. • Check all incoming connections. • Check any fuses/breakers incorporated in the power circuit. |
| 150 Voltage Imbalance Trip | <p>The three phase input voltages are imbalanced</p> <ul style="list-style-type: none"> • The maximum voltage is determined, and the other voltages are compared to it. • Check all incoming connections • Check any fuses/ breakers incorporated in the power circuit. |
| 201 Maximum Temperature Exceeded | <p>Internal heatsink temperature has exceeded 80°C.</p> <ul style="list-style-type: none"> • It is possible the VMX-Synergy Plus™ is operating outside specified limits. • Check enclosure ventilation and airflow around the VMX-Synergy Plus™ • If the unit trips immediately, the internal temperature sensor could be faulty. |
| 208 Thermal Sensor Trip | <p>Thermal sensor failure.</p> <ul style="list-style-type: none"> • The internal temperature sensor has failed. • Contact your supplier. |
| 301-308 Thyristor Firing Trip | <p>One or more of the internal control thyristors (SCRs) have failed to turn on properly (In-Line "Firing Mode").</p> <ul style="list-style-type: none"> • The VMX-Synergy Plus™ has detected that the SCRs are not operating as expected. • Check all incoming and outgoing connections. |

Trip and Fault Codes

6.1 Trip Code Descriptions (continued)

| Number & Name | Description |
|------------------------------------|---|
| 350-358 Thyristor Firing Trip | <p>One or more of the internal control thyristors (SCRs) have failed to turn on properly (Delta "Firing Mode").</p> <ul style="list-style-type: none"> The VMX-Synergy Plus™ has detected that the SCRs are not operating as expected. <p>Check all incoming and outgoing connections.</p> |
| 401 Motor Side Phase Loss | <p>One or all of the phases are missing on the motor side during the instant of start up.</p> <ul style="list-style-type: none"> T1, T2, or T3 are missing or at a very low level. Check that the motor is connected to T1, T2 and T3. Ensure any disconnecting device between the VMX-Synergy Plus™ and the motor is closed at the instant of start up. |
| 402-403 Motor Side Phase Loss | <p>One or all of the phases are missing on the motor side during the instant of start up when the motor is being controlled.</p> <ul style="list-style-type: none"> T1, T2 or T3 are missing or at a very low level. Check all incoming and outgoing connections. |
| 601 Control Voltage Too Low | <p>The internal control supply of the VMX-Synergy Plus™ level has fallen to a low level.</p> <ul style="list-style-type: none"> Can be caused by a weak 24Vdc/115Vac/230Vac control supply. Ensure 24Vdc/115Vac/230Vac supply meets the requirements specified in "Electrical Installation" Chapter 2 or the Quick Start Guide. |
| 701-710 Sensing Fault Trip | <p>One or more of the internal control thyristors (SCRs) have failed to turn on properly.</p> <ul style="list-style-type: none"> The VMX-Synergy Plus™ has detected that the SCRs are not operating as expected. Check connections all incoming and outgoing connections. |
| 801-802 Fan Problem | <p>One or more of the internal cooling fans has failed.</p> <ul style="list-style-type: none"> To ensure the heatsink is cooled sufficiently, the VMX-Synergy Plus™ will trip if the fans fail to operate. Check VMX-Synergy Plus™ fans for signs of damage or contamination. |
| 1001 Short Circuit Thyristor | <p>One or more of the internal control thyristors (SCRs) have failed short circuit.</p> <ul style="list-style-type: none"> The VMX-Synergy Plus™ has detected that the SCRs are not operating as expected. Check all incoming and outgoing connections. |
| 1101 Low Current Trip | <p>The motor current has been lower than the low trip level for the low trip time.</p> <ul style="list-style-type: none"> This trip is not active during soft start and soft stop and is "off" by default. If the low current trip is not required turn "off" in "Trip Settings". |
| 1201 Current Limit Timeout Trip | <p>The motor has been held in current limit longer than the "Start Current Limit Time."</p> <ul style="list-style-type: none"> It is likely that the current limit level has been set too low for the application. Increase the current limit level or timeout period. |
| 1202 Current Limit Timeout Trip | <p>The motor has been held in current limit longer than the "Stop Current Limit Time."</p> <ul style="list-style-type: none"> It is likely that the current limit level has been set too low for the application. Increase the current limit level or timeout period. |
| 1301 Overload Trip | <p>The "Overload" has exceeded 100%.</p> <ul style="list-style-type: none"> The VMX-Synergy Plus™ is attempting to start an application that is outside its capacity or it is starting too often. Refer to the overload trip curves to determine whether the VMX-Synergy Plus™ has been sized correctly. |

Trip and Fault Codes

6.1 Trip Code Descriptions (continued)

| Number & Name | Description |
|---------------------------------|---|
| 1302 Overload Trip | The motor current has exceeded 475% (i-Synergy Plus) for a time greater than 250ms. <ul style="list-style-type: none"> The VMX-Synergy Plus™ is attempting to start an application that is outside its capacity with a “high current limit level” set. Refer to the overload trip curves to determine whether the VMX-Synergy Plus™ has been sized correctly and check current limit level. |
| 1401 Shearpin Trip | The motor current has been higher than the “Shearpin Trip Level” for the “Shearpin Trip Time.” <ul style="list-style-type: none"> This trip is not active during soft start and soft stop and is “off” by default. If “Shearpin Trip” is not required, turn “off” in “Trip Settings.” |
| 1501 PTC Thermistor Trip | The PTC thermistor value has exceeded the trip level (4kΩ). <ul style="list-style-type: none"> The PTC thermistor connected to the PTC input has exceeded its response temperature, or the PTC input is open circuit. If the PTC Trip is not required, turn “off” in “Trip Settings.” |
| 1601 External Trip | External Trip <ul style="list-style-type: none"> The input programmed to External Trip is active If the External trip is not required turn "off" in "Trip settings" |
| 1701 Communications Trip | Modbus RTU Communications failure. <ul style="list-style-type: none"> The command or status PNU has not been polled in the time set in the "Timeout" period The command or status PNU has not been polled in the time set in the "Timeout" period |
| 1702 Communications Trip | Modbus TCP Communications failure. <ul style="list-style-type: none"> The command or status PNU has not been polled in the time set in the "Timeout" period If the communication trip is disabled, the Unit cannot be stopped if the communications fail |
| 1703 Communications Trip | Anybus Communications failure. <ul style="list-style-type: none"> The command or status PNU has not been polled in the time set in the "Timeout" period If the communication trip is disabled, the Unit cannot be stopped if the communications fail |
| 1704 Communications Trip | Keypad Communications failure. <ul style="list-style-type: none"> The communications bus has failed or become inactive between the keypad and the main unit. If the communication trip is disabled, the Unit cannot be stopped if the communications fail |
| 1801-1802 Bypass Relay Trip | One or more of the internal bypass relays has failed to close. <ul style="list-style-type: none"> The internal bypass relay has failed, or the control supply is too weak. Ensure 24Vdc supply meets the requirements specified in “Electrical Installation” Chapter 2 or the Quick Start Guide. |
| 1803 Bypass Relay Trip | One or more of the internal bypass relays has failed to open. <ul style="list-style-type: none"> The internal bypass relay has failed, or the control supply is too weak. Ensure 24Vdc supply meets the requirements specified in “Electrical Installation” Chapter 2 or the Quick Start Guide. |
| 2001 Remote Start is Enabled | The Remote Start signal is active. <ul style="list-style-type: none"> The “Start/Stop” signal was active during power up or Reset. Turn off “Start/Stop,” or if Remote Start trip is not required, turn “off” in “Trip Settings.” |
| 2101 Rotation L1 L2 L3 Trip | The input phase rotation is RYB (L1, L2, L3). <ul style="list-style-type: none"> The phase rotation is opposite to that required. Change phase rotation, or if “RYB” trip is not required, turn “off” in “Trip Settings.” |

Trip and Fault Codes

6.1 Trip Code Descriptions (continued)

| Number & Name | Description |
|------------------------------------|---|
| 2102 Rotation L1 L3 L2 Trip | <p>The input phase rotation is RBY (L1, L3, L2).</p> <ul style="list-style-type: none"> • The phase rotation is opposite to that required. • Change phase rotation, or if “RBY” trip is not required turn “off” in “Trip Settings.” |
| 2013 Rotation Undetermined Trip | <p>The phase rotation is undetermined.</p> <ul style="list-style-type: none"> • The VMX-Synergy Plus™ is unable to determine whether the input phase rotation is L1, L2, L3 or L1, L3, L2. • Check all incoming and outgoing connections. |
| 2201-2209 MPU Trip | <p>Internal VMX-Synergy Plus™ failure of the main processing unit.</p> <ul style="list-style-type: none"> • The VMX-Synergy Plus™ has failed internally and is unable to recover automatically. • Cycle the control supply • If the fault is not cleared, contact your supplier. |
| 2301-2303 Current Sensor Trip | <p>Current sensor failure</p> <ul style="list-style-type: none"> • One or more of the internal sensors used to measure current has failed or is reading a low value. • Check the connections to the supply and motor as disconnection will result in a zero-current reading. • Check the plate FLA of the motor being controlled is at least 25% of the Motor Current set in the Protection menu |
| 2701-2799 MPU Trip | <p>Internal Unit Failure (MPU / Operation 5)</p> <ul style="list-style-type: none"> • The VMX-Synergy Plus™ has failed internally and is unable to recover automatically. • Cycle the control supply. • If the fault is not cleared, then contact the supplier |

Trip and Fault Codes

6.2 Fail-Safe Codes

6.2.1 Main Board Trip Operation 2 (2402 – 2436)

A trip number in the range of 2402 to 2436 indicates that a process on the main board has been affected in some way and is unable to recover automatically.

- The trip is turned ON and OFF via the “Main Board Trip” (Advanced/Trips)
- The default for this trip is ON
- The trip MUST be reset using either the digital input, touchscreen, or bus command depending on the control method set.
- As this is a special case, it is NOT possible to reset this trip by cycling the control supply.

| Code # | Description |
|--------|--|
| 2402 | Initialization process has been unsuccessful. |
| 2404 | Initialization of the Parameters has been unsuccessful. |
| 2406 | Initialization of the Overload has been unsuccessful. |
| 2408 | Initialization of the Parameter Read has been unsuccessful. |
| 2410 | Initialization of the Overload Read has been unsuccessful. |
| 2412 | Initialization of the Current Measurement has been unsuccessful. |
| 2420 | A main process on the Main Board has been affected and is unable to recover automatically. |
| 2422 | A main process on the Main Board has been affected and is unable to recover automatically. |
| 2424 | A main process on the Main Board has been affected and is unable to recover automatically. |
| 2426 | Communication between the Main Board and Touchscreen Board has been affected and is unable to recover automatically. |
| 2428 | The Modbus communication has been affected and is unable to recover automatically. |
| 2430 | The parameter save has been unsuccessful. |
| 2432 | The logging function has been unsuccessful. |
| 2434 | A main process on the Main Board has been affected and is unable to recover automatically. |
| 2436 | The Anybus communication has been affected and is unable to recover automatically. |

Trip and Fault Codes

6.2.2 Logging Operation 2 Trip (2601 – 2603)

Trip numbers that are in the range of 2601 to 2603 indicate that a process associated with the logging has been affected in some way and has been unable to recover automatically.

- The trip is turned ON and OFF via the “Logging Trip” (Advanced/Trips).
- The default for this trip is OFF.
- With the trip OFF, the logging function will temporarily be disabled if a continual failure is detected.
- When the trip is turned ON, it is reset using either the digital input or keypad or bus command, depending on the control method set.
- It is possible to reset this trip by cycling the control supply.

| Code # | Description |
|--------|---|
| 2601 | The initialization of the event logging function has been unsuccessful for 20 consecutive attempts. |
| 2602 | The event logging function has been unsuccessful for 20 consecutive attempts. |
| 2603 | The SD card could not be accessed after 20 consecutive attempts. |

Communication

7 Communication

7.1 Modbus RTU Serial Communications

All VMX-Synergy Plus™ soft starts support Modbus RTU as standard. The RS-485 serial communications are accessible from the RJ45 connector (see below).

Note: ASCII and RTU transmission modes are defined in the Modbus protocol specification. VMX-Synergy Plus™ uses *only the RTU mode* for the message transmission.

For Modbus RTU parameter tables see MAN-VMX-SGY-MOD

7.1.1 Modbus RTU Connection

Dual RJ45 Socket Location and Pinout

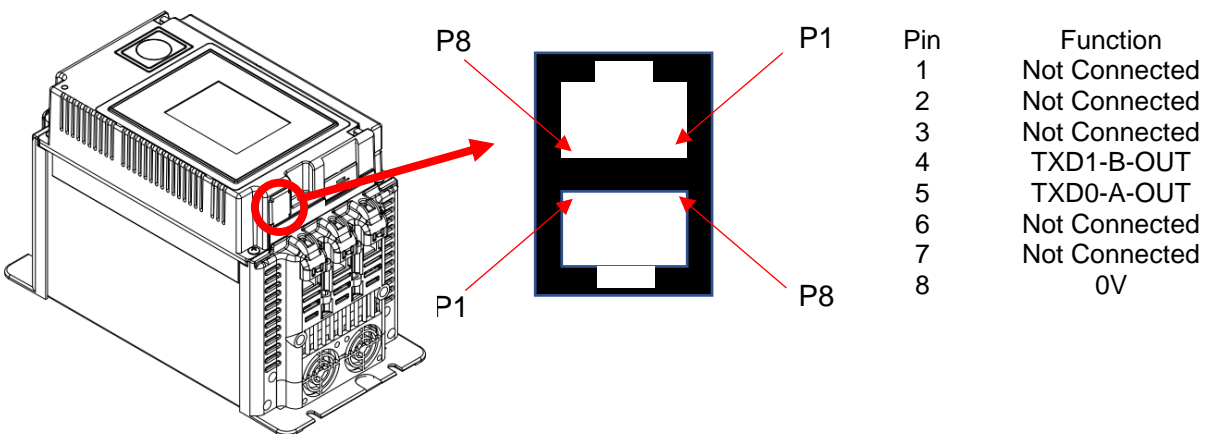

Single VMX-Synergy Plus™ to PLC

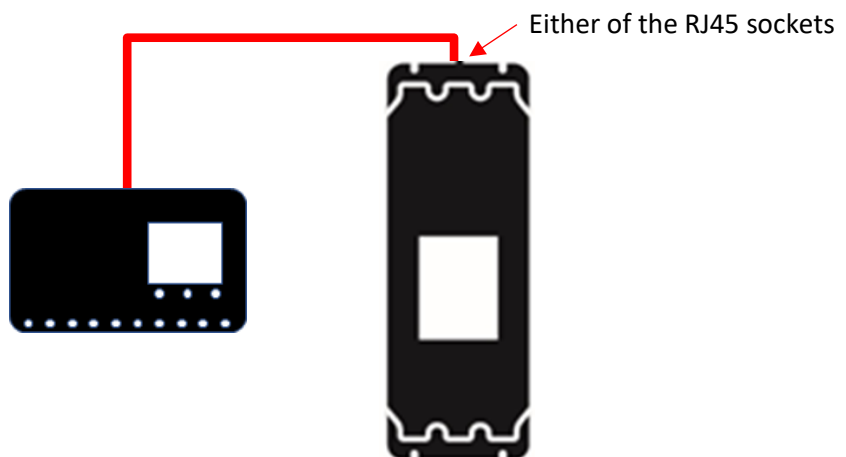

Communication

Multiple VMX-Synergy Plus™ to PLC

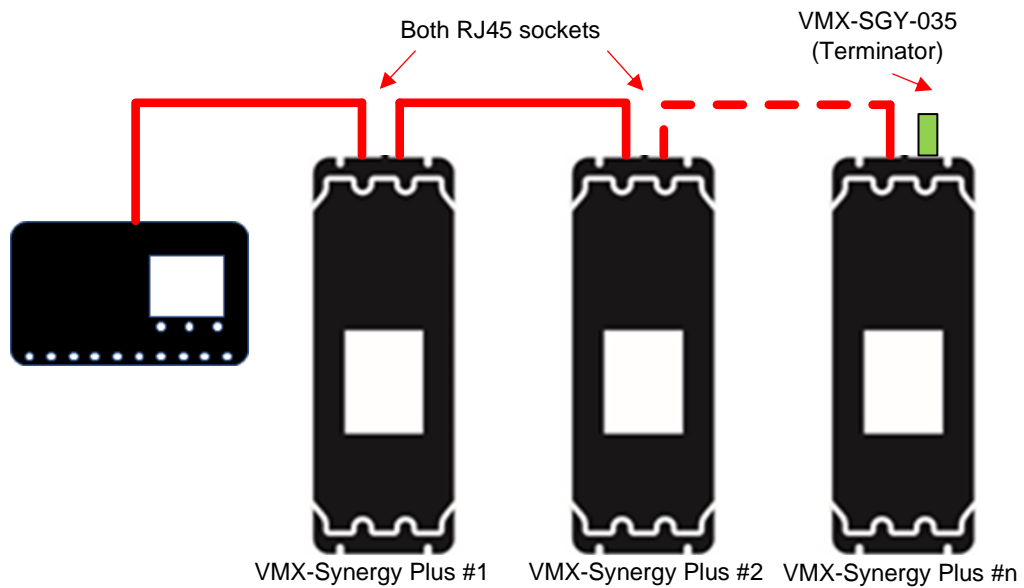

Ensure all units (including the PLC) have the same Baud rate and Parity.
Each VMX-Synergy Plus™ and the PLC must be set to different address numbers (1 to 32)

7.1.2 Modbus Communications Configuration

The Modbus communication settings may be configured from the Device menu:

- Device >> Networks >> Modbus Network Settings >> Address (1 – 32)
- Device >> Networks >> Modbus Network Settings >> Baud (9600 – 115200)
- Device >> Networks >> Modbus Network Settings >> Parity (Odd/Even)
- (Data bits = 8, Stop bits = 1)

The communication parameters should be set before connecting the Modbus master.

Communication

7.1.3 Message Structure for RTU Mode

The Modbus RTU structure uses a master-slave system for message exchange. In the case of the VMX-Synergy Plus™ system, it allows up to 32 slaves, and one master. Every message begins with the master making a request to a slave, which responds to the master in a defined structure. In both messages (request and answer), the used structure is the same: Address, Function Code, Data and CRC.

Master (request message):

| | | | |
|---------------------|----------------------|---------------------------|------------------|
| Address (1 byte) | Function (1 byte) | Request Data (n bytes) | CRC (2 bytes) |
|---------------------|----------------------|---------------------------|------------------|

Slave (response message):

| | | | |
|---------------------|----------------------|----------------------------|------------------|
| Address (1 byte) | Function (1 byte) | Response Data (n bytes) | CRC (2 bytes) |
|---------------------|----------------------|----------------------------|------------------|

Address

The master initiates the communication by sending a byte with the address of the destination slave. When responding, the slave also initiates the message with its own address. Broadcast to address 0 (zero) is not supported.

Function Code

This field contains a single byte, where the master specifies the type of service or function requested to the slave (reading, writing, etc.). According to the protocol, each function is used to access a specific type of data.

Data Field

The format and contents of this field depend on the function used and the transmitted value.

CRC

The used method is the CRC-16 (Cyclic Redundancy Check). This field is formed by two bytes; where first the least significant byte is transmitted (CRC-), and then the most significant (CRC+). The CRC calculation form is described in the Modbus RTU protocol specification.

7.1.4 Supported Functions

Modbus RTU specification defines the functions used to access different types of data. VMX-Synergy Plus™ parameters are defined as holding type registers.

Note that VMX-Synergy Plus™ Modbus addressing starts at zero; not 1 as some devices do.

VMX-Synergy Plus™ 32-bit parameters are High Word/Low Word in Modbus format.

The following services are available:

Communication

Read Holding Registers

Description: reading register blocks of holding register type (block R/W limited to 125 registers).

Function code: 03

| <i>Query</i> | | <i>Response</i> | |
|------------------|-----------------|-----------------|-----------------|
| <i>Field</i> | <i>Hex Byte</i> | <i>Field</i> | <i>Hex Byte</i> |
| Slave address | 01 | Slave | 01 |
| Function | 03 | Function | 03 |
| Start address Hi | 00 | Byte count | 02 |
| Start address Lo | 01 | Data Hi | 01 |
| No of registers | 00 | Data Lo | 2C |
| No of registers | 01 | CRC Lo | B8 |
| CRC Lo | D5 | CRC Hi | 09 |
| CRC Hi | CA | | |

Write Single Register

Description: writing in a single register of the holding type.

Function code: 06

| <i>Query</i> | | <i>Response</i> | |
|---------------|-----------------|-----------------|-----------------|
| <i>Field</i> | <i>Hex Byte</i> | <i>Field</i> | <i>Hex Byte</i> |
| Slave address | 01 | Slave | 01 |
| Function | 06 | Function | 06 |
| Address Hi | 00 | Address Hi | 02 |
| Address Lo | 0C | Address Lo | 0C |
| Data Hi | 00 | Data Hi | 00 |
| Data Lo | 09 | Data Lo | 09 |
| CRC Lo | 48 | CRC Lo | 88 |
| CRC Hi | 0C | CRC Hi | 77 |

Communication

Write Multiple Registers

Description: writing register blocks of holding register type (block R/W limited to 125 registers).

Function code: 16

| <i>Query</i> | | <i>Response</i> | |
|---------------|-----------------|-----------------|-----------------|
| <i>Field</i> | <i>Hex Byte</i> | <i>Field</i> | <i>Hex Byte</i> |
| Slave address | 1 | Slave address | 1 |
| Function | 10 | Function | 10 |
| Address Hi | 00 | Address Hi | 00 |
| Address Lo | 0C | Address Lo | 0C |
| No. Reg Hi | 0 | No. Reg Hi | 0 |
| No. Reg Lo | n | No. Reg Lo | n |
| No. Bytes | n* 2 | Crc Lo | 71 |
| Data 1 Hi | 00 | Crc Hi | A3 |
| Data 1 Low | 0C | | |
| .. | ... | | |
| Data nn Hi | ?? | | |
| Data nn Lo | ?? | | |
| Crc Lo | 48 | | |
| Crc Hi | 0C | | |

(n is the number of holding registers could be any number between 1 and 125)

Memory Map

VMX-Synergy Plus™ Modbus communication is based on reading or writing equipment parameters from or to the holding registers. The data addressing is zero offset, such that the parameter Modbus address corresponds to the register number.

| <i>Parameter Modbus Address</i> | <i>Modbus Data Address</i> | |
|-------------------------------------|----------------------------|--------------------|
| | <i>Decimal</i> | <i>Hexadecimal</i> |
| 0000 | 0 | 0000h |
| 0001 | 1 | 0001h |
| . | . | . |
| . | . | . |
| . | . | . |
| . | . | . |
| 0128 | 128 | 0080h |
| . | . | . |
| . | . | . |
| . | . | . |
| . | . | . |

Communication

Message Timing

In the RTU mode there is no specific start or stop byte that marks the beginning or the end of a message. Indication of when a new message begins or when it ends is achieved by the absence of data transmission for a minimum period of 3.5 times the transmission time of a data byte. Thus, in case a message is transmitted after this minimum time has elapsed; the network elements will assume that the first received character represents the beginning of a new message.

Communication

7.2 Modbus Register Address Aliasing

When addressing the Modbus interface, the positioning/grouping of the existing function registers may make PLC programming difficult in some applications. Grouping of required monitoring, as well as programming, registers may affect the efficiency of the PLC when it requires block fetching and setting of data. With this in mind, the Synergy Plus Modbus address map has a section of user programmable registers, through which up to 16 register aliases can be set. Alongside these there are 16 four byte addresses that correspond with the aliases and act as the data conduits for each select address.

| Alias Register Addresses | 16 bit Alias Registers | Data Address | 32 bit values (2 Word) |
|--------------------------|------------------------|--------------|--------------------------|
| 17600 | e.g. 32000 (base 10) | 17664 | 0x12345678 (HEX) |
| 17601 | | 17666 | |
| 17602 | | 17668 | |
| .. | | ... | |
| .. | | ... | |
| .. | | ... | |
| 17615 | | 17696 | |

The table shows the relationship between the Alias Registers and the Data Registers. The data can take any data type that can fit into 4 bytes. So any address that yields 6 bytes data, such as time, will be incomplete. The access of 1 and 2 byte datum will have redundant bytes in the frame used. Below is an example of what will happen with different sizes.

| Alias Address Addresses | Alias Addresses base10 | Name | Data addresses | Data Shown in 4 Bytes. Greyed have no meaning or affect. | | | |
|-------------------------|------------------------|--------------------|----------------|--|------|------|------|
| 17600 | 26880 | Start I Limit | 17664 | 0x00 | 0x00 | 0xe8 | 0x6c |
| 17601 | 26944 | Start I Time | 17666 | 0x00 | 0x00 | 0x01 | 0x0e |
| 17602 | 704 | Start Pedestal | 17668 | 0x00 | 0x00 | 0x0c | 0xcd |
| 17603 | 21120 | iERS enabled | 17670 | 0x00 | 0x00 | 0x00 | 0x00 |
| 17604 | 21184 | iERS rate | 17672 | 0x00 | 0x00 | 0x00 | 0x00 |
| 17605 | 21320 | Start Saving Level | 17674 | 0x00 | 0x00 | 0x00 | 0x00 |

Using the above example, the gathered values may be seen in the following diagram. In this instance block setting of the 6 remapped registers is shown.

Communication

7.1 Modbus Register Address Aliasing (continued)

Set the 6 aliased addresses into 6 registers starting from 17600. Note, there can be up to 16 addresses.

The screenshot shows the Modbus software interface with the following configuration:

- Device:** 1
- Command:** Write Holding Register(s)
- # Registers:** 6
- Function:** 16
- Register:** 17600
- Options:** Loop Command, Error Checking, Show Error Dialog

The interface includes a **Start** button, a **Stop** button, and three digital displays for **Valid Response(s)**, **Error Response(s)**, and **Timeout(s)**, each with a **Reset** button. Below the displays are tabs for **Read Registers**, **Write Registers**, **Raw Data**, and **Data Log**. The **Write Registers** tab is active, showing a data table with the following values:

| | | | | | | | | | | | | | | | | |
|-----------|-------|-------|-----|-------|-------|-------|---|---|---|---|---|---|---|---|---|---|
| 001..016: | 26880 | 26944 | 704 | 21120 | 21184 | 21320 | 0 | 0 | 0 | 0 | 0 | 0 | 0 | 0 | 0 | 0 |
|-----------|-------|-------|-----|-------|-------|-------|---|---|---|---|---|---|---|---|---|---|

Block read the associated data from 17664 for 12 registers (two registers for each datum).

The screenshot shows the Modbus software interface with the following configuration:

- Device:** 1
- Command:** Read Holding Register(s)
- # Registers:** 12
- Function:** 3
- Register:** 17664
- Options:** Loop Command, Error Checking, Show Error Dialog

The interface includes a **Start** button, a **Stop** button, and three digital displays for **Valid Response(s)**, **Error Response(s)**, and **Timeout(s)**, each with a **Reset** button. Below the displays are tabs for **Read Registers**, **Write Registers**, **Raw Data**, and **Data Log**. The **Read Registers** tab is active, showing a data table with the following values:

| | | | | | | | | | | | | | | | | |
|-----------|-------|-------|-------|-------|-------|-------|-------|-------|-------|-------|-------|-------|---|---|---|---|
| 001..016: | 0000h | E86Ch | 0000h | 001Eh | 0000h | 0CCDh | 0000h | 0001h | 0000h | 1000h | 0000h | 0000h | - | - | - | - |
|-----------|-------|-------|-------|-------|-------|-------|-------|-------|-------|-------|-------|-------|---|---|---|---|

Optionally, the data can be modified and written back to the same registers.

The screenshot shows the Modbus software interface with the following configuration:

- Device:** 1
- Command:** Write Holding Register(s)
- # Registers:** 12
- Function:** 16
- Register:** 17664
- Options:** Loop Command, Error Checking, Show Error Dialog

The interface includes a **Start** button, a **Stop** button, and three digital displays for **Valid Response(s)**, **Error Response(s)**, and **Timeout(s)**, each with a **Reset** button. Below the displays are tabs for **Read Registers**, **Write Registers**, **Raw Data**, and **Data Log**. The **Write Registers** tab is active, showing a data table with the following values:

| | | | | | | | | | | | | | | | | |
|-----------|-------|-------|-------|-----|-------|------|-------|----|-------|-------|-------|-----|---|---|---|---|
| 001..016: | 0000h | E800h | 0000h | 1Fh | 0000h | CCCh | 0000h | 0h | 0000h | 1001h | 0000h | FFh | - | - | - | - |
|-----------|-------|-------|-------|-----|-------|------|-------|----|-------|-------|-------|-----|---|---|---|---|

Communication

7.1 Modbus Register Address Aliasing (continued)

Reading back from the same registers it can be seen all the modified data. Note that the last “Start Saving Level” datum has not changed, since 21320 is a Read only register.

The screenshot displays a Modbus communication interface. At the top, there is a configuration table for the device and command:

| Device | Command | # Registers | Function |
|--------|---|-------------|----------|
| 1 | <input checked="" type="radio"/> Read Holding Register(s) | 12 | 3 |
| | <input type="radio"/> Write Single Holding Register | | 6 |
| 17664 | <input type="radio"/> Write Holding Register(s) | 12 | 16 |

Below the configuration table, there are checkboxes for Loop Command, Error Checking, and Show Error Dialog. A **Start** button is visible.

The interface also features three digital displays: **Valid Response(s)** showing 4, **Error Response(s)** showing 0, and **Timeout(s)** showing 0. Each display has a **Reset** button.

At the bottom, there are tabs for **Read Registers**, **Write Registers**, **Raw Data**, and **Data Log**. The **Read Registers** tab is active, showing a table of register data:

| Address | Value | Value | Value | Value | Value | Value | Value | Value | Value | Value | Value | Value | Value | Value |
|----------|-------|-------|-------|-------|-------|-------|-------|-------|-------|-------|-------|-------|-------|-------|
| 001.016: | 0000h | E800h | 0000h | 001Fh | 0000h | 0CCCh | 0000h | 0000h | 0000h | 1001h | 0000h | 0000h | - | - |
| 017.032: | - | - | - | - | - | - | - | - | - | - | - | - | - | - |

Once set the addresses can be saved in non-volatile memory if required. However, given that this is a programmable feature, best practice would be to program the aliases at the start of a PLC session. Saving can be done by either using the “Save Parameter” button in the Advanced section of the keypad, or by setting appropriate Modbus register (62144). The alias being processed may be cleared by setting each Alias Register Address to 0 or by performing a factory default.

Appendices

Appendix 1

A1.0 Updating VMX-Synergy Plus™ Firmware

1. Insert the USB flash drive into the USB connector on the VMX-Synergy Plus™ unit.

2. Use the touchscreen to navigate to the Update Firmware selection button. Home >> Device >> Update Firmware.

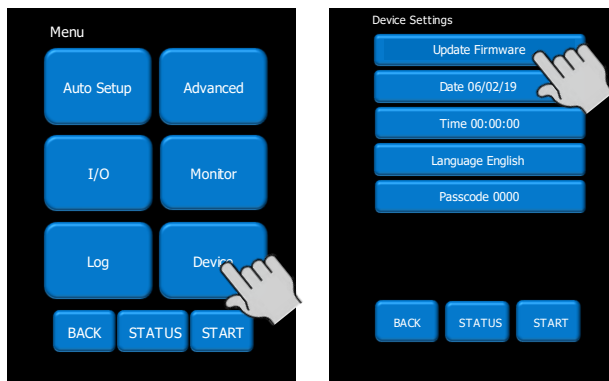

3. The next screen shows the 'current' installed firmware version and the firmware version previously copied to the USB flash drive. Press the Start Firmware Update button. Confirm the update

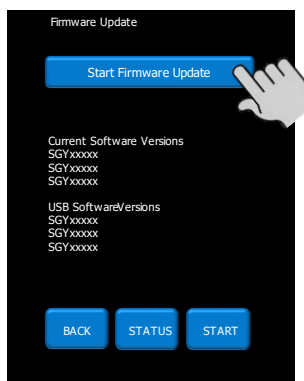

ENSURE POWER IS NOT REMOVED FROM THE UNIT DURING THE FIRMWARE UPDATE

Appendices

A1.1 Updating VMX-Synergy Plus™ Keypad Firmware

1. Remove the keypad using the release points shown in Section 2.9 -External Features
2. Insert the USB flash drive into the USB connector on the Keypad.

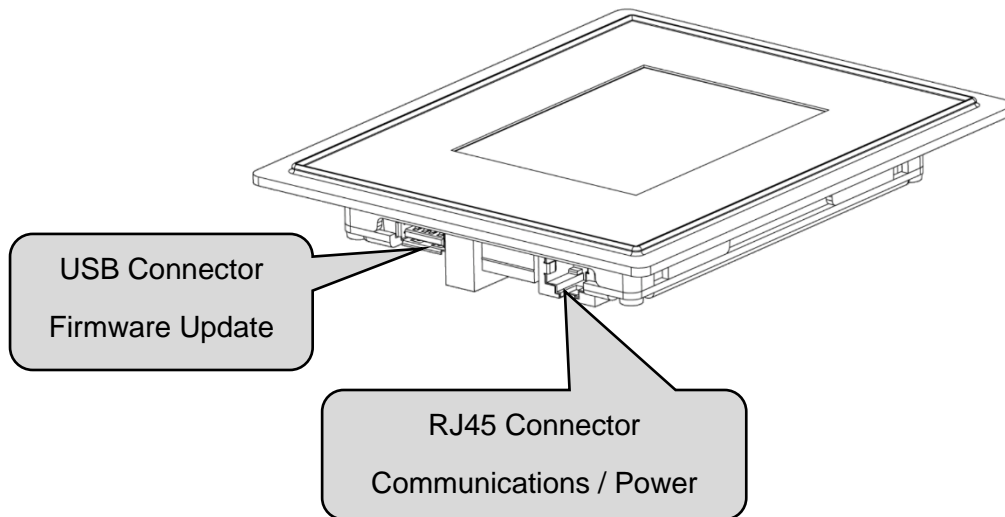

2. Use the touchscreen to navigate to the Update Firmware selection button. Home >> Device >> Update Firmware.

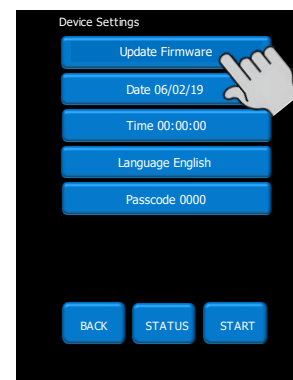
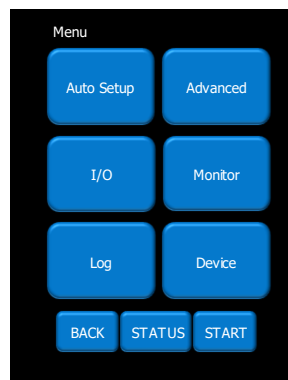

3. The next screen shows the 'current' installed firmware version and the firmware version previously copied to the USB flash drive. Press the Start Firmware Update button. Confirm the update

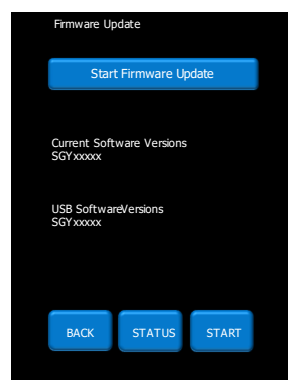

ENSURE POWER IS NOT REMOVED FROM THE UNIT DURING THE FIRMWARE UPDATE

Appendices

Appendix 2

A2.0 Remote Installation of the Touchscreen

If required, the VMX-Synergy Plus™ touchscreen may be removed and located remotely – for instance, on the enclosure door.

Procedure

1. Remove keypad from front of unit.
2. Remove short cable
3. Peel off backing on one side only of the provided pressure sensitive adhesive gasket. Attach the gasket to the back of the keypad.
4. Peel off the backing from the gasket attached to the keypad.
5. Place keypad on the outside of door or panel with a 91mm (3.6") (91mm) by 112 mm (4.4") inch cutout.
6. Attach the long cable to the keypad in place of the removed short one.
7. Remove orientation label after install is complete.

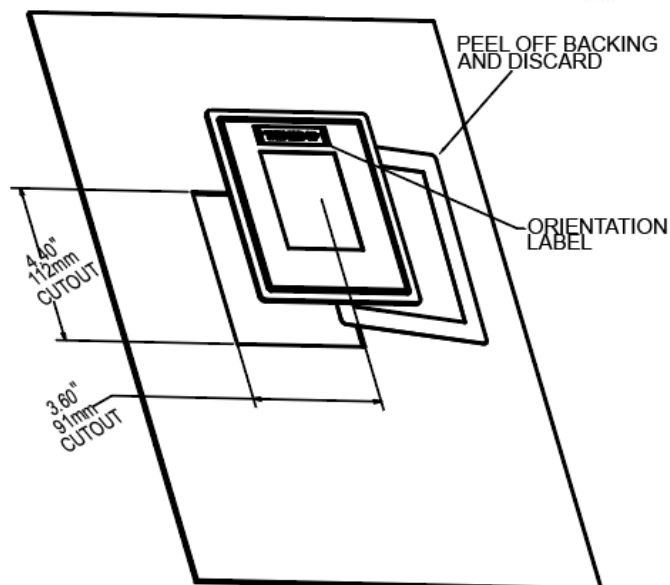
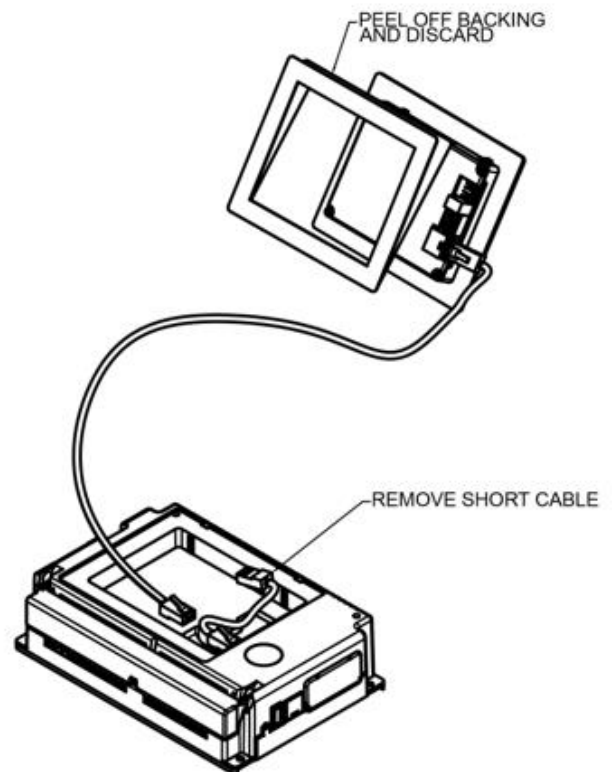

Electric current, Danger to life!

Only skilled or instructed persons may carry out the operations.

Lebensgefahr durch Strom!

Nur Elektrofachkräfte und elektrotechnisch unterwiesene Personen dürfen die im Folgenden beschriebenen Arbeiten ausführen.

Tension électrique dangereuse!

Seules les personnes qualifiées et averties doivent exécuter les travaux ci-après.

¡Corriente eléctrica! ¡Peligro de muerte!

El trabajo a continuación descrito debe ser realizado por personas cualificadas y advertidas.

Tensione elettrica: Pericolo di morte!

Solo persone abilitate e qualificate possono eseguire le operazioni di seguito riportate.

触电危险!

只允许专业人员和受过专业训练的人员进行下列工作。

Электрический ток! Опасно для жизни!

Только специалисты или проинструктированные лица могут выполнять следующие операции.

Levensgevaar door elektrische stroom!

Uitsluitelijk deskundigen in elektriciteit en elektrotechnisch geïnstrueerde personen is het toegestaan, de navolgend beschrevene werkzaamheden uit te voeren.

Livsfare på grund af elektrisk strøm!

Kun uddannede el-installatører og personer der er instruerede i elektrotekniske arbejdsopgaver, må udføre de nedenfor anførte arbejder.

Προσοχή, κίνδυνος ηλεκτροπληξίας!

Οι εργασίες που αναφέρονται στη συνέχεια θα πρέπει να εκτελούνται μόνο από ηλεκτρολόγους και ηλεκτροτεχνίτες.

Perigo de vida devido a corrente eléctrica!

Apenas electricistas e pessoas com formação electrotécnica podem executar os trabalhos que a seguir se descrevem.

Livsfara genom elektrisk ström!

Endast utbildade elektriker och personer som undervisats i elektroteknik får utföra de arbeten som beskrivs nedan.

Hengenvaarallinen jännite!

Vain pätevät sähköasentajat ja opastusta saaneet henkilöt saavat suorittaa seuraavat työt.

Nebezpečí úrazu elektrickým proudem!

Níže uvedené práce smějí provádět pouze osoby s elektrotechnickým vzděláním.

Eluotlik! Elektrilöögiolt!

Järgnevalt kirjeldatud töid tohib teostada ainult elektriala spetsialist või elektrotehnilise instrueerimise läbinud personal.

Életveszély az elektromos áram révén!

Csak elektromos szakemberek és elektrotechnikában képzett személyek végezhetik el a következőkben leírt munkákat.

Elektriská stráva apdraud dzīvību!

Tālāk aprakstītos darbus drīkst veikt tikai elektrospeciālisti un darbam ar elektrotehniskām iekārtām instruētās personas!

Porażenie prądem elektrycznym stanowi zagrożenie dla życia!

Opisane poniżej prace mogą przeprowadzać tylko wykwalifikowani elektrycy oraz osoby odpowiednio poinstruowane w zakresie elektrotechniki.

Livsfara genom elektrisk ström!

Endast utbildade elektriker och personer som undervisats i elektroteknik får utföra de arbeten som beskrivs nedan.

Hengenvaarallinen jännite!

Vain pätevät sähköasentajat ja opastusta saaneet henkilöt saavat suorittaa seuraavat työt.

Nebezpečí úrazu elektrickým proudem!

Níže uvedené práce smějí provádět pouze osoby s elektrotechnickým vzděláním.

Eluotlik! Elektrilöögiolt!

Järgnevalt kirjeldatud töid tohib teostada ainult elektriala spetsialist või elektrotehnilise instrueerimise läbinud personal.

Életveszély az elektromos áram révén!

Csak elektromos szakemberek és elektrotechnikában képzett személyek végezhetik el a következőkben leírt munkákat.

Elektriská stráva apdraud dzīvību!

Tālāk aprakstītos darbus drīkst veikt tikai elektrospeciālisti un darbam ar elektrotehniskām iekārtām instruētās personas!

Pavojus gyvybei dėl elektros srovės!

Tik elektrikai ir elektrotechnikos specialistai gali atlikti žemiau aprašytus darbus.

Porażenie prądem elektrycznym stanowi zagrożenie dla życia!

Opisane poniżej prace mogą przeprowadzać tylko wykwalifikowani elektrycy oraz osoby odpowiednio poinstruowane w zakresie elektrotechniki.

Življenjska nevarnost zaradi električnega toka!

Spodaj opisana dela smejo izvajati samo elektrostrokovnjaki in elektrotehnično poučene osebe.

Nebezpečnostvo ohrozenia života elektrickým prúdom!

Práce, ktoré sú nižšie opísané, smú vykonávať iba elektroodborníci a osoby s elektrotechnickým vzdelaním.

Опасност за живота от електрически ток!

Операциите, описани в следващите раздели, могат да се извършват само от специалисти-електротехници и инструктиран електротехнически персонал.

Atenție! Pericol electric!

Toate lucrările descrise trebuie efectuate numai de personal de specialitate calificat și de persoane cu cunoștințe profunde în electrotehnică.

Življenjska nevarnost zaradi električnega toka!

Spodaj opisana dela smejo izvajati samo elektrostrokovnjaki in elektrotehnično poučene osebe.

Nebezpečnostvo ohrozenia života elektrickým prúdom!

Práce, ktoré sú nižšie opísané, smú vykonávať iba elektroodborníci a osoby s elektrotechnickým vzdelaním.

Опасност за живота от електрически ток!

Операциите, описани в следващите раздели, могат да се извършват само от специалисти-електротехници и инструктиран

Atenție! Pericol electric!

Toate lucrările descrise trebuie efectuate numai de personal de specialitate calificat și de persoane cu cunoștințe profunde în electrotehnică.

Pavojus gyvybei dėl elektros srovės!

Tik elektrikai ir elektrotechnikos specialistai gali atlikti žemiau aprašytus darbus.

California Customers: California Proposition 65 Warning

WARNING: this product and associated accessories may contain chemicals known to the State of California to cause cancer, birth defects, or other reproductive harm. For more information visit <https://p65warnings.ca.gov>

For further regulatory information, please see Article33 Declaration on website. Unit specific SCIP details are also available upon request.

To assist with assessing your Environmental Impact, International Recycling codes are printed/stamped on unit boxes, to cover all enclosed packaging materials.

Motortronics UK aim to ensure that any battery used within their products is readily removable and replaceable by the end-user. Instructions on this are available on the Motortronics website.



MOTORTRONICS™

Solid State AC Motor Control

VMX-Synergy Plus™

Premium Digital Soft Starter

www.motortronics.com