



**INVERTER**

**INSTRUCTION MANUAL**

---

*Brake Unit*

**FR-BU2-1.5K to 55K**

**FR-BU2-H7.5K to H280K**

Thank you for choosing this Mitsubishi Inverter option unit.

This Instruction Manual gives handling information and precautions for use of this equipment. Incorrect handling might cause an unexpected fault. Before using the equipment, please read this manual carefully to use the equipment to its optimum performance.

Please forward this manual to the end user.

## This section is specifically about safety matters

Do not attempt to install, operate, maintain or inspect this product until you have read through this Instruction Manual and appended documents carefully and can use the equipment correctly. Do not use this product until you have a full knowledge of the equipment, safety information and instructions. In this instruction manual, the safety instruction levels are classified into "WARNING" and "CAUTION".



### WARNING

Incorrect handling may cause hazardous conditions, resulting in death or severe injury.



### CAUTION

Incorrect handling may cause hazardous conditions, resulting in medium or slight injury, or may cause only material damage.

The **CAUTION** level may even lead to a serious consequence according to conditions. Both instruction levels must be followed because these are important to personal safety.

## SAFETY INSTRUCTIONS

### 1. Electric Shock Prevention



### WARNING

- While the inverter power is ON, do not open the front cover or the wiring cover. Do not run the inverter with the front cover or the wiring cover removed. Otherwise you may access the exposed high voltage terminals or the charging part of the circuitry and get an electric shock.
- Even if power is OFF, do not remove the front cover except for wiring or periodic inspection. You may accidentally touch the charged inverter connected to the brake unit and get an electric shock.
- Before wiring or inspection, power must be switched OFF. To confirm that, the 3-digit monitoring LED of the brake unit must be checked. (It must be OFF.) Any person who is involved in wiring or inspection shall wait for at least 10 minutes after the power supply has been switched OFF and check that there are no residual voltage using a tester or the like. The brake unit, the discharging resistor, and the connected inverter are charged with high voltage for some time after power OFF, and it is dangerous.
- This brake unit must be earthed (grounded).
- Any person who is involved in wiring or inspection of this equipment shall be fully competent to do the work.
- The brake unit must be installed before wiring. Otherwise you may get an electric shock or be injured.
- Do not touch the switches or handle the cables with wet hands. Otherwise you may get an electric shock.
- Do not subject the cables to scratches, excessive stress, heavy loads or pinching. Otherwise you may get an electric shock.

### 2. Fire Prevention



### CAUTION

- The brake unit, the resistor unit, and the discharging resistor must be installed on a nonflammable wall without holes. Mounting it to or near flammable material can cause a fire.
- A sequence that will turn OFF power when a fault signal is output must be configured. Otherwise the brake resistor may overheat due to damage of the brake transistor and possibly cause a fire.
- Do not connect a resistor unit or discharging resistor directly to the DC terminals P/+ and N/-. Doing so could cause a fire.
- Be sure to perform daily and periodic inspections as specified in the Instruction Manual. If a product is used without any inspection, a burst, breakage, or a fire may occur.

### 3. Injury Prevention



### CAUTION

- The voltage applied to each terminal must be the ones specified in the Instruction Manual. Otherwise burst, damage, etc. may occur.
- The cables must be connected to the correct terminals. Otherwise burst, damage, etc. may occur.
- Polarity must be correct. Otherwise burst, damage, etc. may occur.
- While power is ON or for some time after power-OFF, do not touch the discharging resistor and the resistor unit because they will be extremely hot. Doing so can cause burns.

#### 4. Additional Instructions

Also the following points must be noted to prevent an accidental failure, injury, electric shock, etc.

##### (1) Transportation and mounting

<b>⚠ CAUTION</b>	
<ul style="list-style-type: none"> <li>• The product must be transported in correct method that corresponds to the weight. Failure to do so may lead to injuries.</li> <li>• Do not stack the boxes containing the product higher than the number recommended.</li> <li>• The product must be installed to the position where withstands the weight of the product according to the information in the Instruction Manual.</li> <li>• Do not install or operate the brake unit if it is damaged or has parts missing.</li> <li>• When carrying the brake unit, do not hold it by the front cover; it may fall off or fail.</li> <li>• Do not stand or rest heavy objects on the product.</li> <li>• The mounting orientation must be correct.</li> <li>• Foreign conductive bodies must be prevented to enter the brake unit. That includes screws and metal fragments or other flammable substance such as oil.</li> <li>• As the brake unit is a precision instrument, do not drop or subject it to impact.</li> <li>• The brake unit must be used under the following environment: Otherwise the brake unit may be damaged.</li> </ul>	

Environment	Surrounding air temperature	-10°C to +50°C (non-freezing)
	Ambient humidity	90%RH or less (non-condensing)
	Storage temperature	-20°C to +65°C *1
	Atmosphere	Indoors (free from corrosive gas, flammable gas, oil mist, dust and dirt)
	Altitude/vibration	Maximum 1,000m above sea level. 5.9m/s <sup>2</sup> or less at 10 to 55Hz (directions of X, Y, Z axes)

\*1 Temperature applicable for a short time, e.g. in transit.

- If halogen-based materials (fluorine, chlorine, bromine, iodine, etc.) infiltrate into a Mitsubishi product, the product will be damaged. Halogen-based materials are often included in fumigant, which is used to sterilize or disinfect wooden packages. When packaging, prevent residual fumigant components from being infiltrated into Mitsubishi products, or use an alternative sterilization or disinfection method (heat disinfection, etc.) for packaging. Sterilization of disinfection of wooden package should also be performed before packaging the product.

##### (2) Trial run

<b>⚠ CAUTION</b>	
<ul style="list-style-type: none"> <li>• Before starting operation, each parameter must be confirmed and adjusted. If the parameters setting in the brake unit is different from the type of the connected resistor, optimum operation may not be performed, the resistor may overheat, and a fault may be output.</li> </ul>	

##### (3) Usage

<b>⚠ WARNING</b>	
<ul style="list-style-type: none"> <li>• Do not modify the equipment.</li> <li>• Do not perform parts removal which is not instructed in this manual. Doing so may lead to fault or damage of the product.</li> </ul>	

##### (4) Emergency stop

<b>⚠ CAUTION</b>	
<ul style="list-style-type: none"> <li>• A safety backup such as an emergency brake must be provided to prevent hazardous conditions to the machine and equipment in case of inverter and brake unit failure.</li> </ul>	

##### (5) Maintenance, inspection and parts replacement

<b>⚠ WARNING</b>	
<ul style="list-style-type: none"> <li>• Do not carry out a megger (insulation resistance) test on the control circuit of the brake unit. It will cause a failure.</li> </ul>	

##### (6) Disposal

<b>⚠ CAUTION</b>	
<ul style="list-style-type: none"> <li>• The brake unit must be treated as industrial waste.</li> </ul>	

##### (7) General instruction

Many of the diagrams and drawings in this Instruction Manual show the brake unit without a cover or partially open for explanation. Never operate the brake unit in this manner. The cover must be always reinstalled and the instruction in this Instruction Manual must be followed when operating the brake unit.

## Brake unit (FR-BU2 type)

This option unit can be used with FR series inverters, which need large brake torque, such as when motor is rotated by a load or when rapid deceleration is required.

Following three types of discharging resistor or resistor unit as in the table can be connected to this option unit. FR-BU2 type brake unit can be used as substitute of the existing brake units (BU type, FR-BU-(H) type, MT-BU5 type).

Do not operate the conventional brake unit and FR-BU2 in parallel. Doing so could cause an alarm or failure. Change all units to the FR-BU2 to operate in parallel and connect the master/slave signal.

Compatible Discharging Resistor and Resistor Unit	Conventional Brake Unit
GRZG type discharging resistor	BU type
FR-BR-(H) type resistor unit	FR-BU-(H)
MT-BR5 type resistor unit	MT-BU5 type

Perform wiring and parameter setting referring to *page 16* as the wiring method and parameter setting method differ according to the discharging resistor or resistor unit combined.

# CONTENTS

1	PRODUCT CHECKING AND PARTS IDENTIFICATION .....	1
2	INSTALLATION .....	3
3	WIRING .....	5
3.1	Terminals .....	5
3.1.1	Brake unit .....	5
3.1.2	Resistor unit .....	12
3.2	Combinations of Discharging Resistors and Brake Unit for Brake Unit and Used Wires .....	14
3.3	External Connection Diagram .....	15
3.3.1	Connection with the inverter .....	15
3.4	Connection Example with the GRZG Type Discharging Resistor ...	17
3.4.1	When connecting one inverter and one brake unit .....	17
3.4.2	When connecting several brake units to one inverter .....	19
3.5	FR-BR-(H) Connection Example with Resistor Unit .....	21
3.5.1	When connecting one inverter and one brake unit .....	21
3.5.2	When connecting several brake units to one inverter .....	22
3.6	Connection Example with MT-BR5 Type Resistor Unit .....	24
3.6.1	When connecting one inverter and one brake unit .....	24
3.6.2	When connecting several brake units to one inverter .....	26
3.7	Wiring Instructions .....	28
4	OPERATION .....	30
4.1	Operation Panel .....	30
4.2	Basic Operation .....	31
4.3	Parameter List .....	32
4.3.1	Brake mode selection (Pr.0) .....	33
4.3.2	Multi-function monitor display (Pr.1, Pr.78) .....	34
4.3.3	Input terminal function selection (Pr.2, Pr.3) .....	36
4.3.4	Parameter write disable selection (Pr. 77) .....	37
4.3.5	Parameter clear .....	38
4.3.6	Faults history clear .....	39
5	PROTECTIVE FUNCTIONS .....	40
5.1	Reset method of protective function .....	40

5.2 Causes and Corrective Actions .....	41
5.3 Correspondence Between Digital and Actual Characters .....	43
<b>6 SPECIFICATIONS.....</b>	<b>44</b>
6.1 Brake Unit .....	44
6.2 Discharging Resistor/Resistor Unit.....	45
<b>7 PRECAUTIONS FOR MAINTENANCE AND INSPECTION.....</b>	<b>46</b>
7.1 Precautions for Maintenance and Inspection .....	46
7.2 Inspection Item.....	46
7.3 Periodic Inspection.....	47
7.4 Daily and Periodic Inspection.....	48
7.5 Replacement of Parts.....	50
<b>8 SELECTION .....</b>	<b>51</b>
<b>9 OUTLINE DIMENSION DRAWINGS.....</b>	<b>55</b>
<b>10 INSTRUCTIONS FOR COMPLIANCE WITH THE EU DIRECTIVES (400V CLASS ONLY).....</b>	<b>60</b>
<b>11 INSTRUCTIONS FOR UL, cUL COMPLIANCE .....</b>	<b>62</b>

# 1 PRODUCT CHECKING AND PARTS IDENTIFICATION

- (1) Unpack the option unit and confirm that the product is as you ordered and intact.

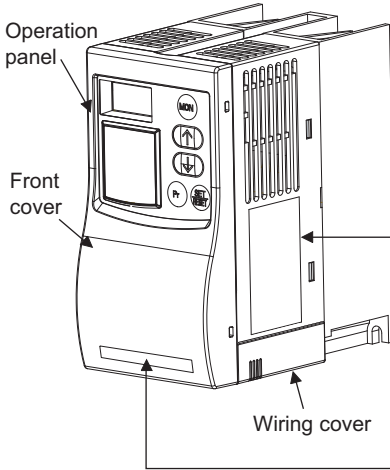

Rating plate

		BRAKE UNIT
<b>MODEL FR-BU2-15K</b>		
POWER SUPPLY : DC400V max for 200V class INVERTER		
SERIAL : _____		
MITSUBISHI ELECTRIC CORPORATION MADE IN JAPAN		PASSED

MODEL FR-BU2- H   K

No.	Applied power supply voltage	Applied motor capacity (kW)
Not used	200V class	
H	400V class	

Capacity plate

FR-BU2-15K	XXXXXX
------------	--------

Brake unit type SERIAL number

- (2) Make sure that the package includes all items.

Brake unit (FR-BU2)..... 1	Instruction manual ..... 1
----------------------------	----------------------------

**75K or less**

- Removal and reinstallation of the front cover

Remove the front cover by pulling it toward you in the direction of arrow. To reinstall, match the cover to the brake unit front and install it straight.
- Removal and reinstallation of the wiring cover

The cover can be removed easily by pulling it toward you. To reinstall, fit the cover to the brake unit along the guides.

220K or more

- Removal and reinstallation of the front cover 1

Remove the installation screws of the front cover 1, and remove the front cover 1.

To reinstall, securely install the front cover 1 using the installation screws of the front cover 1.

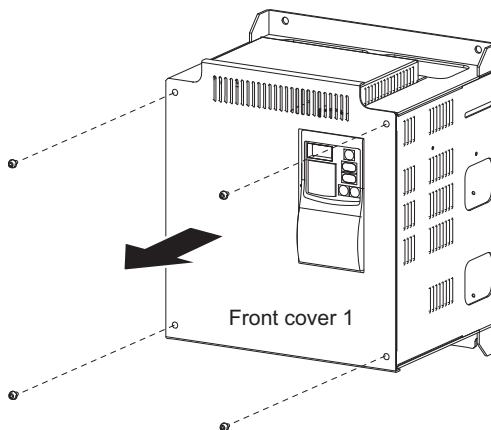

- Removal and reinstallation of the front cover 2

Remove the front cover 2 by pulling it toward you in the direction of the arrow.

To reinstall, match the cover to the brake unit front and install it straight.

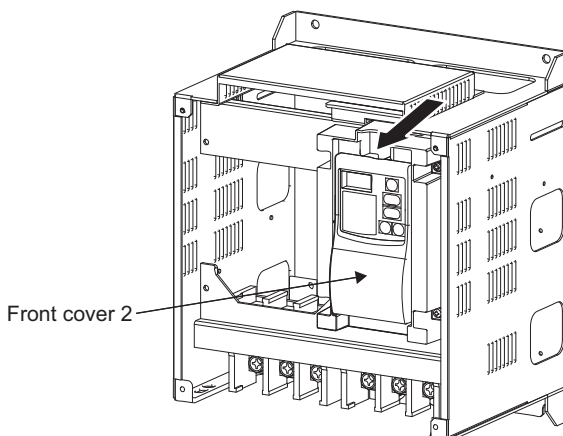



## 2 INSTALLATION

Enclosure surface mounting

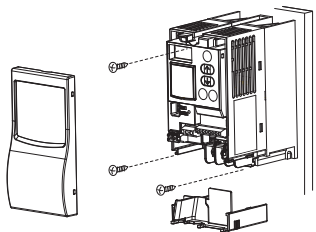

Remove the front cover and wiring cover to fix the brake unit to the surface.

Leave enough clearances as a cooling measure.

Encasing multiple brake units

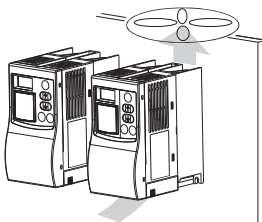

When encasing multiple brake units, install them in parallel as a cooling measure.

Install the brake unit under the following conditions.

Vertical mounting

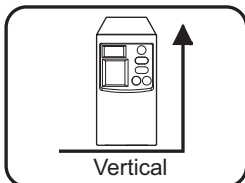

Surrounding air temperature and humidity

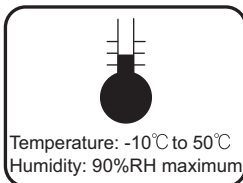

Clearances

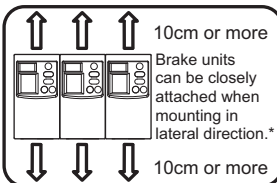



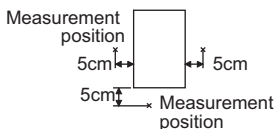



Brake unit

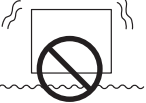

\* Permissible surrounding air temperature is  $-10^{\circ}\text{C}$  to  $40^{\circ}\text{C}$  when mounting brake units closely-attached. When surrounding air temperature exceeds  $40^{\circ}\text{C}$ , clearances between brake units should be 1cm or more.  
When using brake units with 75K or higher capacities, these brake units need clearance between them.

The brake unit consists of precision mechanical and electronic parts. Never install or handle it in any of the following conditions as doing so could cause an operation fault or failure.

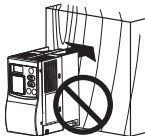
 <p>Direct sunlight</p>	 <p>Vibration (<math>5.9\text{m/s}^2</math> or more at 10 to 55Hz (directions of X, Y, Z axes))</p>	 <p>High temperature, high humidity</p>	 <p>Horizontal placement</p>
 <p>Vertical mounting (when mounting inside an enclosure)</p>	 <p>Transportation by holding the front cover</p>	 <p>Oil mist, flammable gas, corrosive gas, fluff, dust, etc.</p>	 <p>Mounting to flammable material</p>

## CAUTION

**Mount the brake unit and resistor unit to nonflammable material. Installing it to flammable materials directly or near flammable materials can cause a fire.**

# 3 WIRING

## 3.1 Terminals

### 3.1.1 Brake unit

Terminal Symbol		Terminal Name	Description	Rating	
Main circuit	P/+	Brake unit input terminal	Connect to the inverter terminal P and N.	—	
	N/-				
	PR*1	Resistor connection terminal	Connect the discharging resistor or resistor unit.		
		Earth (Ground)	For earthing (grounding) the brake unit. Must be earthed (grounded).		
Control circuit	Contact input	BUE	Brake operation permission signal Controls the brake operation. Turning ON the signal enables brake operation. *2	Voltage at opening : 21 to 27VDC Controls by open collector output or no voltage contact signal.	
		RES	Reset input Used to reset fault output provided when protective circuit is activated. Turn ON the RES signal for more than 0.1s, then turn it OFF.		
		SD *4	Contact input common (sink logic) (initial setting)		Common terminal for contact input terminal and brake transistor driving signal terminal (terminal MSG). *3
			External transistor common (source logic)		When connecting the transistor output (open collector output), such as a programmable controller, connect the external power supply common for transistor output to this terminal to prevent a malfunction caused by undesirable currents.
	Master/slave signal	MSG *4	Brake transistor driving signal	Brake transistor driving signal terminal *3	—

\*1 Do not connect devices other than discharging resistor and resistor unit to terminal PR. Connecting other devices may cause damage to the brake unit.

\*2 BUE and SD is connected with a jumper in the initial status. Remove the jumper when using this signal. (When terminals are open, brake unit is not operated.)

To change the logic of the brake unit to source, short across terminals BUE and PC.

\*3 For master/slave operation, when connecting several brake units to one inverter in parallel, connect this signal to terminals of other brake units.

\*4 Do not connect terminals SD, PC and MSG each other or to the ground. Doing so may damage the brake unit.

For sink logic (initial status), terminal SD acts as the common terminal of contact input. For source logic, terminal PC acts as the common terminal of contact input.

Terminal Symbol		Terminal Name	Description	Rating
Control circuit	Contact input	PC *4	External transistor common (sink logic) (initial setting)	—
			Contact input common (source logic)	
Control circuit	Relay output	A	1 changeover contact output indicates that the brake unit protective function has activated. Normal Across B and C: Continuity Across A and C: Discontinuity Fault Across B and C: Discontinuity Across A and C: Continuity	230VAC 0.3A 30VDC 0.3A
		B		
		C		

\*4 Do not connect terminals SD, PC and MSG each other or to the ground.

Doing so may damage the brake unit.

For sink logic (initial status), terminal SD acts as the common terminal of contact input. For source logic, terminal PC acts as the common terminal of contact input.

•Terminal arrangement of the main circuit terminals

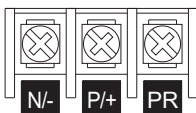

Cable size of the main circuit terminals

Brake Unit Model	Main Circuit Terminal Screw Size	Crimping Terminal	Tightening Torque (N • m)	Cable Size					
				HIV cables, etc. (mm <sup>2</sup> )		AWG	PVC cables, etc. (mm <sup>2</sup> )		
				N/- P/+ , PR	Earthing cable	N/- P/+ , PR	N/- P/+ , PR	Earthing cable	
200V	FR-BU2-1.5K/3.7K	M4	2-4	1.5	2	2	14	2.5	2.5
	FR-BU2-7.5K	M4	5.5-4	1.5	3.5	3.5	12	4	4
	FR-BU2-15K	M4	5.5-4	1.5	3.5	3.5	12	4	4
	FR-BU2-30K	M5	5.5-5	2.5	5.5	5.5	10	6	6
	FR-BU2-55K	M6	14-6	4.4	14	14	6	16	16
400V	FR-BU2-H7.5K	M4	2-4	1.5	2	2	14	2.5	2.5
	FR-BU2-H15K	M4	5.5-4	1.5	3.5	3.5	12	4	4
	FR-BU2-H30K	M4	5.5-4	1.5	3.5	3.5	12	4	4
	FR-BU2-H55K	M5	5.5-5	2.5	5.5	5.5	10	6	6
	FR-BU2-H75K	M6	14-6	4.4	14	14	6	16	16
	FR-BU2-H220K	M8	60-8	7.8	60	38	1/0	50	25
	FR-BU2-H280K	M8	60-8	7.8	60	38	1/0	50	25

•Control circuit terminal layout

A

B

C

PC

BUE

SD

RES

SD

MSG

MSG

SD

SD

Loosen the terminal screw and insert the cable into the terminal.

- ☞ Screw size : M3
- ☞ Tightening torque : 0.5N•m to 0.6N•m

---

**CAUTION**

---

**Undertightening can cause cable disconnection or malfunction. Overtightening can cause a short circuit or malfunction due to damage to the screw or unit.**

---

- ☞ Cable size : 0.3mm<sup>2</sup> to 0.75mm<sup>2</sup>
- ☞ Screwdriver : Small⊖ flat-blade screwdriver  
(Tip thickness : 0.4mm / tip width : 2.5mm)

Wire the stripped wire after twisting it to prevent it from becoming loose. In addition, do not solder it.

Wire stripping length

6mm

Ferrule terminals available on the market: (as of Feb. 2012)

•Phoenix Contact Co., Ltd.

Wire Size (mm <sup>2</sup> )	Ferrule Terminal Model		Crimping tool name
	with insulation sleeve	without insulation sleeve	
0.3, 0.5	AI 0,5-6WH	A 0,5-6	CRIMPFOX 6
0.75	AI 0,75-6GY	A 0,75-6	

---

**CAUTION**

---

**When using the ferrule terminal (without insulation sleeve), use care so that the twisted wires do not come out.**

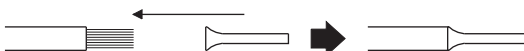



• Changing the control logic  
The input signals are set to sink logic when shipped from the factory.

To change the control logic, the jumper connector under the operation panel must be moved to the other position.

- Change the jumper connector in the sink logic position to source logic position using tweezers, a pair of long-nose pliers, etc. Change the jumper connector position before switching power ON.

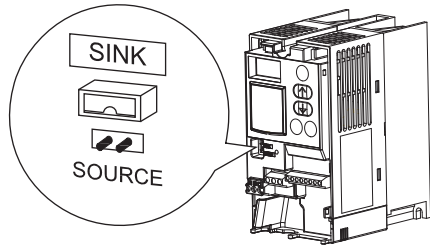

---

### CAUTION

---

- Fully make sure that the front cover has been reinstalled securely.
  - The front cover is fitted with the capacity plate, and the brake unit with the rating plate. Before reinstalling the front cover, check the serial numbers to ensure that the cover removed is reinstalled to the brake unit from where it was removed.
  - The sink-source logic change-over jumper connector must be fitted in only one of those positions. If it is fitted in both positions at the same time, the brake unit may be damaged.
-

1) Sink logic type

- In sink logic, a signal switches ON when a current flows from the corresponding signal input terminal.  
Terminal SD is common to the contact input signals.

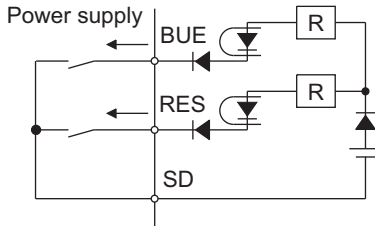

- Connect a positive terminal of the external power supply for transistor output to terminal PC.  
(Do not connect terminal SD of the brake unit with terminal 0V of the external power supply.)

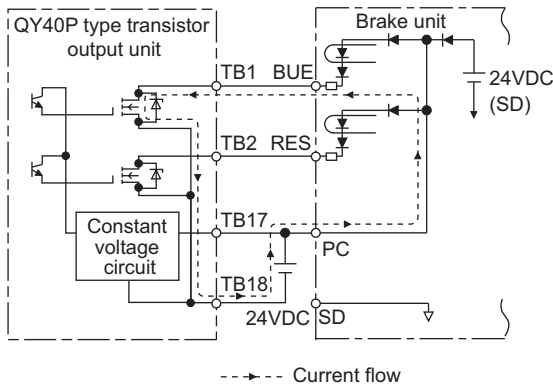



2) Source logic type

- In this logic, a signal switches ON when a current flows into the corresponding signal input terminal.  
Terminal PC is common to the contact input signals.

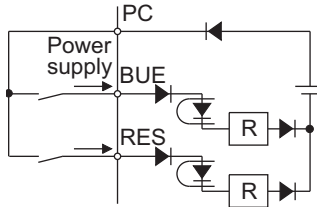

- Connect a 0V terminal of the external power supply for transistor output to terminal SD.  
(Do not connect terminal PC of the brake unit with terminal +24V of the external power supply.)

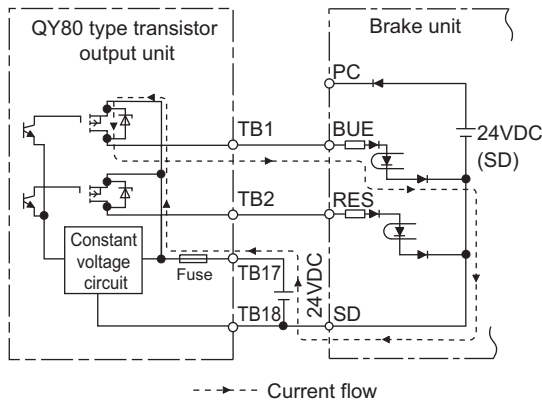

### 3.1.2 Resistor unit

#### (1) FR-BR-(H)

Terminal Symbol		Terminal Name	Description	Rating
Main circuit	P	Resistor unit input resistance	Connect to terminal P and PR of the brake unit.	—
	PR			
Control circuit	TH1	Fault output terminal	Output signal indicates resistor overheat	1NC contact 110VAC 5A 220VAC 3A
	TH2			

• Terminal arrangement

Resistor unit input terminal

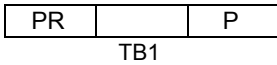

Control circuit terminal block arrangement

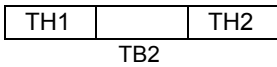

<FR-BR resistor unit>

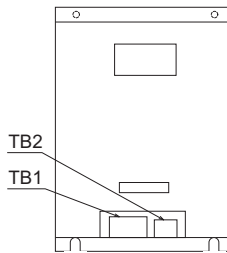

• Terminal screw size

Model		TB1	TB2
200V	FR-BR-15K	M4	M3.5
	FR-BR-30K	M5	M3.5
	FR-BR-55K	M6	M3.5
400V	FR-BR-H15K	M3.5	M3.5
	FR-BR-H30K	M4	M3.5
	FR-BR-H55K	M5	M3.5

(2) MT-BR5

Terminal Symbol		Terminal Name	Description	Rating
Main circuit	P	Resistor unit input terminal	Connect to terminal P and PR of the brake unit.	—
	PR			
	E	Earth terminal	For earthing (grounding) of the resistor unit. Must be earthed (grounded).	
Control circuit	TH1	Fault output terminal	Output signal indicates resistor overheat.	1 NO contact 110VAC 5A 220VAC 3A
	TH2			

• Terminal arrangement

Resistor unit input terminal

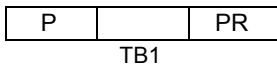

Control circuit terminal block arrangement

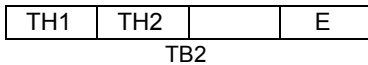

<MT-BR5 resistor unit>

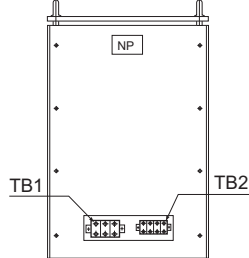

•Terminal screw size (MT-BR5)

Model	TB1	TB2
MT-BR5-55K	M6	M4
MT-BR5-H75K	M6	M4

### 3.2 Combinations of Discharging Resistors and Brake Unit for Brake Unit and Used Wires

Brake Unit Type		Discharging Resistor, Resistor Unit Type	Cable Size (mm <sup>2</sup> )
200V class	FR-BU2-1.5K	GZG 300W-50Ω (one)	2
	FR-BU2-3.7K	GRZG 200-10Ω (three in series)	2
	FR-BU2-7.5K	GRZG 300-5Ω (four in series)	3.5
	FR-BU2-15K	GRZG 400-2Ω (six in series)	3.5
		FR-BR-15K	
	FR-BU2-30K	FR-BR-30K	5.5
	FR-BU2-55K	FR-BR-55K	14
MT-BR5-55K			
400V class	FR-BU2-H7.5K	GRZG 200-10Ω (six in series)	2
	FR-BU2-H15K	GRZG 300-5Ω (eight in series)	3.5
		FR-BR-H15K	
	FR-BU2-H30K	GRZG 400-2Ω (twelve in series)	3.5
		FR-BR-H30K	
	FR-BU2-H55K	FR-BR-H55K	5.5
	FR-BU2-H75K	MT-BR5-H75K	14
	FR-BU2-H220K	3 × MT-BR5-H75K	3 × 14
FR-BU2-H280K	4 × MT-BR5-H75K	4 × 14	

### 3.3 External Connection Diagram

#### 3.3.1 Connection with the inverter

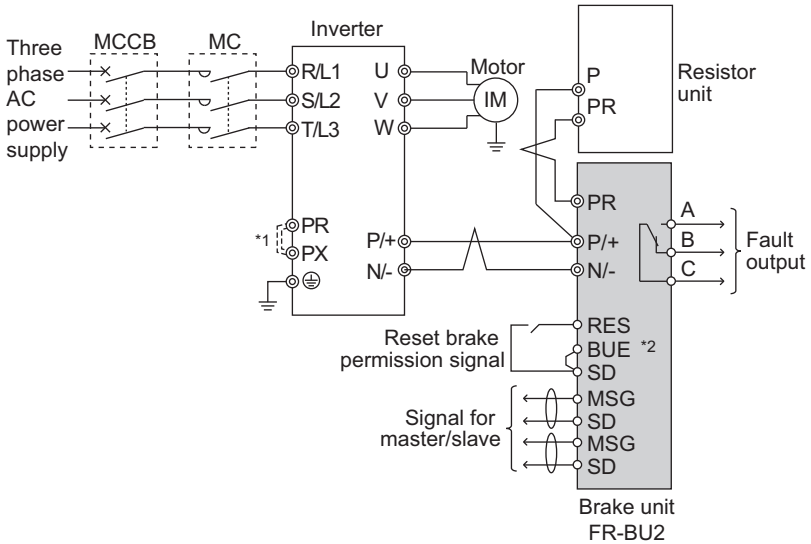

- \*1 When using the FR-BU2 with the inverter that has terminal PX, be sure to remove the jumper across terminal PR and PX.  
(A failure to do so may damage a built-in brake resistor.)
- \*2 A jumper is connected across BUE and SD in the initial status.

#### CAUTION

**Do not remove the jumper across terminal P/+ and P1 except when connecting a DC reactor.**

Connection method and parameter setting differ depending on the discharging resistor and resistor unit to be used with.

Refer to the page below depending on the discharging resistor and resistor unit.

Discharging Resistor, Resistor Unit	Refer to Page	
	Wiring	Parameter setting
GRZG	<i>17 to 19</i>	<i>33</i>
FR-BR-(H)	<i>21 to 22</i>	Setting change is unnecessary
MT-BR5	<i>24 to 26</i>	<i>33</i>

Each mark appears in the following pages explains below.

- **GRZG** ... Section of the GRZG type discharging resistor
- **FR-BR** .. Section of the FR-BR-(H) type resistor unit
- **MT-BR5** . Section of the MT-BR5 type resistor unit

## CAUTION

**Configure a protective circuit (shuts off power) corresponding to each discharging resistor and resistor unit as in the table below to prevent overheat of the discharging resistor and resistor unit to be combined.**

**Be sure to configure a sequence which detects overheat of a resistor to shut off power. If such circuit is not configured, it may result in resistor burnout, causing a fire.**

Discharging Resistor, Resistor Unit	Resistor Overheat Detection	Refer to Page
GRZG	Configure a sequence which shuts off power when the brake unit outputs a fault.	<i>17 to 19</i>
FR-BR-(H)	Configure a sequence which shuts off power without fail when a built-in thermal protector (NC contact) detects resistor overheat.	<i>21 to 22</i>
MT-BR5	Configure a sequence which shuts off power without fail when a built-in thermal protector (NO contact) detects resistor overheat.	<i>24 to 26</i>

### 3.4 Connection Example with the GRZG Type

#### Discharging Resistor

Configure a sequence which shuts off power when the brake unit outputs a fault signal to prevent burnout due to the temperature rise of the discharging resistor, in case the transistor inside the brake unit is damaged. In addition, it is recommended to configure a sequence which shuts off power in the input side by the external thermal relay connected to the discharging resistor. The external connection diagram is shown below.

#### 3.4.1 When connecting one inverter and one brake unit

- External connection diagram 1

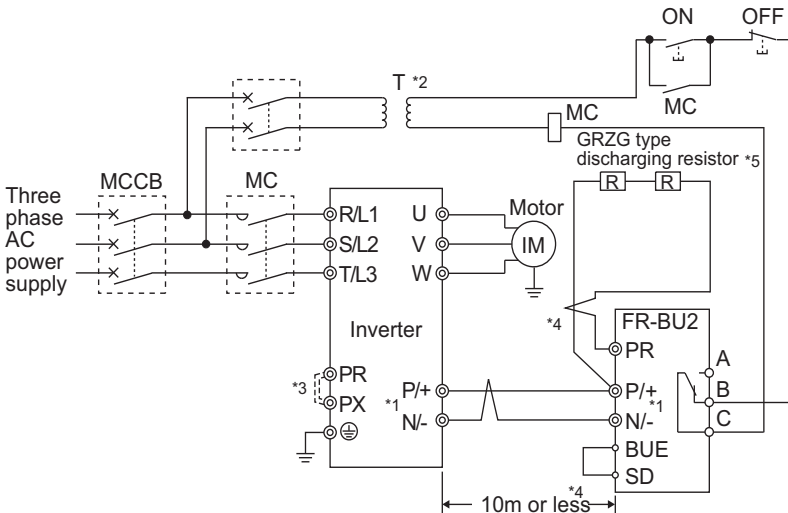

- \*1 Connect the inverter terminals (P/+, N/-) and brake unit (FR-BU2) terminals so that their terminal names match with each other. (Incorrect connection will damage the inverter and brake unit.)
- \*2 When the power supply is 400V class, install a stepdown transformer.
- \*3 When using the FR-BU2 with the inverter that has terminal PX, be sure to remove the jumper across terminal PR and PX.
- \*4 The wiring distance between the inverter and brake unit (FR-BU2), and between brake unit (FR-BU2) and discharging resistor should be within 5m. Even when the wire is twisted, the cable length must not exceed 10m. When twisting, twist at least 5 times per meter. The brake unit may be damaged if cables are not twisted when the wiring length is 5m or more or the wiring length exceeds 10m or more even if cables are twisted.
- \*5 It is recommended to install an external thermal relay to prevent overheat of discharging resistors. (Refer to page 18)

#### CAUTION

- Set "1" in Pr. 0 Brake mode selection of the FR-BU2 to use GRZG type discharging resistor. (Refer to page 33.)
- Do not remove the jumper across terminal P/+ and P1 except when connecting a DC reactor.

- External connection diagram 2 (When connecting an external thermal relay)

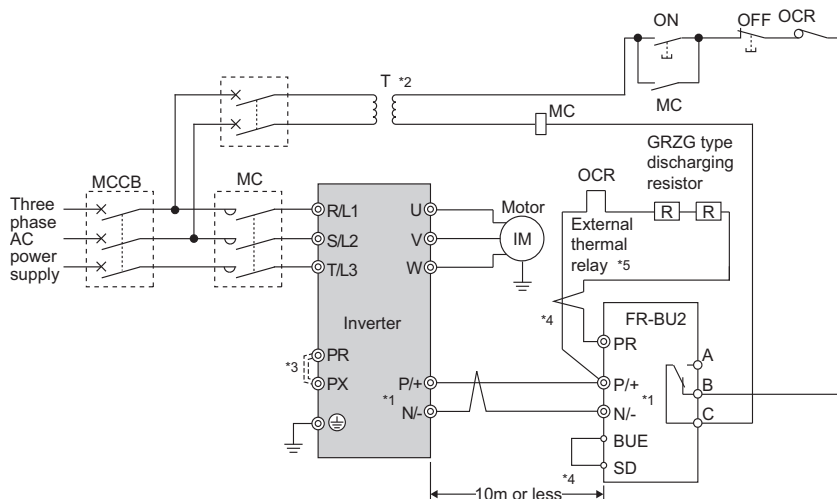

- \*1 Connect the inverter terminals (P/+, N/-) and brake unit (FR-BU2) terminals so that their terminal names match with each other. (Incorrect connection will damage the inverter and brake unit.)
- \*2 When the power supply is 400V class, install a stepdown transformer.
- \*3 When using the FR-BU2 with the inverter that has terminal PX, be sure to remove the jumper across terminal PR and PX.
- \*4 Keep a wiring distance of within 5m between the inverter, brake unit (FR-BU2) and discharging resistor. Even when the wiring is twisted, the cable length must not exceed 10m.
- \*5 It is recommended to install an external thermal relay to prevent overheat of discharging resistors.

<Recommended external thermal relay>

Brake Unit	Discharging Resistor	Recommended External Thermal Relay
FR-BU2-1.5K	GZG 300W-50Ω	TH-N20CXHZ 1.3A
FR-BU2-3.7K	GRZG 200-10Ω	TH-N20CXHZ 3.6A
FR-BU2-7.5K	GRZG 300-5Ω	TH-N20CXHZ 6.6A
FR-BU2-15K	GRZG 400-2Ω	TH-N20CXHZ 11A
FR-BU2-H7.5K	GRZG 200-10Ω	TH-N20CXHZ 3.6A
FR-BU2-H15K	GRZG 300-5Ω	TH-N20CXHZ 6.6A
FR-BU2-H30K	GRZG 400-2Ω	TH-N20CXHZ 11A

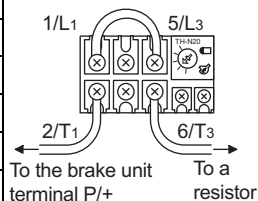

**CAUTION**

- Set "1" in Pr. 0 Brake mode selection of the FR-BU2 to use GRZG type discharging resistor. (Refer to page 33.)
- Do not remove the jumper across terminal P/+ and P1 except when connecting a DC reactor.



### 3.4.2 When connecting several brake units to one inverter GRZG

When connecting several brake units to one inverter, always use terminals (MSG, SD) that are for the master/slave operation wiring.

Parallel operation by master ↔ slave operation (10 units maximum)

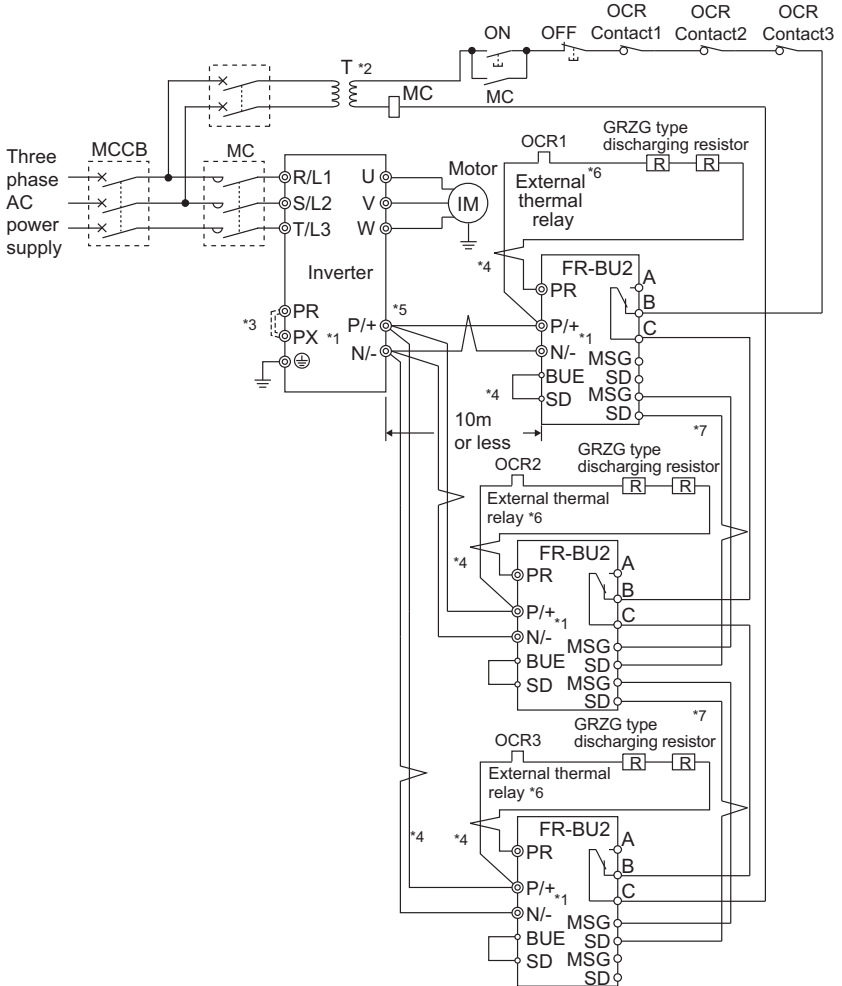

- \*1 Connect the inverter terminals (P/+, N/-) and brake unit (FR-BU2) terminals so that their terminal names match with each other. (Incorrect connection will damage the inverter and brake unit.)
- \*2 When the power supply is 400V class, install a stepdown transformer.
- \*3 When using the FR-BU2 with the inverter that has terminal PX, be sure to remove the jumper across terminal PR and PX.
- \*4 The wiring distance between the inverter and brake unit (FR-BU2), and between brake unit (FR-BU2) and discharging resistor should be within 5m. Even when the wire is twisted, the cable length must not exceed 10m. When twisting, twist at least 5 times per meter.  
The brake unit may be damaged if cables are not twisted when the wiring length is 5m or more or the wiring length exceeds 10m or more even if cables are twisted.
- \*5 When connecting several FR-BU2 to one inverter, connect P/+ of each FR-BU2 and of the inverter and N/- respectively. Do not pass wires from terminal P/+ and N/- of the FR-BU2 to terminals of other FR-BU2.  
When several peripheral devices are connected to the inverter and its terminals are fully used, set up a junction terminal block near terminals P/+ and N/- to connect a brake unit.
- \*6 It is recommended to install an external thermal relay to prevent overheat of discharging resistors.  
(Refer to page 18)
- \*7 The wiring length of the terminal MSG and SD should be 10m maximum. In addition, twist five times or more per 1m.

---

## CAUTION

---

- **Set "1" in Pr. 0 Brake mode selection of the FR-BU2 to use GRZG type discharging resistor.** (Refer to page 33.)
  - **Do not run the BU type brake unit and FR-BU2 in parallel. Doing so could cause an alarm or brake unit failure. Use the FR-BU2 only when performing parallel operation.**
  - **When connecting several brake units to one inverter, always connect terminals MSG and SD of one brake unit to the terminals MSG and SD of another brake unit. Incorrect wiring will cause damage to brake unit and discharging resistor.**
  - **Do not remove the jumper across terminal P/+ and P1 except when connecting a DC reactor.**
-

### 3.5 FR-BR-(H) Connection Example with Resistor Unit

FR-BR

Make up a sequence which always shuts off power in the input side by an overheat signal of the built-in thermal relay of the resistor unit in case a built-in transistor of the brake unit is damaged and configure a circuit which prevents the discharging resistor from abnormal overheating, leading to burnout.

The external connection diagram is shown below.

#### 3.5.1 When connecting one inverter and one brake unit FR-BR

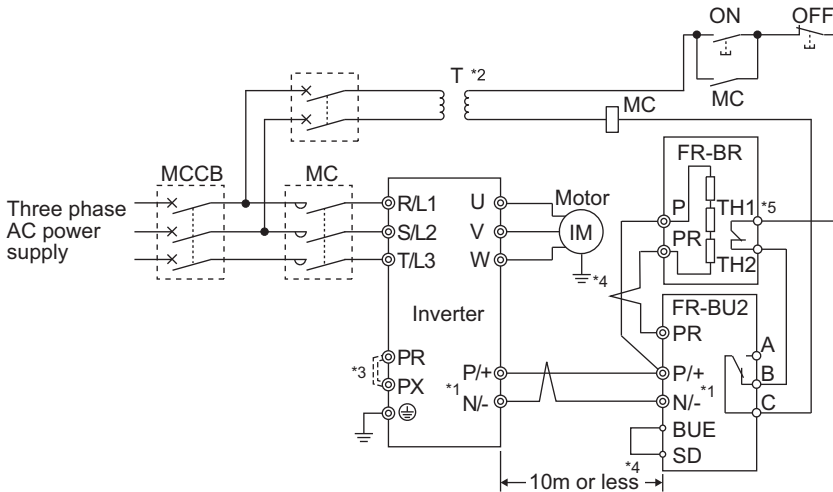

- \*1 Connect the inverter terminals (P/+, N/-) and brake unit (FR-BU2) terminals so that their terminal names match with each other. (Incorrect connection will damage the inverter and brake unit.)
- \*2 When the power supply is 400V class, install a stepdown transformer.
- \*3 When using the FR-BU2 with the inverter that has terminal PX, be sure to remove the jumper across terminal PR and PX.
- \*4 The wiring distance between the inverter and brake unit (FR-BU2), and between brake unit (FR-BU2) and discharging resistor should be within 5m. Even when the wiring is twisted, the cable length must not exceed 10m.
- \*5 The contact between TH1 and TH2 is closed in the normal status and is open at a fault.

#### CAUTION

- Do not remove the jumper across terminal P/+ and P1 except when connecting a DC reactor.

**3.5.2 When connecting several brake units to one inverter** FR-BR

When connecting several brake units to one inverter, always use terminals (MSG, SD) that are for the master/slave operation wiring.

Parallel operation by master ↔ slave operation (10 units maximum)

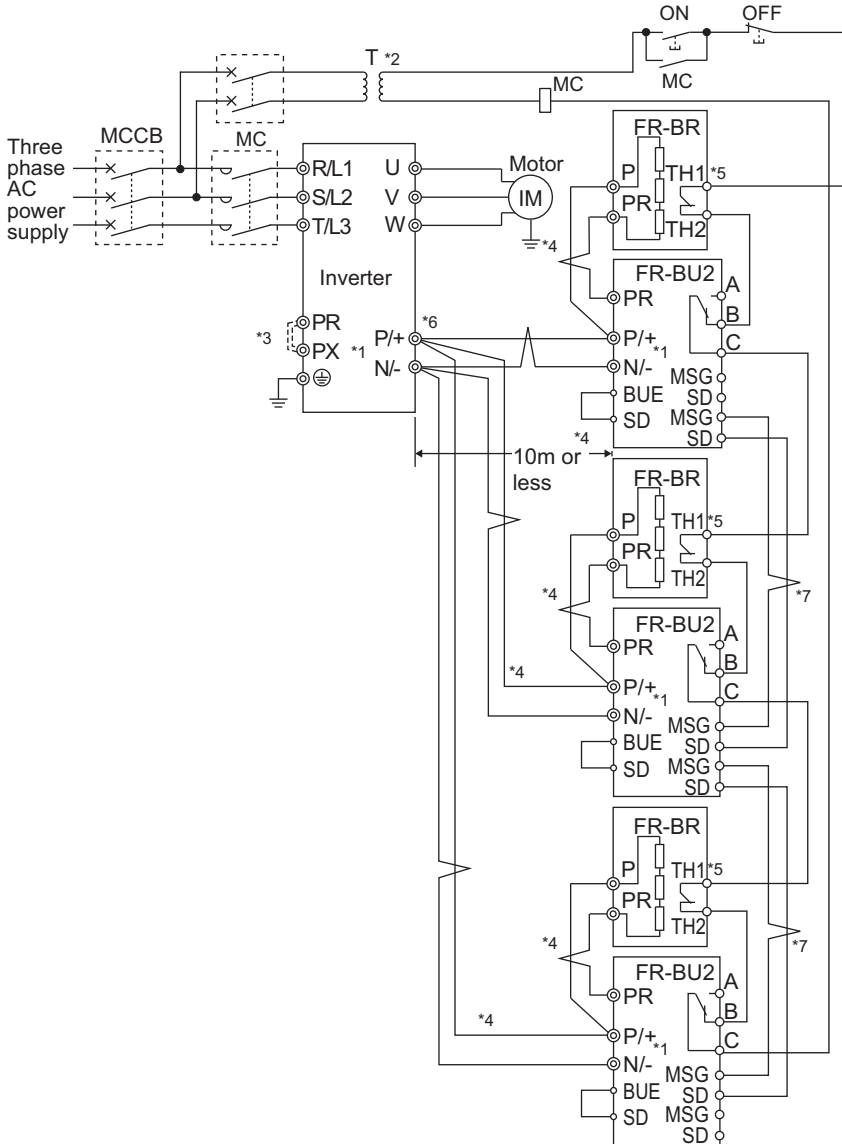

- \*1 Connect the inverter terminals (P/+, N/-) and brake unit (FR-BU2) terminals so that their terminal names match with each other. (Incorrect connection will damage the inverter and brake unit.)
- \*2 When the power supply is 400V class, install a stepdown transformer.
- \*3 When using the FR-BU2 with the inverter that has terminal PX, be sure to remove the jumper across terminal PR and PX.
- \*4 The wiring distance between the inverter and brake unit (FR-BU2), and between brake unit (FR-BU2) and discharging resistor should be within 5m. Even when the wiring is twisted, the cable length must not exceed 10m. When twisting, twist at least 5 times per meter. The brake unit may be damaged if cables are not twisted when the wiring length is 5m or more or the wiring length exceeds 10m or more even if cables are twisted.
- \*5 The contact between TH1 and TH2 is closed in the normal status and is open at a fault.
- \*6 When connecting several FR-BU2 to one inverter, connect P/+ of each FR-BU2 and of the inverter and N/- respectively. Do not pass wires from terminal P/+ and N/- of the FR-BU2 to terminals of other FR-BU2.  
When several peripheral devices are connected to the inverter and its terminals are fully used, set up a junction terminal block near terminals P/+ and N/- to connect a brake unit.
- \*7 The wiring length of the terminal MSG and SD should be 10m maximum. In addition, twist five times or more per 1m.

---

---

### CAUTION

---

---

- **When connecting several brake units to one inverter, always connect terminals MSG and SD of one brake unit to the terminals MSG and SD of another brake unit. Incorrect wiring will cause damage to brake unit and resistor unit.**
  - **Do not remove the jumper across terminal P/+ and P1 except when connecting a DC reactor.**
- 
-

### 3.6 Connection Example with MT-BR5 Type Resistor

#### Unit MT-BR5

Make up a sequence which always shuts off power in the input side by an overheat signal of the built-in thermal relay of the resistor unit in case a built-in transistor of the brake unit is damaged and configure a circuit which prevents abnormal overheat of the discharging resistor leading to burnout. The external connection diagram is shown below.

#### 3.6.1 When connecting one inverter and one brake unit MT-BR5

(1) When connecting one resistor unit

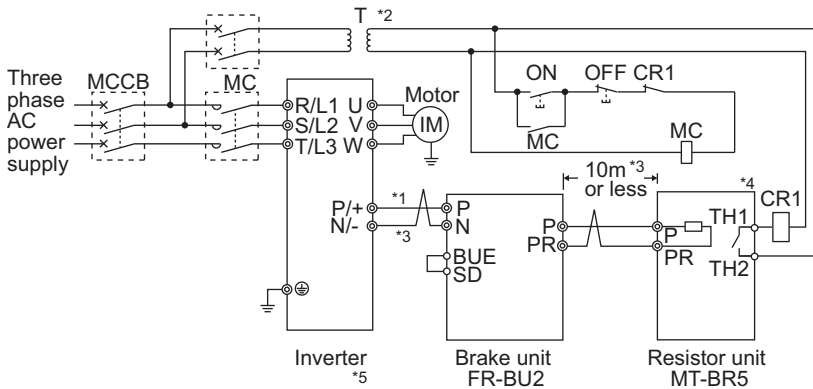

- \*1 Connect the inverter terminals (P/+, N/-) and brake unit (FR-BU2) terminals so that their terminal names match with each other. (Incorrect connection will damage the inverter and brake unit.)
- \*2 When the power supply is 400V class, install a stepdown transformer.
- \*3 The wiring distance between the inverter and brake unit (FR-BU2), and between brake unit (FR-BU2) and discharging resistor should be within 5m. If twisted wires are used, the distance should be within 10m. When twisting, twist at least 5 times per meter. The brake unit may be damaged if cables are not twisted when the wiring length is 5m or more or the wiring length exceeds 10m or more even if cables are twisted.
- \*4 The contact between TH1 and TH2 is open in the normal status and is closed at a fault.
- \*5 CN8 connector used with the MT-BU5 type brake unit is not used.

(2) When connecting several resistor units

Connect several resistor units (MT-BR5-H75K) to one brake unit (FR-BU2-H220K or H280K). (Connect 3 resistor units for H220K, and 4 resistor units for H280K.) Connect resistor units between terminal P and PR in parallel as shown in the below diagram.

<Example with FR-BU2-H220K>

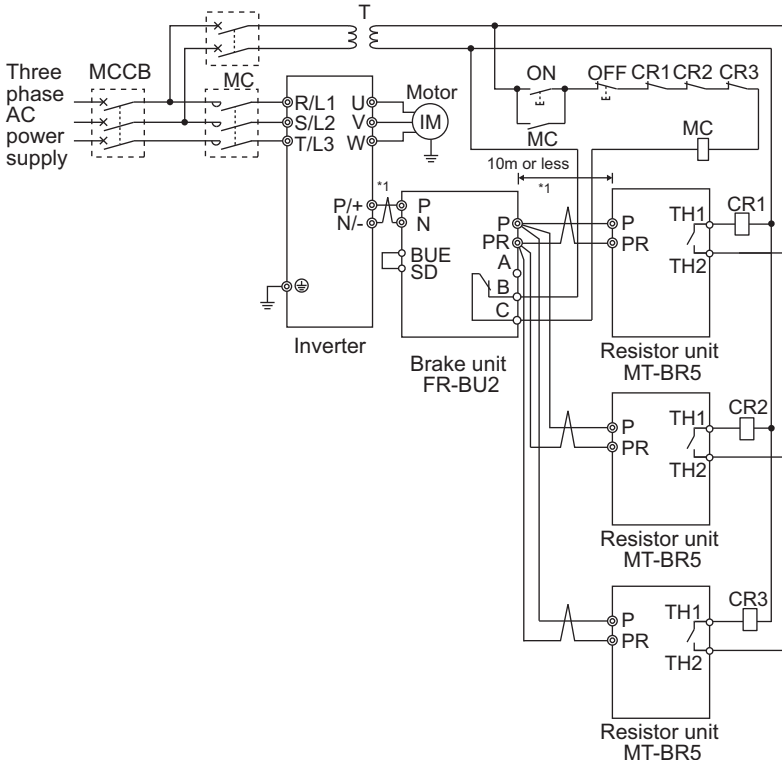

\*1 The wiring distance between the inverter and brake unit (FR-BU2), and between brake unit (FR-BU2) and discharging resistor should be within 5m. If twisted wires are used, the distance should be within 10m. When twisting, twist at least 5 times per meter. The brake unit may be damaged if cables are not twisted when the wiring length is 5m or more or the wiring length exceeds 10m or more even if cables are twisted.

**CAUTION**

- Set "2" in Pr. 0 Brake mode selection of the FR-BU2 to use MT-BR5 type resistor unit. (Refer to page 33.)
- Refer to the Instruction Manual of the inverter and set the parameters (Pr.30 and Pr.70) of the inverter correctly. (While the parameters are set correctly, the stall prevention (overvoltage), oL, does not occur.)
- Do not remove the jumper across terminal P/+ and P1 except when connecting a DC reactor.

### 3.6.2 When connecting several brake units to one inverter MT-BR5

When connecting several brake units to one inverter, always use terminals (MSG, SD) that are for the master/slave operation wiring.

Parallel operation by master ↔ slave operation (10 units maximum)

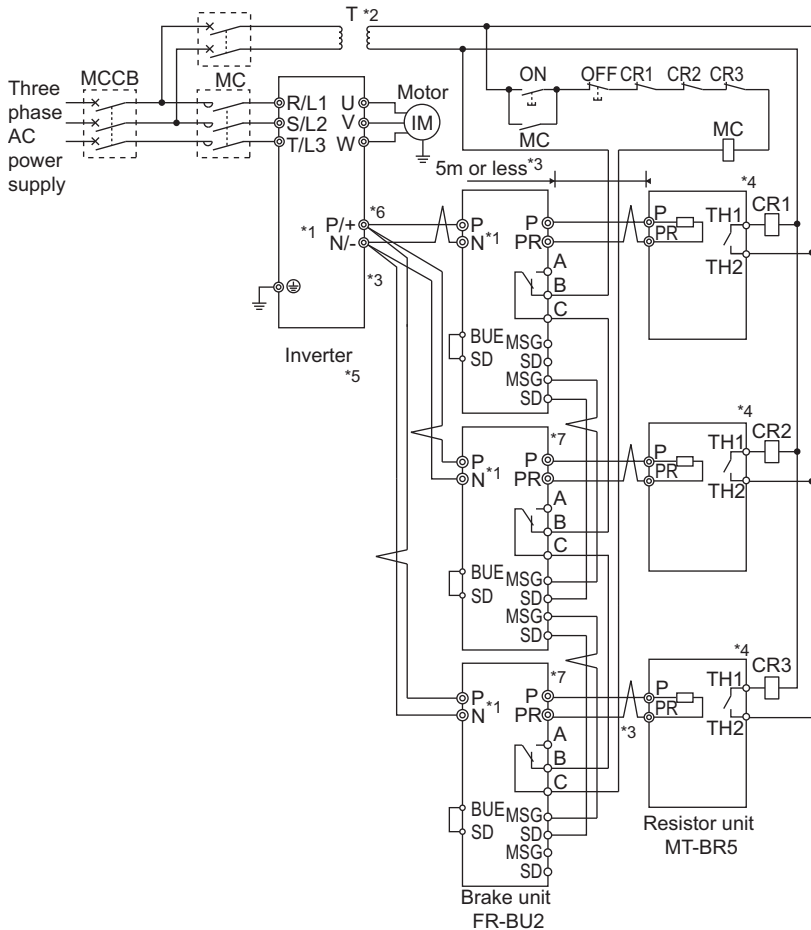



- \*1 Connect the inverter terminals (P/+, N/-) and brake unit (FR-BU2) terminals so that their terminal names match with each other. (Incorrect connection will damage the inverter and brake unit.)
- \*2 When the power supply is 400V class, install a stepdown transformer.
- \*3 The wiring distance between the inverter and brake unit (FR-BU2), and between brake unit (FR-BU2) and discharging resistor should be within 5m. Even when the wiring is twisted, the cable length must not exceed 10m. When twisting, twist at least 5 times per meter. The brake unit may be damaged if cables are not twisted when the wiring length is 5m or more or the wiring length exceeds 10m or more even if cables are twisted.
- \*4 The contact between TH1 and TH2 is open in the normal status and is closed at a fault.
- \*5 CN8 connector used with the MT-BU5 type brake unit is not used.
- \*6 When connecting several FR-BU2 to one inverter, connect P/+ of each FR-BU2 and of the inverter and N/- respectively. Do not pass wires from terminal P/+ and N/- of the FR-BU2 to terminals of other FR-BU2.  
When several peripheral devices are connected to the inverter and its terminals are fully used, set up a junction terminal block near terminals P/+ and N/- to connect a brake unit.
- \*7 The wiring length of the terminal MSG and SD should be 10m maximum. In addition, twist five times or more per 1m.

---

### CAUTION

---

- **Set "2" in Pr. 0 Brake mode selection of the FR-BU2 to use MT-BR5 type resistor unit.** (Refer to page 33.)
  - **Refer to the Instruction Manual of the inverter and set the parameters (Pr.30 and Pr.70) of the inverter correctly. (While the parameters are set correctly, the stall prevention (overvoltage), oL, does not occur.)**
  - **Do not operate the MT-BU5 type brake unit and FR-BU2 in parallel. Doing so could cause an alarm or brake unit failure. Use the FR-BU2 only when performing parallel operation.**
  - **When connecting several brake units to one inverter, always connect terminals MSG and SD of one brake unit to the terminals MSG and SD of another brake unit. Incorrect wiring will cause damage to brake unit and resistor unit.**
  - **Do not remove the jumper across terminal P/+ and P1 except when connecting a DC reactor.**
-

### 3.7 Wiring Instructions

- (1) When using this brake unit with the inverter that has terminal PX, be sure to remove the jumper across terminal PR and PX.  
(A failure to do so may damage a built-in brake resistor.)
- (2) Correctly connect the terminals P/+, N/- of the brake unit and terminals P, N of the inverter.

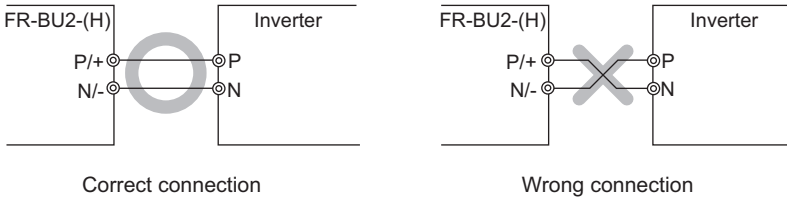

- (3) Minimize the cable length between the inverter and brake unit and the resistor unit and brake unit. In addition, twist five times or more per 1m. (Use a twisted cable when the wiring length exceeds 5m. Even when the wire is twisted, the cable length must not exceed 10m.)

The brake unit may be damaged if cables are not twisted when the wiring length is 5m or more or the wiring length exceeds 10m or more even if cables are twisted.

Use the wires of the above recommended size or larger (*refer to page 7*).

Twisting different color cables is recommended to prevent miswiring.

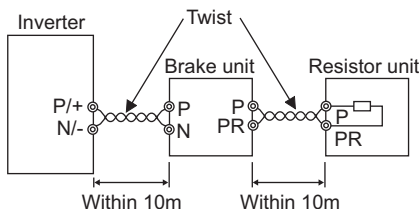

- (4) Do not allow wire offcuts to enter the unit, e.g. cover the vent hole at the top during wiring operation.

- (5) When connecting the power factor improving DC reactor, the FR-BU2 terminal P/+ must be connected to the inverter terminal P/+. Accidental connection to P1 terminal may damage the FR-BU2 and inverter.

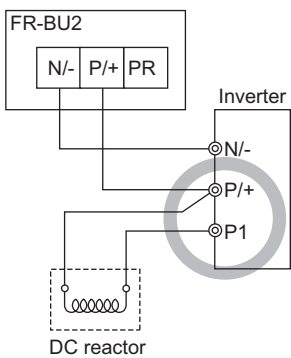

Correct connection

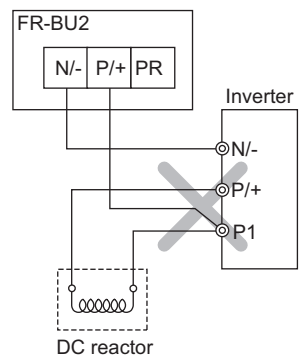

Wrong connection

- (6) When connecting several FR-BU2 to the inverter, be sure to connect terminal P/+, N/- of the FR-BU2 to terminal P/+, N/- of the inverter. Do not pass wires from terminal P/+ and N/- of the FR-BU2 to terminals of other brake unit.

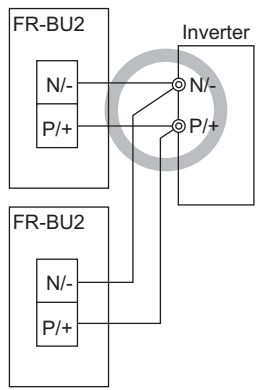

Correct connection

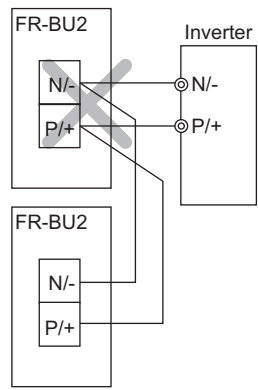

Wrong connection

# 4 OPERATION

## 4.1 Operation Panel

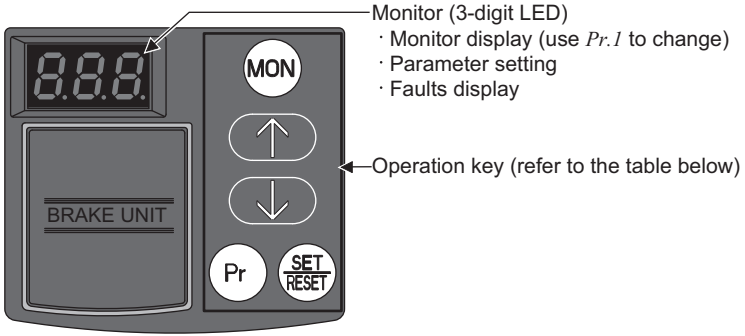

Key	Description
	Use this key to switch between the monitor display and faults history display.
 	Changes parameter number and setting value. Changes the faults history display.
	Switches to the parameter setting mode and a parameter setting screen appears.
	Use for parameter setting and fault reset.

## 4.2 Basic Operation

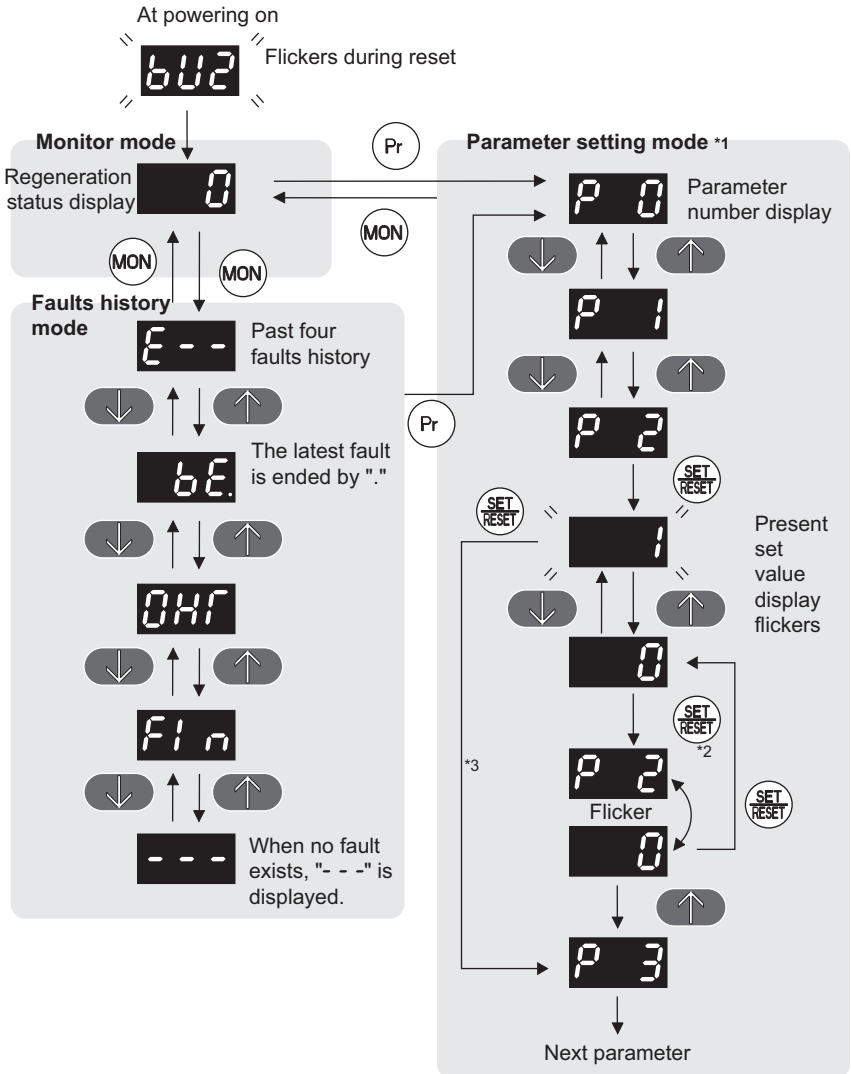

- \*1 Pressing (Pr) in the parameter setting mode displays parameter number.
- \*2 When the written value differs from the present set value, write is performed.
- \*3 When the written value is the same as the present set value, next parameter number is displayed.

### 4.3 Parameter List

Parameter	Name	Minimum Setting Increments	Initial Value	Setting Range	Reference Page	
0 <sup>*1</sup>	Brake mode selection	1	0	200V class, 75K or less in 400V class	0 to 2	33
				220K and 280K in 400V class	0, 2	
1	Monitor display data selection	1	0	0 to 5	34	
2 <sup>*1</sup>	Input terminal function selection 1 (RES)	1	0	0 to 3	36	
3 <sup>*1</sup>	Input terminal function selection 2 (BUE)	1	1			
77	Parameter write selection	1	0	0, 1	37	
78	Cumulative energization time carrying-over times	1	0	0 to 999 (reading only)	34	
90	Parameter for manufacturer setting. Do not set.					
91						
92						
93						
CLr	Parameter clear	1	0	0, 1	38	
ECL	Faults history clear	1	0	0, 1	39	
C1	Parameter for manufacturer setting. Do not set.					

\*1 Set this parameter only when the inverter is at a stop.

#### **CAUTION**

**To use the brake unit (FR-BU2), refer to the Instruction Manual of the inverter and set the parameters (Pr.30 and Pr.70) of the connected inverter correctly. Incorrect settings may disrupt normal operation.**

### 4.3.1 Brake mode selection (Pr.0)

Set *Pr. 0 Brake mode selection* by considering discharging resistor and resistor unit, which are used together.

Parameter Number	Name	Initial Value	Setting Range	Description
0	Brake mode selection	0	0	FR-BU2 mode
			1 *1	BU mode
			2 *2	MT-BU5 mode
			3	Manufacturer setting. Do not set.

\*1 Available with the FR-BU2-1.5K to 15K and FR-BU2-H7.5K to H30K only.

\*2 Available with the FR-BU2-55K, FR-BU2-H75K, H220K, and H280K only.

\*3 Perform the above parameter setting only when the inverter is at a stop.

#### (1) FR-BU2 mode (setting value "0" (initial value))

Use this mode when using in combination with FR-BR-(H) type resistor unit.

#### (2) BU mode (setting "1")

Use this mode when using in combination with GRZG type discharging resistor.

(Available with the FR-BU2-1.5K to 15K and FR-BU2-H7.5K to H30K only.)

#### (3) MT-BU5 mode (setting "2")

Use this mode when using in combination with MT-BR5 type brake unit.

(Available with the FR-BU2-55K, FR-BU2-H75K, H220K, and H280K only.)

### REMARKS

Refer to *page 14* for combination of the discharging resistor and resistor unit.

## 4.3.2 Multi-function monitor display (Pr.1, Pr.78)

Select the monitor to be displayed on the operation panel.

Parameter Number	Name	Initial Value	Setting Range	Description	Remarks
1	Monitor display data selection	0	0*	Regeneration status display	
			1	DC bus voltage (V)	
			2	DC bus voltage peak value (V)	
			3	Cumulative energization time (100h)	Energization time from shipment of the brake unit is accumulated every one hour. Time is not accumulated if power is turned OFF within one hour.
			4	Regenerative brake duty(%ED)(%)	During the FR-BU2 mode During the MT-BU5 mode (Pr.0 ="0, 2").
				Thermal heat (%)	During the BU mode (Pr.0 ="1").
5	Regenerative brake duty peak value (%)				
78	Cumulative energization time carrying-over times	0	0 to 999 (Reading only)	The numbers of cumulative energization time monitor exceeded 65535h is displayed. (Reading only)	

\* When Pr.1="0"(initial value), the first digit (far left) of the 3-digit LED display indicates regeneration status.

Two segments flicker (rotate) at a time during regeneration as shown below and rotate quickly when regeneration amount is large.

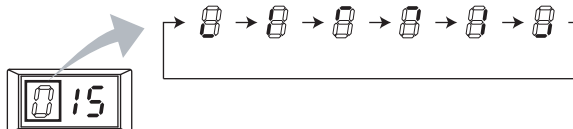



(1) Monitor description list (*Pr. 1*)

<i>Pr. 1</i> setting	Monitoring item	Increments	Description
0	Regeneration status display	1%	Indicates the ratio of brake unit operation during the specified time
1	DC bus voltage	1V	DC bus voltage is displayed.
2	DC current voltage peak value	1V	Holds the peak value of the DC bus voltage monitor ( <i>Pr. 1</i> = "1"). (clears at every inverter power on)
3	Cumulative energization time	100h	Accumulated energization time (power on time) after shipment of the brake unit is displayed. Energization time is stored in EEPROM every one hour. However, the displayed increments is 100h and "100h" is indicated as "1" and "200h" as "2". The value is cleared to 0h when the accumulated value exceeds 65535h and one count is added to <i>Pr. 78</i> . (up to "655" is displayed on the panel)
4	Regenerative brake duty (%ED)	0.1%	Heat amount presently accumulated is displayed in % as brake duty. A value less than 0.1% is rounded up to display. · FR-BU2 mode ( <i>Pr. 0</i> = "0" (initial value)) MT-BU5 mode ( <i>Pr. 0</i> = "2") If the brake duty exceeds 10%, regenerative brake is not operated. When the brake duty has fallen to or below 10%, brake operation starts.
	Cumulative heat value		· BU mode ( <i>Pr. 0</i> = "1") Thermal cumulative heat value is displayed. A value less than 0.1% is rounded up to display. (Thermal error ( <i>THE</i> ) is activated when the value reaches 100%.)
5	Regenerative brake duty peak value	0.1%	Holds the peak value of the regenerative brake duty (%ED) monitor ( <i>Pr. 1</i> = "4"). A value less than 0.1% is rounded up to display. Clamped at 100%. A peak value since power on is held and cleared at every reset. The amount of thermal heat peak value is displayed in the BU mode ( <i>Pr. 0</i> = "1"). Clamped at 100%.

(2) Cumulative energization time carrying-over time (*Pr. 1* = "3", *Pr. 78*)

Cumulative energization time monitor (*Pr. 1* = "3") accumulates energization time from shipment of the brake unit every one hour.

Time is not accumulated if power is turned off within one hour.

If the cumulative value exceeds 65535h (monitor display is up to "655"), it is added up from 0. Use *Pr. 78* to check the number of cumulative energization time monitor exceeded "655".

### 4.3.3 Input terminal function selection (Pr.2, Pr.3)

Use these parameters to select/change the input terminal functions.

Parameter Number	Name	Initial Value	Setting Range	Description
2	Input terminal function selection 1 (RES)	0	0 to 3	Refer to the following table
3	Input terminal function selection 2 (BUE)*1	1		

\*1 A jumper is connected across terminal BUE and SD in the initial setting.

\*2 Perform the above parameter setting only when the inverter is at a stop.

#### Relationship between the setting value and terminal function

Setting	Signal	Function	Description
0	RES*1	Brake unit reset	Used to reset the fault output provided when protective circuit is activated. Turn ON the RES signal for more than 0.1s, then turn it OFF. (Reset operation is made both at a normal operation and a fault.)
1	BUE*2	Brake operation permission signal	Input operation permission signal from outside. Turning OFF the signal shuts off power and turning ON the signal allows brake operation. Use this signal to allow or limit operation of the brake unit.
2	OHB	Brake resistor overheat (NC contact)	Input contact when using an external thermal relay to protect resistor from overheat, etc. Turning off the signal results in resistor overheat alarm (OHT). Available when the FR-BR is connected.
3	OHA	Brake resistor overheat (NO contact)	Input contact when using an external thermal relay to protect resistor from overheat, etc. Turning ON the signal results in resistor overheat alarm (OHT). Available when the MT-BR5 is connected.

\*1 Inputting this reset signal resets the internal cumulative heat value of the electronic thermal relay. Unnecessary resets or frequent resets may disable thermal protection of the discharging resistor and the resistor unit.

\*2 If BUE signal (brake operation enable) is not assigned, brake operation is always enabled.

#### 4.3.4 Parameter write disable selection (Pr. 77)

You can select whether write to various parameters can be performed or not. Use this function to prevent parameter values from being rewritten by misoperation.

Parameter Number	Name	Initial Value	Setting Range	Description
77	Parameter write selection	0	0	Parameter write is always enabled.
			1	Parameter write is not enabled.

##### (1) Disable parameter write (setting "1")

Parameter write is not enabled. (Read is enabled.)

Parameter clear cannot be performed, either.

## 4.3.5 Parameter clear

### POINT

**Set "1" in CLR All parameter clear to initialize all parameters. Parameters are not cleared when "1" is set in Pr. 77 Parameter write selection .**

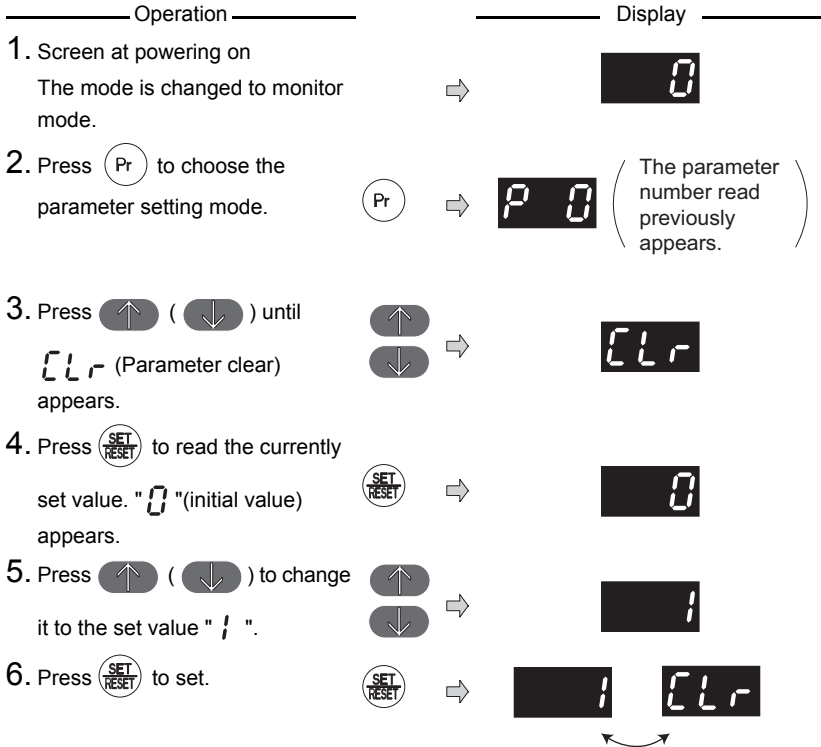

**Flicker...parameter clear complete!!**

- Press ( ) to read another parameter.
- Press to show the setting again.

### CAUTION

*Pr.78 Cumulative energization time carrying-over times is not cleared.*

### 4.3.6 Faults history clear

**POINT**

**Set "1" in *ECL* Faults history clear to clear faults history.**

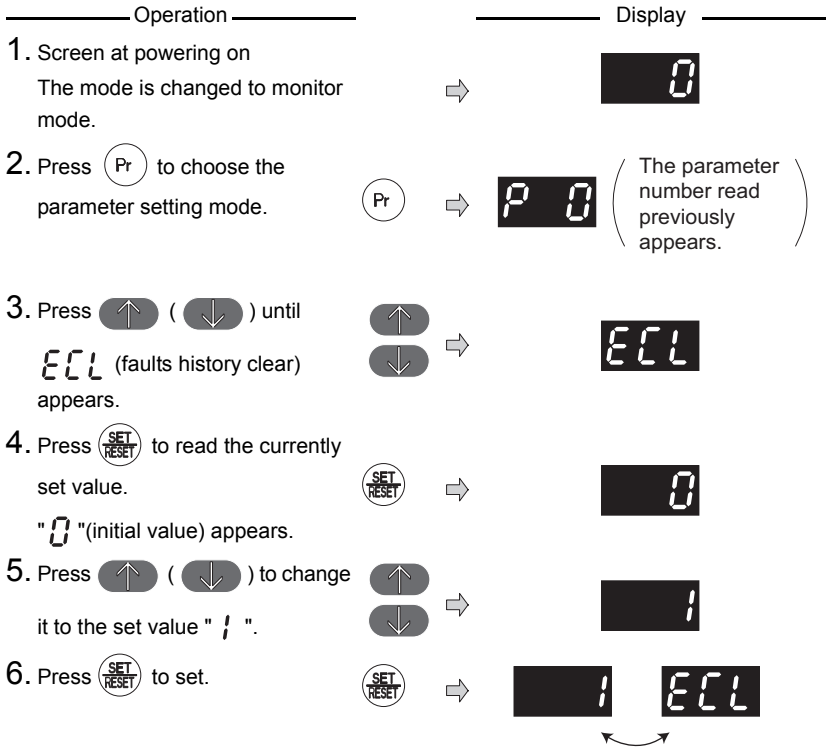

**Flicker...Faults history clear complete!!**

- Press (↑) (↓) to read another parameter.
- Press (SET/RESET) to show the setting again.

**REMARKS**

Refer to page 31 for checking faults history.

## 5 PROTECTIVE FUNCTIONS

### 5.1 Reset method of protective function

#### (1) Resetting the brake unit

The brake unit can be reset by performing any of the following operations.

The brake unit recovers about 1s after the reset is released

Operation 1 ... Using the operation panel, press  to reset the brake unit.

(This may only be performed when a fault occurs. (Refer to page 41 for faults.))

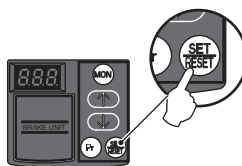

Operation 2 ... Switch OFF the inverter power once.

After the indicator of the FR-BU2 operation panel turns OFF, switch ON the inverter power again.

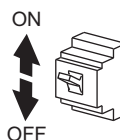

Operation 3 ... Turn ON the reset signal (RES) for more than 0.1s. (If the RES signal is kept ON, "Err" appears (flickers) to indicate that the brake unit is in a reset status.)

Brake unit

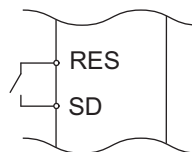

#### CAUTION

Resetting the inverter power (power ON again after the indicator on the FR-BU2 operation panel turns OFF) or inputting the reset signal resets the internal cumulative heat value of the electronic thermal relay to the initial value.

Avoid unnecessary resets and power resets.



## 5.2 Causes and Corrective Actions

### ●Error Message

A message regarding operational troubles is displayed. Output is not shutoff.

Operation panel indication	Er1	Er 1
Name	Write disable error	
Description	You attempted to make parameter setting when <i>Pr. 77 Parameter write selection</i> has been set to disable parameter write.	
Check point	Check the setting of <i>Pr. 77 Parameter write selection</i> . (Refer to page 37)	

Operation panel indication	Er2	Er 2
Name	Outside range error	
Description	When a value outside the parameter setting range is written	
Check point	Check the parameter setting value.	
Corrective action	Input a setting value within the parameter setting range.	

Operation panel indication	RB	r b
Name	Brake mode selection error	
Description	When <i>Pr.0 Brake mode selection</i> = "3 (manufacturer setting)," [ r b ] flickers and the regenerative operation is stopped.	
Check point	Check the <i>Pr. 0</i> setting.	
Corrective action	Set a value other than "3" in <i>Pr. 0</i> . (refer to page 33)	

### ●Fault

When the protective function is activated, the brake unit output is shut-off and a fault signal is output.

Operation panel indication	THE	THE
Name	Thermal error *1, *2	
Description	The electronic thermal relay function built in the brake unit detects discharging resistor overheat, and the protection circuit is activated to stop the brake operation when the temperature reaches the specified value.	
Check point	Check that the regeneration is not performed frequently.	
Corrective action	<ul style="list-style-type: none"> <li>· Reduce the regeneration load.</li> <li>· Use a larger-capacity brake unit with a larger-capacity discharging resistor.</li> </ul>	

\*1 This fault can be output only when *Pr. 0* is set to "1" (BU mode (when a GRZG type discharging resistor is connected)).

\*2 Resetting the brake unit initializes the internal cumulative heat value of the electronic thermal relay function.

Operation panel indication	FIN	Fin
Name	Fin overheat	
Description	If the heatsink overheats, the temperature sensor is actuated to stop the brake operation.	
Check point	<ul style="list-style-type: none"> <li>· Check for too high surrounding air temperature.</li> <li>· Check for heatsink clogging.</li> </ul>	
Corrective action	<ul style="list-style-type: none"> <li>· Set the surrounding air temperature to within the specifications.</li> <li>· Clean the heatsink.</li> </ul>	

Operation panel indication	BE	BE
Name	Brake transistor alarm detection	
Description	This function stops the inverter output if an alarm occurs in the brake circuit, e.g. damaged brake transistors. Brake operation also stops when the braking capability is not enough.	
Check point	<ul style="list-style-type: none"> <li>· Reduce the load inertia.</li> <li>· Check that the frequency of using the brake is proper.</li> <li>· Check for mis-wiring with the resistor (brake in the cable).</li> </ul>	
Corrective action	<ul style="list-style-type: none"> <li>· Immediately turn off the inverter power and check the wiring.</li> <li>· Change the brake unit if wiring is correct.</li> <li>· Use a larger-capacity brake unit with a larger-capacity discharging resistor or resistor unit.</li> </ul>	

Operation panel indication	OHT	OHT
Name	Resistor overheat alarm	
Description	When the external thermal relay provided for resistor overheat protection or the temperature relay, etc. switches on*, inputting the contacts in the brake unit stops brake operation.	
Check point	Check for resistor overheating.	
Corrective action	<ul style="list-style-type: none"> <li>· Reduce the load and frequency of operation.</li> <li>· Even if the relay contacts are reset automatically, the brake will not restart unless it is reset.</li> </ul>	

\* Operation can be selected using Pr.2 and Pr.3 (input terminal function selection). Set according to the resistor unit to be connected. (Refer to page 36)

Operation panel indication	PE	PE
Name	Parameter storage device alarm	
Description	Appears when an error occurred in the stored parameters. (EEPROM fault)	
Check point	Check for too many number of parameter write times.	
Corrective action	Please contact your sales representative.	





Operation panel indication	CPU	CPU
Name	CPU Fault	
Description	Appears during the built-in CPU and peripheral circuit errors occurred.	
Check point	Check for devices producing excess electrical noises around the brake unit.	
Corrective action	<ul style="list-style-type: none"> <li>· Take measures against noises if there are devices producing excess electrical noises around the brake unit.</li> <li>· Please contact your sales representative.</li> </ul>	

**CAUTION**

**If faults other than the above appear, contact your sales representative.**

### 5.3 Correspondence Between Digital and Actual Characters

There are the following correspondences between the actual alphanumeric characters and the digital characters displayed on the operation panel:

Actual	Indication	Actual	Indication	Actual	Indication
0	0	A	A	M	n
1	1	B	b	N	n
2	2	C	C	O	0
3	3	D	d	o	o
4	4	E	E	P	P
5	5	F	F	S	S
6	6	G	G	T	T
7	7	H	H	U	U
8	8	I	I	V	V
9	9	J	J	r	r
		L	L	-	-

# 6 SPECIFICATIONS

## 6.1 Brake Unit

Specifications	200V						400V						
Type FR-BU2-□	1.5K	3.7K	7.5K	15K	30K	55K	H7.5K	H15K	H30K	H55K	H75K	H220K	H280K
Applicable motor capacity	Capacity of the motor to be used with differs according to the braking torque and duty (%ED)												
Rated voltage	Maximum 400VDC						Maximum 800VDC						
Connected brake resistance	GRZG type, FR-BR type, MT-BR5 type											MT-BR5 type	
Multiple (parallel) operation	10 units maximum (Note that torque generated is not more than the tolerable overcurrent amount of connected inverter)												
Cooling system	Natural cooling												
Protective structure	IP00												
Approximate mass(kg)	0.9	0.9	0.9	0.9	1.4	2.0	0.9	0.9	1.4	2.0	2.0	13	13



## 6.2 Discharging Resistor/Resistor Unit

### (1) GZG, GRZG type

Resistor Unit Type		Discharging Resistor Total Resistance Value	Continuous Permissible Power
200V	GZG 300W-50 $\Omega$ (one)	50 $\Omega$	100W
	GRZG 200-10 $\Omega$ (three in series)	30 $\Omega$	300W
	GRZG 300-5 $\Omega$ (four in series)	20 $\Omega$	600W
	GRZG 400-2 $\Omega$ (six in series)	12 $\Omega$	1200W
400V	GRZG 200-10 $\Omega$ (six in series)	60 $\Omega$	600W
	GRZG 300-5 $\Omega$ (eight in series)	40 $\Omega$	1200W
	GRZG 400-2 $\Omega$ (twelve in series)	24 $\Omega$	2400W

### (2) FR-BR type

Resistor Unit Type		Discharging Resistor Total Resistance Value	Continuous Permissible Power
200V	FR-BR-15K	8 $\Omega$	990W
	FR-BR-30K	4 $\Omega$	1990W
	FR-BR-55K	2 $\Omega$	3910W
400V	FR-BR-H15K	32 $\Omega$	990W
	FR-BR-H30K	16 $\Omega$	1990W
	FR-BR-H55K	8 $\Omega$	3910W

### (3) MT-BR5 type

Resistor Unit Type		Discharging Resistor Total Resistance Value	Continuous Permissible Power
200V	MT-BR5-55K	2 $\Omega$	5500W
400V	MT-BR5-H75K	6.5 $\Omega$	7500W
	3 $\times$ MT-BR5-H75K *1	2.17 $\Omega$	22500W
	4 $\times$ MT-BR5-H75K *1	1.63 $\Omega$	30000W

\*1 When connected with FR-BU2-H220K

\*2 When connected with FR-BU2-H280K

## **7 PRECAUTIONS FOR MAINTENANCE AND INSPECTION**

---

The brake unit is a static unit mainly consisting of semiconductor devices. Daily inspection must be performed to prevent any fault from occurring due to the adverse effects of the operating environment, such as temperature, humidity, dust, dirt and vibration, changes in the parts with time, service life, and other factors.

### **7.1 Precautions for Maintenance and Inspection**

For some short time after the power is switched OFF, a high voltage remains in the smoothing capacitor. When accessing the brake unit for inspection, wait for at least 10 minutes after the power supply has been switched OFF, and then make sure that the voltage across the main circuit terminals P and N of the brake unit is not more than 30VDC using a tester, etc.

### **7.2 Inspection Item**

#### (1) Daily inspection

Basically, check for the following faults during operation.

- 1) Improper installation environment
- 2) Cooling system fault
- 3) Unusual vibration and noise
- 4) Unusual overheat and discoloration

#### (2) Cleaning

Always run the brake unit in a clean status.

When cleaning the brake unit, gently wipe dirty areas with a soft cloth immersed in neutral detergent or ethanol.

---

### **CAUTION**

---

**Do not use solvent, such as acetone, benzene, toluene and alcohol, as they will cause the brake unit surface paint to peel off.**

---



### **7.3 Periodic Inspection**

Check the areas inaccessible during operation and requiring periodic inspection. Consult us for periodic inspection.

- 1) Cooling system fault ..... Clean the air filter, etc.
- 2) Tightening check and retightening..... The screws and bolts may become loose due to vibration, temperature changes, etc. Check and tighten them.  
Tighten them according to the specified tightening torque.
- 3) Check the conductors and insulating materials for corrosion and damage.
- 4) Measure insulation resistance.
- 5) Check and replace the cooling fan, smoothing capacitor and relay.

**7.4 Daily and Periodic Inspection**

Area of Inspection	Inspection Item	Description	Interval		Corrective Action at Fault Occurrence	Customer's Check	
			Daily	Periodic *1			
General	Surrounding environment	Check the surrounding air temperature, humidity, dirt, corrosive gas, oil mist, etc.	<input type="radio"/>		Improve environment.		
	Overall unit	Check for unusual vibration and noise.	<input type="radio"/>		Check fault location and retighten.		
		Check for dirt, oil, and other foreign material. *2	<input type="radio"/>		Clean.		
Main circuit	General	(1)Check with megger (across main circuit terminals and earth (ground) terminal). (2)Check for loose screws and bolts. (3)Check for overheat traces on the parts. (4)Check for stain.		<input type="radio"/> <input type="radio"/> <input type="radio"/> <input type="radio"/>	Contact the manufacturer. Retighten. Contact the manufacturer. Clean.		
	Conductors, cables	Check cable sheaths for breakage and deterioration (crack, discoloration, etc.).		<input type="radio"/>	Contact the manufacturer.		
	Terminal block	Check for damage.		<input type="radio"/>	Stop the device and contact the manufacturer.		
	Resistor	(1)Check for crack in resistor insulation. (2) Check for unusual odor.		<input type="radio"/> <input type="radio"/>	Contact the manufacturer. Contact the manufacturer.		
Control circuit/protective circuit	Operation check	Check that no fault is found in protective and display circuits in a sequence protective operation test.		<input type="radio"/>	Contact the manufacturer.		
	Parts check	Overall	(1)Check for unusual odor and discoloration. (2)Check for serious rust development .		<input type="radio"/> <input type="radio"/>	Stop the device and contact the manufacturer. Contact the manufacturer.	
		Aluminum electrolytic capacitor	Check for liquid leakage in a capacitor and deformation trace.		<input type="radio"/>	Contact the manufacturer.	
Cooling system	Heatsink	(1)Check for clogging. (2)Check for stain.		<input type="radio"/> <input type="radio"/>	Clean. Clean.		
Indication	Indication	(1)Check that display is normal. (2)Check for stain.	<input type="radio"/>	<input type="radio"/> <input type="radio"/>	Contact the manufacturer. Clean.		



- \*1 One to two years of periodic inspection cycle is recommended. However, it differs according to the installation environment.  
Consult us for periodic inspection.
- \*2 Oil component of the heat dissipation grease used inside the brake unit may leak out. The oil component, however, is not flammable, corrosive, nor conductive and is not harmful to humans. Wipe off such oil component.

---

---

**CAUTION**

---

---

**Continuous use of a leaked, deformed, or degraded smoothing aluminum electrolytic capacitor (as shown in the table above) may lead to a burst, breakage or fire. Replace such a capacitor without delay.**

---

---

## 7.5 Replacement of Parts

The brake unit consists of many electronic parts such as semiconductor devices. The following parts may deteriorate with age because of their structures or physical characteristics, leading to reduced performance or fault of the brake unit. For preventive maintenance, the parts must be replaced periodically.

Part Name	Estimated lifespan *	Description
On-board smoothing capacitor	10 years	Replace the board (as required)
Relays	—	as required

\* Estimated lifespan for when the yearly average surrounding air temperature is 40°C. (without corrosive gas, flammable gas, oil mist, dust and dirt etc.)

### CAUTION

**For parts replacement, consult the nearest Mitsubishi FA Center.**

#### (1) Smoothing capacitors

An aluminum electrolytic capacitor is used for stabilizing the control power in the control circuit. The characteristics is deteriorated by the adverse effects of ripple currents, etc. The replacement intervals greatly vary with the surrounding air temperature and operating conditions. When the brake unit is operated in air-conditioned, normal environment conditions, replace the capacitors about every 10 years.

When a certain period of time has elapsed, the capacitors will deteriorate more rapidly. Check the capacitors at least every year (less than six months if the life will be expired soon).

The appearance criteria for inspection are as follows:

- 1) Case: Check the side and bottom faces for expansion.
- 2) Sealing plate: Check for remarkable warp and extreme crack.
- 3) Check for external crack, discoloration, liquid leakage, etc. Judge that the capacitor has reached its life when the measured capacitance of the capacitor reduced below 85% of the rating.

#### (2) Relays

To prevent a contact fault, etc., relays must be replaced according to the cumulative number of switching times (switching life).



## 8 SELECTION

### (1) Selection of Brake Unit

- 1) Select the brake unit according to the motor capacity.
- 2) To obtain the braking torque of 200% or more, use a larger inverter in capacity.

### CAUTION

**The regenerative operation requires a large braking torque. Frequent use of the regenerative operation may shorten the life of the brake unit. For frequent use, increase the capacity of the brake unit, or use multiple brake units.**

<GZG, GRZG type are connected>

Power Supply Voltage	Braking Torque	Motor (kW)							
		0.4	0.75	1.5	2.2	3.7	5.5	7.5	
200V class	50%30s	FR-BU2-1.5K			FR-BU2-3.7K		FR-BU2-7.5K		
	100%30s	FR-BU2-1.5K	FR-BU2-3.7K	FR-BU2-7.5K		FR-BU2-15K			
400V class	50%30s	- <sup>2</sup>			FR-BU2-H7.5K				
	100%30s	- <sup>2</sup>			FR-BU2-H7.5K		FR-BU2-H15K		

Power supply voltage	Braking Torque	Motor (kW)							
		11	15	18.5	22	30	37	45	55
200V class	50%30s	FR-BU2-15K	2×FR-BU2-15K <sup>*1</sup>			3×FR-BU2-15K <sup>*1</sup>		4×FR-BU2-15K <sup>*1</sup>	
	100%30s	2×FR-BU2-15K <sup>*1</sup>	3×FR-BU2-15K <sup>*1</sup>	4×FR-BU2-15K <sup>*1</sup>	5×FR-BU2-15K <sup>*1</sup>	6×FR-BU2-15K <sup>*1</sup>	7×FR-BU2-15K <sup>*1</sup>		
400V class	50%30s	FR-BU2-H15K	FR-BU2-H30K			2×FR-BU2-H30K <sup>*1</sup>			
	100%30s	FR-BU2-H30K	2×FR-BU2-H30K <sup>*1</sup>			3×FR-BU2-H30K <sup>*1</sup>		4×FR-BU2-H30K <sup>*1</sup>	

\*1 The number before the model name indicates the number of connectable units in parallel. (Refer to page 19)

\*2 The inverter of 1.5K or less of 400V class can not be used in combination with a brake unit. To use in combination with a brake unit, use the inverter of 2.2K or more.

<When FR-BR is connected>

●%ED at short-time rating when braking torque is 100%

Motor Capacity		5.5 kW	7.5 kW	11 kW	15k W	18.5 kW	22 kW	30 kW	37 kW	45 kW	55 kW
200V	FR-BU2-15K	80	40	15	10	—	—	—	—	—	—
	FR-BU2-30K	—	—	65	30	25	15	10	—	—	—
	FR-BU2-55K	—	—	—	—	90	60	30	20	15	10
400V	FR-BU2-H15K	80	40	15	10	—	—	—	—	—	—
	FR-BU2-H30K	—	—	65	30	25	15	10	—	—	—
	FR-BU2-H55K	—	—	—	—	90	60	30	20	15	10

●Braking torque (%) at short-time rating of 15s

Motor Capacity		5.5 kW	7.5 kW	11 kW	15 kW	18.5 kW	22 kW	30 kW	37 kW	45 kW	55 kW
200V	FR-BU2-15K	280	200	120	100	80	70	—	—	—	—
	FR-BU2-30K	—	—	260	180	160	130	100	80	70	—
	FR-BU2-55K	—	—	—	—	300	250	180	150	120	100
400V	FR-BU2-H15K	280	200	120	100	80	70	—	—	—	—
	FR-BU2-H30K	—	—	260	180	160	130	100	80	70	—
	FR-BU2-H55K	—	—	—	—	300	250	180	150	120	100

$$\text{Regeneration duty factor (operation frequency)\%ED} = \frac{t_b}{t_c} \times 100 \quad t_b < 15\text{s (continuous operation time)}$$

Example 1 Travel operation

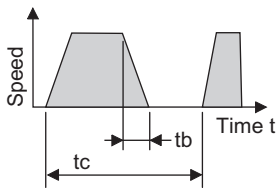

Example 2 Lift operation

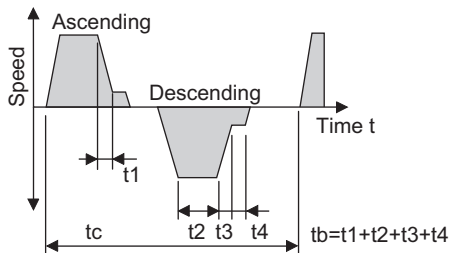

\* Do not use with a conventional BU type brake unit.

<MT-BR5 is connected>

● ED at short-time rating when braking torque is 100%

Motor Capacity Number of brake unit connected *1		Motor Capacity										
		75 kW	90 kW	110 kW	132 kW	160 kW	185 kW	220 kW	250 kW	280 kW	315 kW	355 kW
200V class FR-BU2-55K	1	5	—	—	—	—	—	—	—	—	—	—
	2	20	15	10	—	—	—	—	—	—	—	—
400V class FR-BU2-H75K	1	10	5	—	—	—	—	—	—	—	—	—
	2	40	25	20	10	5	5	—	—	—	—	—
400V class FR-BU2-H220K	1	80	60	40	25	15	10	10	5	—	—	—
	2	—	—	—	—	—	—	20	20	15	15	15
400V class FR-BU2-H280K	1	—	80	65	40	30	20	15	10	10	10	5
	2	—	—	—	—	—	—	—	—	—	20	20

Motor Capacity Number of brake unit connected *1		Motor Capacity				
		375 kW	400 kW	450 kW	500 kW	560 kW
400V class FR-BU2-H75K	1	—	—	—	—	—
	2	—	—	—	—	—
400V class FR-BU2-H220K	1	—	—	—	—	—
	2	10	10	10	5	—
400V class FR-BU2-H280K	1	—	—	—	—	—
	2	15	15	15	10	10

- \*1 The number next to the model name indicates the number of connectable units in parallel.  
(Refer to page 26)
- \*2 To obtain a large braking torque, the motor has to have a torque characteristic that meets the braking torque.  
Check the torque characteristic of the motor.

● Braking torque (%) at short-time rating of 15s

Motor Capacity Number of brake unit connected *1		Motor Capacity										
		75 kW	90 kW	110 kW	132 kW	160 kW	185 kW	220 kW	250 kW	280 kW	315 kW	355 kW
200V class FR-BU2-55K	1	70	60	50	—	—	—	—	—	—	—	—
	2	150	120	100	—	—	—	—	—	—	—	—
400V class FR-BU2-H75K	1	100	80	70	55	45	40	35	—	25	—	—
	2	150	150	135	110	90	80	70	60	50	45	40
400V class FR-BU2-H220K	1	—	—	150	150	135	115	100	80	55	—	—
	2	—	—	—	—	—	—	—	—	150	150	140
400V class FR-BU2-H280K	1	—	—	—	—	150	150	150	125	100	70	—
	2	—	—	—	—	—	—	—	—	—	—	—

Motor Capacity Number of brake unit connected *1		Motor Capacity				
		375 kW	400 kW	450 kW	500 kW	560 kW
400V class FR-BU2-H75K	1	20	—	—	—	—
	2	40	—	—	—	—
400V class FR-BU2-H220K	1	—	—	—	—	—
	2	120	110	100	90	80
400V class FR-BU2-H280K	1	—	—	—	—	—
	2	150	150	130	115	100

\*1 The number next to the model name indicates the number of connectable units in parallel.  
(Refer to page 26)

\*2 To obtain a large braking torque, the motor has to have a torque characteristic that meets the braking torque.  
Check the torque characteristic of the motor.



# 9 OUTLINE DIMENSION DRAWINGS

## (1) Brake Unit

FR-BU2-1.5K to 15K

FR-BU2-H7.5K, H15K

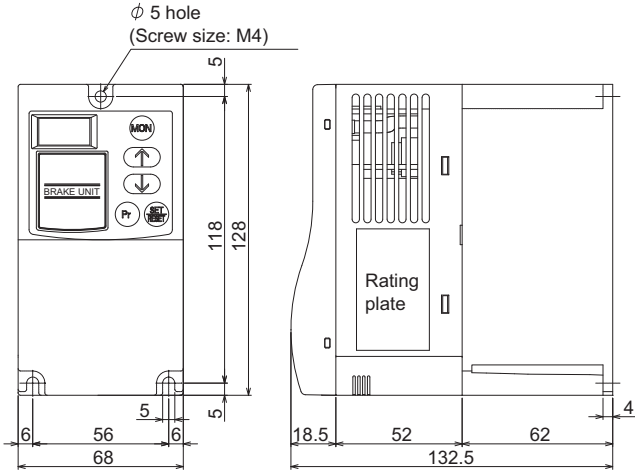

(Unit: mm)

FR-BU2-30K

FR-BU2-H30K

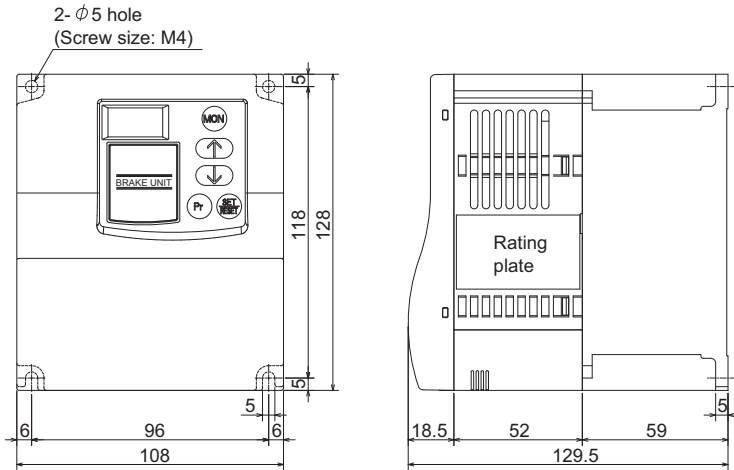

(Unit: mm)

FR-BU2-55K

FR-BU2-H55K, H75K

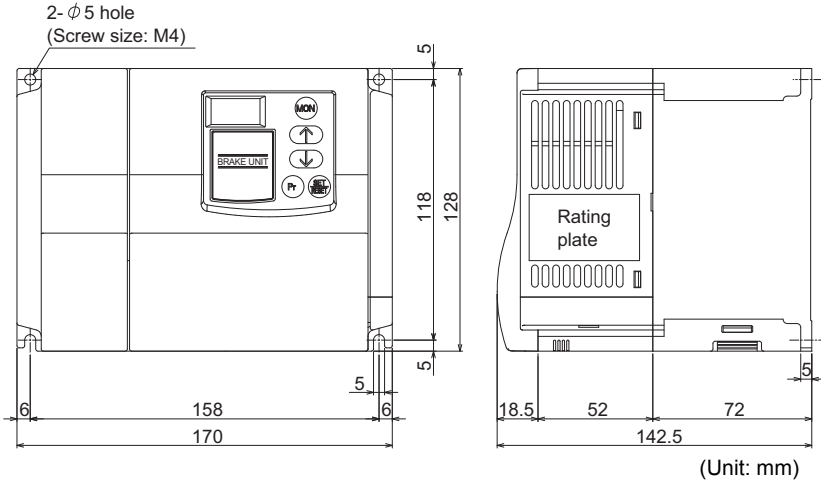

FR-BU2-H220K, H280K

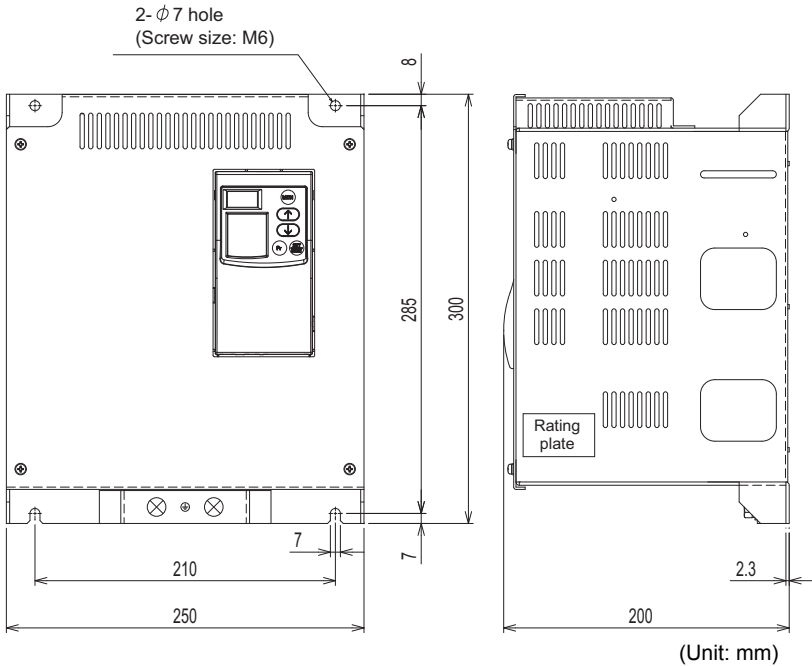



(2) Resistor unit

<GRZG type>

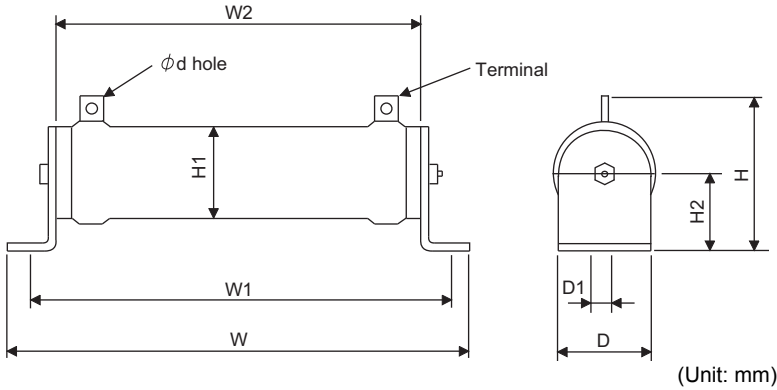

Model	W	W1	W2	H	H1	H2	D	D1	d
GZG300W	335	309	274	78	42	40	40	9.5	5.5
GRZG200	306	287	266	53	33	22	26	6	5.5
GRZG300	334	309	274	79	47	40	40	9.5	5.5
GRZG400	411	385	350	79	47	40	40	9.5	5.5

The temperature of discharging resistors could be above 200°C if FR-BU2 is used continuously. For wiring, therefore, use heat-resistant wires (such as fiber-glass braided wires) or cover the wires with silicone tube. Also perform wiring so that the wires do not make contact with the resistors.

Also, separate a component, which is low in heat-resistant property, at least 15 to 20cm from the resistors.

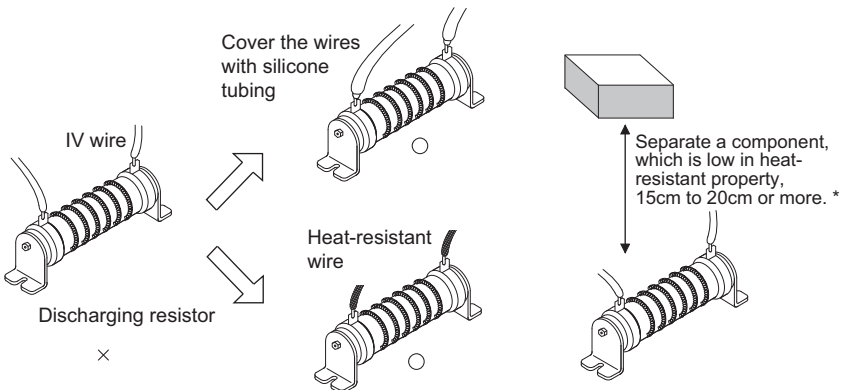

\* When it is inevitable to place a component, which is low in the heat-resisting property, in the vicinity of the resistors, mount a temperature sensor to the component with low heat-resisting property and make up a sequence which shuts off power of the inverter input side by the temperature sensor signal. For the temperature sensor, contact the manufacturer.

## <FR-BR type>

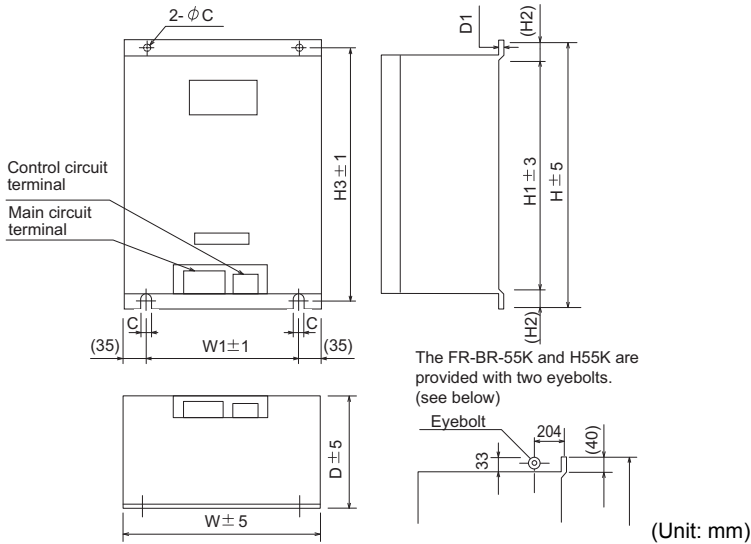

Resistor Unit Type		W	W1	H	H1	H2	H3	D	D1	C	Approximate Mass (kg)
200V	FR-BR-15K	170	100	450	410	20	432	220	3.2	6	15
	FR-BR-30K	340	270	600	560	20	582	220	4	10	30
	FR-BR-55K	480	410	700	620	40	670	450	3.2	12	70
400V	FR-BR-H15K	170	100	450	410	20	432	220	3.2	6	15
	FR-BR-H30K	340	270	600	560	20	582	220	4	10	30
	FR-BR-H55K	480	410	700	620	40	670	450	3.2	12	70

- \*1 Ventilating openings are provided on both left and right side surfaces and on the top surface. The bottom side is open.
- \*2 The temperature of resistor unit could be above 100°C if FR-BU2 is used continuously. Perform wiring so that the wires do not make contact with the resistors. For wiring, therefore, use heat-resistant wires (such as fiber-glass braided wires) or cover the wires with silicone tube.
- \*3 The temperature of the resistor unit abnormally increases if the brake unit is operated exceeding the specified duty. If the brake unit is left in such condition, it may even result in overheat of the resistor unit. Switch OFF the inverter with a thermostat (NC contact) provided as an overheat protection to avoid this.
- \*4 The resistor unit is provided with a thermostat (NC contact) as overheat protection. If the thermostat operates in normal operation, check *Pr.0 Brake mode selection* setting.
- \*5 Always install resistor unit on vertical surface in the vertical direction. Installing it in the horizontal direction or on a horizontal surface reduces the heat dissipation effect, and a thermostat for overheat protection may operate.

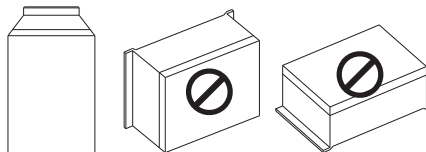





<MT-BR5 type>

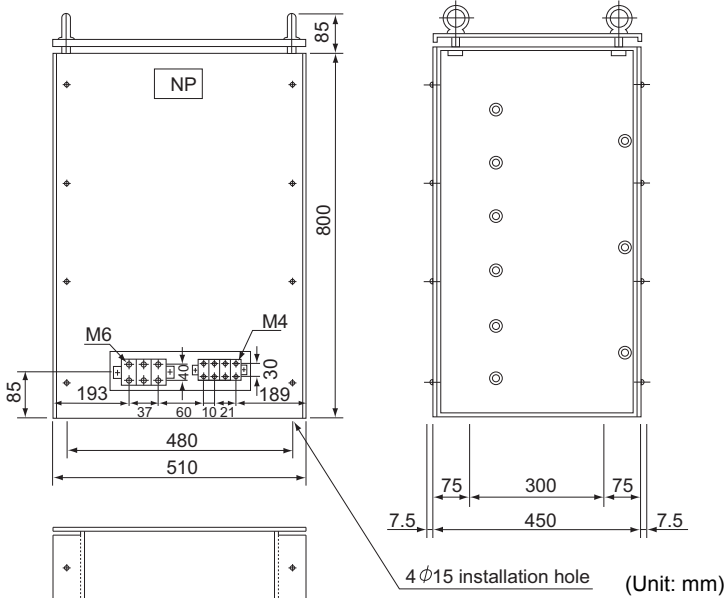

Resistor Unit Type		Resistance Value	Approximate Mass (kg)
200V class	MT-BR5-55K	2.0 $\Omega$	70
400V class	MT-BR5-H75K	6.5 $\Omega$	65

- \*1 Be sure to select the well-ventilated place for installation of the resistor unit. Ventilation is necessary when installing the resistor in a place, e.g. enclosure, where heat is not well diffused.
- \*2 The temperature of resistor unit could be above 300°C if FR-BU2 is used continuously. Therefore, wire the cable so as not to touch the resistor. Also, separate a component, which is low in heat-resistant property, at least 40 to 50cm from the resistors.
- \*3 The temperature of the resistor unit abnormally increases if the brake unit is operated exceeding the specified duty. Since the resistor unit may result in overheat if the temperature of the brake unit is left unchanged, switch OFF the inverter with a thermostat (NO contact) provided as a overheat protection.
- \*4 The resistor unit is provided with a thermostat (NO contact) as overheat protection. If the thermostat operates in normal operation, check *Pr. 0 Brake mode selection* setting.
- \*5 Always install resistor unit on vertical surface in the vertical direction. Installing it in the horizontal direction or on a horizontal surface reduces the heat dissipation effect, and a thermostat for overheat protection may operate.

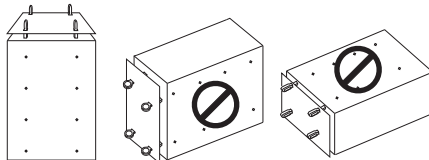

# 10 INSTRUCTIONS FOR COMPLIANCE WITH THE EU DIRECTIVES (400V CLASS ONLY)

---

The EU Directives are issued to standardize different national regulations of the EU Member States and to facilitate free movement of the equipment, whose safety is ensured, in the EU territory.

Since 1996, compliance with the EMC Directive that is one of the EU Directives has been legally required. Since 1997, compliance with the Low Voltage Directive, another EU Directive, has been also legally required. When a manufacturer confirms its equipment to be compliant with the EMC Directive and the Low Voltage Directive, the manufacturer must declare the conformity and affix the CE marking.

## ● The authorized representative in the EU

The authorized representative in the EU is shown below.

Name: Mitsubishi Electric Europe B.V.

Address: Gothaer strasse 8, 40880 Ratingen, Germany

## (1) EMC Directive

### 1) Our view of brake unit for the EMC Directive

This brake unit is a component designed for installation in an enclosure and for use with the inverter to control other equipment/device.

Therefore, we understand that the brake unit are not covered directly by the EMC Directive. However, the EMC Directive applies to machines/equipment which has the brake unit being installed, and these machines and equipment must carry the CE marks.

### 2) Note

\* Install a motor, the EMC Directive compliant EMC filter, and a control cable according to the instructions written in the EMC Installation Guidelines (BCN-A21041-204).

\* Confirm that the integrated system installing the brake unit complies with EMC Directive.

## (2) Low Voltage Directive

We have self-confirmed our brake units (400V class only) as products compliant to the Low Voltage Directive (Conforming standard EN 61800-5-1) and place the CE mark on the brake units.



1) Abstract of precautions

- \* Do not use an earth leakage circuit breaker as an electric shock protector without connecting the equipment to the earth. Connect the equipment to the earth securely.
- \* Wire the earth (ground) terminal independently. (Do not connect two or more cables to one terminal.)
- \* Use the earth (ground) cable and the cable sizes on *page 7* under the following conditions.
  - Surrounding air temperature : 40°C or less
 If conditions are different from above, select PVC cable according to EN60204 ANNEX C TABLE 5.
- \* Use a tinned (plating should not include zinc) crimping terminal to connect the earth (ground) cable. When tightening the screw, be careful not to damage the threads.  
 For using as a product compliant with the Low Voltage Directive, use the cable indicated in *page 7*.
- \* Use the moulded case circuit breaker and magnetic contactor which conform to the EN or IEC Standard.
- \* When using an earth leakage current breaker, use a residual current operated protective device (RCD) of type B (breaker which can detect both AC and DC). When not using the earth leakage current breaker, provide double or reinforced insulation between the brake unit and other equipment, or put a transformer between the main power supply and inverter.
- \* Use the inverter under the condition of overvoltage category II (usable regardless of the earth (ground) condition of the power supply), overvoltage category III (usable with the earthed-neutral system power supply) specified in IEC60664.
  - To use the inverter under the conditions of pollution degree 3, install it in the enclosure of IP54 or higher.
- \* On the input and output of the brake unit, use cables of the type and size set forth in EN60204 Appendix C.
- \* The operating capacity of the relay outputs (terminal symbols A, B, C) should be 30VDC, 0.3A. (Relay output has basic isolation from the brake unit internal circuit.)
- \* Control circuit terminals, which is written on *page 5* of the brake unit Instruction Manual, are safely isolated from the main circuit.
- \* Environment

	Running	In Storage	During Transportation
Surrounding air temperature	-10°C to +50°C	-20°C to +65°C	-20°C to +65°C
Humidity	90% RH or less	90% RH or less	90% RH or less
Maximum altitude	1000m	1000m	10000m

Details are given in the technical information "Low Voltage Directive Conformance Guide" (BCN-A21041-203). Please contact your sales representative.

# 11 INSTRUCTIONS FOR UL, cUL COMPLIANCE

---

## Instructions for UL, cUL compliance (UL mark is printed on UL Listed products)

### 1. UL standard

UL standard is the general standard of motor control devices in the United States. Safety standard for devices, equipments, materials are established to protect human life and property from fire, electric shock, and other accidents. The FR-BU2 is considered as part of power converter and subject to UL508C (Power Conversion Equipment) .

### 2. Necessity of UL qualification

Laws in the U.S.A. are divided into federal laws and municipal laws of states and cities. The federal government stipulates minimum regulations only and local governments set specific rules. UL standard is not therefore enforced by a federal law. However, some local governments specify the necessity of product safety certification by the UL or other testing agency and even some local governments without regulations require that products should satisfy minimum standard which meets "safety products" set by a federal law.

### 3. Instructions

#### (1) Wiring the brake unit with the inverter and resistor unit

Use the UL listed copper stranded wire (rated at 75°C) for wiring between inverter and brake unit, and between brake unit and resistor unit. When wiring to the terminals (N/-, P/+, PR), *refer to page 7*, and use the UL listed crimp ring terminal.

Crimp the crimping terminals with the crimping tool recommended by the terminal maker.

#### (2) Brake duty

Maximum permissible regenerative brake duty is as follows.

Models	Maximum percent E.D.
FR-BU2 Series Brake unit	10
MT-BR5-H75K	8
GZG, GRZG Series resistor	10

#### (3) Both brake unit and resistor unit are an open type device which must be installed inside a separate and suitable Type 1 enclosure.

#### (4) Secure the resistor unit (MT-BR5 type) to the bottom surface of the Type 1 enclosure using the mounting holes of the unit to prevent movement.



- (5) Make the necessary wiring connections in accordance with the NEC for installations in North America, CEC for Canada and any applicable local codes.
- (6) Due to Type 1 enclosure variables of size, cooling fans, ventilation and location, be sure to monitor the surrounding air temperature of the Type 1 enclosure to not exceed 50°C.  
Install additional cooling fan as required.
- (7) Maximum Surrounding Air Temperature inside the enclosure must be maintained at no higher than 50°C.

## REVISIONS

\*The manual number is given on the bottom left of the back cover.

Print Date	*Manual Number	Revision
Sep. 2006	IB(NA)-0600292ENG-A	First edition
Nov. 2008	IB(NA)-0600292ENG-B	<div style="border: 1px solid black; padding: 2px; display: inline-block;">Addition</div> Instructions for UL, cUL compliance When used in combination with MT-BR5
Mar. 2010	IB(NA)-0600292ENG-C	<div style="border: 1px solid black; padding: 2px; display: inline-block;">Addition</div> <ul style="list-style-type: none"> <li>· FR-BU-H220K, H280K</li> <li>· Instructions for compliance with the EU Directives (400V class only)</li> </ul>
Aug. 2014	IB(NA)-0600292ENG-D	<div style="border: 1px solid black; padding: 2px; display: inline-block;">Modification</div> <ul style="list-style-type: none"> <li>· Safety Instructions</li> </ul>

