

TS8000



Cable
Diagrams
HA471054U002

TS8000 HMI Cable Diagrams

RS-232 To 590+, 631, 637F, 650v, 690+, 890, Link (CM471054)

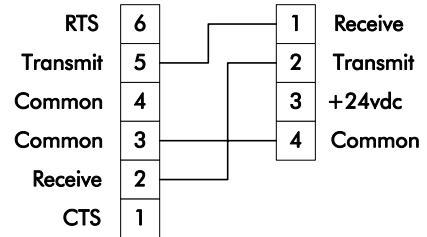
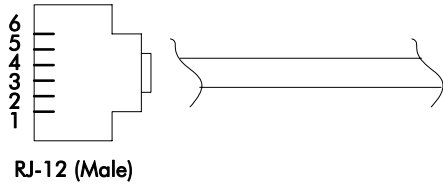

RS-232 To Serial PC, PLC

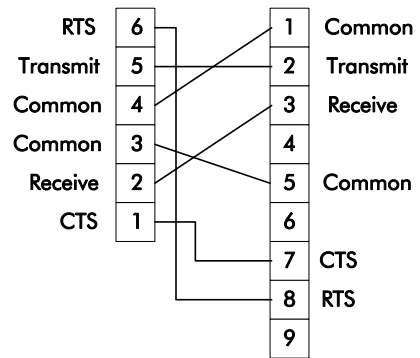
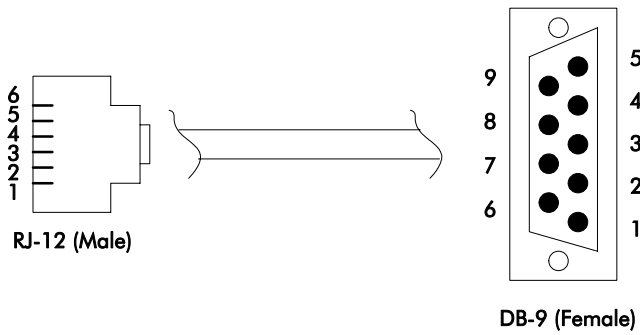

TS8000 HMI Cable Diagrams

RS-485 (2-Wire) To 6053/6055 Techbox

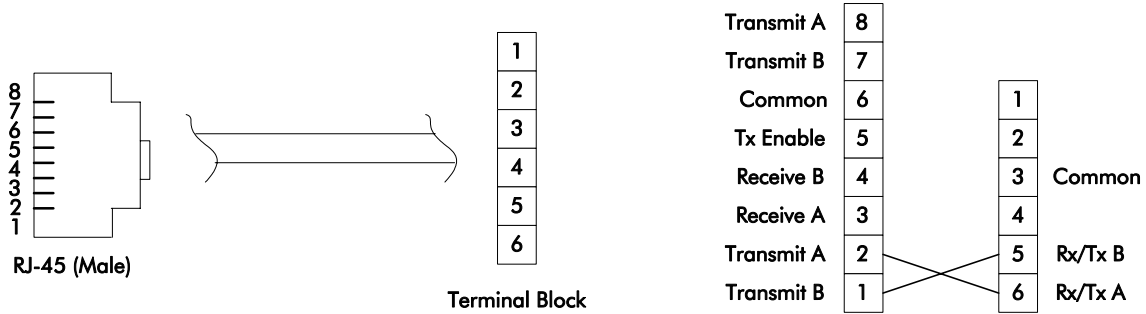

RS-485 (4-Wire) To 6053/6055 Techbox

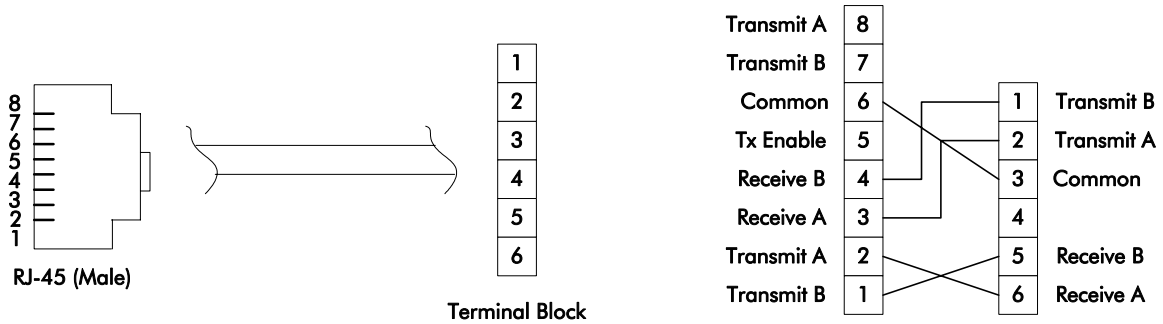

RS-485 (4-Wire) To 6053/6055 Techbox (Multidrop)

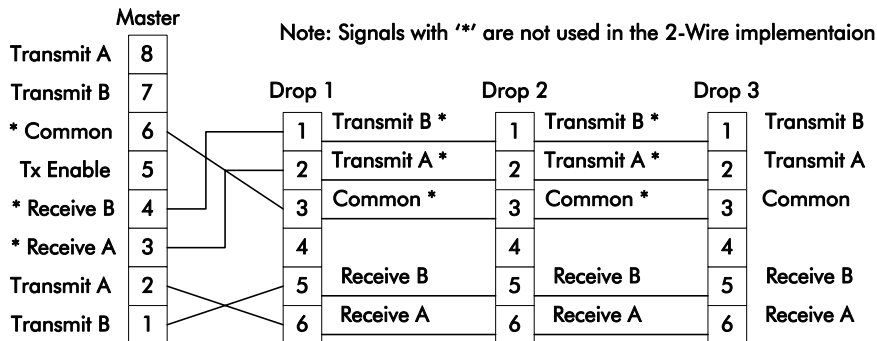

TS8000 HMI Cable Diagrams

RS-232 To 635, 637 Servo

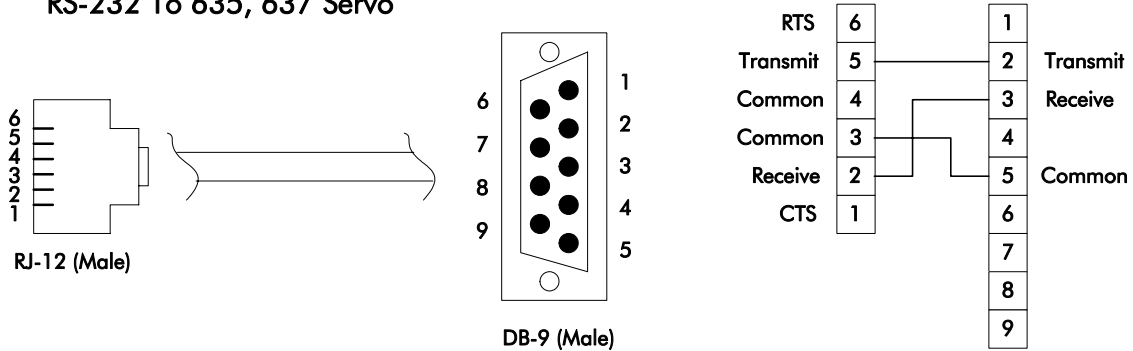

RS-485 (4-Wire) To 635, 637 Servo

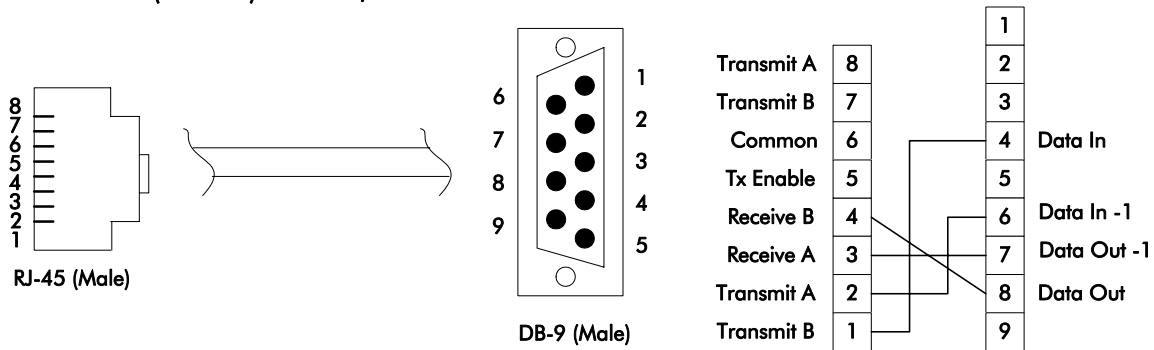

RS-485 (4-Wire) To 635, 637 Servo (Multidrop)

