

RE.0444N - Normal

Direct Current Tachometer generator



Applications : Industry
Speed control & regulation

Descriptions : High quality signal
Cable connection
Various mechanical & electrical options



MOUNTING FORMS

Flange mounting – B5

	Shaft diameter	1 commutator	2 commutators
A	Ø 7 mm	126 mm	142 mm
	Ø 11 mm	131 mm	
	Ø 14 mm	128 mm	
B	Ø 7 mm	132 mm	148 mm
	Ø 11 mm	137 mm	
	Ø 14 mm	141 mm	
C	Ø 7 mm	14,5 mm	30 mm
	Ø 11 mm	17,5 mm	
	Ø 14 mm	21,5 mm	

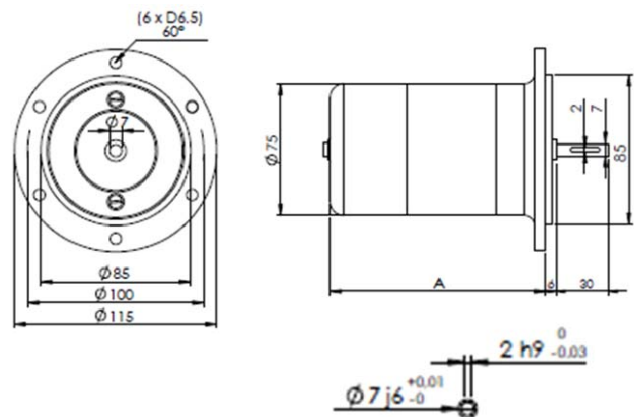

Base mounting – B3

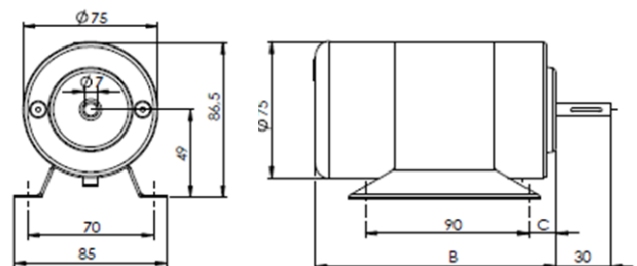

MAIN CHARACTERISTICS

CONSTRUCTION DETAILS

Number of poles	2
Armature slots number	19
Commutator blades number	57
Insulation class	B (IEC 34-1)
Operating temperature	-30 +130 °C
Climatic protection	C _a (IEC 68-1)
Ingress protection	IP44 (IEC 34-5) IP55 with sealing cover
Direction of rotation	reversible
Excitation	Permanent magnets - Alnico

Net weight	1,8 kg (1 commutator) 2,1 kg (2 commutators)
------------	---



RE.0444N - Normal

Direct Current Tachometer generator

DESCRIPTION	SYMB	VALUE	DESCRIPTION	SYMB	VALUE
Max. speed	n_m	12 000 rpm	Slots harmonics (f=Z.n.)	E_z	$\leq 0,3 \% E_c$
Moment of inertia	J	0,95 Kg cm ²	Calibration precision	E_o	$\pm 1 \% E_{T_0}$
No-load driving torque	Mr	1,5 N.cm	E.M.F. temperature drift		
Max. radial shaft stress			Not compensated	E_c	0,02 %/°C
7x30 mm	F	0,4 da N	Compensated	E_c	0,005 %/°C
11x30 mm	F	1,0 da N	Time constant	C_t	2,5 ms
Maximum E.M.F.	E_m	600 V	Filter :		
Maximum linearity error	E	$\leq 0,15 \% E_T$	Time constant of filter		0,47 ms
Overall ripple rate (peak to peak)	E_c	$\leq 0,5 \% E_c$	Load current	L_c	5 mA
Rotation harmonics (f=2 p.n)	E_p	$< 0,2 \% E_c$	Speed	n	3000 rpm

MECHANICAL OPTIONS

	MOUNTING SIDE			OPPOSITE MOUNTING SIDE (upon request)		
	D (mm)	L (mm)	Ball-bearing	D (mm)	L (mm)	Ball-bearing
Standard shaft	7	30	8 x 22 x 7 ZZ	7	30	8 x 22 x 7 ZZ
Special shaft	11	30	12 x 28 x 8 ZZ			
	14 max	30	15 x 32 x 9 ZZ	8	30	8 x 22 x 7 ZZ



Markings and polarity of terminals (cables) for counter-clockwise rotation, seen from the shaft

1 COMMUTATOR

Red wire : +
White wire : -

2 COMMUTATORS

1 st comm.	Blue wire: +	2 nd comm.	yellow wire: +
	White wire: -		green wire: -

ELECTRICAL OPTIONS

DESCRIPTION	SYMB	UNIT		VALUES										
				6	20	30	40	50	60	80	100	120	150	200
E.M.F at 1 000 rpm	E_n	V	1 com.	6	20	30	40	50	60	80	100	120	150	200
			2 com.	2 x 20	2 x 30		2 x 50	2 x 60		2 x 100				
Voltage gradient	C_v	V/rpm	1 com.	0,006	0,02	0,03	0,04	0,05	0,06	0,08	0,1	0,12	0,15	0,2
			2 com.	2 x 0,02	2 x 0,03		2 x 0,05	2 x 0,06		2 x 0,1				
Armature resistance	R_a		1 com.	1,5	12	28	45	70	100	180	280	400	640	900
			2 com.	2 x 24	2 x 55		2 x 150	2 x 200		2 x 470				
Max thermal load	I_{th}	A	1 com.	1.4	0,55	0,35	0,25	0,22	0,18	0,14	0,11	0,09	0,07	0,07
			2 com.	2 x 0,23	2 x 0,14		2 x 0,09	2 x 0,09		2 x 0,05				
Max. Allowed speed	n_a	rpm	EG			12000			10000	7500	6000	5000	4000	3000
			CA			6000			5000	3750	3000	2500	2000	1500

BRUSHES

GRADE	PART NO	MAX OUTPUT VOLTAGE	DIMENSIONS	QUANTITY
EG - Electrographite	/0002607	600 V	3,1 x 4,1 x 12,5 mm	4
CA - Silver-graphite	/0001397	< 300 V		

RE.0444N - Normal

Direct Current Tachometer generator

PRODUCT DESCRIPTION

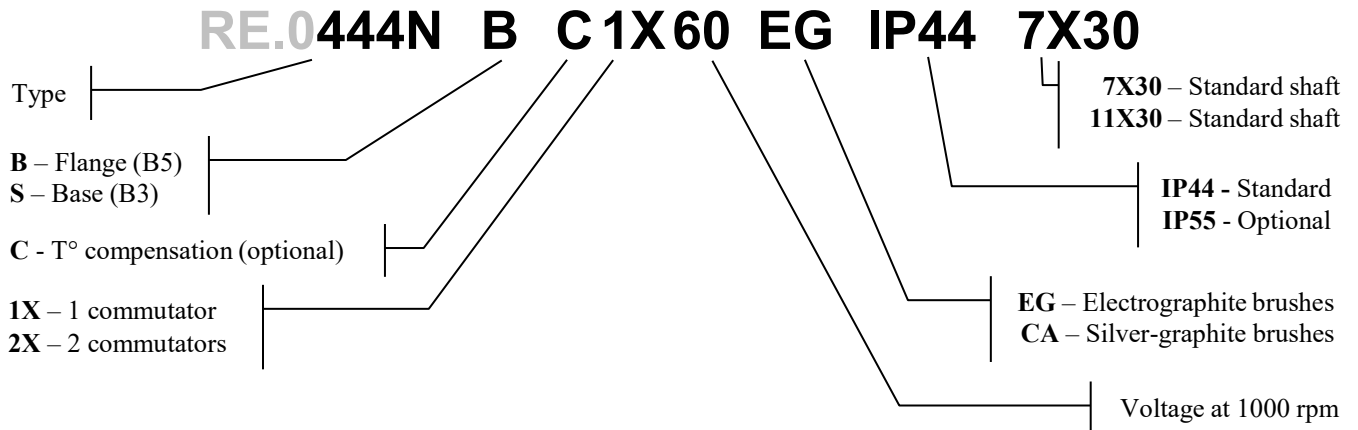

When inquiring, please advise the serial number of the tachogenerator to be replaced