

RE.0588

Direct Current Tachometer generator



- Destination :**
- Industrial applications
 - Low speed use

- Description :**
- DC tachometer generator with low ripple
 - Permanent magnet-excitation
 - Terminal box
 - Available with one or two commutators
 - Many options

		1 commutator	2 commutators
A	mm	199	221
B	mm	27	49
C	mm	195	217

DIAGRAMS

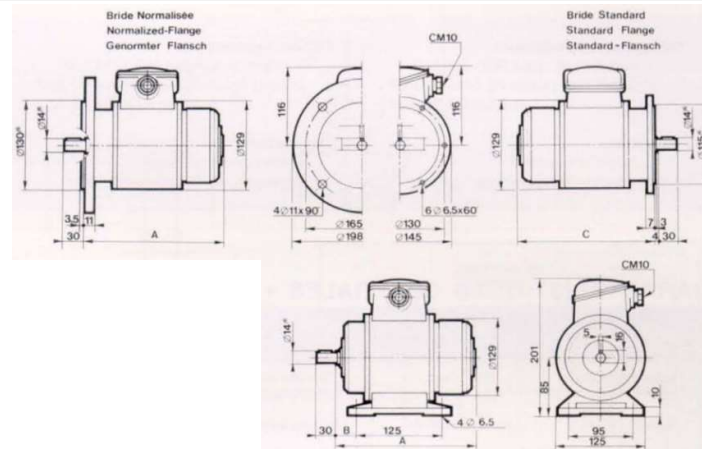

MAIN CHARACTERISTICS

DESIGNATION	SYMB	VALUE	CONSTRUCTION DETAILS	
Max. speed	n_m	8 000 rpm	Number of poles	2
Moment of inertia	J	7.50 Kg cm ²	Armature slots number	29
No-load driving torque	M_r	4.50 N.cm	Commutator blades number	87
Max. radial shaft stress	F	3.0 da N	Insulation class	B (IEC 34-1)
Maximum E.M.F.	E_m	600 V	Operating temperature	-30 +130 °C
Maximum linearity error	ΔE	$\leq 0,15 \% E_T$	Climatic protection	C _a (IEC 68-1)
Overall ripple rate (peak to peak)	ΔE_c	$\leq 0,4 \% E_c$	Ingress protection	IP54 (IEC 34-5)
Rotation harmonics (f=2 p.n)	ΔE_p	$\leq 0,1 \% E_c$	Direction of rotation	reversible
Slots harmonics (f=Z.n.)	ΔE_z	$\leq 0,3 \% E_c$	Excitation: Permanent magnets:	Alnico
Calibration precision	ΔE_o	$\pm 1 \% E_{T_o}$		
E.M.F. temperature drift				
Not compensated	ΔE_e	-		
Compensated		0,005 %/°C		
Time constant	C_t	7.5 ms		
*Filter : Time constant		1 ms		
Load current		5 mA		
Speed		1 000 rpm		
			Weight	7.9 kg (1 commutator) 8.6 kg (2 commutators)



MECHANICAL OPTIONS

	MOUNTING SIDE			OPPOSITE MOUNTING SIDE (upon request)		
	D (mm)	L (mm)	Bearings	D (mm)	L (mm)	Bearings
Standard	14	30	15 x 35 x 11 ZZ	14	30	15 x 35 x 11 ZZ
Max	14	-	15 x 35 x 11 ZZ	14	-	15 x 35 x 11 ZZ

Various adaptors available for mounting devices on the rear of the tachometer generator.



Markings and polarity of terminals (cables) for counter-clockwise rotation, seen from the shaft.

1 COMMUTATOR	2 COMMUTATORS
A1 : +	A1 : +
A2 : -	A2 : -

ELECTRICAL OPTIONS

DESCRIPTION	SYMB	UNIT	VALUES											
			Min.										Max.	
E.M.F. at 1 000 rpm	E _n	V	1 coll.	30	60	100	110	120	150	200	300	600	700	1 000
			2 coll.	2 x 60		2 x 100		2 x 120		2 x 200		2 x 600		
Voltage gradient	C _v	V/tr/mn	1 coll.	0,03	0,06	0,10	0,11	0,12	0,15	0,20	0,30	0,60	0,70	1,00
			2 coll.	2 x 0,06		2 x 0,10		2 x 0,12		2 x 0,20		2 x 0,60		
Armature resistance	R _a	Ω	1 coll.	4	12	35	40	50	75	130	300	1 300	1 900	2 600
			2 coll.	2 x 25		2 x 80		2 x 100		2 x 300		2 x 1 700		
Max thermal load	I _{th}	A	1 coll.	1.80	0,90	0,55	0,45	0,45	0,35	0,30	0,18	0,09	0,07	0,06
			2 coll.	2 x 0,45		2 x 0,5		2 x 0,25		2 x 0,10		2 x 0,045		
Max. Allowed speed	n _a	Tr/mn	1 coll.	8 000	5 000	3 000	2 700	2 500	2 000	1 500	1 000	500	425	300
			2 coll.	5 000		3 000		2 500		1 500		500		

BRUSHES

GRADE	CODE	APPLICATION LIMITS	DIMENSIONS	NUMBER
EG – Electrographite		Recommended for high speed and E.M.F. < 300 V		4 or 8
CA – Silver-graphite		Standard F.E.M.		

PRODUCT DESCRIPTION

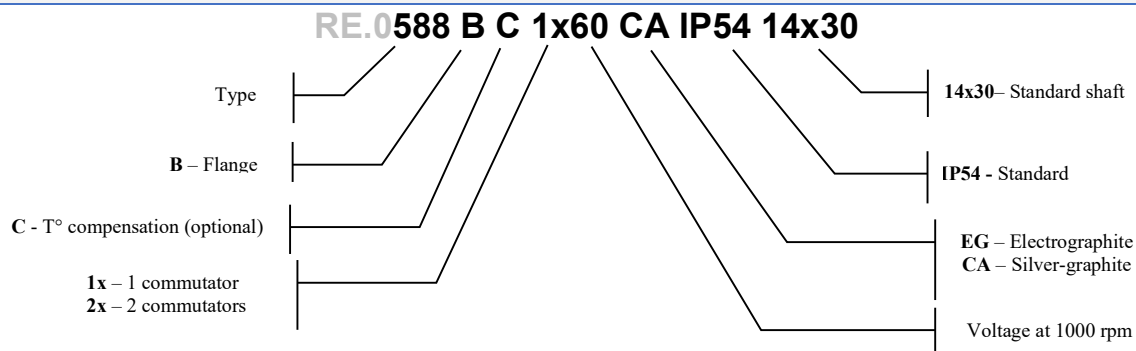

When inquiring, please advise the serial number of the tachogenerator to be replaced.