

BQAr 132

DIMENSIONI DI INGOMBRO - OVERALL DIMENSIONS

Dimensions [mm]

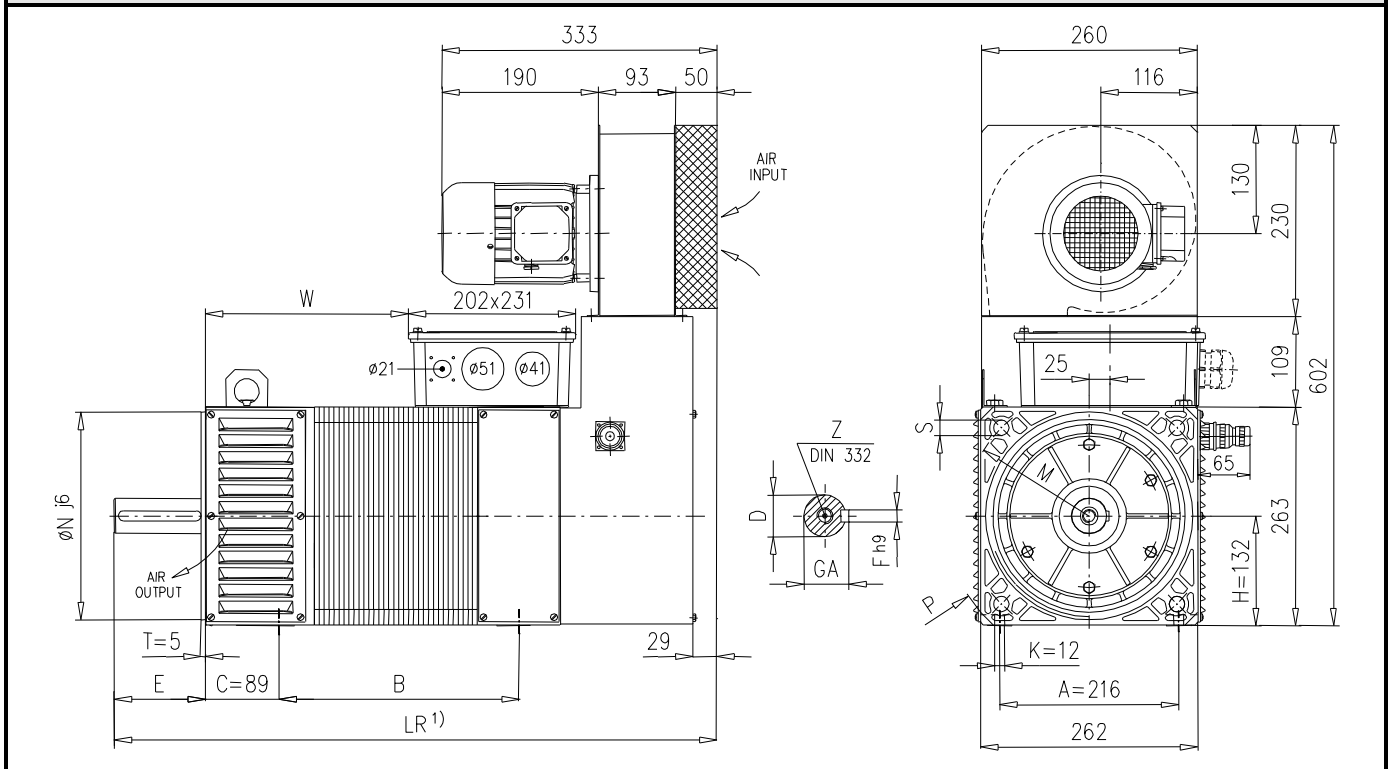

Size	B	D	E	F	GA	LR	LR1	M	N	P	S	W	Z
132S	250	42 ^{k6} (38 ^{k6})	110 (80) ²⁾	12 (10) ²⁾	45 (41) ²⁾	690	115 ³⁾	300 (265) ²⁾	250 (230) ²⁾	350 (300) ²⁾	18.5 (14.5) ²⁾	205	M16 (M12) ²⁾
132M	280	42 ^{k6}	110	12	45	730		300	250	350	18.5	245	
132L	315					765						280	
132P	355					795						310	
132X	400					855						370	

- 1) Per motori con freno aggiungere la quota LR1 – For motors with brake add LR1 quote
- 2) Opzione disponibile a richiesta – Option available on request
Albero ridotto disponibile solo per BQAr132S – Reduced shaft available for BQAr132S only
- 5) BQAr: Freno tipo K8 / K8D/NIA16/BFK 18/BFK 20 – Brake type K8 / K8D/NIA16/BFK 18/BFK 20
Vedere paragrafo B.03 condizioni di montaggio raccomandate – See recommended mounting positions par. B.03
Pressacavi non forniti – Cable glands not included in the supply

Attenzione:
Le dimensioni sono indicative e sono soggette a variazioni e/o modifiche senza preavviso.

Attention:
Dimension are indicative and can be changed without notice.