

PREDISP. PER RE0444

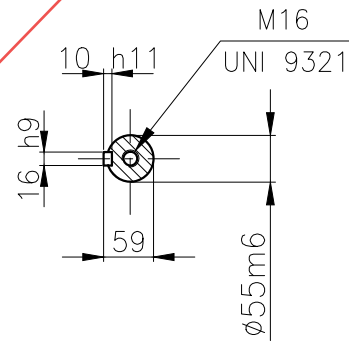

SEZ. A-A

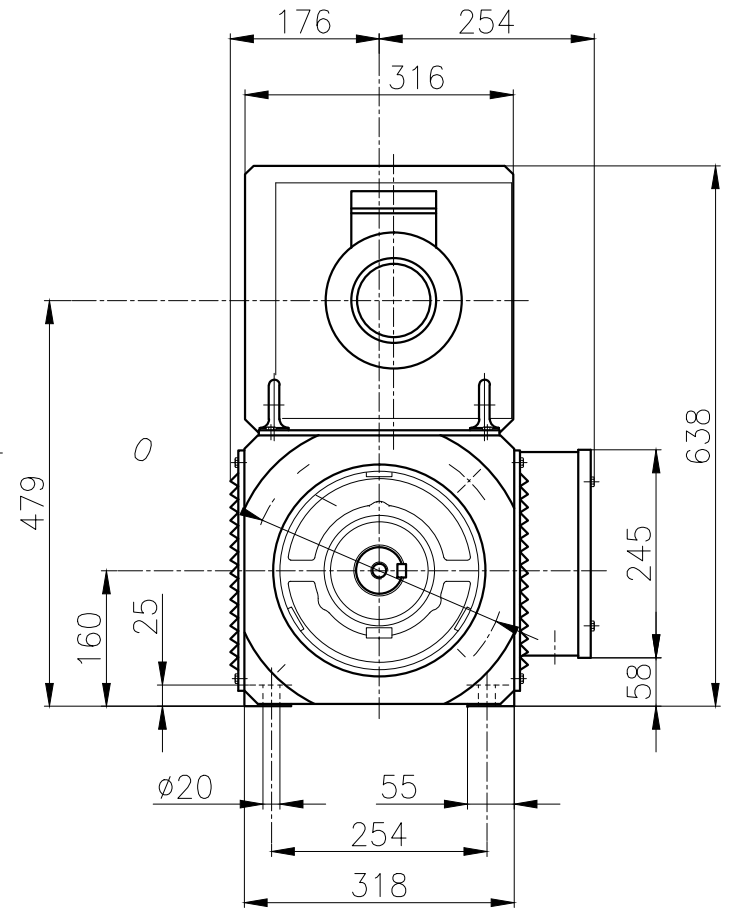

Modifiche : - - - - -	OUTLINE D.C. MOTOR TYPE RA 160 N P PVA/B3 TERMINAL BOX ON THE RIGHT SIDE DRIVE END VIEW IC 06 - IM 1001 - IP 23	INGOMBRO MOTORE A C.C. TIPO RA 160 N P PVA/B3 SCATOLA CAVI A DESTRA VISTA L.A. IC 06 - IM 1001 - IP 23													
	ENCOMBREMENT MOTEUR A C.C. TYPE RA 160 N P PVA/B35 BOITE A BORNES A DROITE VUE COTE ENTRAINEMENT IC 06 - IM 1001 - IP 23	A TERMINE DI LEGGE CI RISERVAMO LA PROPRIETA' DI QUESTO DISEGNO CON IL DIVIETO DI RIPRODURLO O DI RENDERLO NOTO A TERZI SENZA LA NOSTRA AUTORIZZAZIONE.		<table border="1"> <tr> <td></td> <td>Firma</td> <td>Data</td> </tr> <tr> <td>Disegn.</td> <td>F.Gadrino</td> <td>25/09/18</td> </tr> <tr> <td>Controll.</td> <td>F.Gadrino</td> <td>25/09/18</td> </tr> <tr> <td>Visto</td> <td>F.Gadrino</td> <td>25/09/18</td> </tr> </table>		Firma	Data	Disegn.	F.Gadrino	25/09/18	Controll.	F.Gadrino	25/09/18	Visto	F.Gadrino
	Firma	Data													
Disegn.	F.Gadrino	25/09/18													
Controll.	F.Gadrino	25/09/18													
Visto	F.Gadrino	25/09/18													
		N° DIS. DRAW. N° PLAN N°	R 7F 7 AA 700	MOD. 0											