

SIEMENS



Installation manual

SINAMICS

SINAMICS G120 frequency converters

PM240-2 Power Modules,
IP20 / push-through technology (PT)

Edition

01/2018

www.siemens.com/drives

SIEMENS

SINAMICS

SINAMICS G120 Power Module PM240-2

Hardware Installation Manual

Preface

Fundamental safety instructions **1**

Introduction **2**

Installing/mounting **3**

Connecting-up **4**

Service and maintenance **5**

Technical data **6**

Spare parts **7**

Accessories **8**

Appendix **A**

01/2018



01/2018

A5E33294624B AJ

Legal information

Warning notice system

This manual contains notices you have to observe in order to ensure your personal safety, as well as to prevent damage to property. The notices referring to your personal safety are highlighted in the manual by a safety alert symbol, notices referring only to property damage have no safety alert symbol. These notices shown below are graded according to the degree of danger.

| |
|--|
|  DANGER |
| indicates that death or severe personal injury will result if proper precautions are not taken. |
|  WARNING |
| indicates that death or severe personal injury may result if proper precautions are not taken. |
|  CAUTION |
| indicates that minor personal injury can result if proper precautions are not taken. |
| NOTICE |
| indicates that property damage can result if proper precautions are not taken. |

If more than one degree of danger is present, the warning notice representing the highest degree of danger will be used. A notice warning of injury to persons with a safety alert symbol may also include a warning relating to property damage.

Qualified Personnel

The product/system described in this documentation may be operated only by **personnel qualified** for the specific task in accordance with the relevant documentation, in particular its warning notices and safety instructions. Qualified personnel are those who, based on their training and experience, are capable of identifying risks and avoiding potential hazards when working with these products/systems.

Proper use of Siemens products

Note the following:

| |
|--|
|  WARNING |
| Siemens products may only be used for the applications described in the catalog and in the relevant technical documentation. If products and components from other manufacturers are used, these must be recommended or approved by Siemens. Proper transport, storage, installation, assembly, commissioning, operation and maintenance are required to ensure that the products operate safely and without any problems. The permissible ambient conditions must be complied with. The information in the relevant documentation must be observed. |

Trademarks

All names identified by ® are registered trademarks of Siemens AG. The remaining trademarks in this publication may be trademarks whose use by third parties for their own purposes could violate the rights of the owner.

Disclaimer of Liability

We have reviewed the contents of this publication to ensure consistency with the hardware and software described. Since variance cannot be precluded entirely, we cannot guarantee full consistency. However, the information in this publication is reviewed regularly and any necessary corrections are included in subsequent editions.

Preface

Changes with respect to Edition 08/2017

The Power Module in frame size FSG has been integrated

Table of contents

| | | |
|----------|--|-----------|
| | Preface | 3 |
| 1 | Fundamental safety instructions | 9 |
| 1.1 | General safety instructions | 9 |
| 1.2 | Equipment damage due to electric fields or electrostatic discharge | 14 |
| 1.3 | Warranty and liability for application examples | 15 |
| 1.4 | Industrial security | 16 |
| 1.5 | Residual risks of power drive systems..... | 18 |
| 2 | Introduction..... | 19 |
| 3 | Installing/mounting | 21 |
| 3.1 | Installation conditions..... | 21 |
| 3.2 | EMC-compliant installation of a machine or system..... | 24 |
| 3.2.1 | Control cabinet..... | 25 |
| 3.2.2 | Cables | 26 |
| 3.2.3 | Electromechanical components..... | 29 |
| 3.3 | Power losses and air cooling requirements | 30 |
| 3.4 | Mounting the Power Modules | 31 |
| 3.4.1 | Sequence for installing the Power Module | 32 |
| 3.4.2 | Dimension drawings and drilling dimensions for built-in units - IP20 devices | 33 |
| 3.4.3 | Dimension drawings and drilling dimensions for PT Power Modules..... | 36 |
| 3.4.4 | Mounting the shield plates | 40 |
| 3.4.5 | Mounting the shield plate, FSA ... FSC..... | 40 |
| 3.4.6 | Mounting the shield plate, FSD ... FSG | 41 |
| 3.4.7 | Hoisting gear FSD ... FSG | 44 |
| 3.4.8 | Additional components..... | 45 |
| 4 | Connecting-up | 47 |
| 4.1 | Permissible line supplies | 50 |
| 4.1.1 | TN line system | 51 |
| 4.1.2 | TT line system..... | 52 |
| 4.1.3 | IT system | 53 |
| 4.1.4 | Protective conductor | 54 |
| 4.2 | Connecting the line and motor cable at the inverter..... | 56 |
| 4.2.1 | Connection overview..... | 56 |
| 4.2.2 | Length of the motor cable | 60 |
| 4.2.3 | Connection terminals at the inverter | 62 |
| 4.2.4 | Establishing connections | 63 |
| 4.3 | STO via Power Module terminals | 68 |
| 4.4 | Connecting the motor to the inverter in a star or delta connection..... | 70 |

| | | |
|----------|--|------------|
| 5 | Service and maintenance | 71 |
| 5.1 | Maintenance..... | 72 |
| 5.2 | Commissioning after a long storage time | 73 |
| 5.3 | Replacing a fan | 74 |
| 5.3.1 | Fan replacement FSA ... FSC | 75 |
| 5.3.2 | Fan replacement FSD ... FSF | 76 |
| 5.3.3 | FSG fan replacement..... | 77 |
| 6 | Technical data | 79 |
| 6.1 | Electromagnetic compatibility - Overview | 80 |
| 6.2 | Ambient conditions..... | 81 |
| 6.3 | Overload capability of the inverter | 83 |
| 6.4 | Cable cross-sections and tightening torques..... | 85 |
| 6.5 | Technical data, 200 V inverters | 86 |
| 6.5.1 | General data, 200 V inverters | 87 |
| 6.5.2 | Specific technical data, 200 V inverters | 89 |
| 6.5.3 | Current derating depending on the pulse frequency, 200 V inverters | 96 |
| 6.6 | Technical data, 400 V inverters | 97 |
| 6.6.1 | General data, 400 V inverters | 98 |
| 6.6.2 | Specific technical data, 400 V inverters | 100 |
| 6.6.3 | Current derating depending on the pulse frequency, 400 V inverters | 108 |
| 6.7 | Technical data, 690 V inverters | 109 |
| 6.7.1 | General data, 690 V inverters | 110 |
| 6.7.2 | Specific technical data, 690 V inverters | 112 |
| 6.7.3 | Current derating depending on the pulse frequency, 690 V inverters | 115 |
| 6.8 | Restrictions for special ambient conditions..... | 116 |
| 6.9 | Electromagnetic compatibility of variable-speed drives | 119 |
| 6.9.1 | Inverter applications..... | 120 |
| 6.9.1.1 | Operation in the Second Environment..... | 120 |
| 6.9.1.2 | Operation in the First Environment | 122 |
| 6.9.2 | Typical harmonic currents..... | 123 |
| 6.9.3 | EMC limit values in South Korea | 124 |
| 7 | Spare parts | 125 |
| 8 | Accessories | 127 |
| 8.1 | Top shield plate - FSD ... FSG | 128 |
| 8.2 | Mounting frames for PT power modules..... | 129 |
| 8.2.1 | Mounting instructions with mounting frame | 132 |
| 8.3 | Mounting grips for PT Power Modules..... | 133 |
| 8.4 | Line reactor | 134 |
| 8.5 | Line filter..... | 137 |
| 8.6 | Braking resistor | 139 |
| 8.6.1 | Connecting a braking resistor | 142 |
| 8.6.2 | Technical data of the braking resistor | 144 |

| | | |
|----------|--|------------|
| 8.7 | Connecting a motor holding brake | 147 |
| 8.7.1 | Technical data of the brake relay? | 147 |
| 8.7.2 | Connections and circuit diagrams..... | 148 |
| 8.7.3 | Mounting and connecting the brake relay..... | 149 |
| 8.8 | Output reactor | 150 |
| 8.9 | du/dt filter plus VPL..... | 155 |
| A | Appendix..... | 157 |
| A.1 | Manuals and technical support | 157 |
| A.1.1 | Manuals for your inverter | 157 |
| A.1.2 | Configuring support..... | 159 |
| A.1.3 | Product Support | 160 |
| A.2 | Disposal | 161 |
| A.3 | Directives and standards | 162 |
| A.4 | Abbreviations | 164 |
| | Index..... | 165 |

Fundamental safety instructions

1.1 General safety instructions



WARNING

Electric shock and danger to life due to other energy sources

Touching live components can result in death or severe injury.

- Only work on electrical devices when you are qualified for this job.
- Always observe the country-specific safety rules.

Generally, the following six steps apply when establishing safety:

1. Prepare for disconnection. Notify all those who will be affected by the procedure.
2. Isolate the drive system from the power supply and take measures to prevent it being switched back on again.
3. Wait until the discharge time specified on the warning labels has elapsed.
4. Check that there is no voltage between any of the power connections, and between any of the power connections and the protective conductor connection.
5. Check whether the existing auxiliary supply circuits are de-energized.
6. Ensure that the motors cannot move.
7. Identify all other dangerous energy sources, e.g. compressed air, hydraulic systems, or water. Switch the energy sources to a safe state.
8. Check that the correct drive system is completely locked.

After you have completed the work, restore the operational readiness in the inverse sequence.



WARNING

Risk of electric shock and fire from supply networks with an excessively high impedance

Excessively low short-circuit currents can lead to the protective devices not tripping or tripping too late, and thus causing electric shock or a fire.

- In the case of a conductor-conductor or conductor-ground short-circuit, ensure that the short-circuit current at the point where the inverter is connected to the line supply at least meets the minimum requirements for the response of the protective device used.
- You must use an additional residual-current device (RCD) if a conductor-ground short circuit does not reach the short-circuit current required for the protective device to respond. The required short-circuit current can be too low, especially for TT supply systems.



! WARNING

Risk of electric shock and fire from supply networks with an excessively low impedance

Excessively high short-circuit currents can lead to the protective devices not being able to interrupt these short-circuit currents and being destroyed, and thus causing electric shock or a fire.

- Ensure that the prospective short-circuit current at the line terminal of the inverter does not exceed the breaking capacity (SCCR or I_{cc}) of the protective device used.



! WARNING

Electric shock if there is no ground connection

For missing or incorrectly implemented protective conductor connection for devices with protection class I, high voltages can be present at open, exposed parts, which when touched, can result in death or severe injury.

- Ground the device in compliance with the applicable regulations.



! WARNING

Electric shock due to connection to an unsuitable power supply

When equipment is connected to an unsuitable power supply, exposed components may carry a hazardous voltage that might result in serious injury or death.

- Only use power supplies that provide SELV (Safety Extra Low Voltage) or PELV- (Protective Extra Low Voltage) output voltages for all connections and terminals of the electronics modules.



! WARNING

Electric shock due to equipment damage

Improper handling may cause damage to equipment. For damaged devices, hazardous voltages can be present at the enclosure or at exposed components; if touched, this can result in death or severe injury.

- Ensure compliance with the limit values specified in the technical data during transport, storage and operation.
- Do not use any damaged devices.



! WARNING

Electric shock due to unconnected cable shield

Hazardous touch voltages can occur through capacitive cross-coupling due to unconnected cable shields.

- As a minimum, connect cable shields and the conductors of power cables that are not used (e.g. brake cores) at one end at the grounded housing potential.

**! WARNING****Arcing when a plug connection is opened during operation**

Opening a plug connection when a system is operation can result in arcing that may cause serious injury or death.

- Only open plug connections when the equipment is in a voltage-free state, unless it has been explicitly stated that they can be opened in operation.

**! WARNING****Electric shock due to residual charges in power components**

Because of the capacitors, a hazardous voltage is present for up to 5 minutes after the power supply has been switched off. Contact with live parts can result in death or serious injury.

- Wait for 5 minutes before you check that the unit really is in a no-voltage condition and start work.

NOTICE**Property damage due to loose power connections**

Insufficient tightening torques or vibration can result in loose power connections. This can result in damage due to fire, device defects or malfunctions.

- Tighten all power connections to the prescribed torque.
- Check all power connections at regular intervals, particularly after equipment has been transported.

! WARNING**Spread of fire from built-in devices**

In the event of fire outbreak, the enclosures of built-in devices cannot prevent the escape of fire and smoke. This can result in serious personal injury or property damage.

- Install built-in units in a suitable metal cabinet in such a way that personnel are protected against fire and smoke, or take other appropriate measures to protect personnel.
- Ensure that smoke can only escape via controlled and monitored paths.

 **WARNING**

Active implant malfunctions due to electromagnetic fields

Inverters generate electromagnetic fields (EMF) in operation. People with active implants in the immediate vicinity of this equipment are at particular risk.

- As the operator of an EMF-emitting installation, assess the individual risks of persons with active implants. The following clearances are usually adequate:
 - No clearance to closed control cabinets and shielded MOTION-CONNECT supply cables
 - Forearm length (approx. 35 cm clearance) to distributed drive systems and open control cabinets

 **WARNING**

Unexpected movement of machines caused by radio devices or mobile phones

When radio devices or mobile phones with a transmission power $> 1\text{ W}$ are used in the immediate vicinity of components, they may cause the equipment to malfunction. Malfunctions may impair the functional safety of machines and can therefore put people in danger or lead to property damage.

- If you come closer than around 2 m to such components, switch off any radios or mobile phones.
- Use the "SIEMENS Industry Online Support app" only on equipment that has already been switched off.

NOTICE

Damage to motor insulation due to excessive voltages

When operated on systems with grounded line conductor or in the event of a ground fault in the IT system, the motor insulation can be damaged by the higher voltage to ground. If you use motors that have insulation that is not designed for operation with grounded line conductors, you must perform the following measures:

- IT system: Use a ground fault monitor and eliminate the fault as quickly as possible.
- TN or TT systems with grounded line conductor: Use an isolating transformer on the line side.

 **WARNING**

Fire due to inadequate ventilation clearances

Inadequate ventilation clearances can cause overheating of components with subsequent fire and smoke. This can cause severe injury or even death. This can also result in increased downtime and reduced service lives for devices/systems.

- Ensure compliance with the specified minimum clearance as ventilation clearance for the respective component.

 **WARNING****Unrecognized dangers due to missing or illegible warning labels**

Dangers might not be recognized if warning labels are missing or illegible. Unrecognized dangers may cause accidents resulting in serious injury or death.

- Check that the warning labels are complete based on the documentation.
- Attach any missing warning labels to the components, where necessary in the national language.
- Replace illegible warning labels.

NOTICE**Device damage caused by incorrect voltage/insulation tests**

Incorrect voltage/insulation tests can damage the device.

- Before carrying out a voltage/insulation check of the system/machine, disconnect the devices as all converters and motors have been subject to a high voltage test by the manufacturer, and therefore it is not necessary to perform an additional test within the system/machine.

 **WARNING****Unexpected movement of machines caused by inactive safety functions**

Inactive or non-adapted safety functions can trigger unexpected machine movements that may result in serious injury or death.

- Observe the information in the appropriate product documentation before commissioning.
- Carry out a safety inspection for functions relevant to safety on the entire system, including all safety-related components.
- Ensure that the safety functions used in your drives and automation tasks are adjusted and activated through appropriate parameterizing.
- Perform a function test.
- Only put your plant into live operation once you have guaranteed that the functions relevant to safety are running correctly.

Note**Important safety notices for Safety Integrated functions**

If you want to use Safety Integrated functions, you must observe the safety notices in the Safety Integrated manuals.

1.2 Equipment damage due to electric fields or electrostatic discharge

Electrostatic sensitive devices (ESD) are individual components, integrated circuits, modules or devices that may be damaged by either electric fields or electrostatic discharge.



NOTICE

Equipment damage due to electric fields or electrostatic discharge

Electric fields or electrostatic discharge can cause malfunctions through damaged individual components, integrated circuits, modules or devices.

- Only pack, store, transport and send electronic components, modules or devices in their original packaging or in other suitable materials, e.g. conductive foam rubber or aluminum foil.
- Only touch components, modules and devices when you are grounded by one of the following methods:
 - Wearing an ESD wrist strap
 - Wearing ESD shoes or ESD grounding straps in ESD areas with conductive flooring
- Only place electronic components, modules or devices on conductive surfaces (table with ESD surface, conductive ESD foam, ESD packaging, ESD transport container).

1.3 Warranty and liability for application examples

Application examples are not binding and do not claim to be complete regarding configuration, equipment or any eventuality which may arise. Application examples do not represent specific customer solutions, but are only intended to provide support for typical tasks.

As the user you yourself are responsible for ensuring that the products described are operated correctly. Application examples do not relieve you of your responsibility for safe handling when using, installing, operating and maintaining the equipment.

1.4 Industrial security

Note

Industrial security

Siemens provides products and solutions with industrial security functions that support the secure operation of plants, systems, machines and networks.

In order to protect plants, systems, machines and networks against cyber threats, it is necessary to implement – and continuously maintain – a holistic, state-of-the-art industrial security concept. Siemens' products and solutions constitute one element of such a concept.

Customers are responsible for preventing unauthorized access to their plants, systems, machines and networks. Such systems, machines and components should only be connected to an enterprise network or the Internet if and to the extent such a connection is necessary and only when appropriate security measures (e.g. firewalls and/or network segmentation) are in place.

For additional information on industrial security measures that may be implemented, please visit:

Industrial security (<http://www.siemens.com/industrialsecurity>)

Siemens' products and solutions undergo continuous development to make them more secure. Siemens strongly recommends that product updates are applied as soon as they are available and that the latest product versions are used. Use of product versions that are no longer supported, and failure to apply the latest updates may increase customer's exposure to cyber threats.

To stay informed about product updates, subscribe to the Siemens Industrial Security RSS Feed at:

Industrial security (<http://www.siemens.com/industrialsecurity>)

Further information is provided on the Internet:

Industrial Security Configuration Manual
(<https://support.industry.siemens.com/cs/ww/en/view/108862708>)

 **WARNING****Unsafe operating states resulting from software manipulation**

Software manipulations (e.g. viruses, trojans, malware or worms) can cause unsafe operating states in your system that may lead to death, serious injury, and property damage.

- Keep the software up to date.
- Incorporate the automation and drive components into a holistic, state-of-the-art industrial security concept for the installation or machine.
- Make sure that you include all installed products into the holistic industrial security concept.
- Protect files stored on exchangeable storage media from malicious software by with suitable protection measures, e.g. virus scanners.
- Protect the drive against unauthorized changes by activating the "know-how protection" drive function.

1.5 Residual risks of power drive systems

When assessing the machine- or system-related risk in accordance with the respective local regulations (e.g., EC Machinery Directive), the machine manufacturer or system installer must take into account the following residual risks emanating from the control and drive components of a drive system:

1. Unintentional movements of driven machine or system components during commissioning, operation, maintenance, and repairs caused by, for example,
 - Hardware and/or software errors in the sensors, control system, actuators, and cables and connections
 - Response times of the control system and of the drive
 - Operation and/or environmental conditions outside the specification
 - Condensation/conductive contamination
 - Parameterization, programming, cabling, and installation errors
 - Use of wireless devices/mobile phones in the immediate vicinity of electronic components
 - External influences/damage
 - X-ray, ionizing radiation and cosmic radiation
2. Unusually high temperatures, including open flames, as well as emissions of light, noise, particles, gases, etc., can occur inside and outside the components under fault conditions caused by, for example:
 - Component failure
 - Software errors
 - Operation and/or environmental conditions outside the specification
 - External influences/damage
3. Hazardous shock voltages caused by, for example:
 - Component failure
 - Influence during electrostatic charging
 - Induction of voltages in moving motors
 - Operation and/or environmental conditions outside the specification
 - Condensation/conductive contamination
 - External influences/damage
4. Electrical, magnetic and electromagnetic fields generated in operation that can pose a risk to people with a pacemaker, implants or metal replacement joints, etc., if they are too close
5. Release of environmental pollutants or emissions as a result of improper operation of the system and/or failure to dispose of components safely and correctly
6. Influence of network-connected communication systems, e.g. ripple-control transmitters or data communication via the network

For more information about the residual risks of the drive system components, see the relevant sections in the technical user documentation.

Introduction

Overview

The Power Modules belong to the modular family of SINAMICS G120 inverters. A modular inverter comprises Control Unit and Power Module.

Depending on the power rating in frame sizes FSA ... FSG, the following Power Module versions are supplied:

- 1 AC 200 V 0.55 kW ... 4 kW for line voltages from 1 AC 200 V ... 240 V
- 3 AC 200 V 0.55 kW ... 55 kW for line voltages from 3 AC 200 V ... 240 V
- 3 AC 400 V 0.55 kW ... 250 kW for line voltages from 3 AC 380 V ... 480 V
- 3 AC 690 V 11 kW ... 250 kW for line voltages from 3 AC 500 V ... 690 V

Control Units for the Power Modules

You can operate the Power Modules with a Control Unit from one of the following listed families.

- CU230P-2
- CU240B-2
- CU240E-2
- CU250S-2

For Power Modules FSA ... FSC, you require a Control Unit with firmware version V4.4 or higher.

For Power Modules FSD ... FSF, you require a Control Unit with firmware version V4.7 HF8 or higher.

For Power Modules FSG, you require a Control Unit with firmware version V4.7 SP9 or higher.

Note

Commissioning the inverter

You must first commission the inverter before you can use it. Commissioning is described in the Operating Instructions of the relevant Control Unit.



Manuals for your inverter (Page 157)

STO independent of the Control Unit

Using the PM240-2 Power Modules, frame sizes FSD, FSE, FSF and FSG, you can implement the "Safe Torque Off" safety function (STO), corresponding to PL e according to EN 13849-1 and SIL 3 according to IEC61508.



STO via Power Module terminals (Page 68).

Permissible motors

Note

Motors for inverter operation

Only use motors that are suitable for operation with inverters with a DC link.

Motors for 200 V Power Modules

For the 200 V Power Modules, induction motors are permissible in the range from 25% ... 150% of the inverter power without any restrictions.

Motors for 400 V Power Modules

For the 400 V Power Modules, induction motors are permissible in the range from 25 % ... 150 % of the inverter power without any restrictions.

Motors for 690 V Power Modules

For the 690 V Power Modules, induction motors are permissible in the range from 50 % ... 150 % of the inverter power without any restrictions.

Continuous development within the scope of product maintenance

Inverter components are being continuously developed within the scope of product maintenance. Product maintenance includes, for example, measures to increase the ruggedness or hardware changes which become necessary as components are discontinued.

These further developments are "spare parts-compatible" and do not change the article number.



In the scope of such spare parts-compatible ongoing development, plug connector or connection positions are sometimes slightly modified. This does not cause any problems when the components are properly used. Please take this fact into consideration in special installation situations (e.g. allow sufficient reserve regarding the cable length).

Installing/mounting



3.1 Installation conditions

General installation conditions

When installing the Power Modules carefully observe the conditions listed below in order to guarantee reliable, continuous and disturbance-free operation.

- The Power Modules are designed for installation in a control cabinet.
- The Power Modules are certified for use in environments with degree of pollution 2 without condensation; i.e. in environments where no conductive pollution/dirt occurs.
- The built-in units fulfill IP20 degree of protection.
- Fast temperature changes of the air drawn in (e.g. by using cooling units) are not permitted due to the risk of condensation.
- Condensation is not permissible when switching on.
- You can find the permissible conductor cross-sections for the terminals in:
 -  Connection terminals at the inverter (Page 62)
- The following section describes how you can install the Power Module in compliance with EMC regulations:
 -  EMC-compliant installation of a machine or system (Page 24)
- Devices in push-through technology – PT devices
 - PT devices have IP20 degree of protection and at the rear of the control cabinet they fulfil IP55.
 - PT devices, FSF: A pressure compensation valve is necessary for the cabinet in order to prevent underpressure in the cabinet.

Inverters for systems in the United States / Canada (UL/cUL)

- For a system configuration in conformance with UL/cUL, use the fuse types approved for UL/cUL, specified in the Technical data, or the circuit breakers under the following Internet address.
 -  Fuse types: Technical data (Page 79)
 -  Circuit breaker
(<https://support.industry.siemens.com/cs/ww/en/view/109486009>)
- The integrated semiconductor short-circuit protection does not provide cable protection.
- On the system side, provide **cable protection** in conformance with NEC or CEC, Part 1 and the local regulations.

- The inverters provide internal motor protection corresponding to UL61800-5-1.
Protection threshold:
 - 115% of the rated motor current entered for frame sizes FSA ... FSF
 - 120% of the rated motor current entered for frame size FSGYou enter the motor data values and the protection functions when commissioning the inverter. Please observe the details in the associated operating instructions.
- For frame sizes FSF and FSG, to connect the line supply and motor only use UL approved ring-type cable lugs (ZMVV), which are certified for the particular voltage, with a permissible current of at least 125% of the input and output current. Use the higher value as basis.
- Carefully note that for plants and systems in conformance with UL/cUL, the line and output voltage may not be higher than 600 V.
- Only use copper cables rated for 60 °C or 75 °C.
- FSE, IP20: Only use cables that are certified for temperatures of 75 °C to connect the braking resistor.
- FSE, PT: Only use cables that are certified for temperatures of 75 °C to connect the line supply, motor and braking resistor.
- The inverters are Open Type devices.
- The push-through FSD ... FSF inverters are Open Type devices. At the rear of the control cabinet they fulfil Enclosure Type 1.

Additional requirements for CSA compliance, frame sizes FSA ... FSC

Install the inverter with an external suppression device with the following properties:

- Surge protection device with the appropriate certification (category checking numbers VZCA and VZCA7)
- Rated supply voltage
 - 240 V (phase with respect to ground), 240 V (phase to phase) for 200 V inverters
 - 480 V (phase to phase) for 400 V inverters
- Terminal voltage, V_{PR}
 - max. 2000 V for 200 V inverters
 - max. 2500 V for 400 V inverters
- Overvoltage category III
- Pollution degree 2
- Suitable for SPD applications, type 1 or type 2

Alternatively, use a surge protection device, article number 5SD7 424-1 from Siemens AG.

Additional requirements relating to CSA conformance, frame sizes FSD ... FSG

Overvoltage category OVC III must be ensured for all connections of the power circuit. This can mean that a surge suppressor must be connected upstream on the line side. The rated voltage of the surge suppressor must not exceed the line voltage, and must guarantee the limit values (VPR) specified here.

| Line voltage | | Phase to ground | | Phase to phase | |
|----------------------|----------------------------|-----------------|--------|----------------|------|
| | | Rated voltage | VPR | Rated voltage | VPR |
| 3 AC 200 V ... 240 V | Grounded neutral conductor | 139 V | 2.5 kV | 240 V | 4 kV |
| | Grounded line conductor | 240 V | 4 kV | 240 V | 4 kV |
| 3 AC 380 V ... 480 V | Grounded neutral conductor | 277 V | 4 kV | 480 V | 4 kV |
| | Grounded line conductor | 480 V | 6 kV | 480 V | 4 kV |
| 3 AC 500 V ... 600 V | Grounded neutral conductor | 347 V | 6 kV | 600 V | 4 kV |
| | Grounded line conductor | 600 V | 6 kV | 600 V | 4 kV |

3.2 EMC-compliant installation of a machine or system

The inverter is designed for operation in industrial environments where strong electromagnetic fields are to be expected.

Reliable and disturbance-free operation is only guaranteed for EMC-compliant installation.

To achieve this, subdivide the control cabinet and the machine or system into EMC zones:

EMC zones

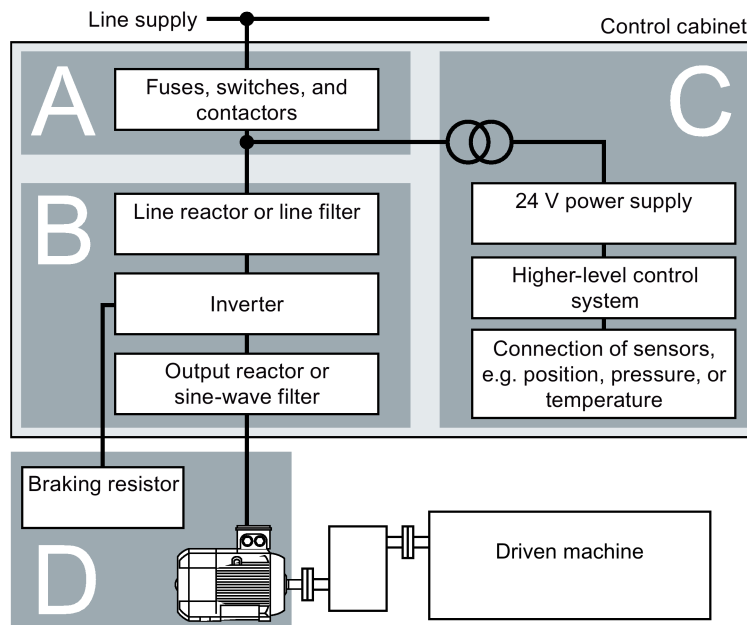

Figure 3-1 Example of the EMC zones of a plant or machine

Inside the control cabinet

- Zone A: Line supply connection
- Zone B: Power electronics
 Devices in Zone B generate energy-rich electromagnetic fields.
- Zone C: Control and sensors
 Devices in Zone C do not generate any energy-rich electromagnetic fields themselves, but their functions can be impaired by electromagnetic fields.

Outside the control cabinet

- Zone D: Motors, braking resistors
 Devices in Zone D generate electromagnetic fields with a significant amount of energy

3.2.1 Control cabinet

- Assign the various devices to zones in the control cabinet.
- Electromagnetically uncouple the zones from each other by means of one of the following actions:
 - Side clearance ≥ 25 cm
 - Separate metal enclosure
 - Large-area partition plates
- Route cables of various zones in separate cable harnesses or cable ducts.
- Install filters or isolation amplifiers at the interfaces of the zones.

Control cabinet assembly

- Connect the door, side panels, top and base plate of the control cabinet with the control cabinet frame using one of the following methods:
 - Electrical contact surface of several cm^2 for each contact location
 - Several screw connections
 - Short, finely stranded, braided copper wires with cross-sections $\geq 95 \text{ mm}^2 / 000 (3/0) (-2) \text{ AWG}$
- Install a shield support for shielded cables that are routed out of the control cabinet.
- Connect the PE bar and the shield support to the control cabinet frame through a large surface area to establish a good electrical connection.
- Mount the control cabinet components on a bare metal mounting plate.
- Connect the mounting plate to the control cabinet frame and PE bar and shield support through a large surface area to establish a good electrical connection.
- For screw connections onto painted or anodized surfaces, establish a good conductive contact using one of the following methods:
 - Use special (serrated) contact washers that cut through the painted or anodized surface.
 - Remove the insulating coating at the contact locations.

Measures required for several control cabinets

- Install equipotential bonding for all control cabinets.
- Screw the frames of the control cabinets together at several locations through a large surface area using serrated washers to establish a good electrical connection.
- In plants and systems where the control cabinets are lined up next to one another, and which are installed in two groups back to back, connect the PE bars of the two cabinet groups at as many locations as possible.

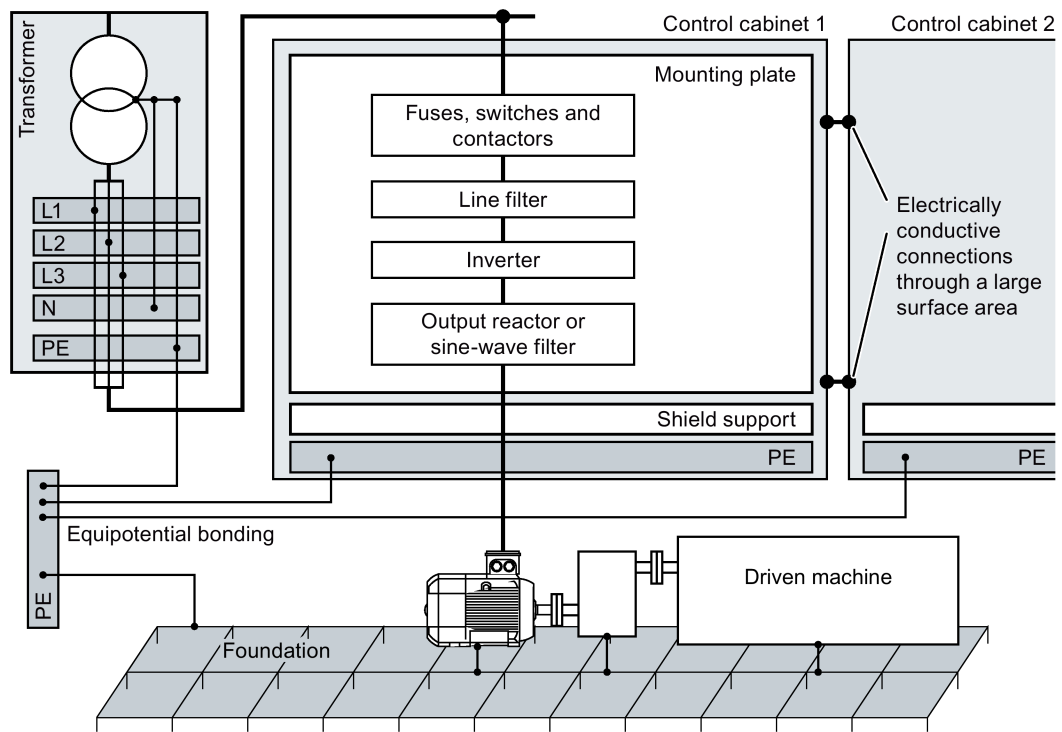

Figure 3-2 Grounding and high-frequency equipotential bonding measures in the control cabinet and in the plant/system

Further information

Additional information about EMC-compliant installation is available in the Internet:



EMC installation guideline

<https://support.industry.siemens.com/cs/ww/de/view/60612658/en>

3.2.2 Cables

Cables with a high level of interference and cables with a low level of interference are connected to the inverter:

- Cables with a high level of interference:
 - Cable between the line filter and inverter
 - Motor cable
 - Cable at the inverter DC link connection
 - Cable between the inverter and braking resistor
- Cables with a low level of interference:
 - Cable between the line and line filter
 - Signal and data cables

Cable routing inside the cabinet

- Route the power cables with a high level of interference so that there is a minimum clearance of 25 cm to cables with a low level of interference.

If the minimum clearance of 25 cm is not possible, insert separating metal sheets between the cables with a high level of interference and cables with a low level of interference. Connect these separating metal sheets to the mounting plate to establish a good electrical connection.

- Cables with a high level of interference and cables with a low level of interference may only cross over at right angles:
- Keep all of the cables as short as possible.
- Route all of the cables close to the mounting plates or cabinet frames.
- Route signal and data cables - as well as the associated equipotential bonding cables - parallel and close to one another.
- Twist incoming and outgoing unshielded individual conductors.

Alternatively, you can route incoming and outgoing conductors in parallel, but close to one another.

- Ground any unused conductors of signal and data cables at both ends.
- Signal and data cables must only enter the cabinet from one side, e.g. from below.
- Using shielded cables for the following connections:
 - Cable between the inverter and line filter
 - Cable between the inverter and output reactor or sine-wave filter

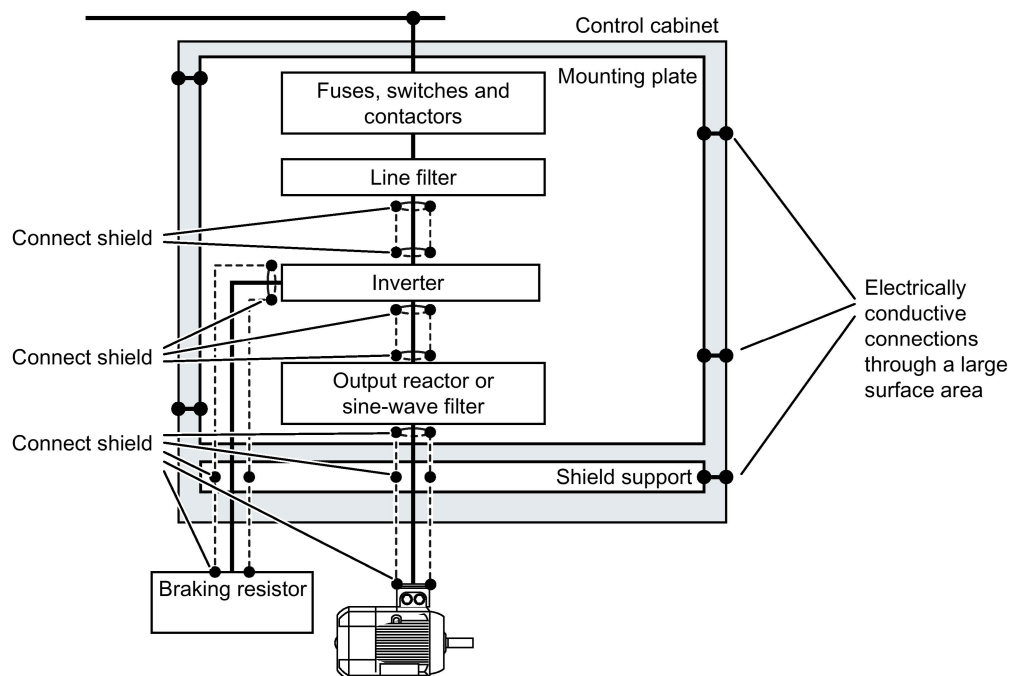

Figure 3-3 Routing inverter cables inside and outside a control cabinet

Routing cables outside the control cabinet

- Maintain a minimum clearance of 25 cm between cables with a high level of interference and cables with a low level of interference.
- Using shielded cables for the following connections:
 - Inverter motor cable
 - Cable between the inverter and braking resistor
 - Signal and data cables
- Connect the motor cable shield to the motor enclosure using a PG gland that establishes a good electrical connection.

Requirements relating to shielded cables

- Use cables with finely-stranded, braided shields.
- Connect the shield to at least one end of the cable.

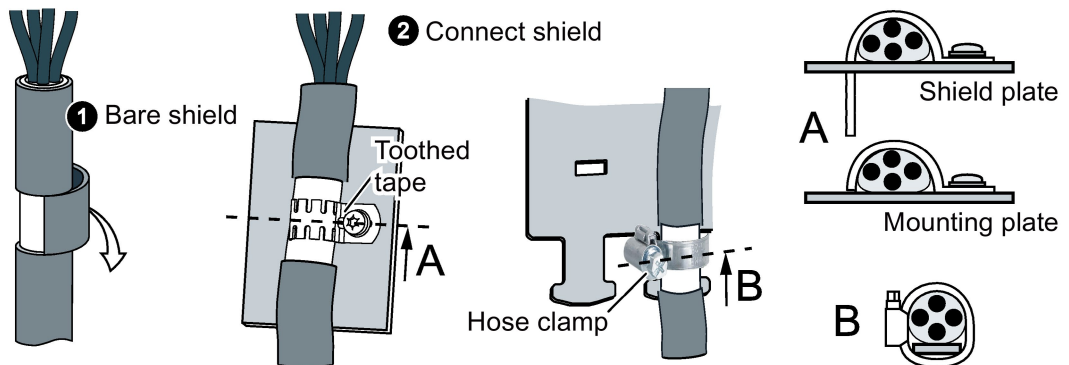

Figure 3-4 Examples for EMC-compliant shield support

- Attach the shield to the shield support directly after the cable enters the cabinet.
- Do not interrupt the shield.
- Only use metallic or metallized plug connectors for shielded data cables.

3.2.3 Electromechanical components

Surge voltage protection circuit

- Connect surge voltage protection circuits to the following components:
 - Coils of contactors
 - Relays
 - Solenoid valves
 - Motor holding brakes
- Connect the surge voltage protection circuit directly at the coil.
- Use RC elements or varistors for AC-operated coils and freewheeling diodes or varistors for DC-operated coils.

3.3 Power losses and air cooling requirements

Cooling requirements

To protect the components from overheating, the control cabinet requires a cooling air flow, which depends on the power loss of the individual components.

Formula for calculating the cooling airflow:

$$\text{airflow [l/s]} = \text{power loss [W]} * 0.86 / \Delta T [K]$$

- Power loss: Total of the power losses of the individual components.
- ΔT : Permissible temperature rise in the control cabinet

Measures in order to ensure that the components are adequately cooled

- Add the power losses of the individual components.
 - Power Module data:  "Technical data (Page 79)".
 - The Control Unit power loss is less than 0.04 kW.
 - Use the manufacturers data for components, for example reactors or filters
- Calculate the air flow required, using the formula above.
- Ensure that the control cabinet is appropriately ventilated and equipped with suitable air filters.
- Ensure that the components maintain the specified clearances with respect to one another.

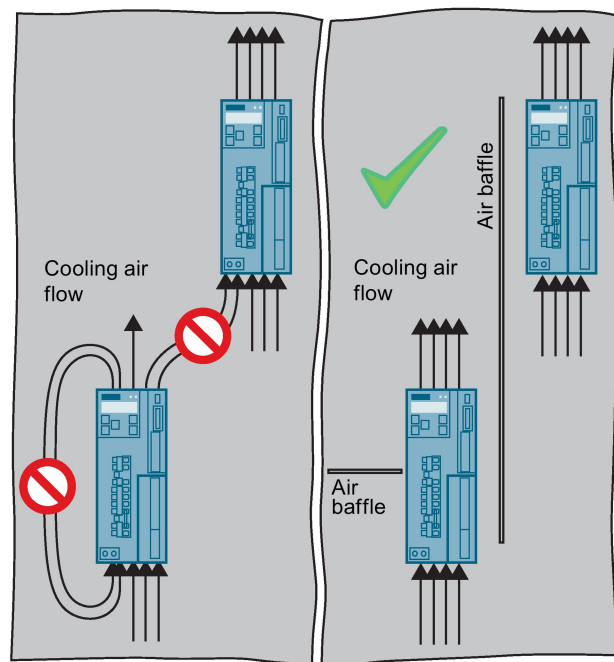

- Ensure that the components are provided with adequate cooling air through the cooling openings.
- Use the appropriate air barriers to prevent cooling air short circuits

Power loss for Power Modules with push-through technology - PT devices

When you use PT Power Modules, the majority of the power loss is dissipated through the heatsink located outside the control cabinet.

3.4 Mounting the Power Modules

Take note of the following listed specifications when installing the Power Module.

Protection against the spread of fire

The device may be operated only in closed housings or in control cabinets with protective covers that are closed, and when all of the protective devices are used. The installation of the device in a metal control cabinet or the protection with another equivalent measure must prevent the spread of fire and emissions outside the control cabinet.

Protection against condensation or electrically conductive contamination

Protect the device, e.g. by installing it in a control cabinet with degree of protection IP54 according to IEC 60529 or NEMA 12. Further measures may be necessary for particularly critical operating conditions.

If condensation or conductive pollution can be excluded at the installation site, a lower degree of control cabinet protection may be permitted.

Installing

| |
|--|
| NOTICE |
| Overheating due to inadmissible mounting |
| If mounted in an inadmissible fashion, the Power Module can overheat and therefore be damaged. |
| <ul style="list-style-type: none">• Follow the mounting instructions. |

Rules for admissible mounting:

- Only mount the Power Module in a vertical position with the motor connectors at the bottom.

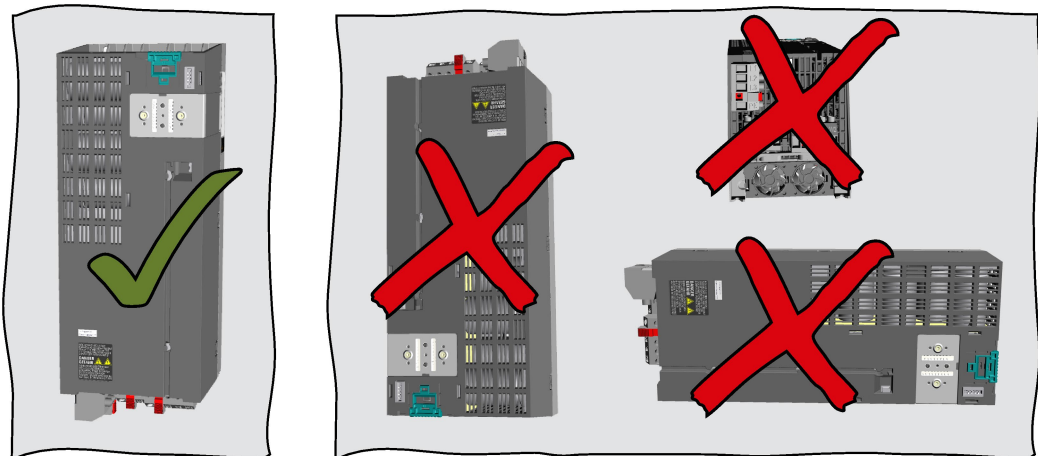

- Maintain the minimum clearances to other components.

- Use the specified installation parts and components.
- Comply with the specified torques.

3.4.1 Sequence for installing the Power Module

During installation, comply with the sequence listed below.

Frame sizes FSA ... FSC

1. Prepare the cabinet.
2. Mount the shield plates.
3. Install the Power Module.
4. If you are using a Brake Relay or Safe Brake Relay:
Install the Brake Relay next to the inverter.

Frame sizes FSD ... FSG

1. Prepare the cabinet.
2. If you are using a Brake Relay or Safe Brake Relay:
Install the Brake Relay on the rear side of the shield plate.
3. Mount the shield plates.
4. Install the Power Module.

3.4.2 Dimension drawings and drilling dimensions for built-in units - IP20 devices

The following dimension drawings and drilling patterns are not to scale.

Frame sizes FSA ... FSC

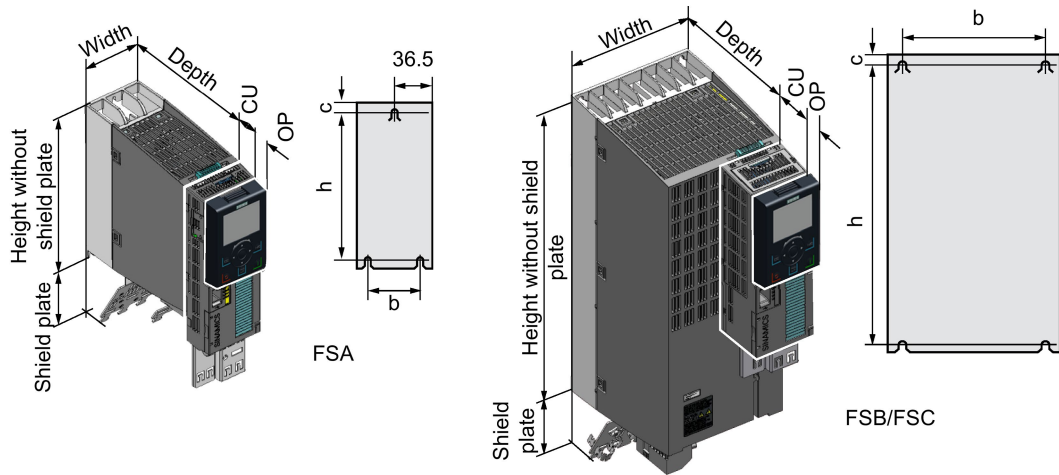

Table 3- 1 Dimensions depend on the Control Unit (CU) and HMI device [mm]

| Frame size | Width [mm] | Height [mm] | | Depth [mm] | | | |
|------------|------------|----------------------|-------------------|------------|-----------------------------|--|-----------------------------|
| | | without shield plate | with shield plate | without CU | with CU230P-2 ¹⁾ | with CU240B-2 ¹⁾ / CU240E-2 ¹⁾ | with CU250S-2 ¹⁾ |
| FSA | 73 | 196 | 276 | 165 | 224 | 206 | 227 |
| FSB | 100 | 292 | 370 | 165 | 224 | 206 | 227 |
| FSC | 140 | 355 | 432 | 165 | 224 | 206 | 227 |

¹⁾ With a Smart Access Module plus 9 mm
With blanking cover or with Operator Panel plus 11 mm.

Table 3- 2 Drilling dimensions, cooling clearances and fixing

| Frame size | Drilling dimensions [mm] | | | Cooling air clearances [mm] ¹⁾ | | | Fixing/torque [Nm] |
|------------|--------------------------|------|---|---|--------|-------|--------------------|
| | h | b | c | Top | Bottom | Front | |
| FSA | 186 | 62.3 | 6 | 80 | 100 | 100 | 3 x M4 / 2.5 |
| FSB | 281 | 80 | 6 | 80 | 100 | 100 | 4 x M4 / 2.5 |
| FSC | 343 | 120 | 6 | 80 | 100 | 100 | 4 x M5 / 3.5 |

¹⁾ The Power Module is designed for mounting without any lateral cooling air clearance. For tolerance reasons, we recommend a lateral clearance of approx. 1 mm.

Frame sizes FSD ... FSG

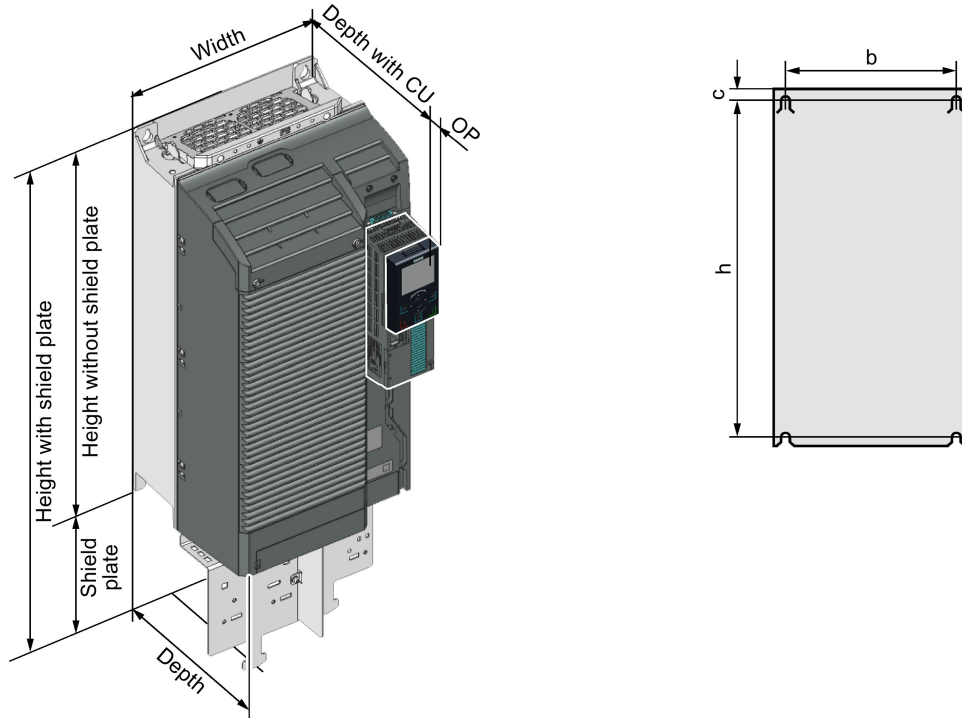

Table 3- 3 Dimensions depend on the Control Unit (CU) and HMI device [mm]

| Frame size | Width [mm] | Height [mm] | | Depth [mm] | | | |
|------------|------------|----------------------|-------------------|------------|-----------------------------|--|-----------------------------|
| | | without shield plate | with shield plate | without CU | with CU230P-2 ¹⁾ | with CU240B-2 ¹⁾ / CU240E-2 ¹⁾ | with CU250S-2 ¹⁾ |
| FSD | 200 | 472 | 624 | 237 | 253 | 237 | 256 |
| FSE | 275 | 551 | 728 | 237 | 253 | 237 | 256 |
| FSF | 305 | 709 | 966 | 357 | 373 | 357 | 376 |
| FSG | 305 | 1000 | 1257 | 357 | 373 | 357 | 376 |

¹⁾ With a Smart Access Module plus 9 mm
 With blanking cover or with Operator Panel plus 11 mm.

Table 3- 4 Drilling dimensions, cooling clearances and fixing

| Frame size | Drilling dimensions [mm] | | | Cooling air clearances [mm] ¹⁾ | | | Fixing/torque [Nm] |
|------------|--------------------------|-----|-----|---|----------------------|-------|--------------------|
| | h | b | c | Top ²⁾ | Bottom ²⁾ | Front | |
| FSD | 430 | 170 | 7 | 300 | 350 | 100 | 4 x M5 / 6.0 |
| FSE | 509 | 230 | 8.5 | 300 | 350 | 100 | 4 x M6 / 10 |
| FSF | 680 | 270 | 13 | 300 | 350 | 100 | 4 x M8 / 25 |
| FSG | 970.5 | 265 | 15 | 300 | 350 | 100 | 4 x M10 / 50 |

1) The Power Module is designed for mounting without any lateral cooling air clearance. For tolerance reasons, we recommend a lateral clearance of approx. 1 mm.

2) The top and bottom cooling air clearances refer to the Power Module without shield plate

3.4.3 Dimension drawings and drilling dimensions for PT Power Modules

Use the optional mounting frame to mount a Power Module in push-through technology in a control cabinet. The mounting frame includes the necessary seals and frame to ensure compliance with degree of protection IP55.

If you do not use the optional mounting frame, then you must ensure that the required degree of protection is complied with using other appropriate measures. Mounting instructions are provided in the following section:

 Mounting frames for PT power modules (Page 129)

The following dimension drawings and drilling patterns are not to scale.

Frame sizes FSA ... FSC

Wall thickness of the control cabinet ≤ 3.5 mm

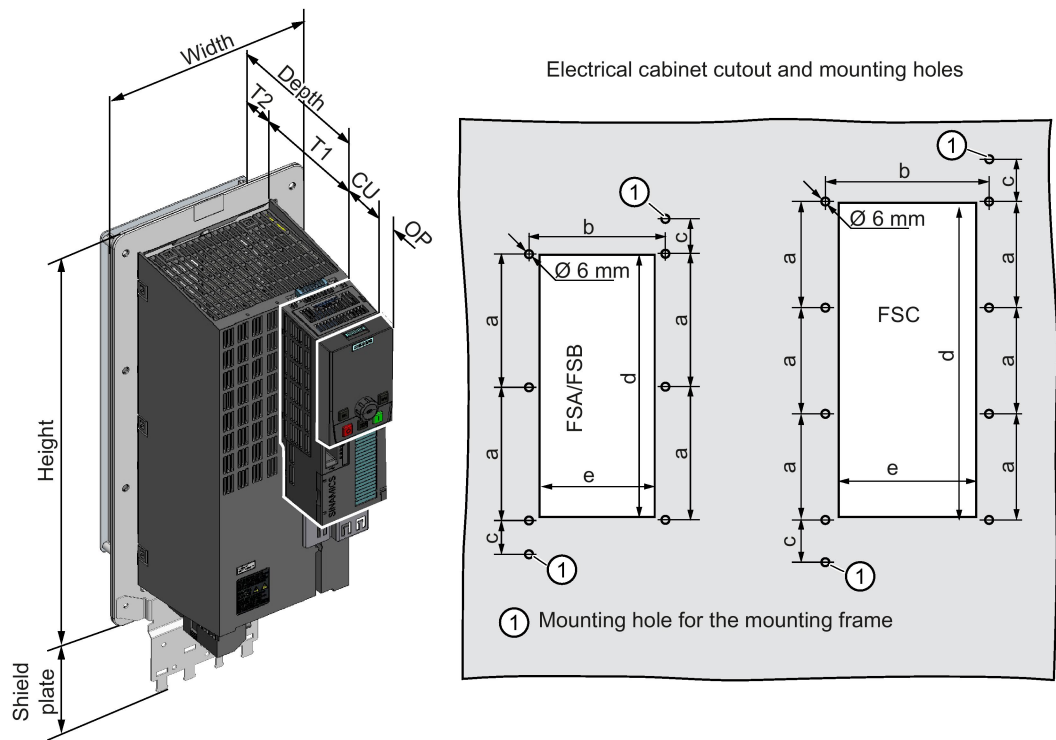

Figure 3-5 Dimension drawing and drilling dimensions for frame sizes FSA ... FSC

Table 3- 5 Dimensions depend on the Control Unit (CU) and HMI device [mm]

| Frame size | Width [mm] | Height [mm] | | Overall depth in the cabinet [mm] | | | |
|------------|------------|----------------------|-------------------|-----------------------------------|-----------------------------|--|-----------------------------|
| | | Without shield plate | With shield plate | T1 | with CU230P-2 ¹⁾ | with CU240B-2 ¹⁾ / CU240E-2 ¹⁾ | with CU250S-2 ¹⁾ |
| FSA | 126 | 238 | 322 | 118 | 177 | 159 | 180 |
| FSB | 154 | 345 | 430 | 118 | 177 | 159 | 180 |
| FSC | 200 | 411 | 500 | 118 | 177 | 159 | 180 |

¹⁾ With a Smart Access Module plus 9 mm
With blanking cover or with Operator Panel plus 11 mm.

Table 3- 6 Cooling air clearances and additional dimensions

| Frame size | Power Module depth [mm] | | | Cooling air clearances [mm] ¹⁾ | | |
|-------------|-------------------------|-----|----|---|--------|-------|
| | T1 + T2 | T1 | T2 | Top | Bottom | Front |
| FSA ... FSC | 171 | 118 | 53 | 80 | 100 | 100 |

¹⁾ The Power Module is designed for mounting without any lateral cooling air clearance. For tolerance reasons, we recommend a lateral clearance of 1 mm.

Table 3- 7 Electrical cabinet cutout and mounting

| Frame size | Control cabinet cutout [mm] | | | | | Fixing/torque [Nm] |
|------------|-----------------------------|-----|------|-----|-----|--------------------|
| | a | b | c | d | e | |
| FSA | 103 | 106 | 27 | 198 | 88 | 8 × M5 / 3.5 |
| FSB | 148 | 134 | 34.5 | 304 | 116 | 8 × M5 / 3.5 |
| FSC | 123 | 174 | 30.5 | 365 | 156 | 10 × M5 / 3.5 |

Frame sizes FSD ... FSF

Wall thickness of the control cabinet ≤ 3.5 mm

Cutouts of the control cabinet and mounting holes

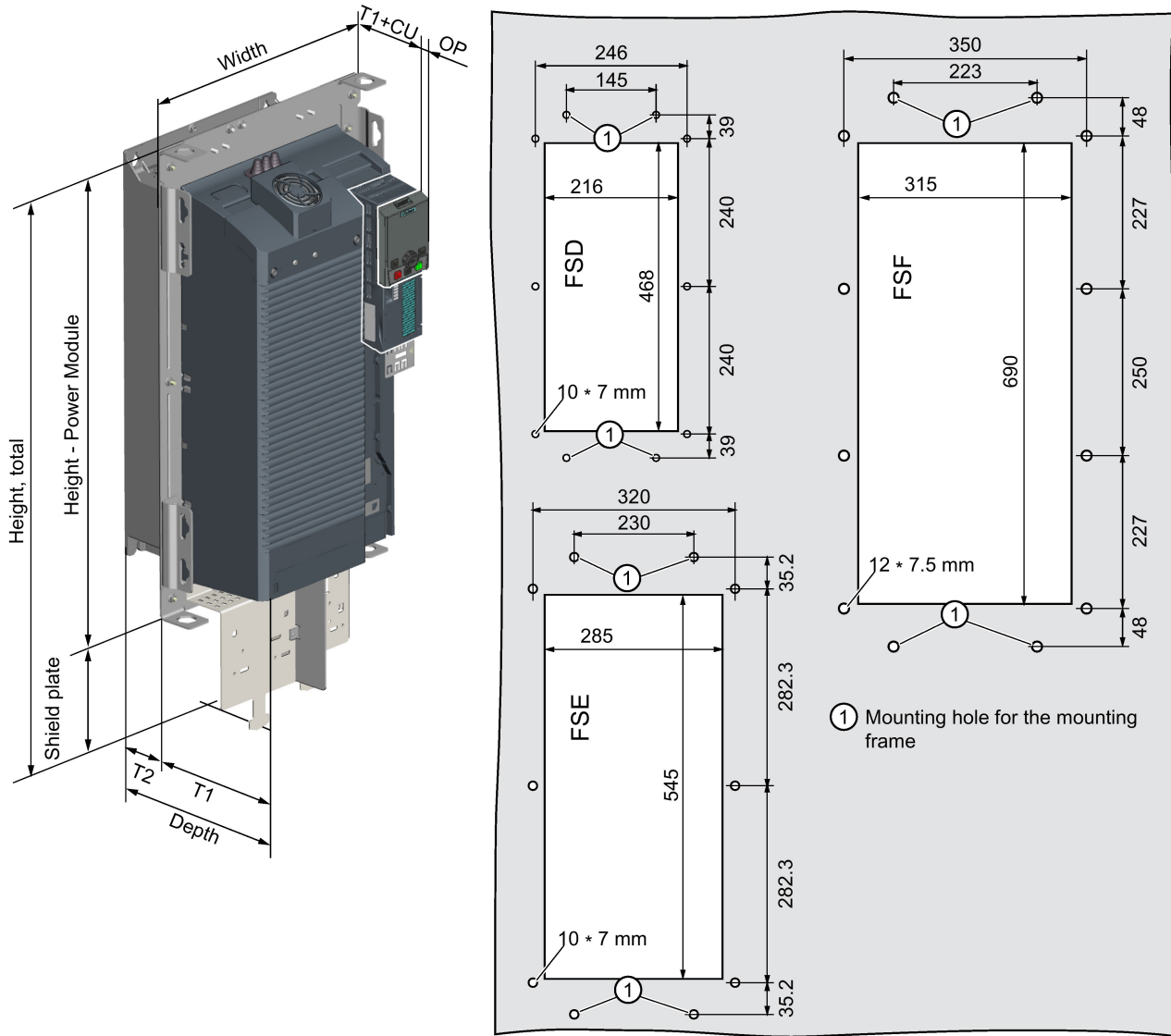

Figure 3-6 Dimension drawing and drilling dimensions for frame sizes FSD ... FSF

Table 3- 8 Dimensions depend on the Control Unit (CU) and HMI device [mm]

| Frame size | Width [mm] | Height [mm] | | Overall depth in the cabinet [mm] | | | |
|------------|------------|----------------------|-------------------|-----------------------------------|-----------------------------|--|-----------------------------|
| | | Without shield plate | With shield plate | T1 | with CU230P-2 ¹⁾ | with CU240B-2 ¹⁾ / CU240E-2 ¹⁾ | with CU250S-2 ¹⁾ |
| FSD | 275 | 517 | 650 | 141 | 155 | 141 | 158 |
| FSE | 354 | 615 | 772 | 141 | 155 | 141 | 158 |
| FSF | 384 | 785 | 1021 | 177.5 | 193 | 177.5 | 196 |

¹⁾ With a Smart Access Module plus 9 mm
With blanking cover or with Operator Panel plus 11 mm.

Table 3- 9 Cooling air clearances, further dimensions and mounting

| Frame size | Power Module depth [mm] | | | Cooling air clearances [mm] | | | Fixing/torque [Nm] |
|------------|-------------------------|-------|-------|-----------------------------|--------|-------|--------------------|
| | T1 + T2 | T1 | T2 | Top | Bottom | Front | |
| FSD | 238.5 | 141 | 97.5 | 350 | 300 | 100 | 10 × M5 / 3.5 |
| FSE | 238.5 | 141 | 97.5 | 350 | 300 | 100 | 10 × M5 / 3.5 |
| FSF | 358 | 177.5 | 180.5 | 350 | 300 | 100 | 12 × M6 / 5.9 |

3.4.4 Mounting the shield plates

Use the provided shield plate for strain relief of the line and motor cable – as well as the shield support for the motor cable.

3.4.5 Mounting the shield plate, FSA ... FSC

The shield plates and fixings screws are included in the inverter accessory kit.

Mounting the shield plate, FSA ... FSC - Built-in devices

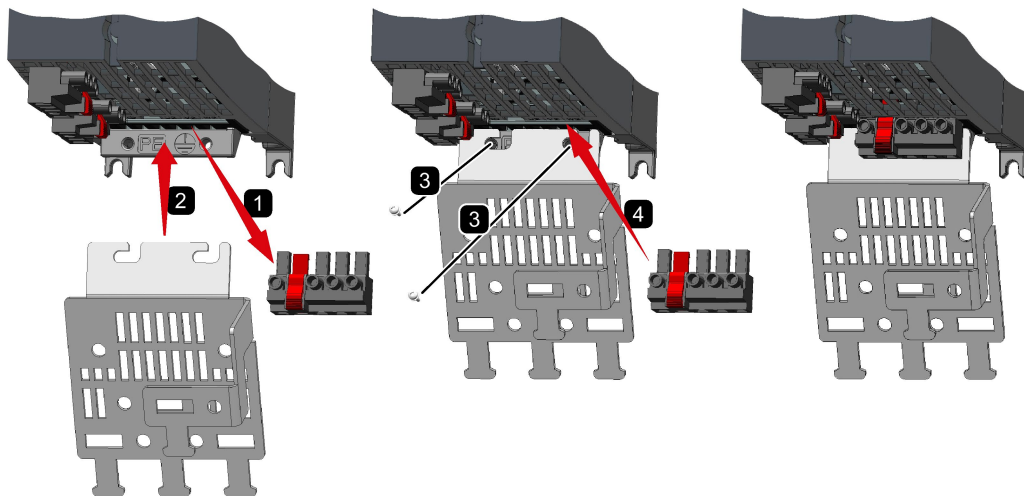

Mounting the shield plate, FSA ... FSC - PT Power Module

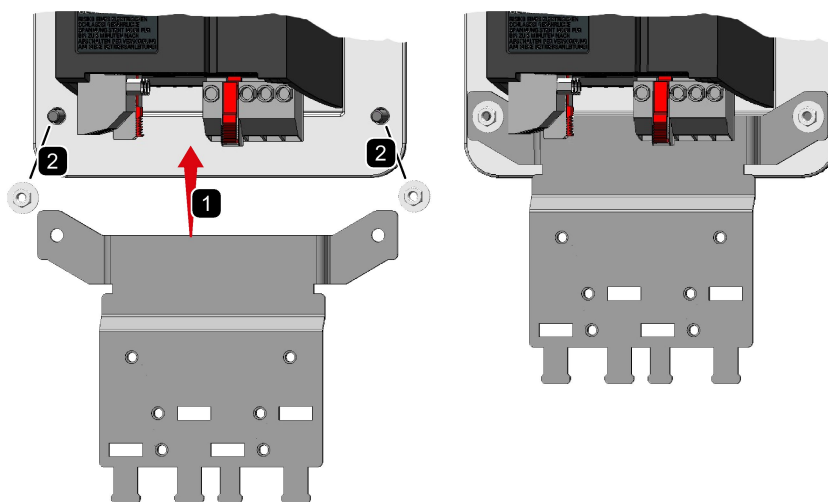

3.4.6 Mounting the shield plate, FSD ... FSG

Note

Built-in devices and PT Power Modules

The shield plates are mounted in the same way for PT and IP20 devices.

Upper shield plate

The top shield plate is not supplied with the inverter. You need it as a shield support when you connect an external braking resistor.



Braking resistor (Page 139)

EMC connecting bracket

The EMC connecting bracket is only supplied with inverters with integrated filter.

Mounting the shield plate, FSD and FSE

Procedure



1. Proceed as follows to mount the shield plate:

- If you are using a Brake Relay to control a motor holding brake, then mount the Brake Relay at the rear of the shield plate.



Mounting and connecting the brake relay (Page 149)

- **If the device has an integrated line filter:**

Fasten the EMC connecting bracket to the shield plate using four screws ①.

Then slide the shield plate with the EMC connecting bracket into the inverter, so that it is held in the inverter by the clamping spring ②.

The EMC connecting bracket is positioned correctly if there is some resistance when it is withdrawn from the inverter.

Having ensured that it is positioned correctly, fasten the shield plate in place using the four screws ③.

- **If the device is unfiltered:**

Having ensured that it is positioned correctly, fasten the shield plate in place using the four screws ③.

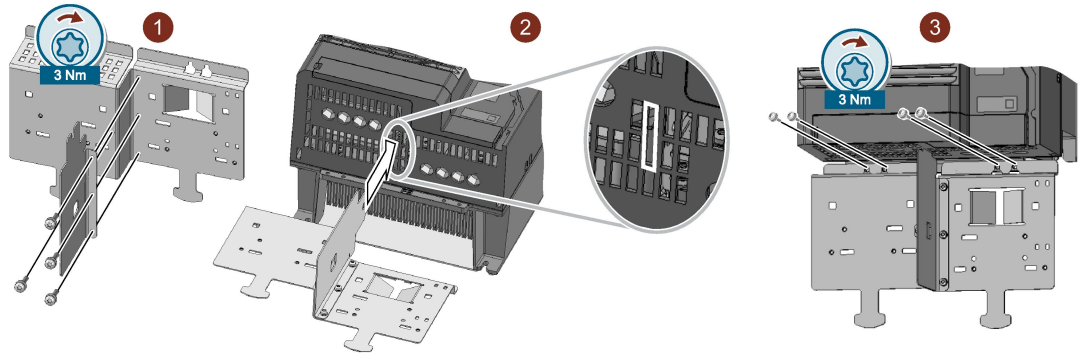

■ You have mounted the shield plate.

Mounting the shield plate, FSF

Procedure



1. Proceed as follows to mount the shield plate:

- If you are using a Brake Relay to control a motor holding brake, then mount the Brake Relay at the rear of the shield plate.



Mounting and connecting the brake relay (Page 149)

- **If the device has an integrated line filter:**

Fasten the EMC connecting bracket to the shield plate with four screws ①.

- Screw the shield plate to the inverter together with the EMC connecting bracket using three screws ②

- **If the device is unfiltered:**

Having ensured that it is positioned correctly, fasten the shield plate in place using the four screws ②.

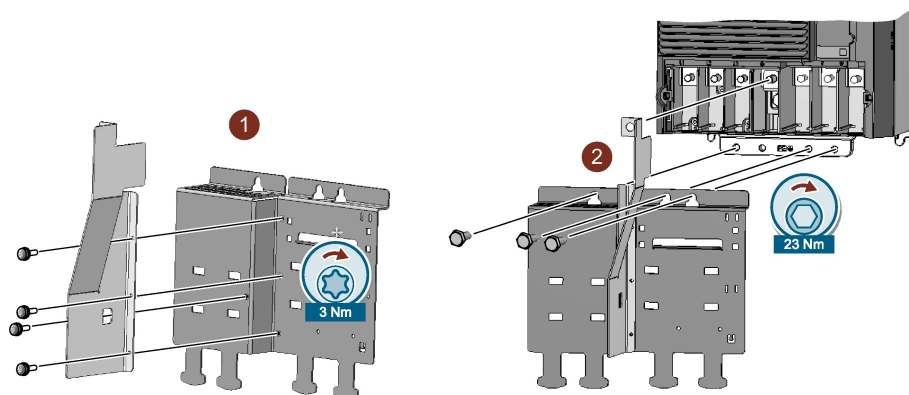

■ You have mounted the shield plate.

Mounting the shield plate, FSG

Procedure

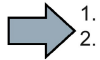

Proceed as follows to mount the shield plate:

- If you are using a Brake Relay to control a motor holding brake, then mount the Brake Relay at the rear of the shield plate.



Mounting and connecting the brake relay (Page 149)

- Secure each side part to the shield plate with two screws ①.
- Fasten the EMC connecting bracket to the shield plate with four screws ②.
- Screw the shield plate to the inverter together with the side parts and EMC connecting bracket using four screws ③

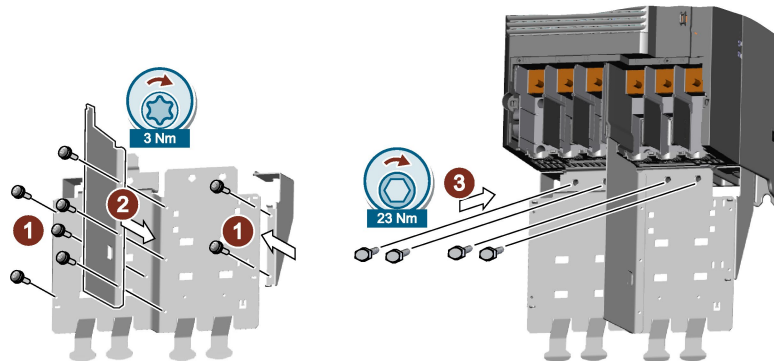

You have mounted the shield plate.

3.4.7 Hoisting gear FSD ... FSG

Power Module weights:

 200 V inverter (Page 89)

 400 V inverter (Page 100)

 690 V inverter (Page 112)

Hoisting gear - Built-in devices

Use crane lifting lugs and the appropriate hoisting gear when mounting built-in devices.

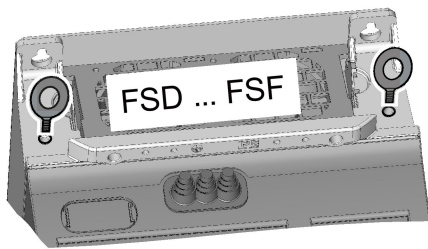

Hoisting gear - PT devices

Use the hoisting gear shown below when mounting the Power Modules

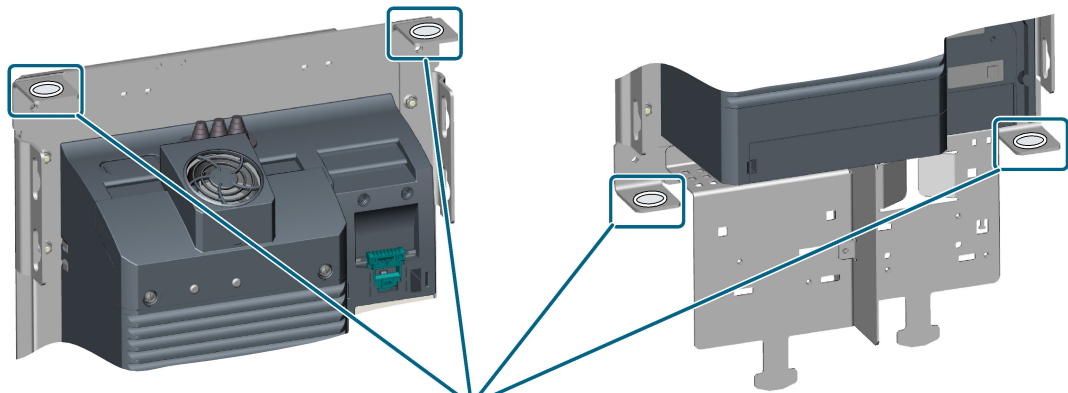

Hoisting gear for PT Power Modules
FSD ... FSF

Alternatively, you have the option of attaching mounting grips onto the Power Module.

 Mounting grips for PT Power Modules (Page 133).

3.4.8 Additional components

Depending on the particular application, additional components may be required for your system. Information about additional components is provided in the following Sections:

 Connection overview (Page 56)

 Accessories (Page 127).

Connecting-up

Install the converter so that you are compliant with local regulations for erecting and installing low-voltage systems.

Note

Safety devices

Install suitable protective equipment between the line supply and converter.



Technical data (Page 79)

Note

Operating displays for converter operation

If, when switching over a function from ON to OFF, an LED or other similar display is not lit or not active; this does not indicate that the device is switched-off or in a no-current condition.

Observe the following product note about protection against indirect contact:

To protect against indirectly touching part of the motor circuit of an inverter and to automatically shut down in the case of a fault according to DIN EN 60364-4-41 (VDE 0100-410). (<http://support.automation.siemens.com/WW/view/en/103474630>)

 **WARNING**

Electric shock due to faulty contact protection

Due to faulty contact protection, the power connections of the inverter may be openly accessible. Touching live power connections can result in death or severe injury.

- Make the openings for the inverter power connections just large enough for the cables to be routed through.
- Cover power connections that are not used so that they cannot be touched.
- Use the dummy plugs provided in the accessory pack for unused terminals.

Note

Fault of the wireless services caused by high-frequency faults in residential environments

In a residential environment this product can cause high-frequency interference, which may make interference suppression measures necessary.

- Have qualified personnel carry out the installation and commissioning with suitable interference suppression measures.
-

 **WARNING**

Fire or electric shock due to unsuitable residual-current protective devices

The inverter may create a current through the protective conductor. The current through the protective conductor can cause the residual current device (RCD) or residual current monitor (RCM) to incorrectly trip (nuisance trip). In the case of a ground fault, the fault current can contain a DC component, which prevents the RCD or RCM from tripping, with the risk of subsequent fire or electric shock.

- Use the protection and monitoring devices recommended in the documentation.



! CAUTION

Burns due to touching hot surfaces

Certain components (e.g. the heat sink or line reactor) can become very hot during operation. The components can remain hot for some time after operation. Touching hot surfaces can cause burns to the skin.

- Do not touch hot components during operation or immediately following operation.

Protection and monitoring equipment

To provide protection against short-circuit, use the overcurrent devices listed in Technical data (fuses, circuit breakers etc.).

If the apparent impedance of the line supply at the infeed point is not suitable, so that fuses do not rupture in the specified time in the case of insulation failure (ground fault, fault to frame), then you must use additional fault current protective devices RCD (RCCB or MRCD), type B.

In order that an RCD does not unnecessarily trip as a result of operational leakage currents, the following preconditions must be fulfilled:

- The neutral point of the line supply is grounded.
- For inverters with rated input currents ≤ 125 A referred to LO, use an RCCB type B with a response limit current of 300 mA. Connect the RCCB in series with the overcurrent protective devices.

- For inverters with rated input currents > 125 A referred to LO, use a type B MRCD (for example, from the Bender company).
An MRCD comprises an RCM (differential current monitoring device), a measuring current transducer and a circuit breaker with additional undervoltage release, listed in the Technical data. An example of an MRCD design is provided in the following diagram.

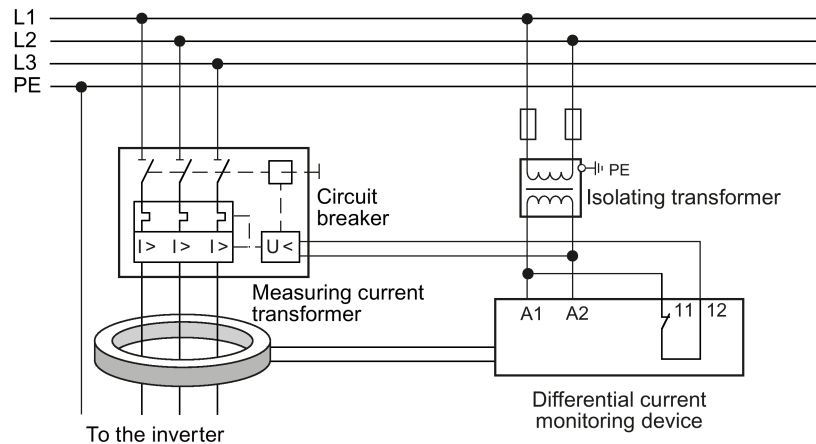

Figure 4-1 MRCD

- A dedicated RCD is used for every inverter.
- The motor cables are shorter than 50 m (164 ft) shielded, or 100 m (328 ft) unshielded.
Additional information about motor cables
➡ Length of the motor cable (Page 60)



Further protection and monitoring equipment

<https://support.industry.siemens.com/cs/ww/en/view/109486009>

4.1 Permissible line supplies

The converter is designed for the following line supplies according to IEC 60364-1 (2005).

- TN system
- TT system
- IT system

General requirements on line supply

The plant builder or machine manufacturer must ensure for operation with rated current I_{rated} that the voltage drop between the transformer input terminals and the inverter when operated with its rated values is less than 4% of the transformer rated current

Restrictions for installation altitudes above 2000 m

Above an installation altitude of 2000 m, the permissible line supplies are restricted.

 Restrictions for special ambient conditions (Page 116)

Screw for functional grounding on the converter, frame size FSG

If you wish to use the inverters with integrated C3 line filter, please note the information in the sections "TN line system", "TT line system" and "IT system" below.

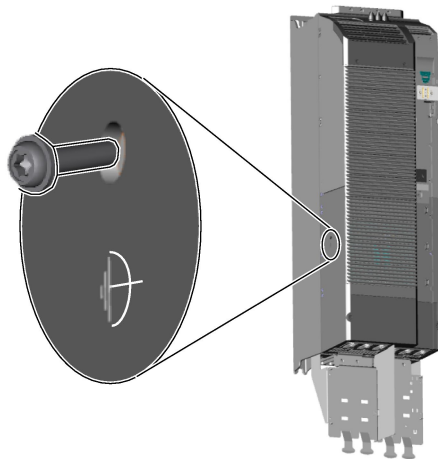

Figure 4-2 Remove screw for functional grounding

4.1.1 TN line system

A TN line system transfers the PE protective conductor to the installed plant or system using a cable.

Generally, in a TN line system the neutral point is grounded. There are versions of a TN system with a grounded line conductor, e.g. with grounded L1.

A TN line system can transfer the neutral conductor N and the PE protective conductor either separately or combined.

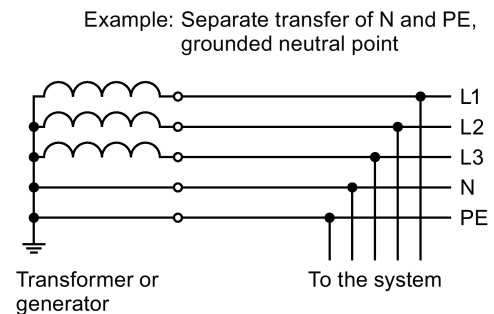

Inverter connected to a TN system

- Inverters with integrated line filter:
 - Operation on TN line systems with grounded neutral point permissible.
 - Operation on TN line systems with grounded line conductor not permissible.

Note

Special feature of FSG inverters

FSG inverters with integrated C3 line filter can be operated in TN line systems ≤ 600 V with a grounded line conductor if you remove the screw for functional grounding.



Figure 4-2 Remove screw for functional grounding (Page 50)

If you remove the screw for functional grounding, the EMC properties deteriorate and the requirements of Class C3 are no longer met.

- Inverters with external line filter:
 - Operation on TN line systems with grounded neutral point permissible.
 - Operation on TN line systems with grounded line conductor not permissible.
- Inverter without line filter:
 - Operation on all TN line systems ≤ 600 V permissible
 - Operation on TN line systems > 600 V and grounded neutral point permissible.
 - Operation on TN line systems > 600 V and grounded line conductor not permissible.

4.1.2 TT line system

In a TT line system, the transformer grounding and the installation grounding are independent of one another.

There are TT line supplies where the neutral conductor N is either transferred – or not.

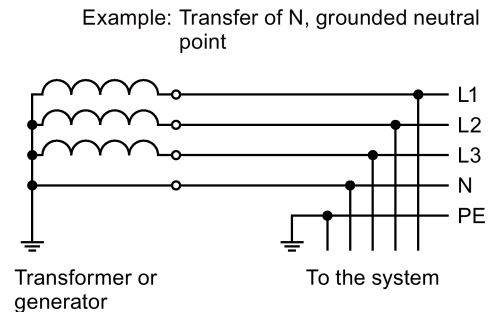

Note

Operation in IEC or UL systems

For installations in compliance with IEC, operation on TT line systems is permissible. For installations in compliance with UL, operation on TT line systems is not permissible.

Inverter connected to a TT system

- Inverters with integrated line filter:
 - Operation on TT line systems with grounded neutral point permissible.
 - Operation on TT line systems without grounded neutral point not permissible.

Note

Special feature of FSG inverters

FSG inverters with integrated C3 line filter can be operated in TT line systems without a grounded neutral point if you remove the screw for functional grounding.

 Figure 4-2 Remove screw for functional grounding (Page 50)

If you remove the screw for functional grounding, the EMC properties deteriorate and the requirements of Class C3 are no longer met.

- Inverters with external line filter:
 - Operation on TT line systems with grounded neutral point permissible.
 - Operation on TT line systems without grounded neutral point not permissible.
- Inverter without line filter:
 - Operation on all TT line systems permissible.

4.1.3 IT system

In an IT line system, all of the conductors are insulated with respect to the PE protective conductor – or connected to the PE protective conductor through an impedance.

There are IT systems with and without transfer of the neutral conductor N.

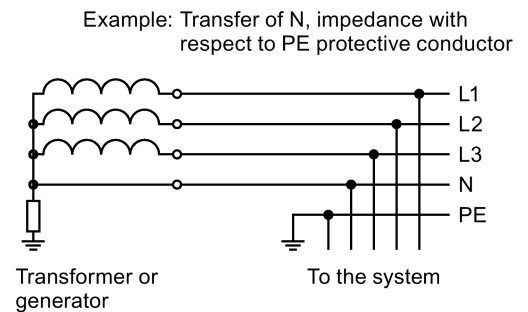

Note

Behavior of the inverter when a ground fault occurs

If the inverter is to remain operable even when a ground fault occurs at the inverter output, you must install an output reactor. This prevents an overcurrent trip or damage to the drive.

Inverter connected to an IT system

- Inverters with integrated line filter:
 - Operation on IT line systems not permissible.

Note

Special feature of FSG inverters

FSG inverters with integrated C3 line filter can be operated in IT line systems if you remove the screw for functional grounding.



Figure 4-2 Remove screw for functional grounding (Page 50)

If you remove the screw for functional grounding, the EMC properties deteriorate and the requirements of Class C3 are no longer met.

- Inverter without line filter:
 - Operation on all IT line systems permissible.

Note

690 V inverters: Output reactors for frame sizes FSD and FSE

An output reactor is required for 690 V reactors in frame sizes FSD and FSE.

4.1.4 Protective conductor



| |
|--|
| <p>! WARNING</p> <p>Electric shock due to interrupted protective conductor</p> <p>The drive components conduct a high leakage current via the protective conductor. Touching conductive parts when the protective conductor is interrupted can result in death or serious injury.</p> <ul style="list-style-type: none"> • Dimension the protective conductor as stipulated in the appropriate regulations. |
|--|

Dimensioning the protective conductor

Observe the local regulations for protective conductors subject to an increased leakage current at the site of operation.

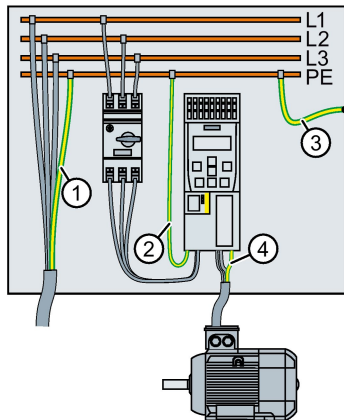

- ① Protective conductor for line feeder cables
- ② Protective conductor for inverter line feeder cables
- ③ Protective conductor between PE and the control cabinet
- ④ Protective conductor for motor feeder cables

The minimum cross-section of the protective conductor ① ... ④ depends on the cross-section of the line or motor feeder cable:

- Line or motor feeder cable $\leq 16 \text{ mm}^2$
 - ⇒ Minimum cross-section of the protective conductor = cross-section of the line or motor feeder cable
- $16 \text{ mm}^2 < \text{line or motor feeder cable} \leq 35 \text{ mm}^2$
 - ⇒ Minimum cross-section of the protective conductor = 16 mm^2
- Line or motor feeder cable $> 35 \text{ mm}^2$
 - ⇒ Minimum cross-section of the protective conductor = $\frac{1}{2}$ cross-section of the line or motor feeder cable

Additional requirements placed on the protective conductor ①:

- For permanent connection, the protective conductor must fulfill at least one of the following conditions:
 - The protective conductor is routed so that it is protected against damage along its complete length.
Cables routed inside switch cabinets or enclosed machine housings are considered to be adequately protected against mechanical damage.
 - As a conductor of a multi-conductor cable, the protective conductor has a cross-section $\geq 2.5 \text{ mm}^2 \text{ Cu}$.
 - For an individual conductor, the protective conductor has a cross-section $\geq 10 \text{ mm}^2 \text{ Cu}$.
 - The protective conductor consists of two individual conductors with the same cross-section.
- When connecting a multi-core cable using an industrial plug connector according to EN 60309, the protective conductor must have a cross-section of $\geq 2.5 \text{ mm}^2 \text{ Cu}$.

4.2 Connecting the line and motor cable at the inverter

4.2.1 Connection overview

Note

Line reactor

No line reactor is required for FSD ... FSG Power Modules.

Line filter

The inverters are available with or without integrated line filter (Class A). For frame sizes FSA ... FSC, 3 AC 400 V, there are external filters (Class B) for increased EMC requirements.  Line filter (Page 137)

Output reactor

For frame sizes FSD ... FSG no output reactor is required in many cases on account of the long cable lengths between the inverter and the motor.

Available output reactors:

 Output reactor (Page 150)

Braking resistor

Connect a braking resistor to the inverter via the R1 and R2 terminals.

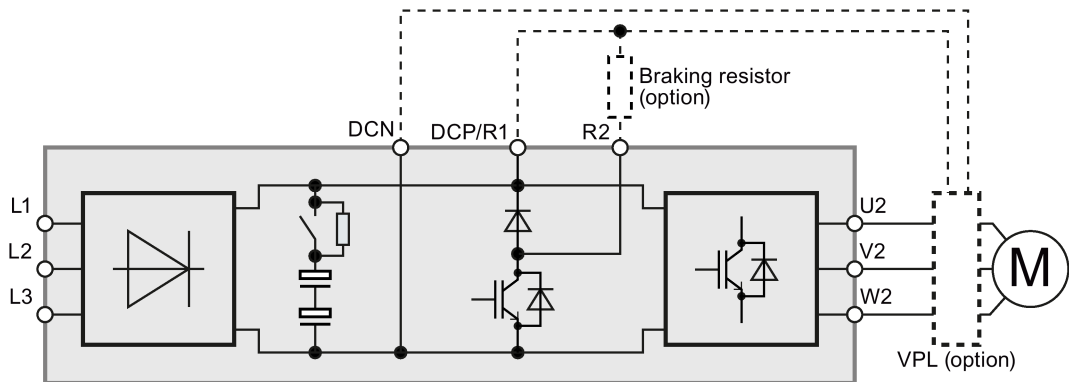

Figure 4-3 Block diagram of the inverter, FSA ... FSC

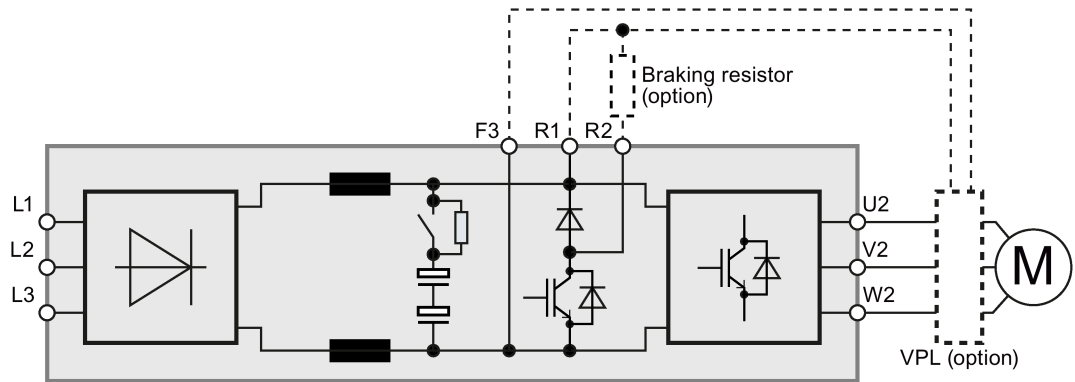

Figure 4-4 Block diagram for the inverter, FSD ... FSG

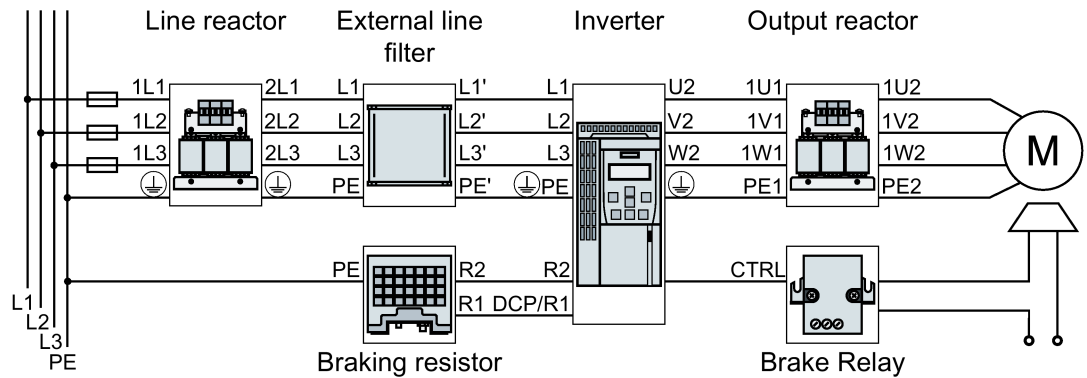

Figure 4-5 Connecting the PM240-2 Power Module, 200 V / 400 V 3 AC, FSA ... FSC

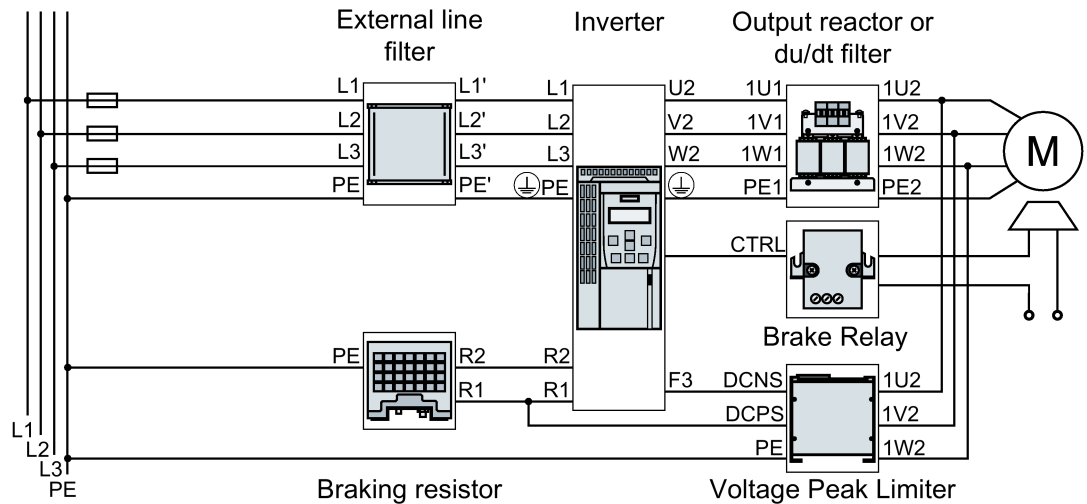

Figure 4-6 Connecting the PM240-2 Power Module, 200 V / 400 V / 690 V 3 AC, FSD ... FSG

4.2 Connecting the line and motor cable at the inverter

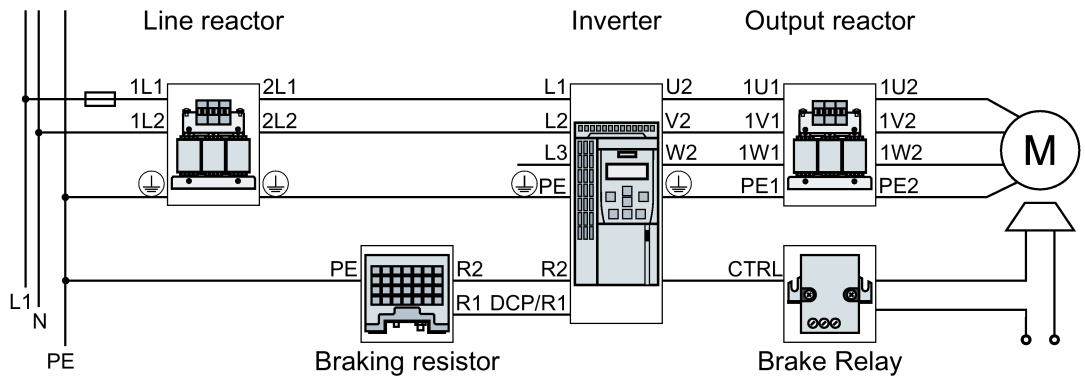

Figure 4-7 Connecting the PM240-2 Power Module, 200 V 1 AC, FSA ... FSC

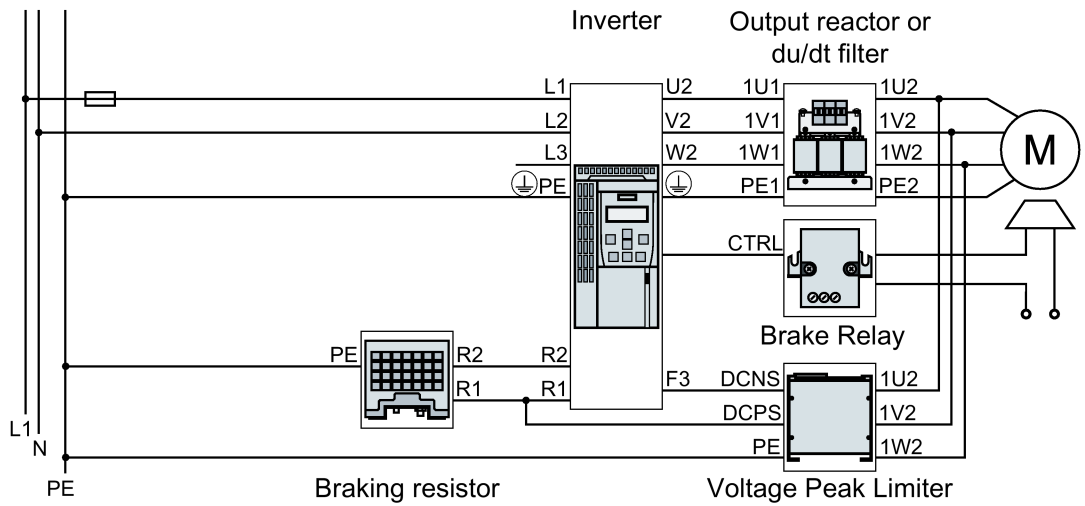

Figure 4-8 Connecting the PM240-2 Power Module, 200 V 1 AC, FSD ... FSF

Note

Connecting PM240-2 Power Modules, 200 V to 1 AC - only FSA ... FSC

For the 200 V versions and single-phase line systems, connect the phase conductor and neutral conductor to any two of the terminals L1, L2, L3.

Connect cables at the inverter so that they are EMC compliant

Attach the cable tie holders to the Power Module as shown to the left in the diagram before you establish the connections.

Fix the line connecting cable using a cable tie as shown in ①.

Fix the shield of the motor connecting cable using a hose clamp (②).

Connect the shield of the control cable with the shield plate of the Control Unit (③) using a steel band. Also attach the control cable to the Power Module using a cable tie (④).

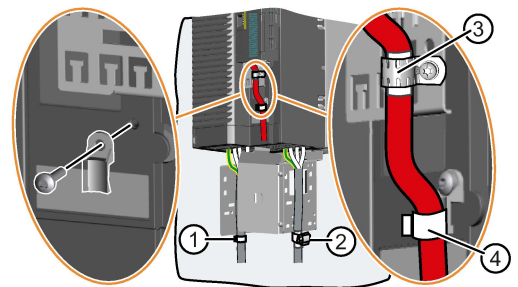

4.2.2 Length of the motor cable

Always dimension the motor cable so that the ohmic losses are less than 5 % of the inverter power rating.

The permissible length of the motor cable also depends on the quality of the motor cable and the inverter pulse frequency. The values specified below are applicable for high quality cables, such as CY100 or similar, and for the pulse frequencies set in the factory.

 Pulse frequencies (Page 79).

If you set other pulse frequencies, then you must ensure that the EMC category is complied with on the plant or system side.

EMC-compliant wiring is required in order that the inverter complies with the EMC category listed in the following table.

 EMC-compliant installation of a machine or system (Page 24)

Carefully observe the following section for operation in the first environment:

 Electromagnetic compatibility of variable-speed drives (Page 119)

Table 4- 1 Permissible lengths of motor connecting cables, inverter FSA ... FSC

| EMC category | Second Environment, C2 | | | No EMC category | | |
|--------------|-------------------------|-------------------------|--|--|-------------------------------------|------------|
| | with internal C2 filter | with external C2 filter | with external C1 filter, with output reactor | without filter, without output reactor | without filter, with output reactor | |
| Cable | Shielded | Shielded | Shielded | Shielded/unshielded | Shielded | Unshielded |
| 200 V | 50 m | 50 m | --- | 150 m | 150 m | 225 m |
| 400 V | 50 m ¹⁾ | 50 m ²⁾ | 150 m ³⁾ | 150 m | 150 m | 225 m |

1) For a low-capacitance motor cable: FSB 100 m, FSC 150 m

2) For a low-capacitance motor cable: FSA 150 m, FSB 100 m, FSC 100 m

3) 150 m for voltages in the range 380 V ... 415 V,
100 m for voltages in the range 440 V ... 480 V

Table 4- 2 Permissible cable lengths for the motor connection, FSD ... FSE

| EMC category | Second Environment, C2 | No EMC category | | | |
|--------------|------------------------|--|------------|--|------------|
| | | with or without filter, with or without output reactor | | without filter, with two output reactors in series | |
| Cable | Shielded | Shielded | Unshielded | Shielded | Unshielded |
| 200 V | 150 m | 200 m | 300 m | 350 m | 525 m |
| 400 V | 150 m | 200 m | 300 m | 350 m | 525 m |
| 690 V | 100 m | 200 m | 300 m | --- | --- |

Table 4- 3 Permissible cable lengths for the motor connection, FSF

| Inverter | with internal C2 filter | with or without filter, with or without output reactor | | without filter, with two output reactors in series | |
|--------------|-------------------------|--|------------|--|------------|
| EMC category | Second Environment, C2 | No EMC category | | | |
| Cable | Shielded | Shielded | Unshielded | Shielded | Unshielded |
| 200 V | 150 m | 300 m | 450 m | 525 m | 800 m |
| 400 V | 150 m | 300 m | 450 m | 525 m | 800 m |
| 690 V | 150 m ¹⁾ | 300 m | 450 m | 525 m | 800 m |

Restriction for PT devices with 400 V: Use a double-shielded cable for the motor connection.

¹⁾ only C3



Table 4- 4 Permissible cable lengths for the motor connection, FSG

| Inverter | with internal C2 filter | with or without filter, with or without output reactor | | without filter, with two output reactors in series | |
|--------------|------------------------------|--|------------|--|------------|
| EMC category | Second Environment, C2 | No EMC category | | | |
| Cable | Shielded | Shielded | Unshielded | Shielded | Unshielded |
| 400 V | 150 m 300 m ¹⁾ | 300 m | 450 m | 525 m | 800 m |
| 690 V | 300 m ¹⁾ | 300 m | 450 m | 525 m | 800 m |

¹⁾ only C3

4.2.3 Connection terminals at the inverter

Table 4- 5 Connection, cross-section and tightening torque for PM240-2 Power Modules

| Inverters | Connection | | Cross-section, tightening torque | | Stripped insulation length |
|------------|---|---|--|--|----------------------------|
| | | | Metric | Imperial | |
| FSA | Line system, motor and braking resistor |  Plug connector with screw terminals | 1.5 ... 2.5 mm ² , 0.5 Nm | 16 ... 14 AWG, 4.5 lbf in | 8 mm |
| FSB | | | 1.5 ... 6 mm ² , 0.6 Nm | 16 ... 10 AWG, 5.5 lbf in | 8 mm |
| FSC | | | 6 ... 16 mm ² , 1.3 Nm | 10 ... 6 AWG, 12 lbf in | 10 mm |
| FSD | Line and motor | Screw-type terminal | 10 ... 35 mm ² , 2.5 ... 4.5 Nm | 20 ... 10 AWG, 22 lbf in 8 ... 2 AWG, 40 lbf in | 18 mm |
| | Braking resistor | | 2.5 ... 16 mm ² , 1.2 ... 1.5 Nm | 20 ... 6 AWG, 15 lbf in | 10 mm |
| FSE | Line and motor | Screw-type terminal | 25 ... 70 mm ² , 8 ... 10 Nm | 6 ... 3/0 AWG, 88.5 lbf in | 25 mm |
| | Braking resistor | | 10 ... 35 mm ² , 2.5 ... 4.5 Nm | 20 ... 10 AWG, 22 lbf in 8 ... 2 AWG, 40 lbf in | 18 mm |
| FSF | Line and motor |  Cable lug according to SN71322 for M10 bolts | 35 ... 2 × 120 mm ² , 22 ... 25 Nm | 1 AWG ... 2 × 4/0 AWG, 210 lbf.in | -- |
| | Braking resistor | Screw-type terminal | 25 ... 70 mm ² , 8 ... 10 Nm | 6 ... 3/0 AWG, 88.5 lbf in | 25 mm |
| FSG | Line and motor |  Cable lug according to SN71322 for M10 bolts | 35 ... 2 × 185 mm ² , 22 ... 25 Nm | 1 AWG ... 2 × 350 MCM, 210 lbf.in | -- |
| | Braking resistor | Screw-type terminal | 25 ... 70 mm ² , 8 ... 10 Nm | 6 ... 3/0 AWG, 88.5 lbf in | 25 mm |

4.2.4 Establishing connections

Procedure

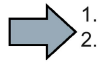

Proceed as follows to establish the connections:

1. Ensure that the device is in a no-voltage condition and the DC link is discharged.
2. Establish the connections as described in the following sections.



This means that you have established the connections.

Connections for frame sizes FSA ... FSC

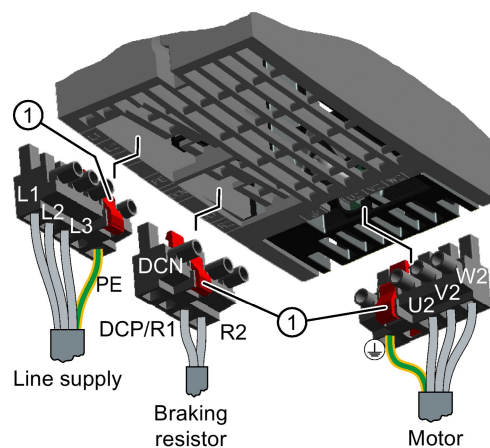

The Power Modules are equipped with withdrawable plug connectors that cannot be inadvertently interchanged.

To remove a plug connector, you must release it by pressing on the red lever.

- ① Release lever

Connections for frame sizes FSD ... FSG

You must remove the covers from the connections in order to connect the line supply, braking resistor and motor to the inverter.

In addition, for frame sizes FSD and FSE, release the two terminal screws on the connections for the motor and braking resistor, and remove the dummy plug.

For frame sizes FSF and FSG, you must breakout the openings from the connection cover for the power connections. Use side cutters or a fine saw blade.

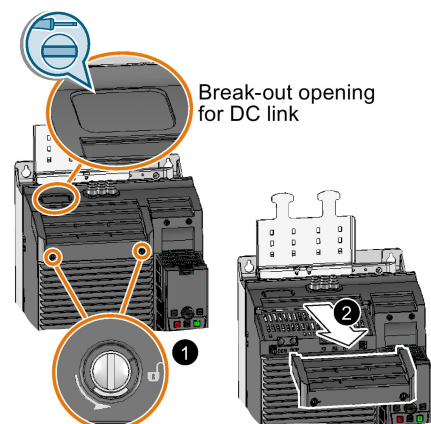

FSD ... FSG: Remove the top covers

4.2 Connecting the line and motor cable at the inverter

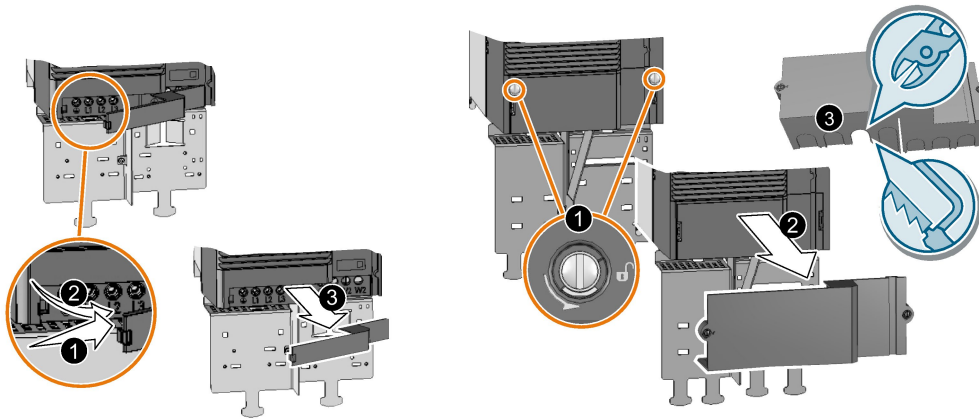

FSD, FSE: Remove the lower cover

FSF, FSG: Remove the lower cover

4.2 Connecting the line and motor cable at the inverter

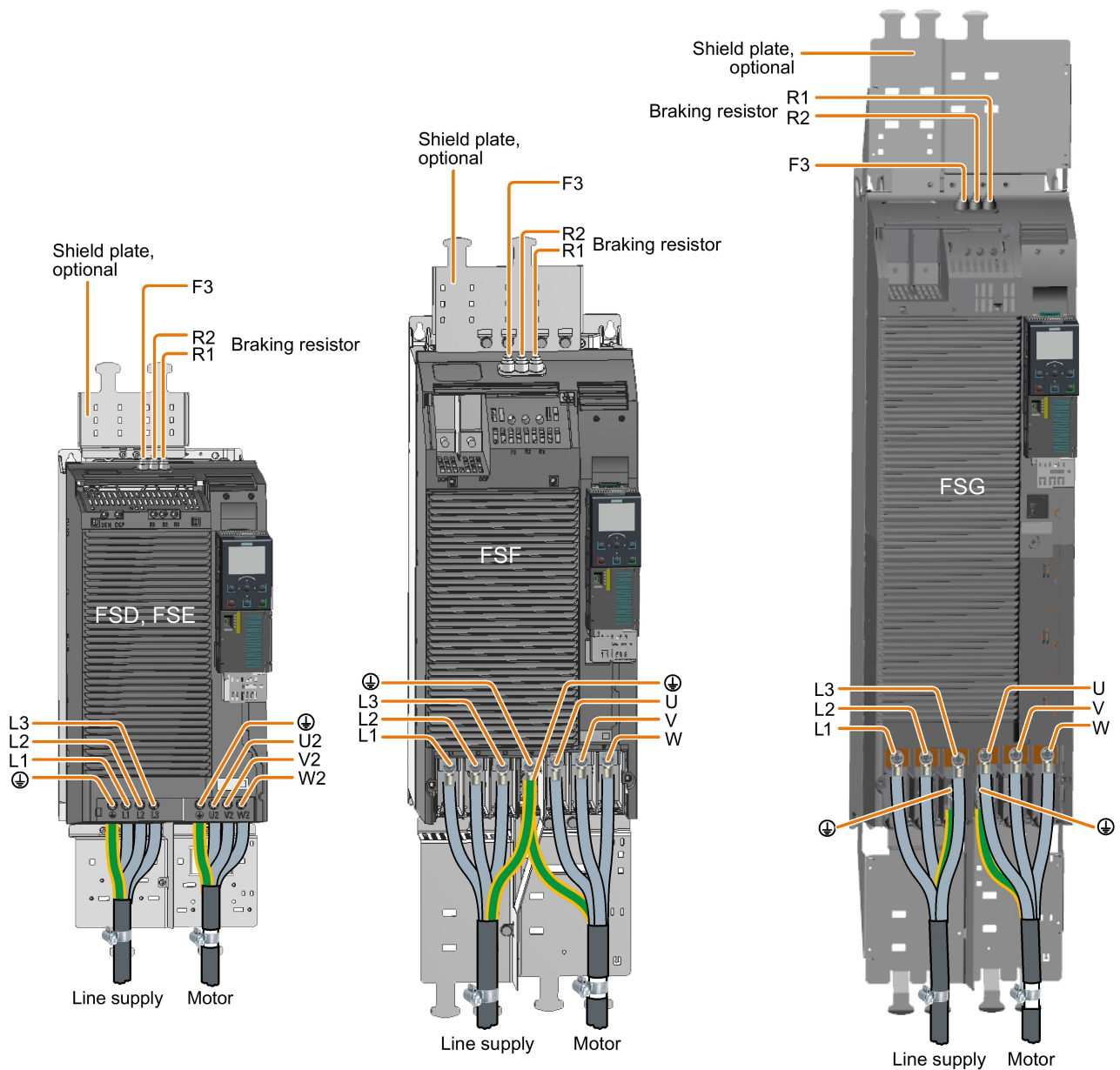

Figure 4-9 Connections for the line supply, motor and braking resistor

You must re-attach the connection covers in order to re-establish the touch protection of the inverter after it has been connected up.

Additional information when connecting FSG inverters

Note

Conductor cross-section 240 mm²

Cable lugs for M10 bolts according to SN71322 are suitable for cables with cross-sections of 35 mm² ... 185 mm² (1 AWG ... 2 × 350 MCM).

If you wish to establish connections with cables of 240 mm² (500 MCM), you must use narrow cable lugs, e.g. Klauke 12SG10. Other cable lugs are not suitable due to the narrow design of the inverter.

The maximum permissible width of the cable lugs is 37 mm (1.45 inches).

Remove the plastic insulating plate as shown below to gain better access to the terminals for the power connections.

⚠ WARNING

Damage to inverter as a result of operation without insulating plates

Without the insulating plates, voltage flashovers may occur between the phases.

- Replace the insulating plates after connecting the cables.

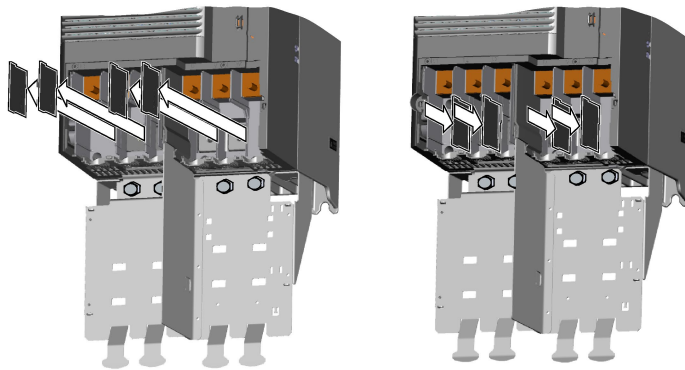

Braking resistor connection

Use the rubber cable gland as shown in the right-hand figure for connecting the braking resistor.

Using a sharp knife, cut the cap of the cable gland corresponding to the diameter of the connection cable of the braking resistor and establish the connections.

Connect the braking resistor at the R1 and R2 terminals.

An optional shield plate is available as strain relief for the connection cable of the braking resistor.



Top shield plate - FSD ... FSG (Page 128)

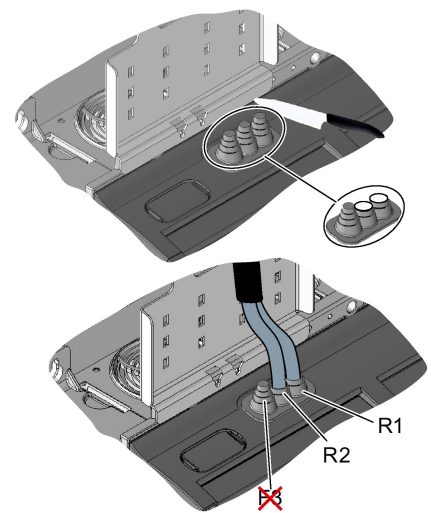

4.3 STO via Power Module terminals

Description

The "Safe Torque Off" (STO) safety function can be implemented via terminals on the power modules of frame sizes FSD ... FSG.

The "STO via power module terminals" safety function fulfills the following requirements:

- Safety integrity level 3 (SIL 3) to IEC 61508: 2010
- Category 3 and Performance Level (PL) e according to ISO 13849-1: 2008

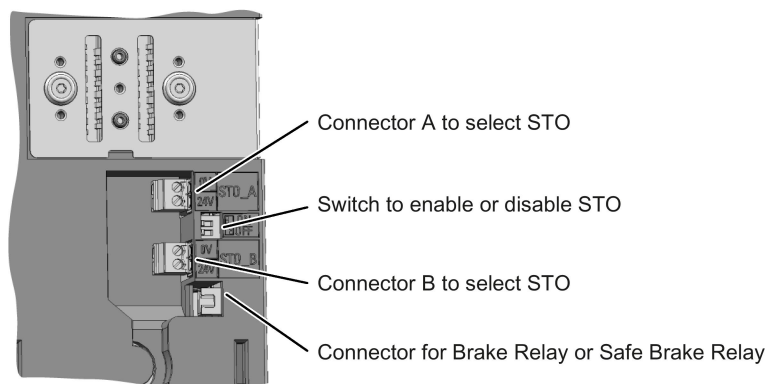

Figure 4-10 Terminals and switches for the "STO via power module terminals" function

The two switches have the following function:

- Both switches = ON: STO is enabled
- Both switches = OFF: STO is locked
- Two switches different: STO is disabled, the inverter signals a fault.

Terminals STO_A and STO_B are low active.

Connect line to select STO

Use a SELV or PELV power supply with 24 V DC (20.4 V ... 28.8 V, maximum 60 V briefly) for the STO_A and STO_B connections.

Use a shielded cable with the following properties:

- Length ≤ 30 m
- Cross section 0.5 mm² ... + 1.5 mm² (20 ... 16 AWG)
- Insulated for 600 V

Use conductor end sleeves, stripped length 7 mm.

Procedure1.
2.

1. Connect the cable to select STO at terminals STO_A and STO_B on the front of the power module.
2. Tighten the screws of the terminals with a torque of 0.2 Nm (2 lbf in).
3. Attach the shield to the shield plate of the Control Unit through the largest possible surface area.



You have connected the STO terminals.

Note**Configuring a safety function**

In order to use the "STO via power module terminals" safety function, the function has to be configured with a commissioning tool.

Further information and wiring examples are to be found in the "Safety Integrated" Function Manual.



Manuals for your inverter (Page 157)

4.4 Connecting the motor to the inverter in a star or delta connection

Standard induction motors with a rated power of approximately ≤ 3 kW are normally connected in a star/delta connection (Y/ Δ) at 400 V/230 V. For a 400-V line supply, you can connect the motor to the inverter either in a star or in a delta connection.

Operating the motor in a star connection

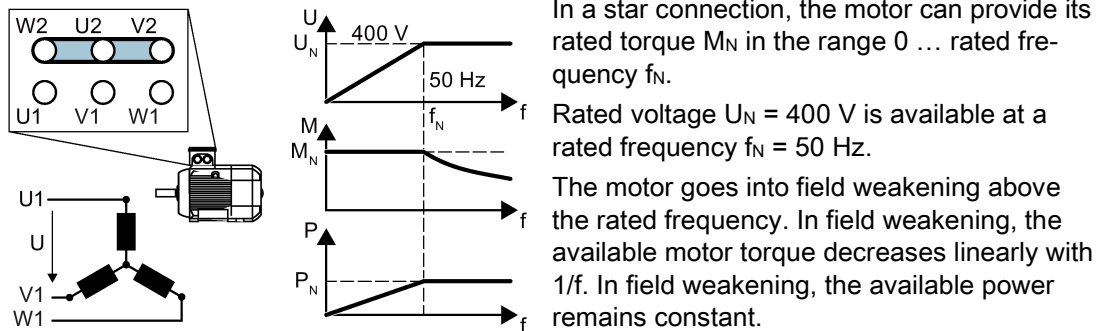

Operating the motor in a delta connection with 87 Hz characteristic

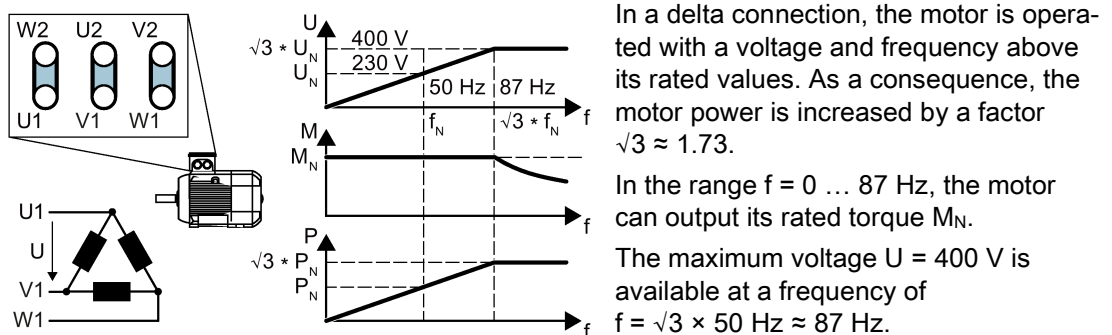

The motor only goes into field weakening above 87 Hz.

The higher motor power when operated with an 87 Hz characteristic has the following disadvantages:

- The inverter must supply approximately 1.73x current. Select an inverter based on its rated current - and not its rated power.
- The motor temperature increases more significantly than when operated with $f \leq 50$ Hz.
- The motor must have windings that are approved for a voltage $>$ rated voltage U_N .
- As the fan impeller rotates faster, the motor has a higher noise level than operation with $f \leq 50$ Hz.

Service and maintenance

WARNING

Fire or electric shock due to defective components

If an overcurrent protection device is triggered, the inverter may be defective. A defective inverter can cause a fire or electric shock.

- Have the inverter and the overcurrent protection device checked by a specialist.

Repair

WARNING

Fire or electric shock due to improper repair

Improper repair of the inverter may cause malfunctions or result in consequential damage such as fire or electric shock.

- Only commission the following persons to repair the inverter:
 - Siemens customer service
 - A repair center that has been authorized by Siemens
 - Specialist personnel who are thoroughly acquainted with all the warnings and operating procedures contained in this manual.
- Only use original spare parts when carrying out repairs.

Device disposal



This product is an electrical or electronic device that cannot be disposed of with household waste. Dispose of the device in accordance with the regulations valid in your country.

5.1 Maintenance

The purpose of maintenance is to maintain the specified condition of the Power Module.

Regularly remove dirt and pollution, and replace the fan in plenty of time.  Replacing a fan (Page 74)

Cleaning

Inverters with IP20 degree of protection - built-in units

Clean the inverter with an anti-static brush, a vacuum cleaner and areas that are difficult to access, using dry compressed air (max. 1 bar).

Inverters with push-through technology – PT devices

Clean the heatsink at regular intervals. If necessary, remove the air deflection plate at the rear. Use a torque of 2 Nm when reconnecting. The fans must be installed if you clean the heatsink using water.

Ventilation

The devices must be installed in a cabinet. Ensure that the cabinet's ventilation slots are not blocked. Check that the fan is functioning correctly.

Cables and screw terminals

Regularly check the cables for damage, and immediately replace any defective parts.

Regularly check that the screw terminals have been correctly tightened. Retighten the screws if necessary.

Note

The actual maintenance intervals depend on the installation and operating conditions.

Siemens offers its customers support in the form of service contracts. For further information, contact your Siemens regional office or sales office.

5.2 Commissioning after a long storage time

If the inverter was not operational for a longer period of time, it is possible that you must form the DC-link capacitors before switching on.

Form the DC-link capacitors in the following cases:

- If the inverter was not operational for longer than one year.
- If the date of manufacture of the inverter was more than one year ago when commissioning the drive system for the first time. The date of manufacture is coded in the serial number (see the next paragraph).

You form the DC-link capacitors by connecting power to the inverters as shown below.

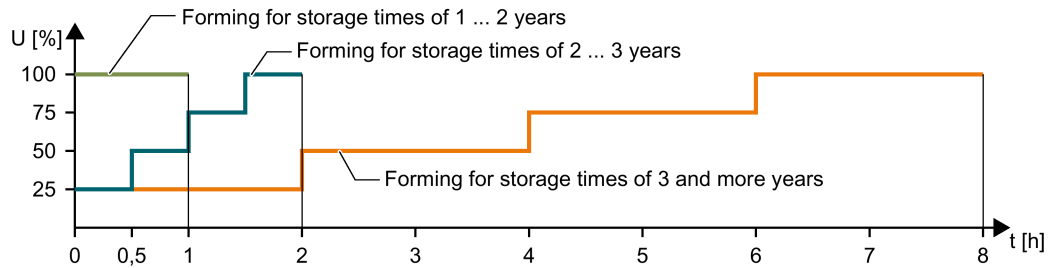

Figure 5-1 Forming the DC-link capacitors

Data of manufacture of the inverter

The date of manufacture of the inverter is coded in positions 3 - 6 of the serial number.

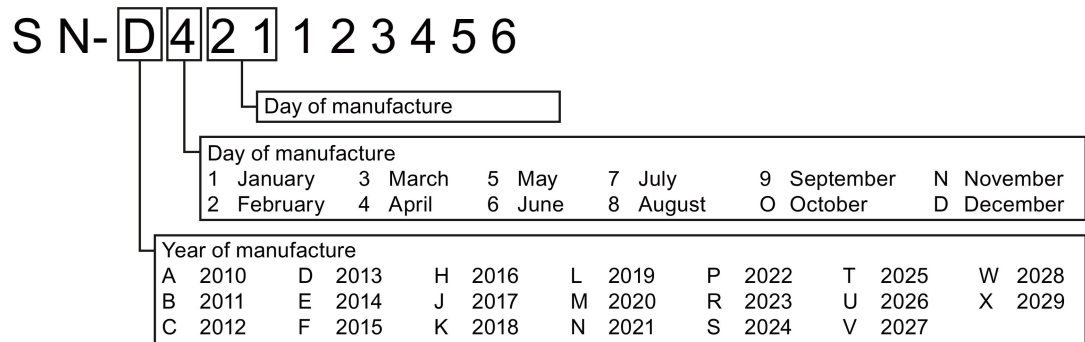

Figure 5-2 Data of manufacture in the serial number (example, April 21, 2013)

5.3 Replacing a fan

Service life of the fan

The average service life of the fan is 40,000 hours. In practice, however, the service life may deviate from this value. Especially a dusty environment can block up the fan.

The fan must be replaced in good time to ensure that the inverter is ready for operation.

Applies to all frame sizes

Proceed as follows to remove the fan unit:

Switch off the inverter power supply before replacing the fan.



! WARNING

Electric shock as a result of a residual charge in power components

After the power supply has been switched off, it takes up to 5 min. until the capacitors in the inverter have discharged so that the residual charge is at a non-hazardous level.

- Check the voltage at the inverter connections before you carry out any installation work.

5.3.1 Fan replacement FSA ... FSC

The fan module is installed at the bottom. It has one fan each for frame sizes FSA and FSB, and two for frame size C.

Procedure

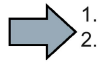

1. Withdraw the line and motor cable plug connectors and, if available, remove the braking resistor from the Power Module.
2. Remove the shield plate from the Power Module.
3. Remove the fan module from the Power Module in steps ① and ② as shown in the diagram. Use a screwdriver if necessary.

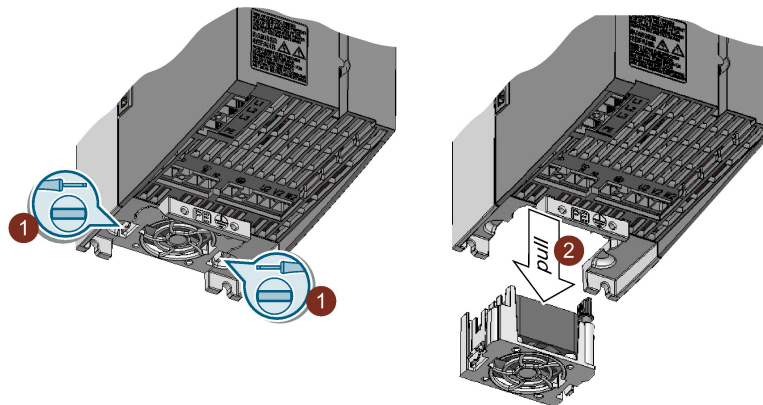

4. Install the new fan module in the inverse sequence.



You have replaced the fan module.

5.3.2 Fan replacement FSD ... FSF

The fan module is installed at the top.

Procedure

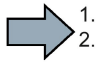

1. Remove the fan module from the Power Module in steps ① and ② as shown in the diagram. Use a screwdriver if necessary.

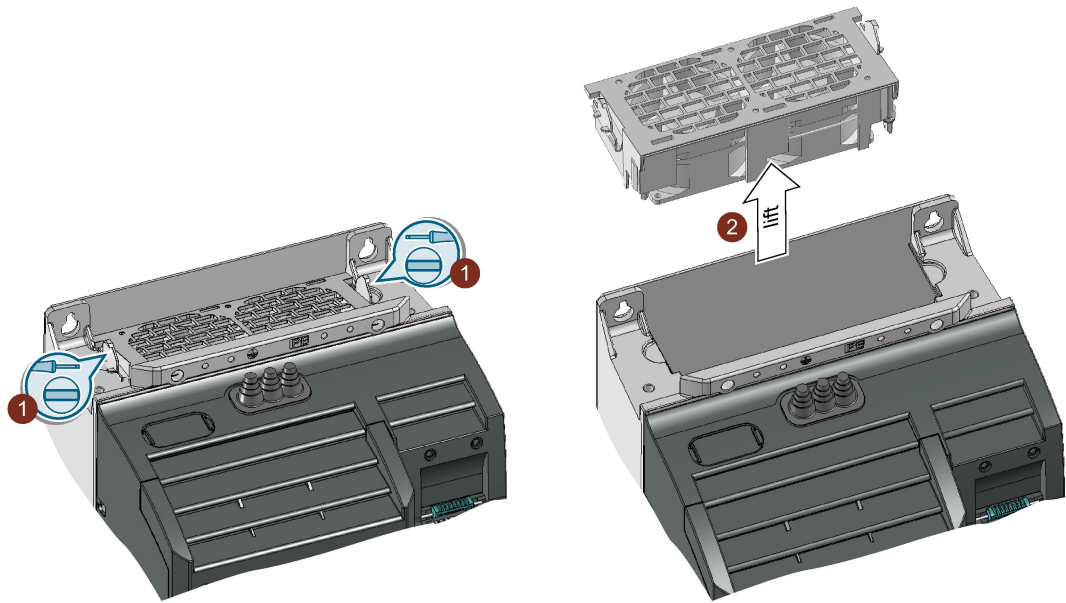

2. Additionally for PT devices:
Remove the interior fan as shown below.

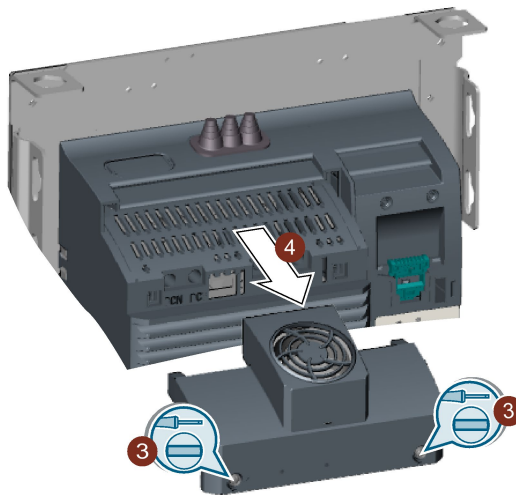

3. Install the new fan module in inverse sequence.
By inserting the fan module, you establish the electrical connection between the inverter and fan module.

■ You have replaced the fan module.

5.3.3 FSG fan replacement

The fan module is installed at the top.

Procedure

- ➔ 1. 1. Remove the fan module from the Power Module in steps ① and ② as shown in the diagram. Use a screwdriver.

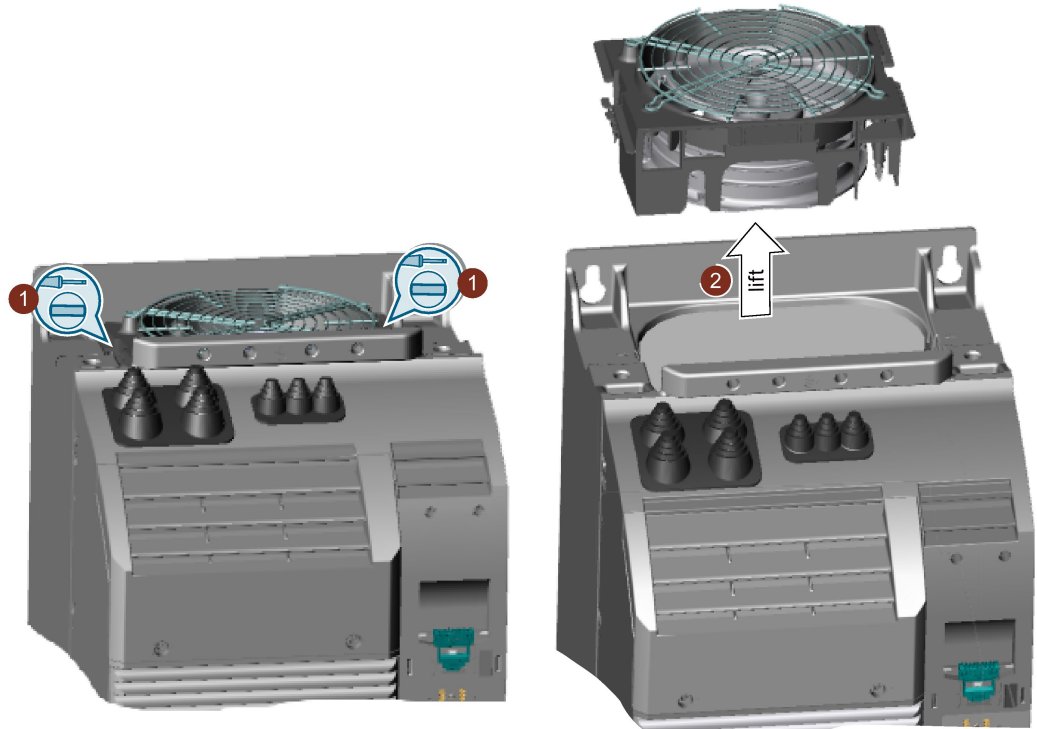

2. Install the new fan module in inverse sequence.
By inserting the fan module, you establish the electrical connection between the inverter and fan module.

■ You have replaced the fan module.

Technical data

Power loss of the Power Modules

Note

Power loss for the FSA ... FSC Power Modules

The values specified for the power loss are typical values at 100% of the rated speed and 100% of the load corresponding to Low Overload.

Power loss for the FSD ... FSG Power Modules

The values specified for the power loss are typical values at 90% of the rated speed and 100% of the load corresponding to Low Overload.

Protective organs for the Power Module

The fuses listed in the following tables are examples of suitable fuses.

Additional components for branch protection are available in the Internet:

 Branch protection and short-circuit strength according to UL and IEC (<https://support.industry.siemens.com/cs/ww/en/view/109486009>)

Number of starting operations for inverter

The frequency of operation for the inverter is every 120 s.

The number of starting operations states how often line voltage may be switched to the de-energized inverter.

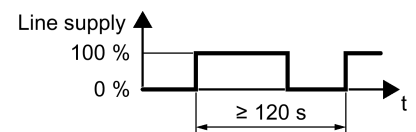

6.1 Electromagnetic compatibility - Overview

Electromagnetic compatibility according to EN61800-3



| Property | Version |
|--|---|
| Interference immunity | The inverters are suitable for use in the first and second industrial environments |
| Interference emission - second environment | Category C2 for inverters with integrated radio interference suppression filter |
| | Category C2 for inverters without filter with optional external radio interference suppression filter for grounded line supplies (recommended for operation in conjunction with a residual current protective device RCD) |
| | Category C3 for 690-V inverters with integrated radio interference suppression filter, frame size FSF, FSG |
| | Category C4 for inverters without integrated radio interference suppression filter for operation on IT line supplies |

Additional information as well as conditions for using the inverter in the first environment are provided in the following Section:



Electromagnetic compatibility of variable-speed drives (Page 119).

6.2 Ambient conditions

| Property | Version |
|--|--|
| Ambient conditions for transport in the transport packaging | |
| Climatic ambient conditions | - 40 °C ... + 70 °C, according to Class 2K4 to EN 60721-3-2 maximum humidity 95% at 40 °C |
| Mechanical ambient conditions | Shock and vibration permissible according to 1M2 to EN 60721-3-2 |
| Protection against chemical substances | Protected according to Class 2C2 to EN 60721-3-2 |
| Biological ambient conditions | Suitable according to Class 2B1 to EN 60721-3-2 |
| Ambient conditions for long-term storage in the product packaging | |
| Climatic ambient conditions | - 25 °C ... + 55 °C, according to Class 1K3 to EN 60721-3-1 |
| Protection against chemical substances | Protected according to Class 1C2 to EN 60721-3-1 |
| Biological ambient conditions | Suitable according to class 1B1 to EN 60721-3-1 |
| Ambient conditions in operation | |
| Installation altitude | Up to 1000 m above sea level without limitations  Restrictions for special ambient conditions (Page 116) |
| Climatic ambient conditions ¹⁾ | <ul style="list-style-type: none"> • FSA ... FSC ambient operating temperature ²⁾ <ul style="list-style-type: none"> – For operation according to Low Overload: -10 °C ... +40 °C – For operation according to High Overload: -10 °C ... +50 °C –  Restrictions for special ambient conditions (Page 116) • FSD ... FSG ambient operating temperature ²⁾ <ul style="list-style-type: none"> – For operation according to Low Overload: -20 °C ... +40 °C – For operation according to High Overload: -20 °C ... +50 °C –  Restrictions for special ambient conditions (Page 116) • Relative humidity: 5 ... 95%, condensation not permitted • Oil mist, salt mist, ice formation, condensation, dripping water, spraying water, splashing water and water jets are not permitted |
| Mechanical ambient conditions | Vibration test during operation according to IEC 60068-2-6 Test Fc (sinusoidal) <ul style="list-style-type: none"> • 0 ... 57 Hz: 0.075 mm deflection amplitude • 57 ... 150 Hz: 1 g acceleration amplitude • 10 frequency cycles per axis Shock test according to IEC 60068-2-27 Test Ea (half-sine) <ul style="list-style-type: none"> • 5 g peak acceleration • 30 ms duration • 3 shocks in all three axes in both directions |
| Protection against chemical substances | <ul style="list-style-type: none"> • FSA ... FSC: Protected according to 3C2 to EN 60721-3-3 • FSD ... FSG: 3C3 protection according to EN 60721-3-3 |

Technical data

6.2 Ambient conditions

| Property | Version |
|-------------------------------|--|
| Biological ambient conditions | Suitable according to 3B1 to EN 60721-3-3 |
| Pollution | Suitable for environments with degree of pollution 2 according to EN 61800-5-1 |
| Cooling | Forced air cooling AF, according to EN 60146 |
| Cooling air | Clean and dry air |
| Noise emission | Maximum 75 db(A) |

- 1) Increased ruggedness regarding temperature range and relative humidity; therefore better than 3K3 according to EN 60721-3-3
- 2) Observe the permissible ambient operating temperatures for the Control Unit and the Operator Panel (IOP-2 or BOP-2).

6.3 Overload capability of the inverter

Overload capability is the property of the inverter to temporarily supply a current that is higher than the rated current to accelerate a load. Two typical load cycles are defined to clearly demonstrate the overload capability: "Low Overload" and "High Overload"

Definitions

Base load

Constant load between the accelerating phases of the drive

Low Overload

- **LO base load input current**
Permissible input current for a "Low Overload" load cycle
- **LO base load output current**
Permissible output current for a "Low Overload" load cycle
- **LO base load power**
Rated power based on the LO base load output current

High Overload

- **HO base load input current**
Permissible input current for a "High Overload" load cycle
- **HO base load output current**
Permissible output current for a "High Overload" load cycle
- **HO base load power**
Rated power based on the HO base load output current

If not specified otherwise, the power and current data in the technical data always refer to a load cycle according to Low Overload.

We recommend the "SIZER" engineering software to select the inverter.

You can find additional information about SIZER on the Internet:



Download SIZER

<http://support.automation.siemens.com/WW/view/en/10804987/130000>

Load cycles and typical applications:

"Low Overload" load cycle

The "Low Overload" load cycle assumes a uniform base load with low requirements placed on brief accelerating phases. Typical applications when designing according to "Low Overload" include:

- Pumps, fans and compressors
- Wet or dry blasting technology
- Mills, mixers, kneaders, crushers, agitators
- Basic spindles
- Rotary kilns
- Extruders

"High Overload" load cycle

The "High Overload" load cycle permits, for reduced base load, dynamic accelerating phases. Typical applications when designing according to "High Overload" include:

- Horizontal and vertical conveyor technology (conveyor belts, roller conveyors, chain conveyors)
- Centrifuges
- Escalators/moving stairways
- Lifters/Lowerers
- Elevators
- Gantry cranes
- Cable railways
- Storage and retrieval machines

Typical inverter load cycles

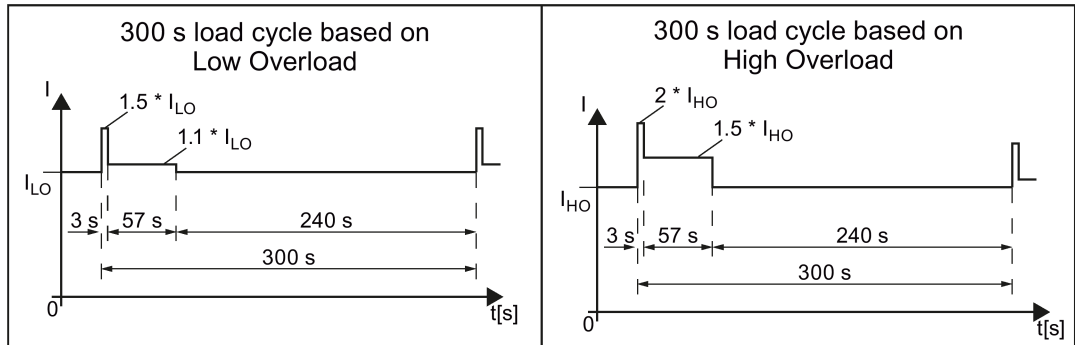





Figure 6-1 "Low Overload" and "High Overload" load cycles

6.4 Cable cross-sections and tightening torques

Table 6- 1 Connection, cross-section and tightening torque for PM240-2 Power Modules

| Inverters | Connection | | Cross-section, tightening torque | | Stripped insulation length |
|------------|---|---|--|--|----------------------------|
| | | | Metric | Imperial | |
| FSA | Line system, motor and braking resistor |  Plug connector with screw terminals | 1.5 ... 2.5 mm ² , 0.5 Nm | 16 ... 14 AWG, 4.5 lbf in | 8 mm |
| FSB | | | 1.5 ... 6 mm ² , 0.6 Nm | 16 ... 10 AWG, 5.5 lbf in | 8 mm |
| FSC | | | 6 ... 16 mm ² , 1.3 Nm | 10 ... 6 AWG, 12 lbf in | 10 mm |
| FSD | Line and motor | Screw-type terminal | 10 ... 35 mm ² , 2.5 ... 4.5 Nm | 20 ... 10 AWG, 22 lbf in 8 ... 2 AWG, 40 lbf in | 18 mm |
| | Braking resistor | | 2.5 ... 16 mm ² , 1.2 ... 1.5 Nm | 20 ... 6 AWG, 15 lbf in | 10 mm |
| FSE | Line and motor | Screw-type terminal | 25 ... 70 mm ² , 8 ... 10 Nm | 6 ... 3/0 AWG, 88.5 lbf in | 25 mm |
| | Braking resistor | | 10 ... 35 mm ² , 2.5 ... 4.5 Nm | 20 ... 10 AWG, 22 lbf in 8 ... 2 AWG, 40 lbf in | 18 mm |
| FSF | Line and motor |  Cable lug according to SN71322 for M10 bolts | 35 ... 2 × 120 mm ² , 22 ... 25 Nm | 1 AWG ... 2 × 4/0 AWG, 210 lbf.in | -- |
| | Braking resistor | Screw-type terminal | 25 ... 70 mm ² , 8 ... 10 Nm | 6 ... 3/0 AWG, 88.5 lbf in | 25 mm |
| FSG | Line and motor |  Cable lug according to SN71322 for M10 bolts | 35 ... 2 × 185 mm ² , 22 ... 25 Nm | 1 AWG ... 2 × 350 MCM, 210 lbf.in | -- |
| | Braking resistor | Screw-type terminal | 25 ... 70 mm ² , 8 ... 10 Nm | 6 ... 3/0 AWG, 88.5 lbf in | 25 mm |

6.5 Technical data, 200 V inverters

Motors for 200 V Power Modules

For the 200 V Power Modules, induction motors are permissible in the range from 25% ... 150% of the inverter power without any restrictions.



Permissible motors

Note

Motors for inverter operation

Only use motors that are suitable for operation with inverters with a DC link.

6.5.1 General data, 200 V inverters

| Property | Version | |
|--|---|--|
| Line voltage | FSA ... FSC | 200 V ... 240 V 1 AC ± 10% 0.55 kW ... 4 kW - LO 0.37 kW ... 3 kW - HO |
| | | 200 V ... 240 V 3 AC ± 10% 0.55 kW ... 7.5 kW - LO 0.37 kW ... 5.5 kW - HO |
| | FSD ... FSF | 200 V ... 240 V 3 AC ± 10% (in operation -20% < 1 min) |
| Line supply configurations | Grounded TN/TT line supplies or non-grounded IT line supplies  Permissible line supplies (Page 50) | |
| Line impedance | FSA ... FSC | 2% ≤ Uk < 4%. For Uk < 2%, we recommend a line reactor, or a Power Module with the next higher power rating. |
| | FSD ... FSF | No restrictions |
| Power factor λ | FSA ... FSC | 0.7 without line reactor for Uk ≥ 2% 0.85 with line reactor for Uk < 2% |
| | FSD ... FSF | > 0.9 |
| Output voltage | 0 V 3 AC ... 0.95 × input voltage | |
| Input frequency | 50 Hz ... 60 Hz, ± 3 Hz | |
| Output frequency | 0 ... 550 Hz, depending on the control mode | |
| Inrush current | < LO base load input current | |
| Overvoltage category according to EN 61800-5-1 | III for line supplies | |
| Pulse frequency | 4 kHz (factory setting), Adjustable in steps of 2 kHz. | |
| |  Current reduction as a function of the pulse frequency (Page 96) If you increase the pulse frequency, the inverter reduces the maximum output current. | |
| Short-circuit current (SCCR) and branch protection | Maximum permissible line short-circuit current ≤ 100 kA rms Minimum required short-circuit current ≥ 5 kA rms The length of the connecting cable from the line to the inverter may not reduce the minimum short-circuit current | |
| |  Branch protection and short-circuit strength according to UL and IEC https://support.industry.siemens.com/cs/ww/en/view/109479152 | |
| Braking methods | DC braking, compound braking, dynamic braking with integrated braking chopper | |
| Degree of protection according to EN 60529 | IP20 | |
| | IP55 PT devices outside the control cabinet | |
| Protection class according to EN 61800-5-1 | The inverters are devices with protection class I | |
| Touch protection according to EN 50274 | DGUV regulation 3 when used for the intended purpose | |
| Cooling in compliance with EN 60146 | Forced air cooling AF | |

Dependent on the input voltage and output power

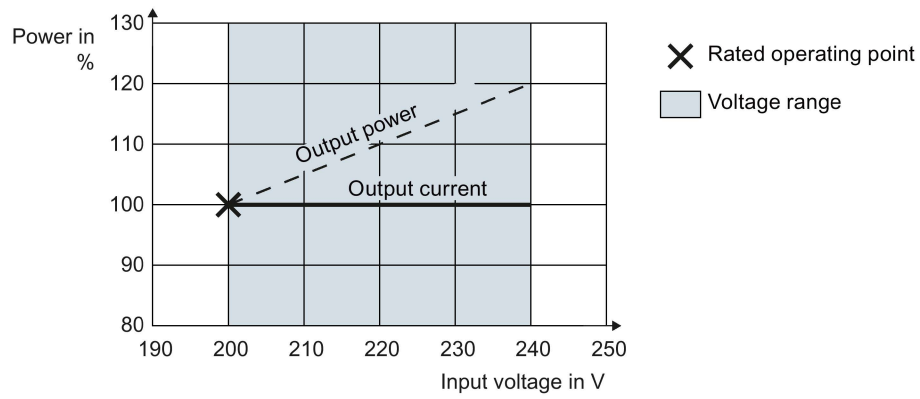

6.5.2 Specific technical data, 200 V inverters

Table 6- 2 PM240-2, IP20, frame size A, 200 V ... 240 V 1 AC / 3 AC

| Article No. without filter | 6SL3210-1PB13-0UL0 | 6SL3210-1PB13-8UL0 |
|---------------------------------|--------------------|--------------------|
| Article No. with filter | 6SL3210-1PB13-0AL0 | 6SL3210-1PB13-8AL0 |
| LO base load power | 0.55 kW | 0.75 kW |
| 1 AC LO base load input current | 7.5 A | 9.6 A |
| 3 AC LO base load input current | 4.2 A | 5.5 A |
| LO base load output current | 3.2 A | 4.2 A |
| HO base load power | 0.37 kW | 0.55 kW |
| 1 AC HO base load input current | 6.6 A | 8.4 A |
| 3 AC HO base load input current | 3.0 A | 4.2 A |
| HO base load output current | 2.3 A | 3.2 A |
| Fuse according to IEC | 3NA3805 (16 A) | 3NA3805 (16 A) |
| Fuse according to UL, class J | 15 A | 15 A |
| Power loss | 0.04 kW | 0.04 kW |
| Required cooling air flow | 5 l/s | 5 l/s |
| Weight without filter | 1.4 kg | 1.4 kg |
| Weight with filter | 1.6 kg | 1.6 kg |

Table 6- 3 PM240-2, PT, frame size A, 200 V ... 240 V 1 AC / 3 AC

| Article No. without filter | 6SL3211-1PB13-8UL0 |
|---------------------------------|--------------------|
| Article No. with filter | 6SL3211-1PB13-8AL0 |
| LO base load power | 0.75 kW |
| 1 AC LO base load input current | 9.6 A |
| 3 AC LO base load input current | 5.5 A |
| LO base load output current | 4.2 A |
| HO base load power | 0.55 kW |
| 1 AC HO base load input current | 8.4 A |
| 3 AC HO base load input current | 4.2 A |
| HO base load output current | 3.2 A |
| Fuse according to IEC | 3NA3 805 (16 A) |
| Fuse according to UL, class J | 15 A |
| Power loss | 0.04 kW |
| Required cooling air flow | 5 l/s |
| Weight without filter | 1.8 kg |
| Weight with filter | 2.0 kg |

Technical data

6.5 Technical data, 200 V inverters

Table 6- 4 PM240-2, IP20, frame size B, 200 V ... 240 V 1 AC / 3 AC

| Article No. without filter | 6SL3210-1PB15-5UL0 | 6SL3210-1PB17-4UL0 | 6SL3210-1PB21-0UL0 |
|---------------------------------|--------------------|--------------------|--------------------|
| Article No. with filter | 6SL3210-1PB15-5AL0 | 6SL3210-1PB17-4AL0 | 6SL3210-1PB21-0AL0 |
| LO base load power | 1.1 kW | 1.5 kW | 2.2 kW |
| 1 AC LO base load input current | 13.5 A | 18.1 A | 24.0 A |
| 3 AC LO base load input current | 7.8 A | 9.7 A | 13.6 A |
| LO base load output current | 6 A | 7.4 A | 10.4 A |
| HO base load power | 0.75 kW | 1.1 kW | 1.5 kW |
| 1 AC HO base load input current | 11.8 A | 15.8 A | 20.9 A |
| 3 AC HO base load input current | 5.5 A | 7.8 A | 9.7 A |
| HO base load output current | 4.2 A | 6 A | 7.4 A |
| Fuse according to IEC | 3NA3812 (32 A) | 3NA3812 (32 A) | 3NA3812 (32 A) |
| Fuse according to UL, class J | 35 A | 35 A | 35 A |
| Power loss | 0.05 kW | 0.07 kW | 0.12 kW |
| Required cooling air flow | 9.2 l/s | 9.2 l/s | 9.2 l/s |
| Weight without filter | 2.8 kg | 2.8 kg | 2.8 kg |
| Weight with filter | 3.1 kg | 3.1 kg | 3.1 kg |

Table 6- 5 PM240-2, PT, frame size B, 200 V ... 240 V 1 AC / 3 AC

| Article No. without filter | 6SL3211-1PB21-0UL0 |
|---------------------------------|-----------------------|
| Article No. with filter | 6SL3211-1PB21-0AL0 |
| LO base load power | 2.2 kW |
| 1 AC LO base load input current | 24.0 A |
| 3 AC LO base load input current | 13.6 A |
| LO base load output current | 10.4 A |
| HO base load power | 1.5 kW |
| 1 AC HO base load input current | 20.9 A |
| 3 AC HO base load input current | 9.7 A |
| HO base load output current | 7.4 A |
| Fuse according to IEC | 3NA3812 (32 A) |
| Fuse according to UL, class J | 35 A |
| Power loss | 0.12 kW ¹⁾ |
| Required cooling air flow | 9.2 l/s |
| Weight without filter | 3.4 kg |
| Weight with filter | 3.7 kg |

¹⁾ approx. 0.08 kW through the heat sink

Table 6- 6 PM240-2, IP 20, frame size C, 200 V ... 240 V 1 AC / 3 AC

| Article No. without filter | 6SL3210-1PB21-4UL0 | 6SL3210-1PB21-8UL0 |
|---------------------------------|--------------------|--------------------|
| Article No. with filter | 6SL3210-1PB21-4AL0 | 6SL3210-1PB21-8AL0 |
| LO base load power | 3 kW | 4 kW |
| 1 AC LO base load input current | 35.9 A | 43.0 A |
| 3 AC LO base load input current | 17.7 A | 22.8 A |
| LO base load output current | 13.6 A | 17.5 A |
| HO base load power | 2.2 kW | 3 kW |
| 1 AC HO base load input current | 31.3 A | 37.5 A |
| 3 AC HO base load input current | 13.6 A | 17.7 A |
| HO base load output current | 10.4 A | 13.6 A |
| Fuse according to IEC | 3NA3820 (50 A) | 3NA3820 (50 A) |
| Fuse according to UL, class J | 50 A | 50 A |
| Power loss | 0.14 kW | 0.18 kW |
| Required cooling air flow | 18.5 l/s | 18.5 l/s |
| Weight without filter | 5.0 kg | 5.0 kg |
| Weight with filter | 5.2 kg | 5.2 kg |

Table 6- 7 PM240-2, PT, frame size C, 200 V ... 240 V 1 AC / 3 AC

| Article No. without filter | 6SL3211-1PB21-8UL0 |
|---------------------------------|-----------------------|
| Article No. with filter | 6SL3211-1PB21-8AL0 |
| LO base load power | 4 kW |
| 1 AC LO base load input current | 43.0 A |
| 3 AC LO base load input current | 22.8 A |
| LO base load output current | 17.5 A |
| HO base load power | 3 kW |
| 1 AC HO base load input current | 37.5 A |
| 3 AC HO base load input current | 17.7 A |
| HO base load output current | 13.6 A |
| Fuse according to IEC | 3NA3820 (50 A) |
| Fuse according to UL, class J | 50 A |
| Power loss | 0.18 kW ¹⁾ |
| Required cooling air flow | 18.5 l/s |
| Weight without filter | 5.9 kg |
| Weight with filter | 6.2 kg |

¹⁾ approx. 0.09 kW through the heat sink

6.5 Technical data, 200 V inverters

Table 6- 8 PM240-2, IP 20, frame size C, 200 V ... 240 V 3 AC

| Article No. without filter | 6SL3210-1PC22-2UL0 | 6SL3210-1PC22-8UL0 |
|-------------------------------|--------------------|--------------------|
| Article No. with filter | 6SL3210-1PC22-2AL0 | 6SL3210-1PC22-8AL0 |
| LO base load power | 5.5 kW | 7.5 kW |
| LO base load input current | 28.6 A | 36.4 A |
| LO base load output current | 22.0 A | 28.0 A |
| HO base load power | 4 kW | 5.5 kW |
| HO base load input current | 22.8 A | 28.6 A |
| HO base load output current | 17.5 A | 22.0 A |
| Fuse according to IEC | 3NA3820 (50 A) | 3NA3820 (50 A) |
| Fuse according to UL, class J | 50 A | 50 A |
| Power loss | 0.2 kW | 0.26 kW |
| Required cooling air flow | 18.5 l/s | 18.5 l/s |
| Weight without filter | 5.0 kg | 5.0 kg |
| Weight with filter | 5.2 kg | 5.2 kg |

Table 6- 9 PM240-2, PT, frame size C, 200 V ... 240 V 3 AC

| Article No. without filter | 6SL3211-1PC22-2UL0 | 6SL3211-1PC22-8UL0 |
|-------------------------------|----------------------|-----------------------|
| Article No. with filter | 6SL3211-1PC22-2AL0 | 6SL3211-1PC22-8AL0 |
| LO base load power | 5.5 kW | 7.5 kW |
| LO base load input current | 28.6 A | 36.4 A |
| LO base load output current | 22.0 A | 28.0 A |
| HO base load power | 4 kW | 5.5 kW |
| HO base load input current | 22.8 A | 28.6 A |
| HO base load output current | 17.5 A | 22.0 A |
| Fuse according to IEC | 3NA3820 (50 A) | 3NA3820 (50 A) |
| Fuse according to UL, class J | 50 A | 50 A |
| Power loss | 0.2 kW ¹⁾ | 0.26 kW ²⁾ |
| Required cooling air flow | 18.5 l/s | 18.5 l/s |
| Weight without filter | 5.9 kg | 5.9 kg |
| Weight with filter | 6.2 kg | 6.2 kg |

¹⁾ approx. 0.2 kW through the heatsink

²⁾ approx. 0.25 kW through the heatsink

Table 6- 10 PM240-2, IP20, frame size D, 200 V ... 240 V 3 AC

| Article No. without filter | 6SL3210-1PC24-2UL0 | 6SL3210-1PC25-4UL0 | 6SL3210-1PC26-8UL0 |
|-------------------------------|--------------------|--------------------|--------------------|
| LO base load power | 11 kW | 15 kW | 18.5 kW |
| LO base load input current | 40 A | 51 A | 64 A |
| LO base load output current | 42 A | 54 A | 68 A |
| HO base load power | 7.5 kW | 11 kW | 15 kW |
| HO base load input current | 36 A | 43 A | 56 A |
| HO base load output current | 35 A | 42 A | 54 A |
| Fuse according to IEC | 3NA3822 (63 A) | 3NA3824 (80 A) | 3NA3830 (100 A) |
| Fuse according to UL, class J | 60 A | 70 A | 90 A |
| Power loss | 0.45 kW | 0.61 kW | 0.82 kW |
| Required cooling air flow | 55 l/s | 55 l/s | 55 l/s |
| Weight | 17 kg | 17 kg | 17 kg |

Table 6- 11 PM240-2, PT, frame size D, 200 V ... 240 V 3 AC

| Article No. without filter | 6SL3211-1PC26-8UL0 |
|-------------------------------|-----------------------|
| LO base load power | 18.5 kW |
| LO base load input current | 64 A |
| LO base load output current | 68 A |
| HO base load power | 15 kW |
| HO base load input current | 56 A |
| HO base load output current | 54 A |
| Fuse according to IEC | 3NA3830 (100 A) |
| Fuse according to UL, class J | 90 A |
| Power loss | 0.82 kW ¹⁾ |
| Required cooling air flow | 55 l/s |
| Weight | 19.5 kg |

¹⁾ approx. 0.72 kW through the heatsink

6.5 Technical data, 200 V inverters

Table 6- 12 PM240-2, IP20, frame size E, 200 V ... 240 V 3 AC

| Article No. without filter | 6SL3210-1PC28-0UL0 | 6SL3210-1PC31-1UL0 |
|-------------------------------|--------------------|--------------------|
| LO base load power | 22 kW | 30 kW |
| LO base load input current | 76 A | 98 A |
| LO base load output current | 80 A | 104 A |
| HO base load power | 18.5 kW | 22 kW |
| HO base load input current | 71 A | 83 A |
| HO base load output current | 68 A | 80 A |
| Fuse according to IEC | 3NA3830 (100 A) | 3NA3836 (160 A) |
| Fuse according to UL, class J | 100 A | 150 A |
| Power loss | 0.92 kW | 1.28 kW |
| Required cooling air flow | 83 l/s | 83 l/s |
| Weight | 26 kg | 26 kg |

Table 6- 13 PM240-2, PT, frame size E, 200 V to 240 V 3 AC

| Article No. without filter | 6SL3211-1PC31-1UL0 |
|-------------------------------|-----------------------|
| LO base load power | 30 kW |
| LO base load input current | 98 A |
| LO base load output current | 104 A |
| HO base load power | 22 kW |
| HO base load input current | 83 A |
| HO base load output current | 80 A |
| Fuse according to IEC | 3NA3836 (160 A) |
| Fuse according to UL, class J | 150 A |
| Power loss | 1.28 kW ¹⁾ |
| Required cooling air flow | 83 l/s |
| Weight | 29 kg |

¹⁾ approx. 1.1 kW through the heatsink

Table 6- 14 PM240-2, IP20, frame size F, 200 V ... 240 V 3 AC

| Article No. without filter | 6SL3210-1PC31-3UL0 | 6SL3210-1PC31-6UL0 | 6SL3210-1PC31-8UL0 |
|-------------------------------|--------------------|--------------------|--------------------|
| LO base load power | 37 kW | 45 kW | 55 kW |
| LO base load input current | 126 A | 149 A | 172 A |
| LO base load output current | 130 A | 154 A | 178 A |
| HO base load power | 30 kW | 37 kW | 45 kW |
| HO base load input current | 110 A | 138 A | 164 A |
| HO base load output current | 104 A | 130 A | 154 A |
| Fuse according to IEC | 3NA3140 (200 A) | 3NA3140 (200 A) | 3NA3142 (224 A) |
| Fuse according to UL, class J | 175 A | 200 A | 250 A |
| Power loss | 1.38 kW | 1.72 kW | 2.09 kW |
| Required cooling air flow | 153 l/s | 153 l/s | 153 l/s |
| Weight | 57 kg | 57 kg | 57 kg |

Table 6- 15 PM240-2, PT, frame size F, 200 V to 240 V 3 AC

| Article No. without filter | 6SL3211-1PC31-8UL0 |
|-------------------------------|-----------------------|
| LO base load power | 55 kW |
| LO base load input current | 172 A |
| LO base load output current | 178 A |
| HO base load power | 45 kW |
| HO base load input current | 164 A |
| HO base load output current | 154 A |
| Fuse according to IEC | 3NA3142 (224 A) |
| Fuse according to UL, class J | 250 A |
| Power loss | 2.09 kW ¹⁾ |
| Required cooling air flow | 153 l/s |
| Weight | 60 kg |

¹⁾ approx. 1.9 kW through the heatsink

6.5.3 Current derating depending on the pulse frequency, 200 V inverters

| Article number | LO power [kW] | Pulse frequency [kHz] | | | | | | | |
|------------------------|---------------|---------------------------------|-------------|-------|-------|------|-----|------|------|
| | | 2 | 4 *) | 6 | 8 | 10 | 12 | 14 | 16 |
| | | LO base load output current [A] | | | | | | | |
| 6SL3210-1PB13-0 . LO | 0.55 | 3.2 | 3.2 | 2.7 | 2.2 | 1.9 | 1.6 | 1.4 | 1.3 |
| 6SL321 . -1PB13-8 . LO | 0.75 | 4.2 | 4.2 | 3.6 | 2.9 | 2.5 | 2.1 | 1.9 | 1.7 |
| 6SL3210-1PB15-5 . LO | 1.1 | 6 | 6 | 5.1 | 4.2 | 3.6 | 3 | 2.7 | 2.4 |
| 6SL3210-1PB17-4 . LO | 1.5 | 7.4 | 7.4 | 6.3 | 5.2 | 4.4 | 3.7 | 3.3 | 3 |
| 6SL321 . -1PB21-0 . LO | 2.2 | 10.4 | 10.4 | 8.8 | 7.3 | 6.2 | 5.2 | 4.7 | 4.2 |
| 6SL3210-1PB21-4 . LO | 3 | 13.6 | 13.6 | 11.6 | 9.5 | 8.2 | 6.8 | 6.1 | 5.4 |
| 6SL321 . -1PB21-8 . LO | 4 | 17.5 | 17.5 | 14.9 | 12.3 | 10.5 | 8.8 | 7.9 | 7 |
| 6SL3210-1PC22-2 . LO | 5.5 | 22 | 22 | 18.7 | 15.4 | 13.2 | 11 | 9.9 | 8.8 |
| 6SL3210-1PC22-8 . LO | 7.5 | 28 | 28 | 23.8 | 19.6 | 16.8 | 14 | 12.6 | 11.2 |
| 6SL3210-1PC24-2UL0 | 11 | 42 | 42 | 35.7 | 29.4 | 25.2 | 21 | 18.9 | 16.8 |
| 6SL3210-1PC25-4UL0 | 15 | 54 | 54 | 45.9 | 37.8 | 32.4 | 27 | 24.3 | 21.6 |
| 6SL321 . -1PC26-8UL0 | 18.5 | 68 | 68 | 57.8 | 47.6 | 40.8 | 34 | 30.6 | 27.2 |
| 6SL3210-1PC28-0UL0 | 22 | 80 | 80 | 68 | 56 | 48 | 40 | 36 | 32 |
| 6SL321 . -1PC31-1UL0 | 30 | 104 | 104 | 88.4 | 72.8 | 62.4 | 52 | 46.8 | 41.6 |
| 6SL3210-1PC31-3UL0 | 37 | 130 | 130 | 110.5 | 91 | --- | --- | --- | --- |
| 6SL3210-1PC31-6UL0 | 45 | 154 | 154 | 130.9 | 107.8 | --- | --- | --- | --- |
| 6SL321 . -1PC31-8UL0 | 55 | 178 | 178 | 151.3 | 124.6 | --- | --- | --- | --- |

*) Factory setting

The permissible motor cable length depends on the particular cable type and the pulse frequency that has been selected

6.6 Technical data, 400 V inverters

Motors for 400 V Power Modules

For the 400 V Power Modules, induction motors are permissible in the range from 25 % ... 150 % of the inverter power without any restrictions.



Permissible motors

Note

Motors for inverter operation

Only use motors that are suitable for operation with inverters with a DC link.

6.6.1 General data, 400 V inverters

| Property | Version |
|--|--|
| Line voltage | FSA ... FSC 380 V ... 480 V 3 AC ± 10% |
| | FSD ... FSG 380 V ... 480 V 3 AC ± 10% (in operation -20% < 1 min) |
| Line supply configurations | Grounded TN/TT line supplies or non-grounded IT line supplies  Permissible line supplies (Page 50) |
| Line impedance | FSA ... FSC 1% ≤ Uk < 4%, for values smaller than 1%, we recommend a line reactor, or a Power Module with the next higher power rating. |
| | FSD ... FSG No restrictions |
| Power factor λ | FSA ... FSC 0.7 without line reactor for Uk ≥ 1% 0.85 with line reactor for Uk < 1% |
| | FSD ... FSG > 0.9 |
| Output voltage | 0 V 3 AC ... 0.95 x input voltage (max.) |
| Input frequency | 50 Hz ... 60 Hz, ± 3 Hz |
| Output frequency | 0 ... 550 Hz, depending on the control mode |
| Inrush current | < LO base load input current |
| Overvoltage category according to EN 61800-5-1 | III for line supplies |
| Pulse frequency | Factory setting |
| | <ul style="list-style-type: none"> • 4 kHz for devices with an LO base load power < 110 kW • 2 kHz for devices with an LO base load power ≥ 110 kW Can be adjusted in 2 kHz steps as follows: <ul style="list-style-type: none"> • 2 kHz ... 16 kHz for devices with an LO base load power < 55 kW • 2 kHz ... 8 kHz for devices with an LO base load output of 55 kW ... 90 kW and ≥ 160 kW • 2 kHz ... 4 kHz for devices with an LO base load power of 110 kW ... 132 kW  Current reduction as a function of the pulse frequency (Page 108) If you increase the pulse frequency, the inverter reduces the maximum output current. |
| Short-circuit current (SCCR) and branch protection | Maximum permissible line short-circuit current ≤ 100 kA rms Minimum required short-circuit current ≥ 18 kA rms |
| | The length of the connecting cable from the line to the inverter may not reduce the minimum short-circuit current  Branch protection and short-circuit strength according to UL and IEC https://support.industry.siemens.com/cs/ww/en/view/109479152 |
| Braking methods | DC braking, compound braking, dynamic braking with integrated braking chopper |
| Degree of protection according to EN 60529 | IP20 |
| | IP55 PT devices outside the control cabinet |
| Protection class according to EN 61800-5-1 | The inverters are devices with protection class I |
| Touch protection according to EN 50274 | DGUV regulation 3 when used for the intended purpose |
| Cooling in compliance with EN 60146 | Forced air cooling AF |

Dependent on the input voltage and output power

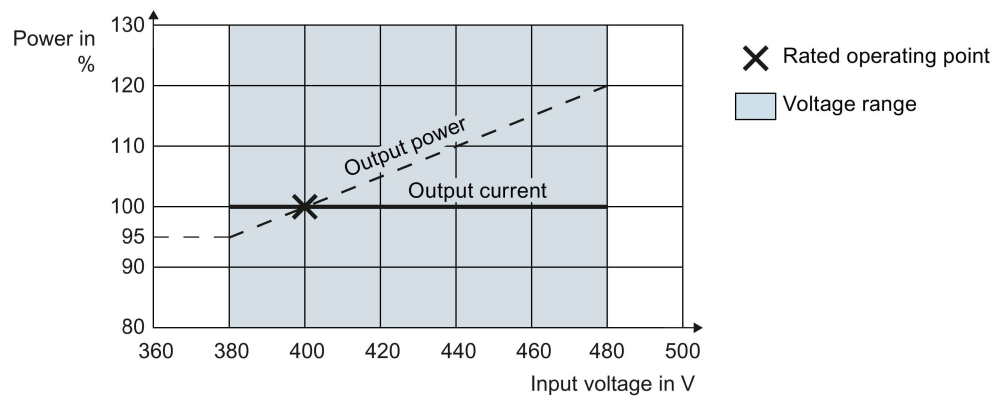

6.6.2 Specific technical data, 400 V inverters

Table 6- 16 PM240-2, IP20, frame size A, 380 V ... 480 V 3 AC

| Article No. without filter | 6SL3210-1PE11-8UL1 | 6SL3210-1PE12-3UL1 | 6SL3210-1PE13-2UL1 |
|-------------------------------|--------------------|--------------------|--------------------|
| Article No. with filter | 6SL3210-1PE11-8AL1 | 6SL3210-1PE12-3AL1 | 6SL3210-1PE13-2AL1 |
| LO base load power | 0.55 kW | 0.75 kW | 1.1 kW |
| LO base load input current | 2.3 A | 2.9 A | 4.1 A |
| LO base load output current | 1.7 A | 2.2 A | 3.1 A |
| HO base load power | 0.37 kW | 0.55 kW | 0.75 kW |
| HO base load input current | 2.0 A | 2.6 A | 3.3 A |
| HO base load output current | 1.3 A | 1.7 A | 2.2 A |
| Fuse according to IEC | 3NA3805 (16 A) | 3NA3805 (16 A) | 3NA3805 (16 A) |
| Fuse according to UL, class J | 10 A | 10 A | 15 A |
| Power loss | 0.04 kW | 0.04 kW | 0.04 kW |
| Required cooling air flow | 5 l/s | 5 l/s | 5 l/s |
| Weight without filter | 1.3 kg | 1.3 kg | 1.3 kg |
| Weight with filter | 1.5 kg | 1.5 kg | 1.5 kg |

Table 6- 17 PM240-2, IP20, frame size A, 380 V ... 480 V 3 AC

| Article No. without filter | 6SL3210-1PE14-3UL1 | 6SL3210-1PE16-1UL1 | 6SL3210-1PE18-0UL1 |
|-------------------------------|--------------------|--------------------|--------------------|
| Article No. with filter | 6SL3210-1PE14-3AL1 | 6SL3210-1PE16-1AL1 | 6SL3210-1PE18-0AL1 |
| LO base load power | 1.5 kW | 2.2 kW | 3.0 kW |
| LO base load input current | 5.5 A | 7.7 A | 10.1 A |
| LO base load output current | 4.1 A | 5.9 A | 7.7 A |
| HO base load power | 1.1 kW | 1.5 kW | 2.2 kW |
| HO base load input current | 4.7 A | 6.1 A | 8.8 A |
| HO base load output current | 3.1 A | 4.1 A | 5.9 A |
| Fuse according to IEC | 3NA3805 (16 A) | 3NA3805 (16 A) | 3NA3805 (16 A) |
| Fuse according to UL, class J | 20 A | 30 A | 30 A |
| Power loss | 0.07 kW | 0.1 kW | 0.12 kW |
| Required cooling air flow | 5 l/s | 5 l/s | 5 l/s |
| Weight without filter | 1.4 kg | 1.4 kg | 1.4 kg |
| Weight with filter | 1.6 kg | 1.6 kg | 1.6 kg |

Table 6- 18 PM240-2, PT, frame size A, 380 V ... 480 V 3 AC

| Article No. without filter | 6SL3211-1PE18-0UL1 |
|-------------------------------|-----------------------|
| Article No. with filter | 6SL3211-1PE18-0AL1 |
| LO base load power | 3.0 kW |
| LO base load input current | 10.1 A |
| LO base load output current | 7.7 A |
| HO base load power | 2.2 kW |
| HO base load input current | 8.8 A |
| HO base load output current | 5.9 A |
| Fuse according to IEC | 3NA3805 (16 A) |
| Fuse according to UL, class J | 30 A |
| Power loss without filter | 0.12 kW ¹⁾ |
| Required cooling air flow | 7 l/s |
| Weight without filter | 1.8 kg |
| Weight with filter | 2.0 kg |

1) approx. 0.1 kW through the heatsink

Table 6- 19 PM240-2, IP20, frame size B, 380 V ... 480 V 3 AC

| Article No. without filter | 6SL3210-1PE21-1UL0 | 6SL3210-1PE21-4UL0 | 6SL3210-1PE21-8UL0 |
|-------------------------------|--------------------|--------------------|--------------------|
| Article No. with filter | 6SL3210-1PE21-1AL0 | 6SL3210-1PE21-4AL0 | 6SL3210-1PE21-8AL0 |
| LO base load power | 4.0 kW | 5.5 kW | 7.5 kW |
| LO base load input current | 13.3 A | 17.2 A | 22.2 A |
| LO base load output current | 10.2 A | 13.2 A | 18.0 A |
| HO base load power | 3.0 kW | 4.0 kW | 5.5 kW |
| HO base load input current | 11.6 A | 15.3 A | 19.8 A |
| HO base load output current | 7.7 A | 10.2 A | 13.2 A |
| Fuse according to IEC | 3NA3812 (32 A) | 3NA3812 (32 A) | 3NA3812 (32 A) |
| Fuse according to UL, class J | 35 A | 35 A | 35 A |
| Power loss | 0.11 kW | 0.15 kW | 0.2 kW |
| Required cooling air flow | 9.2 l/s | 9.2 l/s | 9.2 l/s |
| Weight without filter | 2.9 kg | 2.9 kg | 3.0 kg |
| Weight with filter | 3.1 kg | 3.1 kg | 3.2 kg |

Technical data

6.6 Technical data, 400 V inverters

Table 6- 20 PM240-2, PT, frame size B, 380 V ... 480 V 3 AC

| | |
|-----------------------------------|---------------------------|
| Article No. without filter | 6SL3211-1PE21-8UL0 |
| Article No. with filter | 6SL3211-1PE21-8AL0 |
| LO base load power | 7.5 kW |
| LO base load input current | 22.2 A |
| LO base load output current | 18.0 A |
| HO base load power | 5.5 kW |
| HO base load input current | 19.8 A |
| HO base load output current | 13.7 A |
| Fuse according to IEC | 3NA3812 (32 A) |
| Fuse according to UL, class J | 35 A |
| Power loss | 0.2 kW ¹⁾ |
| Required cooling air flow | 9.2 l/s |
| Weight without filter | 3.6 kg |
| Weight with filter | 3.9 kg |

1) approx. 0.16 kW through the heatsink

Table 6- 21 PM240-2, IP20, frame size C, 380 V ... 480 V 3 AC

| | | |
|-----------------------------------|---------------------------|---------------------------|
| Article No. without filter | 6SL3210-1PE22-7UL0 | 6SL3210-1PE23-3UL0 |
| Article No. with filter | 6SL3210-1PE22-7AL0 | 6SL3210-1PE23-3AL0 |
| LO base load power | 11.0 kW | 15.0 kW |
| LO base load input current | 32.6 A | 39.9 A |
| LO base load output current | 26.0 A | 32.0 A |
| HO base load power | 7.5 kW | 11.0 kW |
| HO base load input current | 27.0 A | 36.0 A |
| HO base load output current | 18.0 A | 26.0 A |
| Fuse according to IEC | 3NA3820 (50 A) | 3NA3820 (50 A) |
| Fuse according to UL, class J | 50 A | 50 A |
| Power loss | 0.3 kW | 0.37 kW |
| Required cooling air flow | 18.5 l/s | 18.5 l/s |
| Weight without filter | 4.7 kg | 4.8 kg |
| Weight with filter | 5.3 kg | 5.4 kg |

Table 6- 22 PM240-2, PT, frame size C, 380 V ... 480 V 3 AC

| Article No. without filter | 6SL3211-1PE23-3UL0 |
|-------------------------------|-----------------------|
| Article No. with filter | 6SL3211-1PE23-3AL0 |
| LO base load power | 15.0 kW |
| LO base load input current | 39.9 A |
| LO base load output current | 32.0 A |
| HO base load power | 11.0 kW |
| HO base load input current | 36.0 A |
| HO base load output current | 26.0 A |
| Fuse according to IEC | 3NA3820 (50 A) |
| Fuse according to UL, class J | 50 A |
| Power loss | 0.37 kW ¹⁾ |
| Required cooling air flow | 18.5 l/s |
| Weight without filter | 5.8 kg |
| Weight with filter | 6.3 kg |

1) approx. 0.3 kW through the heatsink

Table 6- 23 PM240-2, IP20, frame size D, 380 V ... 480 V 3 AC

| Article No. without filter | 6SL3210-1PE23-8UL0 | 6SL3210-1PE24-5UL0 | 6SL3210-1PE26-0UL0 |
|-------------------------------|--------------------|--------------------|--------------------|
| Article No. with filter | 6SL3210-1PE23-8AL0 | 6SL3210-1PE24-5AL0 | 6SL3210-1PE26-0AL0 |
| LO base load power | 18.5 kW | 22 kW | 30 kW |
| LO base load input current | 36 A | 42 A | 57 A |
| LO base load output current | 38 A | 45 A | 60 A |
| HO base load power | 15 kW | 18.5 kW | 22 kW |
| HO base load input current | 33 A | 38 A | 47 A |
| HO base load output current | 32 A | 38 A | 45 A |
| Fuse according to IEC | 3NA3822 (63 A) | 3NA3824 (80 A) | 3NA3830 (100 A) |
| Fuse according to UL, class J | 60 A | 70 A | 90 A |
| Power loss without filter | 0.57 kW | 0.70 kW | 0.82 kW |
| Power loss with filter | 0.58 kW | 0.71 kW | 0.83 kW |
| Required cooling air flow | 55 l/s | 55 l/s | 55 l/s |
| Weight without filter | 16 kg | 16 kg | 17 kg |
| Weight with filter | 17.5 kg | 17.5 kg | 18.5 kg |

Technical data

6.6 Technical data, 400 V inverters

Table 6- 24 PM240-2, IP20, frame size D, 380 V ... 480 V 3 AC

| | |
|-----------------------------------|---------------------------|
| Article No. without filter | 6SL3210-1PE27-5UL0 |
| Article No. with filter | 6SL3210-1PE27-5AL0 |
| LO base load power | 37 kW |
| LO base load input current | 70 A |
| LO base load output current | 75 A |
| HO base load power | 30 kW |
| HO base load input current | 62 A |
| HO base load output current | 60 A |
| Fuse according to IEC | 3NA3830 (100 A) |
| Fuse according to UL, class J | 100 A |
| Power loss without filter | 1.09 kW |
| Power loss with filter | 1.10 kW |
| Required cooling air flow | 55 l/s |
| Weight without filter | 17 kg |
| Weight with filter | 18.5 kg |

Table 6- 25 PM240-2, PT, frame size D, 380 V ... 480 V 3 AC

| | |
|-----------------------------------|---------------------------|
| Article No. without filter | 6SL3211-1PE27-5UL0 |
| Article No. with filter | 6SL3211-1PE27-5AL0 |
| LO base load power | 37 kW |
| LO base load input current | 70 A |
| LO base load output current | 75 A |
| HO base load power | 30 kW |
| HO base load input current | 62 A |
| HO base load output current | 60 A |
| Fuse according to IEC | 3NA3830 (100 A) |
| Fuse according to UL, class J | 100 A |
| Power loss without filter | 1.09 kW ¹⁾ |
| Power loss with filter | 1.10 kW ¹⁾ |
| Required cooling air flow | 55 l/s |
| Weight without filter | 20 kg |
| Weight with filter | 21.5 kg |

¹⁾ Approx. 1 kW through the heatsink

Table 6- 26 PM240-2, IP20, frame size E, 380 V ... 480 V 3 AC

| Article No. without filter | 6SL3210-1PE28-8UL0 | 6SL3210-1PE31-1UL0 |
|-------------------------------|--------------------|--------------------|
| Article No. with filter | 6SL3210-1PE28-8AL0 | 6SL3210-1PE31-1AL0 |
| LO base load power | 45 kW | 55 kW |
| LO base load input current | 86 A | 104 A |
| LO base load output current | 90 A | 110 A |
| HO base load power | 37 kW | 45 kW |
| HO base load input current | 78 A | 94 A |
| HO base load output current | 75 A | 90 A |
| Fuse according to IEC | 3NA3832 (125 A) | 3NA3836 (160 A) |
| Fuse according to UL, class J | 125 A | 150 A |
| Power loss without filter | 1.29 kW | 1.65 kW |
| Power loss with filter | 1.30 kW | 1.67 kW |
| Required cooling air flow | 83 l/s | 83 l/s |
| Weight without filter | 26 kg | 26 kg |
| Weight with filter | 28 kg | 28 kg |

Table 6- 27 PM240-2, PT, frame size E, 380 V ... 480 V 3 AC

| Article No. without filter | 6SL3211-1PE31-1UL0 |
|-------------------------------|-----------------------|
| Article No. with filter | 6SL3211-1PE31-1AL0 |
| LO base load power | 55 kW |
| LO base load input current | 104 A |
| LO base load output current | 110 A |
| HO base load power | 45 kW |
| HO base load input current | 94 A |
| HO base load output current | 90 A |
| Fuse according to IEC | 3NA3836 (160 A) |
| Fuse according to UL, class J | 150 A |
| Power loss without filter | 1.65 kW ¹⁾ |
| Power loss with filter | 1.67 kW ¹⁾ |
| Required cooling air flow | 83 l/s |
| Weight without filter | 30.5 kg |
| Weight with filter | 32 kg |

¹⁾ Approx. 1.4 kW through the heatsink

6.6 Technical data, 400 V inverters

Table 6- 28 PM240-2, IP20, frame size F, 380 V ... 480 V 3 AC

| Article No. without filter | 6SL3210-1PE31-5UL0 | 6SL3210-1PE31-8UL0 | 6SL3210-1PE32-1UL0 |
|-------------------------------|--------------------|--------------------|--------------------|
| Article No. with filter | 6SL3210-1PE31-5AL0 | 6SL3210-1PE31-8AL0 | 6SL3210-1PE32-1AL0 |
| LO base load power | 75 kW | 90 kW | 110 kW |
| LO base load input current | 140 A | 172 A | 198 A |
| LO base load output current | 145 A | 178 A | 205 A |
| HO base load power | 55 kW | 75 kW | 90 kW |
| HO base load input current | 117 A | 154 A | 189 A |
| HO base load output current | 110 A | 145 A | 178 A |
| Fuse according to IEC | 3NA3140 (200 A) | 3NA3142 (224 A) | 3NA3250 (300 A) |
| Fuse according to UL, class J | 200 A | 250 A | 300 A |
| Power loss without filter | 1.91 kW | 2.46 kW | 2.28 kW |
| Power loss with filter | 1.93 kW | 2.48 kW | 2.30 kW |
| Required cooling air flow | 153 l/s | 153 l/s | 153 l/s |
| Weight without filter | 57 kg | 57 kg | 61 kg |
| Weight with filter | 63 kg | 63 kg | 65 kg |

Table 6- 29 PM240-2, IP20, frame size F, 380 V ... 480 V 3 AC

| Article No. without filter | 6SL3210-1PE32-5UL0 |
|-------------------------------|--------------------|
| Article No. with filter | 6SL3210-1PE32-5AL0 |
| LO base load power | 132 kW |
| LO base load input current | 242 A |
| LO base load output current | 250 A |
| HO base load power | 110 kW |
| HO base load input current | 218 A |
| HO base load output current | 205 A |
| Fuse according to IEC | 3NA3252 (315 A) |
| Fuse according to UL, class J | 350 A |
| Power loss without filter | 2.98 kW |
| Power loss with filter | 3.02 kW |
| Required cooling air flow | 153 l/s |
| Weight without filter | 61 kg |
| Weight with filter | 65 kg |

Table 6- 30 PM240-2, PT, frame size F, 380 V ... 480 V 3 AC

| Article No. without filter | 6SL3211-1PE32-5UL0 |
|-------------------------------|-----------------------|
| Article No. with filter | 6SL3211-1PE32-5AL0 |
| LO base load power | 132 kW |
| LO base load input current | 242 A |
| LO base load output current | 250 A |
| HO base load power | 110 kW |
| HO base load input current | 218 A |
| HO base load output current | 205 A |
| Fuse according to IEC | 3NA3252 (315 A) |
| Fuse according to UL, class J | 350 A |
| Power loss without filter | 2.98 kW ¹⁾ |
| Power loss with filter | 3.02 kW ¹⁾ |
| Required cooling air flow | 153 l/s |
| Weight without filter | 63.5 kg |
| Weight with filter | 68 kg |

¹⁾ Approx. 2.6 kW through the heatsink

Table 6- 31 PM240-2, frame size G, 380 V ... 480 V 3 AC

| Article No. with filter class C3 | 6SL3210-1PE33-0CLO | 6SL3210-1PE33-7CLO | 6SL3210-1PE34-8CLO |
|----------------------------------|--------------------|--------------------|--------------------|
| Article No. with filter class C2 | 6SL3210-1PE33-0ALO | 6SL3210-1PE33-7ALO | 6SL3210-1PE34-8ALO |
| LO base load power | 160 kW | 200 kW | 250 kW |
| LO base load input current | 300 A | 365 A | 470 A |
| LO base load output current | 302 A | 370 A | 477 A |
| HO base load power | 132 kW | 160 kW | 200 kW |
| HO base load input current | 275 A | 330 A | 400 A |
| HO base load output current | 250 A | 302 A | 370 A |
| Fuse according to IEC | 3NA3254 (355 A) | 3NA3260 (400 A) | 3NA3372 (630 A) |
| Fuse according to UL, class J | 400 A | 500 A | 600 A |
| Fuse according to IEC/UL | 3NE1334-2 (500A) | 3NE1334-2 (500A) | 3NE1436-2 (630A) |
| Power loss with filter class C3 | 3.67 kW | 4.62 kW | 6.18 kW |
| Power loss with filter class C2 | 3.67 kW | 4.62 kW | 6.18 kW |
| Required cooling air flow | 210 l/s | 210 l/s | 210 l/s |
| Weight with filter class C3 | 105 kg | 113 kg | 120 kg |
| Weight with filter class C2 | 107 kg | 114 kg | 120 kg |

6.6.3 Current derating depending on the pulse frequency, 400 V inverters

| Article number | LO power [kW] | Pulse frequency [kHz] | | | | | | | |
|------------------------|---------------|---------------------------------|-------------|-------|-------|------|------|------|------|
| | | 2 | 4 *) | 6 | 8 | 10 | 12 | 14 | 16 |
| | | LO base load output current [A] | | | | | | | |
| 6SL3210-1PE11-8 . L1 | 0.55 | 1.7 | 1.7 | 1.4 | 1.2 | 1 | 0.9 | 0.8 | 0.7 |
| 6SL3210-1PE12-3 . L1 | 0.75 | 2.2 | 2.2 | 1.9 | 1.5 | 1.3 | 1.1 | 1 | 0.9 |
| 6SL3210-1PE13-2 . L1 | 1.1 | 3.1 | 3.1 | 2.6 | 2.2 | 1.9 | 1.6 | 1.4 | 1.2 |
| 6SL3210-1PE14-3 . L1 | 1.5 | 4.1 | 4.1 | 3.5 | 2.9 | 2.5 | 2.1 | 1.8 | 1.6 |
| 6SL3210-1PE16-1 . L1 | 2.2 | 5.9 | 5.9 | 5 | 4.1 | 3.5 | 3 | 2.7 | 2.4 |
| 6SL321 . -1PE18-0 . L1 | 3 | 7.7 | 7.7 | 6.5 | 5.4 | 4.6 | 3.9 | 3.5 | 3.1 |
| 6SL3210-1PE21-1 . L0 | 4 | 10.2 | 10.2 | 8.7 | 7.1 | 6.1 | 5.1 | 4.6 | 4.1 |
| 6SL3210-1PE21-4 . L0 | 5.5 | 13.2 | 13.2 | 11.2 | 9.2 | 7.9 | 6.6 | 5.9 | 5.3 |
| 6SL321 . -1PE21-8 . L0 | 7.5 | 18 | 18 | 15.3 | 12.6 | 10.8 | 9 | 8.1 | 7.2 |
| 6SL3210-1PE22-7 . L0 | 11 | 26 | 26 | 22.1 | 18.2 | 15.6 | 13 | 11.7 | 10.4 |
| 6SL321 . -1PE23-3 . L0 | 15 | 32 | 32 | 27.2 | 22.4 | 19.2 | 16 | 14.4 | 12.8 |
| 6SL3210-1PE23-8 . L0 | 18.5 | 38 | 38 | 32.3 | 26.6 | 22.8 | 19 | 17.1 | 15.2 |
| 6SL3210-1PE24-5 . L0 | 22 | 45 | 45 | 38.3 | 31.5 | 27 | 22.5 | 20.3 | 18 |
| 6SL3210-1PE26-0 . L0 | 30 | 60 | 60 | 51 | 42 | 36 | 30 | 27 | 24 |
| 6SL321 . -1PE27-5 . L0 | 37 | 75 | 75 | 63.8 | 52.5 | 45 | 37.5 | 33.8 | 30 |
| 6SL3210-1PE28-8 . L0 | 45 | 90 | 90 | 76.5 | 63 | 54 | 45 | 40.5 | 36 |
| 6SL321 . -1PE31-1 . L0 | 55 | 110 | 110 | 93.5 | 77 | --- | --- | --- | --- |
| 6SL3210-1PE31-5 . L0 | 75 | 145 | 145 | 123.3 | 101.5 | --- | --- | --- | --- |
| 6SL3210-1PE31-8 . L0 | 90 | 178 | 178 | 151.3 | 124.6 | --- | --- | --- | --- |
| Article number | | Pulse frequency [kHz] | | | | | | | |
| | | 2 *) | 4 | 6 | 8 | 10 | 12 | 14 | 16 |
| | | LO base load output current [A] | | | | | | | |
| 6SL3210-1PE32-1 . L0 | 110 | 205 | 143.5 | --- | --- | --- | --- | --- | --- |
| 6SL321 . -1PE32-5 . L0 | 132 | 250 | 175 | --- | --- | --- | --- | --- | --- |
| 6SL3210-1PE33-0AL0 | 160 | 302 | 211.4 | 151 | 120.8 | --- | --- | --- | --- |
| 6SL3210-1PE33-7AL0 | 200 | 370 | 259 | 185 | 148 | --- | --- | --- | --- |
| 6SL3210-1PE34-8AL0 | 250 | 477 | 333.9 | 238.5 | 190.8 | --- | --- | --- | --- |

*) Factory setting

The permissible motor cable length depends on the particular cable type and the pulse frequency that has been selected

6.7 Technical data, 690 V inverters

Motors for 690 V Power Modules

For the 690 V Power Modules, induction motors are permissible in the range from 50 % ... 150 % of the inverter power without any restrictions.



Note

Motors for inverter operation

Only use motors that are suitable for operation with inverters with a DC link.

For 690 V Power Modules, motors with a suitable insulation system for 690 V inverter operation are required (e.g. PREMIUM).

6.7.1 General data, 690 V inverters

| Property | Version |
|--|---|
| Line voltage | <ul style="list-style-type: none"> for systems according to IEC: 500 V ... 690 V 3 AC \pm 10% (in operation -20% < 1 min) for systems according to UL 500 V ... 600 V 3 AC \pm 10% (in operation -20% < 1 min) filtered devices only with Slash Rating (600Y/347V AC) |
| Line supply configurations | Grounded TN/TT line supplies or non-grounded IT line supplies  Permissible line supplies (Page 50) |
| Line impedance | No restrictions |
| Power factor λ | > 0.9 |
| Output voltage | 0 V 3 AC ... 0.95 x input voltage (max.) |
| Input frequency | 50 Hz ... 60 Hz, \pm 3 Hz |
| Output frequency | 0 ... 550 Hz, depending on the control mode |
| Inrush current | < LO base load input current |
| Overvoltage category according to EN 61800-5-1 | III for line supplies |
| Pulse frequency | 2 kHz (factory setting), can be adjusted to 4 kHz Adjustable in steps of 2 kHz.  Current reduction as a function of the pulse frequency (Page 115) If you increase the pulse frequency, the inverter reduces the maximum output current. |
| Short-circuit current (SCCR) and branch protection | Maximum permissible line short-circuit current \leq 100 kA rms Minimum required short-circuit current \geq 10 kA rms The length of the connecting cable from the line to the inverter may not reduce the minimum short-circuit current  Branch protection and short-circuit strength according to UL and IEC https://support.industry.siemens.com/cs/ww/en/view/109479152 |
| Braking methods | DC braking, compound braking, dynamic braking with integrated braking chopper |
| Degree of protection according to EN 60529 | IP20; must be installed in a control cabinet |
| Protection class according to EN 61800-5-1 | The inverters are devices with protection class I |
| Touch protection according to EN 50274 | DGUV regulation 3 when used for the intended purpose |
| Cooling in compliance with EN 60146 | Forced air cooling AF |

Dependent on the input voltage and output power

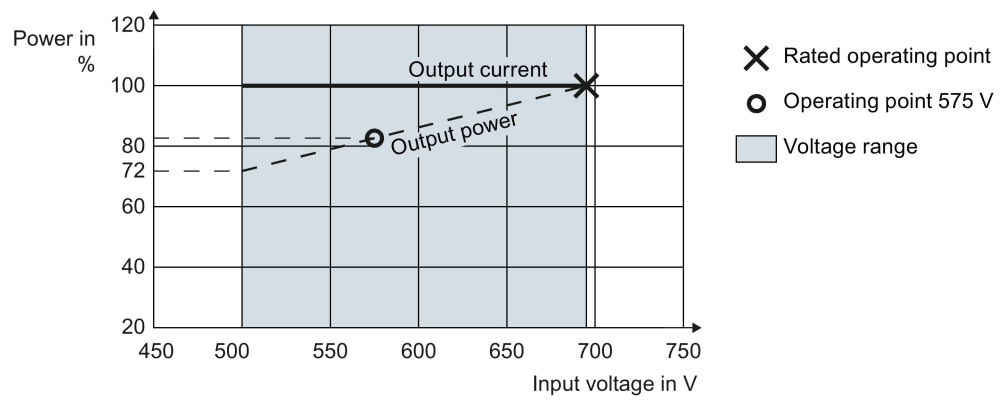

6.7.2 Specific technical data, 690 V inverters

Table 6- 32 PM240-2, IP20, frame size D, 500 V ... 690 V 3 AC

| Article No. - without filter | 6SL3210-1PH21-4UL0 | 6SL3210-1PH22-0UL0 | 6SL3210-1PH22-3UL0 |
|-------------------------------|--------------------|---------------------|---------------------|
| Article No. - with filter | 6SL3210-1PH21-4AL0 | 6SL3210-1PH22 -0AL0 | 6SL3210-1PH22 -3AL0 |
| LO base load power | 11 kW | 15 kW | 18.5 kW |
| LO base load input current | 14 A | 18 A | 22 A |
| LO base load output current | 14 A | 19 A | 23 A |
| HO base load power | 7.5 kW | 11 kW | 15 kW |
| HO base load input current | 11 A | 14 A | 20 A |
| HO base load output current | 11 A | 14 A | 19 A |
| Fuse according to IEC | 3NA3807-6 (20 A) | 3NA3810-6 (25 A) | 3NA3812-6 (32 A) |
| Fuse according to UL, class J | 20 A | 25 A | 30 A |
| Power loss without filter | 0.35 kW | 0.44 kW | 0.52 kW |
| Power loss with filter | 0.35 kW | 0.45 kW | 0.52 kW |
| Required cooling air flow | 55 l/s | 55 l/s | 55 l/s |
| Weight without filter | 17 kg | 17 kg | 17 kg |
| Weight with filter | 18.5 kg | 18.5 kg | 18.5 kg |

Table 6- 33 PM240-2, IP20, frame size D, 500 V ... 690 V 3 AC

| Article No. - without filter | 6SL3210-1PH22-7UL0 | 6SL3210-1PH23-5UL0 | 6SL3210-1PH24-2UL0 |
|-------------------------------|--------------------|---------------------|--------------------|
| Article No. - with filter | 6SL3210-1PH22-7AL0 | 6SL3210-1PH23 -5AL0 | 6SL3210-1PH24-2AL0 |
| LO base load power | 22 kW | 30 kW | 37 kW |
| LO base load input current | 25 A | 33 A | 40 A |
| LO base load output current | 27 A | 35 A | 42 A |
| HO base load power | 18.5 kW | 22 kW | 30 kW |
| HO base load input current | 24 A | 28 A | 36 A |
| HO base load output current | 23 A | 27 A | 35 A |
| Siemens fuse according to IEC | 3NA3817-6KJ (40 A) | 3NA3820-6KJ (50 A) | 33NA3822-6 (63 A) |
| Fuse according to UL, class J | 35 A | 45 A | 60 A |
| Power loss without filter | 0.60 kW | 0.77 kW | 0.93 kW |
| Power loss with filter | 0.60 kW | 0.78 kW | 0.94 kW |
| Required cooling air flow | 55 l/s | 55 l/s | 55 l/s |
| Weight without filter | 17 kg | 17 kg | 17 kg |
| Weight with filter | 18.5 kg | 18.5 kg | 18.5 kg |

Table 6- 34 PM240-2, IP20, frame size E, 500 V ... 690 V 3 AC

| Article No. - without filter | 6SL3210-1PH25-2UL0 | 6SL3210-1PH26-2UL0 |
|-------------------------------|--------------------|--------------------|
| Article No. - with filter | 6SL3210-1PH25-2AL0 | 6SL3210-1PH26-2AL0 |
| LO base load power | 45 kW | 55 kW |
| LO base load input current | 50 A | 59 A |
| LO base load output current | 52 A | 62 A |
| HO base load power | 37 kW | 45 kW |
| HO base load input current | 44 A | 54 A |
| HO base load output current | 42 A | 52 A |
| Siemens fuse according to IEC | 3NA3824-6 (80A) | 3NA3824-6 (80A) |
| Fuse according to UL, class J | 80 A | 80 A |
| Power loss without filter | 1.07 kW | 1.30 kW |
| Power loss with filter | 1.08 kW | 1.31 kW |
| Required cooling air flow | 83 l/s | 83 l/s |
| Weight without filter | 26 kg | 26 kg |
| Weight with filter | 28 kg | 28 kg |

Table 6- 35 PM240-2, IP20, frame size F, 500 V ... 690 V 3 AC

| Article No. - without filter | 6SL3210-1PH28-0UL0 | 6SL3210-1PH31-0UL0 | 6SL3210-1PH31-2UL0 |
|-------------------------------|--------------------|--------------------|--------------------|
| Article No. - with filter | 6SL3210-1PH28-0AL0 | 6SL3210-1PH31-0AL0 | 6SL3210-1PH31-2AL0 |
| LO base load power | 75 kW | 90 kW | 110 kW |
| LO base load input current | 78 A | 97 A | 111 A |
| LO base load output current | 80 A | 100 A | 115 A |
| HO base load power | 55 kW | 75 kW | 90 kW |
| HO base load input current | 66 A | 85 A | 106 A |
| HO base load output current | 62 A | 80 A | 100 A |
| Siemens fuse according to IEC | 3NA3830-6 (100 A) | 3NA3132-6 (125 A) | 3NA3136-6 (160 A) |
| Fuse according to UL, class J | 100 A | 125 A | 150 A |
| Power loss without filter | 1.37 kW | 1.74 kW | 1.95 kW |
| Power loss with filter | 1.38 kW | 1.76 kW | 1.97 kW |
| Required cooling air flow | 153 l/s | 153 l/s | 153 l/s |
| Weight without filter | 60 kg | 60 kg | 60 kg |
| Weight with filter | 64 kg | 64 kg | 64 kg |

Technical data

6.7 Technical data, 690 V inverters

Table 6- 36 PM240-2, IP20, frame size F, 500 V ... 690 V 3 AC

| | |
|-------------------------------------|---------------------------|
| Article No. - without filter | 6SL3210-1PH31-4UL0 |
| Article No. - with filter | 6SL3210-1PH31-4AL0 |
| LO base load power | 132 kW |
| LO base load input current | 137 A |
| LO base load output current | 142 A |
| HO base load power | 110 kW |
| HO base load input current | 122 A |
| HO base load output current | 115 A |
| Siemens fuse according to IEC | 3NA3140-6 (200 A) |
| Fuse according to UL, class J | 200 A |
| Power loss without filter | 2.48 kW |
| Power loss with filter | 2.51 kW |
| Required cooling air flow | 153 l/s |
| Weight without filter | 60 kg |
| Weight with filter | 64 kg |

Table 6- 37 PM240-2, frame size G, 500 V ... 690 V 3 AC

| Article No. with filter | 6SL3210-1PH31-7CLO | 6SL3210-1PH32-1CLO | 6SL3210-1PH32-5CLO |
|--------------------------------|---------------------------|---------------------------|---------------------------|
| LO base load power | 160 kW | 200 kW | 250 kW |
| LO base load input current | 170 A | 205 A | 250 A |
| LO base load output current | 171 A | 208 A | 250 A |
| HO base load power | 132 kW | 160 kW | 200 kW |
| HO base load input current | 160 A | 185 A | 225 A |
| HO base load output current | 144 A | 171 A | 208 A |
| Fuse according to the IEC/UL | 3NE1227-0 (250A) | 3NE1230-0 (315A) | 3NE1331-0 (350A) |
| Power loss | 2.94 kW | 3.70 kW | 4.64 kW |
| Required cooling air flow | 210 l/s | 210 l/s | 210 l/s |
| Weight | 114 kg | 114 kg | 114 kg |

6.7.3 Current derating depending on the pulse frequency, 690 V inverters

| Article number | LO power [kW] | Pulse frequency [kHz] | |
|------------------------|---------------|---------------------------------|-------|
| | | 2 *) | 4 |
| | | LO base load output current [A] | |
| 6SL3210-1PH21-4 . L0 | 11 | 14 | 8.4 |
| 6SL3210-1PH22-0 . L0 | 15 | 19 | 11.4 |
| 6SL3210-1PH22-3 . L0 | 18.5 | 23 | 13.8 |
| 6SL3210-1PH22-7 . L0 | 22 | 27 | 16.2 |
| 6SL3210-1PH23-5 . L0 | 30 | 35 | 21 |
| 6SL321 . -1PH24-2 . L0 | 37 | 42 | 25.2 |
| 6SL3210-1PH25-2 . L0 | 45 | 52 | 31.2 |
| 6SL321 . -1PH26-2 . L0 | 55 | 62 | 37.2 |
| 6SL3210-1PH28-0 . L0 | 75 | 80 | 48 |
| 6SL3210-1PH31-0 . L0 | 90 | 100 | 60 |
| 6SL3210-1PH31-2 . L0 | 110 | 115 | 69 |
| 6SL3210-1PH31-4 . L0 | 132 | 142 | 85.2 |
| 6SL3210-1PH31-7CLO | 160 | 171 | 102.6 |
| 6SL3210-1PH32-1CLO | 200 | 208 | 124.8 |
| 6SL3210-1PH32-5CLO | 250 | 250 | 150 |

*) Factory setting

The permissible motor cable length depends on the particular cable type and the pulse frequency that has been selected

6.8 Restrictions for special ambient conditions

Maximum current at low speeds

NOTICE

Overheating the inverter due to unsuitable load

Loading the inverter with a high output current and at the same time with a low output frequency can cause the current-conducting components in the inverter to overheat. Excessively high temperatures can damage the inverter or have a negative impact on the inverter service life.

- Never operate the inverter continuously with an output frequency = 0 Hz.
- Only operate the inverter in the permissible operating range.

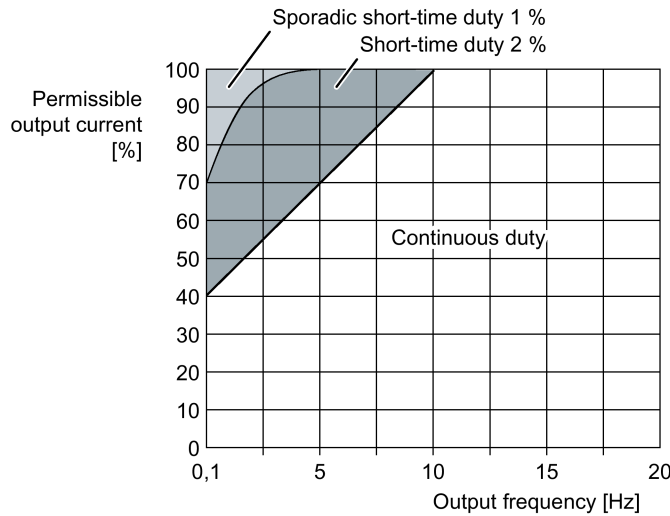

Figure 6-2 Permissible operating range of the inverter

- **Continuous operation:**
Operating state that is permissible for the complete operating time.
- **Short-time duty:**
Operating state that is permissible for less than 2 % of the operating time.
- **Sporadic short-time duty:**
Operating state that is permissible for less than 1 % of the operating time.

Current reduction as a function of the installation altitude and ambient temperature

At installation altitudes above 1000 m the permissible inverter output current is reduced.

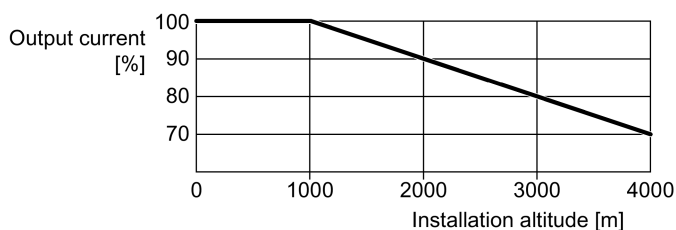

Figure 6-3 Current reduction as a function of the installation altitude

At installation altitudes above 1000 m, you can compensate the permissible inverter output current to a certain extent using the ambient temperature. The following tables contain the details.

Table 6- 38 Maximum permitted output current for loading according to LO

| Installation altitude [m] up to | Ambient temperature [°C] | | | | | | | | |
|---------------------------------|--|----|----|----|----|----|----|----|----|
| | 20 | 25 | 30 | 35 | 40 | 45 | 50 | 55 | 60 |
| | Output current in [%] when loading to LO | | | | | | | | |
| 1000 | 100 | | | | | 93 | 85 | 76 | 66 |
| 1500 | 100 | | | | 95 | 88 | 81 | 72 | 63 |
| 2000 | 100 | | | 97 | 90 | 83 | 77 | 68 | 59 |
| 2500 | 100 | | 98 | 91 | 85 | 79 | 72 | 64 | 56 |
| 3000 | 100 | 98 | 92 | 86 | 80 | 74 | 68 | 60 | 53 |
| 3500 | 98 | 92 | 86 | 81 | 75 | 69 | 64 | 57 | 50 |
| 4000 | 91 | 86 | 81 | 75 | 70 | 65 | 60 | 53 | 46 |

Table 6- 39 Maximum permitted output current when loading according to HO

| Installation altitude [m] up to | Ambient temperature [°C] | | | | | | | | |
|---------------------------------|--|----|----|----|----|----|----|----|----|
| | 20 | 25 | 30 | 35 | 40 | 45 | 50 | 55 | 60 |
| | Output current in [%] when loading to HO | | | | | | | | |
| 1000 | 100 | | | | | | | 87 | 74 |
| 1500 | 100 | | | | | | 95 | 83 | 70 |
| 2000 | 100 | | | | 99 | 95 | 90 | 78 | 67 |
| 2500 | 100 | | | 98 | 94 | 89 | 85 | 74 | 63 |
| 3000 | 100 | | 96 | 92 | 88 | 84 | 80 | 70 | 59 |
| 3500 | 98 | 94 | 90 | 86 | 83 | 79 | 75 | 65 | 56 |
| 4000 | 91 | 88 | 84 | 81 | 77 | 74 | 70 | 61 | 52 |

Also observe the maximum permissible ambient operating temperatures for the Control Unit and possibly the Operator Panel.

Permissible line supplies dependent on the installation altitude

- For installation altitudes ≤ 2000 m above sea level, it is permissible to connect the inverter to any of the line supplies that are specified for it.
- For installation altitudes 2000 m ... 4000 m above sea level, the following applies:
 - Connection to a TN line system with grounded neutral point is permissible.
 - TN systems with grounded line conductor are not permitted.
 - The TN line system with grounded neutral point can also be supplied using an isolation transformer.
 - The phase-to-phase voltage does not have to be reduced.

Note

Using Power Modules connected to TN line supplies with voltages ≥ 600 V for installation altitudes 2000 m ... 4000 m

For voltages ≥ 600 V, the TN line supply must have a grounded neutral point established using an isolating transformer.

6.9 Electromagnetic compatibility of variable-speed drives

EMC (electromagnetic compatibility) means that the devices function satisfactorily without interfering with other devices and without being disrupted by other devices. EMC applies when the emitted interference (emission level) and the interference immunity are matched with each other.

The product standard IEC/EN 61800-3 describes the EMC requirements placed on "Variable-speed drive systems".

A variable-speed drive system (or Power Drive System PDS) consists of the inverter as well as the associated electric motors and encoders including the connecting cables.

The driven machine is not part of the drive system.

Note

PDS as component of machines or systems

When you install PDS into machines or systems, additional measures may be required so that the product standards of these machines or systems is complied with. The machine or system builder is responsible for taking these measures.

Environments and categories

Environments

IEC/EN 61800-3 makes a distinction between the "first environment" and "second environment" - and defines different requirements for these environments.

- **First environment:**
Residential buildings or locations at which the PDS is directly connected to a public low-voltage supply without intermediate transformer.
- **Second environment:**
All industrial plant/systems or locations that are connected to the public grid through their own, dedicated transformer.

Categories

IEC/EN 61800-3 makes a distinction between four drive system categories:

- **Category C1:**
Drive systems for rated voltages < 1000 V for unrestricted use in the "first environment"
- **Category C2:**
Stationary PDS for rated voltages < 1000 V for operation in the "second environment".
Appropriately qualified personnel are required to install the PDS. An appropriately trained and qualified person has the necessary experience for installing and commissioning a PDS, including the associated EMC aspects.
Additional measures are required for operation in the "first environment".
- **Category C3:**
PDS for rated voltages < 1000 V - only for operation in the "second environment".
- **Category C4:**
PDS for IT line supplies for operation in complex systems in the "second environment".
An EMC plan is required.

6.9.1 Inverter applications

Inverters involve equipment used on a professional basis, deployed in certain areas of business and industry - and are not operated in the general public domain.



For an EMC-compliant installation, observe the information provided in the Configuration manual: EMC installation guideline (<http://support.automation.siemens.com/WW/view/en/60612658>).

The devices described there are intended for operation in the first and second environments. Conditions for operation in the respective environment are subsequently listed.

6.9.1.1 Operation in the Second Environment

Interference immunity

You do not have to take any additional measures regarding interference immunity.

Interference emission - operation in the second environment, Category C2

The drive system must comply with the following conditions in order to comply with the limit values of the second environment, Category C2:

- The drive system is installed by appropriately qualified personnel in compliance with EMC regulations - and the installation notes provided in the manual.
- You use a shielded motor cable with low capacitance.
- The pulse frequency is not higher than the value set in the factory.

- The drive system is connected to a TN or TT line supply.
- You comply with the permissible motor cable length.
 -  Length of the motor cable (Page 60).
- The inverters are equipped with a Category C2 line filter (internal or external).
 - **200 V inverter frame size FSA ... FSC**
Inverters with integrated filter are suitable for operation in the second environment, Category C2.
 - **200 V inverter frame size FSD ... FSF**
The inverters require an external filter, Category C2
 - **400 V inverter**
Inverters with integrated filter are suitable for operation in the second environment, Category C2.
 - **690 V inverter**
Inverters of frame sizes FSD and FSE with integrated filter are suitable for operation in the Second Environment, Category C2.
Inverters of frame sizes FSF and FSG with integrated filter are suitable for operation in the Second Environment, Category C3.

With the external filters, from Section  Line filter (Page 137), the inverters without integrated filter comply with the requirements of the Second Environment, Category C2 with reference to interference emission.

If you use inverters without integrated filter or a filter other than those mentioned above, then you are responsible for verifying that the interference emission is limited.

You can use a dedicated radio interference suppression filter for each inverter - or a common filter for several inverters.



Further information on unfiltered devices can be found on the Internet:

Compliance with EMC limits with unfiltered devices

(<https://support.industry.siemens.com/cs/ww/en/view/109750634>)

Interference emission - operation in the second environment, Category C4

When connected to IT line supplies, only filtered inverters are permissible. Use external filters without capacitors with respect to ground to limit symmetrical interference emission. When necessary, contact one of our Solution Partners

(<https://www.automation.siemens.com/solutionpartner/partnerfinder/Home/Index?country=DE&program=1&technology=19&lang=en>).

6.9.1.2 Operation in the First Environment

Interference immunity

You do not have to take any additional measures regarding interference immunity.

Interference emission - operation in the first environment, Category C2

In order that you may operate the drive system in the first environment, Category C2, then in addition to the requirements for use in the second environment, you must also observe the limit values related to harmonic currents.

Note

Maintaining the limit values for harmonic currents

With respect to the compliance with limits for harmonic currents, the EMC product standard EN61800-3 for PDS refers to compliance with standards EN 61000-3-2 and EN 61000-3-12.

Inverter with an LO base load power ≤ 1 kW:

It cannot be guaranteed that the limit values are complied with corresponding to IEC 61000-3-2. The installation person/company or company operating the professionally used device must obtain authorization from the grid operator to connect the device regarding the harmonic currents.



Typical harmonic currents (Page 123)

Inverters with an LO base load input current ≤ 16 A:

These devices are not subject to any limit values, and as a consequence can be connected to the public low-voltage grid without any prior consultation.

Inverters with an LO base load input current > 16 A and ≤ 75 A

The drive system is in compliance with IEC/EN 61000-3-12 under the following preconditions:

- FSC Power Module, input voltage 3 AC 200 ... 240 V: You use a 3% or 4% line reactor.
- FSD Power Module, input voltage 3 AC 200 ... 240 V: A line reactor is not required
- FSB/FSC Power Module, input voltage 3 AC 380 ... 480 V: You use a 3% or 4% line reactor.

- Power Module FSD, input voltage 380 ... 480 V 3 AC: A line reactor is not required

Note

Line reactor

Contact our Solution Partners

(<https://www.automation.siemens.com/solutionpartner/partnerfinder/Home/Index?country=DE&program=1&technology=19&lang=en>) for a line reactor.

- Short-circuit power S_{SC} at the connection point of the customer's system to the public grid, is greater than or equal to the value according to the following formula:

$$S_{SC} \geq 120 \times \sqrt{3} \times V_{in} \times LO \text{ base load input current}$$

Example: FSD inverter, 400 V, input current, 70 A:

$$S_{SC} \geq 120 \times \sqrt{3} \times 400 \text{ V} \times 70 \text{ A}$$

This corresponds to a low-voltage transformer with an apparent power rating of 300 kVA ... 400 kVA with $V_K = 4\% \dots 6\%$

The installation company or company operating the equipment is responsible for ensuring that this equipment is only connected at a connection point with an appropriate short-circuit power (fault level).

If these preconditions do not apply, then the installation company or company operating the device must obtain authorization from the grid operator to connect the device regarding the harmonic currents.

 Typical harmonic currents (Page 123)

Inverters with an LO base load current > 75A

There are no standard-related requirements for installing devices such as these. However, we recommend that the grid operator is informed when such a device is connected. 400 V inverters conform to EN 61000-3-12.

6.9.2 Typical harmonic currents

Table 6- 40 Typical harmonic currents (%) of the inverter

| Inverter | Harmonic number | | | | | | | |
|---|-----------------|-----|------|------|------|------|------|------|
| | 5th | 7th | 11th | 13th | 17th | 19th | 23rd | 25th |
| FSA ... FSC, 200 V, 400 V ¹⁾ | 54 | 39 | 11 | 5.5 | 5 | 3 | 2 | 2 |
| FSD ... FSF, 200 V ²⁾ | 28 | 14 | 8 | 6 | 5 | 4 | 3 | 3 |
| FSD ... FSG, 400 V ²⁾ | 37 | 21 | 7 | 5 | 4 | 3 | 3 | 2 |
| FSD ... FSG, 690 V ²⁾ | 34 | 18 | 8 | 5 | 4 | 3 | 3 | 2 |

¹⁾ Values relative to the LO input current for $V_K 1\%$

²⁾ Values relative to the LO input current

6.9.3 EMC limit values in South Korea

The following statements apply for filtered 400 V inverters, frame sizes FSD ... FSF.

All other inverters do not comply with the limit values.

이 기기는 업무용(A 급) 전자파적합기기로서 판매자 또는 사용자는 이 점을 주의하시기 바라며, 가정외의 지역에서 사용하는 것을 목적으로 합니다.
For sellers or users, please keep in mind that this device is an A-grade electromagnetic wave device. This device is intended to be used in areas other than home.

The EMC limit values to be observed for Korea correspond to the limit values of the EMC product standard for variable-speed electric drives EN 61800-3 of category C2 or the limit value class A, Group 1 to KN11.

By implementing appropriate additional measures, the limit values according to category C2 or limit value class A, Group 1, are observed.

Additional measures, such as the use of an additional RFI suppression filter (EMC filter), may be necessary.

In addition, measures for EMC-compliant configuration of the plant or system are described in detail in this manual.

You can find additional information about EMC-compliant configuration of the plant or system on the Internet:



EMC installation guideline

(<http://support.automation.siemens.com/WW/view/en/60612658>)

The final statement on compliance with the applicable standard is given by the respective label attached to the individual device.

Spare parts

Spare parts for frame sizes FSA ... FSC

| | Article number | | |
|-------------------------|----------------|--------------|--------------|
| | FSA | FSB | FSC |
| Accessory kit IP20*) | A5E33860501A | A5E33879111A | A5E33879131A |
| Accessory kit PT*) | A5E03396337 | A5E03395273 | A5E03343234 |

*) Included in the scope of delivery of the inverter
Can be ordered through the Siemens Repair Center

Spare parts for frame sizes FSD ... FSG

| | Article number | | | |
|---|------------------------|------------------------|------------------------|------------------------|
| | FSD | FSE | FSF | FSG |
| Set of small components | 6SL3200- 0SK08-0AA0 | 6SL3200- 0SK08-0AA0 | 6SL3200- 0SK08-0AA0 | 6SL3200- 0SK08-0AA0 |
| Mechanical kit | 6SL3200- 0SM13-0AA0 | 6SL3200- 0SM14-0AA0 | 6SL3200- 0SM15-0AA0 | 6SL3200- 0SM16-0AA0 |
| Fan kit, IP20 devices | 6SL3200- 0SF25-0AA0 | 6SL3200- 0SF27-0AA0 | 6SL3200- 0SF28-0AA0 | 6SL3200- 0SF18-0AA0 |
| Fan kit, PT de- vices | 6SL3200- 0SF25-0AA0 | 6SL3200- 0SF27-0AA0 | 6SL3200- 0SF28-0AA0 | --- |
| Accessory kit / shield connec- tion kit | 6SL3262- 1AD01-0DA0 | 6SL3262- 1AE01-0DA0 | 6SL3262- 1AF01-0DA0 | 6SL3262- 1AG01-0DA0 |

Accessories

Available components

- Accessory kit / shield connection kit (includes the upper shield plate)
- Mounting frames for PT Power Modules
- Mounting grips for PT Power Modules - frame sizes FSD ... FSF
- Line reactors for frame sizes FSA ... FSC
Line reactors are not required for frame sizes FSD ... FSG.
- External line filters, Class B for frame sizes FSA ... FSC.
No Class B filters are available for frame sizes FSD ... FSG.
- Braking resistors
- Brake Relay or Safe Brake Relay for controlling a motor holding brake
- Output reactors
- Voltage limiter and du/dt filter

Connection components

Connection overview for the electrical components  Connection overview (Page 56).

8.1 Top shield plate - FSD ... FSG

The shield plate is included in the accessory kit / shield connection kit. Order numbers:

 Spare parts (Page 125)

Fasten the shield plate as shown in the graphic:

- FSD and FSE: 2 x M5 / 3 Nm
- FSF and FSG: 4 x M8 / 23 Nm

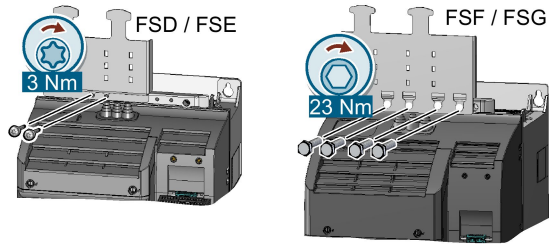

8.2 Mounting frames for PT power modules

Order numbers for mounting frames

- FSA: 6SL3260-6AA00-0DA0
- FSB: 6SL3260-6AB00-0DA0
- FSC: 6SL3260-6AC00-0DA0
- FSD: 6SL3200-0SM17-0AA0
- FSE: 6SL3200-0SM18-0AA0
- FSF: 6SL3200-0SM20-0AA0

All of the necessary nuts and seals are included in the scope of delivery.

| |
|--|
| NOTICE |
| Damage to devices due to defective mounting frame seals |
| If seals are defective, liquid or dirt can enter the control cabinet. This can damage or even destroy devices. |
| <ul style="list-style-type: none">• Check the seals for damage.• Replace any damaged seals. |

Dimension drawings for mounting frames, FSA ... FSC

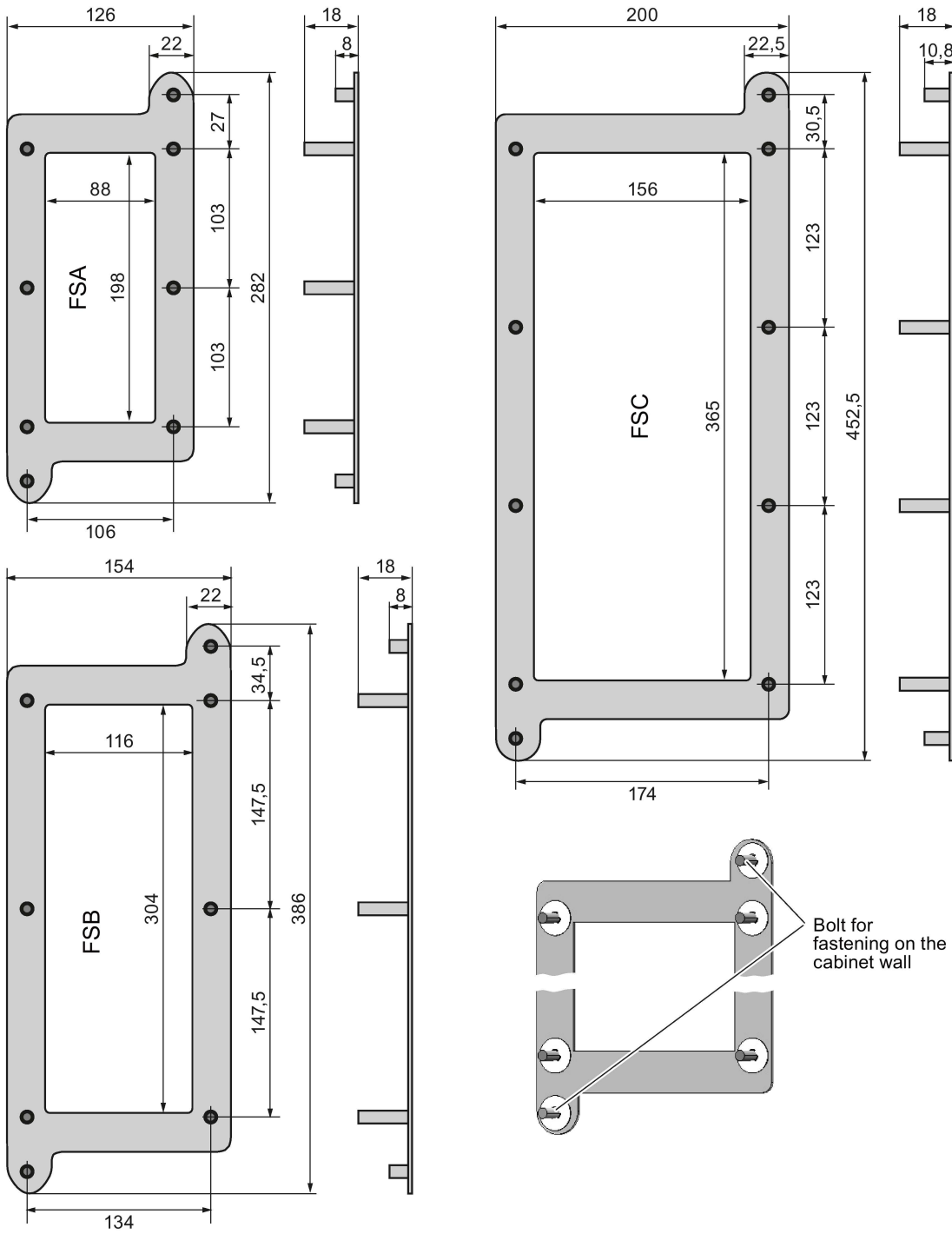

Dimension drawings for mounting frames, FSD ... FSF

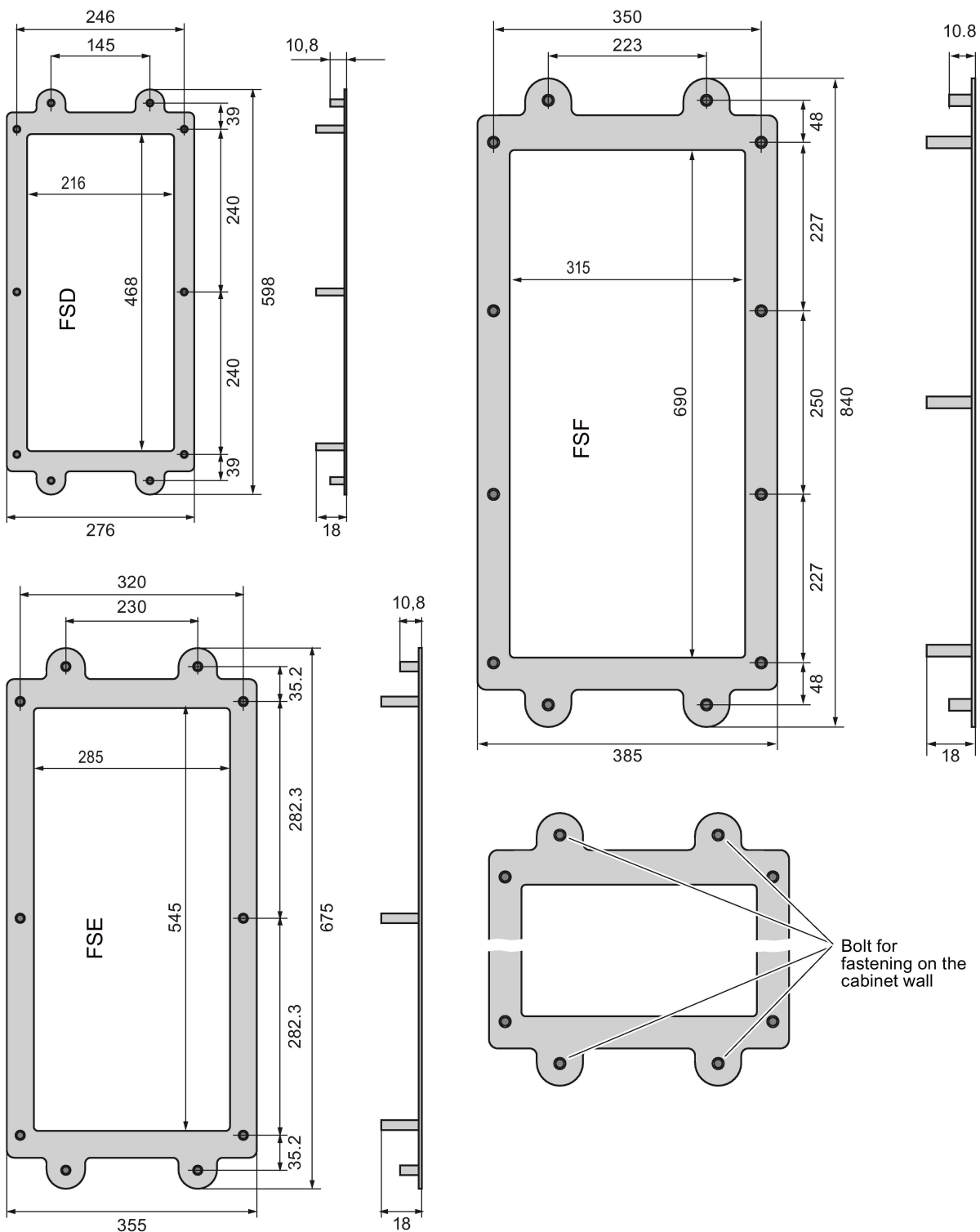

8.2.1 Mounting instructions with mounting frame

Procedure

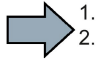

1. Proceed as follows to correctly mount the Power Module with the mounting frame:

2. 1. Prepare a cutout and holes in the control cabinet panel for the mounting frame corresponding to the dimension drawing.
2. 2. Insert the mounting frame from the rear of the control cabinet through the corresponding holes and fix it in place at the fixing screws for the control cabinet panel; tighten the two / four nuts by hand.
3. 3. Attach the seal to the inner side of the control cabinet (frame sizes FSA ... FSC only).
4. 4. Insert the Power Module and tighten the screws by hand.
5. 5. Mount the Power Module.
6. 6. Finally, tighten the screws with the following torques.
 - M5 screws: 3.5 Nm
 - M6 screws: 5.9 Nm



You have correctly installed the Power Module.

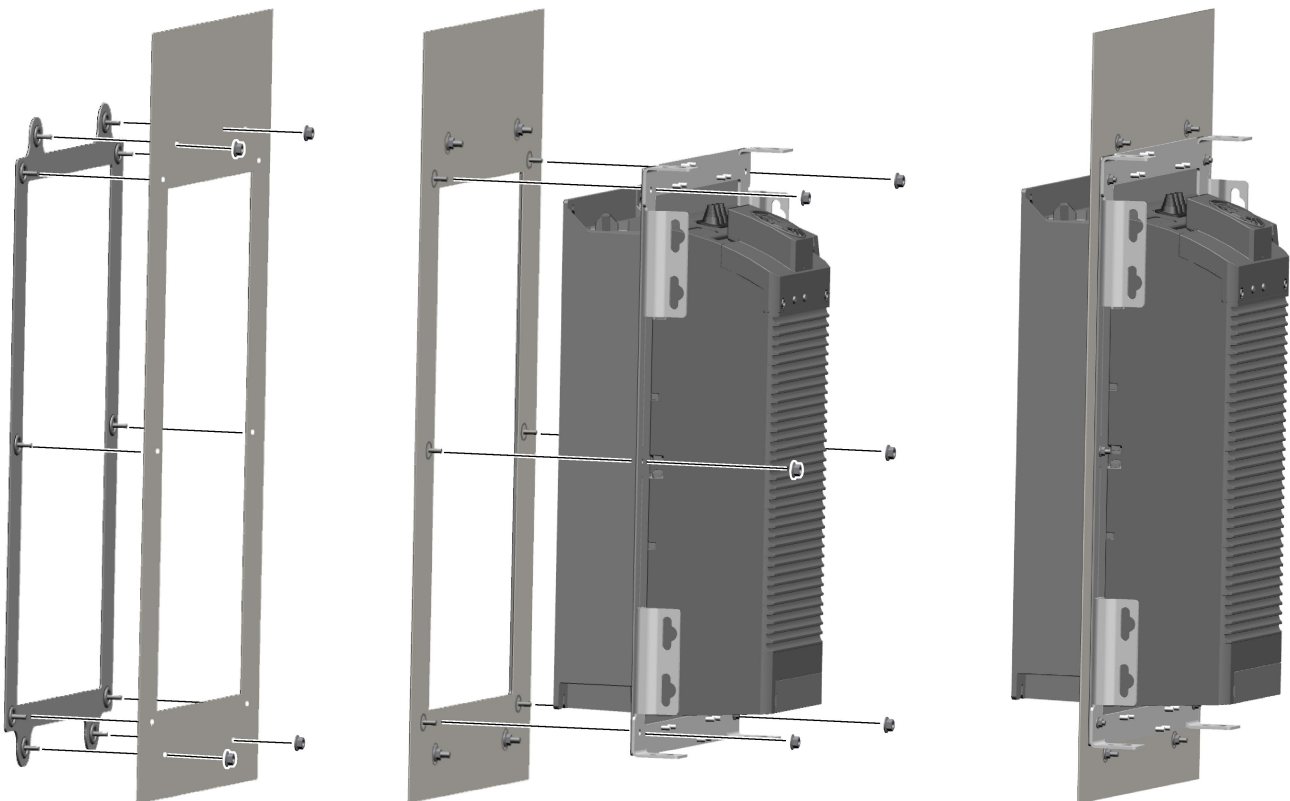

Figure 8-1 Installation instructions for the PT Power Modules with the optional mounting frame

8.3 Mounting grips for PT Power Modules

Mounting grips can be ordered for the PT Power Modules FSD ... FSF. The mounting grips enable the installation of the Power Module without hoisting gear.

Install the four hoisting grips as shown in the following image.

Article number: 6SL3200-0SM22-0AA0

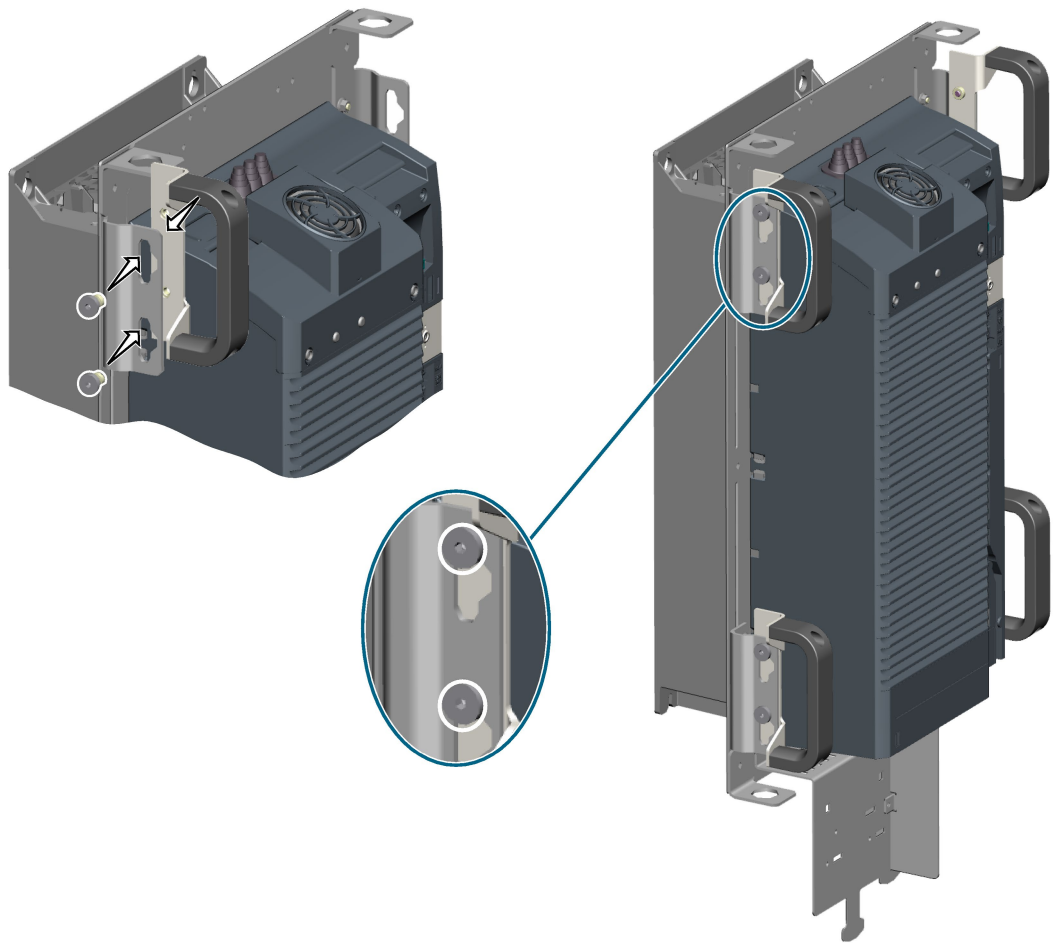

8.4 Line reactor

A line reactor protects the inverter when connected to dirty line supplies (line supply environment). A line reactor supports the overvoltage protection, smooths the harmonics in the line supply and buffers commutation dips.

Mounting position

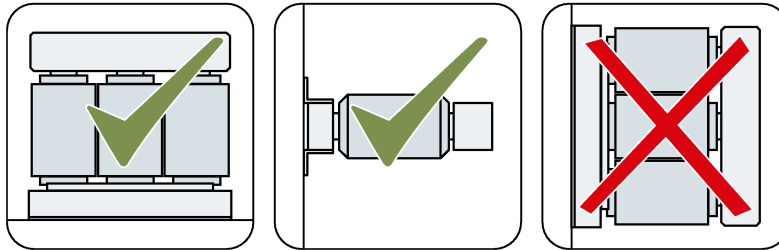

Clearances to other devices

Keep shaded areas free of any devices and components.

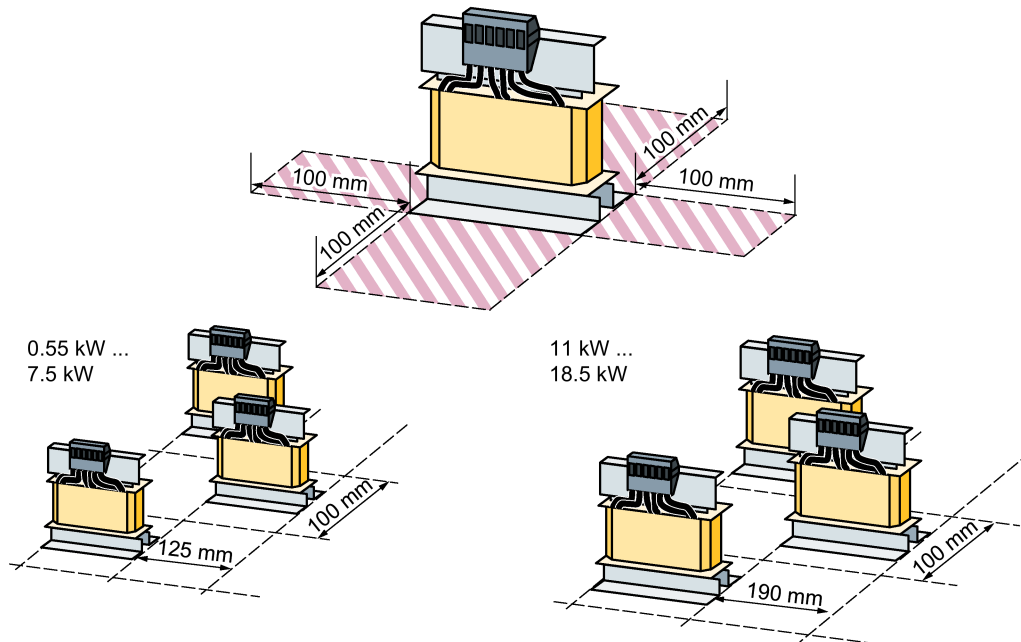
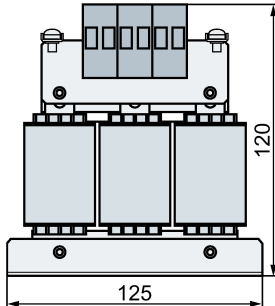
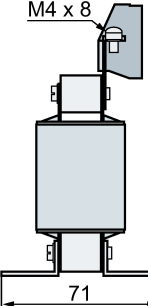
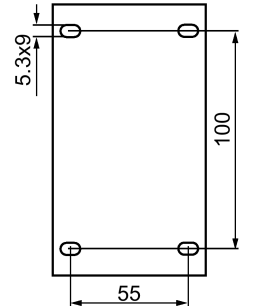
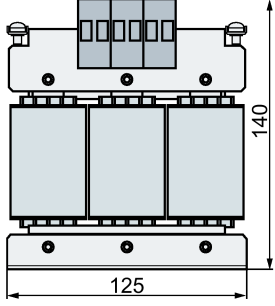
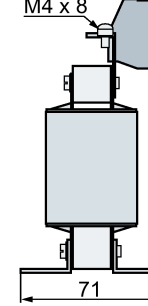
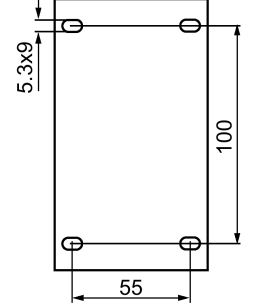
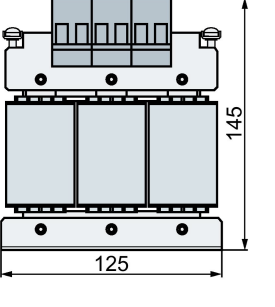
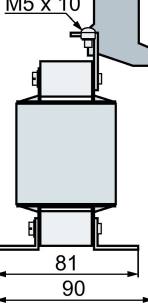
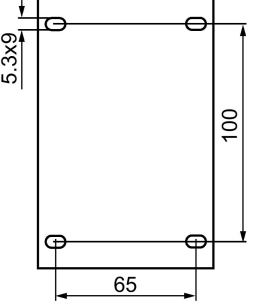
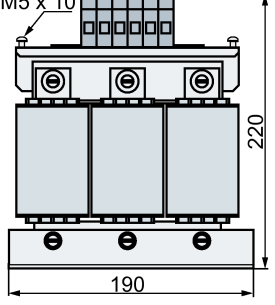
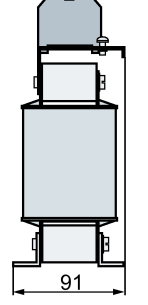
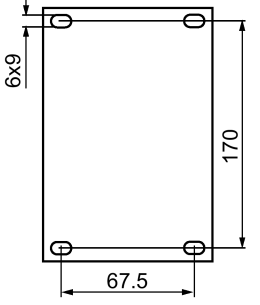

Figure 8-2 Clearances between the line reactors and other devices, examples for space-saving installation

Dimensions [mm] and drilling patterns

| | | | |
|--|---|---|---|
| <p>Article number 6SL3203-0CE13-2AA0</p> |  |  |  |
| <p>Article number 6SL3203-0CE21-0AA0</p> |  |  |  |
| <p>Article number 6SL3203-0CE21-8AA0</p> |  |  |  |
| <p>Article number 6SL3203-0CE23-8AA0</p> |  |  |  |

Mount the line reactor using M5 screws, nuts and washers. Tightening torque: 6 Nm

Assignment of line reactor to inverter:

 Table 8-2 Assignment table (Page 136)

8.4 Line reactor

Table 8- 1 Technical data of the line reactors

| Article number | In-ductance [mH] | Line/load connection | | PE connection | Weight [kg] |
|--------------------|------------------|------------------------|----------------|----------------------------|-------------|
| | | [mm ² / nM] | [AWG / lbf in] | [mm ² / lbf in] | |
| 6SL3203-OCE13-2AA0 | 2.5 | 2.5 / 0.8 | 14 / 7 | M4 [3 / 26.5] | 1.1 |
| 6SL3203-OCE21-0AA0 | 1 | 6 / 1.8 | 10 / 15.9 | M4 [3 / 26.5] | 2.1 |
| 6SL3203-OCE21-8AA0 | 0.5 | 6 / 1.8 | 10 / 15.9 | M5 [5 / 44.3] | 2.95 |
| 6SL3203-OCE23-8AA0 | 0.3 | 16 / 4 | 6 / 34.5 | M5 [5 / 44.3] | 7.80 |

The line reactors are designed to IP20 degree of protection.

Table 8- 2 Assignment table

| Line reactors | Power Module, 400 V | | Power Module, 200 V | |
|--------------------|---|-----|---|-----|
| 6SL3203-OCE13-2AA0 | 6SL3210-1PE11-8 . L1, 6SL3210-1PE12-3 . L1 6SL3210-1PE13-2 . L1 | FSA | 6SL3210-1PB13-0 . L0, 6SL321 . -1PB13-8 . L0 | FSA |
| 6SL3203-OCE21-0AA0 | 6SL3210-1PE14-3 . L1, 6SL321 . -1PE16-1 . L1 6SL321 . -1PE18-0 . L1 | FSA | 6SL3210-1PB15-5 . L0, 6SL3210-1PB17-4 . L0 6SL321 . -1PB21-0 . L0 | FSB |
| 6SL3203-OCE21-8AA0 | 6SL3210-1PE21-1 . L0, 6SL3210-1PE21-4 . L0 6SL321 . -1PE21-8 . L0 | FSB | 6SL3210-1PB21-4 . L0 6SL321 . -1PB21-8 . L0 | FSC |
| 6SL3203-OCE23-8AA0 | 6SL3210-1PE22-7 . L0, 6SL321 . -1PE23-3 . L0 | FSC | 6SL321 . -1PC22-2 . L0 6SL3210-1PC22-8 . L0 | FSC |

Line reactors for 1 AC 200 V

For inverters with 1 AC 200 V connection, rather than the line reactors listed above, you can also deploy the following or similar products:

- FSA:
NKE 10 / 2.93 (Block company)
- FSB
NKE 25 / 1.17 (Block company)
- FSC
NKE 35 / 1.46 (Block company)

The technical properties and statements made by the manufacturer apply.

8.5 Line filter

Dimensions for mounting the line filter

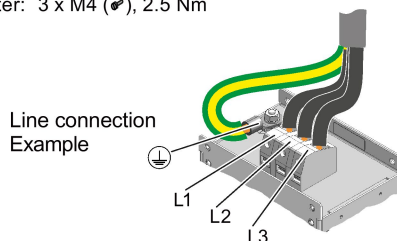
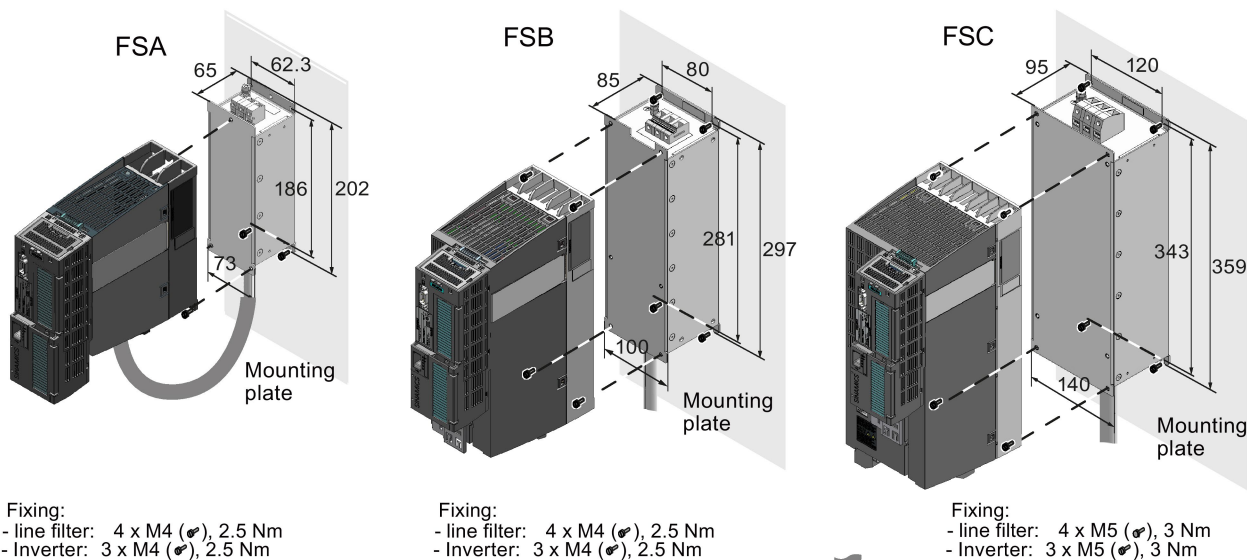

Table 8- 3 Technical data of the line filter (Class B)

| Article number | Power loss [W] | Connection | | Weight [kg] |
|--------------------|----------------|--|--|-------------|
| | | Line supply and Power Module | PE | |
| 6SL3203-0BE17-7BA0 | 13 | 2.5 mm ² / 0.8 Nm 14 AWG / 7 lbf in | 2.5 mm ² / 2 Nm 14 AWG / 17.7 lbf in | 1.75 |
| 6SL3203-0BE21-8BA0 | 22 | 6 mm ² / 1.8 Nm 10 AWG / 15.9 lbf in | 2.5 mm ² / 2 Nm 14 AWG / 17.7 lbf in | 4.0 |
| 6SL3203-0BE23-8BA0 | 50 | 16 mm ² / 4 Nm 6 AWG / 35.4 lbf in | 16 mm ² / 32 Nm 6 AWG / 26.5 lbf in | 7.3 |

Line filters are designed to IP20 degree of protection.

Table 8- 4 Assignment table

| Power Module, 400 V | | | Line filter (Class B) |
|---------------------|----------------------|-------|-----------------------|
| Frame size | Article number | Power | Article number |
| FSA | 6SL3210-1PE11-8UL1 | 0.55 | 6SL3203-0BE17-7BA0 |
| | 6SL3210-1PE12-3UL1 | 0.75 | |
| | 6SL3210-1PE13-2UL1 | 1.1 | |
| | 6SL3210-1PE14-3UL1 | 1.5 | |
| | 6SL3210-1PE16-1UL1 | 2.2 | |
| | 6SL321 . -1PE18-0UL1 | 3.0 | |
| FSB | 6SL3210-1PE21-1UL0 | 4.0 | 6SL3203-0BE21-8BA0 |
| | 6SL3210-1PE21-4UL0 | 5.5 | |
| | 6SL321 . -1PE21-8UL0 | 7.5 | |
| FSC | 6SL3210-1PE22-7UL0 | 11 | 6SL3203-0BE23-8BA0 |
| | 6SL321 . -1PE23-3UL0 | 15 | |

8.6 Braking resistor

The braking resistor enables loads with a large moment of inertia to be braked quickly. During braking of the motor and the load, excess energy is fed back to the converter. This causes the voltage to rise in the DC link. The converter transfers the excess energy to the externally mounted braking resistor.



WARNING

Fire caused by an unsuitable or incorrectly installed braking resistor

Using an unsuitable or improperly installed braking resistor can cause fires and smoke to develop. Fire and smoke development can cause severe personal injury or material damage.

- Only use braking resistors that are approved for the inverter.
- Install the braking resistor in accordance with regulations.
- Monitor the temperature of the braking resistor.

Mounting position

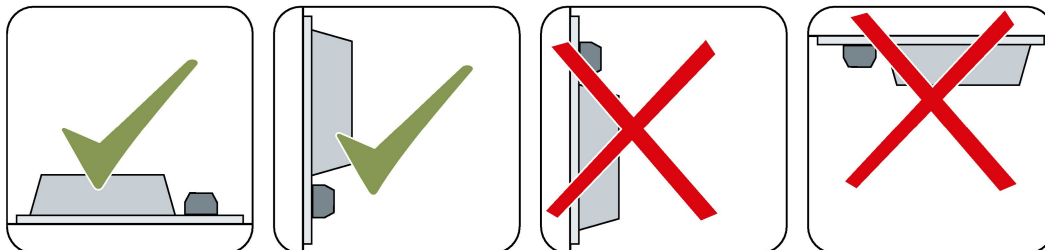

Mounting instructions

Mount the resistor on a heat resistant surface with a high thermal conductivity.

Do not cover the ventilation openings of the braking resistor.

You can mount the braking resistor either outside or inside the switchgear room. When mounted outside, the cooling air requirement for the switchgear room is lower.

Clearances to other devices

The following data are applicable for devices, frame sizes FSA ... FSC.

The clearances for braking resistors for devices, frame sizes FSD ... FSG are specified in the documentation, which is supplied with the braking resistor.

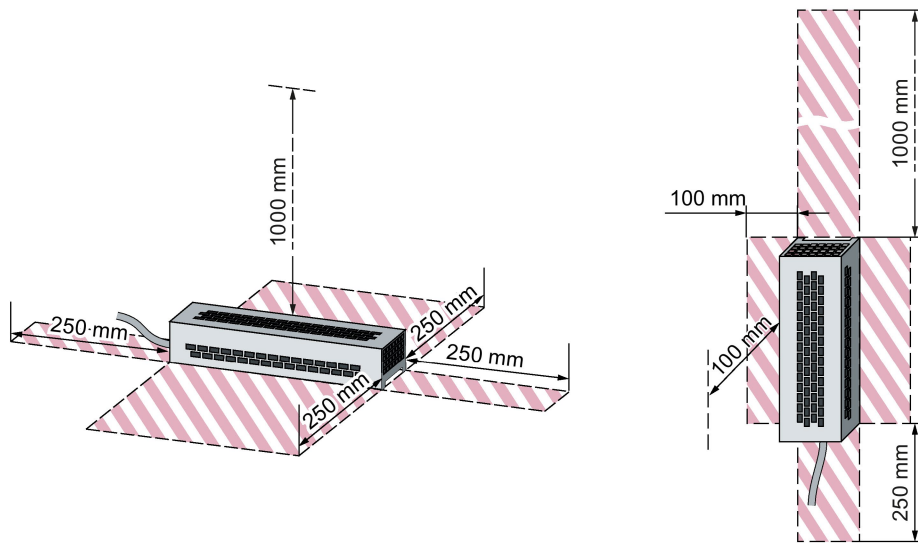

Figure 8-3 Minimum clearances for the braking resistor when mounting on a flat surface and for wall/panel mounting

Keep shaded areas free of any devices and components.

Dimensions and drilling patterns

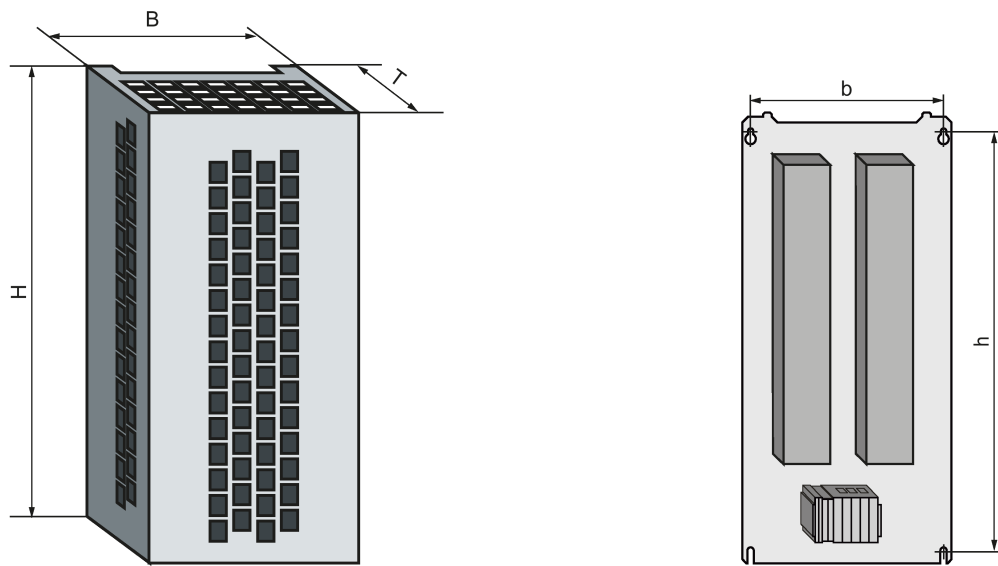

Figure 8-4 Braking resistor

Table 8- 5 Dimensions and weights

| Article number | Overall dimensions [mm] | | | Drilling dimensions [mm] | | Fixing/torque | Weight [kg] | Inverter frame size |
|--------------------------------|-------------------------|-----|-----|--------------------------|-----|---------------|-------------|---------------------|
| | W | H | D | b | h | | | |
| for 200 V inverters | | | | | | | | |
| JJY:023146720008 | 105 | 295 | 100 | 72 | 266 | M4 / 3 Nm | 1.5 | FSA |
| JJY:023151720007 | 105 | 345 | 100 | 72 | 316 | M4 / 3 Nm | 1.8 | FSB |
| JJY:02 3163720018 | 175 | 345 | 100 | 142 | 316 | M4 / 3 Nm | 2.7 | FSC |
| JJY:023433720001 | 250 | 490 | 140 | 217 | 460 | M5 / 6 Nm | 6.2 | FSC |
| JJY:023422620002 | 220 | 470 | 180 | 187 | 430 | M5 / 6 Nm | 7 | FSD |
| JJY:023423320001 | 220 | 560 | 180 | 187 | 500 | M5 / 6 Nm | 8.5 | FSE |
| JJY:023434020003 | 350 | 630 | 180 | 317 | 570 | M5 / 6 Nm | 13.5 | FSF |
| for 400 V inverters | | | | | | | | |
| 6SL3201-0BE14-3AA0 | 105 | 295 | 100 | 72 | 266 | M4 / 3 Nm | 1.5 | FSA |
| 6SL3201-0BE21-0AA0 | 105 | 345 | 100 | 72 | 316 | M4 / 3 Nm | 1.8 | FSA |
| 6SL3201-0BE21-8AA0 | 175 | 345 | 100 | 142 | 316 | M4 / 3 Nm | 2.7 | FSB |
| 6SL3201-0BE23-8AA0 | 250 | 490 | 140 | 217 | 460 | M5 / 6 Nm | 6.2 | FSC |
| JJY:023422620001 | 220 | 470 | 180 | 187 | 430 | M5 / 6 Nm | 7 | FSD |
| JJY:023424020001 | 220 | 610 | 180 | 187 | 570 | M5 / 6 Nm | 9.5 | FSD |
| JJY:023434020001 | 350 | 630 | 180 | 317 | 570 | M5 / 6 Nm | 13.5 | FSE |
| JJY:023454020001 ^{*)} | | | | | | | | FSF |
| • JJY:023422620001 | 220 | 470 | 180 | 187 | 430 | M5 / 6 Nm | 7 | (FSD) |
| • JJY:023434020001 | 350 | 630 | 180 | 317 | 570 | M5 / 6 Nm | 13.5 | (FSE) |
| JJY:023464020001 ^{*)} | | | | | | | | FSF |
| • JJY:023434020001 | 350 | 630 | 180 | 317 | 570 | M5 / 6 Nm | 13.5 | (FSE) |
| • JJY:023434020001 | 350 | 630 | 180 | 317 | 570 | M5 / 6 Nm | 13.5 | (FSE) |
| for 690 V inverters | | | | | | | | |
| JJY:023424020002 | 220 | 610 | 180 | 187 | 570 | M5 / 6 Nm | 9.5 | FSD |
| JJY:023434020002 | 350 | 630 | 180 | 317 | 570 | M5 / 6 Nm | 13.5 | FSE |
| JJY:023464020002 ^{*)} | | | | | | | | FSF |
| • JJY:023434020002 | 350 | 630 | 180 | 317 | 570 | M5 / 6 Nm | 13.5 | (FSE) |
| • JJY:023434020002 | 350 | 630 | 180 | 317 | 570 | M5 / 6 Nm | 13.5 | (FSE) |

Use the screws, nuts and washers when fixing the braking resistors

*) This braking resistor comprises two components, which must be connected in parallel on the plant/system side

8.6.1 Connecting a braking resistor

Some braking resistors have an integrated connection cable for the power connections (R1/R2) on the inverter. Thus, the length and cross-section of the connection cable are given.

For braking resistors without integrated connection cable, the maximum cable length is 10 m. The required conductor cross-sections are contained in the following tables.

The conductor cross-sections for the temperature monitoring are contained in the Operating Instructions of the Control Unit of your inverter.

Monitoring the temperature of the braking resistor without line contactor control

The braking contactors for FSA ... FSF inverters are intrinsically safe braking resistors and shut down in the event of overheating.

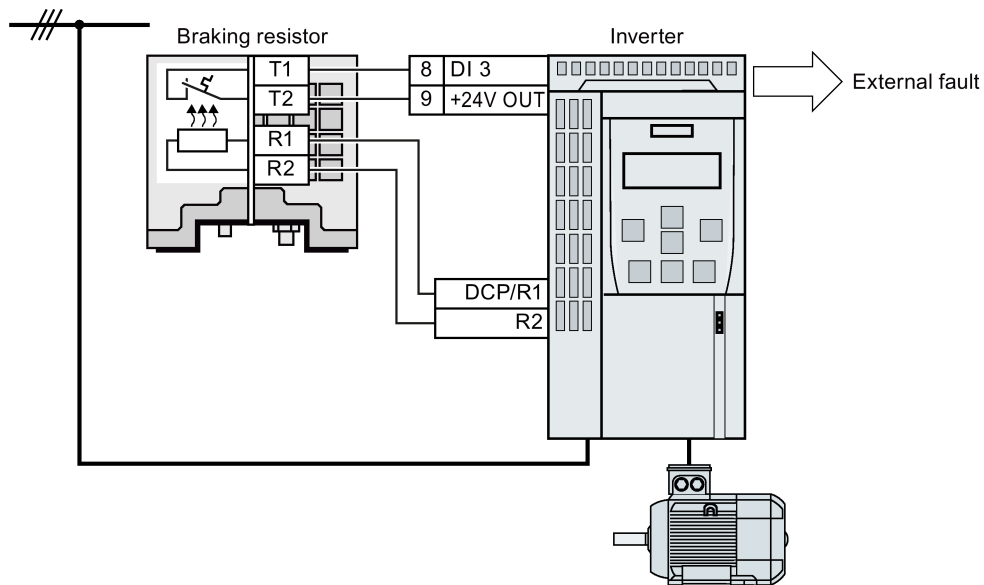

Figure 8-5 Connecting a braking resistor with temperature monitoring via digital input DI 3

Procedure



Proceed as follows to monitor the braking resistor temperature:

1. Connect the temperature monitoring system of the braking resistor (terminals T1 and T2 on the braking resistor) to a free digital input at the Control Unit of the inverter.
2. When commissioning the drive, define the function of the digital input used as external fault, using p2106.

As an example with temperature monitoring via digital input DI 3: p2106 = 722.3.



You have ensured that the temperature is monitored.

Monitoring the temperature of the braking resistor with line contactor control

With respect to FSG inverters, you not only have to monitor the temperature of the braking resistor but also have to ensure that the inverter is disconnected from the line in the event of a braking resistor overload. To do so, activate the line contactor control via a digital output of the inverter.

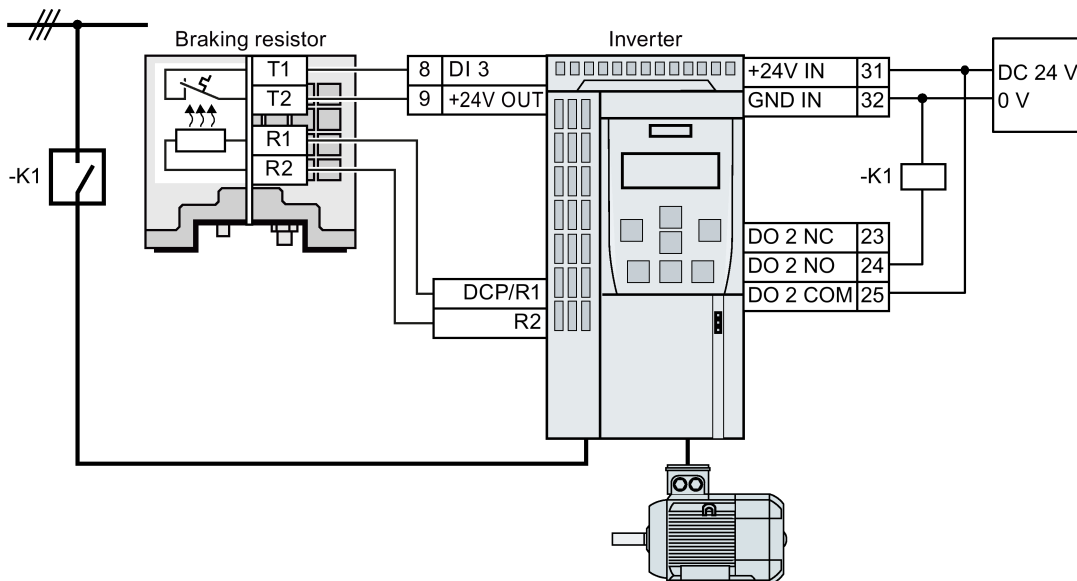

Figure 8-6 Connecting a braking resistor with temperature monitoring via digital input DI 3 and line contactor control (-K1) via digital output DO 2

Procedure



1.
2.

Proceed as follows to monitor the braking resistor temperature and activate the line contactor control:

1. Connect the temperature monitoring system of the braking resistor (terminals T1 and T2 on the braking resistor) to a free digital input at the Control Unit of the inverter.
2. When commissioning the drive, define the function of the digital input used as external fault, using p2106.

As an example with temperature monitoring via digital input DI 3: p2106 = 722.3.

3. Connect the digital output with the signal r0863.1 (line contactor control). For example for DO2 P0732 = 863.1



You have set the temperature monitoring and line contactor control.

8.6.2 Technical data of the braking resistor

For the inverters, use the following or comparable braking resistors. The technical properties and statements made by the manufacturer apply.

Note

Braking resistors FSD ... FSF

Only use braking resistors that are UL approved, and have successfully passed the "Abnormal Operation Test" according to UL 508.

FSG braking resistors

Make sure that the monitoring system for braking resistor temperature shuts down the inverter in the event of any overload.

Example:  Figure 8-6 Connecting a braking resistor with temperature monitoring via digital input DI 3 and line contactor control (-K1) via digital output DO 2 (Page 143)

Braking resistors for PM240-2, 200 V

Table 8- 6 Technical data

| Article number | Re-sistance | Maximum power, P _{max} | Connection R1 / R2 | Degree of protection | Power Module | |
|-------------------|-------------|---------------------------------|---|----------------------|--|------------|
| | | Rated power P _{db} | | Weight | Article numbers | Frame size |
| JJY:023146720008 | 200 Ω | 0.75 kW | Connecting cable integrated in the braking resistor | IP20 | 6SL3210-1PB13-0 . L0 6SL321 . -1PB13-8 . L0 | FSA |
| | | 37.5 W | | 1.5 kg | | |
| JJY:023151720007 | 68 Ω | 2.2 kW | | IP20 | 6SL3210-1PB15-5 . L0 6SL3210-1PB17-4 . L0 6SL321 . -1PB21-0 . L0 | FSB |
| | | 110 W | | 1.8 kg | | |
| JJY:02 3163720018 | 37 Ω | 4 kW | | IP20 | 6SL3210-1PB21-4 . L0 6SL321 . -1PB21-8 . L0 | FSC |
| | | 200 W | | 2.7 kg | | |
| JJY:023433720001 | 20 Ω | 7.5 kW | | IP20 | 6SL3210-1PC22-2 . L0 6SL3210-1PC22-8 . L0 | FSC |
| | | 375 W | | 6.2 | | |
| JJY:023422620002 | 7.5 Ω | 18.5 kW | 10 mm ² / 0.5 Nm 8 AWG / 4.5 lbf in | IP21 | 6SL3210-1PC24-2UL0 6SL3210-1PC25-4UL0 6SL321 . -1PC26-8UL0 | FSD |
| | | 930 W | | 7.0 kg | | |
| JJY:023423320001 | 4.5 Ω | 30 kW | 16 mm ² / 1.2 Nm 6 AWG / 10.6 lbf in | IP21 | 6SL3210-1PC28-0UL0 6SL321 . -1PC31-1UL0 | FSE |
| | | 1500 W | | 8.5 kg | | |
| JJY:023434020003 | 2.5 Ω | 55 kW | 16 mm ² / 1.2 Nm 6 AWG / 10.6 lbf in | IP21 | 6SL3210-1PC31-3UL0 6SL3210-1PC31-6UL0 6SL321 . -1PC31-8UL0 | FSF |
| | | 2750 W | | 13.5 kg | | |

Braking resistors for PM240-2, 400 V

Table 8- 7 Technical data

| Article number | Re-sistance | Maximum power, P_{max} | Connection R1 / R2 | Degree of protection | Power Module | |
|---|--------------|--------------------------|--|----------------------|--|------------|
| | | Rated power P_{db} | | Weight | Article numbers | Frame size |
| 6SL3201-0BE14-3AA0 | 370 Ω | 1.5 kW | 2.5 mm ² / 0.5 Nm 14 AWG / 4.5 lbf in | IP20 | 6SL3210-1PE11-8 . L1 6SL3210-1PE12-3 . L1 6SL3210-1PE13-2 . L1 6SL3210-1PE14-3 . L1 | FSA |
| | | 75 W | | 1.5 kg | | |
| 6SL3201-0BE21-0AA0 | 140 Ω | 4 kW | 2.5 mm ² / 0.5 Nm 14 AWG / 4.5 lbf in | IP20 | 6SL321 . -1PE16-1 . L1 6SL321 . -1PE18-0 . L1 | FSA |
| | | 200 W | | 1.8 kg | | |
| 6SL3201-0BE21-8AA0 | 75 Ω | 7.5 kW | 4 mm ² / 0.7 Nm 10 AWG / 6.2 lbf in | IP20 | 6SL3210-1PE21-1 . L0 6SL3210-1PE21-4 . L0 6SL321 . -1PE21-8 . L0 | FSB |
| | | 375 W | | 2.7 kg | | |
| 6SL3201-0BE23-8AA0 | 30 Ω | 18.5 kW | 4 mm ² / 0.7 Nm 10 AWG / 6.2 lbf in | IP20 | 6SL3210-1PE22-7 . L0 6SL321 . -1PE23-3 . L0 | FSC |
| | | 925 W | | 6.2 kg | | |
| JJY:023422620001 | 25 Ω | 22 kW | 10 mm ² / 0.8 Nm 8 AWG / 7.1 lbf in | IP21 | 6SL3210-1PE23-8 . L0 6SL3210-1PE24-5 . L0 | FSD |
| | | 1100 W | | 7.0 kg | | |
| JJY:023424020001 | 15 Ω | 37 kW | 10 mm ² / 0.8 Nm 8 AWG / 7.1 lbf in | IP21 | 6SL3210-1PE26-0 . L0 6SL321 . -1PE27-5 . L0 | FSD |
| | | 1850 W | | 9.5 kg | | |
| JJY:023434020001 | 10 Ω | 55 kW | 16 mm ² / 1.2 Nm 6 AWG / 4.5 lbf in | IP21 | 6SL3210-1PE28-8 . L0 6SL321 . -1PE31-1 . L0 | FSE |
| | | 2750 W | | 13.5 kg | | |
| JJY:023454020001 (JJY:023422620001 JJY:023434020001) | 7.1 Ω | 77 kW | 10 mm ² / 0.8 Nm 8 AWG / 7.1 lbf in 16 mm ² / 1.2 Nm 6 AWG / 4.5 lbf in | IP21 | 6SL3210-1PE31-5 . L0 6SL3210-1PE31-8 . L0 | FSF |
| | | 3850 W | | 20.5 kg | | |
| JJY:023464020001 (JJY:023434020001 JJY:023434020001) | 5 Ω | 110 kW | 16 mm ² / 1.2 Nm 6 AWG / 4.5 lbf in 16 mm ² / 1.2 Nm 6 AWG / 4.5 lbf in | IP21 | 6SL3210-1PE32-1 . L0 6SL321 . -1PE32-5 . L0 | FSF |
| | | 5500 W | | 27 kg | | |
| 6SL3000-1BE32-5AA0 | 2.2 Ω | 250 kW | 70 mm ² / M10 | IP00 | 6SL3210-1PE33-0 . L0 6SL3210-1PE33-7 . L0 6SL3210-1PE34-8 . L0 | FSG |
| | | 12.5 kW | | 120 kg | | |

Braking resistors for PM240-2, 690 V

Table 8- 8 Technical data

| Article number | Re-sistance | Maximum power, P_{max} | Connection R1 / R2 | Degree of protection | Power Module | |
|--|---------------|--------------------------|--|----------------------|--|------------|
| | | Rated power P_{db} | | Weight | Article Nos. | Frame size |
| JJY:023424020002 | 31 Ω | 37 kW | 10 mm ² / 0.8 Nm 8 AWG / 7.1 lbf in | IP21 | 6SL3210-1PH21-4 . L0 6SL3210-1PH22-0 . L0 6SL3210-1PH22-3 . L0 6SL3210-1PH22-7 . L0 6SL3210-1PH23-5 . L0 6SL321 . -1PH24-2 . L0 | FSD |
| | | 1850 W | | 9.5 kg | | |
| JJY:023434020002 | 21 Ω | 55 kW | 16 mm ² / 1.2 Nm 6 AWG / 4.5 lbf in | IP21 | 6SL3210-1PH25-2 . L0 6SL321 . -1PH26-2 . L0 | FSE |
| | | 2750 W | | 13.5 kg | | |
| JJY:023464020002 (JJY:023434020002 JJY:023434020002) | 10.5 Ω | 110 kW | 16 mm ² / 1.2 Nm 6 AWG / 10.6 lbf in | IP21 | 6SL3210-1PH28-0 . L0 6SL3210-1PH31-0 . L0 6SL3210-1PH31-2 . L0 6SL3210-1PH31-4 . L0 | FSF |
| | | 5500 W | | 27 kg | | |
| 6SL3000-1BH32-5AA0 | 4.9 Ω | 250 kW | 70 mm ² / M10 | IP00 | 6SL3210-1PH31-7CL0 6SL3210-1PH32-1CL0 6SL3210-1PH32-5CL0 | FSG |
| | | 12.5 kW | | 120 kg | | |

Load cycles for the braking resistors

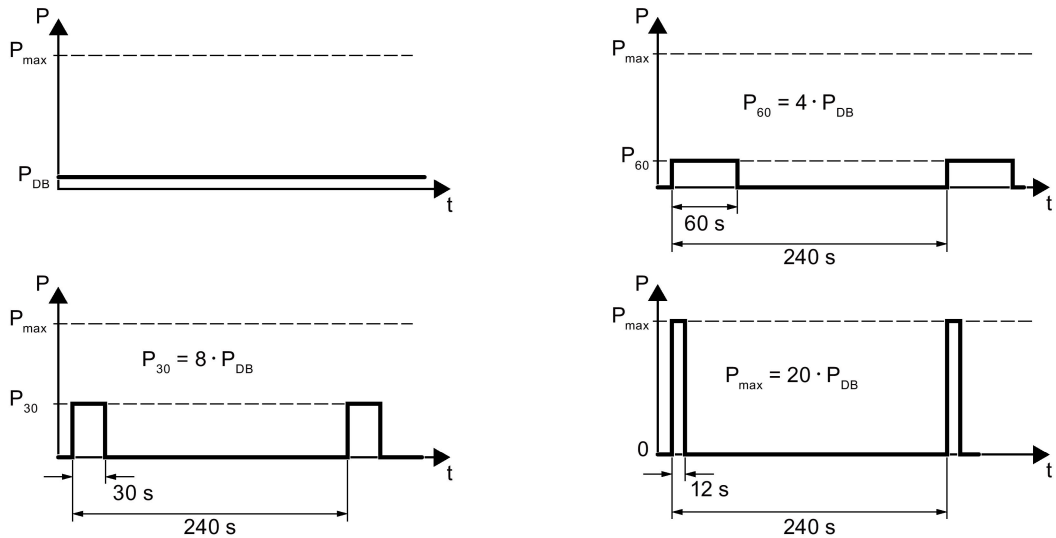

Figure 8-7 Pulse power, rated power and examples of the switch-on duration of the braking resistor

8.7 Connecting a motor holding brake

The inverter uses the Brake Relay to control the motor holding brake. Two types of Brake Relay exist:

- The Brake Relay controls the motor holding brake
- The Safe Brake Relay controls a 24 V motor holding brake and monitors the brake control for short-circuit or cable breakage.

Note

Brake Relay and Safe Brake Relay

The Brake Relay and the Safe Brake Relay do not differ from each other in the installation and the connection to the inverter.

Connection to the inverter

To ensure that you have the correct cable for connecting the Brake Relay irrespective of the inverter size, you are supplied with two preassembled cables with different lengths. Connect the appropriate cable to the Brake Module and to the inverter as shown below.

If you are using your own cable, ensure that the cable is insulated and rated for 600 V.

Connecting the motor holding brake via a PELV circuit

The Brake Relay must be connected to the protective conductor if the motor brake is supplied from a PELV circuit.

8.7.1 Technical data of the brake relay?

| | Brake Relay 6SL3252-0BB00-0AA0 | Safe Brake Relay 6SL3252-0BB01-0AA0 |
|--|--|--|
| Input voltage | via the Power Module | 20.4 ... 28.8 VDC ¹⁾ |
| Input current | via the Power Module | Max. 2.5 A |
| Max. connection cross-section: | 2.5 mm ² | 2.5 mm ² |
| Degree of protection | IP20 | IP20 |
| Switching capability of the NO contact | 1-phase 440 VAC, 3.5 A 1-phase 30 VDC, 12 A | - |
| Output voltage | - | 24 V |
| Output current | - | max. 2 A |

¹⁾ External, controlled power supply required. Recommended voltage: 26 VDC

8.7.2 Connections and circuit diagrams

Brake Relay

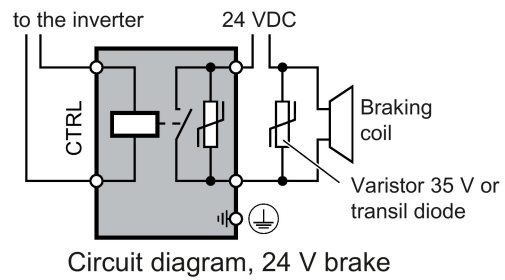
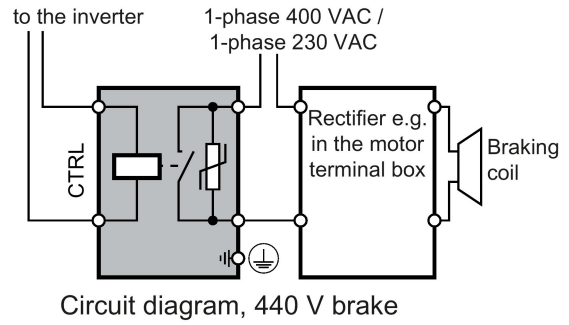
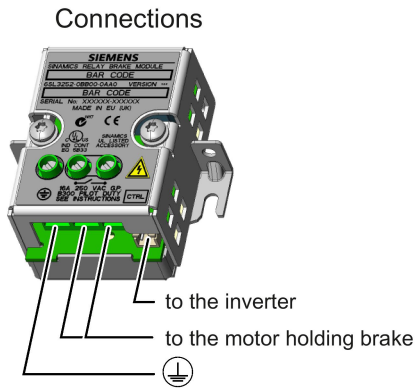

Safe Brake Relay

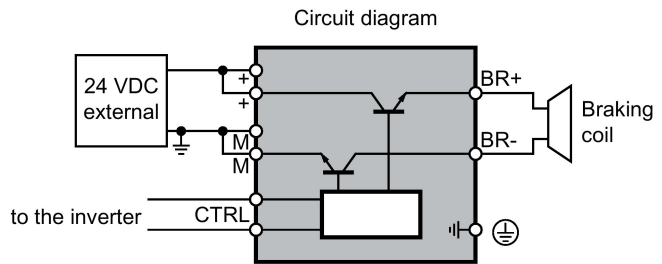
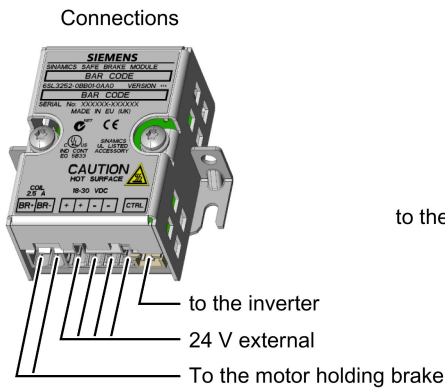

8.7.3 Mounting and connecting the brake relay

Installing the Brake Relay

- **FSA ... FSC:** Install the Brake Relay next to the Power Module.
- **FSD ... FSG:** Install the Brake Relay at the rear of the lower shield plate. Attach the Brake Relay before you install the shield plate.

 Mounting the shield plates (Page 40)

Connecting the Brake Relay to the inverter

The connector for the Brake Relay is located at the front of the Power Module. Lay the cable harness for the Brake Relay in the cable routing.

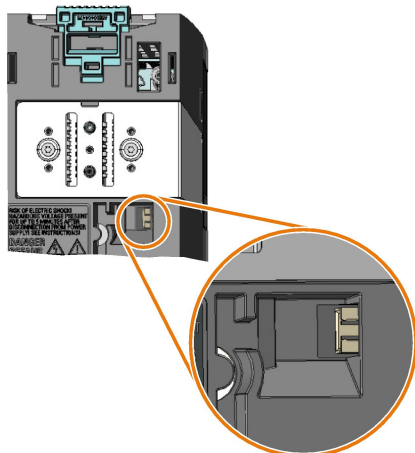

Brake relay connector for FSA ... FSC Power Modules without STO terminals

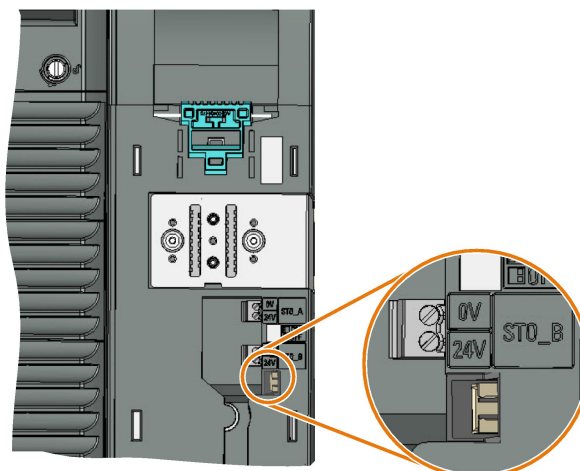

Brake relay connector for FSD ... FSF Power Modules with STO terminals

8.8 Output reactor

Output reactors reduce the voltage stress on the motor windings and the load placed on the inverter as a result of capacitive recharging currents in the cables.

When using the output reactor it is not permissible that the output frequency exceeds 150 Hz. It is not permissible that the pulse frequency exceeds 4 kHz

Mounting position

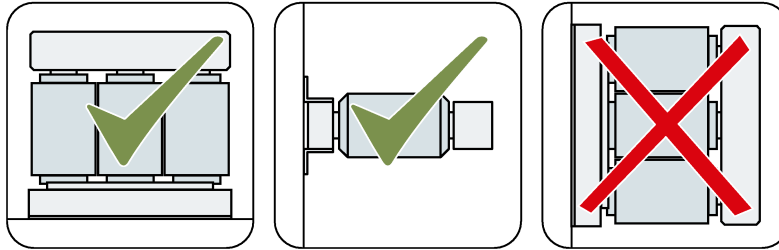

Clearances to other devices

Keep shaded areas free of any devices and components.

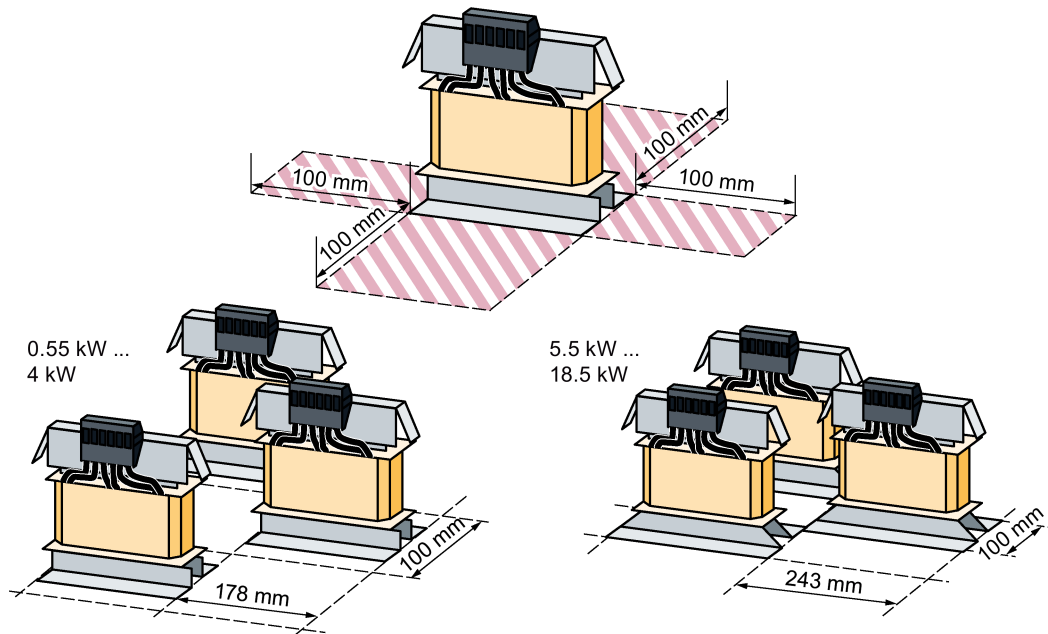

Minimum clearances of the output reactor to other devices, space-saving mounting examples

Dimensions, drilling patterns and weights for FSA ... FSC inverters

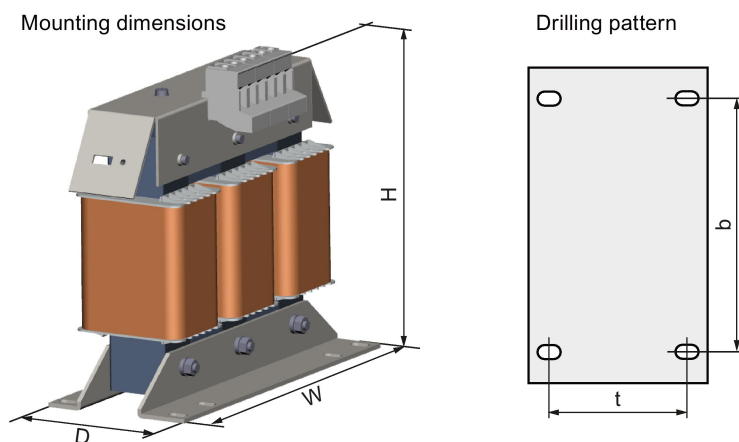

Table 8- 9 Dimensions and weights

| Article number | In-ductance [mH] | Overall dimensions [mm] | | | Drilling dimensions [mm] | | Fixing/torque [Nm] | Weight [kg] |
|--------------------|------------------|-------------------------|-----|-----|--------------------------|----|--------------------|-------------|
| | | W | H | D | b | t | | |
| 6SL3202-0AE16-1CA0 | 2.5 | 207 | 166 | 73 | 166 | 57 | 4 x M4 / 3 | 3.4 |
| 6SL3202-0AE18-8CA0 | 1.3 | 207 | 166 | 73 | 166 | 57 | 4 x M4 / 3 | 3.9 |
| 6SL3202-0AE21-8CA0 | 0.54 | 247 | 211 | 100 | 225 | 81 | 4 x M5 / 6 | 10.1 |
| 6SL3202-0AE23-8CA0 | 0.26 | 257 | 228 | 115 | 225 | 85 | 4 x M5 / 6 | 11.2 |

Output reactors are designed to IP20 degree of protection.

Table 8- 10 Connections to the Power Module and to the motor

| Article number | Connection | |
|--|---|-------------------------|
| | Motor Module and motor | PE |
| 6SL3202-0AE16-1CA0 6SL3202-0AE18-8CA0 | Screw terminals 4 mm ² ; 0.6 ... 0.8 Nm | Threaded bolt M4 / 3 Nm |
| 6SL3202-0AE21-8CA0 | Screw terminals 10 mm ² ; 1.5 ... 1.8 Nm | Threaded bolt M5 / 5 Nm |
| 6SL3202-0AE23-8CA0 | Screw terminals 16 mm ² ; 2 ... 4 Nm | Threaded bolt M5 / 5 Nm |

Dimensions, drilling patterns and weights for FSD ... FSF inverters

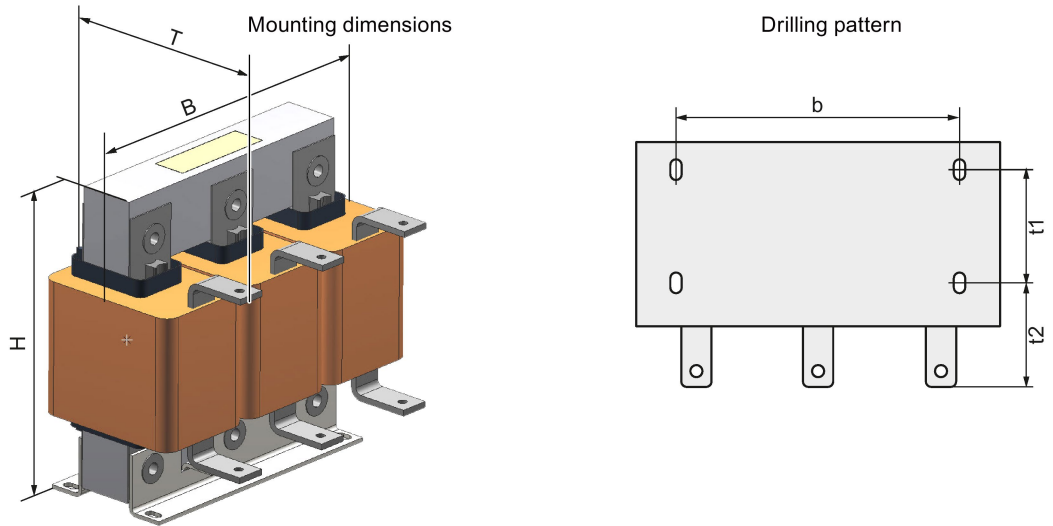

Figure 8-8 Dimensions and drilling patterns

Table 8- 11 Dimensions and weights

| Article number | Overall dimensions [mm] | | | Drilling dimensions [mm] | | | Fixing/torque [Nm] | Weight [kg] |
|--------------------|-------------------------|-----|-----|--------------------------|-----|------|--------------------|-------------|
| | W | H | D | b | t1 | t2 | | |
| 6SE6400-3TC07-5ED0 | 270 | 248 | 209 | 200 | 102 | 91.5 | 4 x M8 / 25 | 26.5 |
| 6SE6400-3TC14-5FD0 | 350 | 321 | 288 | 264 | 140 | 134 | 4 x M8 / 25 | 57 |
| 6SL3000-2BE32-1AA0 | 300 | 285 | 257 | 224 | 165 | 78 | 4 x M8 / 25 | 60 |
| 6SL3000-2BE32-6AA0 | 300 | 315 | 277 | 224 | 185 | 78 | 4 x M8 / 25 | 66 |
| 6SL3000-2AH31-0AA0 | 270 | 248 | 200 | 200 | 103 | 82 | 4 x M8 / 25 | 25 |
| 6SL3000-2AH31-5AA0 | 270 | 248 | 200 | 200 | 103 | 82 | 4 x M8 / 25 | 26 |
| 6SL3000-2BE33-2AA0 | 300 | 285 | 277 | 224 | 183 | 79 | 4 x M8 / 25 | 66 |
| 6SL3000-2BE33-8AA0 | 300 | 285 | 277 | 224 | 183 | 79 | 4 x M8 / 25 | 73 |
| 6SL3000-2BE35-0AA0 | 300 | 365 | 277 | 224 | 183 | 79 | 4 x M8 / 25 | 100 |
| 6SL3000-2AH32-4AA0 | 300 | 285 | 212 | 224 | 118 | 79 | 4 x M8 / 25 | 34 |
| 6SL3000-2AH31-8AA0 | 300 | 285 | 212 | 224 | 118 | 79 | 4 x M8 / 25 | 34 |
| 6SL3000-2AH32-6AA0 | 300 | 285 | 212 | 224 | 118 | 79 | 4 x M8 / 25 | 40 |

The output reactors have a protection rating of IP00.

Table 8- 12 Connections to the Power Module and to the motor

| Article number | Connection | |
|--|------------------------|------------------|
| | Motor Module and motor | PE |
| 6SE6400-3TC07-5ED0 | Cable lug M6 / 6 Nm | Screw M6 / 10 Nm |
| 6SE6400-3TC14-5FD0 | Cable lug M8 / 13 Nm | Screw M8 / 25 Nm |
| 6SL3000-2BE32-1AA0 6SL3000-2BE32-6AA0 | Cable lug M10 / 25 Nm | Screw M8 / 25 Nm |
| 6SL3000-2AH31-0AA0 6SL3000-2AH31-5AA0 | Cable lug M10 / 25 Nm | Screw M6 / 10 Nm |
| 6SL3000-2BE33-2AA0 | Cable lug M10 / 25 Nm | Screw M8 / 25 Nm |
| 6SL3000-2BE33-8AA0 | Cable lug M10 / 50 Nm | Screw M8 / 25 Nm |
| 6SL3000-2BE35-0AA0 | Cable lug M12 / 50 Nm | Screw M8 / 25 Nm |
| 6SL3000-2AH32-4AA0 | Cable lug M10 / 25 Nm | Screw M6 / 10 Nm |
| 6SL3000-2AH31-8AA0 | Cable lug M10 / 25 Nm | Screw M6 / 10 Nm |
| 6SL3000-2AH32-6AA0 | Cable lug M10 / 25 Nm | Screw M6 / 10 Nm |

Table 8- 13 Assignment table for 200 V Power Modules

| Power Module | | | Output reactor |
|--------------|------------------------|------------|--------------------|
| Frame size | Article number | Power [kW] | Article number |
| FSA | 6SL3210-1PB13-0 . L0 | 0.55 | 6SL3202-0AE16-1CA0 |
| FSA | 6SL321 . -1PB13-8 . L0 | 0.75 | |
| FSB | 6SL3210-1PB15-5 . L0 | 1.1 | |
| FSB | 6SL3210-1PB17-4 . L0 | 1.5 | 6SL3202-0AE18-8CA0 |
| FSB | 6SL321 . -1PB21-0 . L0 | 2.2 | 6SL3202-0AE21-8CA0 |
| FSC | 6SL3210-1PB21-4 . L0 | 3 | |
| FSC | 6SL321 . -1PB21-8 . L0 | 4 | |
| FSC | 6SL321 . -1PC22-2 . L0 | 5.5 | 6SL3202-0AE23-8CA0 |
| FSC | 6SL3210-1PC22-8 . L0 | 7.5 | |
| FSD | 6SL3210-1PC24-2UL0 | 11 | 6SE6400-3TC07-5ED0 |
| FSD | 6SL3210-1PC25-4UL0 | 15 | |
| FSD | 6SL321 . -1PC26-8UL0 | 18.5 | |
| FSE | 6SL3210-1PC28-0UL0 | 22 | 6SE6400-3TC14-5FD0 |
| FSE | 6SL321 . -1PC31-1UL0 | 30 | |
| FSF | 6SL3210-1PC31-3UL0 | 37 | |
| FSF | 6SL3210-1PC31-6UL0 | 45 | |
| FSF | 6SL321 . -1PC31-8UL0 | 55 | |

Output reactors are not required for inverters of frame sizes FSD ... FSF

Table 8- 14 Assignment table for 400 V Power Modules

| Power Module | | | Output reactor |
|--------------|------------------------|------------|--------------------|
| Frame size | Article number | Power [kW] | Article number |
| FSA | 6SL3210-1PE11-8 . L1 | 0.55 | 6SL3202-0AE16-1CA0 |
| FSA | 6SL3210-1PE12-3 . L1 | 0.75 | |
| FSA | 6SL3210-1PE13-2 . L1 | 1.1 | |
| FSA | 6SL3210-1PE14-3 . L1 | 1.5 | |
| FSA | 6SL3210-1PE16-1 . L1 | 2.2 | |
| FSA | 6SL321 . -1PE18-0 . L1 | 3 | 6SL3202-0AE18-8CA0 |
| FSB | 6SL3210-1PE21-1 . L0 | 4 | 6SL3202-0AE21-8CA0 |
| FSB | 6SL3210-1PE21-4 . L0 | 5.5 | |
| FSB | 6SL321 . -1PE21-8 . L0 | 7.5 | |
| FSC | 6SL3210-1PE22-7 . L0 | 11 | 6SL3202-0AE23-8CA0 |
| FSC | 6SL321 . -1PE23-3 . L0 | 15 | |
| FSD | 6SL3210-1PE23-8 . L0 | 18.5 | 6SE6400-3TC07-5ED0 |
| FSD | 6SL3210-1PE24-5 . L0 | 22 | |
| FSD | 6SL3210-1PE26-0 . L0 | 30 | |
| FSD | 6SL321 . -1PE27-5 . L0 | 37 | |
| FSE | 6SL3210-1PE28-8 . L0 | 45 | 6SE6400-3TC14-5FD0 |
| FSE | 6SL321 . -1PE31-1 . L0 | 55 | |
| FSF | 6SL3210-1PE31-5 . L0 | 75 | |
| FSF | 6SL3210-1PE31-8 . L0 | 90 | |
| FSF | 6SL3210-1PE32-1 . L0 | 110 | 6SL3000-2BE32-1AA0 |
| FSF | 6SL321 . -1PE32-5 . L0 | 132 | 6SL3000-2BE32-6AA0 |
| FSG | 6SL3210-1PE33-0 . L0 | 160 | 6SL3000-2BE33-2AA0 |
| FSG | 6SL3210-1PE33-7 . L0 | 200 | 6SL3000-2BE33-8AA0 |
| FSG | 6SL3210-1PE34-8 . L0 | 250 | 6SL3000-2BE35-0AA0 |

Output reactors are not required for inverters of frame sizes FSD ... FSG

Table 8- 15 Assignment table for 690 V Power Modules

| Power Module | | | Output reactor |
|--------------|----------------------|------------|--------------------|
| Frame size | Article number | Power [kW] | Article number |
| FSF | 6SL3210-1PH28-0 . L0 | 75 | 6SL3000-2AH31-0AA0 |
| FSF | 6SL3210-1PH31-0 . L0 | 90 | |
| FSF | 6SL3210-1PH31-2 . L0 | 110 | 6SL3000-2AH31-5AA0 |
| FSF | 6SL3210-1PH31-4 . L0 | 132 | |
| FSG | 6SL3210-1PH31-7CL0 | 160 | 6SL3000-2AH31-8AA0 |
| FSG | 6SL3210-1PH32-1CL0 | 200 | 6SL3000-2AH32-4AA0 |
| FSG | 6SL3210-1PH32-5CL0 | 250 | 6SL3000-2AH32-6AA0 |

Output reactors are not required for 690 V inverters

8.9 du/dt filter plus VPL

A combination of du/dt filter and a voltage peak limiter (VPL) – du/dt filter plus VPL – are available to suppress voltage peaks.

When using the du/dt filter plus VPL, the output frequency must not exceed 150 Hz. It is not permissible that the pulse frequency exceeds 4 kHz



Further details for the functional principle and the application cases are available at: Voltage limiter and du/dt filter

(<https://support.industry.siemens.com/cs/ww/de/view/109742112>)

The assignment of the du/dt filter / VPL combination to the Power Modules is contained in the following tables.

Assignment tables

Table 8- 16 Assignment table for 400 V Power Modules

| Power Module | | | VPL-du/dt |
|--------------|------------------------|------------|-----------------|
| Frame size | Article number | Power [kW] | Article number |
| FSD | 6SL3210-1PE23-8 . L0 | 18.5 | JTA:TEF1203-0HB |
| FSD | 6SL3210-1PE24-5 . L0 | 22 | JTA:TEF1203-0JB |
| FSD | 6SL3210-1PE26-0 . L0 | 30 | |
| FSD | 6SL321 . -1PE27-5 . L0 | 37 | JTA:TEF1203-0KB |
| FSE | 6SL3210-1PE28-8 . L0 | 45 | |
| FSE | 6SL321 . -1PE31-1 . L0 | 55 | JTA:TEF1203-0LB |
| FSF | 6SL3210-1PE31-5 . L0 | 75 | |
| FSF | 6SL3210-1PE31-8 . L0 | 90 | JTA:TEF1203-0MB |
| FSF | 6SL3210-1PE32-1 . L0 | 110 | |
| FSF | 6SL321 . -1PE32-5 . L0 | 132 | |

Table 8- 17 Assignment table for 690 V Power Modules

| Power Module | | | VPL-du/dt |
|--------------|----------------------|------------|-----------------|
| Frame size | Article number | Power [kW] | Article number |
| FSD | 6SL3210-1PH21-4 . L0 | 11 | JTA:TEF1203-0GB |
| FSD | 6SL3210-1PH22-0 . L0 | 15 | |
| FSD | 6SL3210-1PH22-3 . L0 | 18.5 | |
| FSD | 6SL3210-1PH22-7 . L0 | 22 | JTA:TEF1203-0HB |
| FSD | 6SL3210-1PH23-5 . L0 | 30 | |
| FSD | 6SL3210-1PH24-2 . L0 | 37 | |
| FSE | 6SL3210-1PH25-2 . L0 | 45 | JTA:TEF1203-0JB |
| FSE | 6SL3210-1PH26-2 . L0 | 55 | |
| FSF | 6SL3210-1PH28-0 . L0 | 75 | JTA:TEF1203-0KB |
| FSF | 6SL3210-1PH31-0 . L0 | 90 | |
| FSF | 6SL3210-1PH31-2 . L0 | 110 | JTA:TEF1203-0LB |
| FSF | 6SL3210-1PH31-4 . L0 | 132 | |
| FSG | 6SL3210-1PH31-7CLO | 160 | JTA:TEF1203-0MB |
| FSG | 6SL3210-1PH32-1CLO | 200 | |
| FSG | 6SL3210-1PH32-5CLO | 250 | |

Appendix

A.1 Manuals and technical support

A.1.1 Manuals for your inverter



Manuals with additional information that can be downloaded:

- Power Module Installation Manual
(<https://support.industry.siemens.com/cs/ww/en/ps/13224/man>)
Installing Power Modules, reactors and filters. Technical specifications, maintenance (this manual)



- CU230P-2 Compact Operating Instructions
(<https://support.industry.siemens.com/cs/ww/en/view/109477360>)
Commissioning the inverter



- CU240B/E-2 Compact Operating Instructions
(<https://support.industry.siemens.com/cs/ww/en/view/109477361>)
Commissioning the inverter



- CU250S-2 Compact Operating Instructions
(<https://support.industry.siemens.com/cs/ww/en/view/99730303>)
Commissioning the inverter.



- CU230P-2 operating instructions
(<https://support.industry.siemens.com/cs/ww/en/view/109478827>)
Installing, commissioning and maintaining the inverter. Advanced commissioning



- CU240B/E-2 operating instructions
(<https://support.industry.siemens.com/cs/ww/en/view/109478828>)
Installing, commissioning and maintaining the inverter. Advanced commissioning



- CU250S-2 operating instructions (<https://support.industry.siemens.com/cs/ww/en/view/109478829>)
Installing, commissioning and maintaining the inverter. Advanced commissioning

- "Safety Integrated" function manual (<https://support.industry.siemens.com/cs/ww/ene/view/109751320>)
Configuring PROFI-safe. Installing, commissioning and operating fail-safe functions of the frequency converter.

- CU230P-2 List Manual (<https://support.industry.siemens.com/cs/ww/en/view/109477248>)
Parameter list, alarms and faults. Graphic function diagrams

- CU240B/E-2 List Manual (<https://support.industry.siemens.com/cs/ww/en/view/109477251>)
Parameter list, alarms and faults. Graphic function diagrams

- CU250S-2 List Manual (<https://support.industry.siemens.com/cs/ww/en/view/109477253>)
Parameter list, alarms and faults. Graphic function diagrams

- EMC installation guideline (<http://support.automation.siemens.com/WW/view/en/60612658>)
EMC-compliant control cabinet design, equipotential bonding and cable routing

- Accessories manual (<https://support.industry.siemens.com/cs/ww/en/ps/13225/man>)
Installation descriptions for inverter components, e.g. line reactors and line filters. The printed installation descriptions are supplied together with the components.

Finding the most recent edition of a manual

If there are multiple editions of a manual, select the latest edition:

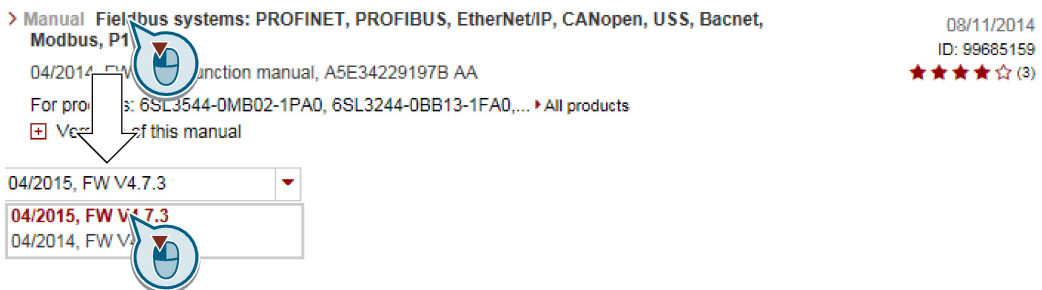





Configuring a manual

Further information about the configurability of manuals is available in the Internet:

 MyDocumentationManager
<https://www.industry.siemens.com/topics/global/en/planning-efficiency/documentation/Pages/default.aspx>.

Select "Display and configure" and add the manual to your "mySupport-documentation":

| | | |
|--|--|---|
| <p>Function manual Function Manual Article number of the documentation: A5E34229197B AA Description / topic 04/2014, FW V4.7,</p> <p> Show and configure  Download (5644 KB)</p> |  | <p>mySupport Cockpit</p> <p></p> <ul style="list-style-type: none"> > Add to mySupport favorites > Add to mySupport documentation > Fav |
|--|--|---|

Not all manuals can be configured.

The configured manual can be exported in RTF, PDF or XML format.

A.1.2 Configuring support

Catalog

Ordering data and technical information for SINAMICS G inverters.



Catalogs for download or online catalog (Industry Mall):

 All about SINAMICS G120 (www.siemens.com/sinamics-g120)

SIZER

The configuration tool for SINAMICS, MICROMASTER and DYNAVERT T drives, motor starters, as well as SINUMERIK, SIMOTION controllers and SIMATIC technology



 SIZER on DVD:

Article number: 6SL3070-0AA00-0AG0

 Download SIZER
<http://support.automation.siemens.com/WW/view/en/10804987/130000>

EMC (electromagnetic compatibility) technical overview

Standards and guidelines, EMC-compliant control cabinet design



EMC overview (<https://support.industry.siemens.com/cs/ww/en/view/103704610>)

EMC Guidelines configuration manual

EMC-compliant control cabinet design, potential equalization and cable routing

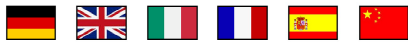

EMC installation guideline
(<http://support.automation.siemens.com/WW/view/en/60612658>)

Safety Integrated for novices technical overview

Application examples for SINAMICS G drives with Safety Integrated



Safety Integrated for novices
(<https://support.industry.siemens.com/cs/ww/en/view/80561520>)

A.1.3 Product Support

You can find additional information about the product on the Internet:



Product support (<https://support.industry.siemens.com/cs/ww/en/>)

This URL provides the following:

- Up-to-date product information (product announcements)
- FAQs
- Downloads
- The Newsletter contains the latest information on the products you use.
- The Knowledge Manager (Intelligent Search) helps you find the documents you need.
- Users and specialists from around the world share their experience and knowledge in the Forum.
- You can find your local representative for Automation & Drives via our contact database under "Contact & Partner".
- Information about local service, repair, spare parts and much more can be found under "Services".

A.2 Disposal

Dispose of the inverter in compliance with the local regulations and statutory provisions.

A.3 Directives and standards

Relevant directives and standards

The following directives and standards are relevant for the inverters:



European Low Voltage Directive

The inverters fulfil the requirements stipulated in Low Voltage Directive 2014/35/EU insofar as they are covered by the scope of application of this Directive.

European Machinery Directive

The inverters fulfil the requirements stipulated in Machinery Directive 2006/42/EU insofar as they are covered by the scope of application of this Directive.

Use of the inverters in a typical machine application has been fully assessed for compliance with the main regulations in this Directive concerning health and safety.

European EMC Directive

By completely complying with IEC/EN 61800-3, it has been proven that the inverter is in compliance with Directive 2004/108/EC or 2014/30/EU.

Underwriters Laboratories (North American market)

Inverters bearing one of the certification marks shown on the left meet the requirements for the North American market as a component of drive applications and are listed correspondingly.



EMC requirements for South Korea

The inverters with the KC marking on the rating plate satisfy the EMC requirements for South Korea.



Eurasian conformity

The inverters comply with the requirements of the Russia/Belarus/Kazakhstan customs union (EAC).



Australia and New Zealand (RCM formerly C-Tick)

The inverters bearing the certification mark shown here meet the EMC requirements for Australia and New Zealand.



A.4 Abbreviations

| Abbreviation | Explanation |
|--------------|---|
| AC | Alternating current |
| CE | Communauté Européenne |
| CU | Control Unit |
| DC | Direct current |
| DI | Digital input |
| DIP switch | DIP switches are small switches, found mostly on PCBs, for making basic device settings |
| DO | Digital output |
| ECD | Equivalent circuit diagram |
| EEC | European Economic Community |
| ELCB | Earth leakage circuit breaker |
| EMC | Electromagnetic compatibility (EMC) |
| EMI | Electromagnetic interference |
| FS... | Frame size ... |
| HO | High overload |
| I/O | Input/Output |
| IGBT | Insulated gate bipolar transistor |
| LED | Light emitting diode |
| LO | Low overload |
| NC | NC contact |
| NEMA | National Electrical Manufacturers Association |
| NO | NO contact |
| OPI | Operating instructions |
| PELV | Protective extra low voltage |
| PM | Power Module |
| PPE | Personnel protective equipment |
| PT | Push-through technology |
| RCCB | Residual-current operated circuit breaker |
| RCD | Residual current device |
| RFI | Radio frequency interference |
| SELV | Safety extra-low voltage |
| VPL | Voltage Peak Limiter; component for limiting voltage peaks |

Index

8

87 Hz characteristic, 70, 70

A

Air barrier, 30

B

Base load, 83

Base load input current, 83

Base load output current, 83

Base load power, 83

Brake Relay, 147

Braking resistor

Clearances, 139

Dimension drawings, 140

Installation, 139

C

Catalog, 159

Category C2, 60

Category C3, 60

Clearances, 139

Commutation dips, 134

Configuring support, 159

Cooling, 30

D

Degree of protection, 21

Delta connection, 70

Derating

Installation altitude, 118

Dimension drawings, 135, 140, 150, 151, 152

Drilling pattern, 135, 140, 151, 152

E

Electrical installation, 47

EMC, 24

F

Field weakening, 70

Function Manual, 157

G

Getting Started, 157

H

Hardware Installation Manual, 157

Harmonic currents, 123

Harmonics, 123, 134

High Overload, 83

Hotline, 160

I

Industry Mall, 159

Installation altitude, 118

Installing, 31

IT system, 50

L

Line reactor

Dimension drawings, 135

Line supply type, 50

List Manual, 157

Low Overload, 83

M

Maintenance

Cleaning, 72

Dirt, 72

Pollution, 72

Terminals, 72

Ventilation, 72

N

Neutral conductor, 50

Number of starting operations, 79

O

Operating instructions, 157

Output reactor

Dimension drawings, 150, 151, 152

Overvoltage protection, 134

P

Power distribution systems, 50

Protective conductor, 50

Q

Questions, 160

S

Safe Brake Relay, 147

Safety notes

Electrical installation, 47

Service life of the fan, 74

SIZER, 159

Standards

EN 61800-3, 162

Star connection (Y), 70

Support, 160

T

Tightening torque, 135

TN system, 50

TT system, 50

Further information

SINAMICS inverters:

www.siemens.com/sinamics

Industry Online Support (Service and Support):

www.siemens.com/online-support

Industry Mall:

www.siemens.com/industrymall

Siemens AG
Digital Factory
Motion Control
Postfach 3180
91050 ERLANGEN
Germany

For further
information about
SINAMICS G120,
scan the QR code.

