

SIEMENS

MICROMASTER 411 & COMBIMASTER 411

Operating Instructions

Issue 07/05

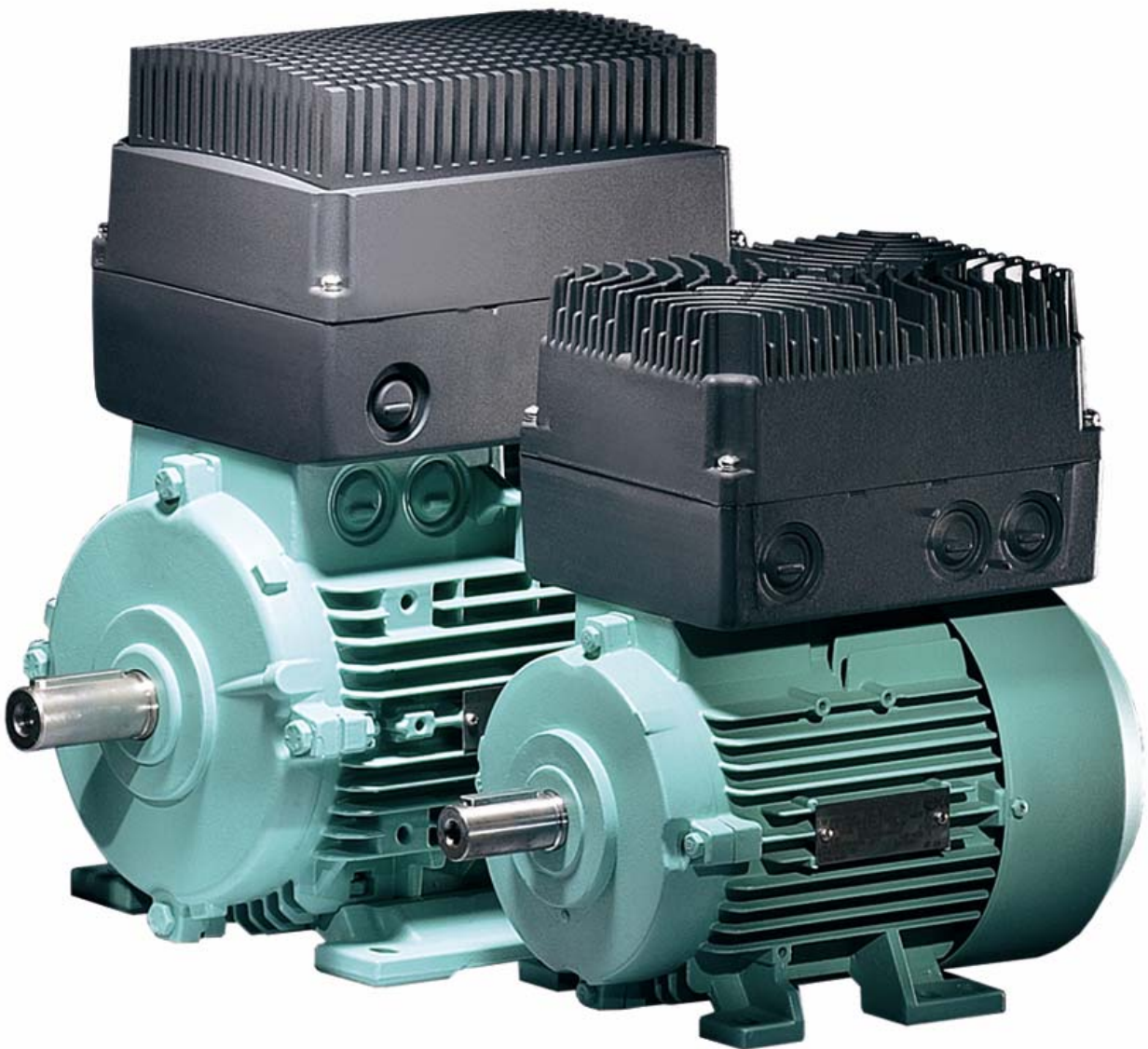

User Documentation
6SE6400-5CA00-0BP0

MICROMASTER 411 / COMBIMASTER 411 Documentation

Getting Started Guide

Provides for Quick Commissioning of the Inverter.



Operating Instructions

Gives information about features of the MICROMASTER 411 / COMBIMASTER 411, Installation, Commissioning, Control modes, System Parameter structure, Troubleshooting, Specifications and available options of the MICROMASTER 411 / COMBIMASTER 411.



Parameter List

The Parameter List contains the description of all Parameters structured in functional order and a detailed description. The Parameter list also includes a series of function plans.



Catalogues

In the catalogue you will find all the necessary information to select an appropriate inverter, as well as Operator Panels and Communication Options.





MICROMASTER 411 & COMBIMASTER 411

Operating Instructions
User Documentation

Valid for Release

Issue 07/05

Inverter Type
MICROMASTER 411 &
COMBIMASTER 411

Control Version
1.1

Issue 07/05

Overview	1
Installation	2
Commissioning	3
Using the COMBIMASTER 411 / MICROMASTER 411	4
System Parameters	5
Troubleshooting	6
Specifications	7
Options	8
Electro-Magnetic Compatibility	9
Engineering Information	10
Appendices	A B C
Index	

IMPORTANT NOTICE

Not all inverters and option modules have UL listing.

UL listing can be determined by examining the Rating Label.

For UL listed products the following UL mark is used:



UL listing refers only to MICROMASTER 411 when used in conjunction with the wall mounting kit (6SE6401-00WM00-0AA0)

Further information is available on the Internet under:
<http://www.siemens.de/micromaster>

Approved Siemens Quality for Software and Training
is to DIN ISO 14001, Reg. No. 2160-01

The reproduction, transmission or use of this document, or its contents is not permitted unless authorized in writing. Offenders will be liable for damages. All rights including rights created by patent grant or registration of a utility model or design are reserved.

© Siemens AG 2002. All Rights Reserved.

MICROMASTER® is a registered trademark of Siemens.

Other functions not described in this document may be available. However, this fact shall not constitute an obligation to supply such functions with a new control, or when servicing.

We have checked that the contents of this document correspond to the hardware and software described. There may be discrepancies nevertheless, and no guarantee can be given that they are completely identical. The information contained in this document is reviewed regularly and any necessary changes will be included in the next edition. We welcome suggestions for improvement.

Siemens handbooks are printed on chlorine-free paper that has been produced from managed sustainable forests. No solvents have been used in the printing or binding process.

Document subject to change without prior notice.

Foreword

User Documentation



WARNING

Before installing and commissioning, you must read the safety instructions and warnings carefully and all the warning labels attached to the equipment. Make sure that the warning labels are kept in a legible condition and replace missing or damaged labels.

Information is also available from:

Regional Contacts

Please get in touch with your contact for Technical Support in your Region for questions about services, prices and conditions of Technical Support.

Central Technical Support

The competent consulting service for technical issues with a broad range of requirements-based services around our products and systems.

Europe / Africa	Tel:	+49 (0) 180 5050 222
	Fax:	+49 (0) 180 5050 223
	Email:	adsupport@siemens.com
America	Tel:	+1 423 262 2522
	Fax:	+1 423 262 2589
	Email:	simatic.hotline@sea.siemens.com
Asia / Pazific	Tel:	+86 1064 757 575
	Fax:	+86 1064 747 474
	Email:	adsupport.asia@siemens.com

Online Service & Support

The comprehensive, generally available information system over the Internet, from product support to service & support to the support tools in the shop.

<http://www.siemens.com/automation/service&support>

Contact address

Should any questions or problems arise while reading this manual, please contact the Siemens office concerned using the form provided at the back this manual.

Definitions and Warnings



DANGER

indicates an imminently hazardous situation which, if not avoided, will result in death or serious injury.



WARNING

indicates a potentially hazardous situation which, if not avoided, could result in death or serious injury.



CAUTION

used with the safety alert symbol indicates a potentially hazardous situation which, if not avoided, may result in minor or moderate injury.

CAUTION

used without safety alert symbol indicates a potentially hazardous situation which, if not avoided, may result in a property damage.

NOTICE

indicates a potential situation which, if not avoided, may result in an undesirable result or state.

NOTE

For the purpose of this documentation, "Note" indicates important information relating to the product or highlights part of the documentation for special attention.

Qualified personnel

For the purpose of this Instruction Manual and product labels, a "Qualified person" is someone who is familiar with the installation, mounting, start-up and operation of the equipment and the hazards involved.

He or she must have the following qualifications:

1. Trained and authorized to energize, de-energize, clear, ground and tag circuits and equipment in accordance with established safety procedures.
 2. Trained in the proper care and use of protective equipment in accordance with established safety procedures.
 3. Trained in rendering first aid.
-

PE
 = Ground

-
- PE – Protective Earth uses circuit protective conductors sized for short circuits where the voltage will not rise in excess of 50 Volts. This connection is normally used to ground the inverter.
 -  - Is the ground connection where the reference voltage can be the same as the Earth voltage. This connection is normally used to ground the motor.
-

Use for intended purpose only

The equipment may be used only for the application stated in the manual and only in conjunction with devices and components recommended and authorized by Siemens.

Safety Instructions

The following Warnings, Cautions and Notes are provided for your safety and as a means of preventing damage to the product or components in the machines connected. This section lists Warnings, Cautions and Notes, which apply generally when handling COMBIMASTER 411 & MICROMASTER 411 Inverters, classified as **General, Transport & Storage, Commissioning, Operation, Repair and Dismantling & Disposal**.

Specific Warnings, Cautions and Notes that apply to particular activities are listed at the beginning of the relevant chapters and are repeated or supplemented at critical points throughout these chapters.

Please read the information carefully, since it is provided for your personal safety and will also help prolong the service life of your COMBIMASTER 411 & MICROMASTER 411 Inverter and the equipment you connect to it.

General



WARNING

- This equipment contains dangerous voltages and controls potentially dangerous rotating mechanical parts. Non-compliance with **Warnings** or failure to follow the instructions contained in this manual can result in loss of life, severe personal injury or serious damage to property.
 - Only suitable qualified personnel should work on this equipment, and only after becoming familiar with all safety notices, installation, operation and maintenance procedures contained in this manual. The successful and safe operation of this equipment is dependent upon its proper handling, installation, operation and maintenance.
 - Risk of electric shock. The DC link capacitors remain charged for five minutes after power has been removed. **It is not permissible to open the equipment until 5 minutes after the power has been removed.**
 - HP ratings are based on the Siemens 1LA motors and are given for guidance only; they do not necessarily comply with UL or NEMA HP ratings.
 - Do not operate the equipment in direct sunlight.
-



CAUTION

- Children and the general public must be prevented from accessing or approaching the equipment!
 - This equipment may only be used for the purpose specified by the manufacturer. Unauthorized modifications and the use of spare parts and accessories that are not sold or recommended by the manufacturer of the equipment can cause fires, electric shocks and injuries.
-

NOTICE

- Keep these operating instructions within easy reach of the equipment and make them available to all users
 - Whenever measuring or testing has to be performed on live equipment, the regulations of Safety Code VBG 4.0 must be observed, in particular § 8 "Permissible Deviations when Working on Live Parts". Suitable electronic tools should be used.
 - Before installing and commissioning, please read these safety instructions and warnings carefully and all the warning labels attached to the equipment. Make sure that the warning labels are kept in a legible condition and replace missing or damaged labels.
-

Transport & Storage

WARNING

- Correct transport, storage, erection and mounting, as well as careful operation and maintenance are essential for proper and safe operation of the equipment.
 - Use the lifting eyes provided if a motor has to be lifted.
 - Do not lift machine sets by suspending the individual machines! Always check the capacity of the hoist before lifting any equipment.
 - Do not paint over the black case finish of the inverter, as this will affect the unit's
-

CAUTION

Protect the inverter against physical shocks and vibration during transport and storage. Also be sure to protect it against water (rainfall) and excessive temperatures (see Table 7-1 on page 106).

Commissioning



WARNING

- Work on the device/system by unqualified personnel or failure to comply with warnings can result in severe personal injury or serious damage to material. Only suitably qualified personnel trained in the setup, installation, commissioning and operation of the product should carry out work on the device/system.
- Only permanently wired input power connections are allowed. This equipment must be grounded (IEC 536 Class 1, NEC and other applicable standards).
- If a Residual Current-operated protective Device (RCD) is to be used, it must be an RCD type B.
- Machines with a three-phase power supply, fitted with EMC filters, must not be connected to a supply via an ELCB (Earth Leakage Circuit-Breaker - see DIN VDE 0160, section 5.5.2 and EN50178 section 5.2.11.1).
- The following terminals can carry dangerous voltages even if the inverter is inoperative:
 - power supply terminals L1, L2, L3
 - motor terminals U, V, W
 - additionally the terminals DC+, DC-
- This equipment must not be used as an 'Emergency Stop mechanism' (see EN 60204, 9.2.5.4).
- The inverter electronics contain static sensitive devices therefore precautions must be taken against electrostatic discharge (ESD) when handling the separated inverter assembly. These include not touching the internal surfaces of the inverter and ensuring that personnel are earthed while handling the unit. The terminal housing, including Filter and I/O modules, contain no sensitive components and therefore no special handling precautions are required when separated.



CAUTION

The connection of power, motor and control cables to the inverter must be carried out as shown in Figure 2-13 respectively, to prevent inductive and capacitive interference from affecting the correct functioning of the inverter.

Operation



WARNING

- MICROMASTER 411/COMBIMASTER 411 operate at high voltages.
- When operating electrical devices, it is impossible to avoid applying hazardous voltages to certain parts of the equipment.
- Emergency Stop facilities according to EN 60204 IEC 204 (VDE 0113) must remain operative in all operating modes of the control equipment. Any disengagement of the Emergency Stop facility must not lead to uncontrolled or undefined restart.
- Wherever faults occurring in the control equipment can lead to substantial material damage or even grievous bodily injury (i.e. potentially dangerous faults), additional external precautions must be taken or facilities provided to ensure or enforce safe operation, even when a fault occurs (e.g. independent limit switches, mechanical interlocks, etc.).
- Certain parameter settings may cause the inverter to restart automatically after an input power failure.
- Motor parameters must be accurately configured for motor overload protection to operate correctly.
- This equipment is capable of providing internal motor overload protection in accordance with UL508C. Refer to P0610 (level 3) and P0335. i^2t is ON by default. Motor overload protection can also be provided using an external PTC via a digital input.
- This equipment is suitable for use in a circuit capable of delivering not more than 10,000 symmetrical amperes (rms), for a maximum voltage of 460 V when protected by an H, J or K type fuse, a circuit breaker or self-protected combination motor controller.
- This equipment must not be used as an 'emergency stop mechanism' (see EN 60204, 9.2.5.4)

Repair



WARNING

- Repairs on equipment may only be carried out by **Siemens Service**, by repair centers **authorized by Siemens** or by qualified personnel who are thoroughly acquainted with all the warnings and operating procedures contained in this manual.
- Any defective parts or components must be replaced using parts contained in the relevant spare parts list.
- Disconnect the power supply before opening the equipment for access.

Dismantling & Disposal

NOTE

- Inverter packaging is re-usable. Retain the packaging for future use or return it to the manufacturer.
 - Easy-to-release screw and snap connectors allow you to break the unit down into its component parts. You can then re-cycle these component parts, dispose of them in **accordance with local requirements or return them to the manufacturer.**
-

Table of Contents

Foreword	5
Definitions and Warnings	6
Safety Instructions	8
Table of Contents	13
1 Overview	19
1.1 MICROMASTER 411 / COMBIMASTER 411	20
1.2 Design Features.....	21
2 Installation.....	23
2.1 Installation after a Period of Storage	25
2.2 Ambient operating conditions	26
2.3 Mechanical Installation MICROMASTER 411	27
2.4 Mechanical Installation COMBIMASTER 411	35
2.5 Electrical Installation	40
3 Commissioning	47
3.1 Block Diagram.....	49
3.2 General Information	50
3.3 Commissioning Procedure Overview.....	51
3.4 General operation	63
4 Using the MICROMASTER 411 / COMBIMASTER 411.....	67
4.1 Frequency Setpoint (P1000).....	68
4.2 Command Sources (P0700)	69
4.3 OFF and Braking Functions.....	70
4.4 Control Modes (P1300).....	72
4.5 Faults and warnings.....	73
5 System Parameters	75
5.1 Introduction to System Parameters	76
5.2 Parameter Structure.....	77
5.3 Parameter List (short form).....	78
6 Troubleshooting	89
6.1 Troubleshooting with the Inverter LED	90
6.2 Troubleshooting with the Basic Operator Panel	90
6.3 Faults and Alarms.....	91

7	Specifications	103
7.1	General Data.....	104
7.2	Case Size Rating Information	105
7.3	Tightening Torque, Cable cross sections for Power Supply and Motor Terminals.....	106
7.4	Tightening Torque for Fixing Screws	106
7.5	Fuses and Circuit Breakers	107
8	Options.....	109
8.1	Options – Overview.....	110
8.2	Programming Options	111
8.3	Communication modules	117
8.4	Brake function modules	120
8.5	Wall mounting kit.....	122
9	Electro-Magnetic Compatibility (EMC).....	123
9.1	Electro-Magnetic Compatibility (EMC).....	124
9.2	EMC Directive Compliance with Harmonics Regulations	125
10	Engineering Information.....	129
10.1	Current Limit and Overload Operation.....	131
10.2	Control and Operating Modes.....	136
10.3	Braking.....	149
10.4	Derating Factors	152
10.5	Thermal Protection and Automatic De-rating	155
10.6	Operation from Unearthed Supplies	155
10.7	Lifetime of Inverters	155
10.8	Working with Binary Connectors (BiCo)	156
10.9	Harmonic Currents.....	164
10.10	Use of MICROMASTER 4 Input Chokes	164
10.11	Power Losses	165
10.12	Shock and Vibration.....	166
10.13	PROFIBUS.....	167
10.14	Variant Independent Options	172
	Appendices	175
A.1	Applicable Standards.....	175
A.2	List of Abbreviations.....	176
A.3	MICROMASTER 411 / COMBIMASTER 411 Parts Identification	178
A.4	Index	179

List of Tables

Table 2-1	MICROMASTER 411 Dimension Detail	31
Table 2-2	Gland Plate Detail	33
Table 2-3	COMBIMASTER 411– Construction Type IM B 3 – Case Size B	36
Table 2-4	COMBIMASTER 411– Construction Type IM B 3 – Case Size C	37
Table 2-5	COMBIMASTER 411– Construction Type IM B 5 – Case Size B	38
Table 2-6	COMBIMASTER 411– Construction Type IM B 5 – Case Size C	39
Table 3-1	Control Circuit Jumper Settings	53
Table 3-2	Inverter behaviour when fitting or removing Control Circuit Jumpers	53
Table 3-3	Ramp Time Adjustment Jumpers	54
Table 3-4	Ramp Time Jumper Behaviour	55
Table 3-5	Default Settings for BOP Operation	57
Table 6-1	Inverter LED Indication	90
Table 7-1	MICROMASTER 411 / COMBIMASTER 411, General Data	104
Table 7-2	Case Size B	105
Table 7-3	Case Size C	105
Table 7-4	Power Supply & Motor Terminal Wire Sizes/Tightening Torques	106
Table 7-5	Fixing Screw Recommended Tightening Torque	106
Table 7-6	MICROMASTER 411/COMBIMASTER 411 Fuses and Circuit Breakers	107
Table 8-1	Key to Programming Options	111
Table 9-1	Environment - General Industrial	125
Table 9-2	Class 2 - Filtered Industrial	126
Table 9-3	Class 3 - Filtered for Residential. Commercial and Light Industry	127
Table 9-4	EMC Compliance Table	128
Table 9-5	MICROMASTER 411 Measured Results	128
Table 10-1	Measured Current Monitoring Accuracy	132
Table 10-2	Trip Levels	135
Table 10-3	Derating with Switching Frequencies	154
Table 10-4	Use of BiCo parameterization to enable the output relay using Digital Input 2	157
Table 10-5	Select an alternative ramp up time (JOG)	158
Table 10-6	BiCo Connections (r0019 to r0054)	160
Table 10-7	BiCo Connections (r0055 to r1119)	161
Table 10-8	BiCo Connections (r1170 to r2050)	162
Table 10-9	BiCo Connections (r2053 to r2294)	163

Table 10-10	Three Phase 400 V Connection	164
Table 10-11	Maximum Cable Lengths for Data Transfer Rates	170
Table 10-12	Technical data – 411 PROFIBUS Module	171
Table 10-13	PROFIBUS Ordering information	171

List of Illustrations

Figure 1-1	MICROMASTER 411 und COMBIMASTER 411 Frequency Inverter	22
Figure 2-1	Forming.....	25
Figure 2-2	MICROMASTER 411, Internal Layout.....	30
Figure 2-3	MICROMASTER 411 Case Size B Dimensions	31
Figure 2-4	MICROMASTER 411 Case Size C Dimensions.....	31
Figure 2-5	Cable Glands	32
Figure 2-6	Installation of Cable Gland	32
Figure 2-7	MICROMASTER 411 Gland Dimensions	33
Figure 2-8	Mounting the Inverter on a 1LA7 and 1LA9 Siemens Motor	34
Figure 2-9	COMBIMASTER 411– Construction Type IM B 3 – Case Size B	36
Figure 2-10	COMBIMASTER 411– Construction Type IM B 3 – Case Size C	37
Figure 2-11	COMBIMASTER 411– Construction Type IM B 5 – Case Size B	38
Figure 2-12	COMBIMASTER 411– Construction Type IM B 5 – Case Size C	39
Figure 2-13	Motor and Power Supply Connections	43
Figure 2-14	Control Terminals	44
Figure 2-15	PTC Connections.....	45
Figure 3-1	COMBIMASTER 411 & MICROMASTER 411 Block Diagram.....	49
Figure 3-2	MICROMASTER 411 / COMBIMASTER 411 Commissioning Guide	51
Figure 3-3	Control Circuit Jumpers	52
Figure 3-4	Ramp Time Jumpers	54
Figure 3-5	Basic Operator Panel Controls	58
Figure 3-6	Changing parameters via the BOP	59
Figure 3-7	Typical Motor Rating Plate Example	62
Figure 3-8	Default Setup Terminal Connections.....	63
Figure 3-9	Connect BOP/AOP with the MICROMASTER 411	65
Figure 5-1	Parameter Structure with Filter (P0004)	77
Figure 8-1	Connection BOP or AOP with Operator Panel Mounting Kit or Operator Panel Door Mounting Kit.....	112
Figure 8-2	Operator Panel Mounting Kit	113
Figure 8-3	Operator Panel Door Mounting Kit for Single Inverter	114
Figure 8-4	Programming via PC, isolated	115
Figure 8-5	PC-AOP Connection Kit.....	116
Figure 8-6	PROFIBUS Module.....	117
Figure 8-7	AS-Interface Module	118
Figure 8-8	DeviceNet Module	119

Figure 8-9	REM Module	120
Figure 8-10	EM Module.....	121
Figure 8-11	Wall mounting kit for MICROMASTER 411	122
Figure 10-1	Current Limit Interaction	132
Figure 10-2	PTC Resistor Connections	134
Figure 10-3	Boost Level	136
Figure 10-4	Quick response with overshoot: P2280 = 0.30; P2285 = 0.03 s	140
Figure 10-5	Quick response with overshoot, but instability:P2280 = 0.55; P2285 = 0.03 s	141
Figure 10-6	Damped response: P2280 = 0.20; P2285 = 0.15 s	141
Figure 10-7	Response to 5 Hz step: L = 100 ms	143
Figure 10-8	Response to 5 Hz step: T = 700 ms	143
Figure 10-9	Step Response in PI control with P2280 = 9.84 and P2285 = 0.30	144
Figure 10-10	PI Basic Block Diagram	145
Figure 10-11	Energy Saving Mode 1	146
Figure 10-12	Energy Saving Mode 2	147
Figure 10-13	Frequency Ramp Down.....	149
Figure 10-14	DC Braking	150
Figure 10-15	COMPOUND- Braking.....	151
Figure 10-16	Derating with Temperature	152
Figure 10-17	Derating with Altitude.....	153
Figure 10-18	Power Losses MICROMASTER 411 / COMBIMASTER 411	165

1 Overview

This Chapter contains:

A summary of the major features of the COMBIMASTER 411 & MICROMASTER 411 range.

1.1	MICROMASTER 411 / COMBIMASTER 411	20
1.2	Design Features.....	21

1.1 MICROMASTER 411 / COMBIMASTER 411

The Siemens COMBIMASTER 411 & MICROMASTER 411 variable frequency (V/f) range of inverters are used to control the speed of three phase AC induction motors.

COMBIMASTER 411 provides for a ready to use Inverter/Motor combination unit

MICROMASTER 411 offers an Inverter for adaptation to a compatible motor with terminal boxes of size GK030.

Inverters are available in ranges 370 W to 3.0 kW 380/480 V AC for three phase units.

The inverters are microprocessor-controlled and use state-of-the-art Insulated Gate Bipolar Transistor (IGBT) technology. This makes them reliable and versatile. A special pulse-width modulation method with selectable Pulse frequency permits quiet motor operation. Comprehensive protective functions provide excellent inverter and motor protection.

With the factory default settings, the MICROMASTER 411 / COMBIMASTER 411 is suitable for many variable speed applications. Using the functionally grouped parameters, the MICROMASTER 411 / COMBIMASTER 411 can be adapted to more demanding applications.

MICROMASTER 411/COMBIMASTER 411 can be used in 'stand-alone' applications as well as being integrated into complete automation systems.

1.2 Design Features

Main Characteristics

- Easy installation
- Easy commissioning
- High starting torque with programmable starting boost
- Options for remote control:
 - Basic Operator Panel
 - Advanced Operator Panel
 - Serial interface (RS232)
- Factory default parameter settings pre-programmed for European and North American requirements
- Output frequency (and hence motor speed) can be controlled by one of four methods:
 - Internal Speed Control Potentiometer
 - Analogue setpoint (voltage or current input)
 - Fixed frequencies via binary inputs
 - Serial interface
- Programmable signal relay output incorporated
- Rugged EMC design
- Fast repeatable response time to control signals
- Comprehensive range of parameters enabling configuration for a wide range of applications
- Simple connection
- High switching frequencies for low-noise motor operation
- Detailed status information and integrated messaging functions
- External options for PC communications, Basic Operator Panel (BOP), Advanced Operator Panel (AOP), PROFIBUS communications module
- Option for integrated class B-filter (interference emission class A)
- Optional housing for installing PROFIBUS module and EM control module

Performance Characteristics

- Flux Current Control (FCC) for improved dynamic response and motor control
- Fast Current Limitation (FCL) for trip-free operation
- Built-in DC injection brake
- Compound braking to improve braking performance
- Ramp function generator with programmable smoothing
- Control with Proportional-Integral control function (PI)
- Multi-point V/f characteristic

Protection characteristics

- MICROMASTER 411: Type of protection up to IP66 (NEMA 3 ONLY)
- COMBIMASTER 411: Type of protection up to IP55
- Overvoltage/undervoltage protection
- Overtemperature protection for the inverter
- Short-circuit protection
- i^2t thermal motor protection
- PTC for motor protection, via digital input 3
- Stall prevention
- Parameter lock

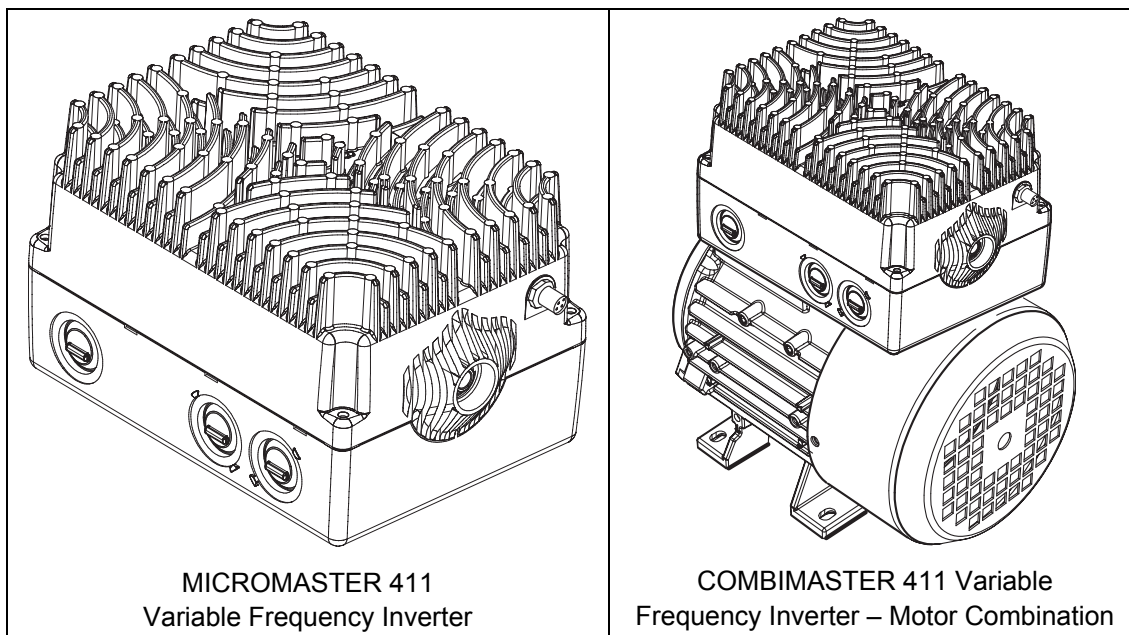

Figure 1-1 MICROMASTER 411 und COMBIMASTER 411 Frequency Inverter

2 Installation

This Chapter contains:

- General data relating to installation
- Inverter Dimensions
- Wiring guidelines to minimize the effects of EMI
- Details concerning electrical installation

2.1	Installation after a Period of Storage	25
2.2	Ambient operating conditions	26
2.3	Mechanical Installation MICROMASTER 411	27
2.3.1	Preparation	27
2.3.2	Installation Procedure	28
2.3.3	Layout of MICROMASTER 411	30
2.3.4	Installation of Cable Glands.....	32
2.3.5	Mounting the Inverter on a 1LA7 and 1LA9 Siemens Motor	34
2.3.6	Wall Mounting the Inverter.....	34
2.4	Mechanical Installation COMBIMASTER 411	35
2.4.1	COMBIMASTER 411 Installation Procedure	35
2.4.2	COMBIMASTER 411 Construction Type IM B 3	36
2.4.3	COMBIMASTER 411 Construction Type IM B 5	38
2.5	Electrical Installation	40
2.5.1	General	40
2.5.2	Line and Motor Connections.....	41
2.5.3	Control Cable Connections.....	44
2.5.4	Motor PTC Connections	45
2.5.5	Avoiding Electro-Magnetic Interference.....	46



WARNING

- Work on the device/system by **unqualified** personnel or failure to comply with warnings can result in severe personal injury or serious damage to material. Only suitably qualified personnel trained in the setup, installation, commissioning and operation of the product should carry out work on the device/system.
- Only permanently wired input power connections are allowed. This equipment must be grounded (IEC 536 Class 1, NEC and other applicable standards).
- If a Residual Current-operated protective Device (RCD) is to be used, it must be an RCD type B.
- Machines with a three-phase power supply, fitted with EMC filters, must not be connected to a supply via an ELCB (Earth Leakage Circuit-Breaker EN50178 Section 5.2.11.1).
- The following terminals can carry dangerous voltages even if the inverter is inoperative:
 - power supply terminals L1, L2, L3
 - motor terminals U, V, W
 - additionally the terminals DC+, DC-
- Always wait **5 minutes** to allow the unit to discharge after switching off before carrying out any installation work.
- This equipment must not be used as an 'emergency stop mechanism' (see *EN 60204, 9.2.5.4*)
- The minimum size of the earth-bonding conductor must be equal to or greater than the cross-section of the power supply cables.
- MICROMASTER 411/COMBIMASTER 411 is not suitable for connection to rigid conduit systems. Use flexible cables (CY and SY types) for motor output and flexible cables or flexible conduit for mains input or control connections.

CAUTION

The connection of power and motor cables to the inverter must be carried out as shown in Figure 2-13 to prevent inductive and capacitive interference from affecting the correct functioning of the inverter.

2.1 Installation after a Period of Storage

Following a prolonged period of storage, you must reform the capacitors in the inverter. **It is important that the time of storage is calculated from the time of manufacture and not the time of delivery.** The requirements are listed below.

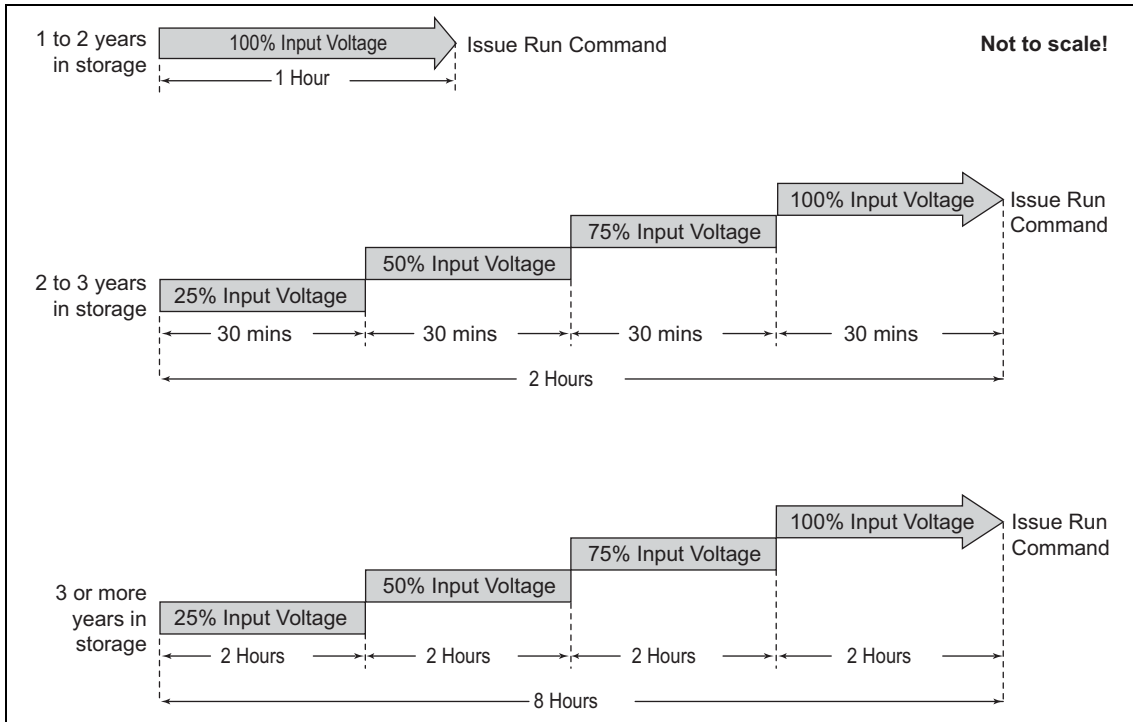

Figure 2-1 Forming

2.2 Ambient operating conditions

Temperature

Operating temperature -10 °C to $+40\text{ °C}$
(power reduction at $+50\text{ °C}$ see Section 10.4.1).

Humidity Range

$\leq 99\%$, Non-condensing

Altitude

If the inverter is to be installed at an altitude $> 1000\text{ m}$, derating will be required.
Refer to Section 10.12 for details.

Shock

Refer to the notes in Section 10.12.

Electromagnetic Radiation

Do not install the inverter near sources of electromagnetic radiation.

Overheating

MICROMASTER 411 / COMBIMASTER 411 are cooled by natural convection.
Mount the inverter with the heatsink fins above to ensure optimum cooling.

Mounting the inverter with the heatsink upside down is not allowed.

Ensure that airflow around the inverter housing is not obstructed. Allow 100 mm clearance above and below the inverter.

2.3 Mechanical Installation MICROMASTER 411



WARNING

- **This equipment must be grounded.**
 - To ensure safe operation of the equipment, it must be installed and commissioned by qualified personnel in full compliance with the warnings laid down in these operating instructions.
 - Take particular note of the general and regional installation and safety regulations regarding work on dangerous voltage installations (e.g. EN 50178), as well as the relevant regulations regarding the correct use of tools and personal protective gear.
 - The Power supply, DC and motor terminals, can carry dangerous voltages even if the inverter is inoperative; wait **5 minutes** to allow the unit to discharge after switching off before carrying out any installation work.
-

2.3.1 Preparation

Remove the MICROMASTER 411 installation kit from the packing. Check packing box contents against the advice note supplied.

The installation kit should comprise the following items:

1. Inverter cover
2. Terminal Housing
3. Filter Module & screws (captive)
4. Input – Output Board & screws (captive)
5. Earth Lead
6. 10 Off Terminal Jumpers
7. Getting Started Guide and CD
8. 2 off Glands M25 IP68 with O-ring
9. 2 off M25 sealing plugs
10. 2 off M25 Gland Fixing Plates
11. 2 off U-clamp & screws (for earth/ground connection)
12. 4 off M4 Inverter to Motor fixing screws
(CSC only: additional 4 off M5 screws)
13. Motor Cable Sheath
14. 1 off Motor Gasket (CSC only: additional 1 off Motor Gasket)
15. 1 off M12 connector blanking plug

Any defective or missing items should be reported immediately to your local Siemens Distributor or Sales Office.

2.3.2 Installation Procedure

NOTE (MICROMASTER 411 ONLY):

Prior to installation it may be necessary to fit an Adaptation Plate to a non-Siemens motor. The Adaptation Plate is prepared by the respective motor manufacturer. Normally the Adaptation Plate makes use of the existing motor gasket

Physical dimensions and characteristics for installation are given in Section:

- 2.3.3 for MICROMASTER 411
- 2.4.1 for COMBIMASTER 411

With the product items removed from their packaging carry out the following installation procedure.

1. Separate the two halves (Inverter Cover and Terminal Housing).
 2. Remove the Filter Module and I/O board.
-

CAUTION

Do not knock out cable gland blanking plates unless the inverter 'electronics' (Filter & I/O boards) have been removed.

3. Remove the cable gland blanking plates (knockouts) as required (see Figure 2-6). The preferred gland arrangements are shown in the General Layout Diagram(see Figure 2-5).
4. Fit cable glands to terminal housing, ensuring the O-rings are fitted to ensure the seal is maintained.
5. Fit the earth lead to the earth terminal within the motor terminal box. If required fit a Motor PTC cable (not supplied).
6. Run all cables between the motor and inverter within the cable sheath provided.
7. Using the appropriate motor gasket, fix the terminal housing to the motor. Screw fixing torque values are: 1.5 Nm – M4 and 2.5 Nm – M5.
8. Insert power and control cables through glands and make off ends as required.
9. Fit the Filter board (see Figure 2-2).
10. Secure Filter board with M3 taptite screws (torque values see Table 7-5).
11. Connect power cables as detailed in Section 2.5.2.
12. Connect up the motor terminals in either star or delta configuration as explained in Section 2.5.2.
13. Connect control wires as detailed in Section 2.5.3.
14. Fit the I/O board (see Figure 2-2).
15. Secure I/O board with M3 taptite screws. (torque values see Table 7-4).
16. Fit jumpers as required – see Section 3.3.
17. Place the inverter cover onto the assembled terminal housing.

18. Secure the inverter cover with the four M5 captive screws.
Use either a 4-5 mm flat bladed screwdriver or a 2pt Pozidrive Head screwdriver.

2.3.3 Layout of MICROMASTER 411

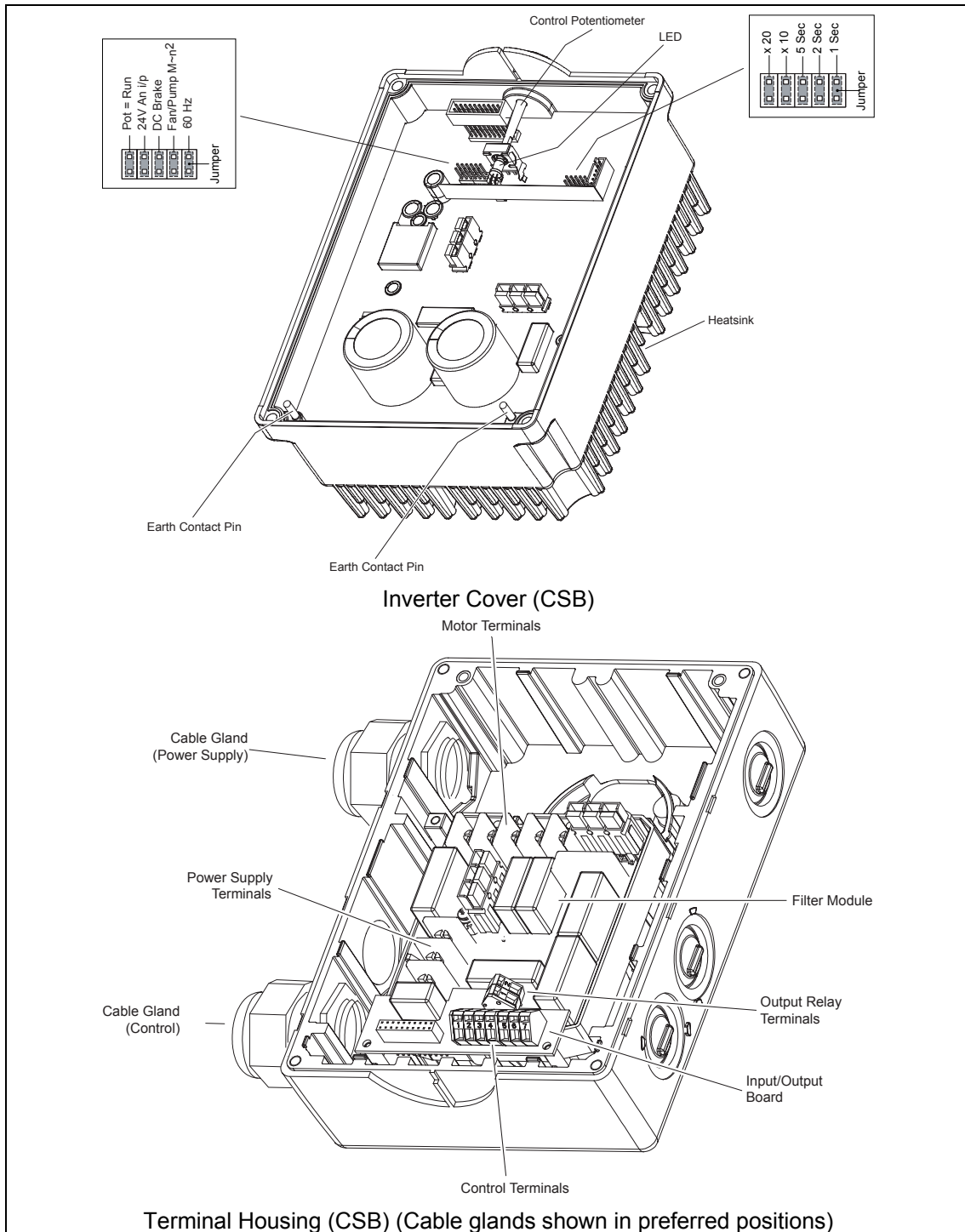

Figure 2-2 MICROMASTER 411, Internal Layout

MICROMASTER 411 Dimensional Detail

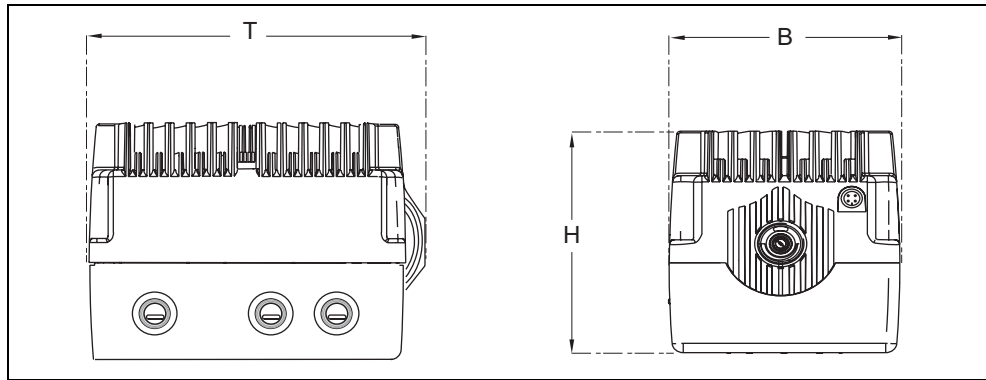

Figure 2-3 MICROMASTER 411 Case Size B Dimensions

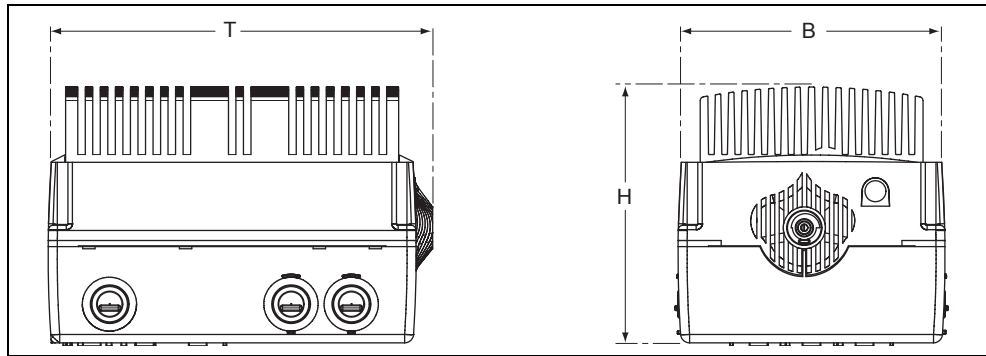

Figure 2-4 MICROMASTER 411 Case Size C Dimensions

Table 2-1 MICROMASTER 411 Dimension Detail

Case Size	Height (H)	Width (W)	Depth (D)	Weight	Power Range
	mm (Inches)	mm (Inches)	mm (Inches)	kg (lbs)	kW (hp)
B	135.6 (5.31)	154 (6.06)	222 (8.74)	4.9 (10.77)	0.37 – 1.5 (0.5 – 2.0)
C	170.6 (6.61)	177 (6.97)	255 (10.04)	7.4 (16.34)	2.2 – 3.0 (3.0 – 4.0)

2.3.4 Installation of Cable Glands

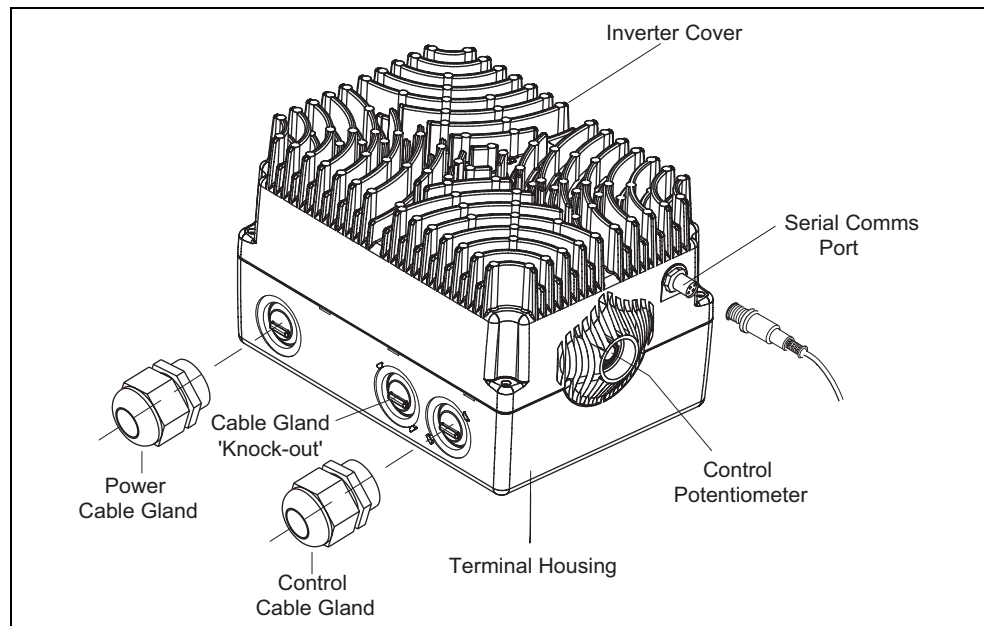

Figure 2-5 Cable Glands

Before power and control cables can be connected to their respective circuits it will first be necessary to fit the cable glands supplied.

Each gland should be located ideally to allow for convenient cable runs to the terminals located on the Filter and I/O boards.

1. Using a hammer and a flat-head screwdriver as shown in Figure 2-6 strike the gland plate or 'knockout' to obtain a clearance for the 25 mm cable gland.

NOTE

Care must be taken to prevent damage to the Terminal Housing, as this may affect the IP rating of the inverter.

2. Remove any sharp edges from the gland area and any swarf from the terminal housing.
3. After the knockout has been removed it should be safely discarded and the cable glands fitted as shown in Figure 2-6.

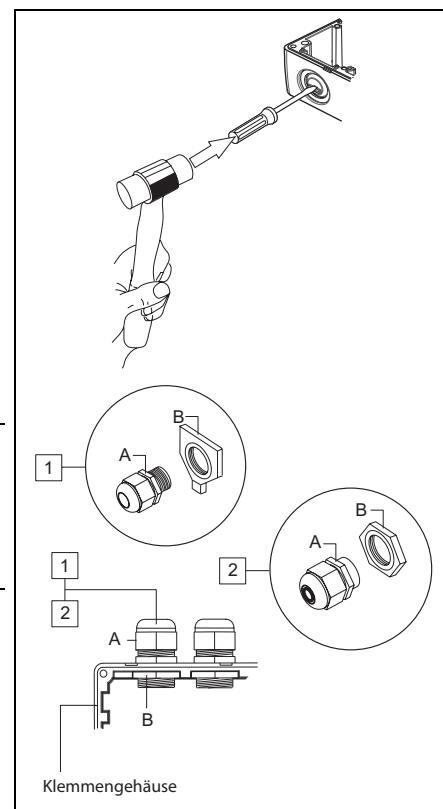

Figure 2-6 Installation of Cable Gland

MICROMASTER 411 – Cable Gland Dimensions

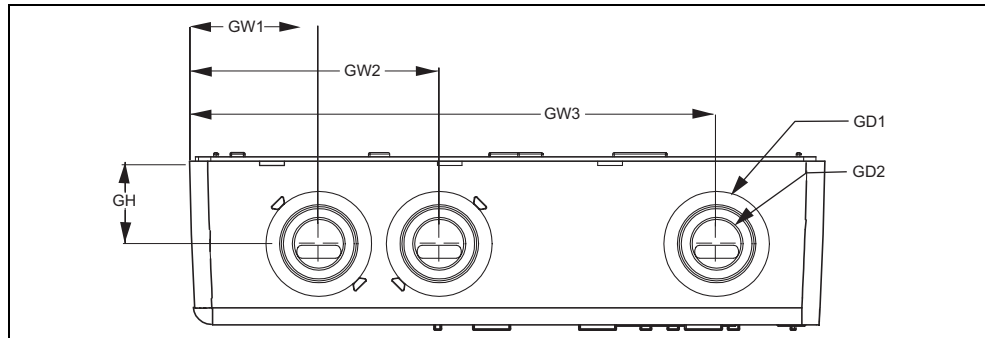

Figure 2-7 MICROMASTER 411 Gland Dimensions

Table 2-2 Gland Plate Detail

Case Size	GW1	GW2	GW3	GH	GD1	GD2
	mm (inch)	mm (inch)	mm (inch)	mm (inch)	mm (inch)	mm (inch)
B	42,9 (1,68)	82,9 (3,26)	175,0 (6,89)	27,6 (1,09)	35 (1,38)	26 (1,02)
C	43,0 (1,69)	83,0 (3,27)	203,4 (8,01)	38,3 (1,51)	36 (1,42)	26 (1,02)

2.3.5 Mounting the Inverter on a 1LA7 and 1LA9 Siemens Motor

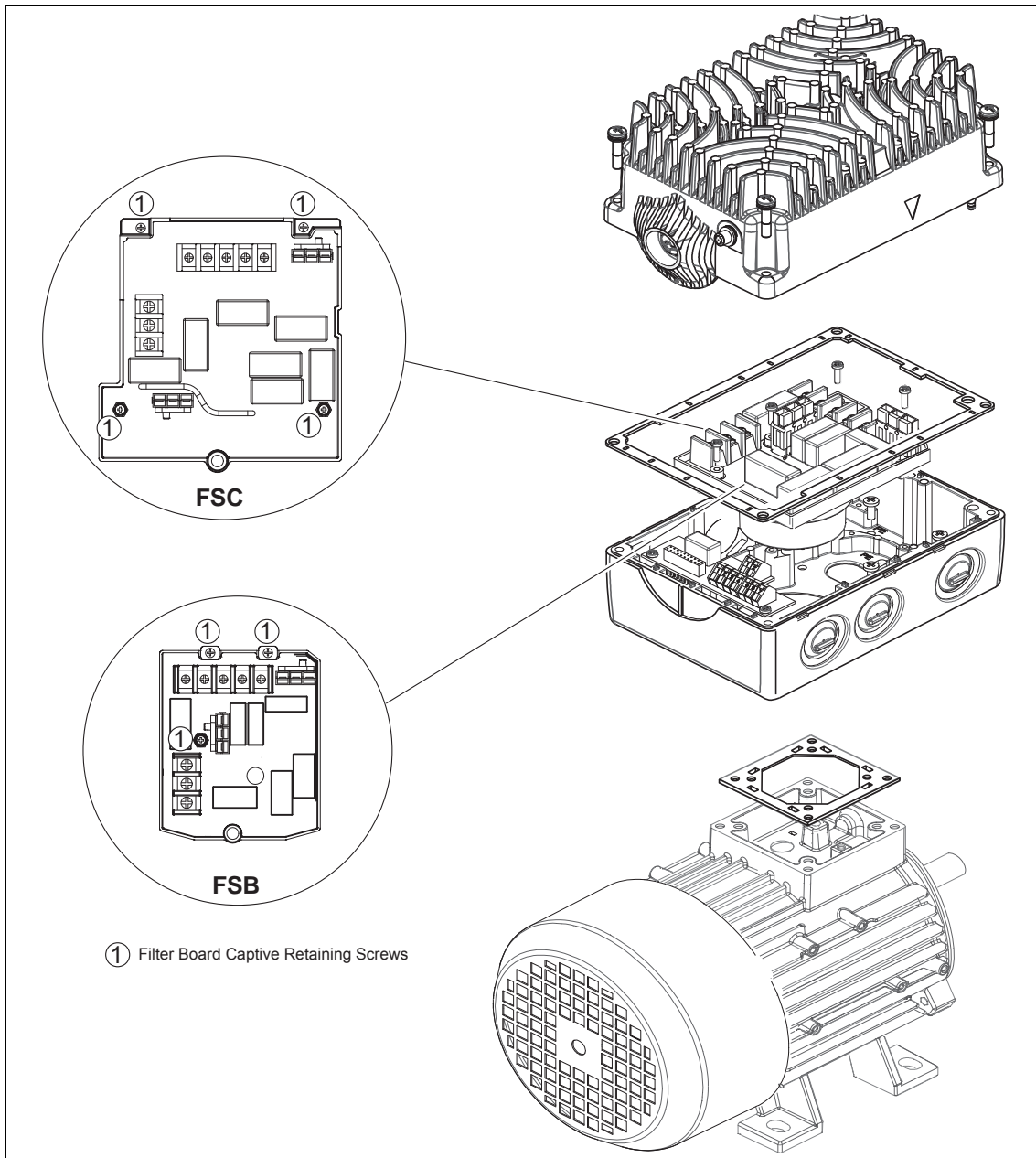

Figure 2-8 Mounting the Inverter on a 1LA7 and 1LA9 Siemens Motor

2.3.6 Wall Mounting the Inverter

Wall mounting of MICROMASTER 411 see Section 8.5.

2.4 Mechanical Installation COMBIMASTER 411

2.4.1 COMBIMASTER 411 Installation Procedure

Ensure that any lifting eyes are tightened down prior to moving the COMBIMASTER into position.

Use the lifting eyes provided if a motor has to be lifted. Always check the capacity of the hoist before lifting any equipment.



WARNING

Do not attempt to lift the COMBIMASTER 411 using the inverter housing as this could result in severe damage to the inverter or motor and possibly severe personal injury.

Move the COMBIMASTER 411 into the required position and secure by inserting suitable foundation bolts through the motor feet (see Figure 2-9 and Figure 2-10). Allow adequate clearance of 100 mm minimum around the unit to provide for air circulation.

COMBIMASTER 411 is supplied with a Power Supply Gland fitted to the preferred cable entry port. Should it become necessary to select other cable entry ports for either Power supply or Control then cable glands must be removed and the redundant port blanked off. Always remember to remove Inverter electronics before knocking out blanking plates. Blank off all redundant cable ports.

**CAUTION**

Do not knock out cable gland blanking plates unless inverter 'electronics' (Filter & I/O boards) have been removed.

Carry out the following checks prior to commissioning the COMBIMASTER 411:

1. The rotor is correctly aligned and free to rotate without obstruction.
2. Transmission elements are adjusted correctly (e.g. belt tensioned) and suitable for the given operating conditions.
3. All electrical connections, mounting screws and connecting elements tightened and fitted correctly.
4. Protective conductors installed properly
5. Any auxiliary equipment that might be fitted (e.g. mechanical brake) is in working order.
6. Protection guards are installed around all moving and live parts and any relevant safety notices displayed.

2.4.2 COMBIMASTER 411 Construction Type IM B 3

Inverter - Case Size B

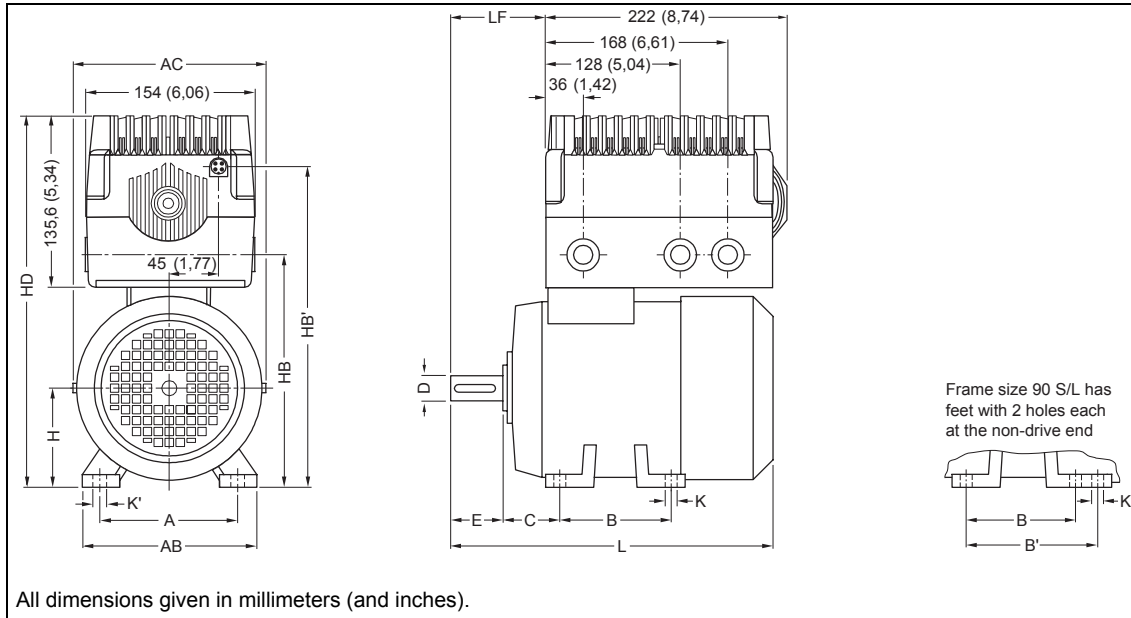

Figure 2-9 COMBIMASTER 411– Construction Type IM B 3 – Case Size B

Table 2-3 COMBIMASTER 411– Construction Type IM B 3 – Case Size B

Motor data		Dimensions								
Frame Size	Type	IEC DIN	A b	AB f	AC g	B a	B' a'	C w ₁	D d	E l
71	1UA1 07		112 (4,41)	132 (5,20)	145 (5,71)	90 (3,54)	- -	45 (1,77)	14 (0,55)	30 (1,18)
80	1UA1 08		125 (4,92)	150 (5,91)	163 (6,42)	100 (3,94)	- -	50 (1,97)	19 (0,75)	40 (1,57)
90 S	1UA1 090		140 (5,51)	165 (6,50)	180 (7,09)	100 (3,94)	125 (4,92)	56 (2,20)	24 (0,94)	50 (1,97)
90 L	1UA1 096-4									
Frame Size	Type	IEC DIN	H h	HB v	HB' v'	HD p	K s	K' s ₁	L k	LF q
71	1UA1 07		71 (2,80)	172 (6,77)	234,6 (9,24)	278,6 (10,97)	7 (0,28)	10 (0,39)	240 (9,45)	54 (2,13)
80	1UA1 08		80 (3,15)	190 (7,48)	252,6 (9,94)	296,6 (11,68)	9,5 (0,37)	13,5 (0,53)	273,5 (10,77)	64 (2,52)
90 S	1UA1 090		90 (3,54)	208 (8,19)	270,6 (10,65)	314,6 (12,39)	10 (0,39)	14 (0,55)	331 (13,03)	89,5 (3,52)
90 L	1UA1 096-4									

All dimensions given in millimeters (and inches).

Inverter - Case Size C

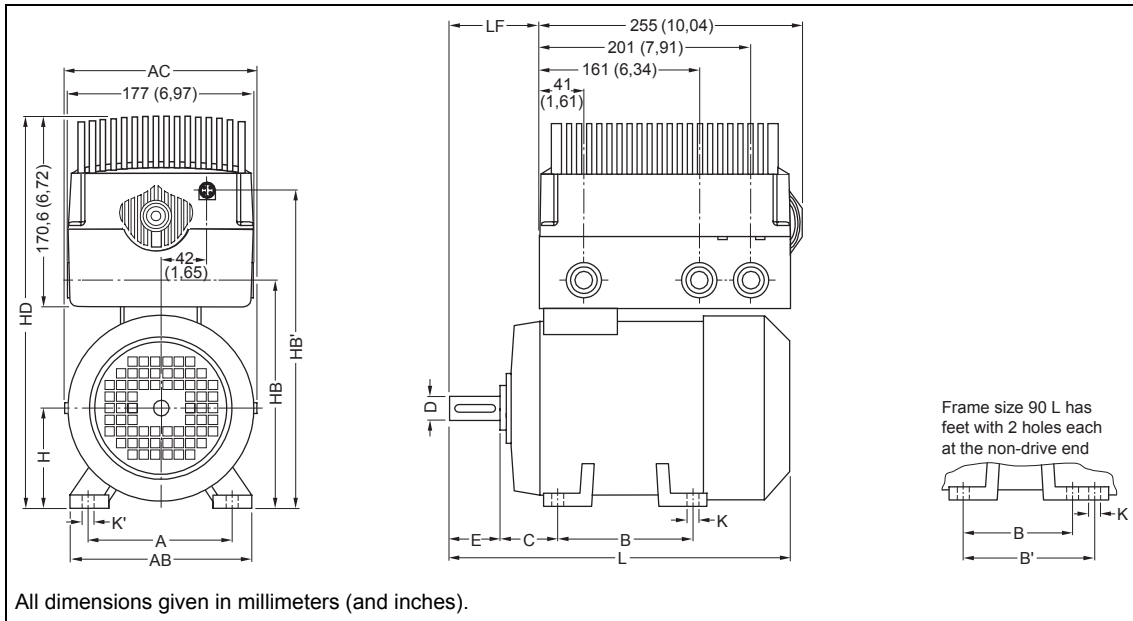

Figure 2-10 COMBIMASTER 411– Construction Type IM B 3 – Case Size C

Table 2-4 COMBIMASTER 411– Construction Type IM B 3 – Case Size C

Motor data		Dimensions								
Frame Size	Type	IEC DIN	A b	AB f	AC g	B a	B' a'	C w ₁	D d	E l
90L	1UA1 096-2		140 (5,51)	165 (6,50)	180 (7,09)	100 (3,94)	125 (4,92)	56 (2,20)	24 (0,94)	50 (1,97)
100L	1UA1 106		160 (6,30)	196 (7,72)	203 (7,99)	140 (5,51)	-	63 (2,48)	28 (1,10)	60 (2,36)
Frame Size	Type	IEC DIN	H h	HB v	HB' v'	HD p	K s	K' s ₁	L k	LF q
90L	1UA1 096-2		90 (3,54)	208 (8,19)	280 (11,02)	349,5 (13,76)	10 (0,39)	14 (0,55)	331 (13,07)	88,5 (3,48)
100L	1UA1 106		100 (3,94)	225 (8,86)	300 (11,81)	370 (14,57)	12 (0,47)	16 (0,63)	372 (14,69)	98 (3,86)

All dimensions given in millimeters (and inches).

2.4.3 COMBIMASTER 411 Construction Type IM B 5

Inverter - Case Size B

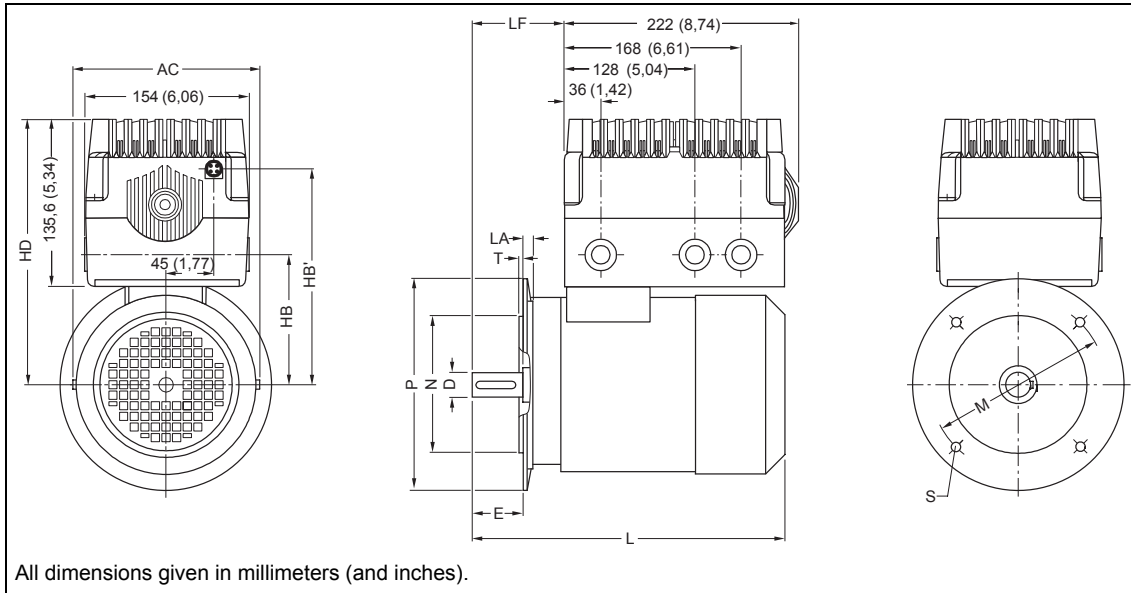

Figure 2-11 COMBIMASTER 411– Construction Type IM B 5 – Case Size B

Table 2-5 COMBIMASTER 411– Construction Type IM B 5 – Case Size B

Motor data		Dimensions							
Frame Size	Type	IEC DIN	AC g	D d	E l	HB v	HB' v ₁	HD p	L k
71	1UA1 07		145 (5,71)	14 (0,55)	30 (1,18)	101 (3,98)	163,6 (6,44)	207,6 (8,17)	240 (9,45)
80	1UA1 08		163 (6,42)	19 (0,75)	40 (1,57)	110 (4,33)	172,6 (6,80)	216,6 (8,53)	273,5 (10,77)
90 S	1UA1 090		180	24	50	118	180,6	224,6	331
90 L	1UA1 096-4		(7,09)	(0,94)	(1,97)	(4,65)	(7,11)	(8,84)	(13,03)
Frame Size	Type	IEC DIN	LA c ₁	LF q	M e ₁	N b ₁	P a ₁	S s ₂	T f ₁
71	1UA1 07		9 (0,35)	54 (2,13)	130 (5,12)	110 (4,33)	160 (6,30)	10 (0,39)	3,5 (0,14)
80	1UA1 08		10 (0,39)	64 (2,52)	165 (6,50)	130 (5,12)	200 (7,87)	12 (0,47)	3,5 (0,14)
90 S	1UA1 090		10	89,5	165	130	200	12	3,5
90 L	1UA1 096-4		(0,39)	(3,52)	(6,50)	(5,12)	(7,87)	(0,47)	(0,14)

All dimensions given in millimeters (and inches).

Inverter - Case Size C

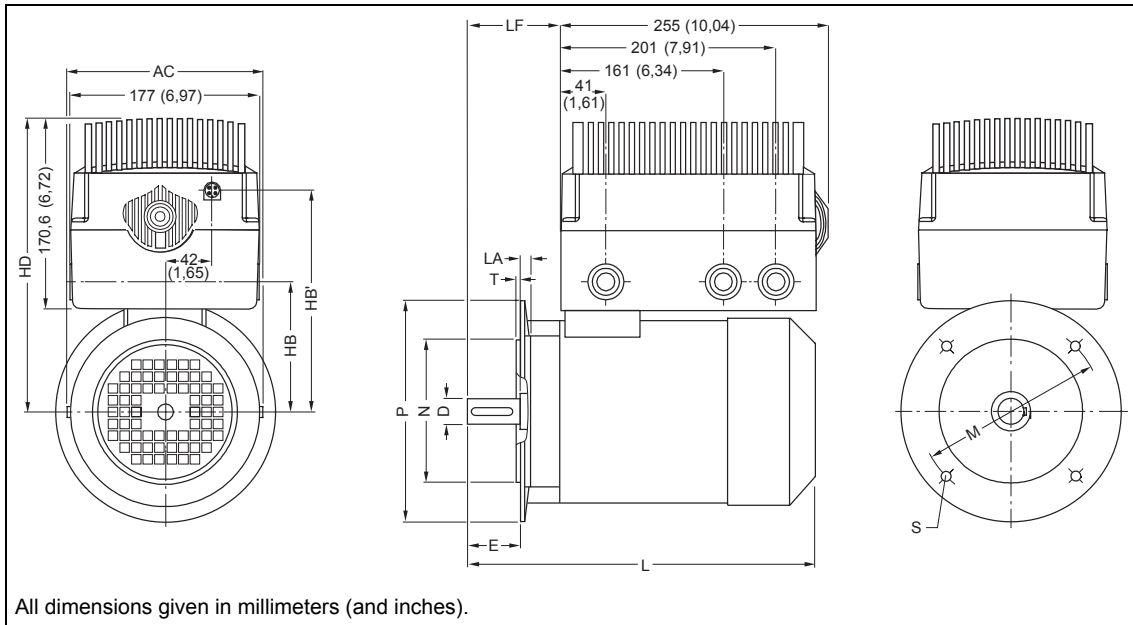

All dimensions given in millimeters (and inches).

Figure 2-12 COMBIMASTER 411– Construction Type IM B 5 – Case Size C

Table 2-6 COMBIMASTER 411– Construction Type IM B 5 – Case Size C

Motor data		Dimensions							
Frame Size	Type	IEC DIN	AC g	D d	E l	HB v	HB' v ₁	HD p	L k
90L	1UA1 096-2		180 (7,09)	24 (0,94)	50 (1,97)	118 (4,65)	190 (7,48)	259,5 (10,22)	331 (13,03)
100L	1UA1 106		203 (7,99)	28 (1,10)	60 (2,36)	125 (4,92)	200 (7,87)	270 (10,63)	372 (14,65)
Frame Size	Type	IEC DIN	LA c ₁	LF q	M e ₁	N b ₁	P a ₁	S s ₂	T f ₁
90L	1UA1 096-2		10 (0,39)	88,5 (3,48)	165 (6,50)	130 (5,12)	200 (7,87)	12 (0,47)	3,5 (0,14)
100L	1UA1 106		11 (0,43)	64 (2,52)	215 (8,46)	180 (7,09)	250 (9,84)	14,5 (0,57)	4 (0,16)

All dimensions given in millimeters (and inches).

2.5 Electrical Installation



WARNING

This equipment must be grounded.

- To ensure the safe operation of the equipment, it must be installed and commissioned by qualified personnel in full compliance with the warnings laid down in these operating instructions.
- Take particular note of the general and regional installation and safety regulations regarding work on dangerous voltage installations (e.g. EN 50178), as well as the relevant regulations regarding the correct use of tools and personal protective gear.
- Never use high voltage insulation test equipment on cables connected to the inverter.
- Power supply and motor terminals can carry dangerous voltages even if the inverter is inoperative; wait 5 minutes to allow the unit to discharge after switching off before carrying out any installation work.

CAUTION

The control and power supply cables must be laid separately. Do not feed them through the same cable conduit/trunking.

2.5.1 General



CAUTION

The inverter must always be grounded. If the inverter is not grounded correctly, extremely dangerous conditions may arise within the inverter which could prove potentially fatal.

Operation with Residual Current Device

If an RCD (also referred to as ELCB or RCCB) is fitted, the MICROMASTER 411 Inverters will operate without nuisance tripping, provided that:

- A type B RCD is used
- The trip limit of the RCD is 300 mA.
- The neutral of the supply is grounded.
- Only one inverter is supplied from each RCD.

Operation with long cables

All inverters will operate at full specification with cable lengths of 5 m..

2.5.2 Line and Motor Connections



WARNING

This equipment must be grounded.

- Isolate the electrical power supply before making or changing connections to the unit.
 - MICROMASTERS must not be connected to a higher voltage supply.
 - Ensure that the motor is configured for the correct supply voltage 380 V to 480 V three-phase supply.
 - When synchronous motors are connected or when coupling several motors in parallel, the inverter must be operated with voltage/frequency control characteristic (P1300 = 0, 2 or 3).
-



CAUTION

After connecting the power and motor cables to the proper terminals, make sure that the cover has been replaced properly before supplying power to the unit!

NOTICE

- Ensure that the appropriate circuit-breakers/fuses with the specified current rating are connected between the power supply and inverter (see Section Fuses).
 - Use Class 1 75°C copper wire only. For tightening torque see Section Tightening Torque.
 - To tighten up the power terminal screws use either a 4-5 mm flat bladed screwdriver or a 2pt Pozidrive Head screwdriver.
-

Access to the power and motor terminals

The procedure for accessing the power and motor terminals on the COMBIMASTER 411 & MICROMASTER 411 Inverter is illustrated in Figure 2-13.

Power Connections

The information given in Figure 2-13 shows the connection of the motor wires to the filter board terminals. Power cables should be connected to the inverter terminals as detailed in the following procedure.

For cable size and rating refer to Section Tightening Torque

1. If the Inverter cover (the top-half) has already been fitted, unscrew the four M5 cross-head captive screws on the inverter cover.
2. Remove inverter (cover) to access the connection terminals.
3. Feed the power cable into the terminal housing via the appropriate gland hole.
4. Connect power leads to terminals L1, L2, L3 and to the separate earth.

To avoid snagging on components when the inverter halves are brought together, run cables along the base of the terminal housing.

5. Use Class 1 75° C copper wire only. Use a 4-core cable. If crimp terminals are used they must be insulated. If crimps are not used, the strip length must not exceed 5 mm. Use a 4 - 5 mm cross-tip screwdriver to tighten the terminal screws.
6. Recommended tightening torque for power supply terminals is as given in Section Tightening Torque.
7. A 'drip loop' is recommended when connecting the mains and control cables.
8. Ensure that the power source provides the correct voltage and is designed for the rated current. Use appropriate circuit-breakers with specified current rating between the power supply and inverter.
9. Ensure the appropriate circuit breakers/fuses with the specified current rating are connected between the power supply and the inverter. (See Section Fuses).



WARNING

- It is essential that the Inverter be correctly earthed to the motor earth. Severe injury may result if the motor is not correctly earthed.
 - If the Inverter is being installed after a period of storage please refer to the information in Section 2.1.
-

Motor Connections for Star/Delta

The information given in Figure 2-13 also shows the connection of motor wires to the filter board inverter/motor terminals. Motor wires should be connected in either star or delta configuration in accordance with the motor rating plate. For cable size and rating refer to Section Tightening Torque.

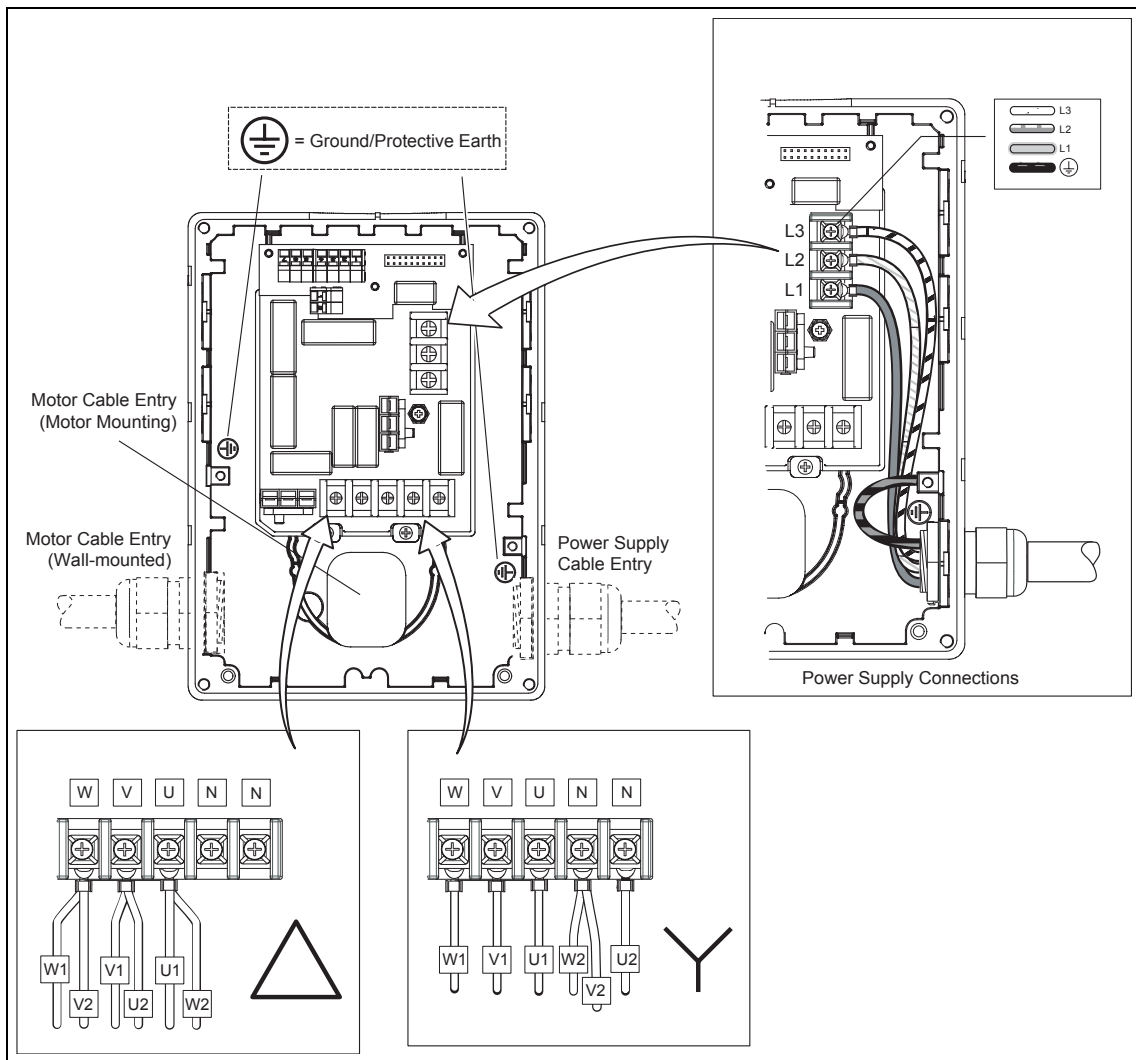

Figure 2-13 Motor and Power Supply Connections

2.5.3 Control Cable Connections

1. Feed the control cables into the inverter via one of the gland holes at the I/O module end of the terminal housing.
2. Run the control cable underneath the I/O board toward the control terminals.
3. Connect the control wires in accordance with the terminal information given in Figure 2-14.
4. Use screened cable for all control wiring.

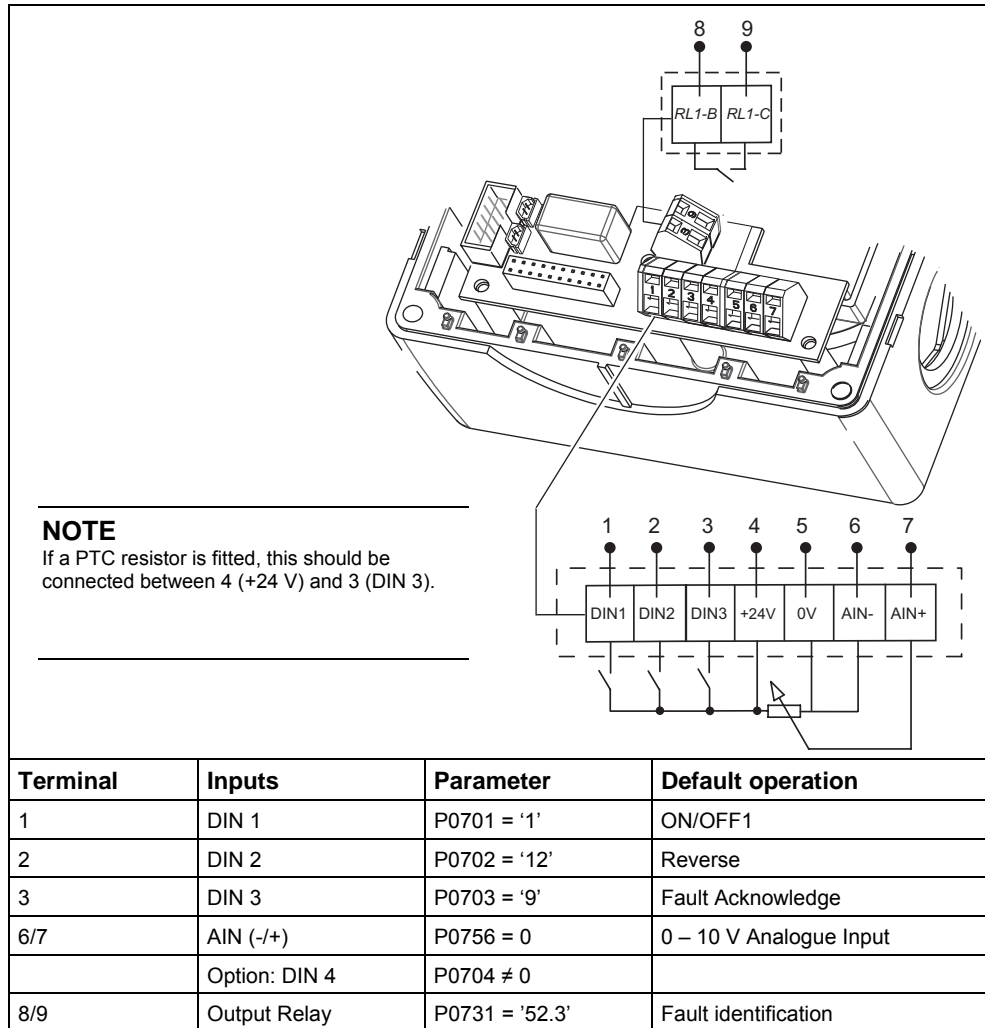

Figure 2-14 Control Terminals

2.5.4 Motor PTC Connections

In order for the inverter to monitor the motor PTC (if fitted) it will be necessary to connect the Motor PTC to the Inverter Digital input 3 (DIN3) terminal.

Connect the Motor PTC extension cable (not provided with the Inverter) between the Inverter I/O terminals 3 & 4 and the Motor PTC terminals within the motor terminal housing. The arrangement is as shown in Figure 2-15).

NOTE

DIN 3 must be configured to read the PTC input [(P0703 = 29) (external trip)]

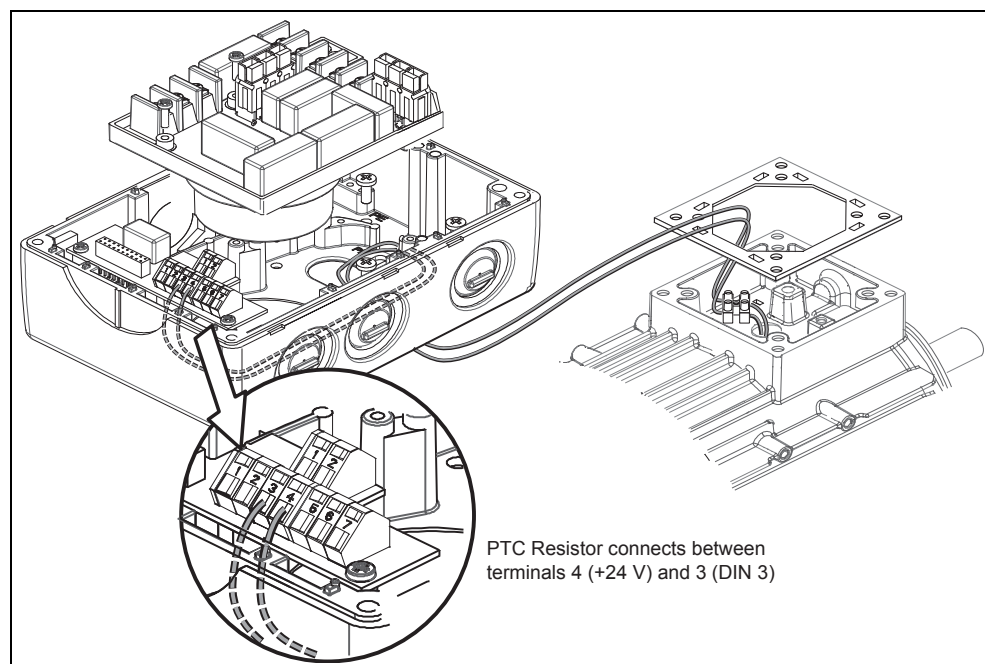

Figure 2-15 PTC Connections

2.5.5 Avoiding Electro-Magnetic Interference

The inverters are designed to operate in an industrial environment where a high level of EMI can be expected. Usually, good installation practices will ensure safe and trouble-free operation. If you encounter problems, follow the guidelines stated below.

Action to Take

- Make sure that any control equipment connected to the inverter (such as a PLC) is connected to the same ground or star point as the inverter via a short, thick link.
- Flat conductors are preferred as they have lower impedance at higher frequencies.
- **Separate the control cables from the power connections as much as possible, using separate trunking, if necessary at 90° right angles.**
- Ensure that contactors are suppressed, either with R-C suppressors for AC contactors, or 'flywheel' diodes for DC contactors, **fitted to the coils**. Varistor suppressors are also effective. This is important when the contactors are controlled from the inverter relay.
- Screened motor cables should be used when the motor is mounted separately from the inverter.
- Maximum motor cable length is 5 meters (16.40 feet).



WARNING

Safety regulations **must not** be compromised when installing inverters!

3 Commissioning

This Chapter contains:

- A schematic diagram of the MICROMASTER 411 / COMBIMASTER 411
- An overview of the commissioning options and the display and operator panels
- An overview of quick commissioning of the MICROMASTER 411 / COMBIMASTER 411

3.1	Block Diagram.....	49
3.2	General Information	50
3.3	Commissioning Procedure Overview.....	51
3.3.1	Control Circuit Jumpers	52
3.3.2	Ramp Times Using Jumpers	54
3.3.3	Default setup.....	55
3.3.4	Commissioning Overview with BOP or AOP	56
3.3.4.1	Commissioning with the Basic Operator Panel (BOP)	57
3.3.4.2	Commissioning with the Advanced Operator Panel (AOP)	60
3.3.4.3	Quick commissioning (P0010=1).....	60
3.3.4.4	Reset to Factory default.....	62
3.4	General operation	63
3.4.1	Default Operation.....	63
3.4.2	Operation using “Pot = Run” Jumper.....	64
3.4.3	Non - Default Modes of Operation	65
3.4.4	If the Motor does not start up.....	66
3.4.5	If a fault occurs.....	66



WARNING

- COMBIMASTER411/MICROMASTER 411 operates at high voltages.
 - When operating electrical devices, it is impossible to avoid applying hazardous voltages to certain parts of the equipment.
 - Emergency Stop facilities according to EN 60204 IEC 204 (VDE 0113) must continue to function in all operating modes of the control equipment. Any disengagement of the Emergency Stop facility must not lead to uncontrolled or undefined restart.
 - Wherever faults occurring in the control equipment may lead to substantial material damage, or even grievous bodily injury, (i.e. potentially dangerous faults), additional external precautions must be taken or facilities provided to ensure or enforce safe operation, even when a fault occurs (e.g. independent limit switches, mechanical interlocks, etc.).
 - Certain parameter settings may cause the inverter to restart automatically after an input power failure.
 - Motor parameters must be accurately configured for motor overload protection to operate correctly.
 - This equipment is capable of providing internal motor overload protection in accordance with UL508C. Refer to P0610 (level 3) and P0335, I²T is ON by default. Motor overload protection can also be provided using an external PTC via a digital input.
 - This equipment is suitable for use in a circuit capable of delivering not more than 10,000 symmetrical amperes (rms), for a maximum voltage of 460 V when protected by an H, J or K type fuse, a circuit breaker or self-protected combination motor controller.
 - This equipment must not be used as an 'emergency stop mechanism' (see EN 60204, 9.2.5.4).
-



CAUTION

Only qualified personnel may enter settings in the control panels. Particular attention must be paid to safety precautions and warnings at all times.

The COMBIMASTER 411 & MICROMASTER 411 is supplied with default parameter settings that cover the following requirements:

- The motor rating data, voltage, current and frequency are all compatible with the inverter data.
- Linear V/f motor speed, controlled by the control potentiometer.
- Maximum speed 3000 min⁻¹ with 50 Hz (3600 min⁻¹ with 60 Hz), controllable via the control potentiometer or by using a potentiometer via the inverter's analogue input.
- Ramp-up time / Ramp-down time = 10 s.

If more complex application settings are required, please refer to the parameter listing.

To change parameters you will need one of the optional modules "Basic Operator Panel" (BOP), the "Advanced Operator Panel" (AOP) or the set-up software (on the Docu-CD supplied).

3.1 Block Diagram

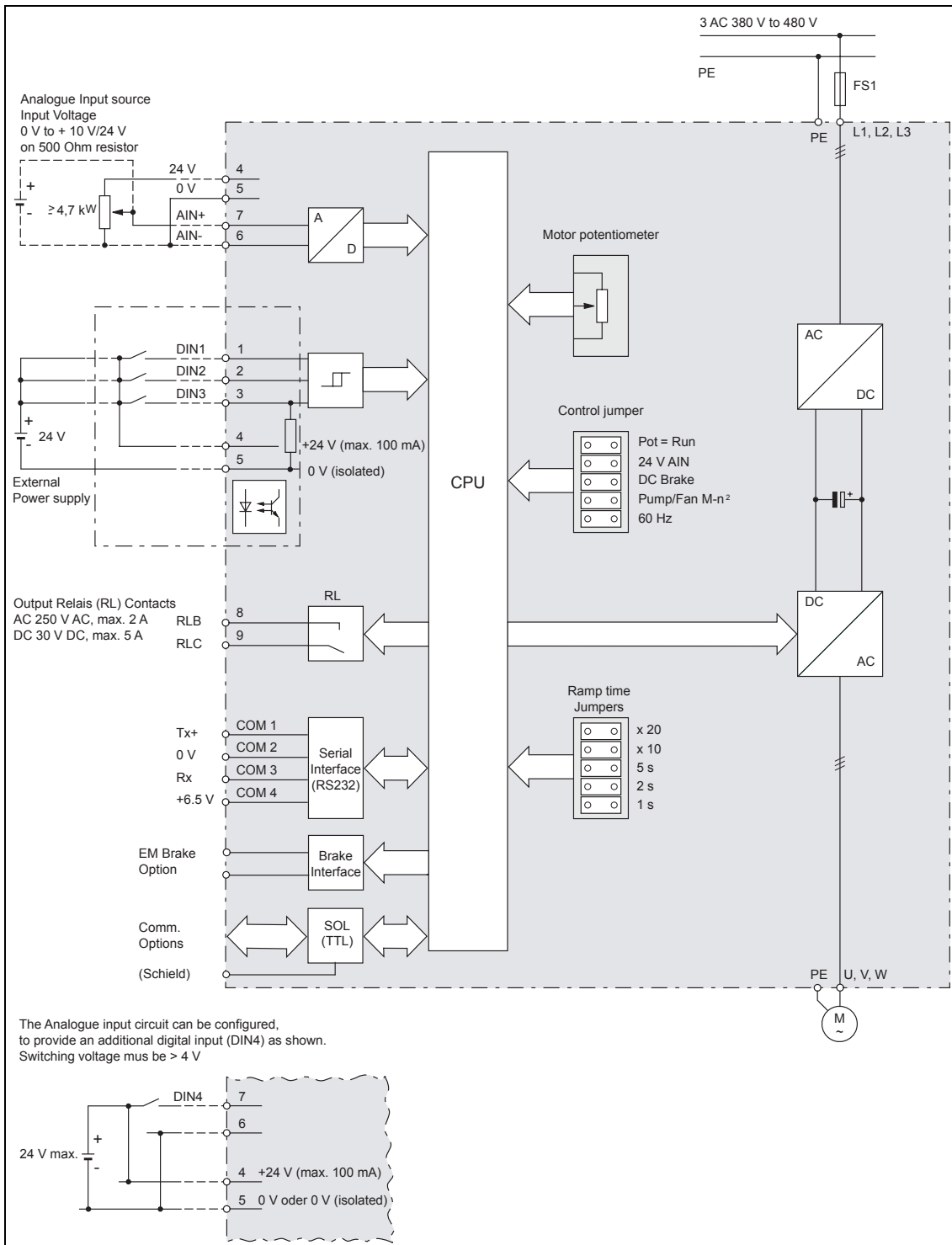

Figure 3-1 COMBIMASTER 411 & MICROMASTER 411 Block Diagram

3.2 General Information

For basic operation no additional equipment is required.

However, for more complex operation either the Basic Operator Panel (BOP), Advanced Operator Panel (AOP) or the set-up software contained on the Docu-CD is required.

Furthermore the COMBIMASTER 411/MICROMASTER 411 can be integrated into automation systems via communication modules (e.g. PROFIBUS module; option). In addition the COMBIMASTER 411 has a RS 232 interface.

When delivered the inverter has a frequency setpoint range of between 0 Hz and 50 Hz.



WARNING

The inverter does not have a power supply switch and is therefore live when the power supply is connected.

3.3 Commissioning Procedure Overview

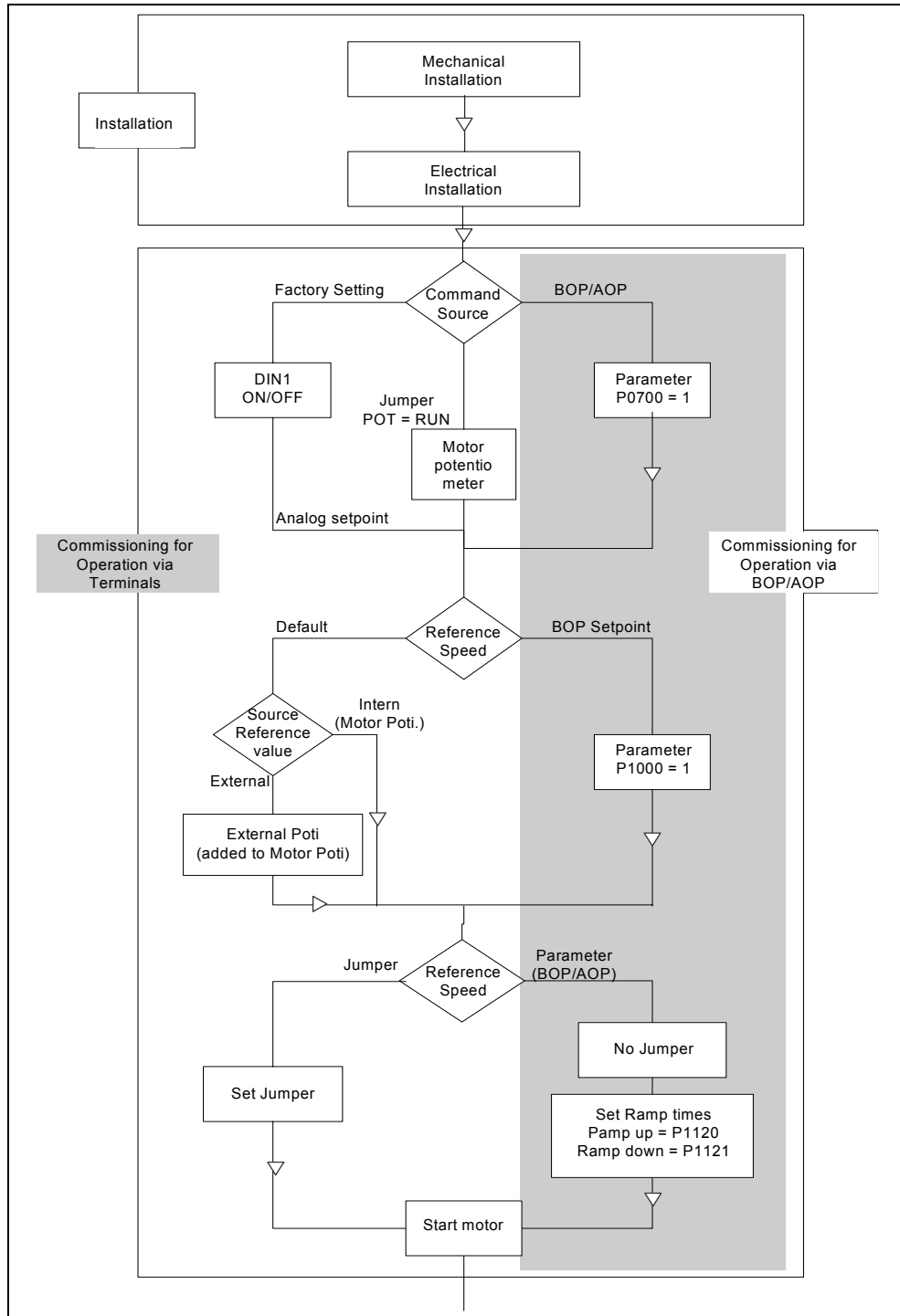

Figure 3-2 MICROMASTER 411 / COMBIMASTER 411 Commissioning Guide

3.3.1 Control Circuit Jumpers

Control Jumpers (see Table 3-1) are provided for the following functions (fit jumper to enable function). Jumpers can only be accessed when the cover is removed:

- Pot = Run
Enables the control potentiometer as the Command Source (auto restart is enabled).
- 24 V AIN
To change analogue input range from 0 –10 V to 0 – 24 V
- DC Brake
To change Stop function from OFF1 to DC Brake.
- Fan/Pump: M~n2
To change V/f curve from Linear to Quadratic curve.
- 60 Hz operation
To change motor default settings from 50 Hz to 60 Hz.

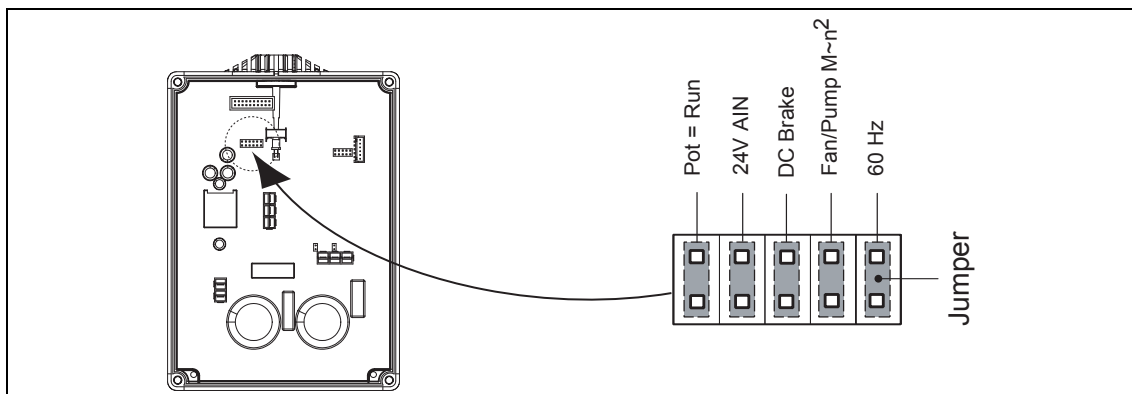

Figure 3-3 Control Circuit Jumpers

Table 3-1 Control Circuit Jumper Settings

Jumper	Jumper fitted	Jumper removed
Pot = Run	P0700 = 2 P0705 = 1 (motor potentiometer) P1210 = 6 automatic restart	P0700 = 2 P0701 = 1 P1210 = 1
24 AIN	No software effect	No software effect
DC Brake	Uses the jumper settings for the ramp settings by the duration of the direct current braking, to be calculated as follows. Duration of direct current braking = $P1121 \text{ (deceleration time)} * \frac{P0305 \text{ (nominal motor current)}}{r0207 \text{ (nominal inverter current)}}$ If the drive is quicker to come to a standstill because of the load conditions, the direct current braking still remains active for the calculated time. Otherwise the value is held in P1233 (duration of the direct current braking)	P1233 = 0
Fan/Pump: M~n2	P1300 = 2 (fan curve/quadratic vf)	P1300 = 0 (linear vf)
50/60 Hz	Rated Motor Frequency = 60 Hz	Rated Motor Frequency = 50 Hz

Table 3-2 Inverter behaviour when fitting or removing Control Circuit Jumpers

Status before action(s)	Action(s)	Reaction(s) of the inverter
Jumper not fitted	<ul style="list-style-type: none"> Power down Fit jumper(s) Power up 	Parameters influenced by jumper will have jumper default values
Jumper fitted	<ul style="list-style-type: none"> Cycle power 	Parameters influenced by jumper are not changed
Jumper fitted	<ul style="list-style-type: none"> Power down Remove jumper Power up 	Parameters influenced by jumper will have "jumper removed" default values (normally factory default)
Jumper not fitted	<ul style="list-style-type: none"> Cycle power 	Parameters influenced by jumper are not changed

3.3.2 Ramp Times Using Jumpers

Inverter ramp times are set using a series of 5 jumpers (fit jumper to enable function). Each jumper must be set as shown in Table 3-3.

The jumpers overwrite the default settings or the ramp times specified using BOP/AOP/IBN software.

The inverter recognizes when jumper values have been set when power is re-applied.

CAUTION

Jumpers have priority in setting ramp times. When the jumpers are removed the ramp times are not changed. It is then possible to change ramp times via the parameters (using the BOP).

Ramp times apply to Ramp Up and Ramp Down. Jumper locations are as shown in Figure 3-4.

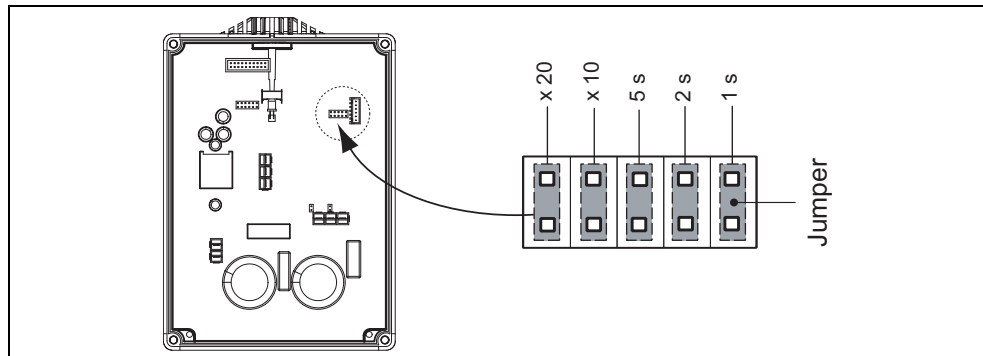

Figure 3-4 Ramp Time Jumpers

Using up to 5 jumpers allows ramp times to be set between 1 - 240 s. Also see Table 3-3.

Table 3-3 Ramp Time Adjustment Jumpers

Time [s]	X20	X10	5 s	2 s	1 s
1					x
2				x	
3				x	x
5			x		
6			x		x
7			x	x	
8			x	x	x
10		x		x	x
20		x		x	x
30		x			x
50		x	x		
60		x	x		x

Time [s]	X20	X10	5 s	2 s	1 s
70		x	x	x	
80		x	x	x	x
90	x	x		x	x
100	x		x		
120	x		x		x
140	x		x	x	
150	x	x	x		
160	x		x	x	x
180	x	x	x		x
210	x	x	x	x	
240	x	x	x	x	x

Behaviour of the Ramp Time Jumpers

In Table 3-4 the behaviour of the Ramp Time Jumpers are explained:

Table 3-4 Ramp Time Jumper Behaviour

Status before action(s)	Action(s)	Reaction(s) of the inverter
No jumper fitted Ramp times have arbitrary setting	<ul style="list-style-type: none"> • Power down • Fit jumper(s) • Power up 	Inverter uses the ramp times defined by the current jumper setting
At least one Jumper fitted Ramp times have arbitrary setting	<ul style="list-style-type: none"> • Power down • Power up 	Inverter uses the ramp times defined by the current jumper setting
At least one Jumper fitted Ramp times have arbitrary setting	<ul style="list-style-type: none"> • Power down • Remove jumper(s) • Power up 	Inverter uses the ramp times that were used before removing the jumper(s)

NOTE

The brake time is influenced by the setting for the ramp time (deceleration time). The following relationship applies:

$$\text{Braking time} = P1121 \text{ (deceleration time)} * \frac{P0305 \text{ (nominal motor current)}}{r0207 \text{ (nominal inverter current)}}$$

3.3.3 Default setup

To change parameters it is necessary to use a Basic Operator Panel (BOP), Advanced Operator Panel (AOP) or an external serial interface with DriveMonitor or STARTER. The inverter is therefore delivered with the following default settings:

- Setpoint control from the Analog input in addition to Control Potentiometer.
- Supply frequency set for 0 to 50 Hz.
- Digital inputs:
 - DIN 1 ON/OFF1
 - DIN 2 Reverse
 - DIN 3 Fault Acknowledge
- Jumpers for Ramp and Control circuits set to open (default settings). Refer to sections 3.3.1 and 3.3.2.
- Relay – Fault conditions.

3.3.4 Commissioning Overview with BOP or AOP

Prerequisites

Mechanical and electrical Installation is completed.

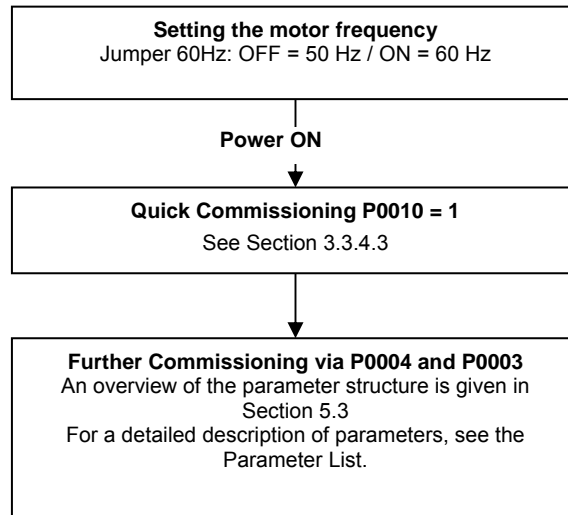

NOTE

We recommend the commissioning according this scheme.

3.3.4.1 Commissioning with the Basic Operator Panel (BOP)



The Basic Operator Panel (BOP), which is available as an optional accessory, provides the user with access to the inverter parameters and enables you to customize the settings of your COMBIMASTER 411 & MICROMASTER 411. The BOP is mounted in an Operator Panel Mounting Kit and connected to the COMBIMASTER 411 & MICROMASTER 411 via the serial interface (see Figure 3-9). The BOP can be used to configure several COMBIMASTER 411 & MICROMASTER 411 Inverters.

The BOP features a five-digit, seven-segment display for showing parameter numbers and values, alarm and fault messages and setpoints and actual values. Parameter sets cannot be saved via the BOP.

Control functions for the inverter (ON/OFF, , , reverse) are not active in the works settings. In order to specify this command via the BOP, P0700 = 1 must be set.

If the BOP connection is removed during normal running the drives is stopped and the motor coasts to standstill.

Table 3-5 Default Settings for BOP Operation

Parameter	Meaning	Default Europe (North America)
P0100	Operating Mode Europe/US	50 Hz, kW (60 Hz, hp)
P0307	Power (rated motor)	kW (Hp)
P0310	Motor frequency rating	50 Hz (60 Hz)
P0311	Motor speed rating	1395 (1680) rpm [depending on variant]]
P1082	Maximum Motor Frequency	50 Hz (60 Hz)

Buttons on the Basic Operator Panel

















Panel/Button	Function	Effects
	Indicates Status	The LCD displays the settings currently used by the inverter.
	Start motor	Pressing the button starts the inverter. This button is disabled by default. To enable this button set P0700 = 1.
	Stop motor	OFF1 Pressing the button causes the motor to come to a standstill at the selected ramp down rate. Disabled by default; to enable set P0700 = 1. OFF2 Pressing the button twice (or once long) causes the motor to coast to a standstill. This function is always enabled.
	Change direction	Press this button to change the direction of rotation of the motor. Reverse is indicated by a minus (-) sign or a flashing decimal point. Disabled by default, to enable set P0700 = 1.
	Jog motor	Pressing this button while the inverter has no output causes the motor to start and run at the preset jog frequency. The motor stops when the button is released. Pressing this button when the motor is running has no effect.
	Functions	This button can be used to view additional information. Pressing and holding the button for 2 seconds from any parameter during operation, shows the following: 1. DC link voltage (indicated by d – units V). 2. Output current. (A) 3. Output frequency (Hz) 4. Output voltage (indicated by o – units V). 5. The value selected in P0005 (If P0005 is set to show any of the above (1 to 4) then this will not be shown again). Additional presses will toggle around the above displays. Jump Function From any parameter (rXXXX or PXXXX) a short press of the Fn button will immediately jump to r0000, you can then change another parameter, if required. Upon returning to r0000, pressing the Fn button will return you to your starting point. Quit In case of a fault or alarm the  button resets the fault or alarm message on the operator panel display.
	Access parameters	Pressing this button allows access to the parameters.
	Increase value	Pressing this button increases the displayed value.
	Decrease value	Pressing this button decreases the displayed value.

Figure 3-5 Basic Operator Panel Controls

Changing parameters with the BOP

The procedure for changing the value of parameter P0004 is described below. Modifying the value of an indexed parameter is illustrated using the example of P0719. Follow exactly the same procedure to alter other parameters that you wish to set via the BOP.

Changing P0004 – parameter filter function

Step	Result on display
1 Press  to access parameters	r0000
2 Press  until P0004 is displayed	P0004
3 Press  to access the parameter value level	0
4 Press  or  to the required value	7
5 Press  to confirm and store the value	P0004
6 Only the command parameters are visible to the user.	

Changing P0719 an indexed parameter Selection of command/setpoint source









Step	Result on display
1 Press  to access parameters	r0000
2 Press  until P0719 is displayed	P0719
3 Press  to access the parameter value level	r0000
4 Press  to display current set value	0
5 Press  or  to the required value	12
6 Press  to confirm and store the value	P0719
7 Press  until r0000 is displayed	r0000
8 Press  to return the display to the standard drive display (as defined by the customer)	

Figure 3-6 Changing parameters via the BOP

NOTE

In some cases - when changing parameter values - the display on the BOP shows **buSY**. This means the inverter is busy with tasks of higher priority.

Changing single digits in Parameter values

For changing the parameter value rapidly, the single digits of the display can be changed by performing the following actions:

Ensure you are in the parameter value changing level (see "Changing parameters with BOP").

1. Press **Fn** (function button), which causes the right hand digit to blink.
2. Change the value of this digit by pressing **▲** / **▼**.
3. Press **Fn** (function button) again causes the next digit to blink.
4. Perform steps 2 to 3 until the required value is displayed.
5. Press the **P** to leave the parameter value changing level.

NOTE

The function button may also be used to acknowledge a fault condition.

3.3.4.2 Commissioning with the Advanced Operator Panel (AOP)

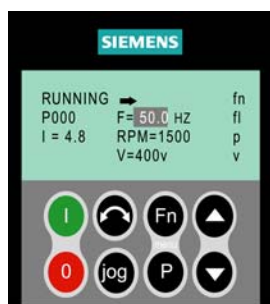

The Advanced Operator Panel (AOP) is available as an option. Its advanced features include the following:

- Multilingual clear text display
- Upload/download facility for multiple parameter sets
- Programmable via PC
- Multidrop capability to drive up to 30 MICROMASTER 4's

Please refer to the AOP Manual for details or contact your local Siemens sales office for assistance.

3.3.4.3 Quick commissioning (P0010=1)

Mechanical and electrical installation of the inverter must be completed before running „Quick Commissioning“.

It is **important** that the parameter P0010 is used for commissioning and P0003 for selecting the parameter level (level). Quick commissioning particularly uses parameters concerning the motor data and the acceleration and deceleration times. Quick commissioning is ended with P3900. If this parameter is set to 1, it makes the required motor calculations and sets all parameters which are not part of the quick commissioning to the default values.

NOTE

Parameter P0399 = 0 must be set before starting quick commissioning because it is not possible to change the motor data in the works default setting. Once quick commissioning has been completed, P0399 = 2 must be set.

Flow chart Quick Commissioning (Level 1 Only)

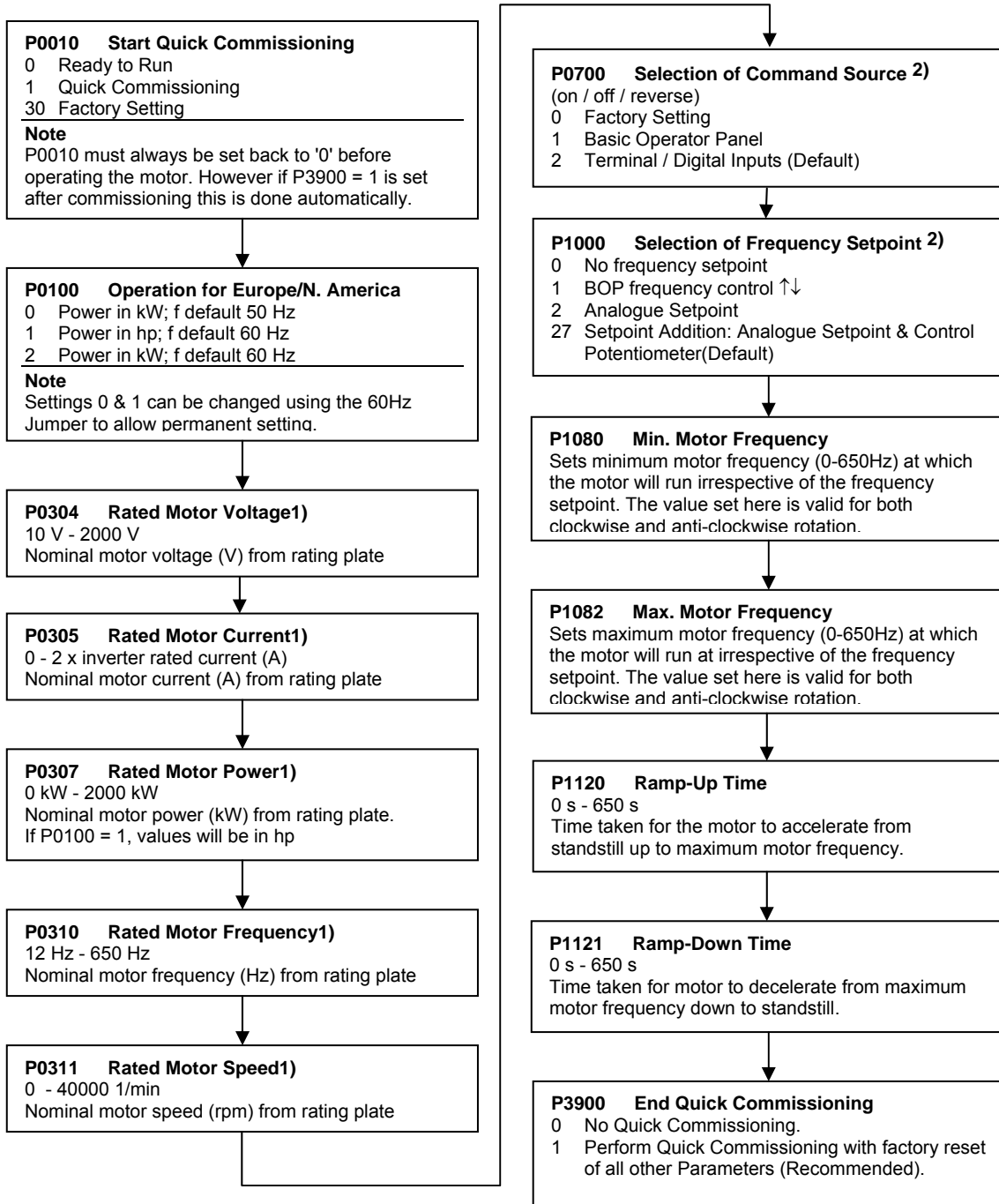

1) related parameters – please refer to motor rating plate drawing.

2) Denotes parameters that contain more detailed lists of possible settings for use in specific applications. Please refer to the Parameter List.

Motor data for parameterization

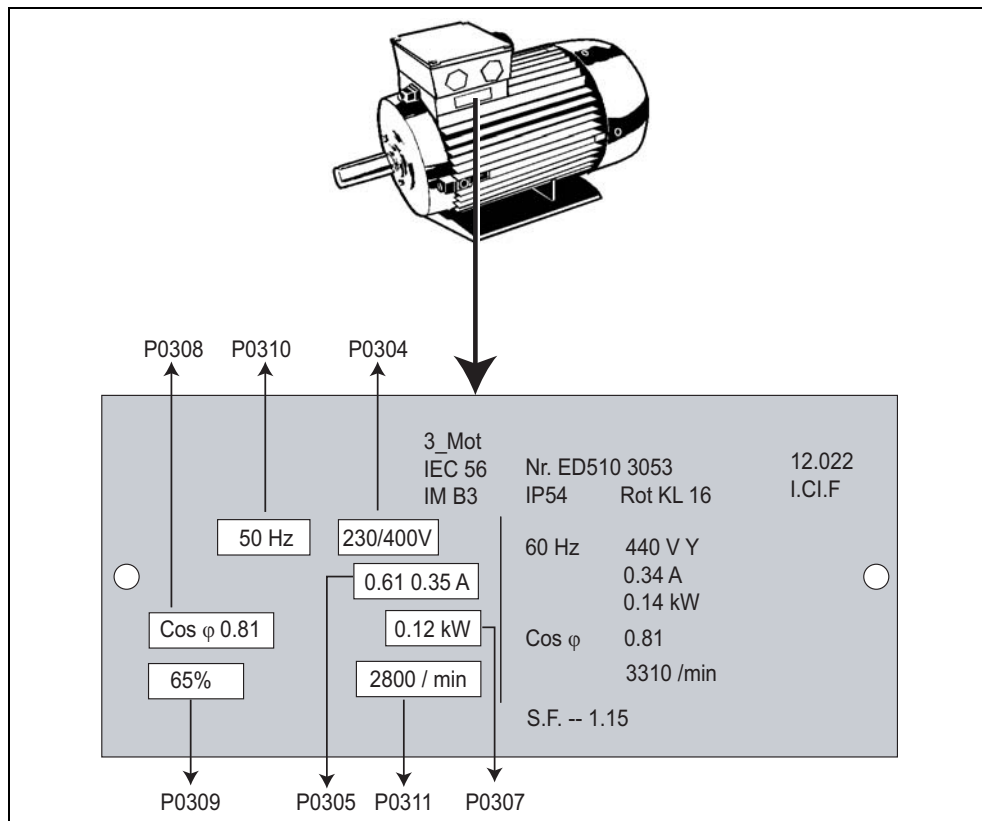

Figure 3-7 Typical Motor Rating Plate Example

NOTICE

- P0308 & P0309 are only visible if P0003 ≥ 2. Only one of the parameters is shown depending on the settings of P0100.
- Changing motor parameters is not possible unless P0010 = 1(factory setting) and P0004 = 0 or 3.
- Ensure that the inverter is configured correctly to the motor.

3.3.4.4 Reset to Factory default

To reset all parameters to the factory default settings; the following parameters should be set as follows:

1. Set P0010 = 30
2. Set P0970 = 1

NOTICE

1. The reset process can take up to 3 minutes to complete.
2. Refer to Parameter P0399 for description on saving motor data sets while performing a reset to the factory defaults.

3.4 General operation

For a full description of standard and extended parameters refer to the Parameter List.

NOTICE

1. The inverter does not have a main power switch and is live when the power supply is connected. It waits, with the output disabled, until the RUN button is pressed or for the presence of a digital ON signal at terminal 1 (ON/OFF1).
2. If a BOP or an AOP is fitted and the output frequency is selected to be displayed (P0005 = 21) the corresponding setpoint is displayed approximately every 1.0 seconds while the inverter is stopped.
3. The inverter is programmed at the factory for standard applications on Siemens four-pole standard motors that have the same power rating as the inverters. When using other motors it is necessary to enter the specifications from the motor's rating plate. See Figure 3-7 for details on how to read motor data.
4. Changing motor parameters is not possible unless P0010 = 1 and P004 = 0 or 3.
5. You must set P0010 back to 0 in order to initiate a run.

3.4.1 Default Operation

For default operation, connect the terminals as shown in the figure below:

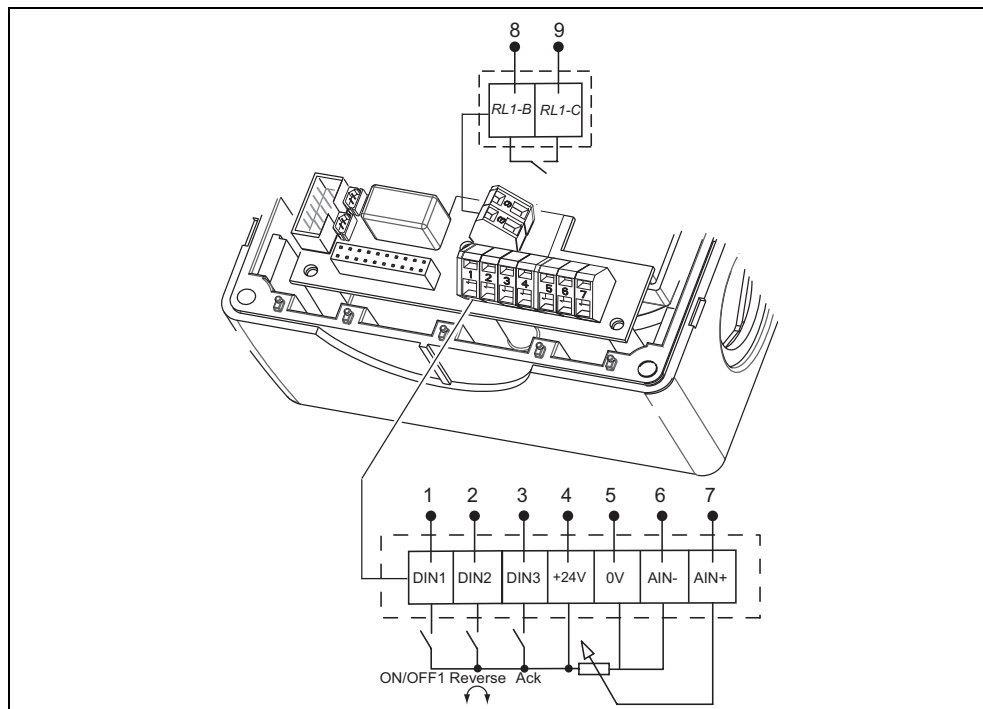

Figure 3-8 Default Setup Terminal Connections

FREQUENCY SETPOINT

Setpoint addition: Control potentiometer and Analog input (P1000 = 27).

In order to provide the unit with a Frequency Setpoint the user can either:

1. Turn the control potentiometer.
2. Fit an external potentiometer, or apply an external analog control voltage across the terminals 6 and 7 AIN.

NOTE

When using the analog input only, the control potentiometer should be turned fully anti-clockwise to ensure that the control potentiometer is de-activated.

3.4.2 Operation using “Pot = Run” Jumper

With the “Pot = Run” jumper fitted, the control potentiometer provides the ON/OFF command source.

In order to provide the unit with a Run command the Control Potentiometer must be turned in a clockwise direction. To switch the unit OFF, turn the Control Potentiometer fully anti-clockwise (OFF position).



WARNING

If the unit is powered up when the Control Potentiometer is not in the OFF position, the unit may automatically restart and ramp-up to the frequency setpoint (Auto-restart function is active by default).

FREQUENCY SETPOINT

Setpoint addition: Control potentiometer and Analog input (P1000 = 27).

In order to provide the unit with a Frequency Setpoint the user can either:

1. Turn the control potentiometer.
2. Fit an external potentiometer, or apply an external analog control voltage across the terminals 6 and 7 AIN.

NOTE

1. The ‘Internal’ frequency setpoint set by the Control Potentiometer is ADDED to the external frequency setpoint (set by either external potentiometer or control voltage).
 2. On mains break or fault, the inverter will automatically re-start on power-up (Auto restart P1210 = 6 – default).
-

3.4.3 Non - Default Modes of Operation

Non-default modes of operation require the use of either a Keypad (BOP or AOP) or a Commissioning tool (Drive Monitor or Starter) in order to change from the default parameter settings.

The BOP, Part Number: 6SE6400-0BP00-0AA0 is housed in an Operator Panel Mounting Kit, Part Number 6SE6401-1DF00-0AA0 and connected via the Interface Link Cable, Part Number 6SE6401-1BL00-0AA0 to the Inverter serial comms port. This arrangement is shown in Figure 3-9.

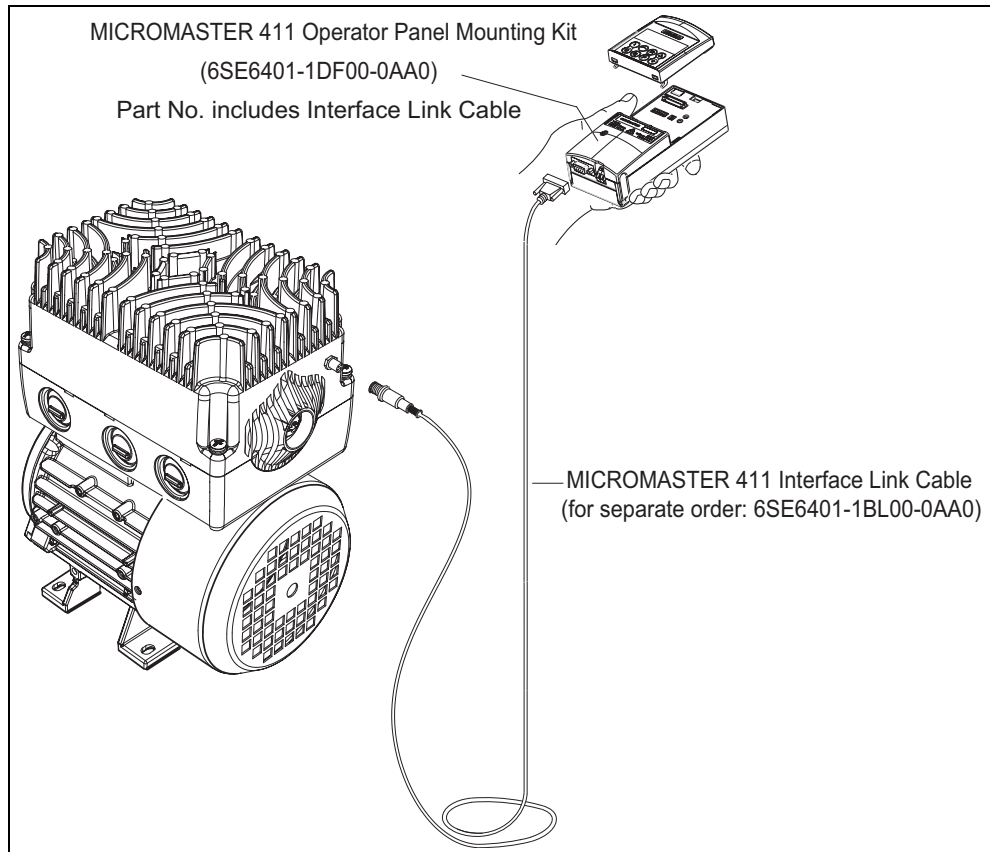







Figure 3-9 Connect BOP/AOP with the MICROMASTER 411

Prerequisites

- P0010 = 0 (in order to initiate the run command correctly).
 - P0700 = 1 (enables the start/stop button on the BOP).
 - P1000 = 1 (this enables the motor potentiometer setpoints).
-

1. Press the green Button  to start the motor.
2. Press the Button  while the motor is turning. Motor speed increases to 50 Hz.
3. When the inverter reaches 50 Hz, press the Button . Motor speed and display is decreased.
4. Change the direction of rotation with the Button .
5. The red button stops the motor .

Stopping the Motor

When the inverter is being operated using the Run/Stop switch (connected to DIN1) setting the switch to OFF will override the potentiometer setting and bring the motor to a controlled stop.

3.4.4 If the Motor does not start up

Refer to Chapter 6.

3.4.5 If a fault occurs

1. Switch off the Inverter.
2. Disconnect and reconnect the power supply.
3. Switch on again.
4. Faults are acknowledged by using digital input DIN 3 (default setting).
Switch off if the fault condition persists. Contact service department.

4 Using the MICROMASTER 411 / COMBIMASTER 411

This Chapter contains

- An explanation of the various methods of controlling the inverter
- A summary of the types of control of the inverter

4.1	Frequency Setpoint (P1000).....	68
4.2	Command Sources (P0700).....	69
4.3	OFF and Braking Functions.....	70
4.3.1	OFF1.....	70
4.3.2	OFF2.....	70
4.3.3	OFF3.....	70
4.3.4	DC Braking.....	71
4.3.5	COMPOUND Braking.....	71
4.4	Control Modes (P1300).....	72
4.5	Faults and warnings.....	73



WARNING

- When operating electrical devices, it is impossible to avoid applying hazardous voltages to certain parts of the equipment.
 - Emergency Stop facilities according to EN 60204 IEC 204 (VDE 0113) must remain functional in all operating modes of the control equipment. Any disengagement of the Emergency Stop facility must not lead to uncontrolled or undefined restarts.
 - Faults occurring in the control equipment can lead to substantial material damage, or even grievous bodily injury (i.e. potentially dangerous faults). Additional external precautions must be taken, or facilities provided, to ensure safe operation, (e.g. independent limit switches, mechanical interlocks, etc.).
 - COMBIMASTER 411/MICROMASTER 411 operate at high voltages.
 - Certain parameter settings may cause the inverter to restart automatically after an input power failure.
 - Motor parameters must be accurately configured for motor overload protection to operate correctly.
 - This equipment is capable of providing internal motor overload protection in accordance with UL508C. Refer to P0610 and P0335. i2t is ON by default. Motor overload protection can also be provided using an external PTC.
 - This equipment is suitable for use in a circuit capable of delivering not more than 10,000 symmetrical amperes (rms), for a maximum voltage of 460 V when protected by an H, J or K type fuse, a circuit breaker or self-protected combination motor controller.
 - This equipment must not be used as an 'Emergency Stop mechanism' (see EN 60204, 9.2.5.4)
-

4.1 Frequency Setpoint (P1000)

- Default: Setpoint Addition: Terminal 6/7 (AIN+/ AIN -)/Control Potentiometer
- Options see P1000

NOTE

For frequency setpoint via PROFIBUS see PROFIBUS Instructions.

4.2 Command Sources (P0700)

NOTICE

The **ramp times** and **ramp-smoothing functions** also affect how the motor starts and stops. For details of these functions, please refer to parameters P1120, P1121, P1130 – P1134 in the Parameter List.

Starting the motor

- Default Terminal 1 (DIN 1): (P0700=2)
- Other Settings see P0700 to P0704

Stopping the motor

There are several ways to stop the motor:

- Default:
 - OFF1 (4.3.1) Terminal 1 (DIN 1): (P0700=2)
 - OFF2 (4.3.2) Off button on BOP/AOP. Pressing the Off button once (two seconds) or twice (with default settings). This is not possible without BOP/AOP
 - OFF3 (4.3.3) no standard setting
- Other Settings see P0700 to P0704

Reversing the motor

- Default Terminal 2 (DIN 2)
- Other Settings see P0700 to P0704

4.3 OFF and Braking Functions

4.3.1 OFF1

This command (produced by canceling the ON command) causes the inverter to come to a standstill at the selected ramp-down rate.

Parameter to change ramp time see P1121.

NOTICE

- ON and the following OFF1 command must have the same source.
 - If the ON/OFF1 Command is set to more than one Digital input, only the last set Digital Input is active e.g. DIN3 active.
 - OFF1 can be combined with DC braking or COMPOUND braking.
-

4.3.2 OFF2

This command causes the motor to coast to a standstill.

NOTICE

The OFF2 command can have one or more sources. By default the OFF2 command is set to BOP/AOP. This source still exists even if other sources are defined by one of the following parameters, P0700, P0701, P0702, P0703 and P0704.

4.3.3 OFF3

An OFF3 command causes the motor to decelerate rapidly.

For starting the motor when OFF3 is set, the binary input has to be closed (high). If OFF3 is high, the motor can be started and stopped by ON/OFF1 or ON/OFF2.

The motor cannot be started, if OFF3 is open

Ramp down time: see P1135

NOTICE

OFF3 can be combined with DC braking or COMPOUND braking.

4.3.4 DC Braking

DC braking is possible together with OFF1 and OFF3. A DC current is applied to stop the motor quickly.

- set DC braking: see P0701 to P0704
- set braking period: see P1233
- set braking current: see P1232

NOTICE

If no digital input is set to DC braking and P1233 \neq 0, DC braking will be active after every OFF1 command.

4.3.5 COMPOUND Braking

COMPOUND Braking is possible with both OFF1 and OFF3. For COMPOUND Braking a DC component is added to the AC current.

Set the braking current: see P1236.

4.4 Control Modes (P1300)

The various modes of operation of the MICROMASTER 411 control the relationship between the speed of the motor and the voltage supplied by the inverter. A summary of the control modes available are listed below:

- **Linear V/f control** **P1300 = 0**
 Can be used for variable and constant torque applications, such as conveyors and positive displacement pumps.
- **Linear V/f control with FCC (Flux Current Control)** **P1300 = 1**
 This control mode can be used to improve the efficiency and dynamic response of the motor.
- **Quadratic V/f control** **P1300 = 2**
 This mode can be used for variable torque loads, such as fans and pumps.
- **Multi-point V/f control** **P1300 = 3**
 Multi-point V/f allows the user to define their own V/f Characteristics.
 This characteristic uses two fixed coordinates and three pairs of variable coordinates.
 Fixed co-ordinates are: Boost as defined in P1310 at 0 Hz.
 Nominal voltage P0304 at nominal frequency P0310
 Variable co-ordinates may be obtained from the following three pairs of coordinates
 P1320 (frequency) -P1321 (voltage)
 P1322 (frequency) -P1323 (voltage)
 P1324 (frequency) -P1325 (voltage)
 User programmable V/f characteristics are often used to provide correct torque at correct frequency, which can be useful when using the Inverter with synchronous motors. See Parameter List for further detail.

4.5 Faults and warnings

LED Fault Indication

Fault states and warnings are indicated by the LED within the control potentiometer on the inverter, see section 6.1 for further information.

BOP fitted

If a BOP is fitted, the fault states (P0947) and warnings (P2110) are displayed should a fault condition occur. For further details, please refer to section 6.2.

AOP fitted

If the AOP is fitted, fault and warning codes are displayed on the LCD panel.

5 System Parameters

This Chapter contains:

- An overview of the parameter structure of the MICROMASTER 411 / COMBIMASTER 411
- A parameter list in short form

5.1	Introduction to System Parameters	76
5.1.1	Access Levels	76
5.2	Parameter Structure.....	77
5.3	Parameter List (short form).....	78

5.1 Introduction to System Parameters

Parameters can only be changed by using the Basic Operator Panel (BOP), the Advanced Operator Panel (AOP) or Serial Interface.

NOTE

- Full details of the COMBIMASTER 411 /MICROMASTER 411 Parameters can be found in the separate document “COMBIMASTER 411/MICROMASTER 411 – Parameter List”.
 - This document is included in the CD ROM delivered with the product.
-

Parameters may be changed and set (using the BOP) to adjust the desired properties of the inverter, such as ramp times, minimum and maximum frequencies etc. The parameter numbers selected and the setting of the parameter values are indicated on the optional five-digit LCD display.

- rxxxx indicates a display parameter, Pxxxx a setting parameter.
- P0010 initiates “Quick Commissioning”. Set P0010 to 1.
- The inverter will not run unless P0010 is set to 0 after it has been accessed. This function is automatically performed if P3900 > 0.
- P0004 acts as a filter, allowing access to parameters according to their functionality group.
- If an attempt is made to change a parameter that cannot be changed in this status, for example, cannot be changed whilst running or can only be changed in quick commissioning, then `-----` will be displayed.

Busy Message

In some cases - when changing parameter values - the display on the BOP shows `busy` for maximum of five seconds. This means the inverter is busy with tasks of higher priority.

5.1.1 Access Levels

There are three access levels available to the user; Standard, Extended and Expert. The level of access is set by parameter P0003. For most applications, the Standard and Extended levels are sufficient.

The number of parameters that appear within each functional group depends on the access level set in parameter P0003. For further details regarding parameters, see the Parameter List on the Documentation CD-ROM.

5.2 Parameter Structure

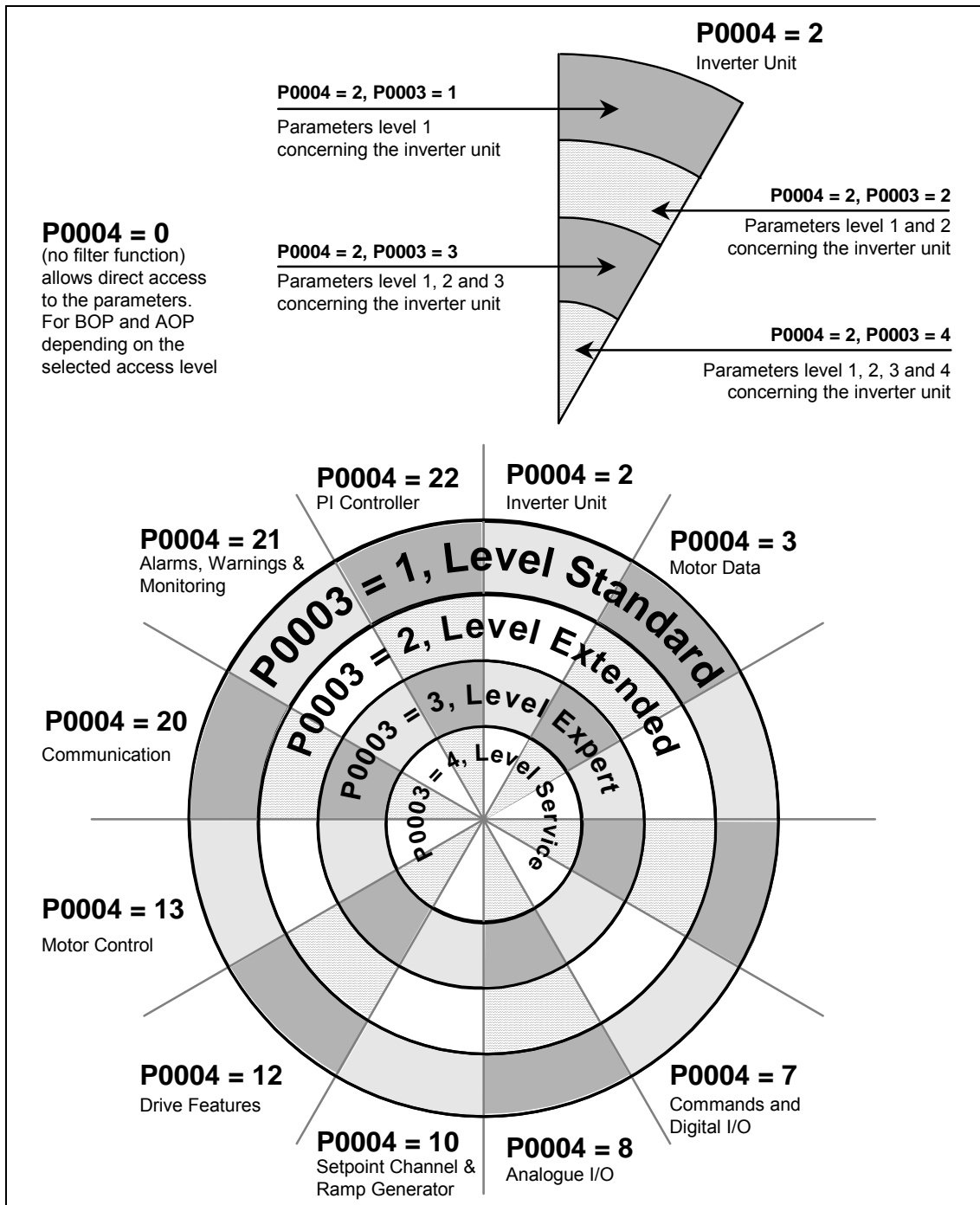

Figure 5-1 Parameter Structure with Filter (P0004)

5.3 Parameter List (short form)

Explanatory information on following table:

Default: Factory setting

Level: Access level

- DS
Inverter status (Drive State), indicates the inverter state in which a parameter can be modified (see P0010).
 - C Commissioning
 - U Run
 - T Ready to run
- QC
Quick Commissioning
 - Q Parameter can be modified in the Quick Commissioning state.
 - N Parameter cannot be modified in the Quick Commissioning state.

Always

ParNr	ParText	Default	Acc	WS	QC
r0000	Drive display	-	1	-	-
P0003	User access level	1	1	CUT	N
P0004	Parameter filter	0	1	CUT	N
P0010	Commissioning parameter	0	1	CT	N
P0014[3]	Store mode	0	3	UT	N
P0199	Equipment system number	0	2	UT	N

Quick Commissioning

ParNr	ParText	Default	Acc	WS	QC
P0100	Europe / North America	0	1	C	Q
P3900	End of quick commissioning	0	1	C	Q

Parameter reset

ParNr	ParText	Default	Acc	WS	QC
P0970	Factory reset	0	1	C	N

Inverter Unit (P0004 = 2)

ParNr	ParText	Default	Acc	WS	QC
r0018	Firmware version	-	1	-	-
r0026[1]	CO: Act. filtered DC-link volt.	-	2	-	-

ParNr	ParText	Default	Acc	WS	QC
r0037[1]	CO: Inverter temperature [°C]	-	3	-	-
r0039	CO: Energy consumpt. meter [kWh]	-	2	-	-
P0040	Reset energy consumption meter	0	2	CT	N
r0200	Act. power stack code number	-	3	-	-
P0201	Power stack code number	0	3	C	N
r0203	Act. inverter type	-	3	-	-
r0204	Power stack features	-	3	-	-
r0206	Rated inverter power [kW] / [hp]	-	2	-	-
r0207	Rated inverter current	-	2	-	-
r0208	Rated inverter voltage	-	2	-	-
r0209	Maximum inverter current	-	2	-	-
P0210	Supply voltage	230	3	CT	N
P0290	Inverter overload reaction	2	3	CT	N
P0292	Inverter overload warning	5	3	CUT	N
P1800	Pulse frequency	4	2	CUT	N
r1801	CO: Act. pulse frequency	-	3	-	-
P1802	Modulator mode	0	3	CUT	N
P1820[1]	Reverse output phase sequence	0	2	CT	N

Motor data (P0004 = 3)

ParNr	ParText	Default	Acc	WS	QC
r0034[1]	CO: Motor temperature (i2t)	-	2	-	-
P0300[1]	Select motor type	1	2	C	Q
P0304[1]	Rated motor voltage	230	1	C	Q
P0305[1]	Rated motor current	3.25	1	C	Q
P0307[1]	Rated motor power	0.75	1	C	Q
P0308[1]	Rated motor cosPhi	0.000	2	C	Q
P0309[1]	Rated motor efficiency	0.0	2	C	Q
P0310[1]	Rated motor frequency	50.00	1	C	Q
P0311[1]	Rated motor speed	0	1	C	Q
r0313[1]	Motor pole pairs	-	3	-	-
P0320[1]	Motor magnetizing current	0.0	3	CT	Q
r0330[1]	Rated motor slip	-	3	-	-
r0331[1]	Rated magnetization current	-	3	-	-
r0332[1]	Rated power factor	-	3	-	-
P0335[1]	Motor cooling	0	2	CT	Q
P0340[1]	Calculation of motor parameters	0	2	CT	N
P0344[1]	Motor weight	9.4	3	CUT	N
P0346[1]	Magnetization time	1.000	3	CUT	N
P0347[1]	Demagnetization time	1.000	3	CUT	N
P0350[1]	Stator resistance (line-to-line)	4.00000	2	CUT	N
r0384[1]	Rotor time constant	-	3	-	-

ParNr	ParText	Default	Acc	WS	QC
r0395	CO: Total stator resistance [%]	-	3	-	-
P0399	Motor mirror mode	2	3	CT	N
P0610[1]	Motor I2t temperature reaction	2	3	CT	N
P0611[1]	Motor I2t time constant	100	2	CT	N
P0614[1]	Motor I2t overload warning level	100.0	2	CUT	N
P0640[1]	Motor overload factor [%]	150.0	2	CUT	Q
P1910	Select motor data identification	0	2	CT	Q
r1912[1]	Identified stator resistance	-	2	-	-

Command and Digital I/O (P0004 = 7)

ParNr	ParText	Default	Acc	WS	QC
r0002	Drive state	-	2	-	-
r0019	CO/BO: BOP control word	-	3	-	-
r0052	CO/BO: Act. status word 1	-	2	-	-
r0053	CO/BO: Act. status word 2	-	2	-	-
r0054	CO/BO: Act. control word 1	-	3	-	-
r0055	CO/BO: Act. control word 2	-	3	-	-
P0700[1]	Selection of command source	2	1	CT	Q
P0701[1]	Function of digital input 1	1	2	CT	N
P0702[1]	Function of digital input 2	12	2	CT	N
P0703[1]	Function of digital input 3	9	2	CT	N
P0704[1]	Function of digital input 4	0	2	CT	N
P0705[1]	Function of digital input 5	0	2	CT	N
r0720	Number of digital inputs	-	3	-	-
P0719[2]	Selection of cmd. & freq. setp.	0	3	CT	N
r0722	CO/BO: Binary input values	-	2	-	-
P0724	Debounce time for digital inputs	3	3	CT	N
r0730	Number of digital outputs	-	3	-	-
P0731[1]	BI: Function of digital output 1	52:3	2	CUT	N
r0747	CO/BO: State of digital outputs	-	3	-	-
P0748	Invert digital outputs	0	3	CUT	N
P0800[1]	BI: Download parameter set 0	0:0	3	CT	N
P0801[1]	BI: Download parameter set 1	0:0	3	CT	N
P0810	BI: CDS bit 0 (Local / Remote)	0:0	2	CUT	N
P0840[1]	BI: ON/OFF1	722:0	3	CT	N
P0842[1]	BI: ON reverse/OFF1	0:0	3	CT	N
P0844[1]	BI: 1. OFF2	1:0	3	CT	N
P0845[1]	BI: 2. OFF2	19:1	3	CT	N
P0848[1]	BI: 1. OFF3	1:0	3	CT	N
P0849[1]	BI: 2. OFF3	1:0	3	CT	N
P0852[1]	BI: Pulse enable	1:0	3	CT	N
P1020[1]	BI: Fixed freq. selection Bit 0	0:0	3	CT	N

ParNr	ParText	Default	Acc	WS	QC
P1021[1]	Bl: Fixed freq. selection Bit 1	0:0	3	CT	N
P1022[1]	Bl: Fixed freq. selection Bit 2	0:0	3	CT	N
P1035[1]	Bl: Enable MOP (UP-command)	19:13	3	CT	N
P1036[1]	Bl: Enable MOP (DOWN-command)	19:14	3	CT	N
P1055[1]	Bl: Enable JOG right	0:0	3	CT	N
P1056[1]	Bl: Enable JOG left	0:0	3	CT	N
P1074[1]	Bl: Disable additional setpoint	0:0	3	CUT	N
P1110[1]	Bl: Inhibit neg. freq. setpoint	0:0	3	CT	N
P1113[1]	Bl: Reverse	722:1	3	CT	N
P1124[1]	Bl: Enable JOG ramp times	0:0	3	CT	N
P1140[1]	Bl: RFG enable	1:0	3	CT	N
P1141[1]	Bl: RFG start	1:0	3	CT	N
P1142[1]	Bl: RFG enable setpoint	1:0	3	CT	N
P1230[1]	Bl: Enable DC braking	0:0	3	CUT	N
P2103[1]	Bl: 1. Faults acknowledgement	722:2	3	CT	N
P2104[1]	Bl: 2. Faults acknowledgement	0:0	3	CT	N
P2106[1]	Bl: External fault	1:0	3	CT	N
P2220[1]	Bl: Fixed PID setp. select Bit 0	0:0	3	CT	N
P2221[1]	Bl: Fixed PID setp. select Bit 1	0:0	3	CT	N
P2222[1]	Bl: Fixed PID setp. select Bit 2	0:0	3	CT	N
P2235[1]	Bl: Enable PID-MOP (UP-cmd)	19:13	3	CT	N
P2236[1]	Bl: Enable PID-MOP (DOWN-cmd)	19:14	3	CT	N

Analogue I/O (P0004 = 8)

ParNr	ParText	Default	Acc	WS	QC
r0750	Number of ADCs	-	3	-	-
r0752[2]	Act. input of ADC [V]	-	2	-	-
P0753[1]	Smooth time ADC	3	3	CUT	N
r0754[2]	Act. ADC value after scaling [%]	-	2	-	-
r0755[2]	CO: Act. ADC after scal. [4000h]	-	2	-	-
P0756[1]	Type of ADC	0	2	CT	N
P0757[1]	Value x1 of ADC scaling [V]	0	2	CUT	N
P0758[1]	Value y1 of ADC scaling	0.0	2	CUT	N
P0759[1]	Value x2 of ADC scaling [V]	10	2	CUT	N
P0760[1]	Value y2 of ADC scaling	100.0	2	CUT	N
P0761[1]	Width of ADC deadband [V]	0	2	CUT	N
P0762[1]	Delay for loss of signal action	10	3	CUT	N

Setpoint Channel and Ramp Generator (P0004 = 10)

ParNr	ParText	Default	Acc	WS	QC
P1000[1]	Selection of frequency setpoint	27	1	CT	Q
P1001[1]	Fixed frequency 1	0.00	2	CUT	N
P1002[1]	Fixed frequency 2	5.00	2	CUT	N
P1003[1]	Fixed frequency 3	10.00	2	CUT	N
P1004[1]	Fixed frequency 4	15.00	2	CUT	N
P1005[1]	Fixed frequency 5	20.00	2	CUT	N
P1006[1]	Fixed frequency 6	25.00	2	CUT	N
P1007[1]	Fixed frequency 7	30.00	2	CUT	N
P1016	Fixed frequency mode – Bit 0	1	3	CT	N
P1017	Fixed frequency mode – Bit 1	1	3	CT	N
P1018	Fixed frequency mode – Bit 2	1	3	CT	N
r1024	CO: Act. fixed frequency	-	3	-	-
P1031[1]	Setpoint memory of the MOP	0	2	CUT	N
P1032	Inhibit reverse direction of MOP	1	2	CT	N
P1040[1]	Setpoint of the MOP	5.00	2	CUT	N
r1050	CO: Act. Output freq. of the MOP	-	3	-	-
P1058[1]	JOG frequency right	5.00	2	CUT	N
P1059[1]	JOG frequency left	5.00	2	CUT	N
P1060[1]	JOG ramp-up time	10.00	2	CUT	N
P1061[1]	JOG ramp-down time	10.00	2	CUT	N
P1070[1]	CI: Main setpoint	755:0	3	CT	N
P1071[1]	CI: Main setpoint scaling	1:0	3	CT	N
P1075[1]	CI: Additional setpoint	755:1	3	CT	N
P1076[1]	CI: Additional setpoint scaling	1:0	3	CT	N
r1078	CO: Total frequency setpoint	-	3	-	-
r1079	CO: Selected frequency setpoint	-	3	-	-
P1080[1]	Min. frequency	0.00	1	CUT	Q
P1082[1]	Max. frequency	50.00	1	CT	Q
P1091[1]	Skip frequency 1	0.00	3	CUT	N
P1092[1]	Skip frequency 2	0.00	3	CUT	N
P1093[1]	Skip frequency 3	0.00	3	CUT	N
P1094[1]	Skip frequency 4	0.00	3	CUT	N
P1101[1]	Skip frequency bandwidth	2.00	3	CUT	N
r1114	CO: Freq. setp. after dir. ctrl.	-	3	-	-
r1119	CO: Freq. setpoint before RFG	-	3	-	-
P1120[1]	Ramp-up time	10.00	1	CUT	Q
P1121[1]	Ramp-down time	10.00	1	CUT	Q
P1130[1]	Ramp-up initial rounding time	0.00	2	CUT	N
P1131[1]	Ramp-up final rounding time	0.00	2	CUT	N
P1132[1]	Ramp-down initial rounding time	0.00	2	CUT	N
P1133[1]	Ramp-down final rounding time	0.00	2	CUT	N

ParNr	ParText	Default	Acc	WS	QC
P1134[1]	Rounding type	0	2	CUT	N
P1135[1]	OFF3 ramp-down time	5.00	2	CUT	Q
r1170	CO: Frequency setpoint after RFG	-	3	-	-

Drive Features (P0004 = 12)

ParNr	ParText	Default	Acc	WS	QC
P0005[1]	Display selection	21	2	CUT	N
P0006	Display mode	2	3	CUT	N
P0007	Backlight delay time	0	3	CUT	N
P0011	Lock for user defined parameter	0	3	CUT	N
P0012	Key for user defined parameter	0	3	CUT	N
P0013[20]	User defined parameter	0	3	CUT	N
P1200	Flying start	0	2	CUT	N
P1202[1]	Motor-current: Flying start	100	3	CUT	N
P1203[1]	Search rate: Flying start	100	3	CUT	N
P1210	Automatic restart	1	2	CUT	N
P1211	Number of restart attempts	3	3	CUT	N
P1215	Holding brake enable	0	2	T	N
P1216	Holding brake release delay	1.0	2	T	N
P1217	Holding time after ramp down	1.0	2	T	N
P1232[1]	DC braking current	100	2	CUT	N
P1233[1]	Duration of DC braking	0	2	CUT	N
P1236[1]	Compound braking current	0	2	CUT	N
P1240[1]	Configuration of Vdc controller	1	3	CT	N
r1242	CO: Switch-on level of Vdc-max	-	3	-	-
P1243[1]	Dynamic factor of Vdc-max	100	3	CUT	N
P1253[1]	Vdc-controller output limitation	10.00	3	CUT	N
P1254	Auto detect Vdc switch-on levels	1	3	CT	N

Motor Control (P0004 = 13)

ParNr	ParText	Default	Acc	WS	QC
r0020	CO: Freq. setpoint before RFG	-	3	-	-
r0021	CO: Act. frequency	-	2	-	-
r0022	Act. filtered rotor speed	-	3	-	-
r0024	CO: Act. output frequency	-	3	-	-
r0025	CO: Act. output voltage	-	2	-	-
r0027	CO: Act. output current	-	2	-	-
r0056	CO/BO: Status of motor control	-	3	-	-
r0057	Jumper status	-	2	-	-
r0067	CO: Act. output current limit	-	3	-	-
r0071	CO: Max. output voltage	-	3	-	-

ParNr	ParText	Default	Acc	WS	QC
r0078	CO: Act. current Isq	-	3	-	-
r0086	CO: Act. active current	-	3	-	-
P1300[1]	Control mode	0	2	CT	Q
P1310[1]	Continuous boost	50.0	2	CUT	N
P1311[1]	Acceleration boost	0.0	2	CUT	N
P1312[1]	Starting boost	0.0	2	CUT	N
P1316[1]	Boost end frequency	20.0	3	CUT	N
P1320[1]	Programmable V/f freq. coord. 1	0.00	3	CT	N
P1321[1]	Programmable V/f volt. coord. 1	0.0	3	CUT	N
P1322[1]	Programmable V/f freq. coord. 2	0.00	3	CT	N
P1323[1]	Programmable V/f volt. coord. 2	0.0	3	CUT	N
P1324[1]	Programmable V/f freq. coord. 3	0.00	3	CT	N
P1325[1]	Programmable V/f volt. coord. 3	0.0	3	CUT	N
P1333[1]	Start frequency for FCC	10.0	3	CUT	N
P1335[1]	Slip compensation	0.0	2	CUT	N
P1336[1]	Slip limit	250	2	CUT	N
r1337	CO: V/f slip frequency	-	3	-	-
P1338[1]	Resonance damping gain V/f	0.00	3	CUT	N
P1340[1]	Imax controller prop. gain	0.000	3	CUT	N
P1341[1]	Imax controller integral time	0.300	3	CUT	N
r1343	CO: Imax controller freq. output	-	3	-	-
r1344	CO: Imax controller volt. output	-	3	-	-
P1350[1]	Voltage soft start	0	3	CUT	N

Communication (P0004 = 20)

ParNr	ParText	Default	Acc	WS	QC
P0918	CB address	3	2	CT	N
P0927	Parameter changeable via	15	2	CUT	N
r0965	Profibus profile	-	3	-	-
r0967	Control word 1	-	3	-	-
r0968	Status word 1	-	3	-	-
r0964[5]	Firmware version data	-	3	-	-
P0971	Transfer data from RAM to EEPROM	0	3	CUT	N
P2000[1]	Reference frequency	50.00	2	CT	N
P2001[1]	Reference voltage	1000	3	CT	N
P2002[1]	Reference current	0.10	3	CT	N
P2009[2]	USS normalization	0	3	CT	N
P2010[2]	USS baudrate	6	2	CUT	N
P2011[2]	USS address	0	2	CUT	N
P2012[2]	USS PZD length	2	3	CUT	N
P2013[2]	USS PKW length	127	3	CUT	N
P2014[2]	USS telegram off time	0	3	CT	N

ParNr	ParText	Default	Acc	WS	QC
r2015[4]	CO: PZD from BOP link (USS)	-	3	-	-
P2016[4]	CI: PZD to BOP link (USS)	52:0	3	CT	N
r2018[4]	CO: PZD from COM link (USS)	-	3	-	-
P2019[4]	CI: PZD to COM link (USS)	52:0	3	CT	N
r2024[2]	USS error-free telegrams	-	3	-	-
r2025[2]	USS rejected telegrams	-	3	-	-
r2026[2]	USS character frame error	-	3	-	-
r2027[2]	USS overrun error	-	3	-	-
r2028[2]	USS parity error	-	3	-	-
r2029[2]	USS start not identified	-	3	-	-
r2030[2]	USS BCC error	-	3	-	-
r2032	BO: CtrlWrd1 from BOP link (USS)	-	3	-	-
r2031[2]	USS length error	-	3	-	-
r2033	BO: CtrlWrd2 from BOP link (USS)	-	3	-	-
r2036	BO: CtrlWrd1 from COM link (USS)	-	3	-	-
r2037	BO: CtrlWrd2 from COM link (USS)	-	3	-	-
P2040	CB telegram off time	20	3	CT	N
P2041[5]	CB parameter	0	3	CT	N
r2050[4]	CO: PZD from CB	-	3	-	-
P2051[4]	CI: PZD to CB	52:0	3	CT	N
r2053[5]	CB identification	-	3	-	-
r2054[7]	CB diagnosis	-	3	-	-
r2090	BO: Control word 1 from CB	-	3	-	-
r2091	BO: Control word 2 from CB	-	3	-	-

Alarms and Warnings (P0004 = 21)

ParNr	ParText	Default	Acc	WS	QC
P0952	Total number of faults	0	3	CT	N
r0947[8]	Last fault code	-	2	-	-
r0949[8]	Fault value	-	3	-	-
r0948[12]	Fault time	-	3	-	-
P2100[3]	Alarm number selection	0	3	CT	N
P2101[3]	Stop reaction value	0	3	CT	N
P2111	Total number of warnings	0	3	CT	N
r2110[4]	Warning number	-	2	-	-
r2114[2]	Run time counter	-	3	-	-
P2150[1]	Hysteresis frequency f_hys	3.00	3	CUT	N
P2155[1]	Threshold frequency f_1	30.00	3	CUT	N
P2156[1]	Delay time of threshold freq f_1	10	3	CUT	N
P2164[1]	Hysteresis frequency deviation	3.00	3	CUT	N
P2167[1]	Switch-off frequency f_off	1.00	3	CUT	N
P2168[1]	Delay time T_off	10	3	CUT	N

ParNr	ParText	Default	Acc	WS	QC
P2170[1]	Threshold current I_thresh	100.0	3	CUT	N
P2171[1]	Delay time current	10	3	CUT	N
P2172[1]	Threshold DC-link voltage	800	3	CUT	N
P2173[1]	Delay time DC-link voltage	10	3	CUT	N
P2179	Current limit for no load ident.	3.0	3	CUT	N
P2180	Delay time for load missing	2000	3	CUT	N
r2197	CO/BO: Monitoring word 1	-	2	-	-

PI Controller (P0004=22)

ParNr	ParText	Default	Acc	WS	QC
P2200[1]	BI: Enable PID controller	0:0	2	CUT	N
P2201[1]	Fixed PID setpoint 1	0.00	2	CUT	N
P2202[1]	Fixed PID setpoint 2	10.00	2	CUT	N
P2203[1]	Fixed PID setpoint 3	20.00	2	CUT	N
P2204[1]	Fixed PID setpoint 4	30.00	2	CUT	N
P2205[1]	Fixed PID setpoint 5	40.00	2	CUT	N
P2206[1]	Fixed PID setpoint 6	50.00	2	CUT	N
P2207[1]	Fixed PID setpoint 7	60.00	2	CUT	N
P2216	Fixed PID setpoint mode - Bit 0	1	3	CT	N
P2217	Fixed PID setpoint mode - Bit 1	1	3	CT	N
P2218	Fixed PID setpoint mode - Bit 2	1	3	CT	N
r2224	CO: Act. fixed PID setpoint	-	2	-	-
P2231[1]	Setpoint memory of PID-MOP	0	2	CUT	N
P2232	Inhibit rev. direct. of PID-MOP	1	2	CT	N
P2240[1]	Setpoint of PID-MOP	10.00	2	CUT	N
r2250	CO: Output setpoint of PID-MOP	-	2	-	-
P2253[1]	CI: PID setpoint	0:0	2	CUT	N
P2254[1]	CI: PID trim source	0:0	3	CUT	N
P2255	PID setpoint gain factor	100.00	3	CUT	N
P2256	PID trim gain factor	100.00	3	CUT	N
P2257	Ramp-up time for PID setpoint	1.00	2	CUT	N
P2258	Ramp-down time for PID setpoint	1.00	2	CUT	N
r2260	CO: PID setpoint after PID-RFG	-	2	-	-
P2261	PID setpoint filter timeconstant	0.00	3	CUT	N
r2262	CO: Filtered PID setp. after RFG	-	3	-	-
P2264[1]	CI: PID feedback	755:0	2	CUT	N
P2265	PID feedback filter timeconstant	0.00	2	CUT	N
r2266	CO: PID filtered feedback	-	2	-	-
P2267	Max. value for PID feedback	100.00	3	CUT	N
P2268	Min. value for PID feedback	0.00	3	CUT	N
P2269	Gain applied to PID feedback	100.00	3	CUT	N
P2270	PID feedback function selector	0	3	CUT	N

ParNr	ParText	Default	Acc	WS	QC
P2271	PID transducer type	0	2	CUT	N
r2272	CO: PID scaled feedback	-	2	-	-
r2273	CO: PID error	-	2	-	-
P2280	PID proportional gain	3.000	2	CUT	N
P2285	PID integral time	0.000	2	CUT	N
P2291	PID output upper limit	100.00	2	CUT	N
P2292	PID output lower limit	0.00	2	CUT	N
P2293	Ramp-up /-down time of PID limit	1.00	3	CUT	N
r2294	CO: Act. PID output	-	2	-	-
P2390	Energy saving setpoint	0	3	CUT	N
P2391	Energy saving timer	0	3	CT	N
P2392	Energy saving restart setpoint	0	3	CT	N
P2393	EnerSav changeover threshold	90.0	3	CUT	N
P2394	Energy saving low characteristic	0.00	3	CUT	N
P2395	Energy saving up characteristic	0.00	3	CUT	N
P2396[1]	CI: Torque	86:0	2	CUT	N
P2397	Torque filtered timeconstant	0.00	2	CUT	N
r2398	CO: Filtered torque		2	-	-
r2399	CO/BO: Energy Saving status word		3	-	-

6 Troubleshooting

This Chapter contains:

- An overview of the operating statuses of the inverter with LED
- Notes on troubleshooting with the BOP
- A list of the alarms and fault messages

6.1	Troubleshooting with the Inverter LED	90
6.2	Troubleshooting with the Basic Operator Panel	90
6.3	Faults and Alarms	91
6.3.1	Fault messages.....	91
6.3.2	Alarm Messages	96



WARNING

- Repairs on equipment may only be carried out by **Siemens Service**, by repair centers **authorized by Siemens** or by qualified personnel who are thoroughly acquainted with all the warnings and operating procedures contained in this manual.
 - Any defective parts or components must be replaced using parts contained in the relevant spare parts list.
 - Disconnect the power supply before opening the equipment for access.
-

6.1 Troubleshooting with the Inverter LED

Check the status of the LED located within the control potentiometer.

A list of the LED status indications are given in the following table .

Table 6-1 Inverter LED Indication

Condition	Status
200 ms on / 800 ms off	Power On / Ready
Continuous on	Running
800 ms on / 200 ms off	Warning (general)
500 ms on / 500 ms off	Trip (general)
OFF	Off/Mains supply fault / No inverter power

6.2 Troubleshooting with the Basic Operator Panel

Warnings and faults are displayed on the BOP with Axxx and Fxxx respectively.

If the motor fails to start when the ON command has been given:

- Check that P0010 = 0.
- Check that a valid ON signal is present.
- Check that P0700 = 2 (for Terminal I/O control) or P0700 = 1 (for BOP control).
- Check that the setpoint is present (0 to 10 V on Terminal 7) or the setpoint has been entered into the correct parameter, depending upon the setpoint source (P1000). For further details see the Parameter List.

If the motor fails to run after changing the parameters, set P0010 = 30 then P0970 = 1 and press P to reset the inverter to the factory default parameter values.

By using a switch between terminals 1 and 4 on the I/O board, the drive should now run to the defined setpoint (established by analog input and/or control potentiometer).

NOTICE

For the MICROMASTER 411 the motor data must relate to the inverter data power range and voltage.

6.3 Faults and Alarms

In the event of a failure, the inverter switches off and a fault code appears on the display.

NOTE

To reset the fault code, one of three methods listed below can be used:

Method 1: Cycle the power to the drive

Method 2: Press the  button on the BOP or AOP

Method 3: Via Digital Input 3 (Default Setting)

6.3.1 Fault messages

Fault messages are stored in parameter r0947 under their code number (e.g. F0003 = 3). The associated error value is found in parameter r0949. The value 0 is entered if a fault has no error value. It is furthermore possible to read out the point in time that a fault occurred (r0948) and the number of fault messages (P0952) stored in Parameter r0947.

F0001 OverCurrent

OFF2

Possible Causes

- Motor power (P0307) does not correspond to the inverter power (r0206)
- Motor leads are too long
- Motor lead short circuit
- Earth faults

Diagnose & Remedy

Check the following:

- Motor power (P0307) must correspond to inverter power (r0206)
- Cable length limits must not be exceeded
- Motor cable and motor must have no short-circuits or earth faults
- Motor parameters must match the motor in use
- Value of stator resistance (P0350) must be correct
- Motor must not be obstructed or overloaded
- Increase the ramp time
- Reduce the boost level (V/f control: P1311 & P1312, Vector control: P1610 & P1611)

F0002 OverVoltage

OFF2

Possible Causes

- DC-link controller disabled (P1240 = 0)
- DC-link voltage (r0026) exceeds trip level (P2172)
- Overvoltage can be caused either by too high main supply voltage or if motor is in regenerative mode. Regenerative mode can be caused by fast ramp downs or if the motor is driven from an active load.

Diagnose & Remedy

Check the following:

- Supply voltage (P0210) must lie within limits indicated on rating plate
- DC-link voltage controller must be enabled (P1240) and parameterized properly
- Ramp-down time (P1121) must match inertia of load
- Required braking power must lie within specified limits

NOTE

Higher inertia requires longer ramp times; otherwise, apply braking resistor.

F0003 UnderVoltage**OFF2****Possible Causes**

- Main supply failed
- Shock load outside specified limits

Diagnose & Remedy

Check the following:

- Supply voltage (P0210) must lie within limits indicated on rating plate
- Supply must not be susceptible to temporary failures or voltage reductions
- Enable kinetic buffering (P1240 = 2)

F0004 Inverter Over Temperature**OFF2****Possible Causes**

- Ventilation inadequate
- Ambient temperature is too high

Diagnose & Remedy

Check the following:

- Load conditions and duty cycle must be appropriate
- Fan must turn when inverter is running
- Pulse frequency (P1800) must be set to default value
- Ambient temperature could be higher than specified for the inverter

F0005 Inverter I²t**OFF2****Possible Causes**

- Inverter overloaded
- Duty cycle too demanding
- Motor power (P0307) exceeds inverter power capability (r0206)

Diagnose & Remedy

Check the following:

- Load duty cycle must lie within specified limits
- Motor power (P0307) must match inverter power (r0206)

F0011 Motor Over Temperature**OFF1****Possible Causes**

Motor overloaded

Diagnose & Remedy

Check the following:

- Load duty cycle must be correct
- Motor nominal overtemperatures (P0626-P0628) must be correct
- Motor temperature warning level (P0604) must match

F0012 Inverter temp. signal lost**OFF2****Possible Causes**

Wire breakage of inverter temperature (heatsink) sensor

F0022 Powerstack fault OFF2**Possible Causes**

That hardware fault (r0947 = 22 and r0949 = 1) caused by the following events:

- (1) DC-link overcurrent = short circuit of IGBT
- (2) Short circuit of chopper
- (3) Earth fault
- (4) I/O board is not properly inserted

Diagnose & Remedy

Check the I/O board. It has to be fully pressed home.

F0023 Output fault OFF2**Possible Causes**

One motor phase is disconnected

F0035 Auto restart after n OFF2**Possible Causes**

Auto restart attempts exceed value of P1211

F0041 Motor Data Identification Failure OFF2**Possible Causes**

Motor data identification failed.

Fault value = 0: Load missing

- 1: Current limit level reached during identification.
- 2: Identified stator resistance less than 0.1 % or greater than 100 %.
- 3: Identified rotor resistance less than 0.1 % or greater than 100 %.
- 4: Identified stator reactance less than 50 % and greater than 500 %
- 5: Identified main reactance less than 50 % and greater than 500 %
- 6: Identified rotor time constant less than 10 ms or greater than 5 s
- 7: Identified total leakage reactance less than 5 % and greater than 50 %
- 8: Identified stator leakage reactance less than 25 % and greater than 250 %
- 9: Identified rotor leakage inductance less than 25 % and greater than 250 %
- 20: Identified IGBT on-voltage less than 0.5 V or greater than 10 V
- 30: Current controller at voltage limit
- 40: Inconsistency of identified data set, at least one identification failed

Percentage values based on the impedance $Z_b = V_{mot,nom} / \sqrt{3} / I_{mot,nom}$

Diagnose & Remedy

- Fault value = 0: Check that the motor is connected to the inverter
 - Fault value = 1-40: Check if motor data in P0304 to P0311 are correct
- Check what type of motor wiring is required (star, delta).

F0051 Parameter EEPROM Fault OFF2**Possible Causes**

Read or write failure while saving non-volatile parameter

Diagnose & Remedy

- Factory Reset and new parameterization
- Contact Customer Support / Service Department

F0052 Power stack Fault OFF2**Possible Causes**

Read failure for power stack information or invalid data

Diagnose & Remedy

Hardware defect, contact Customer Support / Service Department

F0053	IO EEPROM Fault	OFF2
	Possible Causes Read failure for IO EEPROM information or invalid data	
	Diagnose & Remedy <ul style="list-style-type: none">➤ Check data➤ Change IO board	
F0054	Wrong IO Board	OFF2
	Possible Causes <ul style="list-style-type: none">➤ Wrong IO board is connected➤ No ID detected on IO board, no data	
	Diagnose & Remedy <ul style="list-style-type: none">➤ Check data➤ Change IO board	
F0060	Asic Timeout	OFF2
	Possible Causes Internal communications failure	
	Diagnose & Remedy <ul style="list-style-type: none">➤ If fault persists, change inverter➤ Contact Service Department	
F0070	CB setpoint fault	OFF2
	Possible Causes No setpoint values from CB (communication board) during telegram off time	
	Diagnose & Remedy Check CB and communication partner	
F0071	USS (BOP-link) setpoint fault	OFF2
	Possible Causes No setpoint values from USS during telegram off time	
	Diagnose & Remedy Check USS master	
F0072	USS (COMM link) setpoint fault	OFF2
	Possible Causes No setpoint values from USS during telegram off time	
	Diagnose & Remedy Check USS master	
F0080	ADC lost input signal	OFF2
	Possible Causes <ul style="list-style-type: none">➤ Broken wire➤ Signal out of limits	

F0085	External Fault	OFF2
	<p>Possible Causes External fault triggered via for example terminal inputs</p> <p>Diagnose & Remedy Disable for example terminal input for fault trigger</p>	
F0101	Stack Overflow	OFF2
	<p>Possible Causes Software error or processor failure</p> <p>Diagnose & Remedy Run self test routines</p>	
F0221	PID Feedback below min. value	OFF2
	<p>Possible Causes PID Feedback below min. value P2268</p> <p>Diagnose & Remedy</p> <ul style="list-style-type: none"> ➤ Change value of P2268 ➤ Adjust feedback gain 	
F0222	PID Feedback above max. value	OFF2
	<p>Possible Causes PID feedback above max. value P2267</p> <p>Diagnose & Remedy</p> <ul style="list-style-type: none"> ➤ Change value of P2267 ➤ Adjust feedback gain 	
F0450	BIST Tests Failure	OFF2
	<p>Possible Causes</p> <p>Fault value = 1: Some power section tests have failed 2: Some control board tests have failed 4: Some functional tests have failed 8: Some IO board tests have failed (MM 420 only) 16: Internal RAM failed on power-up check</p> <p>Diagnose & Remedy Hardware defect, contact Customer Support / Service Department</p>	

F0452 Belt Failure Detected**OFF2****Possible Causes**

Load conditions on motor indicate belt failure or mechanical fault.

Diagnose & Remedy

Check the following:

- No breakage, seizure or obstruction of drive train.
- If using an external speed sensor, check for correct function. Check parameters: P2192 (delay time for permitted deviation)
- If using the torque envelope, check parameters:
 - P2182 (threshold frequency f1)
 - P2183 (threshold frequency f2)
 - P2184 (threshold frequency f3)
 - P2185 (upper torque threshold 1)
 - P2186 (lower torque threshold 1)
 - P2187 (upper torque threshold 2)
 - P2188 (lower torque threshold 2)
 - P2189 (upper torque threshold 3)
 - P2190 (lower torque threshold 3)
 - P2192 (delay time for permitted deviation)

6.3.2 Alarm Messages

Alarm messages are stored in parameter r2110 under their code number (e.g. A0503 = 503) and can be read out from there.

A0501 Current Limit**Possible Causes**

- Motor power (P0307) does not correspond to the inverter power (P0206)
- Motor leads are too long
- Earth faults

Diagnose & Remedy

Check the following:

- Motor power (P0307) must correspond to inverter power (r0206)
- Cable length limits must not be exceeded
- Motor cable and motor must have no short-circuits or earth faults
- Motor parameters must match the motor in use
- Value of stator resistance (P0350) must be correct
- Motor must not be obstructed or overloaded
- Increase the ramp-up-time.
- Reduce the boost level (V/f control: P1311 & P1312, Vector control: P1610 & P1611)

A0502 Overvoltage limit**Possible Causes**

- Overvoltage limit is reached
- This warning can occur during ramp down, if the dc-link controller is disabled (P1240 = 0)

Diagnose & Remedy

Check the following:

- Supply voltage (P0210) must lie within limits indicated on rating plate
- DC-link voltage controller must be enabled (P1240) and parameterized properly
- Ramp-down time (P1121) must match inertia of load
- Required braking power must lie within specified limits

A0503 UnderVoltage Limit

Possible Causes

- Main supply failed
- Main supply (P0210) and consequently DC-link voltage (r0026) below specified limit (P2172)

Diagnose & Remedy

- Supply voltage (P0210) must lie within limits indicated on rating plate
- Supply must not be susceptible to temporary failures or voltage reductions
- Enable kinetic buffering (P1240 = 2)

A0504 Inverter OverTemperature

Possible Causes

Warning level of inverter heat-sink temperature (P0614) is exceeded, resulting in pulse frequency reduction and/or output frequency reduction (depending on parameterization in P0610)

Diagnose & Remedy

Check the following:

- Load conditions and duty cycle must be appropriate
- Fan must turn when inverter is running
- Pulse frequency (P1800) must be set to default value
- Ambient temperature could be higher than specified for the inverter

A0505 Inverter I²t

Possible Causes

Warning level (P0294) exceeded, output frequency and/or pulse frequency will be reduced if parameterized (P0290)

Diagnose & Remedy

Check the following:

- Load duty cycle must lie within specified limits
- Motor power (P0307) must match inverter power (r0206)

A0511 Motor OverTemperature

Possible Causes

- Motor overloaded
- Load duty cycle too high

Diagnose & Remedy

Independently of the kind of temperature determination check the following:

- Load duty cycle must be correct
- Motor nominal overtemperatures (P0626-P0628) must be correct
- Motor temperature warning level (P0604) must match

A0522 I2C read out timeout

Possible Causes

The cyclic access to the UCE Values and powerstack temperatures via the I2C bus (MM440 Frame size FX & GX) is disturbed

A0523 Output fault

Possible Causes

One motor phase is disconnected

A0535 Braking Resistor Hot

Diagnose & Remedy

- Increase duty cycle P1237
- Increase ramp down time P1121

A0541 Motor Data Identification Active**Possible Causes**

Motor data identification (P1910) selected or running

A0542 Speed Control Optimisation Active**Possible Causes**

Speed Control Optimisation (P1960) is selected or running

- Check encoder not faulty (select P1300 = 0, run at fixed speed, check encoder feedback signal in r0061)
- Increase encoder loss threshold in P0492

A0600 RTOS Overrun Warning**A0700 CB warning 1****Possible Causes**

CB (communication board) specific

Diagnose & Remedy

See CB user manual

A0701 CB warning 2**Possible Causes**

CB (communication board) specific

Diagnose & Remedy

See CB user manual

A0702 CB warning 3**Possible Causes**

CB (communication board) specific

Diagnose & Remedy

See CB user manual

A0703 CB warning 4**Possible Causes**

CB (communication board) specific

Diagnose & Remedy

See CB user manual

A0704 CB warning 5**Possible Causes**

CB (communication board) specific

Diagnose & Remedy

See CB user manual

A0705 CB warning 6**Possible Causes**

CB (communication board) specific

Diagnose & Remedy

See CB user manual

A0706 CB warning 7**Possible Causes**

CB (communication board) specific

Diagnose & Remedy

See CB user manual

A0707 CB warning 8**Possible Causes**

CB (communication board) specific

Diagnose & Remedy

See CB user manual

A0708 CB warning 9**Possible Causes**

CB (communication board) specific

Diagnose & Remedy

See CB user manual

A0709 CB warning 10**Possible Causes**

CB (communication board) specific

Diagnose & Remedy

See CB user manual

A0710 CB communication error**Possible Causes**

Communication with CB (communication board) is lost

Diagnose & Remedy

Check CB hardware

A0711 CB configuration error**Possible Causes**

CB (communication board) reports a configuration error.

Diagnose & Remedy

Check CB parameters

A0910 Vdc-max controller de-activated**Possible Causes**

Vdc max controller has been de-activated, since controller is not capable of keeping DC-link voltage (r0026) within limits (P2172).

- Occurs if main supply voltage (P0210) is permanently too high
- Occurs if motor is driven by an active load, causing motor to go into regenerative mode
- Occurs at very high load inertias, when ramping down

Diagnose & Remedy

Check the following:

- Input voltage (P0210) must lie within range
- Load must be match

A0911 Vdc-max controller active**Possible Causes**

Vdc max controller is active; so ramp-down times will be increased automatically to keep DC-link voltage (r0026) within limits (P2172).

A0912 Vdc-min controller active**Possible Causes**

Vdc min controller will be activated if DC-link voltage (r0026) falls below minimum level (P2172). The kinetic energy of the motor is used to buffer the DC-link voltage, thus causing deceleration of the drive!
So short mains failures do not necessarily lead to an undervoltage trip.

A0920 ADC parameters not set properly**Possible Causes**

ADC parameters should not be set to identical values, since this would produce illogical results.

Fault value = 0: Parameter settings for output identical

- 1: Parameter settings for input identical
- 2: Parameter settings for input do not correspond to ADC type

A0921 DAC parameters not set properly**Possible Causes**

DAC parameters should not be set to identical values, since this would produce illogical results.

Fault value = 0: Parameter settings for output identical

- 1: Parameter settings for input identical
- 2: Parameter settings for output do not correspond to DAC type

A0922 No load applied to inverter**Possible Causes**

No Load is applied to the inverter.

As a result, some functions may not work as under normal load conditions.

A0923 Both JOG Left and JOG Right are requested**Possible Causes**

Both JOG right and JOG left (P1055/P1056) have been requested. This freezes the RFG output frequency at its current value.

A0936 PID Autotuning Active

Possible Causes

PID Autotuning (P2350) selected or running

A0952 Belt Failure Warning

Possible Causes

Load conditions on motor indicate belt failure or mechanical fault.

Diagnose & Remedy

Check the following:

- No breakage, seizure or obstruction of drive train.
- If using an external speed sensor, check for correct function. Check parameters:
 - P2192 (delay time for permitted deviation)
- If using the torque envelope, check parameters:
 - P2182 (threshold frequency f1)
 - P2183 (threshold frequency f2)
 - P2184 (threshold frequency f3)
 - P2185 (upper torque threshold 1)
 - P2186 (lower torque threshold 1)
 - P2187 (upper torque threshold 2)
 - P2188 (lower torque threshold 2)
 - P2189 (upper torque threshold 3)
 - P2190 (lower torque threshold 3)
 - P2192 (delay time for permitted deviation)

7 Specifications

This Chapter contains:

- The common technical data to the MICROMASTER 411 / COMBIMASTER 411 Inverters
- The wire sizes and terminal torques
- Divided into several tables - an overview of the specific technical data of every MICROMASTER 411 / COMBIMASTER 411 Inverter

7.1	General Data.....	104
7.2	Case Size Rating Information	105
7.3	Tightening Torque, Cable cross sections for Power Supply and Motor Terminals.....	106
7.4	Tightening Torque for Fixing Screws	106
7.5	Fuses and Circuit Breakers	107

7.1 General Data

Table 7-1 MICROMASTER 411 / COMBIMASTER 411, General Data

Feature	Specification
Power supply Operating Voltage & Power Ranges	380 to 480 V \pm 10% 3AC
Input Frequency	47 to 63 Hz
Cos phi	³ 0,95
Inverter Efficiency	94 % to 97 % at maximum power
Overload Capability	50 % overload capability for 60 s within 5 min referred to the nominal output current
Inrush Current	Less than 4 A for CSB and less than 7.7 A for CSC.
Control Method	Linear V/f; Flux Current Control (FCC); Quadratic V/f; Multi-point V/f.
Pulse Frequency	2 kHz to 16 kHz (2 kHz steps) 4 kHz default
Fixed Frequencies	7, programmable
Skip Frequencies	4, programmable
Setpoint Resolution	0.01 Hz Digital, 0.01 Hz Serial, 10 bit Analog
Output Frequency Resolution	0.01 Hz Digital, 0.01 Hz Serial, 10 bit Analog
Digital Inputs	3, programmable (isolated), switchable active high / active low (PNP/NPN)
Analogue Input	1, for target value or PI input (0 V to 10 V, scalable or can be used a 4th digital input)
Relay Output	1, programmable 30 V DC / 5 A (resistive), 250 V AC 2 A (inductive)
Serial Interfaces	RS-232
Elektromagnetische Verträglichkeit	Als Zubehör EMV-Filter nach EN 55011, Klasse B; (Abstrahlung: Klasse A)
Electromagnetic Compatibility	Optional EMC filters to EN55011 Class B. (Radiated Emission: Class A)
Braking	DC Braking, Compound Braking and Electro-mechanical Brake control as option.
Protection Level	IP66 for MICROMASTER 411 (NEMA 3 only)IP55 for COMBIMASTER 411
Operating Temperature	-10 °C to +40 °C (50 °C with derating)
Storage Temperature	-40 °C to +70 °C
Humidity	99% RH – non-condensing
Operational Altitudes	Up to 1000 m above sea level without derating
Protection Features	Undervoltage, Overvoltage, Short circuit, Stall Prevention, Motor Overtemperature I2t (Option for PTC), Inverter Overtemperature, Parameter Lock
Standards	CE
CE Marked	Conformity with EC Low Voltage Directive 73/23/EECand Electromagnetic Compatibility Directive 89/336/EEC

7.2 Case Size Rating Information

Table 7-2 Case Size B

MICROMASTER 411 / COMBIMASTER 411					
Frame size:					
2 pole	71M	71M	80M	80M	90S
4 pole	71M	80M	80M	90S	90L
Motor Output Rating	0.37 kW 0.5 hp	0.55 kW 0,75 hp	0.75 kW 1,0 hp	1,1 kW 1,5 hp	1,5 kW 2,0 hp
Operating Input Voltage (rms)	3 AC 380 V – 480 V ± 10 %				
Operating Input Frequency	47 – 63 Hz				
Output Frequency 2 pole 4 pole	0 – 650 Hz				
Inrush Current	< 4 A				
Input Current (rms)	1.6 A	2,1 A	2,8 A	4,2 A	5,8 A
Output Current (max)	1.2 A	1,6 A	2,1 A	3,0 A	4,0 A
Power Supply fuse	10 A				
Power Supply Lead cross-section	4 mm ² (12 AWG)				

Table 7-3 Case Size C

MICROMASTER 411 / COMBIMASTER 411		
Frame size:		
2 pole	90L	100L
4 pole	100L	100L
Motor Output Rating	2.2 kW 3.0 hp	3,0 kW 4,0 hp
Operating Input Voltage (rms)	3 AC 380 V – 480 V ± 10 %	
Operating Input Frequency	47 – 63 Hz	
Output Frequency 2 pole 4 pole	0 – 650 Hz	
Inrush Current	< 7.7 A	
Input Current (rms)	7.8 A	10 A
Output Current (max)	5.9 A	7,7 A
Power Supply fuse	16 A	
Power Supply Lead cross-section	4 mm ² (12 AWG)	

7.3 Tightening Torque, Cable cross sections for Power Supply and Motor Terminals

Table 7-4 Power Supply & Motor Terminal Wire Sizes/Tightening Torques

Terminals	Units of measurement	Case Size B	Case Size C
Terminal Tightening Torque	[Nm]	1,3	1,3
	[lbf.in]	12	12
Minimum Cable Cross Section	[mm ²]	1,5	2,5
	[AWG]	16	14
Maximum Cable Cross Section	[mm ²]	4	4
	[AWG]	12	12

7.4 Tightening Torque for Fixing Screws

Table 7-5 Fixing Screw Recommended Tightening Torque

Description	Units of measurement	Case Size B		Case Size C	
Inverter Cover Screws	[Nm]	2,5	(M5)	2,5	(M5)
	[lbf.in]	21,3	(M5)	21,3	(M5)
Filter Board Retention Screws	[Nm]	0,8	(M3)	0,8	(M3)
	[lbf.in]	7,0	(M3)	7,0	(M3)
I/O Board Retention Screws	[Nm]	0,8	(M3)	0,8	(M3)
	[lbf.in]	7,0	(M3)	7,0	(M3)
Terminal Housing to Motor Fixing Screws	[Nm]	1,5/2,5	M4/M5	2,5	(M5)
	[lbf.in]	10,6/21,3	M4/M5	21,3	(M5)

7.5 Fuses and Circuit Breakers

Table 7-6 MICROMASTER 411/COMBIMASTER 411 Fuses and Circuit Breakers

Inverter	Power		Case Size	Fuses	Circuit Breakers
	kW	Hp			
MICRO MICROMASTER 411 COMBIMASTER 411(without filter)380 V to 480 V 3 AC	0.37	0.5	B	3NA3803	3RV1021-1CA10
	0.55	0.75	B	3NA3803	3RV1021-1DA10
	0.75	1.0	B	3NA3803	3RV1021-1EA10
	1.1	1.5	B	3NA3803	3RV1021-1GA10
	1.5	2.0	B	3NA3803	3RV1021-1HA10
	2.2	3.0	C	3NA3805	3RV1021-1JA10
	3.0	4.0	C	3NA3805	3RV1021-4KA10
MICROMASTER 411 COMBIMASTER 411(with Class B filter)380 V to 480 V 3 AC	0.37	0.5	B	3NA3803	3RV1021-1CA10
	0.55	0.75	B	3NA3803	3RV1021-1DA10
	0.75	1.0	B	3NA3803	3RV1021-1EA10
	1.1	1.5	B	3NA3803	3RV1021-1GA10
	1.5	2.0	B	3NA3803	3RV1021-1HA10
	2.2	3.0	C	3NA3805	3RV1021-1JA10
	3.0	4.0	C	3NA3805	3RV1021-1KA10

For UL listing a suitable UL recognised fuse or listed circuit breaker/self-protected combination motor controller must be used.

8 Options

This chapter contains:

An overview of the options available for the MICROMASTER 411 / COMBIMASTER 411. For further information about options, please refer to the catalog or the documentation CD.

8.1	Options – Overview.....	110
8.2	Programming Options.....	111
8.3	Communication modules.....	117
8.4	Brake function modules.....	120
8.5	Wall mounting kit.....	122

8.1 Options – Overview

Software and Operator control

- Basic Operator Panel (BOP)
- Advanced Operator Panel (AOP)
- Operator Panel Mounting Kit (includes: Desktop Frame + Interface Link Cable)
- Connection Set for PC to Inverter (includes RS 232 standard cable and adapter for operator panel mounting kit)
- Connection Set for PC to AOP
- Operator Panel Door Mounting Kit for Single Inverter
- 5 m Cable Assembly for Door Mounting Kit
- Interface Link Cable

Communication modules

- PROFIBUS Module
- AS-Interface Module
- DeviceNet Module

Brake function modules

- REM Module
- EM Module

Wall mounting kit

- Wall mounting kit for MICROMASTER 411

8.2 Programming Options

Table 8-1 Key to Programming Options

Component	Option 1	Option 2	Option 3	Option 4	Option 5
	Operator Panel programming	PC Programming (without Isolation)	PC Programming (with Isolation)	Desk Programming of AOP for Inverter programming	Door mounted operator panel
Operator Panel Mounting Kit (6SE6401-1DF00-0AA0)	<input checked="" type="checkbox"/> ²⁾		<input checked="" type="checkbox"/> ²⁾		
Interface Link Cable (6SE6401-1BL00-0AA0)		<input checked="" type="checkbox"/>		<input checked="" type="checkbox"/>	
PC-Inverter Connection Kit (6SE6400-1PC00-0AA0)			<input checked="" type="checkbox"/> ³⁾		
PC-AOP Connection Kit (6SE6400-0PA00-0AA0)				<input checked="" type="checkbox"/>	
Operator Panel Door Mounting Kit for Single Inverter (6SE6400-0PM00-0AA0)					<input checked="" type="checkbox"/>
BOP (6SE6400-0BP00-0AA0)	<input checked="" type="checkbox"/> ¹⁾				<input checked="" type="checkbox"/> ¹⁾
AOP (6SE6400-0AC00-0AA0)	<input checked="" type="checkbox"/> ¹⁾			<input checked="" type="checkbox"/>	<input checked="" type="checkbox"/> ¹⁾
5 m cable assembly, M12 connector (6SE6401-1CA00-0AA0)					<input checked="" type="checkbox"/>

NOTES

- 1) Either BOP or AOP is required.
 - 2) The Operator Panel Mounting Kit includes an Operator Desktop Frame and an Interface Link Cable.
 - 3) The Connection Set for PC to Inverter includes an RS 232 Standard Cable and an adapter for the Operator Panel Mounting Kit.
- Options 2 and 3 are for use with DriveMonitor Commissioning Software Tool.

Connection BOP or AOP

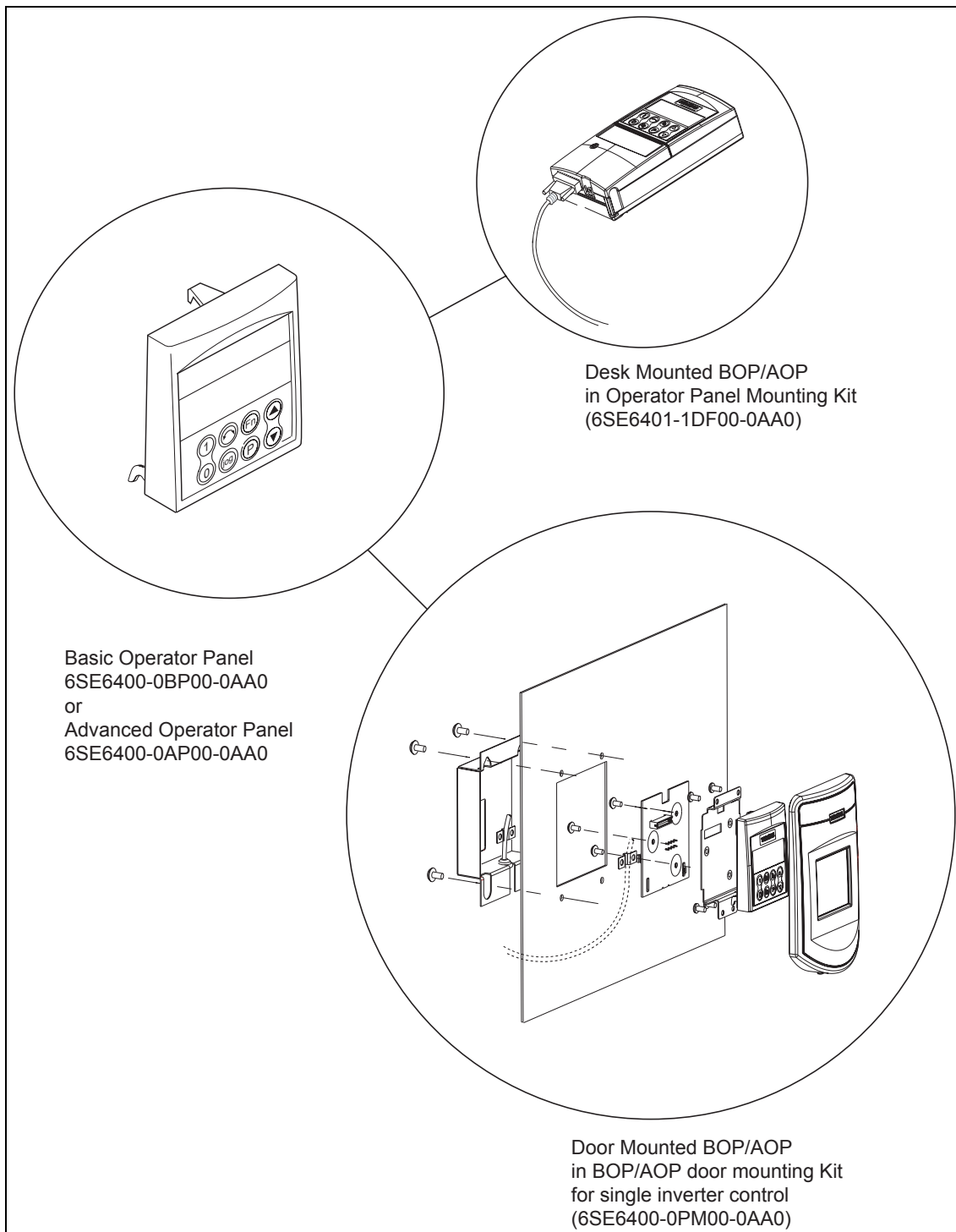

Figure 8-1 Connection BOP or AOP with Operator Panel Mounting Kit or Operator Panel Door Mounting Kit

Operator Panel Mounting Kit

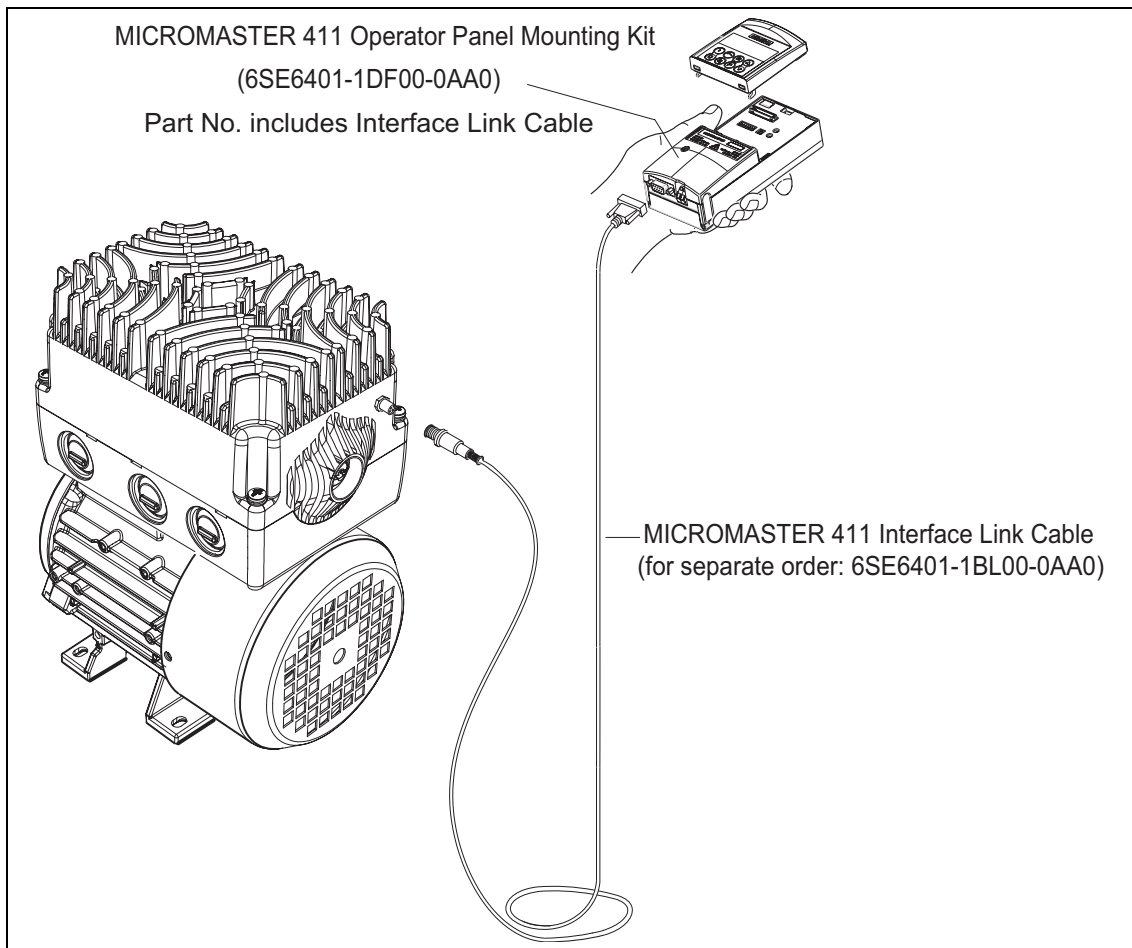

Figure 8-2 Operator Panel Mounting Kit

Operator Panel Door Mounting Kit for Single Inverter

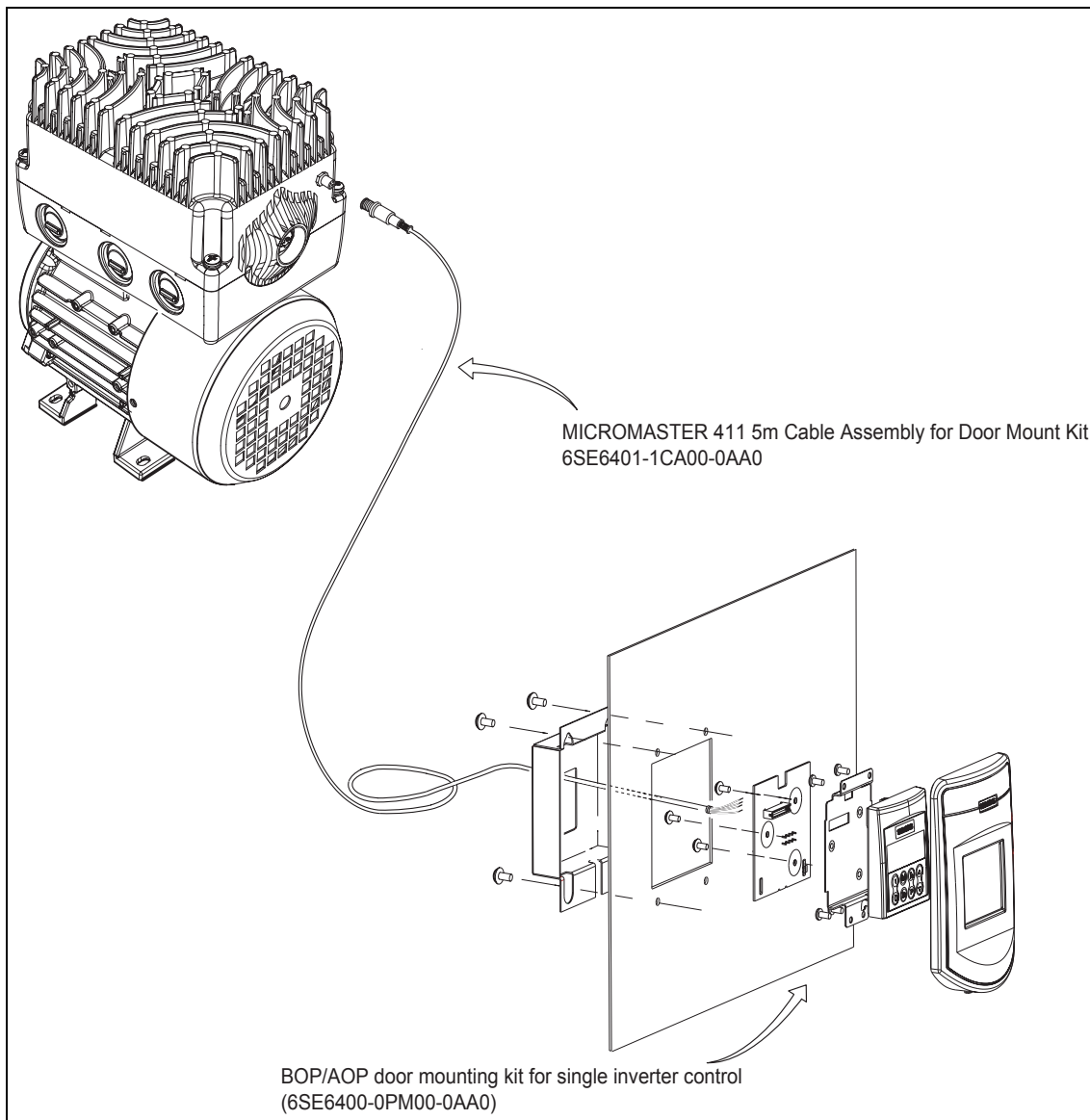

Figure 8-3 Operator Panel Door Mounting Kit for Single Inverter

PC-Inverter Connection Kit

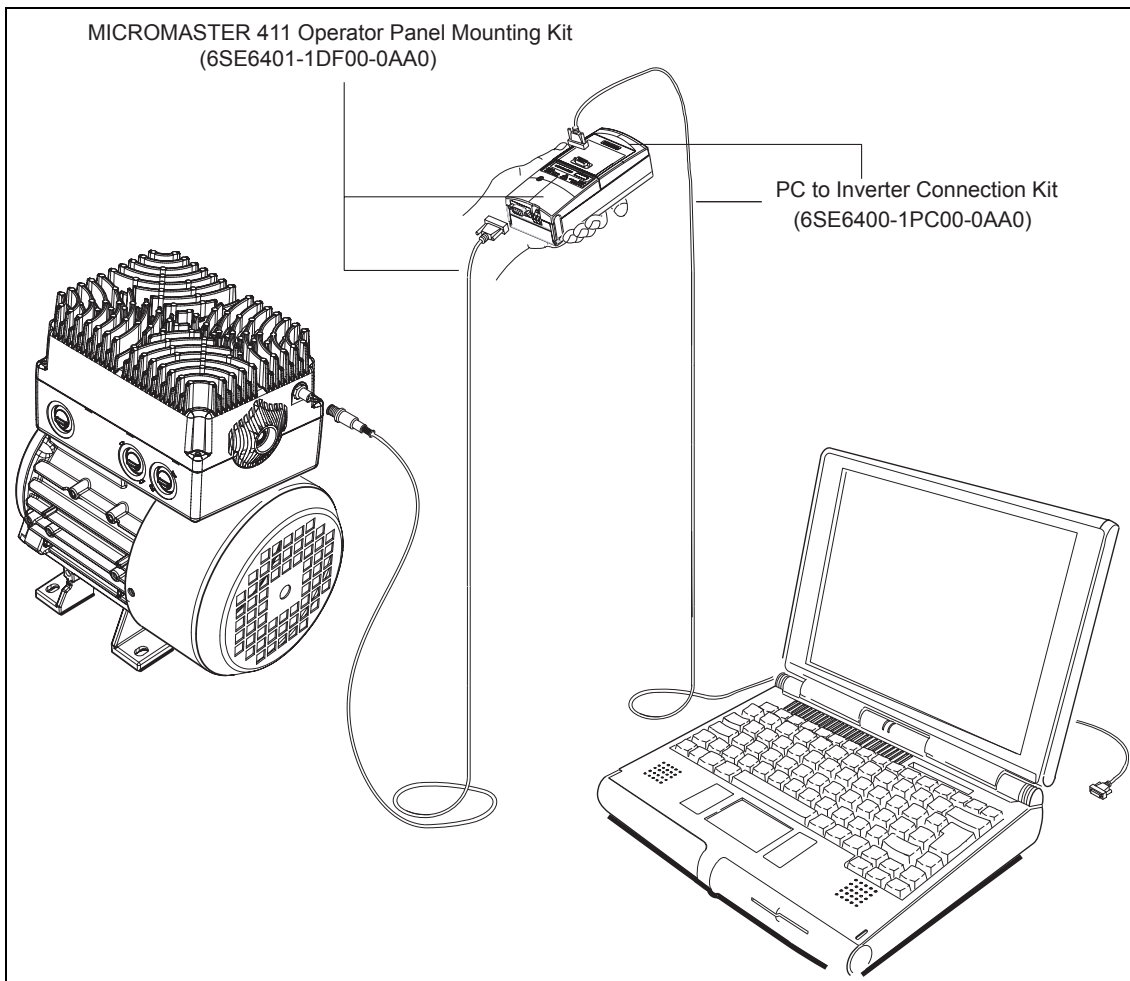

Figure 8-4 Programming via PC, isolated

PC-AOP Connection Kit

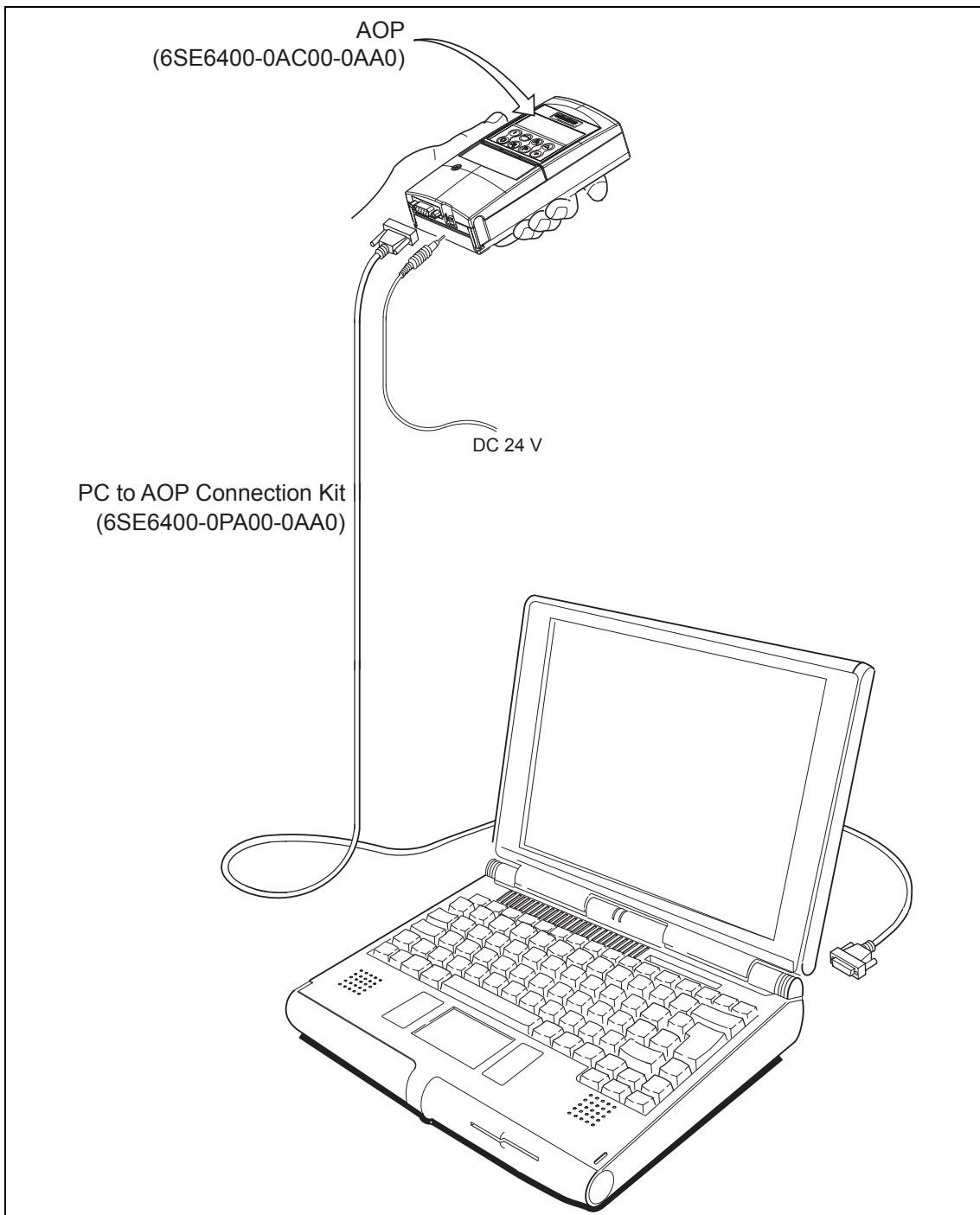

Figure 8-5 PC-AOP Connection Kit

8.3 Communication modules

PROFIBUS Module

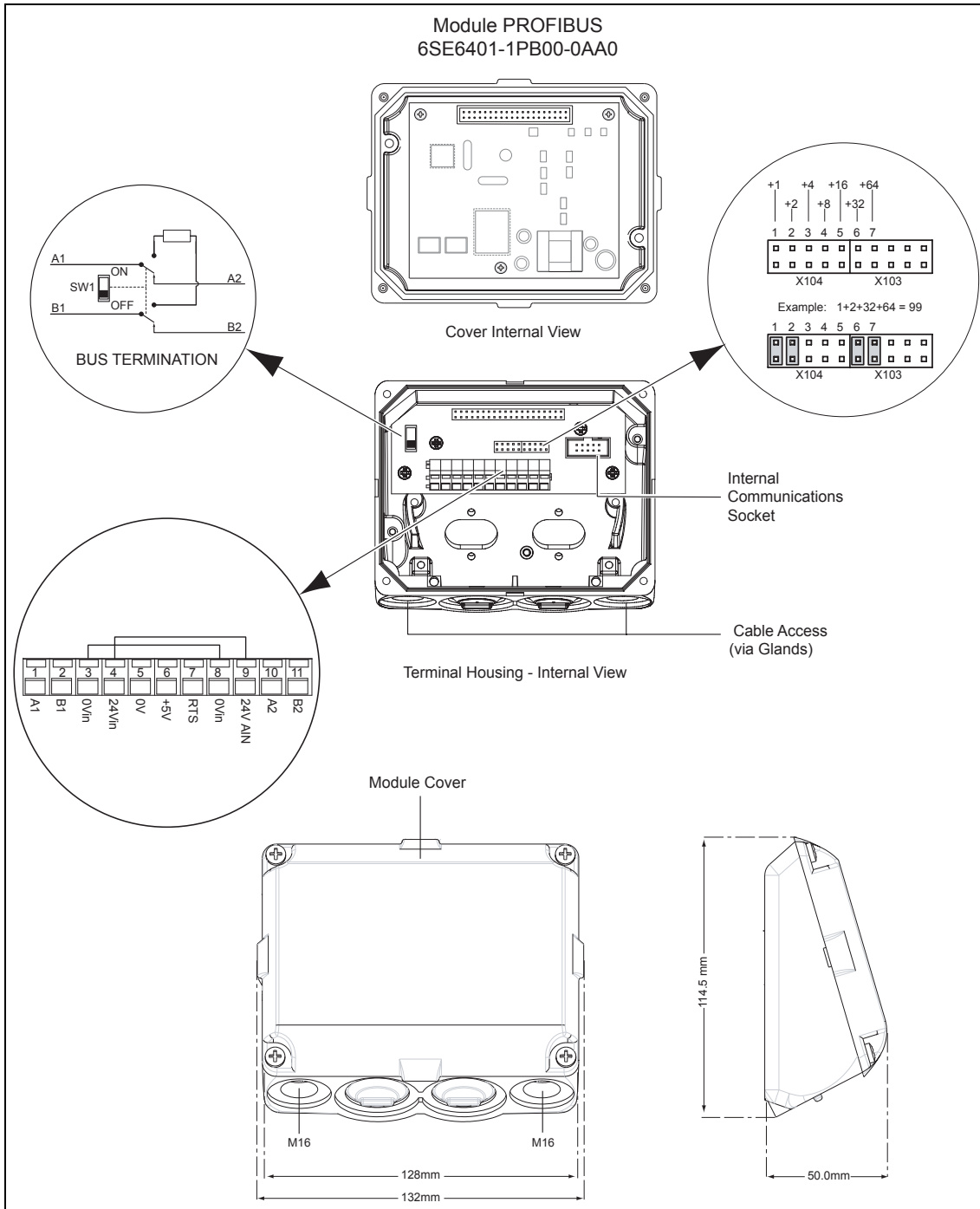

Figure 8-6 PROFIBUS Module

AS-Interface Module

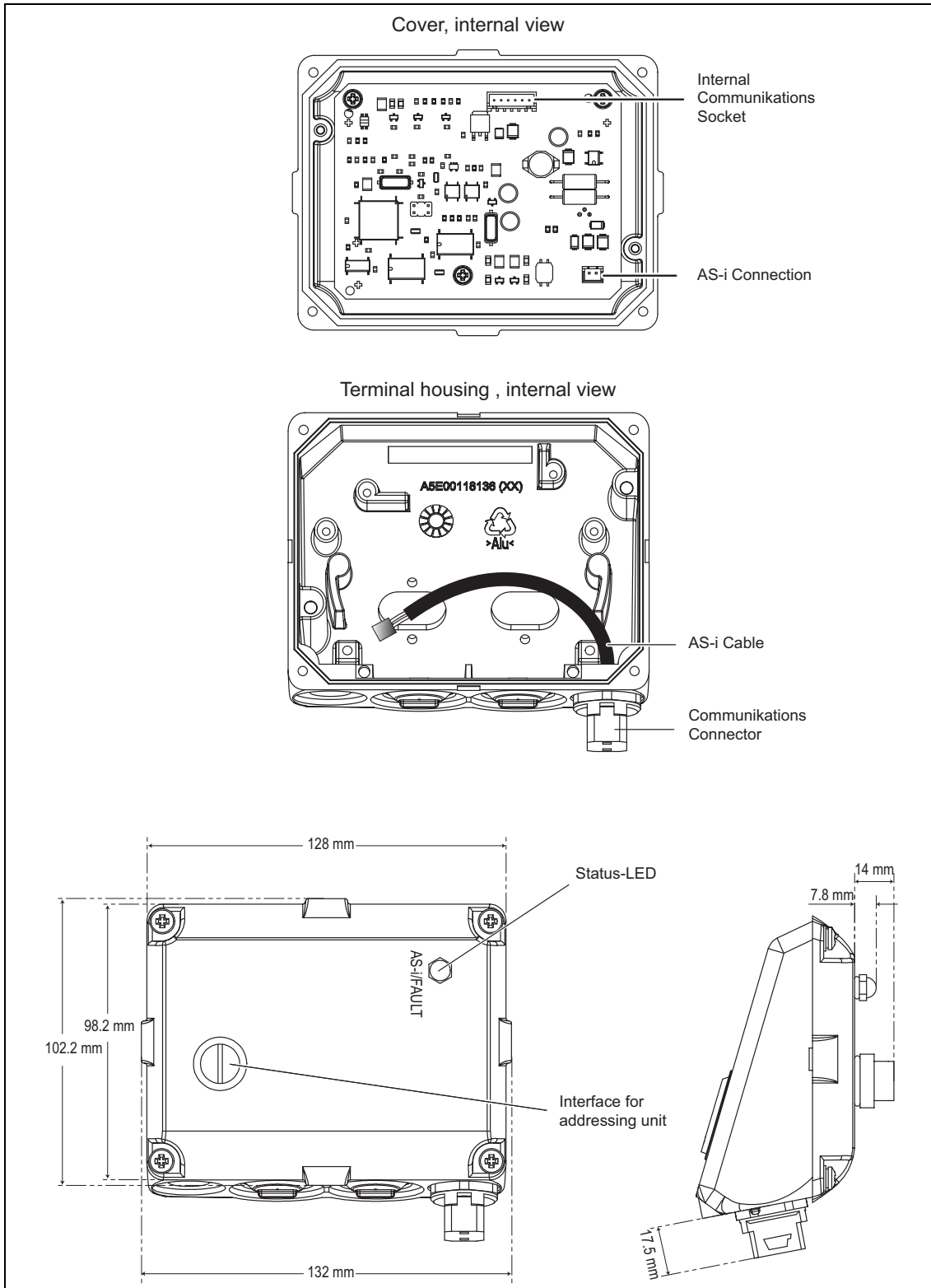

Figure 8-7 AS-Interface Module

DeviceNet Module

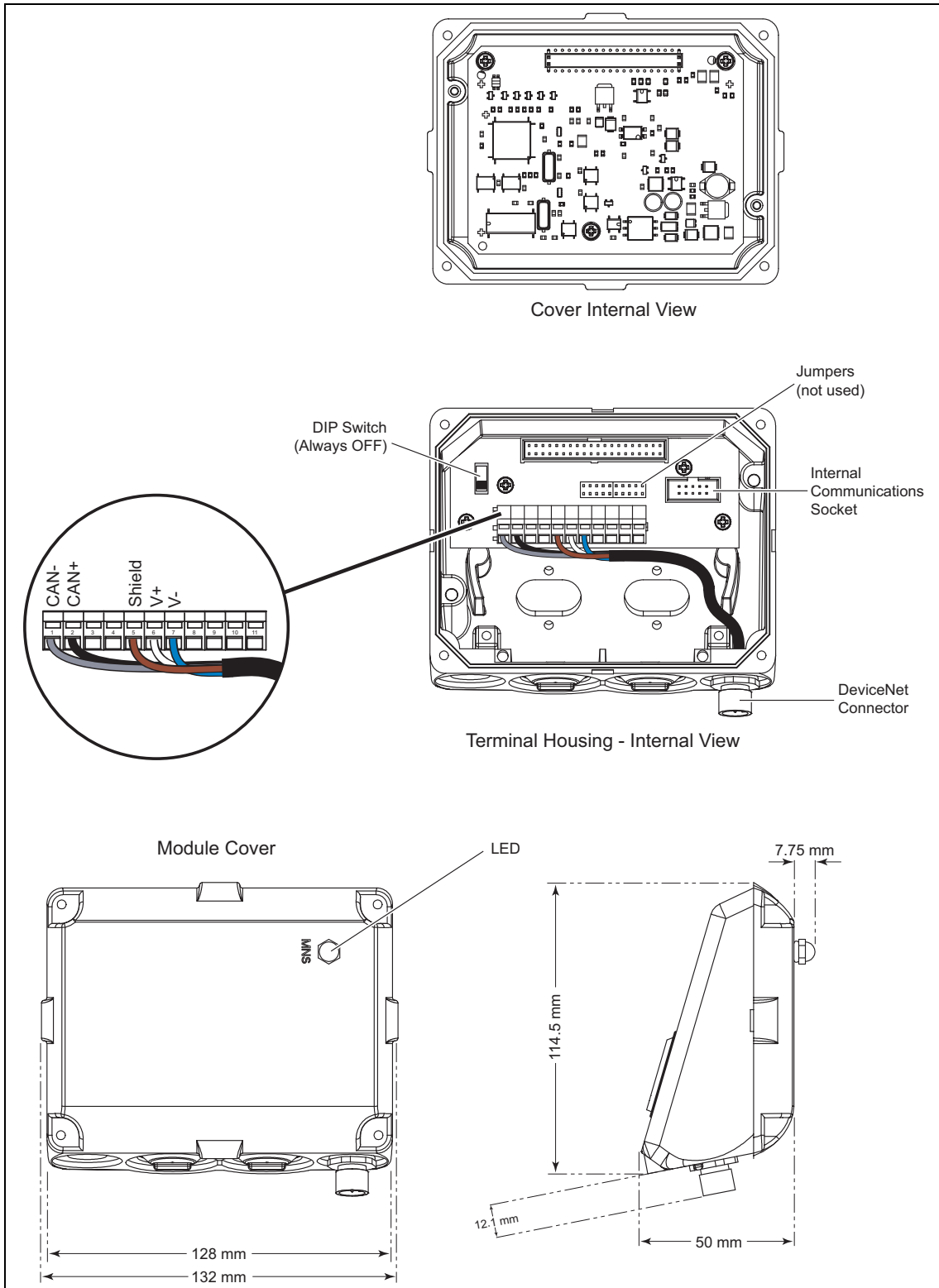

Figure 8-8 DeviceNet Module

8.4 Brake function modules

REM Module

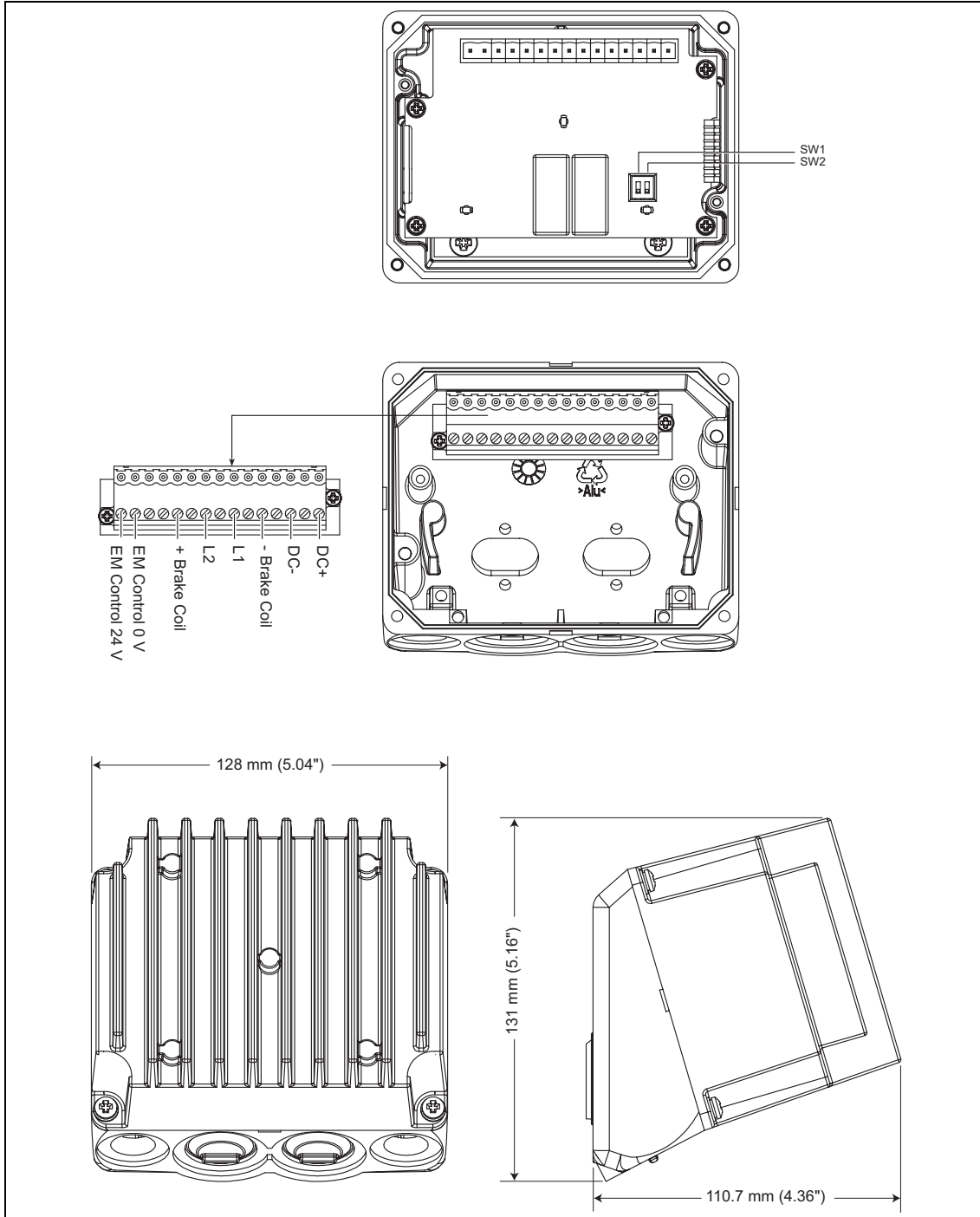

Figure 8-9 REM Module

EM Module

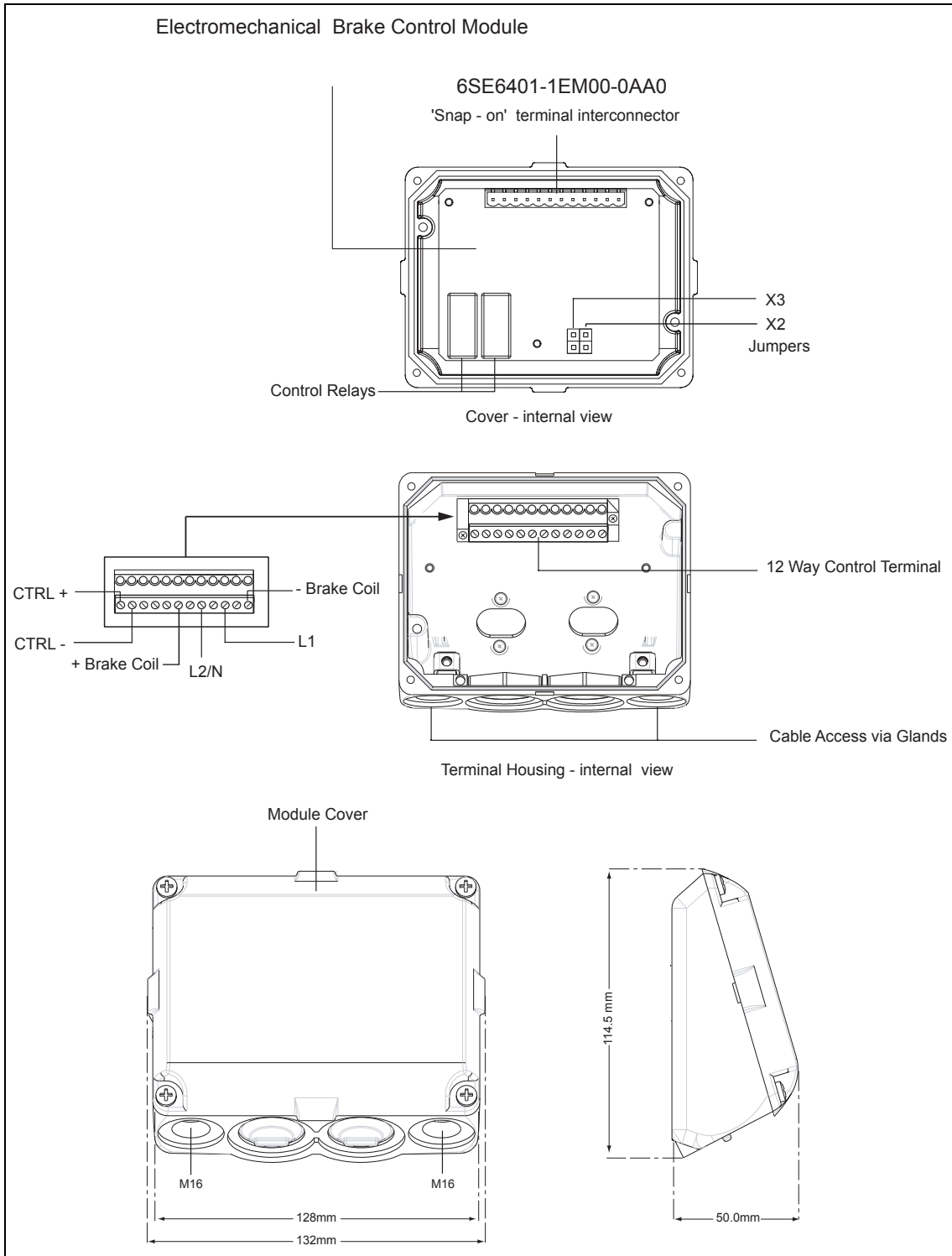

Figure 8-10 EM Module

8.5 Wall mounting kit

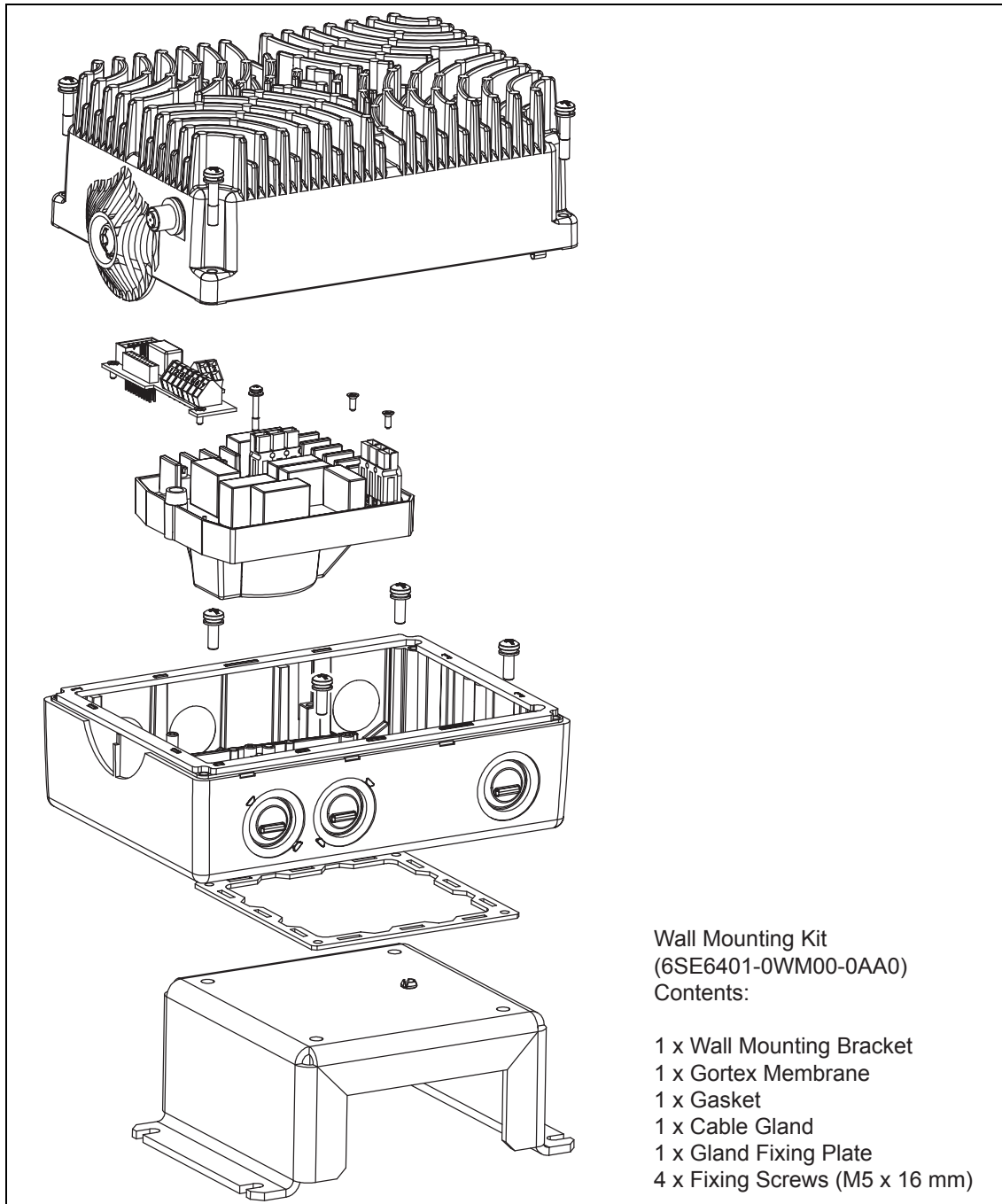

Figure 8-11 Wall mounting kit for MICROMASTER 411

9 Electro-Magnetic Compatibility (EMC)

This Chapter contains:

EMC information.

9.1	Electro-Magnetic Compatibility (EMC).....	124
9.1.1	Self-Certification.....	124
9.1.2	Technical Construction File	124
9.1.3	Emc Type Test Certificate	124
9.2	EMC Directive Compliance with Harmonics Regulations	125
9.2.1	Environment Classes of EMC performance	125
9.2.2	MICROMASTER 411 – EMC Compliance.....	128

9.1 Electro-Magnetic Compatibility (EMC)

All manufacturers / assemblers of electrical apparatus which “performs a complete intrinsic function and is placed on the market as a single unit intended for the end user” must comply with the EMC directive EEC/89/336.

There are three routes for the manufacturer/assembler to demonstrate compliance:

9.1.1 Self-Certification

This is a manufacturer's declaration that the European standards applicable to the electrical environment for which the apparatus is intended have been met. Only standards that have been officially published in the Official Journal of the European Community can be cited in the manufacturer's declaration.

9.1.2 Technical Construction File

A technical construction file can be prepared for the apparatus describing its EMC characteristics. This file must be approved by a ‘Competent Body’ appointed by the appropriate European government organization. This approach allows the use of standards that are still in preparation.

9.1.3 Emc Type Test Certificate

This approach is only applicable to radio communication transmitting apparatus. All MICROMASTER units are certified for compliance with the EMC directive, when installed in accordance with the recommendations in Section 2 of this document.

9.2 EMC Directive Compliance with Harmonics Regulations

EN 61000-3-2 "Limits for harmonic current emissions (equipment input ≤ 16 A per phase)".

All Siemens variable speed drives of the MICROMASTER, MIDIMASTER, MICROMASTER Eco and COMBIMASTER ranges, which are classified as "Professional Equipment" within the terms of the standard, fulfill the requirements of the standard.

9.2.1 Environment Classes of EMC performance

General classes of EMC performance are available as detailed below:

Class 1: General Industrial

Compliance with the EMC Product Standard for Power Drive Systems EN 68100-3 for use in **Second Environment (Industrial)** and **Restricted Distribution**.

Table 9-1 Environment - General Industrial

EMC Phenomenon	Standard	Level
Emissions:		
Radiated Emissions	EN 55011	Level A1
Conducted Emissions	EN 61800-3	European Amendment EN61800-3-A13
Immunity:		
Electrostatic Discharge	EN 61000-4-2	8 kV air discharge
Burst Interference	EN 61000-4-4	2 kV power cables, 1 kV control
Radio Frequency Electromagnetic Field	IEC 1000-4-3	26-1000 MHz, 10 V/m

Class 2: Filtered Industrial

This level of performance will allow the manufacturer/assembler to self-certify their apparatus for compliance with the EMC directive for the industrial environment as regards the EMC performance characteristics of the power drive system. Performance limits are as specified in the Generic Industrial Emissions and Immunity standards EN 50081-2 and EN 50082-2.

Table 9-2 Class 2 - Filtered Industrial

EMC Phenomenon	Standard	Level
Emissions:		
Radiated Emissions	EN 55011	Level A1
Conducted Emissions	EN 55011	Level A1
Immunity:		
Supply Voltage Distortion	IEC 1000-2-4 (1993)	
Voltage Fluctuations, Dips, Unbalance, Frequency Variations	IEC 1000-2-1	
Magnetic Fields	EN 61000-4-8	50 Hz, 30 A/m
Electrostatic Discharge	EN 61000-4-2	8 kV air discharge
Burst Interference	EN 61000-4-4	2 kV power cables, 2 kV control
Radio Frequency Electromagnetic Field, amplitude modulated	ENV 50 140	80-1000 MHz, 10 V/m, 80% AM, power and signal lines
Radio-frequency Electromagnetic Field, pulse modulated	ENV 50 204	900 MHz, 10 V/m 50% duty cycle, 200 Hz repetition rate

Class 3: Filtered - for residential, commercial and light industry

This level of performance will allow the manufacturer / assembler to self-certify compliance of their apparatus with the EMC directive for the residential, commercial and light industrial environment as regards the EMC performance characteristics of the power drive system. Performance limits are as specified in the generic emission and immunity standards EN 50081-1 and EN 50082-1.

Table 9-3 Class 3 - Filtered for Residential, Commercial and Light Industry

EMC Phenomenon	Standard	Level
Emissions:		
Radiated Emissions	EN 55011	Level A (Restricted Distribution)
Conducted Emissions	EN 55011	Level B
Immunity:		
Supply Voltage Distortion	IEC 1000-2-4 (1993)	
Voltage Fluctuations, Dips, Unbalance, Frequency Variations	IEC 1000-2-1	
Magnetic Fields	EN 61000-4-8	50 Hz, 30 A/m
Electrostatic Discharge	EN 61000-4-2	8 kV air discharge
Burst Interference	EN 61000-4-4	2 kV power cables, 2 kV control
Radio Frequency Electromagnetic Field, amplitude modulated	ENV 50 140	80-1000 MHz, 10 V/m, 80% AM, power and signal lines
Radio-frequency Electromagnetic Field, pulse modulated	ENV 50 204	900 MHz, 10 V/m 50% duty cycle, 200 Hz repetition rate

NOTICE

- MICROMASTER 411/COMBIMASTER 411 inverters are intended exclusively for professional applications. Therefore, they do not fall within the scope of the harmonics emissions specification EN 61000-3-2.
- Class A filtered inverters can be used in this environment under "Restricted Distribution" (Professional Applications) in accordance with EN61800 Part 3.
- Dedicated EMC Product Standards can exist for this equipment/units/machine/plant, which the manufacturer must then observe.

Table 9-4 EMC Compliance Table

Model	Remarks
Class 1 – Environment – General Industrial	
6SE6411-6U***-**A1 1UA1**-*J**	Unfiltered units, all voltages and powers.
Class 2 – Environment – Filtered Industrial (All EU countries for year 2002)	
6SE6411-6B***-**A1 1UA1**-*B**	Filtered units all voltages and powers.
Class 3 – Environment – Filtered for residential, commercial and light industry	
6SE6411-6B***-**A1 1UA1**-*B**	Filtered units all voltages and powers.
* Denotes any value is allowed	

9.2.2 MICROMASTER 411 – EMC Compliance

The MICROMASTER 411 inverters will, when correctly installed and put to their intended use, satisfy the requirements of the EEC Directive 89/336/EEC concerning electromagnetic compatibility.

If the guidelines on installation to reduce the effects of electromagnetic interference are followed, the devices are suitable for installation in machines. According to the machinery directive, these machines must be separately certified.

Table 9-5 below lists the measured results for emissions of an immunity to interference for the MICROMASTER 411 inverters.

Table 9-5 MICROMASTER 411 Measured Results

Test Standard	Measurement	Test Value	Limit Value
RFI Emissions	Conducted via Mains Cable	150 kHz to 30 MHz	Unfiltered – not tested Class B
	Emitted by the inverter	30 MHz to 1 GHz	All devices – Class A

10 Engineering Information

This Chapter contains:

- Operating Modes
- Derating Factors
- Motor and Inverter Protection

10.1	Current Limit and Overload Operation.....	131
10.1.1	Current Monitoring Accuracy	132
10.1.2	Fast Current Limit	133
10.1.3	Positive Temperature Coefficient Resistor Use	133
10.1.4	I ² t Performance	134
10.1.5	Internal Overtemperature.....	134
10.1.6	Overvoltage and Trip Levels.....	135
10.2	Control and Operating Modes.....	136
10.2.1	Boost.....	136
10.2.2	Proportional and Integral Control (PI).....	137
10.2.2.1	What is Closed Loop control?.....	137
10.2.2.2	Implementation on MICROMASTER 411/COMBIMASTER 411	138
10.2.2.3	Setting up the PI controller	138
10.2.2.4	PI Setpoint ramp times	140
10.2.2.5	PI Controller Proportional and Integral terms	140
10.2.3	Ziegler-Nichols method of Optimization.....	142
10.2.4	PI Output Limits	144
10.2.5	Further features	145
10.2.6	Energy Saving Mode.....	145
10.2.6.1	Energy Saving Mode 1 (P2390 - P2392).....	146
10.2.6.2	Energy Saving Mode 2 (P2393 - P2398).....	147
10.3	Braking.....	149
10.3.1	Normal Braking	149
10.3.2	DC Braking.....	149
10.3.3	V _{dc} Max Controller	150
10.3.4	COMPOUND Braking	151
10.4	Derating Factors	152
10.4.1	Derating with Temperature	152
10.4.2	Derating with Altitude	153
10.4.3	Derating with Switching Frequency	153

10.4.4	Derating for Inverter Orientation	154
10.5	Thermal Protection and Automatic De-rating	155
10.6	Operation from Unearthed Supplies	155
10.7	Lifetime of Inverters	155
10.8	Working with Binary Connectors (BiCo)	156
10.8.1	Introduction	156
10.8.2	How does BiCo work?.....	156
10.8.3	Using Control and Status Words with BiCo	159
10.8.4	BiCo Connections	160
10.9	Harmonic Currents.....	164
10.10	Use of MICROMASTER 4 Input Chokes	164
10.11	Power Losses	165
10.12	Shock and Vibration.....	166
10.12.1	Vibration Stress during Operation (Single Sine Sweep).....	166
10.12.2	Shock Stress during Operation (Half Sine Shock).....	166
10.12.3	Vibration and Shock stress during Transport	166
10.13	PROFIBUS.....	167
10.13.1	PROFIBUS Module.....	168
10.13.2	Features of PROFIBUS Module	168
10.14	Variant Independent Options	172
10.14.1	Basic Operating Panel (BOP).....	172
10.14.2	Advanced Operating Panel (AOP).....	172
10.14.3	PROFIBUS Module.....	173
10.14.4	PC to Inverter Connection Kit	173
10.14.5	BOP/AOP Door Mounting Kit for Single Inverter Control.....	173
10.14.6	EM Module.....	173
10.14.7	REM Module	174

10.1 Current Limit and Overload Operation

The inverter will always protect itself, the motor and the system from possible damage. Where a short circuit exists on the output of the inverter, the unit will trip almost instantaneously to protect itself. In the event of short and/or long term overload conditions, current limit protection now operates rapidly to reduce inverter current and prevent a trip occurring.

Electronic Trip

This is a very fast current limit, which operates if there is a short circuit (line to line or most of line to earth faults) on the output. It is a fixed level trip and operates within a few microseconds.

Overload Limit

This is a very fast limit, which operates within a few microseconds and removes some of the output pulses to limit the current and protect the inverter. If this pulse dropping occurs during overload, the operating condition will usually recover and the motor will continue to run without tripping.

Long Term Overload Limit

This is a slower limit which allows an overload of at least 60 seconds where the current lies above the motor limit but below the Electronic Trip and Overload Limit.

Continuous Limit

This is the level set as the maximum continuous motor current. The inverter will control the current to this level after other overloads have timed out.

Figure 10-1 illustrates the interaction of parameters associated with current limit. Read Only parameters r0027, r0034, r0037 and r0067 help with fault diagnosis.

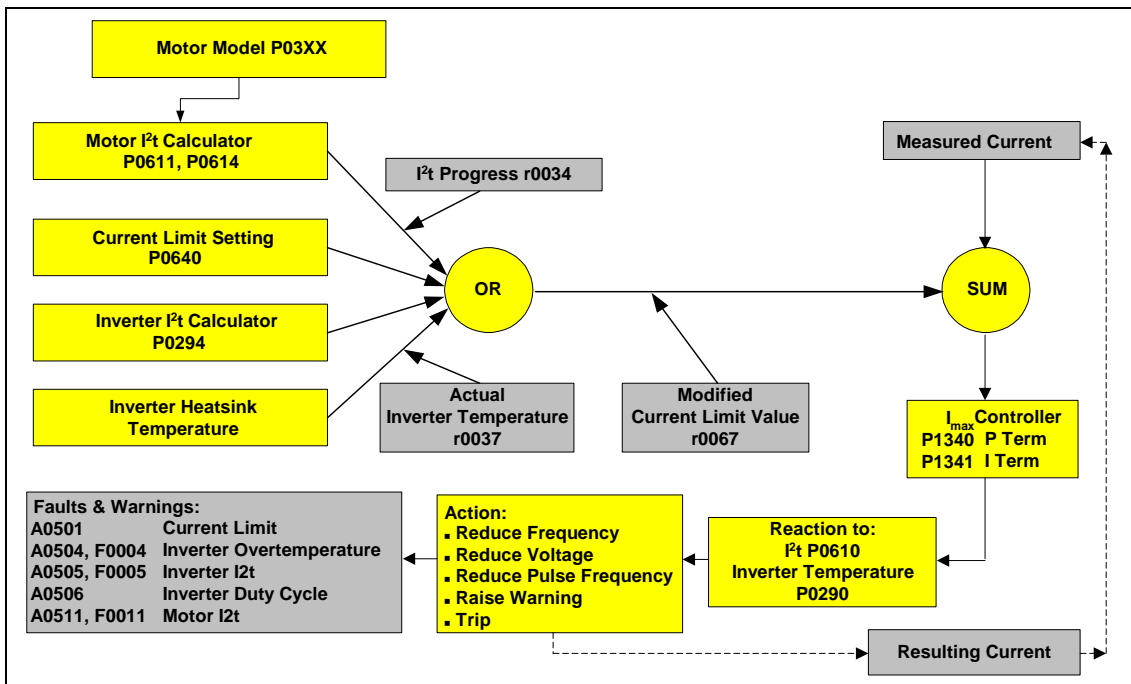

Figure 10-1 Current Limit Interaction

10.1.1 Current Monitoring Accuracy

Figure 10-1 shows sample results comparing current measured with a current scope, and the current displayed on the inverter, using measurements taken from a variety of inverters at various switching frequencies, current loads, frequency setpoints and cable lengths.

Table 10-1 Measured Current Monitoring Accuracy

Inverter	Frame Size B, 400 V 1.5 kW	Frame Size C, 400 V 3.0 kW
Switching frequency	4 kHz	4 kHz
Load on inverter	Nominal load 4 A	Nominal load 7.7 A
Frequency setpoint	45 Hz	45 Hz
Scope current (long cable)*	4.00 A	7.70 A
Drive current	4.05 A	7.46 A
% difference (inverter/scope)*	1.32 %	-3.9 %

10.1.2 Fast Current Limit

Fast Current Limit (FCL) is a cycle-by-cycle hardware current limit built into the inverter. The current is rapidly reduced by pulse dropping, that is by turning off the Insulated Gate Bipolar Transistors (IGBTs) on a pulse by pulse (cycle by cycle) basis. The normal current limit operation then takes over.

The FCL threshold is set slightly below the software overcurrent trip threshold and reacts much quicker (i.e. in milliseconds), thus preventing spurious and unwanted trips when sudden loads are applied or fast accelerations requested.

FCL is especially useful when working in open loop control to override unwanted currents.

10.1.3 Positive Temperature Coefficient Resistor Use

Many motors are available with a Positive Temperature Coefficient (PTC) resistor built into the windings. The resistance of the resistor rises rapidly at a particular temperature and this change can be detected by the inverter. If the resistor is connected to the inverter terminals as shown in Figure 10-2 and the PTC input enabled by setting parameter P0703=29, then if the resistance rises above 2 k Ω , the inverter will trip and Fault Code F0085 displayed.

Most Motor Protection PTC resistors have a resistance of 200-300 ohms when cold and this value rises rapidly at the 'knee point' to typically 10 k Ω and greater. The PTC input is set so that it will operate at 1 k Ω minimum, 1.5 k Ω nominal, and 2 k Ω maximum. Additionally the input has a strong filter because the PTC connection usually causes electromagnetic interferences. On this basis two or three PTCs may be connected in series when a motor has more than one PTC built in, or if two or three motors are connected to the inverter output and require individual protection.

To activate the switch-off for motor overtemperature set parameter P0701, P0702 or P0703 = 29 (external fault). If the resistor of the PTC temperature sensor exceeds the motor trip level (motor overtemperature), it causes fault F0085 (external fault).

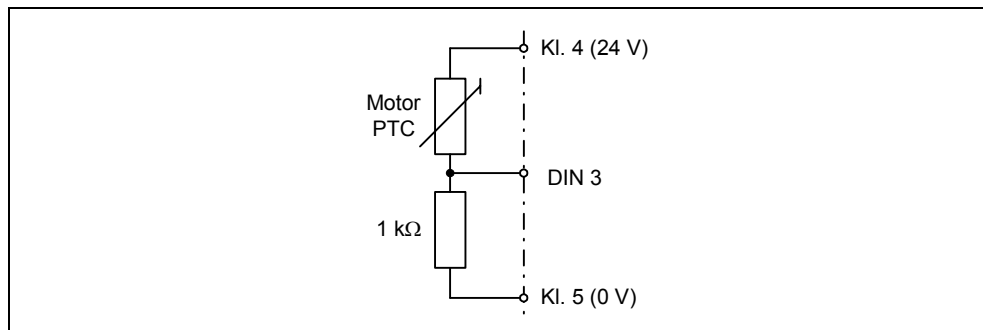

Figure 10-2 PTC Resistor Connections

10.1.4 I²t Performance

When the motor is running at low speed and high load, the built-in cooling fan may not provide enough cooling and the motor may overheat. Parameter P0610 allows a frequency dependent I²t limit to be enabled to protect the motor.

When the inverter is operating in the region above the selected curve (i.e. at low frequency and high current), a timer is started, and after some time, (based on the current, the motor size and previous operating history), the inverter will trip or reduce output frequency. Trip or reduction of output frequency will depend on the parameter setting.

10.1.5 Internal Overtemperature

Under normal circumstances, the inverter will not overheat. The heatsink maintains the inverter at normal operating temperature. Careful consideration when mounting the inverter will ensure adequate ventilation and reduce the likelihood of overheating. Check to see that airflow remains unrestricted. There should be a minimum clearance of 100 mm free space around the Inverter.

Heatsink temperature is monitored using a PTC resistor and the inverter will trip if the maximum temperature is exceeded. If the inverter persistently trips, you should check for high ambient temperature or blocked airflow.

You can verify heatsink temperature by displaying Parameter r0037. Units are given in degrees Celsius (°C).

10.1.6 Overvoltage and Trip Levels

The inverter will protect itself from both supply overvoltage and undervoltage. Trip levels are shown in Table 10-2. Internal overvoltage can occur during braking where internal voltages are forced high by energy from an external load.

Table 10-2 Trip Levels

Input Supplies	Undervoltage trip levels	Overvoltage trip levels
3 AC 400 V	DC 410 V	DC 820 V

When output pulses are disabled from the inverter an undervoltage trip will not occur. An overvoltage trip will occur at any time when the overvoltage threshold is exceeded.



CAUTION

Check to ensure you have matched the input supply to the inverter. If the supply voltage is too high, you may damage the inverter even if it trips.

10.2 Control and Operating Modes

10.2.1 Boost

Boost is used to increase the output voltage in order to overcome losses and non-linearity at low frequencies. If the correct amount of boost is applied, the current and torque will be increased at low frequencies. However, if too much boost is applied, the motor may overheat if run at low frequencies for a long time and excessive boost may also saturate the motor, leading to loss of torque.

The I^2t function helps protect the motor under these circumstances. Boost is calculated such that 100% boost is the voltage given by:

Stator resistance (P0350) multiplied by rated motor current (P0305).

Which means that changing the value of these parameters will affect the boost level.

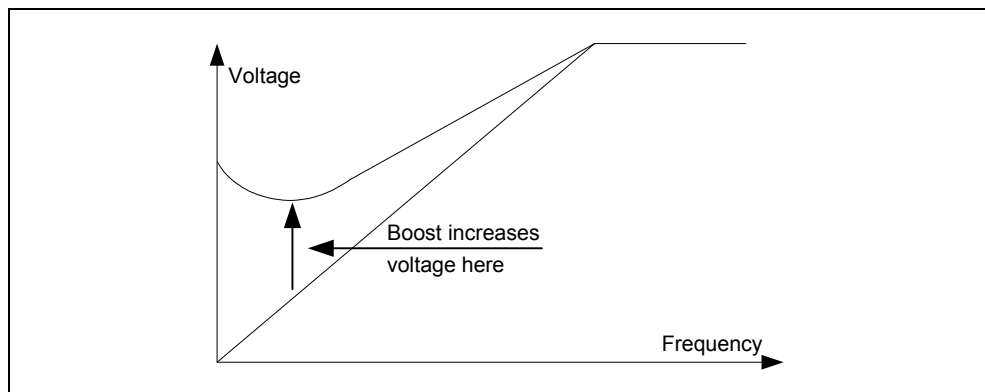

Figure 10-3 Boost Level

- P1310** This parameter sets the % boost applied at 0 Hz. The boost level is then reduced with increasing frequency to a minimum value, set by P1316, typically around about 10 Hz.
- P1311** This parameter sets a boost voltage, as P1310, except that the boost is applied only during acceleration, either following a start command or from set point changes.
- P1312** This parameter allows a constant linear boost, again as P1310, to be applied following a start command only to improve 'first time' starting.

Maximum values of P1310, 1311, and 1312 are 250%, but the overall maximum boost is limited by P0640, the motor overload setting. The boost voltage will also be limited by the operation of the I²t function, so boost may be reduced further if the motor is in danger of overheating. The progress of the I²t function can be monitored by parameter r0034.

The default settings (P1310 = 50, P1311 and P1312 = 0) allow satisfactory operation with most loads. Increasing the boost up to say 200% (note that P0640 setting will limit) on smaller motors and 100% on larger motors will often give improved torque at low frequencies. Use P1311 and P1312 to limit this to accelerating boost only (e.g. P1310 = 100, P1312 = 100), to reduce the possibility of overheating.

10.2.2 Proportional and Integral Control (PI)

NOTE

MICROMASTER 411/COMBIMASTER 411 have a built-in PI controller. References to “PID” control within parameter descriptions relates to “PI” control.

10.2.2.1 What is Closed Loop control?

Closed loop control is widely used in industrial applications to control a wide variety of processes. Control engineering is a complex subject, but a simple closed loop control uses a feedback signal from the process (such as temperature, pressure, speed) a desired value or setpoint (often set manually) and a control system that compares the two and derives an error signal. The error signal is then processed and used to control the inverter and motor (in this case) to try to reduce the error.

The error signal processing can be very complex because of delays in the system. The error signal is usually processed using a Proportional and Integral (PI) controller whose parameters can be adjusted to optimize the performance and stability of the system. Once a system is set up and stable, very efficient and accurate control can be achieved. See Figure 10-10.

10.2.2.2 Implementation on MICROMASTER 411/COMBIMASTER 411

MICROMASTER 411/COMBIMASTER 411 have a built in PI controller that can be enabled by the user to allow for closed loop control. Once the PI controller is enabled (using P2200), the PI controller internally generates the motor frequency necessary to minimize the error between the PI setpoint and the PI feedback. It does this by continuously comparing the feedback signal with the setpoint and uses the PI controller to determine the necessary motor frequency. The normal frequency setpoint (P1000 setting) and ramp times (P1120 & P1121) are automatically disabled but the minimum and maximum output frequency settings (P1080 and P1082) remain active.

10.2.2.3 Setting up the PI controller

Parameter filter for PI parameters

The PI parameters are in the range between P2200 and P2294. For most applications, the level 2 parameters are sufficient for setting up the PI controller. To access only the PI controller parameters, you can use the parameter filter as follows:

P0003 = 2

P0004 = 22

Enabling PI control

PI control is enabled using parameter P2200. For constant enabling of the PI controller this should be set to 1. It is also possible to use a digital input (or other BiCo functions) to enable the PI controller, e.g. the PI controller can be enabled using DIN 2 by setting P0702 = 99 and P2200 = 722.1. This allows the user to switch between frequency control and PI control when the inverter is not running.

PI Feedback signal

PI control requires a feedback signal from the process to monitor how the system is behaving. For the majority of applications, this will be in the form of an analogue sensor.

The MICROMASTER 411/COMBIMASTER 411 has one analogue input, terminal connections 6 & 7, and the feedback signal can be connected to this input. The source of the PI feedback signal must then be defined using P2264 = 755 (source of PI feedback = analogue input 1). If required the analogue input can be scaled using parameters P0757 – P0760. If a different source of feedback signal is used

(e.g. USS), P2264 must be set appropriately. The value of the feedback signal can be viewed via parameter r2266.

The relation between the sensor signal and the manner in which the PI controller changes the motor frequency must also be defined at this point. This is done using P2271 (PI transducer type). There are 2 possible settings for this parameter, 0 and 1. The difference between these settings is whether the PI controller increases or decreases output frequency as a response to a positive error signal (i.e. where the feedback signal is less than the setpoint). The parameter description for P2271 describes in detail how to determine which setting is correct for your application.

PI setpoint

The PI controller controls the inverter frequency by comparing the actual system behavior (via the feedback signal) with the desired system behavior. The desired behavior is defined using a setpoint. The user selects the source of the setpoint with parameter P2253. MICROMASTER 411/COMBIMASTER 411 only have one analogue input and this is most commonly used for the feedback signal, so an internal digital setpoint is usually used. There are two methods of doing this, either using the "fixed PI setpoint" or the "keypad (motorized potentiometer) setpoint".

1. P2253 = 2224
Fixed PI setpoint This method allows the user to define up to 7 setpoint values using parameters P2201 to P2207 and select between these using binary signals, usually via the digital inputs. The different selection methods are described in the parameter list under P2201.
2. P2253 = 2250
Keypad
(motorized
potentiometer)
setpoint. This method allows the user to set a fixed value in P2240. The setpoint can be increased or decreased either with the arrow keys on the BOP or more commonly via digital inputs (e.g. P0702 = 13 "increase" and P0703 = 14 "decrease").

NOTE

Values are given in % rather than Hz, and the running frequency of the inverter is determined by the difference between the setpoint and feedback signals and the action of the PI controller.

10.2.2.4 PI Setpoint ramp times

When PI control is enabled using P2200, the normal frequency ramp up and ramp down times (P1120 and P1121) are bypassed. The PI setpoint has its own ramp times, P2257 and P2258, which allow ramped PI setpoint changes.

The ramp up time, P2257, is active when the PI setpoint is changed or when a RUN command is given. The ramp down time, P2258 is only effective on PI setpoint changes. The ramp down times used after OFF1 and OFF3 commands are set in P1121 and P1135 respectively.

10.2.2.5 PI Controller Proportional and Integral terms

The user can tune the performance of the PI controller to suit the process demands by adjusting P and I terms, P2280 and P2285. The demands of the process will determine the optimal type of response, from a rapid recovery response with overshoot to a damped response. By adjusting the P and I parameters it is possible to achieve different types of response.

Example:

The following figures show how different responses to a 5% PI setpoint step change on a pressure control system. The traces show the PI feedback signal, with 1 V = 10%. The different responses are achieved by varying the settings of P2280 and P2285.

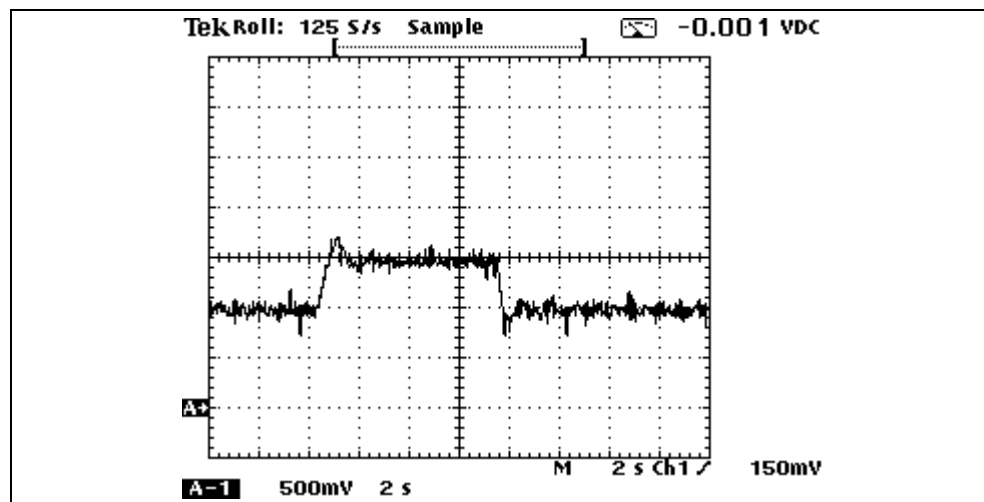

Figure 10-4 Quick response with overshoot: P2280 = 0.30; P2285 = 0.03 s

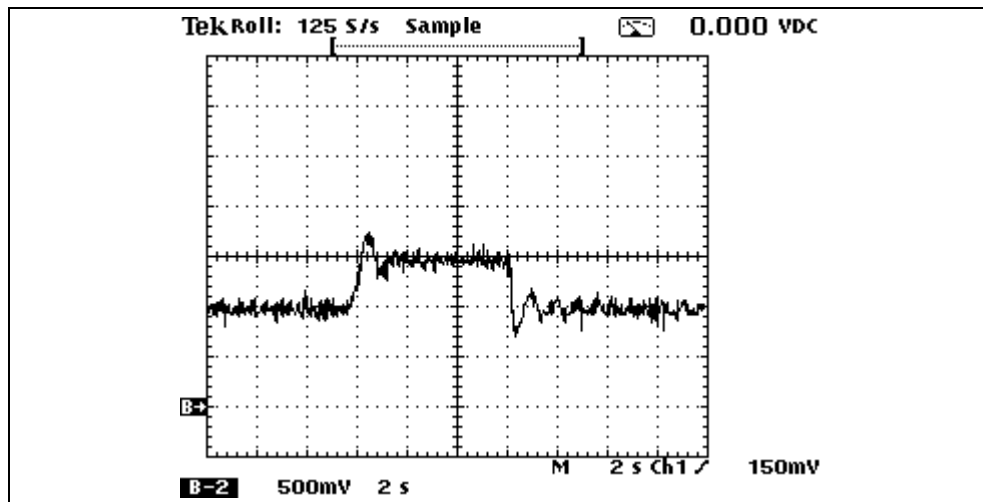

Figure 10-5 Quick response with overshoot, but instability: P2280 = 0.55; P2285 = 0.03 s

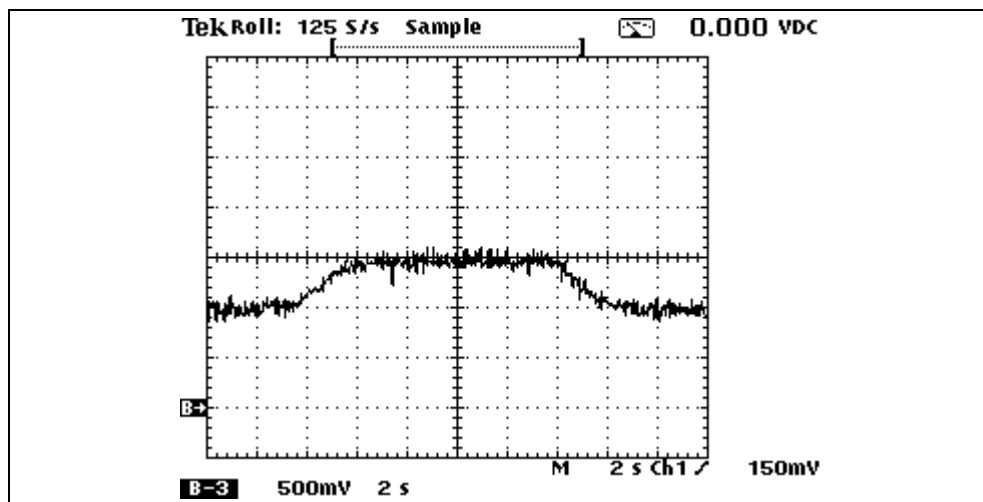

Figure 10-6 Damped response: P2280 = 0.20; P2285 = 0.15 s

Values of P2280 and P2285 are determined by the relationship between motor frequency and the PI control quantity (e.g. pressure).

When optimizing a control process an oscilloscope is recommended to monitor the feedback signal to see the system response. Most commonly small PI setpoint step changes (1- 10%) without the PI ramp times (P2257 = P2258 = 0.0 s) are used to evaluate the system response. Once the desired response profile has been achieved, the operational ramp times are then set.

It is recommended to start with a small P term (e.g. P2280 = 0.20) and adjust the I term until stable operation constant is achieved. A small PI setpoint change should then be given and depending on the system response the parameters adjusted according to the tendencies shown in the figures above.

In general, the most stable control is achieved by using both proportional and integral terms, and if the system is liable to experience sudden disturbances we would not recommend setting the P term (P2280) greater than 0.50.

A block diagram showing the relationships and interaction between PI Setpoint and PI Feedback is shown in Figure 10-10.

10.2.3 Ziegler-Nichols method of Optimization

The Ziegler-Nichols method is a means of calculating the Proportional gain and Integral time by measuring the system response to a step change in open loop. This is done by putting the inverter in frequency control and monitoring the feedback signal. From the feedback response, the time before the system starts to respond, L, and the dominant time constant, T, which is measured by estimating when the system response would have reached its stationary value if the maximum slope were maintained. (Typically measure to where the system response has reached 85% of its final value). From L, T and the ratio between the frequency step Df (as % of Fmax) to the feedback value change Dx (%), it is possible to calculate the P and I terms for a PI control process as follows:

$$\mathbf{P\ gain = (0.9)(T)(Df) / (L)(Dx)}$$

$$\mathbf{I\ time = 3L}$$

Example:

With the inverter in frequency control, a frequency step of 5 Hz is given and the feedback signal monitored. To allow this, the following parameters are set:

$$P2200 = 0$$

$$P1120 = 0,0\ s$$

$$P1121 = 0,0\ s$$

$$P1080 = 50.0\ Hz.$$

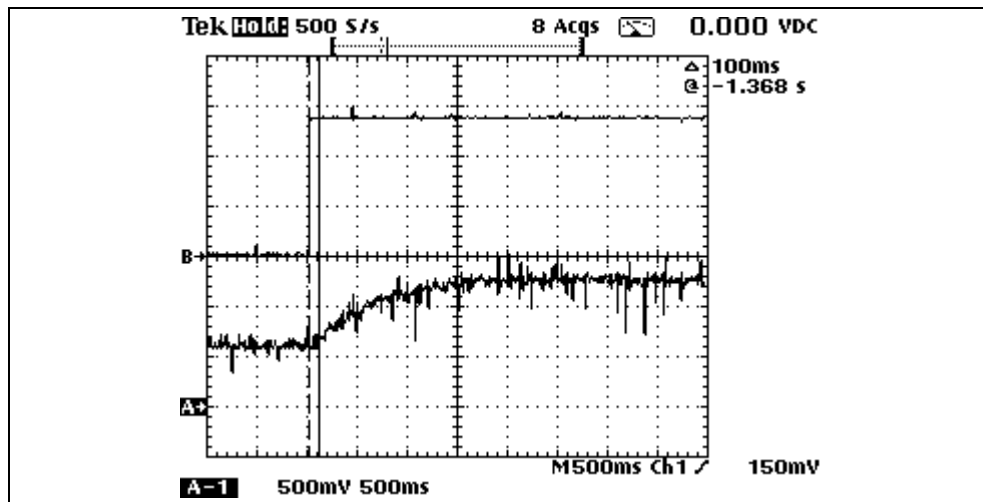

Figure 10-7 Response to 5 Hz step: L = 100 ms

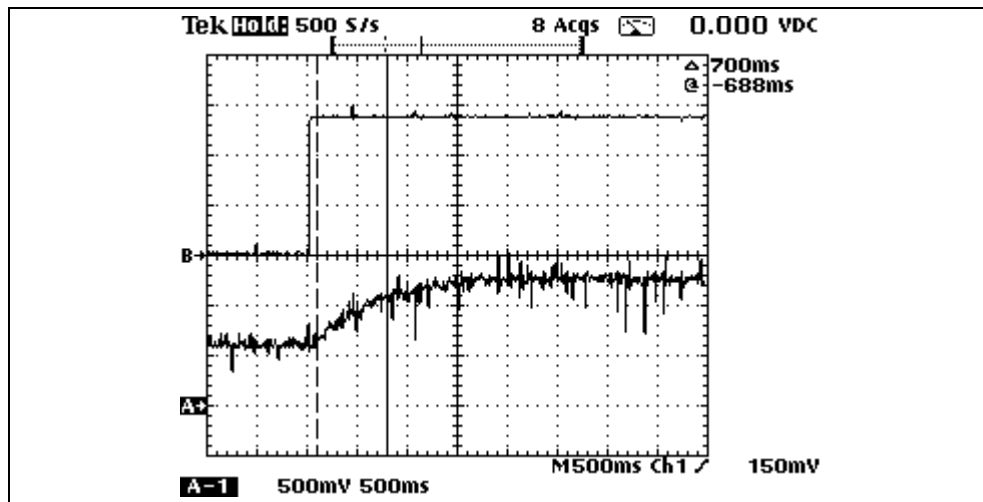

Figure 10-8 Response to 5 Hz step: T = 700 ms

The frequency step $\Delta f = 5 \text{ Hz} / 50 \text{ Hz} = 10 \%$
 The feedback step $\Delta x = 0.64 \text{ V} / 10 \text{ V} = 6.4 \%$

P gain = $(0.9)(T)(\Delta f) / (L)(\Delta x) = 9.84 = \mathbf{P2280}$

I time = $3L = 0.30 \text{ s} = \mathbf{P2285}$

The PI controller should now be enabled ($P2200 = 1$).

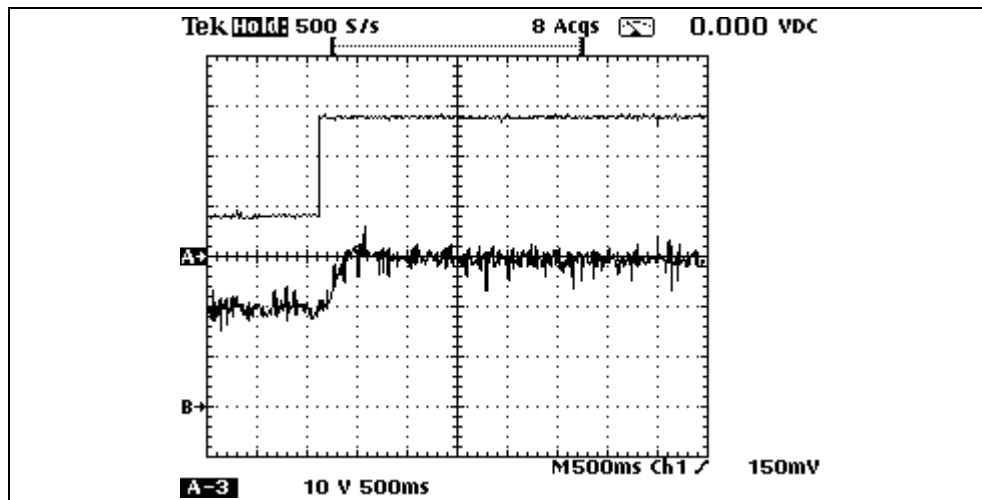

Figure 10-9 Step Response in PI control with P2280 = 9.84 and P2285 = 0.30

10.2.4 PI Output Limits

The PI controller generates the frequency at which the inverter runs. This is generated as a % which is normalized into Hz via P2000. The user can limit the output range of the controller using parameters P2291 and P2292. While the inverter will only operate within the frequency range defined by Fmin (P1080) and Fmax (P1082), the PI output limits can be used to further limit the output frequency. Once one of the limits has been reached a bit is set (P0053.A or P0053.B) which can be connected to the digital output via P0731, or used for internal control purposes using BiCo.

NOTE

If Fmax (P1082) is greater than the value in P2000, then either P2000 or P2291 should be adjusted to allow Fmax to be reached.

Setting P2292 to a negative value allows bipolar operation of the PI controller.

10.2.5 Further features

Further features, such as a PI setpoint trim can be accessed in user access level 3 (P0003 = 3). These features are described in the Parameter List.

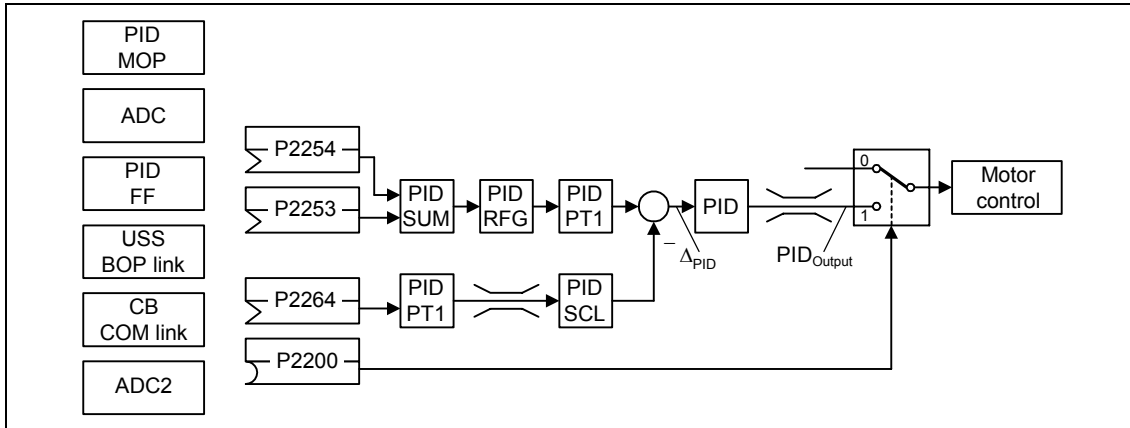

Figure 10-10 PI Basic Block Diagram

10.2.6 Energy Saving Mode

In order to enhance the lifetime of a system and reduce the energy consumption the energy saving modes (ESM) were implemented. For example, protection of the pump against overheating if the load valve is closed and no fluid is being pumped.

Should the inverter be required to restart having been powered off and on in Energy Saving Mode, it is necessary to activate the Auto-restart function of the inverter (using P1210=6).

NOTES

- Energy Saving Mode only operates in a positive direction.
- Energy Saving Setpoint must be greater than f_{min} .

10.2.6.1 Energy Saving Mode 1 (P2390 - P2392)

When the inverter under PID control drops below energy saving setpoint, the energy saving timer P2391 is started. When the energy saving timer has expired, the inverter is ramped down to stop and enters energy saving mode (see diagram below).

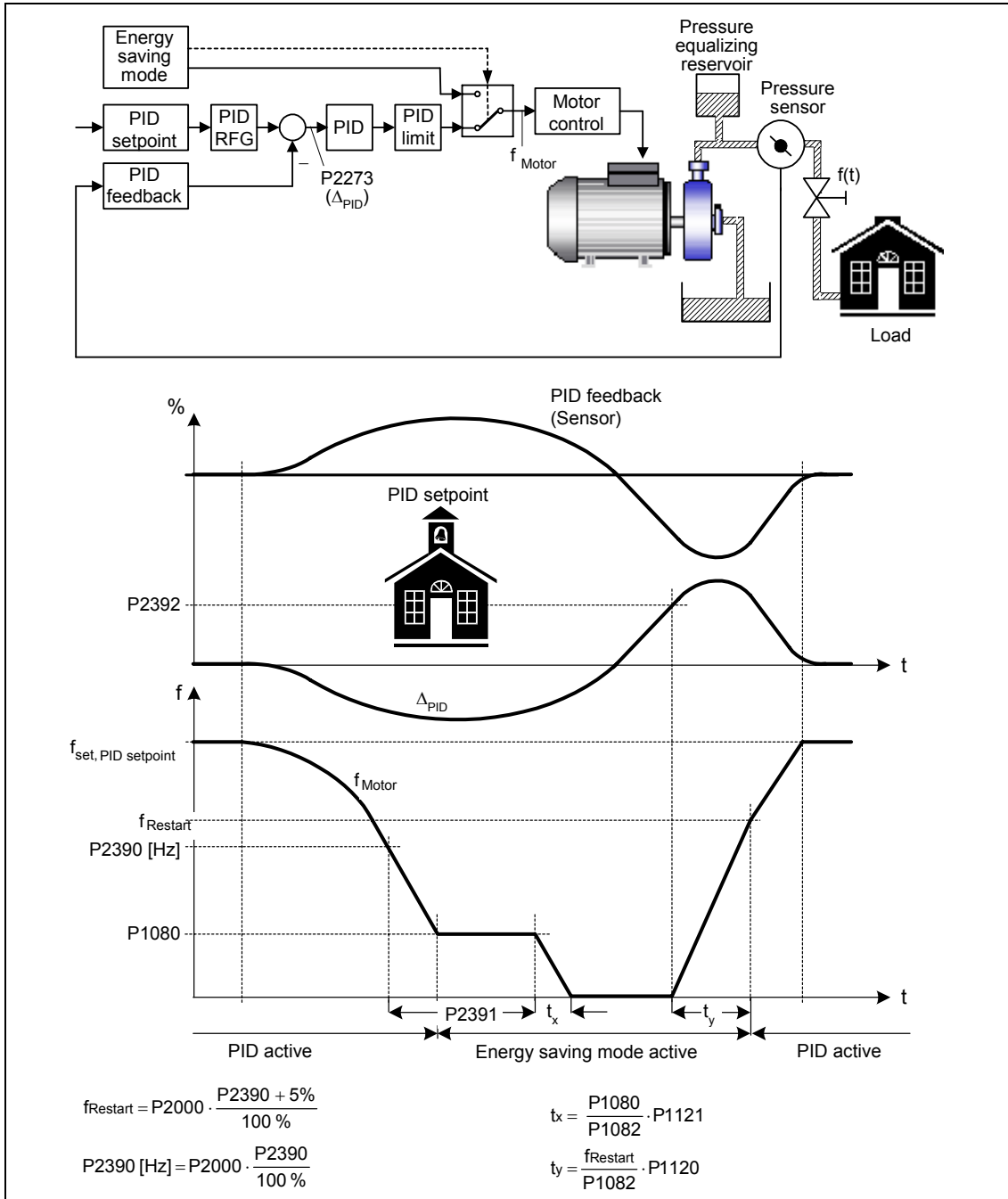

Figure 10-11 Energy Saving Mode 1

10.2.6.2 Energy Saving Mode 2 (P2393 - P2398)

Using the energy saving functionality, the control loop behavior is controlled so that the inverter recognizes that the load is reduced. In this case, the inverter will be shutdown if the actual value lies above the threshold p_x , which is defined by parameter P2393 and the setpoint p^* .

$$p_x = P2393 \cdot p^*$$

When the load decreases, this is recognized by the active current $r0086$, which is fed via the BICO-Parameter P2396 to a normalized characteristic.

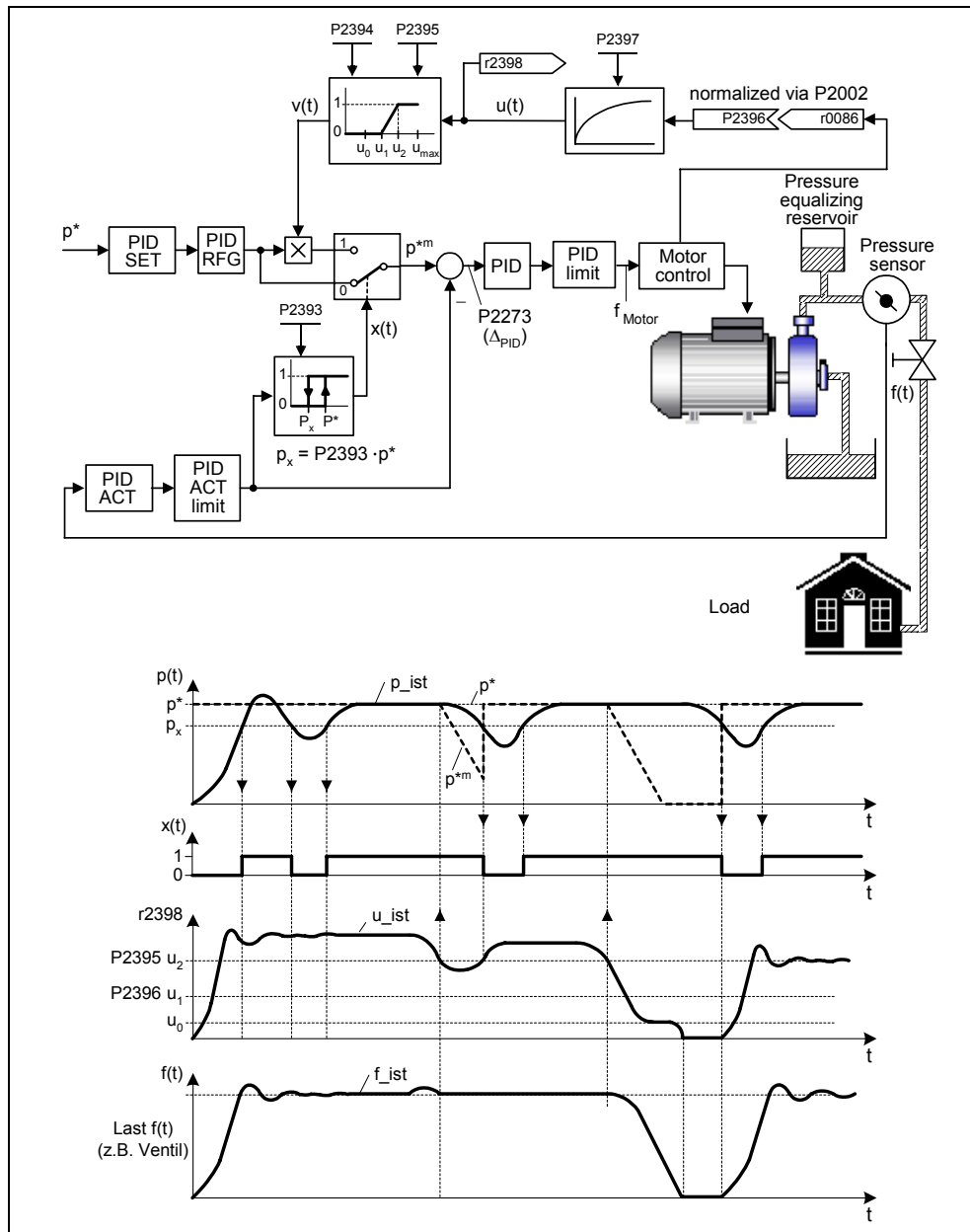

Figure 10-12 Energy Saving Mode 2

If the active current falls below the normalized threshold P2395, then the setpoint is linearly decreased as a function of the active current.

$$m = \frac{1}{P2395 - P2396}$$

This reduction causes the motor to be powered-down and in turn the system (e.g. pump), as long as the actual value (e.g. actual pressure) does not fall below the threshold px.

If the actual value falls below threshold px, while the setpoint is decreased via the active current, the decrease is stopped and the original setpoint p* is again re-established.

If the actual value falls below threshold px after the motor was shutdown, the inverter automatically powers-up again without having to toggle the ON command.

10.3 Braking

Reducing the output frequency of the inverter will cause the motor to slow down and as the frequency is gradually reduced to zero the motor will stop. Reducing the output frequency too rapidly may cause the motor to act as a generator and cause a negative current (regeneration) to return to the DC link. To overcome this possibility the MICROMASTER 411/COMBIMASTER 411 employs a number of methods to control braking. These options are described in the following paragraphs.

The method of bringing the motor to a standstill is selected by the user depending on operational requirements.

10.3.1 Normal Braking

The usual or normal braking method is to allow the motor to come to a standstill at the selected ramp-down rate (OFF1), to coast to a standstill (OFF2) or to quickly ramp down (OFF3) without applying any additional braking. (Refer to parameters P0701, P0702 and P0703). However, if regeneration does cause tripping, DC or Compound braking methods may be considered.

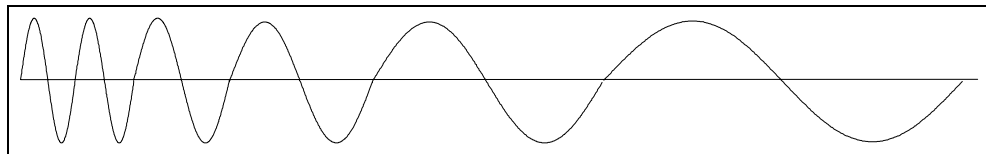

Figure 10-13 Frequency Ramp Down

10.3.2 DC Braking

In this method a controlled DC voltage is applied to the rotor. When using DC braking, the inverter output pulses are disabled and the actual time taken to bring the motor to a standstill cannot be predicted. Stored energy in the motor and the load is dissipated in the rotor therefore no regeneration occurs.

The DC braking current is defined as a percentage of nominal motor current using parameter P1232. The current will be applied only when the motor is sufficiently demagnetized. If the demagnetization time for the motor (P0347), is reduced too much then the drive will trip on over current (F0001) when DC braking is activated. DC braking can be enabled by an external source such as a digital input.

NOTE

The braking time depends on the rampdown time as follows.

$$\text{Braking time} = \text{Rampdown-time} * \frac{\text{P0305 (Motor rated current)}}{\text{r0207 (Inverter rated current)}}$$

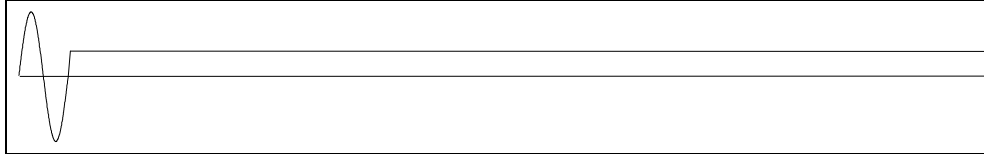

Figure 10-14 DC Braking

NOTE

Frequent use of DC Braking can cause the motor to overheat.

10.3.3 Vdc Max Controller

The MICROMASTER 411/COMBIMASTER 411 has a controller to limit the DC voltage (Vdc Max controller). When braking a load faster than would normally be possible, excess energy has to be dissipated. This energy is unable to go back into the input supply so the result is that the DC link voltage rises. If this voltage rises too high, the trip level will be reached and the output pulses disabled to prevent damage to the inverter. The Vdc Max controller automatically increases the frequency and extends the ramp down period so that the braking is not as fast, thus reducing the risk of an overvoltage trip and keeping the system running. This means that the system will ramp down on the voltage limit until a standstill or a new setpoint is reached. (Refer to Parameter P1240 for configuration details).

10.3.4 COMPOUND Braking

When Compound braking is used, most of the energy is dissipated in the motor instead of coming back into the DC link. This has the advantage that the braking performance of the inverter can be increased, without tripping the inverter and without the use of a braking resistor.

Compound braking combines the braking power of DC braking with the control offered by a ramp down. When using Compound braking, the ramp-down time is defined and the level of current to be used in Compound Braking is defined using P1236.

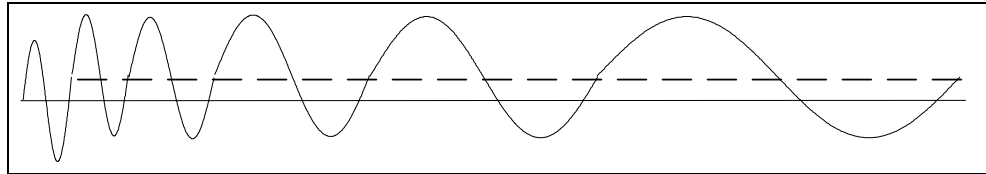

Figure 10-15 COMPOUND- Braking

10.4 Derating Factors

10.4.1 Derating with Temperature

Operation of the inverter outside its recommended ambient operating temperature would normally cause the inverter to trip with an overtemperature fault code. To avoid such tripping, the inverter automatically reduces its switching frequency (e.g. from 16 kHz to 8 kHz), thus reducing the temperature of the heatsink, enabling the application to continue running trip free. Should the load or ambient temperature then reduce, the inverter will first check to see if it is safe to increase the switching frequency again and if considered safe will then do so.

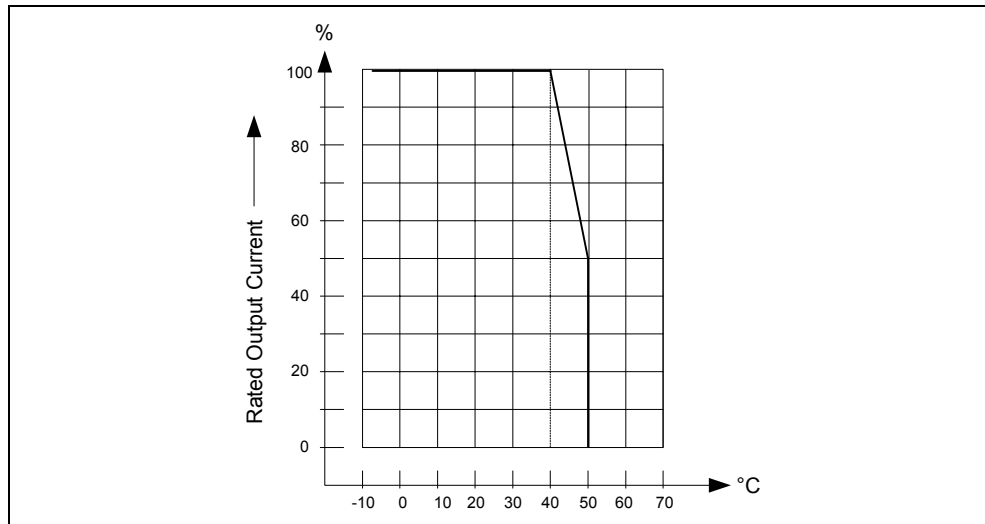

Figure 10-16 Derating with Temperature

10.4.2 Derating with Altitude

Figure 10-17 shows the permissible rated input voltage and output current for inverter installations from 500 m to 4000 m above sea level.

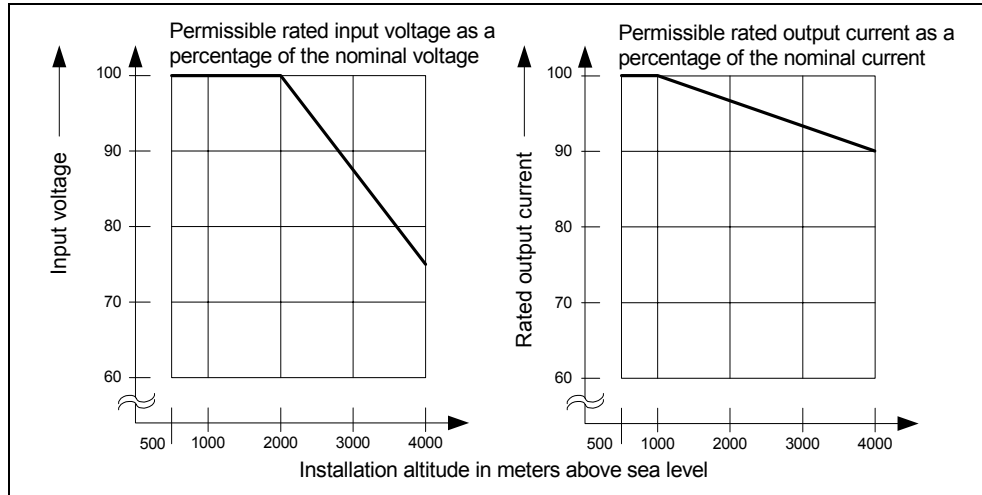

Figure 10-17 Derating with Altitude

10.4.3 Derating with Switching Frequency

The default switching frequency of the MICROMASTER 411/COMBIMASTER 411 is 4 kHz. This is usually adequate for most applications and will allow full performance to be obtained from all products over the full temperature range.

Select the switching frequency using P1800. High voltage units are automatically derated by reducing the continuous output current if switching frequencies above 4 kHz are selected. Deratings are shown at P1800 in the System Parameter list.

The switching frequency will be automatically reduced if the internal temperature of the inverter becomes too high (see r0037, inverter temperature). This reduces losses and allows continued operation. This feature is controlled by P0290.

Under extreme conditions of overload, the switching frequency may momentarily reduce to protect the inverter.

Derating applies to constant torque and variable torque settings. Table 10-3 shows the value to which the maximum outputs are reduced.

Table 10-3 Derating with Switching Frequencies

Power kW (hp)	Measured Output Current						
	4 kHz	6 kHz	8 kHz	10 kHz	12 kHz	14 kHz	16 kHz
0.37 (0.5)	1.2	1.2	1.2	1.2	1.2	1.2	1.2
0.55 (0.75)	1.6	1.6	1.6	1.6	1.6	1.6	1.2
0.75 (1.0)	2.1	2.1	2.1	2.1	1.8	1.8	1.2
1.10 (1.5)	3.0	3.0	2.7	2.7	1.8	1.8	1.2
1.50 (2.0)	4.0	4.0	2.7	2.7	1.8	1.8	1.2
2.20 (3.0)	5.9	5.9	5.1	5.1	3.5	3.5	2.3
3.00 (4.0)	7.7	7.7	5.1	5.1	3.5	3.5	2.3

10.4.4 Derating for Inverter Orientation

The inverter must not be mounted in an upside down orientation. Other mounting orientations are possible without derating.

10.5 Thermal Protection and Automatic De-rating

The MICROMASTER 411/COMBIMASTER 411 has comprehensive hardware and software thermal protection.

Hardware: Fitted to the heatsink is a PTC resistor that will cause the inverter to trip if the temperature reaches 95 °C.

Software: When the heatsink reaches a temperature of within 5°C of the trip level, the switching frequency and output frequency of the inverter will both be reduced. This reduces the Inverter losses and current and attempts to prevent an overtemperature trip.

It is possible to prevent this reduction and select an immediate trip if desired. See parameters P0290, P0292 for further details.

Instead of this reduction an immediate switching off also can be selected. More information see parameters P0290 and P0292

The inverter is further protected by an Inverter I²t calculation that determines how hot the Insulated Gate Bipolar Transistors (IGBTs) are and will reduce the current limit (P0640) when this calculation reaches 95%. (User defined in P0294). If the I²t continues to rise to 100% an Inverter I²t trip will occur (F0005).

Overtemperature in the inverter is usually caused by a high ambient temperature or blocked convection.

10.6 Operation from Unearthed Supplies

The MICROMASTER 411 cannot be used on unearthed input supplies.

10.7 Lifetime of Inverters

When the inverters are used in conjunction with Siemens motors (1LA7 and 1LA9) the lifetime of the inverter is > 20,000 hours.

10.8 Working with Binary Connectors (BiCo)

10.8.1 Introduction

To make use of BiCo you will need access to the full parameter list. At this level many new parameter settings are possible, including BiCo functionality. BiCo functionality is a more flexible way of setting and combining input and output functions. It can be used in most cases in conjunction with the simple, level 2 settings.

10.8.2 How does BiCo work?

The BiCo system, used on more complex drives such as Masterdrives, allows complex functions to be programmed. Boolean and mathematical relationships can be set up between inputs (digital, analogue, serial etc.) and outputs (inverter current, frequency, analogue output, relays etc.).

The MICROMASTER 411/COMBIMASTER 411 uses a simplified version of BiCo, (which is still very flexible) contained within the parameter set. The system can be set up without using additional software or hardware.

Example 1

Table 10-4 Use of BiCo parameterization to enable the output relay using Digital Input 2.

Step	Action
1	Set P0003 to 3 to access all parameters.
2	Set P0702 to 99 to enable BiCo parameterization on Digital Input 2. NOTE If P0701, 2, 3, or 4 are set to 99, it is not possible to change them to another value; the inverter must be reset to factory defaults.
3	Because Digital input 2 is 'open' to BiCo settings, a new value 722.1 now appears in P0731. The value 722.1 means 'connect to digital input 2' (722.0 = input 1, 722.2 = input 3 etc.). Set P0731 to 722.1
4	Run the inverter using input 1 and operate the relay using input 2.

NOTE

BiCo is a 'reverse' connection. That is, the output function is connected back to the input so it is not possible to tell from P0702 (99) what the digital input is controlling. However, there are many diagnostic parameters that can assist in setting up BiCo functions. (See following examples).

Example 2

Using OFF3 instead of OFF1.

Set P0701 = 99 to enable BiCo function.

Set P0840 = 722.0 (On right via digital input 1).

Set P0848 = 722.0 (OFF3 via digital input 1).

Now the inverter will ramp between set points using the normal ramp time as set in P1120 and 1121. However, at switch off from digital input 1, the inverter will turn off with an OFF3, using the ramp rate set in P1135, which may be different to P1121.

An additional advantage is that the OFF3 function usually requires a second digital input; here the BiCo function permits digital input 1 to perform a run right and an OFF3.

Example 3

Selecting an alternative ramp time when a certain fixed frequency is selected.

Three fixed frequencies are selected using three digital inputs.

The digital inputs also select 'on right'.

The third digital input also selects the alternative (Jog) ramp times.

NOTE

This will only enable an alternative ramp up time, because, when digital input 3 is switched low it will also de-select the alternative ramp time. Normal ramp down time will therefore be used.

Table 10-5 Select an alternative ramp up time (JOG)

Step	Definition	Action	Result
1	Use fixed frequencies.	P1000 = 3	
2	Enable BiCo functionality.	P0701 = 99 P0702 = 99 P0703 = 99	
3	Define source of Fixed Frequencies.	P1020 = 722.1 P1021 = 722.2 P1022 = 722.3	Defines the source of each fixed frequency as digital input 1, 2, and 3.
4	Define mode of operation.	P1016 = 2 P1017 = 2 P1018 = 2	Sets the mode of operation of fixed frequencies to "select fixed frequency and on right command".
5	Select Jog ramp times instead of normal ramp times.	P1124 = 722.2	Enables digital input 3.

NOTE

Steps 3 and 4 use BiCo functions to set digital input 1 and 2. This function can also be set using normal parameterization in Level 2.

10.8.3 Using Control and Status Words with BiCo

Many MICROMASTER 411/COMBIMASTER 411 read only parameters consist of control words. The parameter is made up of a 16-bit number, each bit representing a particular value. For example, parameter P0052 (Status Word 1) gives various value settings such as Inverter ready (bit 0), or Motor Current Limit (bit b).

This parameter is displayed using the vertical segments of the BOP display to show status; that is the status of each bit can be read from the BOP display. These bits can also be accessed by BiCo using the parameter number and bit state. Set parameter P0731 to 52.b (i.e. parameter P0052, bit b), for the relay to operate at current limit. This is actually a level 2 setting but many more settings can be selected in level 3 using BiCo functions.

Each bit of the control and status words (r0052 to r0056) can be connected to several output functions.

For example:

Setting P0731 to 56.5 (i.e. parameter P0056, bit 5) will indicate that starting boost is active. That is, if P1312 (Starting Boost) is set to enable some starting boost, the relay will be active during the ramping phase as starting boost is applied.

Similarly, if P0731 is set to 56.6, and P1311 (Acceleration Boost) enabled, the relay will be energized any time that the set point is changed.

Setting P0731 to 56.C would enable the relay when the Voltage Controller is active. As this occurs during regeneration it could be used to indicate excessive load, or too fast a ramp down.

Table 10-6 to Table 10-9 show the BiCo connections. The shaded/green boxes indicate the applicable cross connections.

10.8.4 BiCo Connections

Table 10-6 BiCo Connections (r0019 to r0054)

Parameter Number	Source	Name	Functional Grouping	CO/BO: BOP control word	CO: Frequency setpoint	CO: Act. frequency	CO: Act. output frequency	CO: Act. output voltage	CO: Act. DC-link voltage	CO: Act. output current	CO: Motor utilization	CO: Drive utilization	CO: Drive temperatures	CO: Power consumption [kWh]	CO/BO: Statusword 1	CO/BO: Statusword 2	CO/BO: Controlword 1
0731	CIB	BI: Binary output	7														
0800	CIB	BI: Download parameter set 0	7														
0801	CIB	BI: Download parameter set 1	7														
0840	CIB	BI: CDS Bit 0 (local/remote)	7														
0842	CIB	BI: ON/OFF1	7														
0844	CIB	BI: ON/OFF1 reverse	7														
0845	CIB	BI: 1. OFF2	7														
0848	CIB	BI: 2. OFF2	7														
0849	CIB	BI: 1. OFF3	7														
0852	CIB	BI: 2. OFF3	7														
1020	CIB	BI: Pulse enable	7														
1021	CIB	BI: Fixed frequency selection bit 0	7														
1022	CIB	BI: Fixed frequency selection bit 1	7														
1032	CIB	BI: Fixed frequency selection bit 2	7														
1035	CIB	BI: Enable MOP (UP-command)	7														
1036	CIB	BI: Enable MOP (DOWN-command)	7														
1055	CIB	BI: Enable JOG right	7														
1056	CIB	BI: Enable JOG left	7														
1074	CIB	BI: Disable additional setpoint	7														
1110	CIB	BI: Inhibit reverse direction	7														
1113	CIB	BI: Reverse	7														
1124	CIB	BI: Enable JOG ramp times	7														
1140	CIB	BI: RFG enable	7														
1141	CIB	BI: RFG start	7														
1142	CIB	BI: RFG enable setpoint	7														
1230	CIB	BI: Enable DC braking	7														
2103	CIB	BI: 1. Faults acknowledgement	7														
2104	CIB	BI: 2. Faults acknowledgement	7														
2106	CIB	BI: External fault	7														
2220	CIB	BI: Fixed PID setpoint selection bit	7														
2221	CIB	BI: Fixed PID setpoint selection bit	7														
2222	CIB	BI: Fixed PID setpoint selection bit	7														
2235	CIB	BI: Enable MOP (UP-command)	7														
2236	CIB	BI: Enable MOP (DOWN-command)	7														
0771	CIW	CI: DAC	8														
1070	CID	CI: Main setpoint	10														
1071	CIF	CI: Main setpoint scaling	10														
1075	CID	CI: Additional setpoint	10														
1076	CIF	CI: Additional setpoint scaling	10														
2016	CIW	CI: PZD to BOP-Link (USS)	20														
2019	CIW	CI: PZD to Comm-Link (USS)	20														
2051	CIW	CI: PZD to CB	20														
2200	CIB	BI: Enable PID controller	22														
2253	CIF	CI: PID setpoint	22														
2254	CIF	CI: PID trim source	22														
2264	CIF	CI: PID feedback	22														

Table 10-7 BiCo Connections (r0055 to r1119)

Parameter Number	Source	Name	Functional Grouping	COBO	COBO	CO	CO	CO	COBO	COBO	CO	CO	CO	CO	CO	CO	CO
ParNr	BiCo			0055	0056	0067	0071	0086	0722	0747	0755	1024	1050	1078	1079	1114	1119
				CO/BO: Controlword 2	CO/BO: Statusword 1 for V/F and VC	CO: Act. max. current	CO: Max. output voltage	CO: Act. active current	CO/BO: Binary input values	CO/BO: State of binary outputs	CO: Act. ADC characteristic value I40	CO: Act. fixed frequency	CO: Output frequency of the MOP	CO: Total frequency setpoint	CO: Selected frequency setpoint	CO: Frequency setpoint after DIR ctrl	CO: Frequency setp. of the AFM module
0731	CIB	BI: Binary output	7														
0800	CIB	BI: Download parameter set 0	7														
0801	CIB	BI: Download parameter set 1	7														
0840	CIB	BI: CDS Bit 0 (local/remote)	7														
0842	CIB	BI: ON/OFF1	7														
0844	CIB	BI: ON/OFF1 reverse	7														
0845	CIB	BI: 1. OFF2	7														
0848	CIB	BI: 2. OFF2	7														
0849	CIB	BI: 1. OFF3	7														
0852	CIB	BI: 2. OFF3	7														
1020	CIB	BI: Pulse enable	7														
1021	CIB	BI: Fixed frequency selection bit 0	7														
1022	CIB	BI: Fixed frequency selection bit 1	7														
1032	CIB	BI: Fixed frequency selection bit 2	7														
1035	CIB	BI: Enable MOP (UP-command)	7														
1036	CIB	BI: Enable MOP (DOWN-command)	7														
1055	CIB	BI: Enable JOG right	7														
1056	CIB	BI: Enable JOG left	7														
1074	CIB	BI: Disable additional setpoint	7														
1110	CIB	BI: Inhibit reverse direction	7														
1113	CIB	BI: Reverse	7														
1124	CIB	BI: Enable JOG ramp times	7														
1140	CIB	BI: RFG enable	7														
1141	CIB	BI: RFG start	7														
1142	CIB	BI: RFG enable setpoint	7														
1230	CIB	BI: Enable DC braking	7														
2103	CIB	BI: 1. Faults acknowledgement	7														
2104	CIB	BI: 2. Faults acknowledgement	7														
2106	CIB	BI: External fault	7														
2220	CIB	BI: Fixed PID setpoint selection bit	7														
2221	CIB	BI: Fixed PID setpoint selection bit	7														
2222	CIB	BI: Fixed PID setpoint selection bit	7														
2235	CIB	BI: Enable MOP (UP-command)	7														
2236	CIB	BI: Enable MOP (DOWN-command)	7														
0771	CIW	CI: DAC	8														
1070	CID	CI: Main setpoint	10														
1071	CIF	CI: Main setpoint scaling	10														
1075	CID	CI: Additional setpoint	10														
1076	CIF	CI: Additional setpoint scaling	10														
2016	CIW	CI: PZD to BOP-Link (USS)	20														
2019	CIW	CI: PZD to Comm-Link (USS)	20														
2051	CIW	CI: PZD to CB	20														
2200	CIB	BI: Enable PID controller	22														
2253	CIF	CI: PID setpoint	22														
2254	CIF	CI: PID trim source	22														
2264	CIF	CI: PID feedback	22														

Table 10-8 BiCo Connections (r1170 to r2050)

Parameter Number	Source	Name	Functional Grouping	1170	1242	1337	1343	1344	1801	2015	2016	2018	2032	2033	2036	2037	2050
ParNr	BiCo			CO	CO	CO	CO	CO	CO	CO	CIW	CO	BO	BO	BO	BO	CO
0731	CIB	BI: Binary output	7														
0800	CIB	BI: Download parameter set 0	7														
0801	CIB	BI: Download parameter set 1	7														
0840	CIB	BI: CDS Bit 0 (local/remote)	7														
0842	CIB	BI: ON/OFF1	7														
0844	CIB	BI: ON/OFF1 reverse	7														
0845	CIB	BI: 1. OFF2	7														
0848	CIB	BI: 2. OFF2	7														
0849	CIB	BI: 1. OFF3	7														
0852	CIB	BI: 2. OFF3	7														
1020	CIB	BI: Pulse enable	7														
1021	CIB	BI: Fixed frequency selection bit 0	7														
1022	CIB	BI: Fixed frequency selection bit 1	7														
1032	CIB	BI: Fixed frequency selection bit 2	7														
1035	CIB	BI: Enable MOP (UP-command)	7														
1036	CIB	BI: Enable MOP (DOWN-command)	7														
1055	CIB	BI: Enable JOG right	7														
1056	CIB	BI: Enable JOG left	7														
1074	CIB	BI: Disable additional setpoint	7														
1110	CIB	BI: Inhibit reverse direction	7														
1113	CIB	BI: Reverse	7														
1124	CIB	BI: Enable JOG ramp times	7														
1140	CIB	BI: RFG enable	7														
1141	CIB	BI: RFG start	7														
1142	CIB	BI: RFG enable setpoint	7														
1230	CIB	BI: Enable DC braking	7														
2103	CIB	BI: 1. Faults acknowledgement	7														
2104	CIB	BI: 2. Faults acknowledgement	7														
2106	CIB	BI: External fault	7														
2220	CIB	BI: Fixed PID setpoint selection bit	7														
2221	CIB	BI: Fixed PID setpoint selection bit	7														
2222	CIB	BI: Fixed PID setpoint selection bit	7														
2235	CIB	BI: Enable MOP (UP-command)	7														
2236	CIB	BI: Enable MOP (DOWN-command)	7														
0771	CIW	CI: DAC	8														
1070	CID	CI: Main setpoint	10														
1071	CIF	CI: Main setpoint scaling	10														
1075	CID	CI: Additional setpoint	10														
1076	CIF	CI: Additional setpoint scaling	10														
2016	CIW	CI: PZD to BOP-Link (USS)	20														
2019	CIW	CI: PZD to Comm-Link (USS)	20														
2051	CIW	CI: PZD to CB	20														
2200	CIB	BI: Enable PID controller	22														
2253	CIF	CI: PID setpoint	22														
2254	CIF	CI: PID trim source	22														
2264	CIF	CI: PID feedback	22														

Table 10-9 BiCo Connections (r2053 to r2294)

Parameter Number	Source	Name	Functional Grouping	CO	CO	BO	BO	COBO	CO	CO	CO	CO	CO	CO	CO	
ParNr	BiCo			2053	2054	2090	2091	2197	2224	2250	2260	2262	2266	2272	2273	2294
				CO: CB identification	CO: CB diagnosis	BO: ControlWord 1 from CB	BO: Controlword 2 from CB	CO/BO: Statusword 1 of monitor	CO: Act. fixed PID setpoint	CO: Output setpoint of the MOP	CO: PID setpoint	CO: PID filtered setpoint	CO: PID feedback	CO: PID scaled feedback	CO: PID error	CO: PID output
0731	CIB	BI: Binary output	7													
0800	CIB	BI: Download parameter set 0	7													
0801	CIB	BI: Download parameter set 1	7													
0840	CIB	BI: CDS Bit 0 (local/remote)	7													
0842	CIB	BI: ON/OFF1	7													
0844	CIB	BI: ON/OFF1 reverse	7													
0845	CIB	BI: 1. OFF2	7													
0848	CIB	BI: 2. OFF2	7													
0849	CIB	BI: 1. OFF3	7													
0852	CIB	BI: 2. OFF3	7													
1020	CIB	BI: Pulse enable	7													
1021	CIB	BI: Fixed frequency selection bit 0	7													
1022	CIB	BI: Fixed frequency selection bit 1	7													
1032	CIB	BI: Fixed frequency selection bit 2	7													
1035	CIB	BI: Enable MOP (UP-command)	7													
1036	CIB	BI: Enable MOP (DOWN-command)	7													
1055	CIB	BI: Enable JOG right	7													
1056	CIB	BI: Enable JOG left	7													
1074	CIB	BI: Disable additional setpoint	7													
1110	CIB	BI: Inhibit reverse direction	7													
1113	CIB	BI: Reverse	7													
1124	CIB	BI: Enable JOG ramp times	7													
1140	CIB	BI: RFG enable	7													
1141	CIB	BI: RFG start	7													
1142	CIB	BI: RFG enable setpoint	7													
1230	CIB	BI: Enable DC braking	7													
2103	CIB	BI: 1. Faults acknowledgement	7													
2104	CIB	BI: 2. Faults acknowledgement	7													
2106	CIB	BI: External fault	7													
2220	CIB	BI: Fixed PID setpoint selection bit	7													
2221	CIB	BI: Fixed PID setpoint selection bit	7													
2222	CIB	BI: Fixed PID setpoint selection bit	7													
2235	CIB	BI: Enable MOP (UP-command)	7													
2236	CIB	BI: Enable MOP (DOWN-command)	7													
0771	CIW	CI: DAC	8													
1070	CID	CI: Main setpoint	10													
1071	CIF	CI: Main setpoint scaling	10													
1075	CID	CI: Additional setpoint	10													
1076	CIF	CI: Additional setpoint scaling	10													
2016	CIW	CI: PZD to BOP-Link (USS)	20													
2019	CIW	CI: PZD to Comm-Link (USS)	20													
2051	CIW	CI: PZD to CB	20													
2200	CIB	BI: Enable PID controller	22													
2253	CIF	CI: PID setpoint	22													
2254	CIF	CI: PID trim source	22													
2264	CIF	CI: PID feedback	22													

10.9 Harmonic Currents

Harmonic currents with 1% mains impedance

Table 10-10 Three Phase 400 V Connection

MLFB	Filter Type	Power CT (kW)	Fundamental Amps	5th Amps	7th Amps	11th Amps	13th Amps	17th Amps	19th Amps
6SE6411-6UD13-7AA1	unfiltered	0.37	1.50	1.29	1.10	0.67	0.46	0.15	0.09
6SE6411-6BD13-7AA1	Class B								
6SE6411-6UD15-5AA1	unfiltered	0.55	2.00	1.69	1.42	0.79	0.51	0.14	0.11
6SE6411-6BD15-5AA1	Class B								
6SE6411-6UD17-5AA1	unfiltered	0.75	2.60	2.13	1.75	0.87	0.51	0.13	0.15
6SE6411-6BD17-5AA1	Class B								
6SE6411-6UD21-1AA1	unfiltered	1.1	3.71	2.98	2.35	1.05	0.53	0.18	0.22
6SE6411-6BD21-1AA1	Class B								
6SE6411-6UD21-5AA1	unfiltered	1.5	4.92	3.80	2.95	1.11	0.49	0.26	0.28
6SE6411-6BD21-5AA1	Class B								
6SE6411-2UD22-2AA1	unfiltered	2.2	7.89	7.01	6.18	4.19	3.11	1.30	0.60
6SE6411-6BD22-2AA1	Class B								
6SE6411-2UD23-0AA1	unfiltered	3	10.09	8.69	7.69	4.68	3.45	1.05	0.39
6SE6411-6BD23-0AA1	Class B								

10.10 Use of MICROMASTER 4 Input Chokes

When the inverter is operating it gives rise to a non-sinusoidal current from the mains supply with harmonics. The amplitude of the harmonics can be reduced by fitting input chokes.

When the mains supply impedance is less than 1% it is necessary to use an input choke with the inverter. It is recommended to use the standard MM4 range of input chokes, details of which can be obtained from the DA51.2 Catalogue. The choke must be housed in a mechanical enclosure appropriate to the environment.

Mains Supply Impedance

This is the ratio of the inverter rated power to mains short-circuit power. If the mains supply impedance is below 1%, the lifetime of the electrolytic capacitors could be reduced.

The mains short-circuit power may be obtained from the power supply company, or may be read from the Type Plate of the supplying power transformer.

10.11 Power Losses

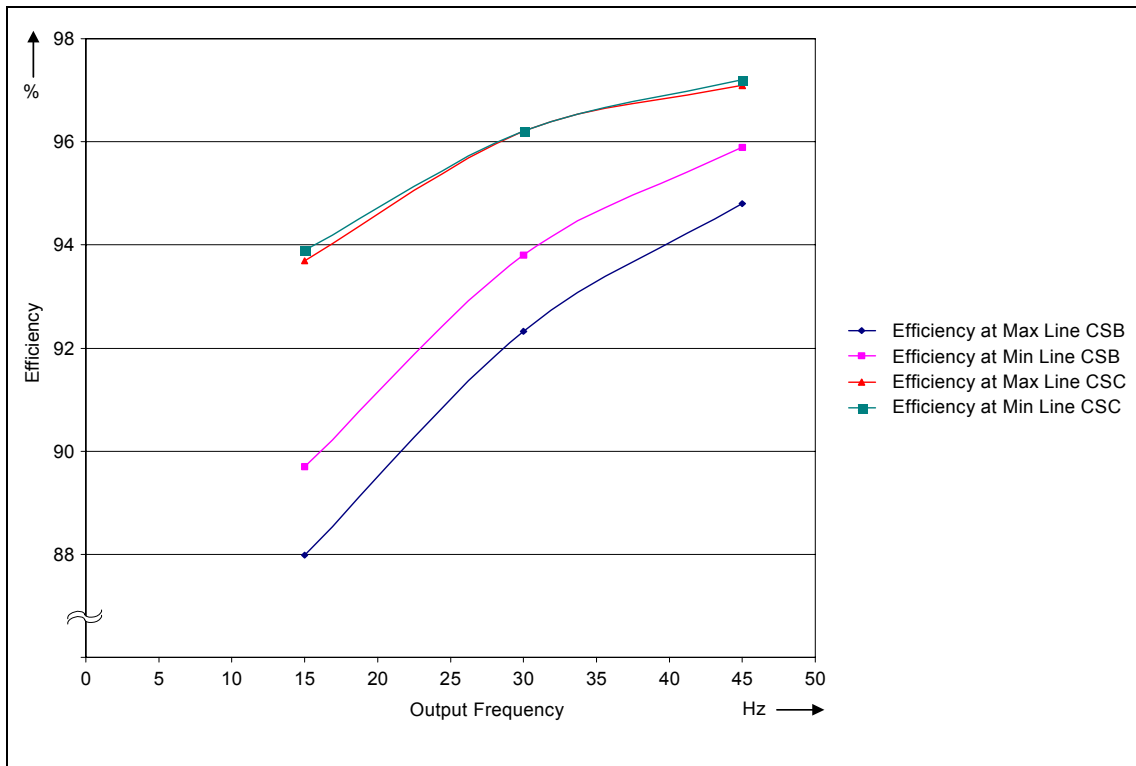

Figure 10-18 Power Losses MICROMASTER 411 / COMBIMASTER 411

10.12 Shock and Vibration

The inverter has been tested for compliance with the following standards.

10.12.1 Vibration Stress during Operation (Single Sine Sweep)

Required Standards: EN 60721-3-3 class 3M6 and 3M8

Test standards: EN60068-2-6, test Fc

Case Size B: Class 3M6: 10-58 Hz/ 0.15 mm, 58-200 Hz/ 2g

Case Size C: Class 3M6: 10-58 Hz/ 0.15 mm, 58-200 Hz/ 2g

10.12.2 Shock Stress during Operation (Half Sine Shock)

Required Standards: EN 60721-3-3

Test standards: EN 60068-2-27, test Ea

Case Size B: Peak acceleration 5g - duration of shock 30 ms

Case Size C: Peak acceleration 5g - duration of shock 30 ms

10.12.3 Vibration and Shock stress during Transport

Required Standards: EN 60721-3-3

Test standards: EN 60068-2-27, Test Ea

Class 2M2: 5-9 Hz/ 3.5 mm, 9-200 Hz/ 1g

Class 2M1: Peak acceleration 15g - duration of shock 11 ms.

The inverter meets class 2M2 for Vibration stress and 2M1 for shock stress in product packaging.

10.13 PROFIBUS

Overview

PROFIBUS is an open standard communication protocol which has been designed and developed for use in general industrial applications. The standard is defined in EN50170 (volume 2) and has been developed, agreed and adopted by many manufacturers worldwide.

PROFIBUS control is now available for a wide variety of products, from many different companies manufacturing drives, actuators, valves, as well as Programmable Logic Controllers (PLCs) and other system controllers. PROFIBUS operates over a variety of hardware interconnections such as fiber optics and RS485.

There are three versions of PROFIBUS: FMS, DP and PA and all these versions will work together. The most commonly used version is the DP version, intended for general industrial applications. This is the version supported by Siemens Drives.

Using the PROFIBUS

In order to connect to a PROFIBUS system, a PROFIBUS module is required. This module mounts on the side of the drive and uses a TTL serial port to communicate with the drive.

The drive may be controlled and monitored via the main PROFIBUS system.

A PROFIBUS system offers the following advantages:

- Open, clearly defined system.
- Many different products from many different manufacturers.
- Well proven in many industrial applications.
- Reduced wiring; easy set up re-programming, monitor and control.
- Ease of commissioning with the SIMATIC S7 PLC System at a later date.
- Flexibility to expand and modify the automatic system at a later date.
- Remote diagnostics reduce the downtime in the event of a problem.
- Very fast; up to 12 Mbaud.
- Up to 125 slaves on one DP system.
- Single or Multi-master operation.
- One to one or broadcast communications.
- Support and development software available.
- Routing Functionality

10.13.1 PROFIBUS Module

This option allows the MICROMASTER 411/COMBIMASTER 411 to be controlled via a PROFIBUS-DP serial bus (SINEC L2-DP).

PROFIBUS-DP is a cost-effective high-speed serial communication system optimized for the actuator/sensor area where very short system reaction times are critical. It operates as a decentralized I/O system whereby the traditional wiring to sensors and actuators is replaced by an RS485 serial bus system linking the stations together.

The suitability of the system for such applications has been enhanced by an extension of the bus speed up to 12 MBd. Protocol is defined as DIN19245 and also as EN50170 guaranteeing open, multi-vendor communications between PROFIBUS-DP stations.

Up to 125 stations can be networked together using this single bus system and a very flexible data structure allows the system to be optimized to exactly match the requirements of each device.

PROFIBUS-DP lies at the heart of the new generation of SIMATIC S7 automation systems offered by Siemens. Using this single bus system, all engineering, visualization and PLC control operations can be integrated. To configure a SIMATIC based automation system, all that is required is the associated STEP7 configuration tool running on a PC. Bus configuration is performed by using a drag and drop technique in a graphically displayed PROFIBUS-DP network.

10.13.2 Features of PROFIBUS Module

Overview

- Permits fast cyclic communications via a PROFIBUS connection.
- Supports all PROFIBUS baud rates up to 12 MBd.
- Control of up to 125 inverters using PROFIBUS-DP protocol (with repeaters).
- Conforms to EN50170 guaranteeing open communications on a serial bus system. It can be used with other PROFIBUS-DP/SINEC L2-DP peripheral devices on the serial bus. Data format conforms to the VDI/VDE directive 3689 "PROFIBUS Profile for Variable Speed Drives".
- Acyclic communications channel for connecting SIMOVIS or other service tools.
- Support for the PROFIBUS control commands SYNC and FREEZE.
- Can be easily configured using the S7 Manager software, or any proprietary PROFIBUS commissioning tool.
- Simple integration into a SIMATIC S7 PLC system using specially designed software modules (S7).

- Module can be powered by external +24 V Power Supply if required.
 - No separate power supply necessary.
 - Digital and analog inputs can be read and digital output is controlled via the serial bus.
 - 5 msec response time to process data.
 - Output frequency (and therefore motor speed) can be controlled locally on the drive or over the serial bus.
 - Multi-mode operation possible, whereby control data can be input via the terminal block (digital inputs) and setpoint over the serial bus. Alternatively, the setpoint can be from a local source (analogue input) with the drive control over the serial bus.
- Inverter parameters are accessible over the serial link.

NOTES

The PROFIBUS Module (see Section 8.4) can only be fitted and removed from the inverter when the inverter is powered off.

The PROFIBUS Module must be connected to the drive using the cable supplied.

Data structure

The data structure for communication over PROFIBUS-DP can be either PPO type 1 or PPO type 3 as specified in VDI/VDE 3689. This means in practice that process data (control words, setpoints in the transmitted telegram and status words, actual values in the received telegram) are always sent. Parameter data exchange may, however, be blocked if bus bandwidth or PLC memory space is at a premium. The data structure, and thus the PPO type, is normally specified by the bus master. If no PPO type is specified (e.g. if a combined PROFIBUS DP/PROFIBUS FMS bus master is used), the default PPO type is type 1 (parameter data exchange enabled).

Process data from the serial link always has a higher priority than parameter data. This means that a setpoint change or drive control change command will be processed faster than a parameter change command.

Access to the parameters

Parameter write access over the serial link can be enabled or blocked as required. Parameter read access is permanently enabled, allowing continuous read-out of drive data, diagnostics, fault messages etc. A visualization system can thus be realized with minimal effort.

Local control of the drive with the On, Off, Jog and Reverse buttons is possible at all times in an identical fashion to when the module is not present.

Connection data

PROFIBUS cables are connected to terminals within the Module. Cables are fed into the module via cable glands.

Table 10-11 Maximum Cable Lengths for Data Transfer Rates

Data transfer rate (Kbit/s)	Max. cable length of a segment (m)
9.60	1200
19.20	1200
93.75	1200
187.50	1000
500.00	400
500.00	200
12000.00	100

The shield of the cable must be connected to the housing of the PROFIBUS Module (i.e., recommended use of metal cable glands for this purpose).

A segment can be extended by using RS485 repeaters.

Recommendation: SINEC L2 repeater RS485 (Order No: 6ES7972-0AA00-0XA0).

For reliable operation of the serial bus system, the cable must be terminated at both ends using terminating resistors. Bus terminations with the MICROMASTER 411 PROFIBUS Module is achieved using the Bus Termination Switch (see above). Additionally, for 12 MBd operation, no stub length from the main bus cable is allowed.

Quick Guide to setting up PROFIBUS

- The bus cable between the master device and the drive must be connected correctly. this includes the necessary termination resistors.
- Bus Termination within the PROFIBUS module can be achieved using the termination switch (SW1).
- The bus cable must be screened and the screen must be connected to the housing of the cable connector.
- The PROFIBUS master must be configured correctly so that communications can be realized with a DP slave using PPO type 1 or PPO type 3 (only PPO type 1, if the PPO type cannot be configured via remote operator control).

Installation should be in conformance with EMC directives and regulations (this is described in detail in the operating manuals for the drive and the PLC).

Table 10-12 Technical data – 411 PROFIBUS Module

Item	Description
Dimensions H x W x D	107,8 mm x 128 mm x 40,5 mm
Degree of protection	IP66
Maximum bus speed	12 MBaud

Table 10-13 PROFIBUS Ordering information

Designation	Order No.
PROFIBUS module	6SE6401-1PB00-0AA00

10.14 Variant Independent Options

Several options are available for use with Siemens Standard inverters. These are intended to assist product selection, installation and commissioning in certain applications.

10.14.1 Basic Operating Panel (BOP)

MICROMASTER default settings can be changed through the Basic Operator Panel (BOP) drive option. The BOP provides direct access to the MICROMASTER 411 operating parameters. Speed, frequency, motor direction, current and torque values can all be accessed and displayed. The BOP has the capacity to actively interface with the parameter sets stored in the drive. The BOP consists of a keypad control panel array and a 5-digit LCD display with backlight. Available in hand held or panel-mounted form the unit provides a visual interface with the inverter control. Access to internal parameters and functions is achieved from the pushbutton set on the panel fascia. Navigational push-buttons are provided for movement through parameters and values.

10.14.2 Advanced Operating Panel (AOP)

The Advanced Operator Panel (AOP) enhances the interface/communication capability of the MICROMASTER range of frequency inverters. Available in either Desk or Panel mounted form the unit provides the user with an intelligent, clear text inverter interface. This gives direct access to the control, programming, storage and monitoring of MICROMASTER series operating parameters.

For local control of individual inverters the AOP is mounted into a Desk Mount platform.

Each unit supports software capable of carrying out configuration and storage of inverter parameter sets. Software menus, inverter parameters, associated values and help text is displayed on a compact dot matrix LCD screen. Operator commands for software are derived from a keypad located directly below the LCD screen. Communication with dependent inverters is achieved via RS232 interface terminals.

Summary:

The AOP has several practical uses. For example:

The AOP can be mounted on a Door Mount Kit (using an optional cable of up to 5 m) to enable remote control and monitoring of the inverter.

The AOP can be used to allow for communication with a PC.

Parameter sets can be stored in the AOP and uploaded or downloaded as required. Particularly useful where many inverters require programming in production.

10.14.3 PROFIBUS Module

The PROFIBUS module allows full PROFIBUS connection of up to 12 Mbaud. You can supply the module from an external 24 V supply which keeps PROFIBUS active even when the inverter is removed from its power. The module permits full remote control of PROFIBUS or local control or a mixture of both.

10.14.4 PC to Inverter Connection Kit

The PC to Inverter Connection Kit is used for controlling an inverter directly from a PC provided the correct software has been installed. The hardware includes an opto-isolated RS232 adapter board and a RS232 Serial Comms cable for reliable point-to-point connection.

10.14.5 BOP/AOP Door Mounting Kit for Single Inverter Control

This kit is used to mount an operator panel in a cabinet door. It must be used in conjunction with a MICROMASTER 411 5 m cable assembly. The connecting line must be supplied by the user.

This kit extends the existing RS232 interface, bringing connections and power from the interface connector to terminals, which can then be wired to the AOP or BOP mounted in the door. Although RS232 should be limited to 3 m of cable, up to 20 m of cable can operate satisfactorily, but this is not guaranteed.

10.14.6 EM Module

The EM Brake Module is used to provide an output to the drive coil of a DC electromechanical motor brake. The brake output can be software configured for fast and slow coil operation.

The coil voltages of the respective motor brakes are listed in the EM Brake Module Operating Instructions.

Details on the module can be found in the associated operating instructions.

10.14.7 REM Module

The optional REM Module (Resistor and Electromechanical Brake Control Module) is used to support „slow down“ of the motor and protect against regenerative feedback to the inverter from the motor as well as to control an electromechanical brake, mounted on the motor. It combines an EM brake functionality with an resistor brake functionality.

Details on the module can be found in the associated operating instructions.

Appendices

A.1 Applicable Standards



European Low Voltage Directive

The MICROMASTER product range complies with the requirements of the Low Voltage Directive 73/23/EEC as amended by Directive 98/68/EEC. The units are certified for compliance with the following standards:

EN 60146-1-1	Semiconductor inverters – General requirements and line commutated inverters
EN 60204-1	Safety of machinery – Electrical equipment of machines

European Machinery Directive

The MICROMASTER product range does not fall under the scope of the Machinery Directive. However, the products have been fully evaluated for compliance with the essential Health & Safety requirements of the directive when used in a typical machine application. A Declaration of Incorporation is available on request.

European EMC Directive

When installed according to the recommendations described in this manual, the MICROMASTER product range fulfils all requirements of the EMC Directive as defined by the EMC Product Standard for Power Drive Systems EN61800-3.

ISO 14001

Siemens plc operates a quality and environmental management system, which complies with the requirements of ISO 14001.

ISO 9001

Siemens plc operates a quality management system, which complies with the requirements of ISO 9001.



Underwriters Laboratories

UL certification is presently in process.

A.2 List of Abbreviations

AC	Alternating current	FSA	Frame size A
AD	Analog digital converter	GSG	Getting started guide
ADC	Analog digital converter	GUI ID	Global unique identifier
ADR	Address	HIW	Main actual value
AFM	Additional frequency modification	HSW	Main setpoint
AG	Automation unit	HTL	High-threshold logic
AIN	Analog input	I/O	Input and output
AOP	Advanced operator panel	IBN	Commissioning
AOUT	Analog output	IGBT	Insulated gate bipolar transistor
ASIC	Application-specific integrated circuit	IND	Sub-index
ASP	Analog setpoint	JOG	Jog
ASVM	Asymmetric space vector modulation	KIB	Kinetic buffering
AWG	American Wire Gauge	LCD	Liquid crystal display
BCC	Block check character	LED	Light emitting diode
BCD	Binary-coded decimal code	LGE	Length
BI	Binector input	MHB	Motor holding brake
BICO	Binector / connector	MM4	MICROMASTER 4th. Generation
BIST	Test program	MOP	Motor potentiometer
BO	Binector output	NC	Normally closed
BOP	Basic operator panel	NO	Normally open
C	Commissioning	NPN	Negative positive negative
CB	Communication board	OPI	Operating instructions
CCW	Counter-clockwise	PDS	Power drive system
CDS	Command data set	PID	PID controller (proportional, integral, derivative)
CI	Connector input	PKE	Parameter ID
CM	Configuration management	PKW	Parameter ID value
CMD	Commando	PLC	Programmable logic controller
CMM	Combimaster	PLI	Parameter list
CO	Connector output	PNP	Positive negative positive
CO/BO	Connector output / Binector output	POT	Potentiometer
COM	Common (terminal that is connected to NO or NC)	PPO	Parameter process data object
COM-Link	Communication link	PTC	Positive temperature coefficient
CT	Commissioning, ready to run	PWE	Parameter value
CT	Constant torque	PWM	Pulse-width modulation
CUT	Commissioning, run, ready to run	PX	Power extension
CW	Clockwise	PZD	Process data
DA	Digital analog converter	QC	Quick commissioning
DAC	Digital analog converter	RAM	Random-access memory
DC	Direct current	RCCB	Residual current circuit breaker
DDS	Drive data set	RCD	Residual current device
DIN	Digital input	RFG	Ramp function generator
DIP	DIP switch	RFI	Radio-frequency interference
DOUT	Digital output	RPM	Revolutions per minute
DS	Drive state	RTOS	Real-time operating system
EEPROM	Electrical erasable programmable read-only memory	SCL	Scaling
ELCB	Earth leakage circuit breaker	SDP	Status display panel
EMC	Electro-magnetic compatibility	SLVC	Sensorless vector control
EMF	Electromotive force	STW	Control word
EMI	Electro-magnetic interference	STX	Start of text
ESB	Equivalent circuit	SVM	Space vector modulation
FAQ	Frequently asked questions	TTL	Transistor-transistor logic

FB	Function block	USS	Universal serial interface
FCC	Flux current control	VC	Vector control
FCL	Fast current limit	Vdc	DC-link voltage
FF	Fixed frequency	VT	Variable torque
FFB	Free function block	ZSW	Status word
FOC	Field orientated control	ZUSW	Additional setpoint

A.3 MICROMASTER 411 / COMBIMASTER 411 Parts Identification

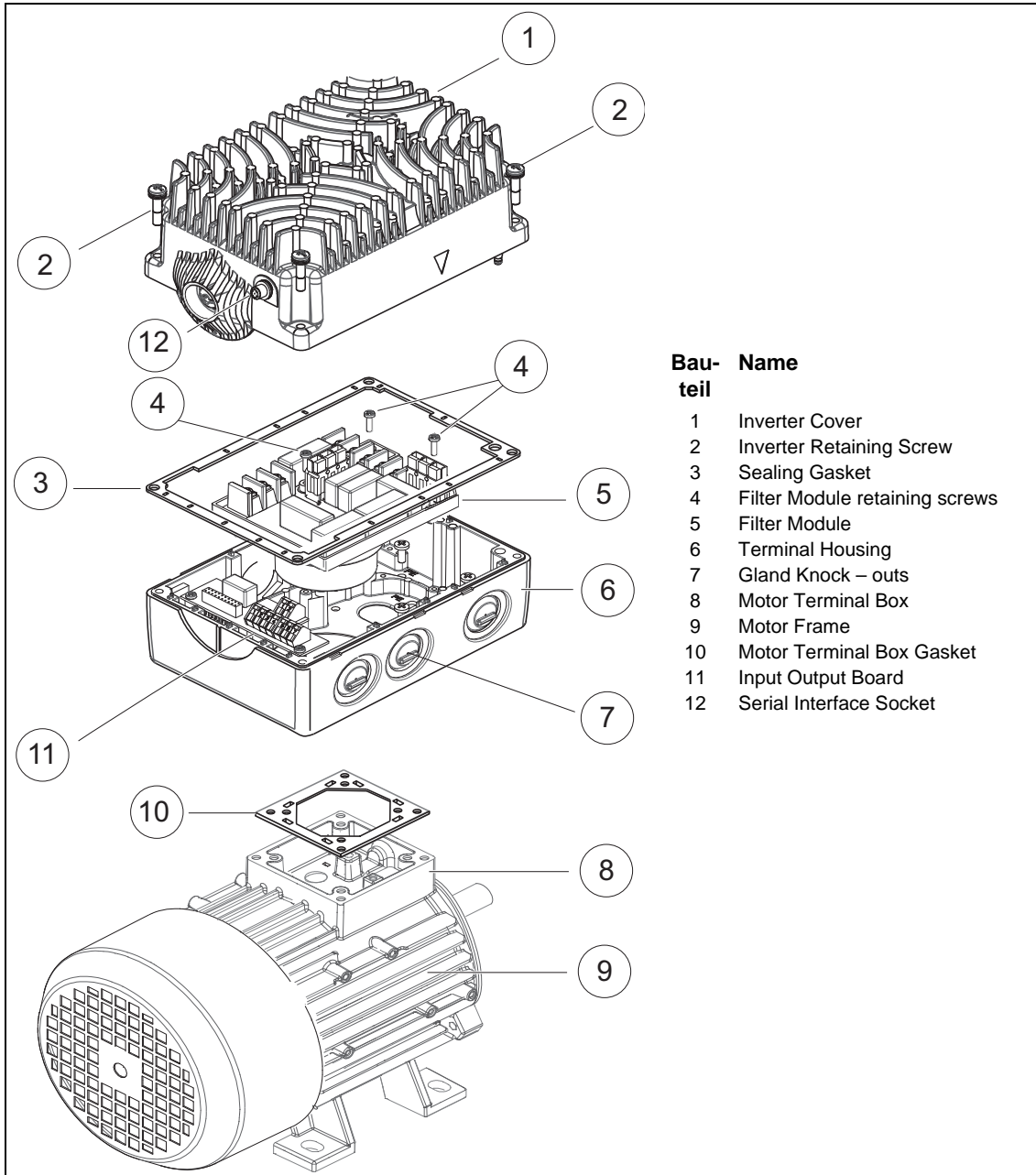

A.4 Index

A

Access Levels · 68
 Advanced Operating Panel (AOP) · 152
 Advanced Operator Panel (AOP) · 53
 Altitude · 22
 Ambient operating conditions · 19, 22
 AOP
 details · 152
 Applicable standards
 European EMC Directive · 155
 European Low Voltage Directive · 155
 European Machinery Directive · 155
 ISO 14001 · 155
 ISO 9001 · 155
 Automatic De-rating · 137

B

Basic Operating Panel (BOP) · 152
 Basic operation
 changing parameters with BOP · 52
 Basic Operation · 57
 Basic Operator Panel
 default settings with BOP · 50
 Basic Operator Panel (BOP) · 50, 101
 BiCo
 cross connections · 141
 BiCo · 115, 138
 operation · 138
 using control words · 140
 using status words · 140
 worked examples · 138
 Binary Connectors · 115, 138
 BiCo · 138
 Block Diagram · 43
 Boost · 120
 BOP/AOP Door Mounting Kit · 153
 Braking · 132
 compound · 134
 dc · 133
 normal · 132
 Vdc max controller · 133

C

Case Size Rating Information · 95
 Chokes · 146
 Closed Loop
 control · 121
 implementation · 121
 setting up · 122
 COMBIMASTER 411 Installation Procedure · 30
 Command Sources · 61, 63
 Commission Overview · 49
 Commissioning · 41
 Commissioning Procedure · 45
 Compound Braking · 64, 134
 Contact address · 5
 Control and Operating Modes · 120
 Control Cable Connections · 37
 Control Circuit Jumpers · 47

Control Modes · 61, 65
 Current Limit · 115, 116
 parameters controlling · 116
 Current Monitoring Accuracy · 117

D

DC braking · 64
 DC Braking · 133
 Default setup · 49
 Derating
 automatic · 137
 for sideways installation · 136
 with altitude · 135
 with switching frequency · 136
 with temperature · 135
 Derating Factors · 135
 Design Features · 17
 Dimensional Detail · 26, 31
 Door Mounting Kit · 107

E

Electrical Installation · 33
 Electro-Magnetic Compatibility
 general · 109, 110
 self-certification · 110
 technical construction file · 110
 Electro-Magnetic Interference · 39
 Electromagnetic radiation · 22
 Electromechanical Brake Control Module · 103
 Elektromagnetische Verträglichkeit
 EMV-Typprüfzertifikat · 110
 EMC · 110
 EMC Compliance Tests · 113
 EMC Directive Compliance · 110
 EMC performance
 filtered for residential, commercial and light industry · 112
 filtered industrial class · 111
 general industrial class · 111

F

Fast Current Limit · 118
 Fault codes
 with the Basic Operator Panel fitted · 80
 Faults and warnings · 65
 AOP fitted · 65
 BOP fitted · 65
 LED Fault Indication · 65
 Flow chart Quick Commissioning · 54
 Flux Current Control · 65
 Foreword · 5
 Frequency Setpoint · 62
 Fuses and Circuit Breakers · 97

G

General operation · 56
 Gland Dimensions · 28

H

Harmonic Currents · 145
 tables · 145
 Humidity Range · 22

- I**
- Installation · 19
- Installation after a Period of Storage · 19, 21
- Installation of Cable Glands · 27
- Installation Procedure · 24
- Internal Overtemperature · 119
- Internet Home Address · 5
- L**
- Line and Motor Connections · 34
- Line Connections · 34
- Linear V/f control · 65
- M**
- Main characteristics · 17
- Mechanical Installation · 19, 23, 30
- MICROMASTER 411
 - General · 16
 - Performance Characteristics · 18
 - Protection characteristics · 18
- MICROMASTER 440
 - main characteristics · 17
- Motor Connections · 34
- Motor Connections for Star/Delta · 35
- Motor data for parameterization · 55
- Motor PTC Connections · 38
- Multi-point V/f control · 65
- N**
- Non - Default Modes of Operation · 58
- O**
- Operation
 - starting and stopping the motor · 63
- Operation with long cables · 33
- Operation with Residual Current Device · 33
- Operator Panel Mounting Kit · 104
- Options · 152
- Overheating · 22
- Overload Operation · 116
- Overview · 15
- Overvoltage · 119
- P**
- Parameter List (short form) · 70
- Parameters
 - changing parameters with BOP · 52
 - system parameters · 67
- Parts Identification · 157
- PC to AOP Connection Kit · 106
- PC to Inverter Connection Kit · 105, 153
- Performance Characteristics · 18
- PI Controller
 - limits · 128
 - responses · 124
- PI Output Limits · 128
- PI setpoint · 123
- Power Losses · 146
 - output graphs · 146
- Preparation · 23
- PROFIBUS · 148
 - characteristics · 148
 - setting up · 151
- PROFIBUS Module · 102
- Programming Options · 100
- Proportional and Integral Control (PI) · 121
- Protection characteristics · 18
- Protection Characteristics
 - fast current limit · 118
 - overtemperature · 119
 - overvoltage and trip · 119
 - thermal · 137
 - using PTC resistors · 118
- Q**
- Quadratic V/f control · 65
- Qualified personnel · 6
- Quick commissioning · 53
- R**
- Ramp Times Using Jumpers · 46
- Reset to Factory default · 55
- S**
- Safety Instructions · 7
- Shock · 22, 115, 147
- Specifications · 93
- Stopping the Motor · 59
- System Parameters · 68
- T**
- Technical Support · 5
- Temperature · 22
- Temperature Coefficient · 118
- Thermal Protection · 115, 137
- Tightening Torque & Cable cross section · 93, 96
- Trip Levels · 119
- Troubleshooting · 79
- Troubleshooting with the Inverter LED · 80
- U**
- Unearthed Supplies · 137
 - operation · 137
- User Options · 99
- V**
- Variant Independent Options · 152
- Vibration · 147
- W**
- Wall Mounting Kit · 29, 108
- Warnings, cautions & notes
 - Commissioning · 9
 - definitions · 6
 - Dismantling & Disposal · 10
 - general · 7
 - Operation · 10
 - Repair · 10
 - Transport & Storage · 8
- Z**
- Ziegler-Nichols · 126

Suggestions and/or Corrections

<p>To: Siemens AG Automation & Drives Group SD SPA PM P.O. Box 3269</p> <p>D-91050 Erlangen Federal Republic of Germany</p> <p>Email: documentation.sd@siemens.com</p>	<p>Suggestions</p> <hr/> <p>Corrections</p> <p>For Publication/Manual: MICROMASTER 411 & COMBIMASTER 411</p>
<p>From Name:</p> <p>Company/Service Department</p> <p>Address: _____</p> <hr/> <p>Telephone: _____ / _____</p> <p>Telefax: _____ / _____</p>	<p>User Documentation</p> <p>Operating Instructions</p> <p>Order Number: 6SE6400-5CA00-0BP0</p> <p>Date of Issue: 07/05</p> <hr/> <p>Should you come across any printing errors when reading this publication, please notify us on this sheet.</p> <p>Suggestions for improvement are also welcome.</p>

Siemens AG
Bereich Automation and Drives (A&D)
Geschäftsgebiet Standard Drives (SD)
Postfach 3269, D-91050 Erlangen
Bundesrepublik Deutschland

© Siemens AG, 2002
Subject to change without prior notice

Order No.: 6SE6400-5CA00-0BP0
Date: 07/05

Siemens Aktiengesellschaft

