

SIEMENS

MICROMASTER 430

7.5 kW - 250 kW

Operating Instructions

Issue 10/06



MICROMASTER 430 Documentation

Getting Started Guide

Is for quick commissioning with SDP and BOP-2.

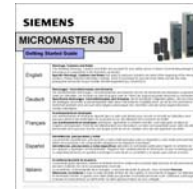

Operating Instructions

Gives information about features of the MICROMASTER 430, Installation, Commissioning, Control modes, System Parameter structure, Troubleshooting, Specifications and available options of the MICROMASTER 430.



Parameter List

The Parameter List contains the description of all Parameters structured in functional order and a detailed description. The Parameter list also includes a series of function plans.



Catalogues

In the catalogue you will find all the necessary information to select an appropriate inverter, as well as filters, chokes, operator panels and communication options.





MICROMASTER 430

7.5 kW - 250 kW

Operating Instructions
User Documentation

Valid for

Issue 10/06

Converter Type
MICROMASTER 430

Software Version
V2.1

Issue 10/06

Overview	1
Installation	2
Commissioning	3
MICROMASTER 430 Functions	4
System Parameters	5
Troubleshooting	6
Specifications	7
Available options	8
Electro-Magnetic Compatibility	9
Appendices	A B C D E F G
Index	

Further information can be obtained from Internet website:

<http://www.siemens.de/micromaster>

Approved Siemens Quality for Software and Training is to DIN ISO 9001, Reg. No. 2160-01

The reproduction, transmission or use of this document, or its contents is not permitted unless authorized in writing. Offenders will be liable for damages. All rights including rights created by patent grant or registration of a utility model or design are reserved.

© Siemens AG 2002, 2005, 2006. All Rights Reserved.

MICROMASTER® is a registered trademark of Siemens

Other functions not described in this document may be available. However, this fact shall not constitute an obligation to supply such functions with a new control, or when servicing.

We have checked that the contents of this document correspond to the hardware and software described. There may be discrepancies nevertheless, and no guarantee can be given that they are completely identical. The information contained in this document is reviewed regularly and any necessary changes will be included in the next edition. We welcome suggestions for improvement.

Siemens handbooks are printed on chlorine-free paper that has been produced from managed sustainable forests. No solvents have been used in the printing or binding process.

Document subject to change without prior notice.

Order number: 6SE6400-5AE00-0BP0

Siemens-Aktiengesellschaft

Foreword

User Documentation



WARNING

Before installing and commissioning the inverter, you must read all safety instructions and warnings carefully including all the warning labels attached to the equipment. Make sure that the warning labels are kept in a legible condition and replace missing or damaged labels.

Information is also available from:

Regional Contacts

Please get in touch with your contact for Technical Support in your Region for questions about services, prices and conditions of Technical Support.

Central Technical Support

The competent consulting service for technical issues with a broad range of requirements-based services around our products and systems.

Europe / Africa

Tel: +49 (0) 180 5050 222

Fax: +49 (0) 180 5050 223

Email: adsupport@siemens.com

America

Tel: +1 423 262 2522

Fax: +1 423 262 2589

Email: simatic.hotline@sea.siemens.com

Asia / Pazific

Tel: +86 1064 757 575

Fax: +86 1064 747 474

Email: adsupport.asia@siemens.com

Online Service & Support

The comprehensive, generally available information system over the Internet, from product support to service & support to the support tools in the shop.

<http://www.siemens.com/automation/service&support>

Contact address

Should any questions or problems arise while reading this manual, please contact the Siemens office concerned using the form provided at the back this manual.

Definitions and Warnings



DANGER

indicates an imminently hazardous situation which, if not avoided, will result in death or serious injury.



WARNING

indicates a potentially hazardous situation which, if not avoided, could result in death or serious injury.



CAUTION

used with the safety alert symbol indicates a potentially hazardous situation which, if not avoided, may result in minor or moderate injury.

CAUTION

used without safety alert symbol indicates a potentially hazardous situation which, if not avoided, may result in a property damage.

NOTICE

indicates a potential situation which, if not avoided, may result in an undesirable result or state.

NOTE

For the purpose of this documentation, "Note" indicates important information relating to the product or highlights part of the documentation for special attention.

Qualified personnel

For the purpose of this Instruction Manual and product labels, a "Qualified person" is someone who is familiar with the installation, mounting, start-up and operation of the equipment and the hazards involved.

He or she must have the following qualifications:

1. Trained and authorized to energize, de-energize, clear, ground and tag circuits and equipment in accordance with established safety procedures.
2. Trained in the proper care and use of protective equipment in accordance with established safety procedures.
3. Trained in rendering first aid.

PE
 = Ground

- PE – Protective Earth uses circuit protective conductors sized for short circuits where the voltage will not rise in excess of 50 Volts. This connection is normally used to ground the inverter.
-  - Is the ground connection where the reference voltage can be the same as the Earth voltage. This connection is normally used to ground the motor.

Use for intended purpose only

The equipment may be used only for the application stated in the manual and only in conjunction with devices and components recommended and authorized by Siemens.

Safety Instructions

The following Warnings, Cautions and Notes are provided for your safety and as a means of preventing damage to the product or components in the machines connected. This section lists Warnings, Cautions and Notes, which apply generally when handling MICROMASTER 430 Inverters, classified as **General, Transport & Storage, Commissioning, Operation, Repair and Dismantling & Disposal**.

Specific Warnings, Cautions and Notes that apply to particular activities are listed at the beginning of the relevant chapters and are repeated or supplemented at critical points throughout these sections.

Please read the information carefully, since it is provided for your personal safety and will also help prolong the service life of your MICROMASTER 430 Inverter and the equipment you connect to it.

General



WARNING

- This equipment contains dangerous voltages and controls potentially dangerous rotating mechanical parts. Non-compliance with **Warnings** or failure to follow the instructions contained in this manual can result in loss of life, severe personal injury or serious damage to property.
- Only suitable qualified personnel should work on this equipment, and only after becoming familiar with all safety notices, installation, operation and maintenance procedures contained in this manual. The successful and safe operation of this equipment is dependent upon its proper handling, installation, operation and maintenance.
- Risk of electric shock. The DC link capacitors remain charged for five minutes after power has been removed. **It is not permissible to open the equipment until 5 minutes after the power has been removed.**
- The following terminals can carry dangerous voltages even if the inverter is inoperative:
 - ◆ the power supply L/L1, N/L2, L3 resp. U1/L1, V1/L2, W1/L3
 - ◆ the motor terminals U, V, W resp. U2, V2, W2
 - ◆ and depending on the frame size the terminals DC+/B+, DC-, B-, DC/R+ resp. DCPS, DCNS, DCPA, DCNA
- HP ratings are based on the Siemens 1LA motors and are given for guidance only; they do not necessarily comply with UL or NEMA HP ratings.



CAUTION

- Children and the general public must be prevented from accessing or approaching the equipment!
- This equipment may only be used for the purpose specified by the manufacturer. Unauthorized modifications and the use of spare parts and accessories that are not sold or recommended by the manufacturer of the equipment can cause fires, electric shocks and injuries.

NOTICE

- Keep these operating instructions within easy reach of the equipment and make them available to all users
- Whenever measuring or testing has to be performed on live equipment, the regulations of Safety Code VBG 4.0 must be observed, in particular §8 “Permissible Deviations when Working on Live Parts”. Suitable electronic tools should be used.
- Before installing and commissioning, please read these safety instructions and warnings carefully and all the warning labels attached to the equipment. Make sure that the warning labels are kept in a legible condition and replace missing or damaged labels.

Transport & Storage**WARNING**

- Correct transport, storage, erection and mounting, as well as careful operation and maintenance are essential for proper and safe operation of the equipment.

CAUTION

- Protect the inverter against physical shocks and vibration during transport and storage. Also be sure to protect it against water (rainfall) and excessive temperatures (see table on page 80).

Commissioning**WARNING**

- Work on the device/system by **unqualified** personnel or failure to comply with warnings can result in severe personal injury or serious damage to material. Only suitably qualified personnel trained in the setup, installation, commissioning and operation of the product should carry out work on the device/system.
- Only permanently-wired input power connections are allowed. This equipment must be grounded (IEC 536 Class 1, NEC and other applicable standards).
- If a Residual Current-operated protective Device (RCD) is to be used, it must be an RCD type B. Machines with a three-phase power supply, fitted with EMC filters, must not be connected to a supply via an ELCB (Earth Leakage Circuit-Breaker - see DIN VDE 0160, section 5.5.2 and EN 50178 section 5.2.11.1).
- The following terminals can carry dangerous voltages even if the inverter is inoperative:
 - the power supply L/L1, N/L2, L3 resp. U1/L1, V1/L2, W1/L3
 - the motor terminals U, V, W resp. U2, V2, W2
 - and depending on the frame size the terminals DC+/B+, DC-, B-, DC/R+ resp. DCPS, DCNS, DCPA, DCNA
- This equipment must not be used as an ‘emergency stop mechanism’ (see EN 60204, 9.2.5.4)

**CAUTION**

The connection of power, motor and control cables to the inverter must be carried out as shown in Figure 2-14 on page 40, to prevent inductive and capacitive interference from affecting the correct functioning of the inverter.

Operation



WARNING

- MICROMASTERS operate at high voltages.
- When operating electrical devices, it is impossible to avoid applying hazardous voltages to certain parts of the equipment.
- Emergency Stop facilities according to EN 60204 IEC 204 (VDE 0113) must remain operative in all operating modes of the control equipment. Any disengagement of the Emergency Stop facility must not lead to uncontrolled or undefined restart.
- Wherever faults occurring in the control equipment can lead to substantial material damage or even grievous bodily injury (i.e. potentially dangerous faults), additional external precautions must be taken or facilities provided to ensure or enforce safe operation, even when a fault occurs (e.g. independent limit switches, mechanical interlocks, etc.).
- Certain parameter settings may cause the inverter to restart automatically after an input power failure.
- Motor parameters must be accurately configured for motor overload protection to operate correctly.
- This equipment is capable of providing internal motor overload protection in accordance with UL508C section 42. Refer to P0610 and P0335, i²t is ON by default. Motor overload protection can also be provided using an external KTY84 or PTC.
- This equipment is suitable for use in a circuit capable of delivering not more than 10,000 (Frame Size C) or 42,000 (Frame Sizes D to GX) symmetrical amperes (rms), for a maximum voltage of 460 V when protected by an H, J or K type fuse, a circuit breaker or self-protected combination motor controller (for more details see Appendix F).
- This equipment must not be used as an 'emergency stop mechanism' (see EN 60204, 9.2.5.4)

Repair



WARNING

- Repairs on equipment may only be carried out by **Siemens Service**, by repair centers **authorized by Siemens** or by **authorized** personnel who are thoroughly acquainted with all the warnings and operating procedures contained in this manual.
- Any defective parts or components must be replaced using parts contained in the relevant spare parts list.
- Disconnect the power supply across all poles before opening the equipment for access.

Dismantling & Disposal

CAUTION

- The inverter's packaging is re-usable. Retain the packaging for future use or return it to the manufacturer.
- Easy-to-release screw and snap connectors allow you to break the unit down into its component parts. You can then re-cycle these component parts, dispose of them in **accordance with local requirements or return them to the manufacturer.**



Electrostatic Sensitive Devices (ESD)

The device contains components which can be destroyed by electrostatic discharge. These components can be easily destroyed if not carefully handled. Before opening the cabinet/enclosure in which the device is located, you must electrically discharge your body and apply the appropriate ESDS protective measures. The cabinet/enclosure should be appropriately labeled.

If you have to handle electronic boards, please observe the following:

- Electronic boards should only be touched when absolutely necessary.
- The human body must be electrically discharged before touching an electronic board.
- Boards must not come into contact with highly insulating materials - e.g. plastic parts, insulated desktops, articles of clothing manufactured from man-made fibers.
- Boards must only be placed on conductive surfaces.
- Boards and components should only be stored and transported in conductive packaging (e.g. metalized plastic boxes or metal containers).
- If the packing material is not conductive, the boards must be wrapped with a conductive packaging material, e.g. conductive foam rubber or household aluminium foil.

The necessary ESD protective measures are clearly shown again in the following diagram:

- a = Conductive floor surface
- b = ESD table
- c = ESD shoes
- d = ESD overall
- e = ESD chain
- f = Cubicle ground connection

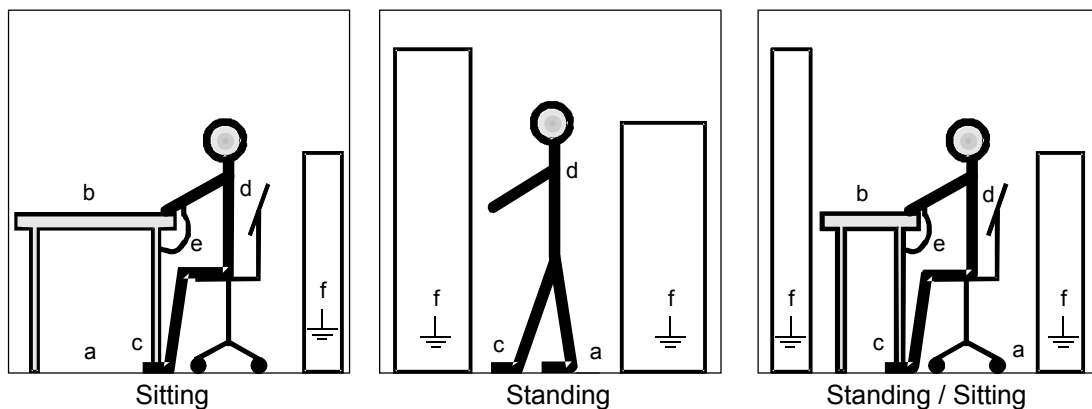

Table of Contents

1	Overview	15
1.1	The MICROMASTER 430.....	16
1.2	Features.....	17
2	Installation	19
2.1	Installation after a Period of Storage	21
2.2	Ambient operating conditions	22
2.3	Mechanical installation.....	24
2.4	Electrical installation	30
3	Commissioning	43
3.1	Block diagram	45
3.2	Commission modes	47
3.3	General operation	58
4	MICROMASTER 430 functions	61
4.1	Frequency set point (P1000)	63
4.2	Command sources (P0700).....	63
4.3	OFF and brake function	64
4.4	Control modes (P1300).....	65
4.5	MICROMASTER 430 operating modes	66
4.6	Free Function Blocks (P2800 ff)	70
4.7	Faults and Alarms	70
5	System parameters.....	71
5.1	Introduction to MICROMASTER system parameters	72
5.2	Parameter overview	73
6	Troubleshooting.....	75
6.1	Troubleshooting with the SDP	76
6.2	Troubleshooting with the BOP-2.....	77
6.3	Fault messages.....	78
6.4	Alarm Messages	78
7	MICROMASTER 430 specifications.....	79
8	Options	87
8.1	Device-independent options	87
8.2	Device-dependent options	87
9	Electro-magnetic compatibility (EMC).....	89
9.1	Electro-magnetic compatibility	90

Appendices	95
A Changing the Operator Panel	95
B Removing Front Covers	96
B.1 Removing Front Covers Frame Size C	96
B.2 Removing Front Covers Frame Sizes D and E	97
B.3 Removing Covers Frame Size F	98
B.4 Removing Front Covers Frame Sizes FX and GX	99
C Removing the I/O Board	100
D Removing 'Y' Cap	101
D.1 Removing 'Y' Cap Frame Size C	101
D.2 Removing 'Y' Cap Frame Sizes D and E	102
D.3 Removing 'Y' Cap Frame Sizes F	103
D.4 Removing 'Y' Cap Frame Sizes FX	104
D.5 Removing 'Y' Cap Frame Sizes GX	105
E Applicable Standards	106
F Short circuit current rating (SCCR)	107
G List of Abbreviations	108
Index	111

List of Illustrations

Figure 2-1	Forming	21
Figure 2-2	Ambient operating temperature	22
Figure 2-3	Installation altitude.....	22
Figure 2-4	Drill pattern for MICROMASTER 430 Frame Sizes C to F	25
Figure 2-5	Installation dimensions for MICROMASTER 430 Frame size FX	26
Figure 2-6	Installation dimensions for MICROMASTER 430 Frame size GX	27
Figure 2-7	Installation of options for the electronic box.....	29
Figure 2-8	MICROMASTER 430 Connection Terminals, Frame Sizes C to F	33
Figure 2-9	MICROMASTER 430 connection drawing – frame size FX.....	34
Figure 2-10	MICROMASTER 430 connection drawing – frame size GX	35
Figure 2-11	Motor and Power Connections	36
Figure 2-12	Adaptation of fan voltage.....	37
Figure 2-13	Control terminals of MICROMASTER 430.....	38
Figure 2-14	Wiring Guidelines to Minimize the Effects of EMI	40
Figure 3-1	Inverter block diagram.....	45
Figure 3-2	Configuration of the analogue input as a digital input.....	46
Figure 3-3	Panels available for the MICROMASTER 430 Inverter	47
Figure 3-4	DIP switch	47
Figure 3-5	Recommended wiring for the factory setting	49
Figure 3-6	Buttons on the BOP-2.....	52
Figure 3-7	Changing parameters via the BOP-2.....	53
Figure 3-8	Typical Motor Rating Plate Example	57
Figure 3-9	Thermal overload protection.....	59
Figure 4-1	Bypass circuit	66
Figure 4-2	Belt Failure Detection	67
Figure 4-3	Motor Staging	68
Figure 4-4	Energy Saving Mode.....	69
Figure 5-1	Parameter Overview.....	73

List of Tables

Table 2-1	Dimensions and Torques of MICROMASTER 430	28
Table 3-1	Default settings for operation using the SDP	48
Table 3-2	Default settings for operation using the BOP-2	51
Table 6-1	Inverter conditions indicated by the LEDs on the SDP	76
Table 7-1	MICROMASTER 430 Performance Ratings	80
Table 7-2	Dimensions, required cooling air flow and tightening torques for power terminals	81
Table 7-3	Current reduction depending on pulse frequency	82
Table 7-4	MICROMASTER 430 Specifications	83
Table 9-1	General Industrial	91
Table 9-2	Filtered Industrial	91
Table 9-3	Filtered for Residential, Commercial and Light Industry	92
Table 9-4	Compliance Table	93

1 Overview

This Chapter contains:

A summary of the major features of the MICROMASTER 430 range.

1.1	The MICROMASTER 430.....	16
1.2	Features.....	17

1.1 The MICROMASTER 430

The MICROMASTER 430s are a range of 3AC-frequency inverters for controlling the speed of three phase AC motors. The various models available range from the 7,5 kW input to the 250 kW input.

The MICROMASTER 430 is especially well suited for use with pumps and ventilators when used with its factory set functions and settings.

The inverters are microprocessor-controlled and use state-of-the-art Insulated Gate Bipolar Transistor (IGBT) technology. This makes them reliable and versatile. A special pulse-width modulation method with selectable Pulse frequency permits quiet motor operation. Comprehensive protective functions provide excellent inverter and motor protection.

1.2 Features

Main Characteristics

- Easy installation
- Easy commissioning
- Rugged EMC design
- Can be operated on IT line supplies
- Fast repeatable response time to control signals
- Comprehensive range of parameters enabling configuration for a wide range of applications
- Simple cable connection
- Output relays
- Analog outputs (0 – 20 mA)
- 6 Isolated and switchable NPN/PNP digital inputs
- 2 Analog inputs:
 - ◆ AIN1: 0 – 10 V, 0 – 20 mA and -10 to +10 V
 - ◆ AIN2: 0 – 10 V, 0 – 20 mA
- The 2 analog inputs can be used as the 7th and 8th digital inputs
- BiCo technology
- Modular design for extremely flexible configuration
- High switching frequencies for low-noise motor operation
- Detailed status information and integrated message functions
- External options for PC communications, Basic Operator Panel (BOP-2) and PROFIBUS communications module
- Pump & Fan Features:
 - ◆ Motor Staging (Control of additional drives via output relay)
 - ◆ Energy Saving Mode
 - ◆ Hand / Auto (manual / automatic) with BOP-2
 - ◆ Belt failure detection (e.g. detects if pumps have run dry)
 - ◆ Bypass

Performance Characteristics

- U/f control
 - ◆ Linear U/f control with flux current control (FCC) for improved dynamic response and motor control
 - ◆ Multiple point U/f control
- Automatic restart
- Flying restart
- Slip compensation
- Fast Current Limitation (FCL) for trip-free operation
- Motor holding brake
- Built-in DC injection brake
- Compound braking to improve braking performance
- Setpoint input via:
 - ◆ Analog inputs
 - ◆ Communication interface
 - ◆ Motorized potentiometer
 - ◆ Fixed frequencies
- Ramp function generator
 - ◆ With smoothing
 - ◆ Without smoothing
- Technology controller (PID)
- parameter set switch-over
 - ◆ Motor data sets (DDS)
 - ◆ Command data sets and setpoint sources (CDS)
- Rating for operation with variable torque (VT)
- Free Function Blocks

Protection characteristics

- Overvoltage/undervoltage protection
- Overtemperature protection for the inverter
- Ground fault protection
- Short-circuit protection
- i^2t thermal motor protection
- PTC/KTY for motor protection

Options

Refer to Chapter 8

2 Installation

This Chapter contains:

- General data relating to installation
- Dimensions of Inverter
- Wiring guidelines to minimize the effects of EMI
- Details concerning electrical installation

2.1	Installation after a Period of Storage	20
2.2	Ambient operating conditions	22
2.3	Mechanical installation.....	24
2.4	Electrical installation	29



WARNING

- Work on the device/system by **unqualified** personnel or failure to comply with warnings can result in severe personal injury or serious damage to material. Only suitably qualified personnel trained in the setup, installation, commissioning and operation of the product should carry out work on the device/system.
 - Only permanently-wired input power connections are allowed. This equipment must be grounded (IEC 536 Class 1, NEC and other applicable standards).
 - If a Residual Current-operated protective Device (RCD) is to be used, it must be an RCD type B. Machines with a three-phase power supply, fitted with EMC filters, must not be connected to a supply via an ELCB (Earth Leakage Circuit-Breaker EN 50178 Section 5.2.11.1).
 - The following terminals can carry dangerous voltages even if the inverter is inoperative:
 - ◆ the power supply L/L1, N/L2, L3 resp. U1/L1, V1/L2, W1/L3
 - ◆ the motor terminals U, V, W resp. U2, V2, W2
 - ◆ and depending on the frame size the terminals DC+/B+, DC-, B-, DC/R+ resp. DCPS, DCNS, DCPA, DCNA
 - Always wait **5 minutes** to allow the unit to discharge after switching off before carrying out any installation work.
 - This equipment must not be used as an 'emergency stop mechanism' (see *EN 60204, 9.2.5.4*).
 - The minimum size of the earth-bonding conductor must be equal to or greater than the cross-section of the power supply cables.
-

CAUTION

The connection of power, motor and control cables to the inverter must be carried out as shown in Figure 2-14 on page 40, to prevent inductive and capacitive interference from affecting the correct functioning of the inverter.

2.1 Installation after a Period of Storage

Following a prolonged period of storage, you must reform the capacitors in the inverter. The requirements are listed below.

Frame Sizes C to F

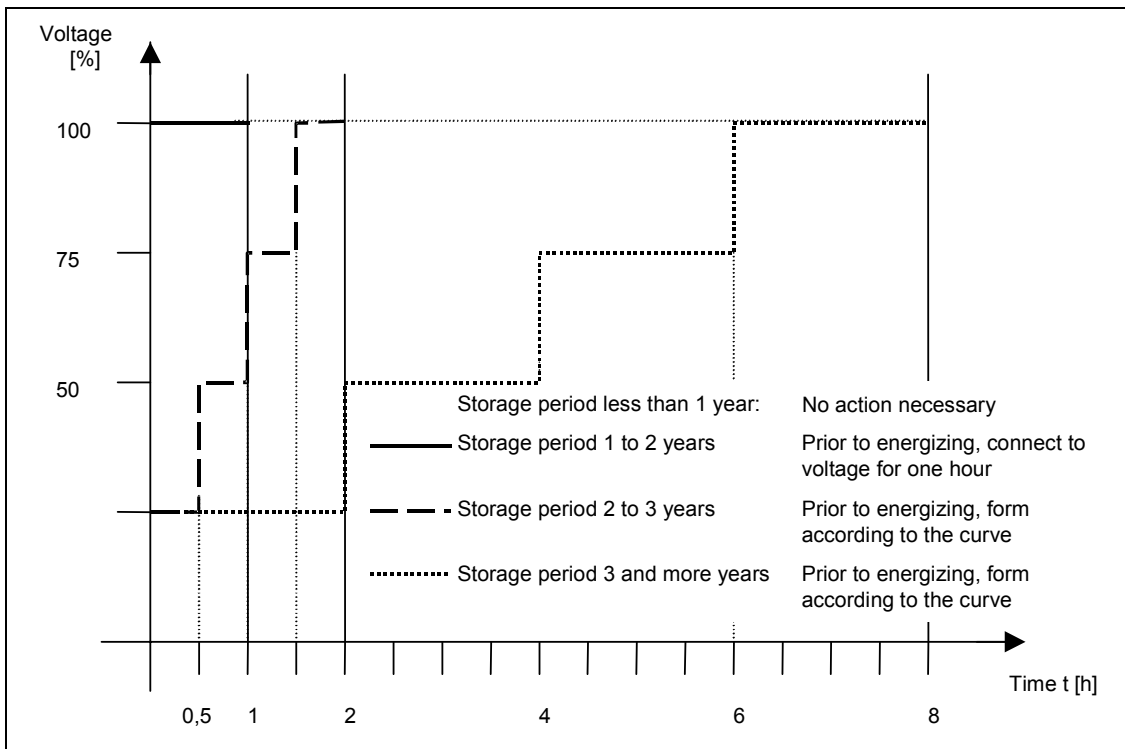

Figure 2-1 Forming

Frame Sizes FX and GX

Reforming the capacitors can be accomplished by applying 85% of the rated input voltage for at least 30 minutes without load.

2.2 Ambient operating conditions

Temperature

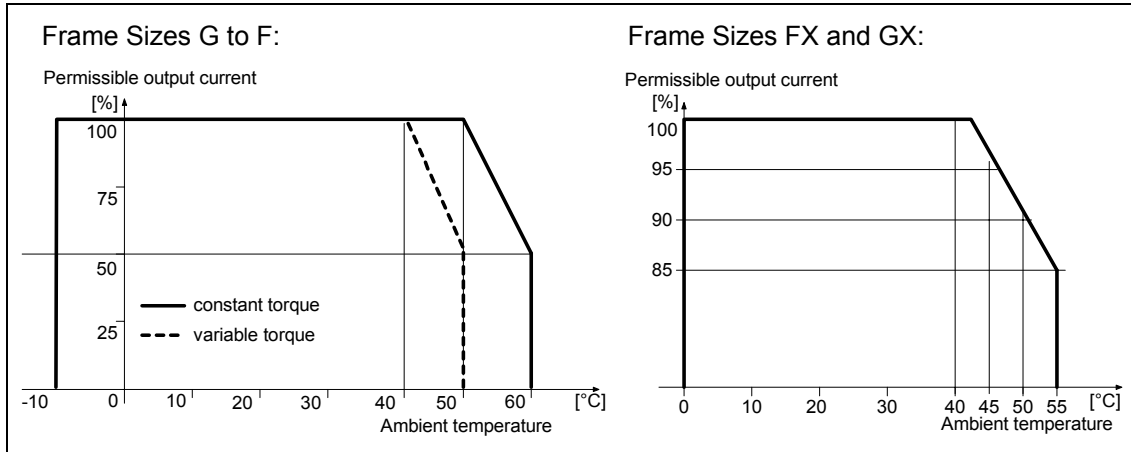

Figure 2-2 Ambient operating temperature

Humidity Range

Relative air humidity $\leq 95\%$ Non-condensing

Altitude

If the inverter is to be installed at an altitude $> 1000\text{ m}$ or $> 2000\text{ m}$ above sea level, derating will be required:

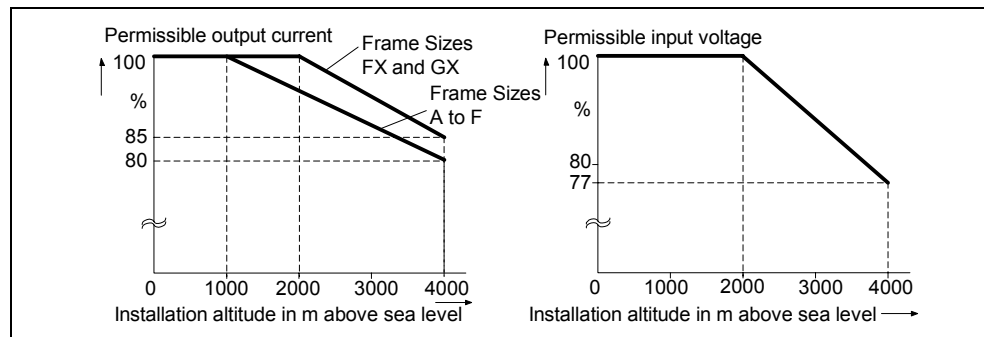

Figure 2-3 Installation altitude

Shock and Vibration

Do not drop the inverter or expose to sudden shock. Do not install the inverter in an area where it is likely to be exposed to constant vibration.

Mechanical strength to EN 60721-3-3

- Deflection: 0.075 mm (10 ... 58 Hz)
- Acceleration: 9.8 m/s² ($> 58 \dots 200$ Hz)

Electromagnetic Radiation

Do not install the inverter near sources of electromagnetic radiation.

Atmospheric Pollution

Do not install the inverter in an environment, which contains atmospheric pollutants such as dust, corrosive gases, etc.

Water

Take care to site the inverter away from potential water hazards, e.g. do not install the inverter beneath pipes that are subject to condensation. Avoid installing the inverter where excessive humidity and condensation may occur.

Installation and cooling**CAUTION**

The inverters **MUST NOT** be mounted horizontally.

The inverters can be mounted without any clearance at either side.

When mounting inverters one above the other, the specified environmental conditions must not be exceeded.

Independent of this, these minimum distances must be observed.

- Frame Size C above and below 100 mm
- Frame Size D, E above and below 300 mm
- Frame Size F above and below 350 mm
- Frame Size FX, GX above 250 mm
 below 150 mm
 in front 40 mm (FX), 50 mm (GX)

No equipment that could have a negative effect on the flow of cooling air should be installed in this area. Make sure that the cooling vents in the inverter are positioned correctly to allow free movement of air.

2.3 Mechanical installation



WARNING

- To ensure the safe operation of the equipment, it must be installed and commissioned by qualified personnel in full compliance with the warnings laid down in these operating instructions.
- Take particular note of the general and regional installation and safety regulations regarding work on dangerous voltage installations (e.g. EN 50178), as well as the relevant regulations regarding the correct use of tools and personal protective equipment (PPE).
- The mains input, DC and motor terminals, can carry dangerous voltages even if the inverter is inoperative; wait 5 minutes to allow the unit to discharge after switching off before carrying out any installation work.
- The inverters can be mounted without any clearance at either side. When mounting inverters one above the other, the specified environmental conditions must not be exceeded. Independent of this, these minimum distances must be observed.

◆ Frame Size C	above and below 100 mm
◆ Frame Size D, E	above and below 300 mm
◆ Frame Size F	above and below 350 mm
◆ Frame Size FX, GX	above 250 mm below 150 mm in front 40 mm (FX), 50 mm (GX)
- If the front cover (Frame Sizes FX and GX) has been removed, the fan impeller is exposed. There is danger of injury when the fan is running.
- IP20 protection is only against direct contact, always use these products within a protective cabinet.

Removing from transport pallet (only for framesizes FX and GX)

During transport, the inverter is fastened on the transport pallet with the aid of two iron brackets.



WARNING

Note that the center of gravity of the inverter is not in the middle of the unit. When lifting the pallet, the unit can therefore suddenly change position and swing to the side.

1. Fasten the hoisting crane cable to the hoisting eyes on the inverter (2 eyes (see Figure 2-9 for frame size FX Figure 2-10 for frame size GX)).
2. Remove the two retaining bolts at the top of the front cover.
3. Unscrew the bolts in the iron brackets on the transport pallet and lift the inverter off the pallet.
4. Once installation has been completed and the inverter connected, fasten the two retaining bolts for the front cover at the bottom side of the door.

Frame Sizes C to F

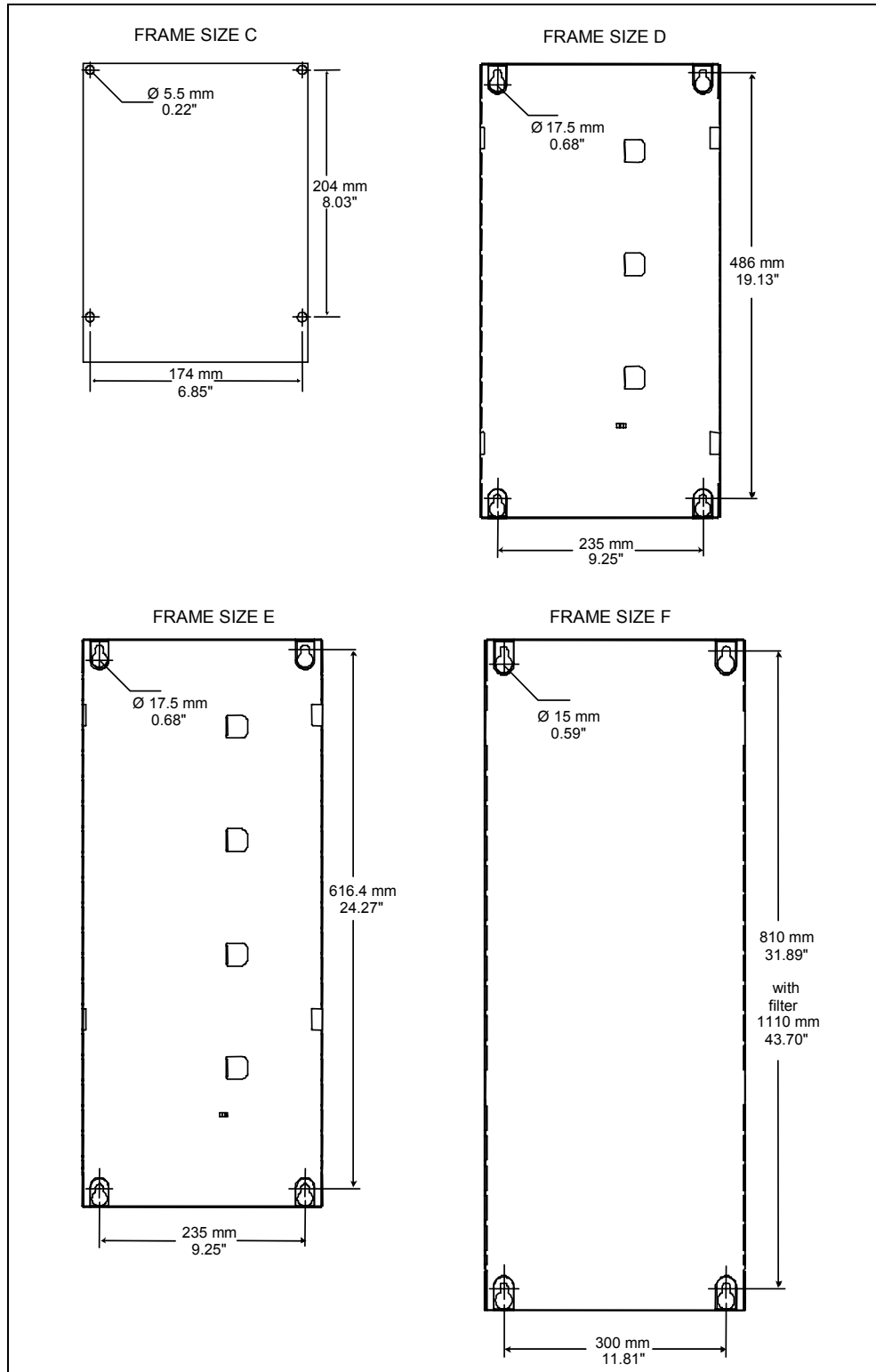

Figure 2-4 Drill pattern for MICROMASTER 430 Frame Sizes C to F

Frame Size FX

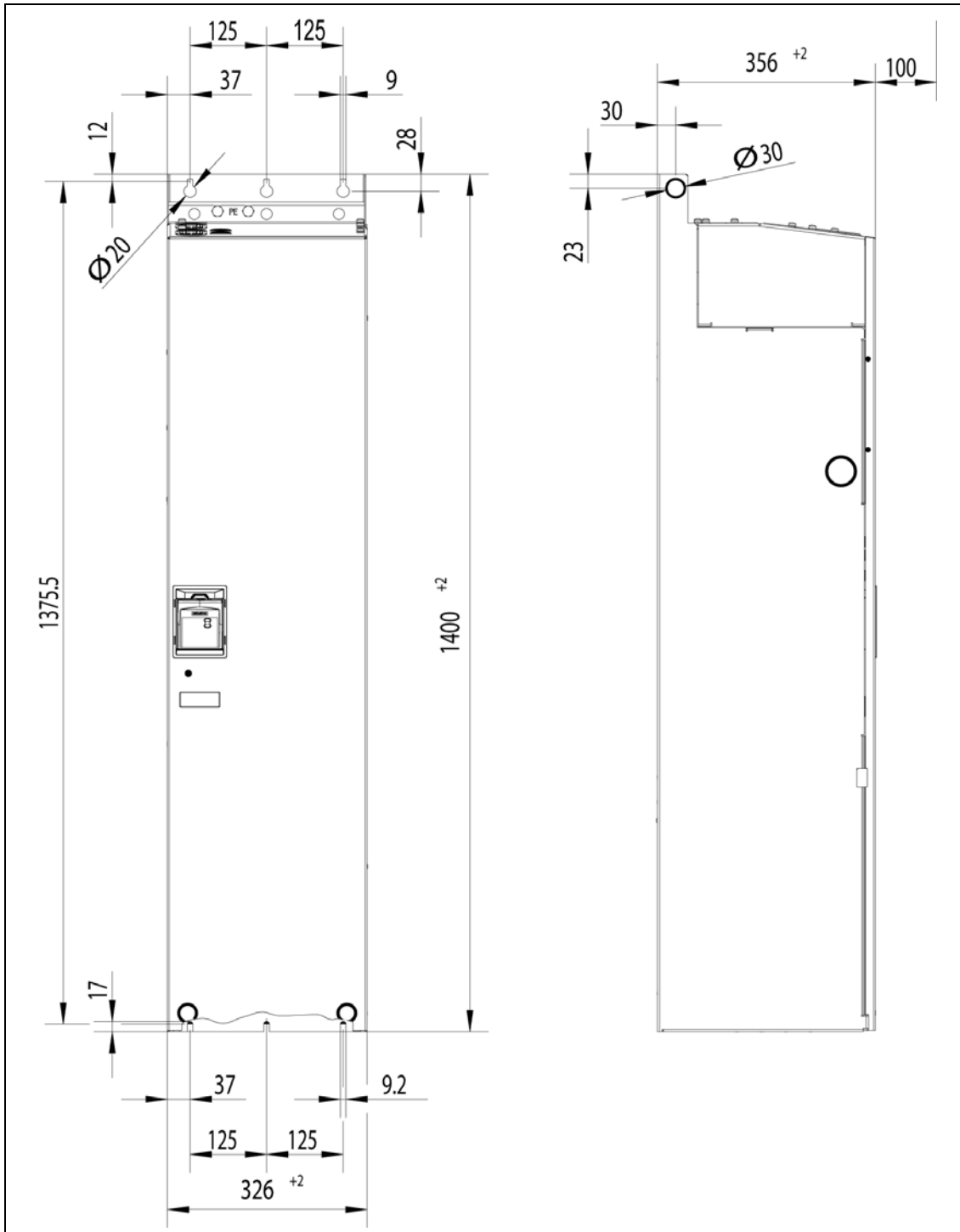

Figure 2-5 Installation dimensions for MICROMASTER 430 Frame size FX

Frame Size GX

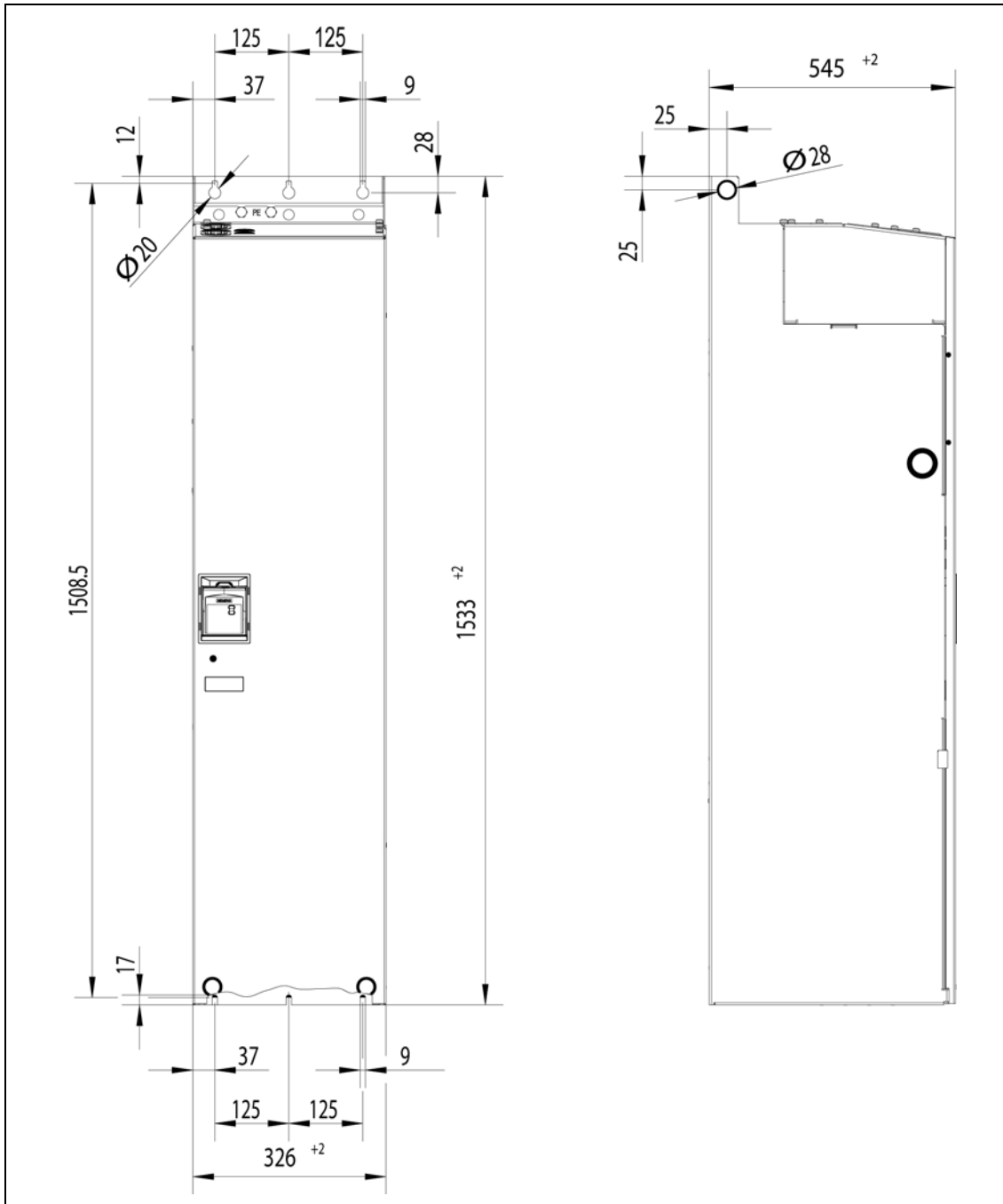

Figure 2-6 Installation dimensions for MICROMASTER 430 Frame size GX

Table 2-1 Dimensions and Torques of MICROMASTER 430

Frame-Size		Overall Dimensions		Fixing Method	Tightening Torque
C	Width x Height x Depth	mm	185 x 245 x 195	4 x M5 Bolts 4 x M5 Nuts 4 x M5 Washers	2.5 Nm with washers fitted
		inch	7.28 x 9.65 x 7.68		
D	Width x Height x Depth	mm	275 x 520 x 245	4 x M8 Bolts 4 x M8 Nuts 4 x M8 Washers	3.0 Nm with washers fitted
		inch	10.82 x 20.47 x 9.65		
E	Width x Height x Depth	mm	275 x 650 x 245	4 x M8 Bolts 4 x M8 Nuts 4 x M8 Washers	3.0 Nm with washers fitted
		inch	10.82 x 25.59 x 9.65		
F	Width x Height x Depth	mm	350 x 850 mm x 320 height with filter 1150	4 x M8 Bolts 4 x M8 Nuts 4 x M8 Washers	3.0 Nm with washers fitted
		inch	13.78 x 33.46 x 12.60 height with filter 45.28		
FX	Width x Height x Depth	mm	326 x 1400 x 356	6 M 8 Bolts 6 M 8 Nuts 6 M 8 Washers	13 Nm +30 % with washers fitted
		inch	12,80 x 55,12 x 12,83		
GX	Width x Height x Depth	mm	326 x 1533 x 545	6 M 8 Bolts 6 M 8 Nuts 6 M 8 Washers	13 Nm +30 % with washers fitted
		inch	12,80 x 60,35 x 21,46		

2.3.1 Installing communication options and/or pulse encoder evaluation module

Frame Size C

NOTE

When installing the following options – PROFIBUS module, DeviceNet module, CANopen option module and/or pulses encoder evaluation module, the mounting depth of the drive inverter is increased!

Please refer to the relevant Operating Instructions for the actual procedure.

Frame Sizes FX and GX

The front cover of the MICROMASTER 440 is designed so that the control module (normally the SDP) is almost flush with the opening in the front cover. If more than one option is to be installed in the electronic box, it is necessary to position the entire electronic box further to the rear.

Installing the options

- Remove the front cover:
 - Unscrew two screws at the bottom side of the front cover.
 - Lift front cover up and out.
- Remove retaining screws on the electronic box.
- Screw on electronic box in correct installation position as shown in Figure 2-7
- Install additional options.
- Reinstall front cover.

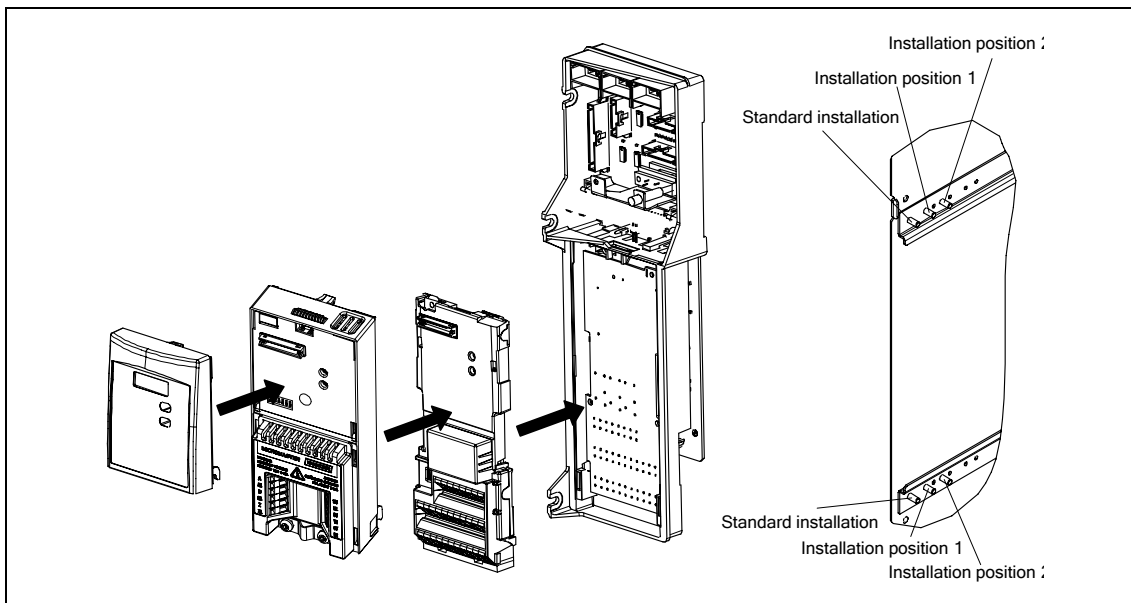

Figure 2-7 Installation of options for the electronic box

2.4 Electrical installation



WARNING

- **The inverter must always be grounded.**
 - To ensure the safe operation of the equipment, it must be installed and commissioned by qualified personnel in full compliance with the warnings laid down in these operating instructions.
 - Take particular note of the general and regional installation and safety regulations regarding work on dangerous voltage installations (e.g. EN 50178), as well as the relevant regulations regarding the correct use of tools and personal protective gear.
 - Never use high voltage insulation test equipment on cables connected to the inverter.
 - The mains input, DC and motor terminals, can carry dangerous voltages even if the inverter is inoperative; wait **5 minutes** to allow the unit to discharge after switching off before carrying out any installation work.
 - If the front cover (Frame Sizes FX and GX) has been removed, the fan impeller is exposed. There is danger of injury when the fan is running.
-

CAUTION

The control, power supply and motor leads **must** be laid separately. Do not feed them through the same cable conduit/trunking.

2.4.1 General



WARNING

The inverter must always be grounded. If the inverter is not grounded correctly, extremely dangerous conditions may arise within the inverter which could prove potentially fatal.

Operation with ungrounded (IT) supplies

Filtered

The use of MICROMASTER 4 inverters with built in filters is not allowed on IT supplies.

Unfiltered

In the case of non-grounded networks, the 'Y' capacitor of the device must be made ineffective. The procedure is described in Appendix D.

If the MICROMASTER is to remain in operation in non-grounded networks when a ground fault occurs during the input or output phase, an output reactor must be installed.

Operation with Residual Current Device (Frame Sizes C to F)

If an RCD (also referred to as ELCB or RCCB) is fitted, the MICROMASTER inverters will operate without nuisance tripping, provided that:

- A type B RCD is used.
- The trip limit of the RCD is 300 mA.
- The neutral of the supply is grounded.
- Only one inverter is supplied from each RCD.
- The output cables are less than 50 m (screened) or 100 m (unscreened).

NOTE

The residual current operated circuit-breakers used must provide protection against direct-current components in the fault current and must be suitable for briefly suppressing power pulse current peaks. It is recommended to protect the frequency inverter by fuse separately.

The regulations of the individual country (e.g. VDE regulations in Germany) and the regional power suppliers must be observed!

2.4.2 Power and motor connections



WARNING

The inverter must always be grounded.

- Isolate the mains electrical supply before making or changing connections to the unit.
- When synchronous motors are connected or when coupling several motors in parallel, the inverter must be operated with voltage/frequency control characteristic (P1300 = 0, 2 or 3).



CAUTION

After connecting the power and motor cables to the proper terminals, make sure that the front covers have been replaced properly before supplying power to the unit!

NOTICE

- Ensure that the appropriate circuit-breakers/fuses with the specified current rating are connected between the power supply and inverter (see chapter 7, Tables starting on page 82).
- Use Class 1 60/75°C copper wire only (for UL compliance). For tightening torque see Table 7-2 on page 81.

Operation with long cables

All inverters will operate at full specification with cable lengths as follows:

Frame Sizes	C to F	FX and GX
screened	50 m	100 m
unscreened	100 m	150 m

Using the output chokes specified in catalogue DA 51.2, the following cable lengths are possible for all frame sizes:

Supply Voltage	380 V ... 400 V ± 10 %			401 V ... 480 V ± 10 %		
Frame Sizes	C	D to F	FX, GX	C	D to F	FX, GX
screened	200 m	200 m	300 m	100 m	200 m	300 m
unscreened	300 m	300 m	450 m	150 m	300 m	450 m

CAUTION

If using output chokes operation is only permissible with a pulse frequency of **4 kHz**. Make shure that the automatic pulse frequency reductions are disabled.
Coercing required parameter adjusting: P1800 = 4 kHz , P0290 = 0 or 1.

Access to the power and motor terminals

Access to the power supply and motor terminals is possible by removing the front covers (See Figure 2-8 to Figure 2-10). See also Appendix B.

After removing the front covers and exposing the terminals, complete power and motor connections as shown Figure 2-11.

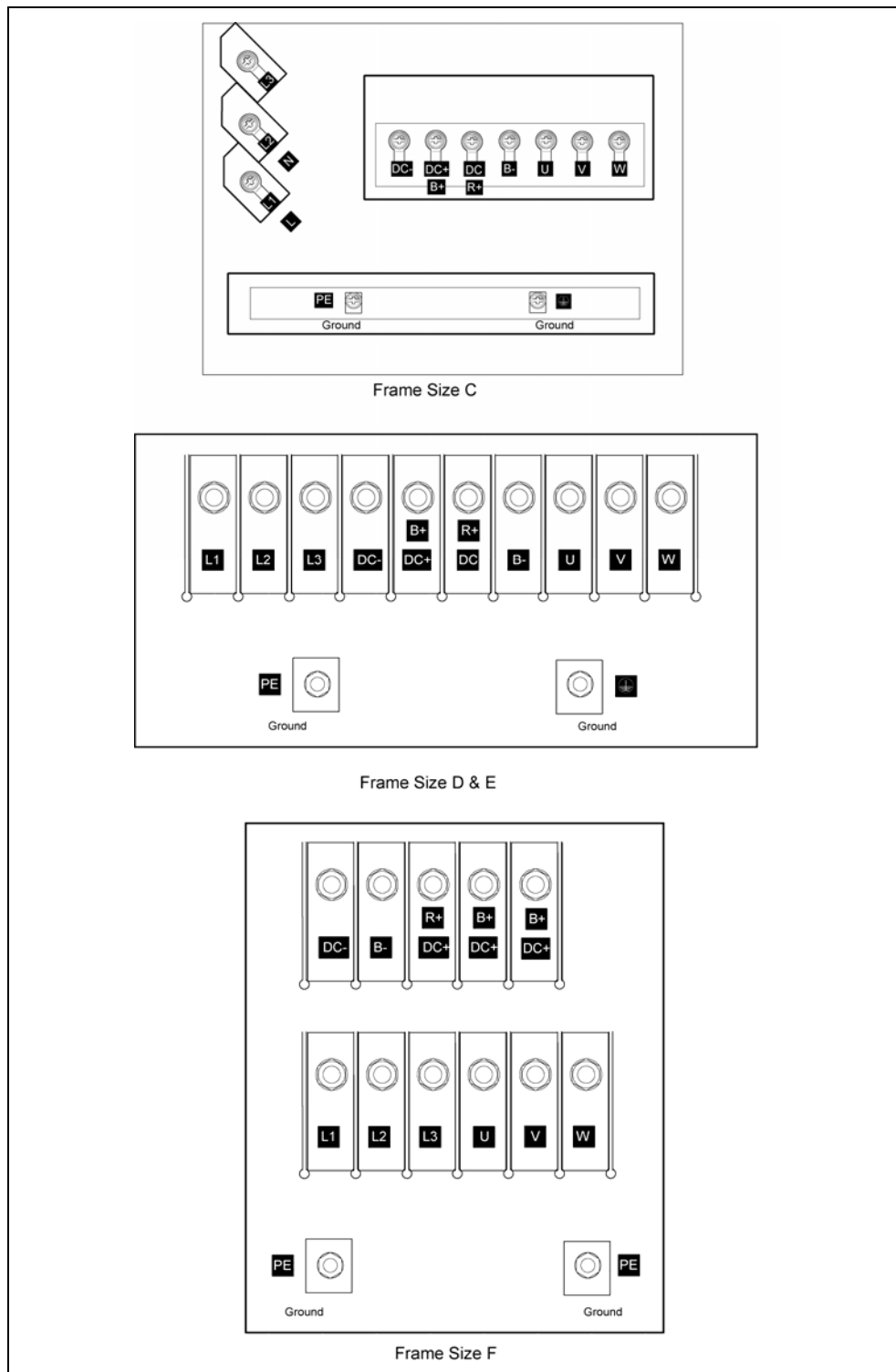

Figure 2-8 MICROMASTER 430 Connection Terminals, Frame Sizes C to F

NOTE

The DC connections are for testing purposes only and have not been released for operation by the user. No brake resistors etc. may be connected here.

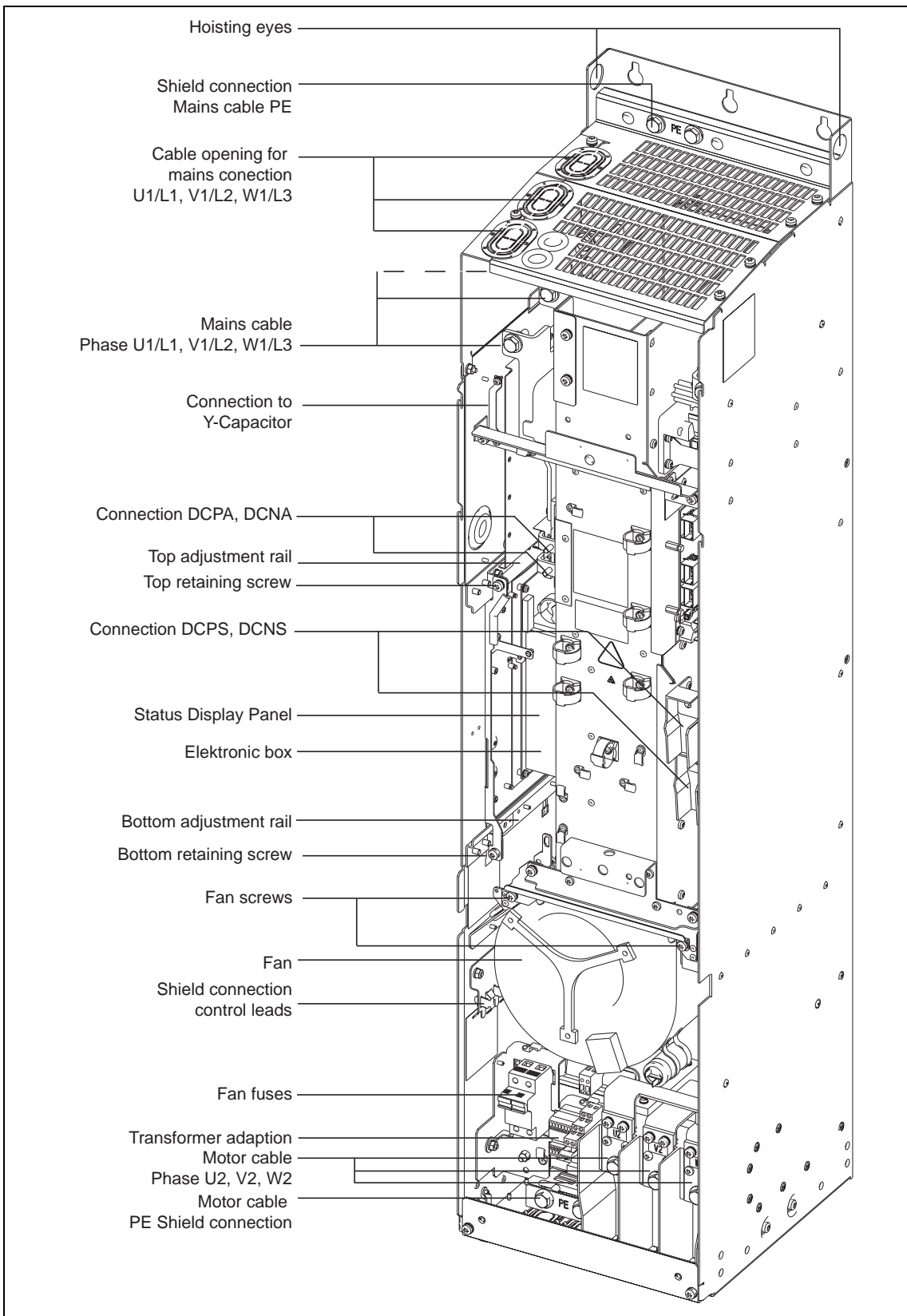

Figure 2-9 MICROMASTER 430 connection drawing – frame size FX

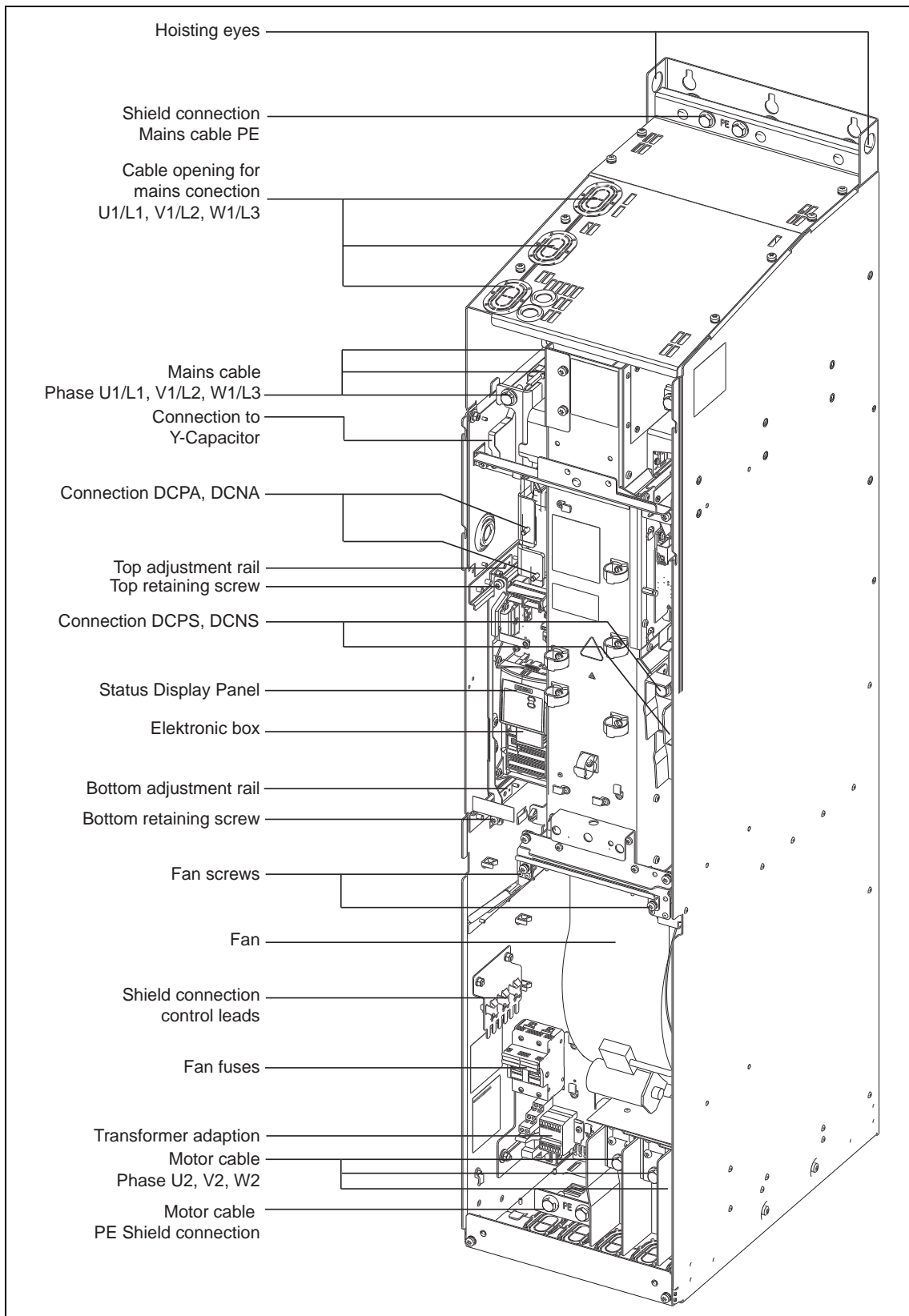
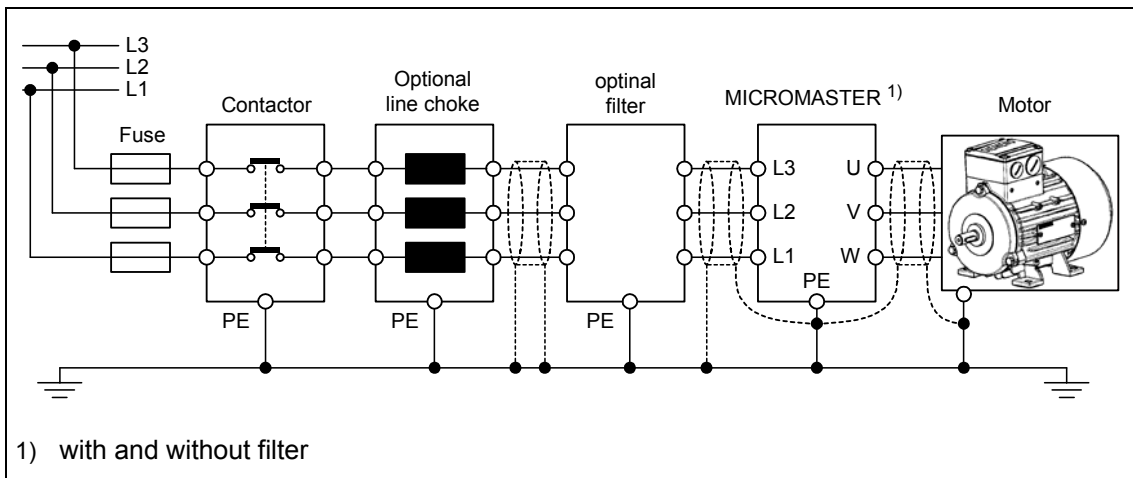

Figure 2-10 MICROMASTER 430 connection drawing – frame size GX

Frame Sizes C to F



Frame Sizes FX and GX

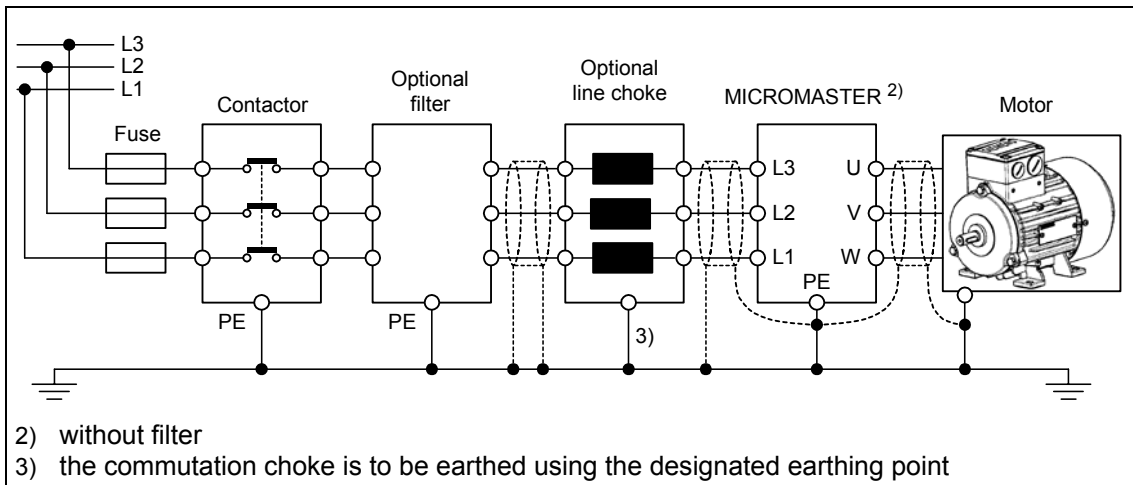

Figure 2-11 Motor and Power Connections

Adaptation of fan voltage (only for framesize FX and GX)

A transformer is installed to adapt the existing line voltage to the fan voltage. It may be necessary to reconnect the transformer terminals on the primary side to coincide with the existing line power.

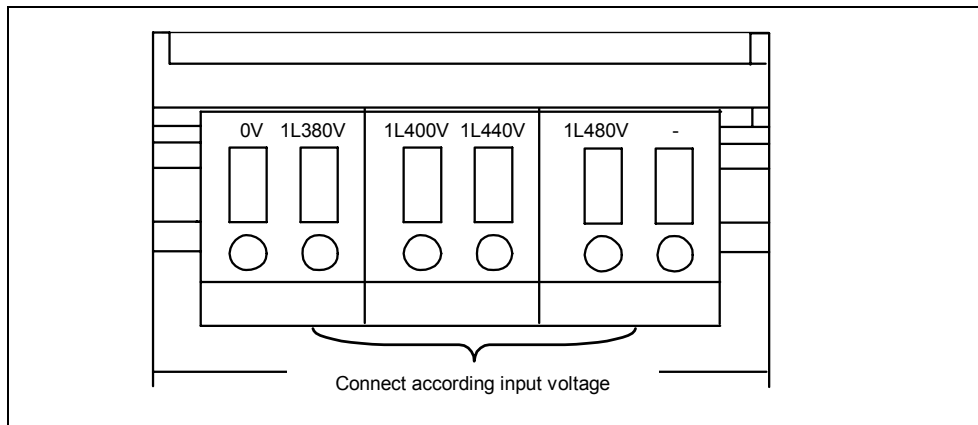

Figure 2-12 Adaptation of fan voltage

CAUTION

If the terminals are not reconnected to the actually present line voltage, the fan fuses can blow.

Replacement for fan fuses

Frame size	Fuses (2 each)	Recommended fuses
FX (90 kW CT)	1 A / 600 V / slow-acting	Cooper-Bussmann FNQ-R-1, 600 V or comparable fuse
FX (110 kW CT)	2,5 A / 600 V / slow-acting	Ferraz Gould Shawmut ATDR2-1/2, 600 V or comparable fuse
GX (132-200 kW CT)	4 A / 600 V / slow-acting	Ferraz Gould Shawmut ATDR4, 600 V or comparable fuse

2.4.3 Control terminals

Permitted cable diameters: 0.08 ... 2.5 mm² (AWG: 28 ... 12)

Terminal	Designation	Function
1	–	Output +10 V
2	–	Output 0 V
3	ADC1+	Analog input 1 (+)
4	ADC1-	Analog input 1 (-)
5	DIN1	Digital input 1
6	DIN2	Digital input 2
7	DIN3	Digital input 3
8	DIN4	Digital input 4
9	–	Isolated output +24 V / max. 100 mA
10	ADC2+	Analog input 2 (+)
11	ADC2-	Analog input 2 (-)
12	DAC1+	Analog output 1 (+)
13	DAC1-	Analog output 1 (-)
14	PTCA	Connection for PTC / KTY84
15	PTCB	Connection for PTC / KTY84
16	DIN5	Digital input 5
17	DIN6	Digital input 6
18	DOUT1/NC	Digital output 1 / NC contact
19	DOUT1/NO	Digital output 1 / NO contact
20	DOUT1/COM	Digital output 1 / Changeover contact
21	DOUT2/NO	Digital output 2 / NO contact
22	DOUT2/COM	Digital output 2 / Changeover contact
23	DOUT3/NC	Digital output 3 / NC contact
24	DOUT3/NO	Digital output 3 / NO contact
25	DOUT3/COM	Digital output 3 / Changeover contact
26	DAC2+	Analog output 2 (+)
27	DAC2-	Analog output 2 (-)
28	–	Isolated output 0 V / max. 100 mA
29	P+	RS485 port
30	N-	RS485 port

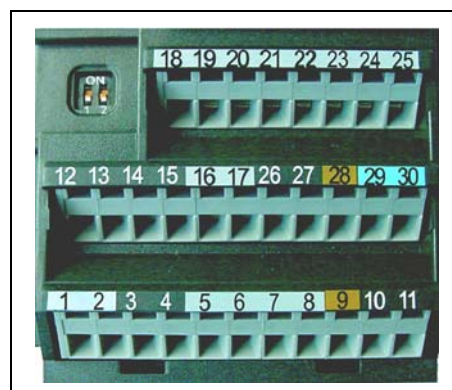

Figure 2-13 Control terminals of MICROMASTER 430

2.4.4 Avoiding Electro-Magnetic Interference (EMI)

The inverters are designed to operate in an industrial environment where a high level of EMI can be expected. Usually, good installation practices will ensure safe and trouble-free operation. If you encounter problems, follow the guidelines stated below.

Action to Take

- Ensure that all equipment in the cubicle is well grounded using short, thick grounding cable connected to a common star point or busbar.
- Make sure that any control equipment (such as a PLC) connected to the inverter is connected to the same ground or star point as the inverter via a short thick link.
- Connect the return ground from the motors controlled by the inverters directly to the ground connection (PE) on the associated inverter.
- Flat conductors are preferred as they have lower impedance at higher frequencies.
- Terminate the ends of the cable neatly, ensuring that unscreened wires are as short as possible.
- **Separate the control cables from the power cables as much as possible, using separate trunking, if necessary at 90° to each other.**
- Whenever possible, use screened leads for the connections to the control circuitry.
- Ensure that the contactors in the cubicle are suppressed, either with R-C suppressors for AC contactors or 'flywheel' diodes for DC contactors fitted to the coils. Varistor suppressors are also effective. This is important when the contactors are controlled from the inverter relay.
- Use screened or armored cables for the motor connections and ground the screen at both ends using the cable clamps.



WARNING

Safety regulations **must not** be compromised when installing inverters!

2.4.5 Screening Methods

Frame Size C

For frame size C the Gland Plate Kit is supplied as an option. It allows easy and efficient connection of the necessary screening. See the Gland Plate Installation Instructions contained on the Document CD-ROM, supplied with the MM430.

Screening without a Gland Plate

Should a Gland Plate not be available, then the inverter can be screened using the methodology shown in Figure 2-14.

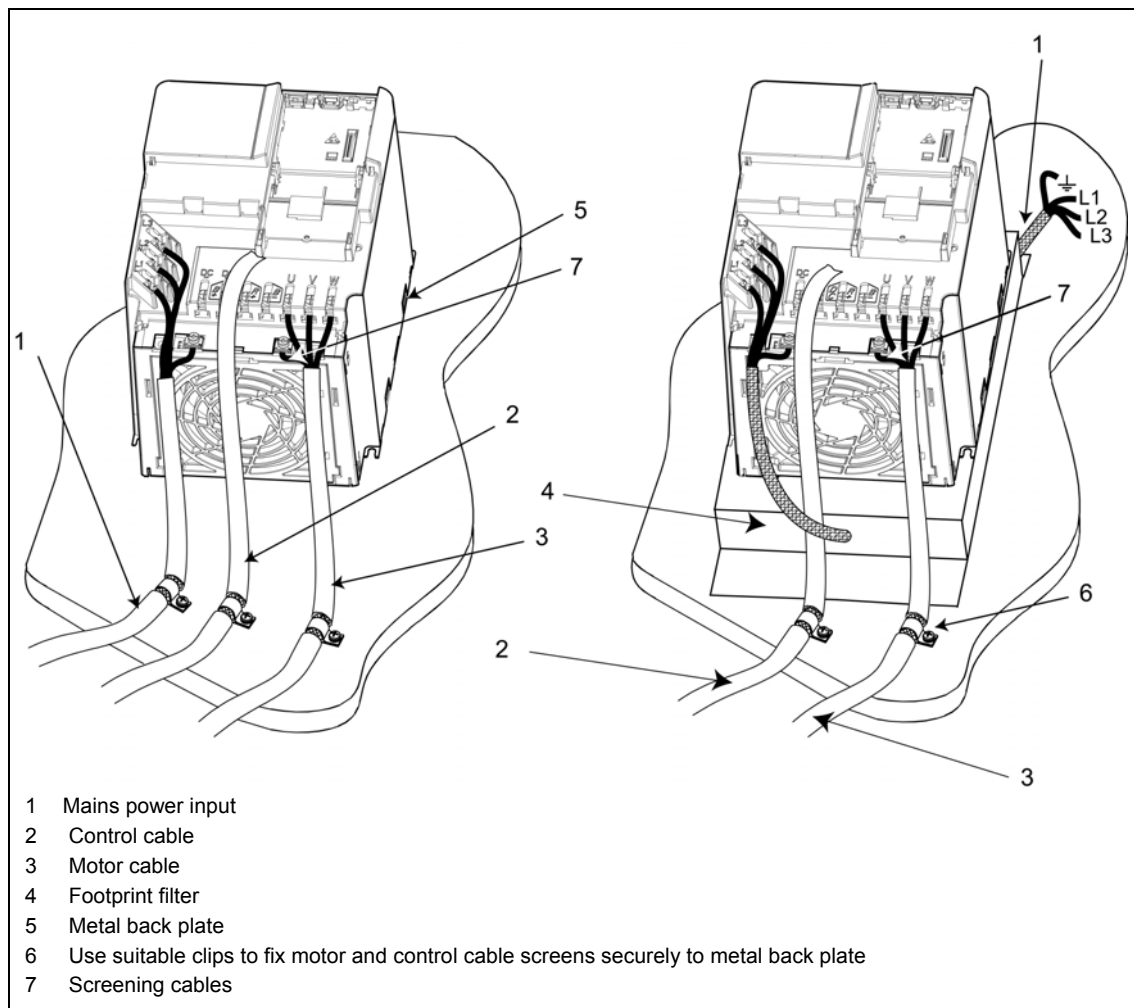

Figure 2-14 Wiring Guidelines to Minimize the Effects of EMI

Frame Sizes D and E

The Gland Plate is factory fitted. If the installation conditions are restricted, the shield of the motor cable can also be attached outside the cabinet, as shown in Figure 2-14, for example.

Frame size F

The gland plate for the control cables is factory-fitted.

Devices without filter: The shield of the motor cable must be attached outside the cabinet, as shown in Figure 2-14, for example.

Devices with filter: The gland plate for the motor cable is factory-fitted.

Frame Sizes FX and GX

Attach the shields for the control cable as shown in the connection overview (see Figure 2-9 and Figure 2-10) to the marked shield connection over a large surface.

Twist the shields of the motor cables and screw them to the PE connection for the motor cable.

When using an EMI filter, a power commutating choke is required. The wire shields should be fastened to the metallic mounting surface as close as possible to the components.

3 Commissioning

This Chapter contains:

- A schematic diagram of the MICROMASTER 430
- An overview of the commissioning options and the display and operator panels
- An overview of quick commissioning of the MICROMASTER 430

3.1	Block diagram	45
3.2	Commission modes	46
3.3	General operation	56



WARNING

- MICROMASTERS operate at high voltages.
 - When operating electrical devices, it is impossible to avoid applying hazardous voltages to certain parts of the equipment.
 - The following terminals can carry dangerous voltages even if the inverter is inoperative:
 - ◆ the power supply L/L1, N/L2, L3 resp. U1/L1, V1/L2, W1/L3
 - ◆ the motor terminals U, V, W resp. U2, V2, W2
 - ◆ and depending on the frame size the terminals DC+/B+, DC-, B-, DC/R+ resp. DCPS, DCNS, DCPA, DCNA
 - Emergency Stop facilities according to EN 60204 IEC 204 (VDE 0113) must remain operative in all operating modes of the control equipment. Any disengagement of the Emergency Stop facility must not lead to uncontrolled or undefined restart.
 - Wherever faults occurring in the control equipment can lead to substantial material damage or even grievous bodily injury (i.e. potentially dangerous faults), additional external precautions must be taken or facilities provided to ensure or enforce safe operation, even when a fault occurs (e.g. independent limit switches, mechanical interlocks, etc.).
 - Certain parameter settings may cause the inverter to restart automatically after an input power failure.
 - Motor parameters must be accurately configured for motor overload protection to operate correctly.
 - This equipment is capable of providing internal motor overload protection in accordance with UL508C section 42. Refer to P0610 and P0335, i²t is ON by default. Motor overload protection can also be provided using an external KTY84 or PTC.
 - This equipment is suitable for use in a circuit capable of delivering not more than 10,000 (Frame Size C) or 42,000 (Frame Sizes D to GX) symmetrical amperes (rms), for a maximum voltage of 460 V when protected by an H, J or K type fuse, a circuit breaker or self-protected combination motor controller (for more details see Appendix F).
This equipment must not be used as an 'emergency stop mechanism' (see EN 60204, 9.2.5.4).
-



CAUTION

Only qualified personnel may enter settings in the control panels. Particular attention must be paid to safety precautions and warnings at all times.

3.1 Block diagram

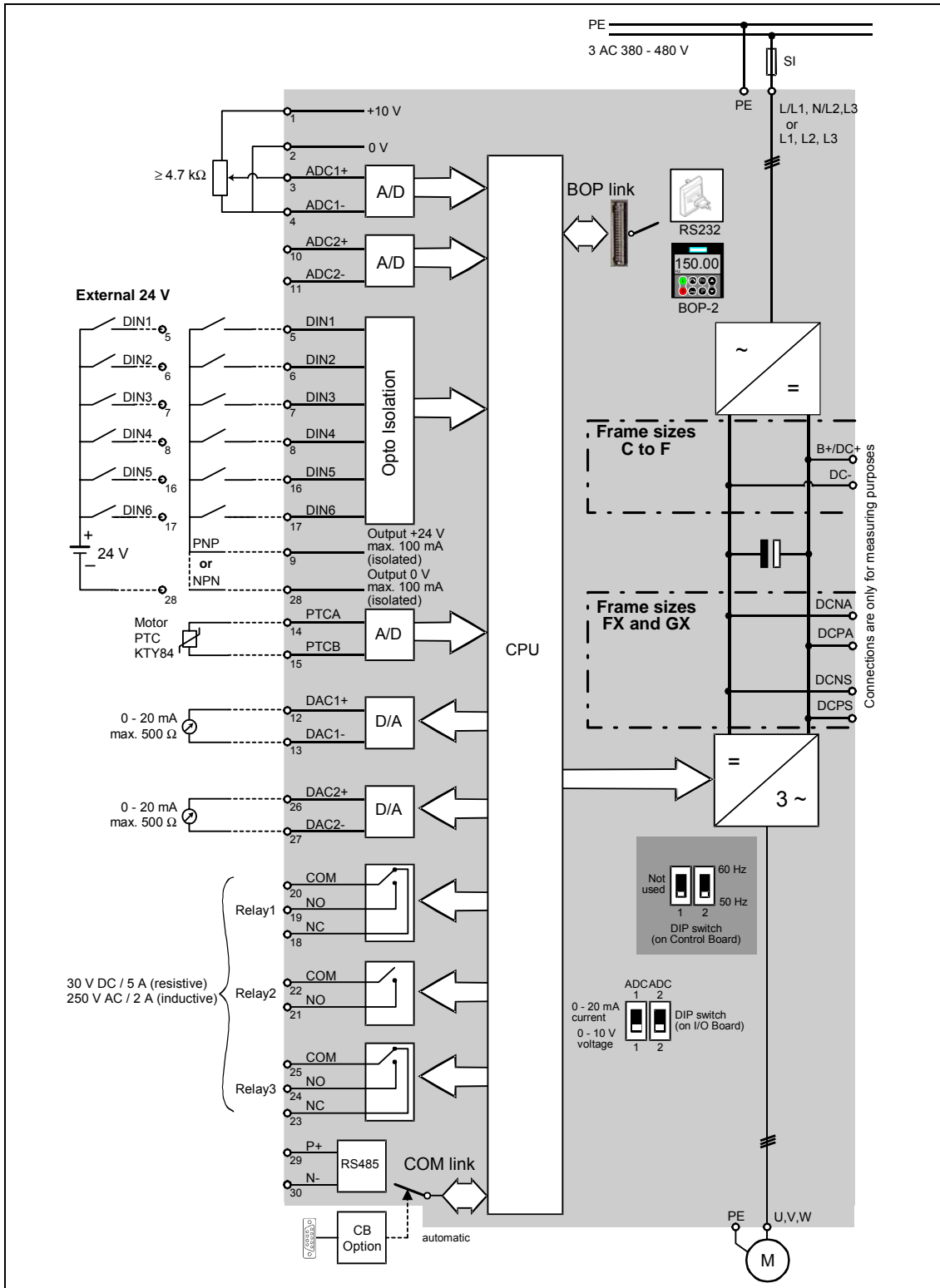

Figure 3-1 Inverter block diagram

3.1.1 Standard settings for the terminals

See Figure 3-2.

3.1.2 Analogue inputs

Analogue input 1 (AIN1) can be used with:

0 - 10 V, 0 - 20 mA and -10 V to +10 V

Analogue input 2 (AIN2) can be used with:

0 - 10 V and 0 - 20 mA

The analog input circuit can be alternatively configured to provide additional digital inputs (DIN7 & DIN8) as shown:

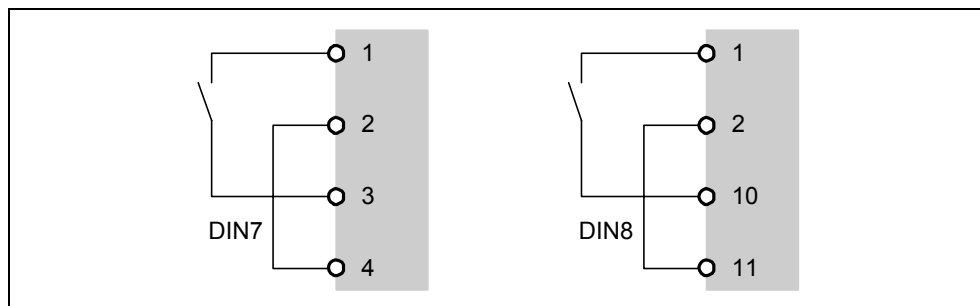

Figure 3-2 Configuration of the analogue input as a digital input

When an analogue input is configured as a digital input the threshold values are as follows:

1.75 V DC = OFF

3.70 V DC = ON

Terminal 9 (24 V) can also be used to drive the analog inputs when used as digital inputs. Terminals 2 and 28 (0 V) must be linked together.

3.2 Commission modes

In the standard version, the MICROMASTER 430 is fitted with the Status Display Panel (SDP) (see Figure 3-3) with which it is possible to use the inverter with the pre-assigned factory settings for a large range of applications. If these factory settings are not suitable, you can adapt them to suit your equipment conditions using the Basic Operator Panel-2 (BOP-2) (see Figure 3-3). The BOP-2 are available as options. You can also adjust the factory settings using the PC IBN tool. This software is available on the CD ROM which comes with the documentation of the unit.

ATTENTION

MICROMASTER 430 can only be operated with the BOP-2.
It is not possible to use BOP or AOP.

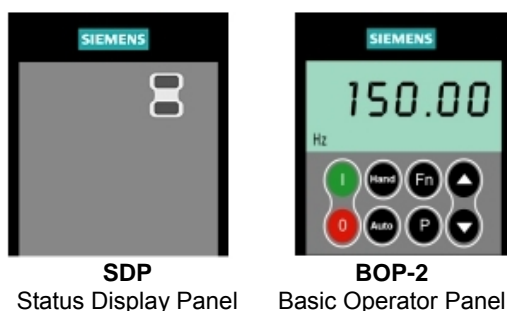

Figure 3-3 Panels available for the MICROMASTER 430 Inverter

For notes on replacing the operator panels please refer to the corresponding appendix A to this manual.

NOTICE

Adjusting the motor frequency 50/60 Hz: The DIP switch to adjust the motor frequency is located below the I/O board (for removing the I/O board, see appendix C)

The inverter is delivered as follows:

- DIP switch 2:
 - ◆ Off position: European defaults (50 Hz, kW etc.)
 - ◆ On position: North American defaults (60 Hz, hp etc.)
- DIP switch 1:
 - Not for customer use.

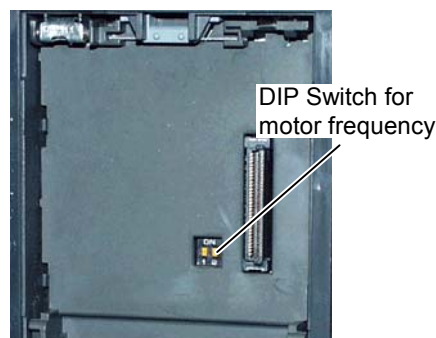
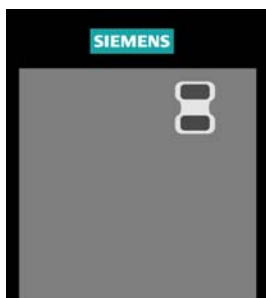

Figure 3-4 DIP switch

3.2.1 Commissioning with the SDP



The SDP has two LEDs on the front which display the current operating status of the inverter (see Section 6.1).

When the SDP is used, the presettings of the inverter must be compatible with the following motor data:

- Rated motor power
- Motor voltage
- Rated motor current
- Rated motor frequency

(A conventional Siemens motor is recommended)

In addition, the following conditions must be met:

- Linear V/f motor speed controlled by an analog potentiometer.
- Maximum speed 1500 rpm at 50 Hz (1800 rpm at 60 Hz); can be controlled by a potentiometer via the analog inputs of the inverter.
- Ramp-up time = 10 s
- Ramp-down time = 30 s

Settings for more complex applications can be found in the parameter list and in Section 3.2.2 "Commission Overview with BOP-2".

Table 3-1 Default settings for operation using the SDP

	Terminals	Parameter	Default Operation
Digital Input 1	5	P0701 = '1'	ON right
Digital Input 2 *	6	P0702 = '12'	Reverse
Digital Input 3	7	P0703 = '9'	Fault Acknowledge
Digital Input 4	8	P0704 = '15'	Fixed Frequency
Digital Input 5	16	P0705 = '15'	Fixed Frequency
Digital Input 6	17	P0706 = '15'	Fixed Frequency
Digital Input 7	Via AIN1	P0707 = '0'	Inactive
Digital Input 8	Via AIN2	P0708 = '0'	Inactive

* The standard setting for the change of rotation direction is as inhibited. (Parameter 1110)

Basic operation with SDP

With the SDP fitted, the following is possible:

- Start and stopping the motor (DIN1 via external switch)
- Fault Reset (DIN3 via external switch)
- Presetting frequency setpoint (via ADC1 with external potentiometer default setting of the ADC: Voltage input)
- Output frequency actual value (via D/A converter, D/A converter output: Current output)

Controlling the speed of the motor is accomplished by connecting the analog inputs as shown in the Figure 3-5. The potentiometer and the external switches can be connected through the drive inverter internal power supply.

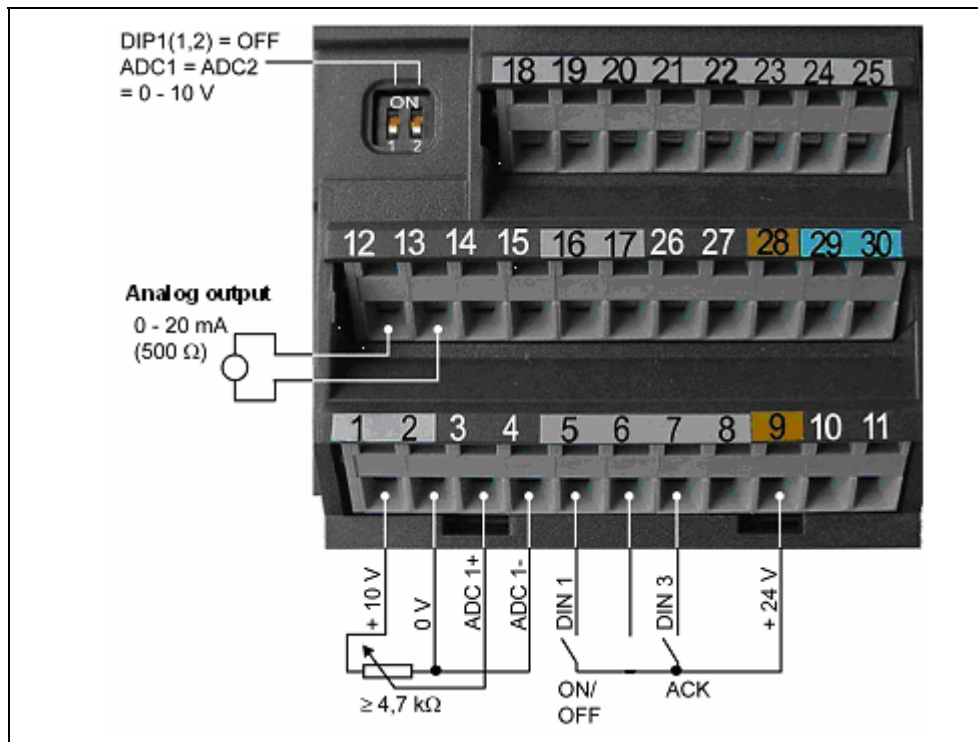

Figure 3-5 Recommended wiring for the factory setting

If settings have to be made which go beyond the factory setting, then depending on the complexity of the application, when commissioning the drive system, the particular function description as well as the parameter list including function charts must be carefully taken into consideration.

3.2.2 Commission Overview with BOP-2

Prerequisites

Mechanical and electrical Installation are completed.

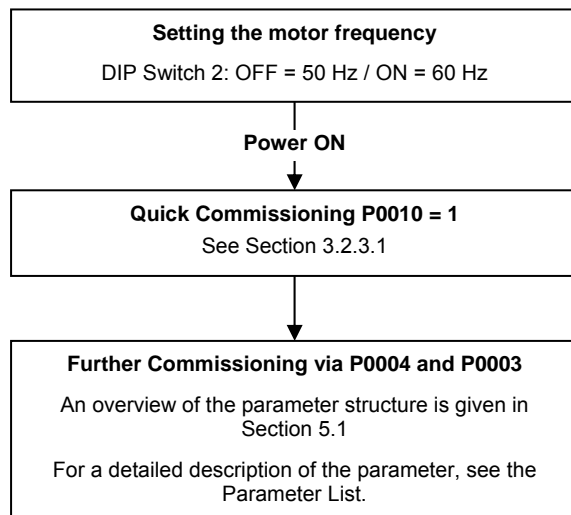

NOTES

We recommend the commissioning according this scheme.

3.2.2.1 Commissioning with the BOP-2

You can alter parameter values via the BOP-2. To set parameters on this panel, you must remove the SDP and attach the BOP-2 (see Appendix A).



The BOP-2 features a five-digit, seven-segment display for showing parameter numbers and values, alarm and fault messages and setpoints and actual values. Parameter sets cannot be saved via the BOP-2.

Table 3-2 shows the factory default settings for operation via the BOP-2.

NOTICE

- The BOP-2 motor control functions are disabled by default. To control the motor via the BOP-2, parameter P0700 should be set to 1 and P1000 set to 1.
- The BOP-2 can be fitted to and removed from the inverter whilst power is applied.
- If the BOP-2 has been set as the I/O control (P0700 = 1), the drive will stop if the BOP-2 is removed.

Table 3-2 Default settings for operation using the BOP-2

Parameter	Meaning	Default Europe (North America)
P0100	Operating Mode Europe/US	50 Hz, kW (60 Hz, hp)
P0307	Power (rated motor)	Dimension kW (Hp) depending on setting of P0100. [Value depending on variant]
P0310	Motor frequency rating	50 Hz (60 Hz)
P0311	Motor speed rating	1395 (1680) rpm [depending on variant]
P1082	Maximum Motor Frequency	50 Hz (60 Hz)

ATTENTION

MICROMASTER 430 can only be operated using a BOP-2 bedient werden.

If a BOP or AOP is used, the following is shown on the display -----.

Buttons on the BOP-2

















Panel/Button	Function	Effects
	Indicates Status	The LCD displays the settings currently used by the converter.
	Start motor	Pressing the button starts the converter. This button is disabled by default. To enable this button set P0700 = 1.
	Stop motor	OFF1 Pressing the button causes the motor to come to a standstill at the selected ramp down rate. Disabled by default; to enable set P0700 = 1. OFF2 Pressing the button twice (or once long) causes the motor to coast to a standstill. This function is always enabled.
	Manual mode	The customer terminal strip (CD S2) and the operating panel (BOP-2) are sources for commands and set values
	Automatic mode	The customer's terminal strip (CD S1) or the serial (US S) or field bus interface (e.g. PROFIBUS) are sources for commands and set values.
	Functions	This button can be used to view additional information. Pressing and holding the button for 2 seconds from any parameter during operation, shows the following: 1. DC link voltage (indicated by d – units V). 2. Output current. (A) 3. Output frequency (Hz) 4. Output voltage (indicated by o – units V). 5. The value selected in P0005 (If P0005 is set to show any of the above (1 - 4) then this will not be shown again). Additional presses will toggle around the above displays. Jump Function From any parameter (rXXXX or PXXXX) a short press of the Fn button will immediately jump to r0000, you can then change another parameter, if required. Upon returning to r0000, pressing the Fn button will return you to your starting point. Quit In case of a fault or alarm the  button resets the fault or alarm message on the operator panel display.
	Access parameters	Pressing this button allows access to the parameters.
	Increase value	Pressing this button increases the displayed value.
	Decrease value	Pressing this button decreases the displayed value.

Figure 3-6 Buttons on the BOP-2

Changing parameters with the BOP-2

The procedure for changing the value of parameter P0004 is described below. Modifying the value of an indexed parameter is illustrated using the example of P0719. Follow exactly the same procedure to alter other parameters that you wish to set via the BOP-2.

Changing P0004 – parameter filter function

Step	Result on display
1 Press  to access parameters	r 0000
2 Press  until P0004 is displayed	P0004
3 Press  to access the parameter value level	0
4 Press  or  to the required value	7
5 Press  to confirm and store the value	P0004

Changing P0719 an indexed parameter Selection of command/setpoint source









Step	Result on display
1 Press  to access parameters	r 0000
2 Press  until P0719 is displayed	P0719
3 Press  to access the parameter value level	r 0000
4 Press  to display current set value	0
5 Press  or  to the required value	12
6 Press  to confirm and store the value	P0719
7 Press  until r0000 is displayed	r 0000
8 Press  to return the display to the standard drive display (as defined by the customer)	

Figure 3-7 Changing parameters via the BOP-2





NOTES

In some cases - when changing parameter values - the display on the BOP-2 shows **buSY**. This means the inverter is busy with tasks of higher priority.

Changing single digits in Parameter values

For changing the parameter value rapidly, the single digits of the display can be changed by performing the following actions:

Ensure you are in the parameter value changing level (see "Changing parameters with BOP-2").

1. Press  (function button), which causes the right hand digit to blink.
2. Change the value of this digit by pressing  / .
3. Press  (function button) again causes the next digit to blink.
4. Perform steps 2 to 4 until the required value is displayed.
5. Press the  to leave the parameter value changing level.

NOTES

The function button may also be used to acknowledge a fault condition

3.2.3 Commissioning functions with BOP-2**3.2.3.1 Quick commissioning (P0010=1)**

Mechanical and electrical installation of the inverter must be completed before running „Quick Commissioning“.

It is **important** that parameter P0010 is used for commissioning and P0003 is used to select the access level.

There are three user levels, standard, extended and expert. The lower the access level fewer parameters can be seen while performing Quick commissioning. The values for these parameters are either the default settings or are calculated during quick commissioning.

Quick commissioning includes motor and ramp setting parameters.

Quick Commissioning concludes with P3900, which, when set to 1, will perform the necessary motor calculations and clear all other parameters (not included in P0010=1) to the default settings. After completing Quick Commissioning with P3900 = 1, the inverter is then ready to run; this will only happen in the Quick Commissioning mode.

Flow chart Quick Commissioning

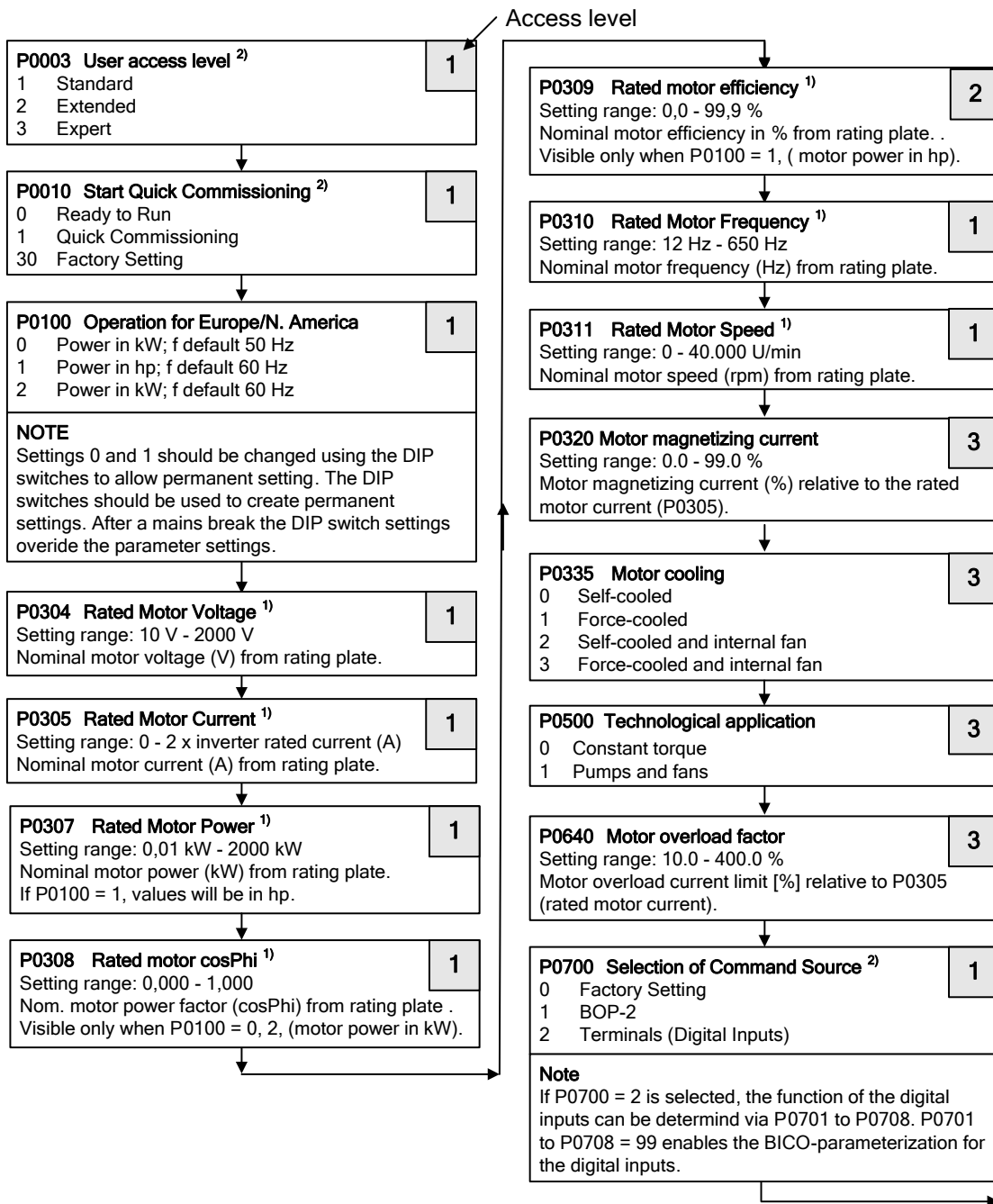

1) Motor-specific parameters – see motor rating plate.
 2) The parameters offer more setting options than listed here. See Parameter List for further setting options.

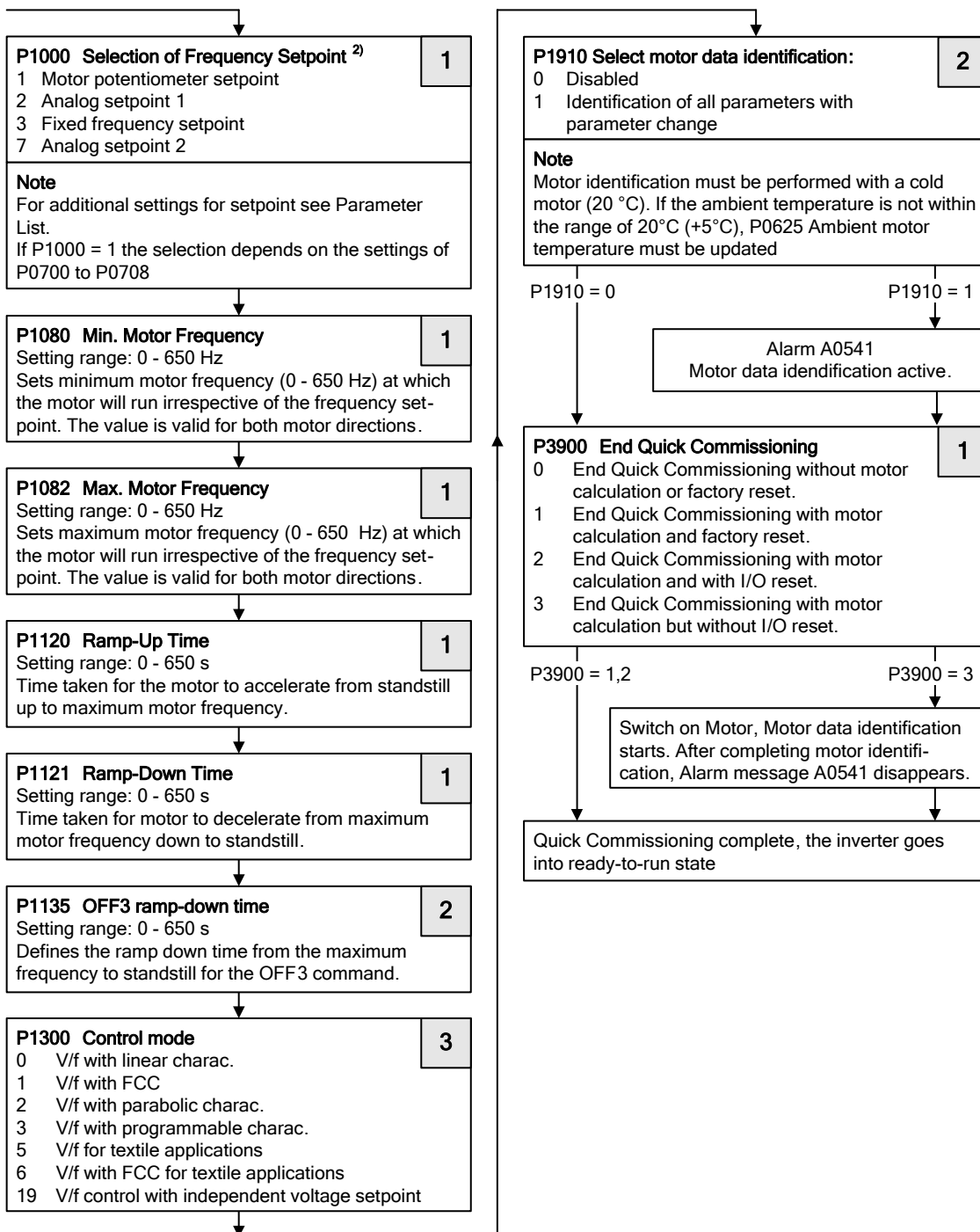

2) The parameters offer more setting options than listed here. See Parameter List for further setting options.

Motor data for parameterization

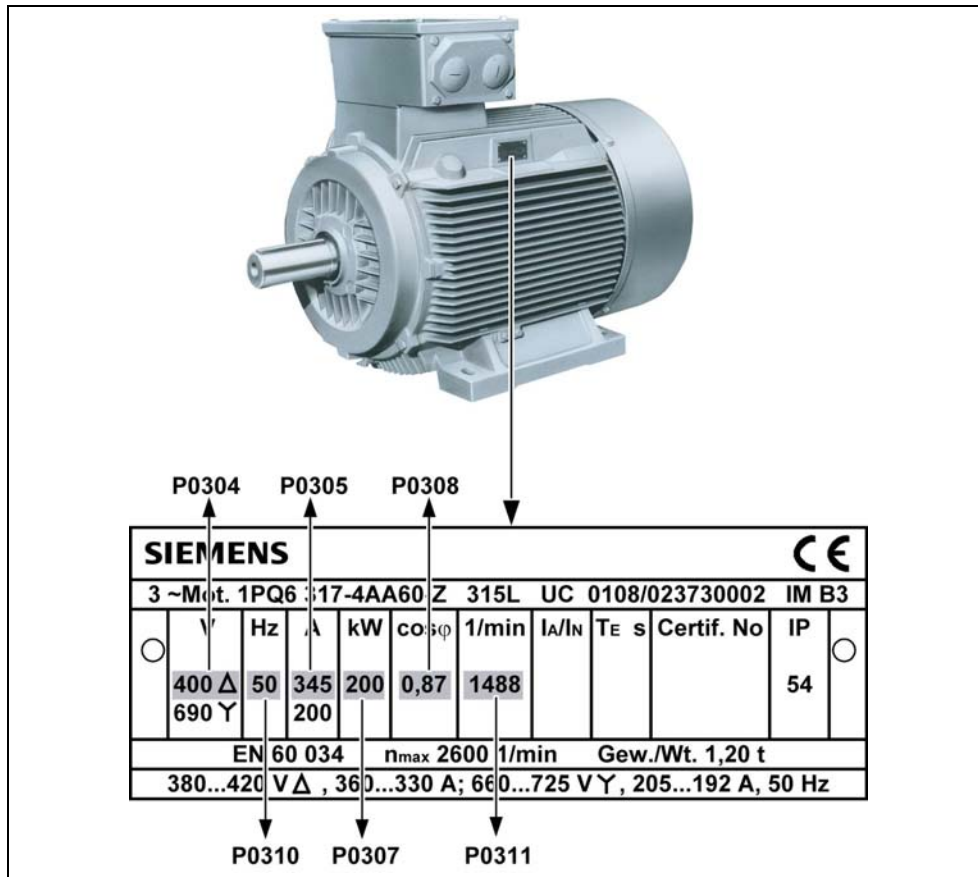

Figure 3-8 Typical Motor Rating Plate Example
(The details given on the rating plate are only examples)

NOTICE

- P0308 & P0309 are only visible if P0003 ≥ 2. Only one of the parameters is shown depending on the settings of P0100.
- P0307 indicates kW or HP depending upon the setting of P0100. For detailed information, please see the Parameter List.
- Changing motor parameters is not possible unless P0010=1.
- Ensure that the inverter is configured correctly to the motor.
- Observe the motor's star/delta connection arrangement!

3.2.4 Reset to Factory default

To reset all parameters to the factory default settings; the following parameters should be set as follows (BOP-2 or Communication Option needed):

1. Set P0010=30.
2. Set P0970=1.

NOTE

The reset process can take up to 3 minutes to complete.

3.3 General operation

For a full description of standard and extended parameters, please refer to the Parameter List.







NOTICE

1. The inverter does not have a main power switch and is live when the mains supply is connected. It waits, with the output disabled, until the RUN button is pressed or for the presence of a digital ON signal at terminal 5 (rotate right).
 2. If a BOP-2 is fitted and the output frequency is selected to be displayed (P0005 = 21) the corresponding setpoint is displayed approximately every 1.0 seconds while the inverter is stopped.
 3. The inverter is programmed at the factory for standard applications on Siemens four-pole standard motors that have the same power rating as the inverters. When using other motors it is necessary to enter the specifications from the motor's rating plate. See Figure 3-8 for details on how to read motor data.
 4. Changing motor parameters is not possible unless P0010 = 1.
 5. Before initiating a run, You must set P0010 back to 0.
-

Basic operation with the BOP-2

Prerequisites

- P0010 = 0 (in order to initiate the run command correctly).
 - P0700 = 1 (enables the start/stop button on the BOP-2).
 - P1000 = 1 (this enables the motor potentiometer setpoints).
-

1. Press the green Button  to start the motor.
 2. Press the Button  while the motor is turning. Motor speed increases to 50 Hz.
 3. When the inverter reaches 50 Hz, press the Button . Motor speed and display is decreased.
 4. Press button , to activate manual mode.
 5. Press button , to activate automatic mode.
 6. The red button stops the motor .
-

NOTE

Three Command data sets (CDS) are available. The Hand/Auto-Button on the BOP-2 toggles between CDS 1 and CDS 2. If CDS 3 is selected (via P0811), the Hand/Auto-Button on the BOP-2 is inactive. For further details see the Parameter List.

External motor thermal overload protection

When operated below rated speed, the cooling effect of fans fitted to the motor shaft is reduced. Consequentially, most motors require de-rating for continuous operation at low frequencies. To ensure that the motors are protected against overheating under these conditions, a PTC temperature sensor must be fitted to the motor and connected to the inverter control terminals.

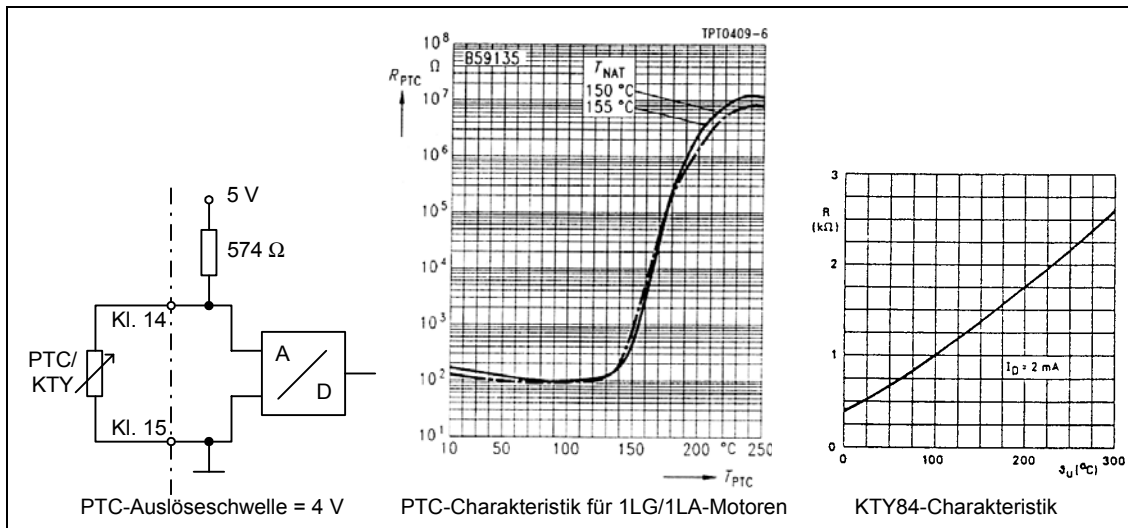

Figure 3-9 Thermal overload protection

With PTC sensor (P0601 = 1)

If the PTC in the motor is connected to the MICROMASTER 430 control terminals 14 (PTCA) and 15 (PTCB) and the PTC function enabled by setting P0601 = 1, then the MICROMASTER 430 will operate as normal providing the resistance at the terminals remains below approximately 1500 Ω. If this value is exceeded, the inverter indicates a warning A0511 and then a fault F0011. The actual resistance value at which this occurs will not be less than 1000 Ω, and not more than 2000 Ω.

With KTY84 sensor (P0601 = 2)

The KTY84 has to be connected so that the diode is forward biased; that is the anode is connected to terminal 14 (PTCA) and the cathode to terminal 15 (PTCB). If the temperature monitoring function is enabled by setting P0601 = 2, the temperature of the sensor (and therefore the motor windings) is written to parameter r0035. The threshold motor temperature can now be set using parameter P0604 (default setting 130 °C).

Connection failure

If the connection to the PTC or KTY84 sensor becomes open circuit or short circuit, a fault will be indicated, and by default the drive will trip.

4 MICROMASTER 430 functions

This chapter contains:

- a description of the different procedures to control the inverter
- a summary of the control types of the inverter.

4.1	Frequency set point (P1000)	63
4.2	Command sources (P0700).....	63
4.3	OFF and brake function	64
4.4	Control modes (P1300).....	65
4.5	MICROMASTER 430 operating modes	66
4.6	Free Function Blocks (P2800 ff)	70
4.7	Faults and Alarms	70



WARNING

- ◆ When operating electrical devices, certain parts of these devices are always live.
 - The following terminals can carry dangerous voltages even if the inverter is inoperative:
 - ◆ the power supply L/L1, N/L2, L3 resp. U1/L1, V1/L2, W1/L3
 - ◆ the motor terminals U, V, W resp. U2, V2, W2
 - ◆ and depending on the frame size the terminals DC+/B+, DC-, B-, DC/R+ resp. DCPS, DCNS, DCPA, DCNA
 - ◆ Emergency Off devices in compliance with EN 60204 IEC 204 (VDE 0113) must remain functional in all operating modes of the control device. Resetting the Emergency Off device must not result in uncontrolled or undefined re-starts.
 - ◆ In those cases, where short circuits in the control device can result in considerable material damage or even serious bodily harm (i.e. potentially dangerous short circuits), external measures or devices must be taken or fitted to ensure that operation is not dangerous even if a short circuit does occur (e.g. independent limit switches, mechanical locks etc.).
 - ◆ MICROMASTER inverters work with high voltages.
 - ◆ Certain parameter settings can cause the inverter to start up again automatically after the supply voltage has failed.
 - ◆ The motor parameters must be configured exactly to ensure perfect motor overload protection.
 - ◆ The device provides an internal motor overload protection system in compliance with UL508C, section 42. See P0610 and P0335, the pre-setting for i^2t is ON. Motor overload protection can also be secured via an external KTY84 or PTC.
 - ◆ This equipment is suitable for use in a circuit capable of delivering not more than 10,000 (Frame Size C) or 42,000 (Frame Sizes D to GX) symmetrical amperes (rms), for a maximum voltage of 460 V when protected by an H, J or K type fuse, a circuit breaker or self-protected combination motor controller (for more details see Appendix F).
 - ◆ This device must not be used as an „Emergency Off device“ (see EN 60204, 9.2.5.4).
-

4.1 Frequency set point (P1000)

- Pre-setting: terminal 3/4 (AIN+/ AIN -, 0...10 V equivates to 0...50/60 Hz)
- Additional settings: see P1000

4.2 Command sources (P0700)

ATTENTION

The **ramp-up /ramp-down times** and **ramp smoothing** also have an effect on the motor's start and stop behaviour. Further details about these functions are to be found in the parameter list for parameters P1120, P1121, P1130 – P1134.

Start motor

- Default: terminal 5 (DIN1, high)
- Additional settings: see P0700 to P0708

Stop motor

- There are a number of possibilities to stop the motor:
- Default :
 - ◆ OFF1 terminal 5 (DIN1, low)
 - ◆ OFF2 OFF key on BOP-2, press the OFF key once for 2 seconds or press twice
 - ◆ OFF3 not active in factory settings
- Additional settings: see P0700 to P0708

Reversing the direction of rotation of the motor

This function is inhibited in the factory settings. To release it, you must set P1110 = 0.

- Default: terminal 6 (DIN2, high)
- Additional settings: see P0700 to P0708

4.3 OFF and brake function

4.3.1 OFF1

This command (which is triggered by the cancellation of the ON order) causes the inverter to come to a standstill within the selected ramp-down time.

For parameters to change ramp-down time: see P1121

ATTENTION

- The ON and the subsequent OFF command must come from the same source.
 - If the ON / OFF1 command is set for more than one digital input, only the digital input set last will be valid, e.g. DIN3 is active.
 - OFF1 can be combined with DC braking or compound braking.
-

4.3.2 OFF2

This command causes the motor to run down freely to a standstill (impulses deactivated).

ATTENTION

The OFF command can have one or more sources. The default causes the OFF2 command to be set to BOP-2. This source continues to exist even if other sources are defined by **one** of the parameters P0700 to P0708.

4.3.3 OFF3

The OFF3 command causes the motor to be slowed down quickly.

The binary input must be closed to start the motor if the command OFF3 has been set. If OFF3 is closed, the motor can be started and stopped by commands OFF1 or OFF2.

If OFF3 is open, the motor cannot be started..

- ramp-down time: see P1135
-

ATTENTION:

OFF3 can be combined with DC braking, compound braking or dynamic braking.

4.3.4 DC braking

DC braking is possible together with OFF1 and OFF3. Direct current is input which brakes the motor quickly and holds the shaft until the end of the braking period.

- Activate DC braking: see P0701 to P0708
 - Set DC brake period: see P1233
 - Set DC braking current: see P1232
 - Set DC braking start frequency: see P1234
-

ATTENTION

If no digital input is set to DC braking, DC braking is active for P1233 ≠ 0 after every OFF1 command with the period set in P1233.

4.3.5 Compound braking

Compound braking is possible with OFF1 and OFF3. In the case of compound braking, a DC component is superimposed on the alternating current.

Set braking current : see P1236

4.4 Control modes (P1300)

MICROMASTER 430 has a number of different control modes based on U/f-control. The individual modes have been listed below, additional settings are listed in the parameter list and the function plans contained therein.

- **Linear U/f control** **P1300 = 0**
Can be used for variable and constant torque applications e.g. transport systems and positive displacement pumps.
- **Linear U/f control with flux current control (FCC)** **P1300 = 1**
This type of control can be used to improve the performance and dynamic behaviour of the motor.
- **Parabolic U/f control** **P1300 = 2**
This type of control can be used for variable torque loads e.g. fan and pumps.
- **Multiple point U/f control** **P1300 = 3**
Please refer to the MICROMASTER 430 parameter list for more information on this operating mode.
- **U/f control for textile applications** **P1300 = 5**
There is no slip compensation gain or resonance dampening. The I_{max} controller refers to voltage instead of frequency.
- **U/f control with FCC for textile applications** **P1300 = 6**
A combination of P1300 = 1 and P1300 = 5.
- **U/f control with independent voltage set point** **P1300 = 19**
Using the P1330, the voltage set point can be given independently from the starting frequency of the ramp function generator (HLG).

4.5 MICROMASTER 430 operating modes

4.5.1 Bypass Mode

Setting up an inverter bypass circuit

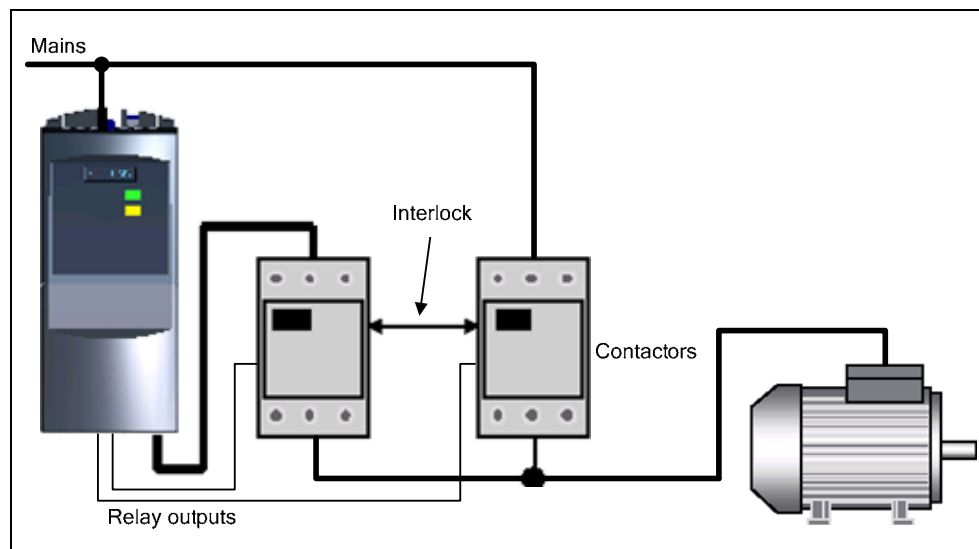

Figure 4-1 Bypass circuit

Function

Control of two interlocked contactors via relay outputs of MICROMASTER 430. This circuit makes it possible to operate the motor via the inverter or directly via the mains. The inverter is responsible for switching.

Switching is possible by the following means:

- error message from the inverter
- digital input
- inverter frequency

For further settings please refer to parameters list P1260 and following.

4.5.2 Belt Failure Detection

Recognizes mechanical faults in drive section e.g. torn V-belt, pumps which have run dry etc.

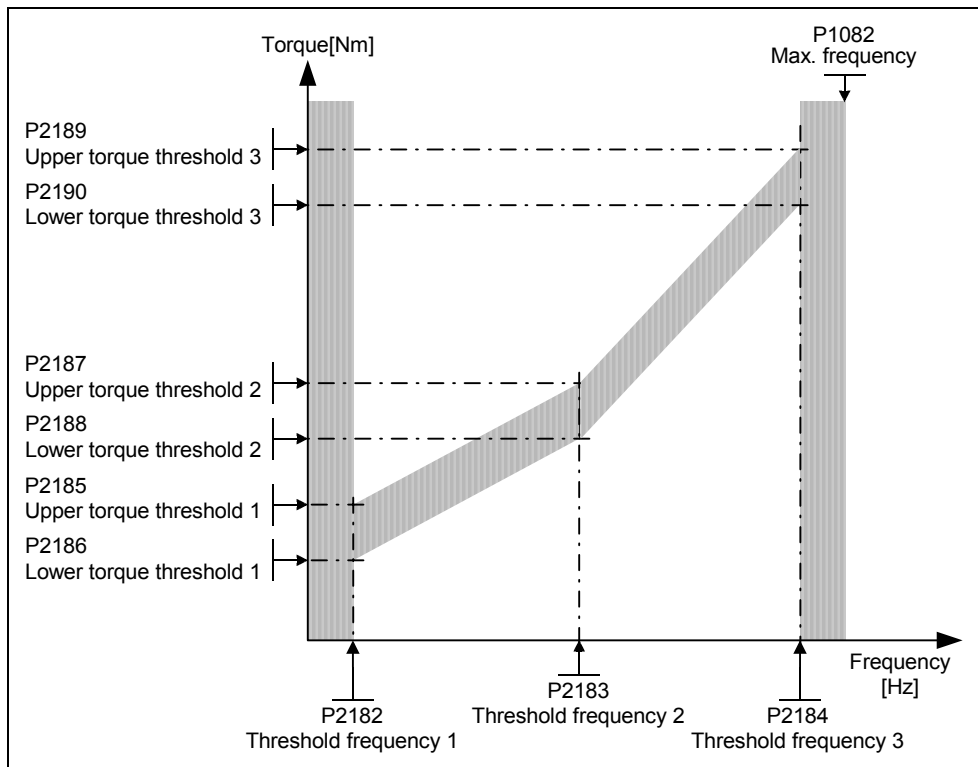

Figure 4-2 Belt Failure Detection

Function

A torque band is monitored. This enables underload and overload conditions to be recognized (e.g. ventilator not running correctly)

Comparison between current speed / torque curve with programmed envelope curve. The upper and lower frequency curve can be specified via three supporting points each. In addition a dead time until the function is triggered can be defined. This avoids accidental triggering due to transient events.

For additional settings please refer to parameter list P2181 and following.

4.5.3 Motor Staging

Controlling additional drives via output relay

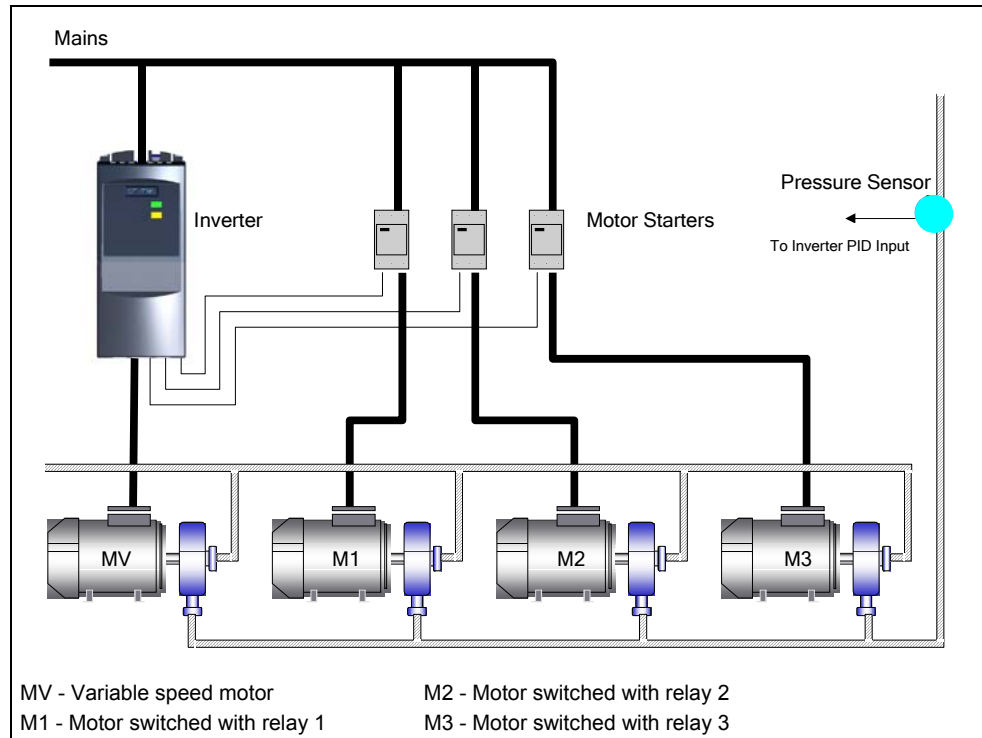

Figure 4-3 Motor Staging

Function

Enables up to three additional motors to be controlled based on PID control

The entire system is made up of a pump which is controlled by the inverter with up to an additional 3 pumps which can be added to the system via contactors or motor starters. The motor starter is controlled via the output relay in the inverter. Figure 4-3 shows a typical pump system.

This function can also be used accordingly for ventilators and ventilation shafts.

For additional settings please refer to parameter list P2370 and following.

4.5.4 Energy Saving Mode

Energy saving mode to switch off the motor when it is in idle mode

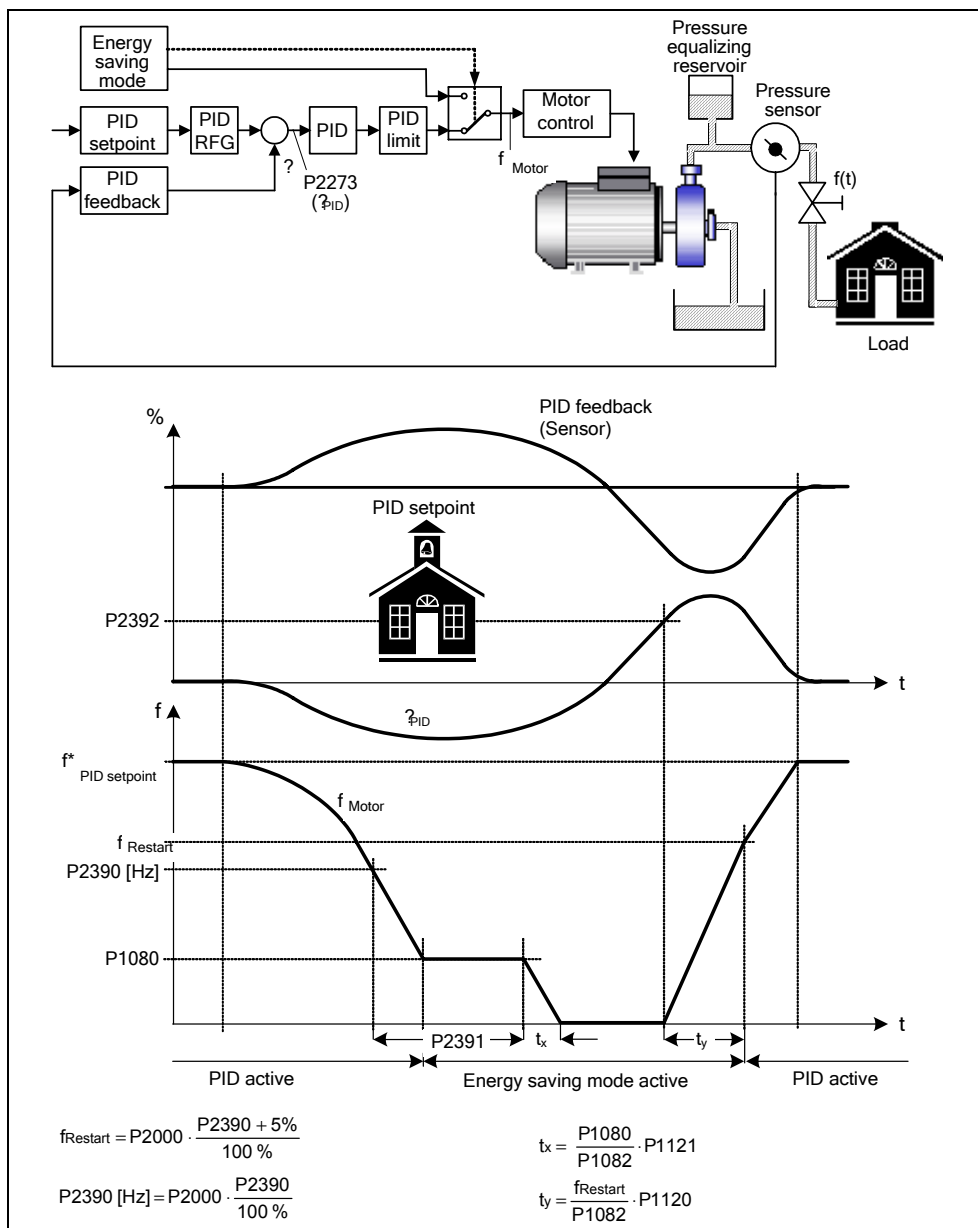

Figure 4-4 Energy Saving Mode

Function

Energy saving mode extends the function of the PID controller. This enables the motor to be operated for a defined period of time with a minimum frequency and to switch it off afterwards. If the re-start frequency is reached, the motor is automatically re-started again. Energy saving mode is independent of the Motor Staging Function. It is possible to combine Motor Staging and Energy Saving Mode. For additional settings please refer to the parameter list P2390 and following.

4.6 Free Function Blocks (P2800 ff)

Using free function blocks, internal signals (Digital inputs, set points, actual values, ...) can be interlinked, to enable application specific control.

4.7 Faults and Alarms

SDP

With the SDP Faults and Alarms conditions are displayed via the two LEDs on the SDP. For further information see Section 6.1 on page 76.

The operation status of the inverter is indicated by the two LEDs as follows:

- Green and yellow = Ready to run
- Green only = Inverter running

BOP-2

If a BOP-2 has been fitted to the inverter, details of any fault condition will be displayed by the operator panel. For detailed information of fault conditions and alarms, See Section 6 parameter list.

5 System parameters

This Chapter contains:

- An overview of the parameter structure of the MICROMASTER 430
- A parameter list in short form

5.1	Introduction to MICROMASTER system parameters	72
5.2	Parameter overview	73

5.1 Introduction to MICROMASTER system parameters

The parameters can only be changed by using the BOP-2 or the Serial Interface.

Parameters can be changed and set using the BOP-2 to adjust the desired properties of the inverter, such as ramp times, minimum and maximum frequencies etc. The parameter numbers selected and the setting of the parameter values are indicated on the optional five-digit LCD display.

- rxxxx indicates a display parameter, Pxxxx a setting parameter.
- P0010 initiates “quick commissioning”.
- The inverter will not run unless P0010 is set to 0 after it has been accessed. This function is automatically perform if P3900 > 0.
- P0004 acts as a filter, allowing access to parameters according to their functionality.
- If an attempt is made to change a parameter that cannot be changed in this status, for example, cannot be changed whilst running or can only be changed in quick commissioning, then **-----** will be displayed.
- **Busy Message**
In some cases - when changing parameter values - the display on the BOP-2 shows **buSY** for maximum of five seconds. This means the inverter is busy with tasks of higher priority.

ATTENTION

MICROMASTER 430 can only be operated using a BOP-2. If the BOP or AOP is used, the following is displayed **-----**.

5.1.1 Access Levels

There are three access levels available to the user; Standard, Extended and Expert. The level of access is set by parameter P0003. For most applications, Standard (P0003 = 1) or Extended parameters (P0003 = 2) are sufficient.

CAUTION

Some of level 4 parameters are for internal system settings only and should not be modified.

Level 4 parameters should only be modified by authorized personnel.

The number of parameters that appear within each functional group depends on the access level set in parameter P0003. For further details regarding parameters, see the Parameter List on the Documentation CD-ROM.

5.2 Parameter overview

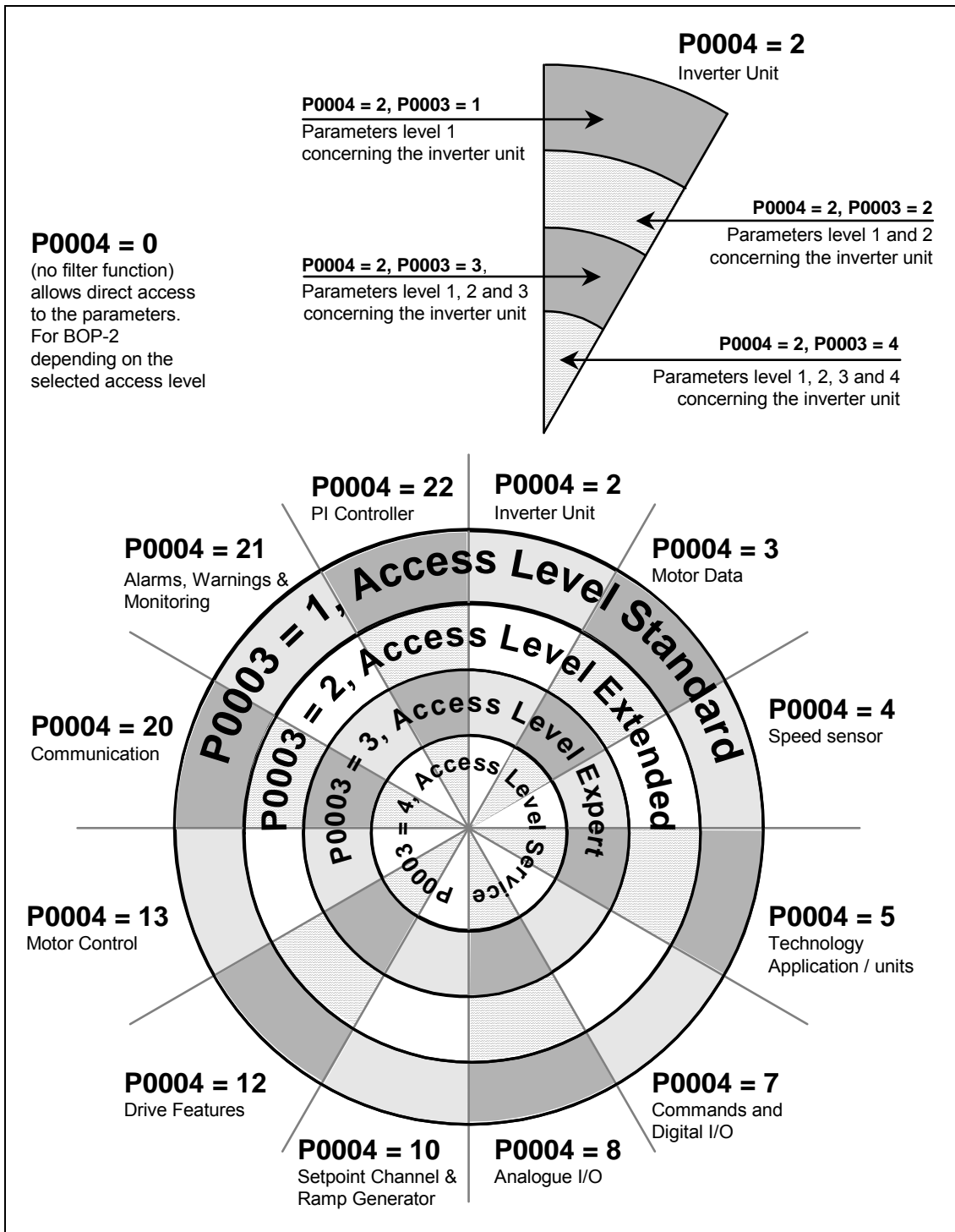

Figure 5-1 Parameter Overview

6 Troubleshooting

This Chapter contains:

- An overview of the operating statuses of the inverter with the SDP
- Notes on troubleshooting with the BOP-2
- A list of the alarms and fault messages

6.1	Troubleshooting with the SDP	76
6.2	Troubleshooting with the BOP-2.....	77
6.3	Fault messages.....	78
6.4	Alarm Messages	78



WARNING

Repairs on equipment may only be carried out by **Siemens Service**, by repair centers **authorized by Siemens** or by qualified personnel who are thoroughly acquainted with all the warnings and operating procedures contained in this manual.

Any defective parts or components must be replaced using parts contained in the relevant spare parts list.

Disconnect the power supply before opening the equipment for access.

6.1 Troubleshooting with the SDP

Table 6-1 explains the meaning of the various states of the LEDs on the SDP.

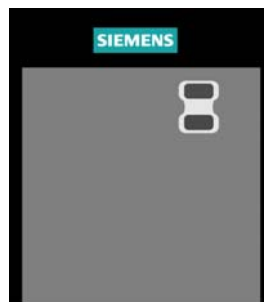

- LEDs for indicating the drive state
- Off
- ☀ On
- ⦿ approx. 0,3 s, flashing
- ⦿ approx. 1 s, twinkling

Table 6-1 Inverter conditions indicated by the LEDs on the SDP

●	Mains not present	☀	Fault inverter temperature
☀	Ready to run	⦿	Warning current limit - both LEDs twinkling same time
●	Inverter fault - other than the ones listed below	⦿	Other warnings - both LEDs twinkling alternatively
☀	Inverter running	⦿	Undervoltage trip / undervoltage warning
●	Fault overcurrent	⦿	Drive is not in ready state
⦿	Fault overvoltage	⦿	ROM failure - Both LEDs flashing same time
⦿	Fault motor overtemperature	⦿	RAM failure - Both LEDs flashing alternatively

6.2 Troubleshooting with the BOP-2

Warnings and faults are displayed on the BOP-2 with Axxx and Fxxx respectively. The individual messages are shown in Section 6.3.

If the motor fails to start when the ON command has been given:

- Check that P0010 = 0.
- Check that a valid ON signal is present.
- Check that P0700 = 2 (for digital input control) or P0700 = 1 (for BOP-2 control).
- Check that the setpoint is present (0 to 10V on Terminal 3) or the setpoint has been entered into the correct parameter, depending upon the setpoint source (P1000). See the Parameter List for further details.

If the motor fails to run after changing the parameters, set P0010 = 30 then P0970 = 1 and press **P** to reset the inverter to the factory default parameter values.

Now use a switch between terminals **5** and **9** on the control board. The drive should now run to the defined setpoint by analogue input.

NOTICE

Motor data must relate to the inverter data power range and voltage.

6.3 Fault messages

In the event of a failure, the inverter switches off and a fault code appears on the display.

NOTE

To reset the fault code, one of three methods listed below can be used:

1. Cycle the power to the drive.
 2. Press the  button on the BOP-2.
 3. Via Digital Input 3 (default setting)
-

Fault messages are stored in parameter r0947 under their code number (e.g. F0003 = 3). The associated error value is found in parameter r0949. The value 0 is entered if a fault has no error value. It is furthermore possible to read out the point in time that a fault occurred (r0948) and the number of fault messages (P0952) stored in Parameter r0947.

A detailed description of the fault messages is provided in the parameter list.

6.4 Alarm Messages

Alarm messages are stored in parameter r2110 under their code number (e.g. A0503 = 503) and can be read out from there.

A detailed description of the alarm messages is provided in the parameter list.

7 MICROMASTER 430 specifications

This Chapter contains:

- Table 7.1 contains the general technical specifications for the MICROMASTER 430 inverter
- Table 7-2 contains terminal tightening torques and the required cooling air flow
- Table 7-3 contains current values depending on pulse frequency
- Table 7-4 includes various tables of specific technical data for individual MICROMASTER 430 inverters

Table 7-1 MICROMASTER 430 Performance Ratings

Feature	Specification
Mains Operating Voltage & Power Ranges VT	3 AC 380 to 480 V \pm 10 % 7.50 kW – 90.0 kW (10.0 hp – 120 hp)
Input Frequency	47 to 63 Hz
Output frequency	0 Hz to 650 Hz
Power Factor	\geq 0.7
Inverter Efficiency	Frame Sizes C to F: 96 % to 97 % Frame Sizes FX and GX: 97 % to 98 %
Overload Capability for variable torque (VT)	Frame Sizes C to F: 1.1 x Nominal output current (i.e. 110 % overload) for 60 s every 300 s and 1.4 x Nominal output current (i.e. 140 % overload) for 3 s every 300 s Frame Sizes FX and GX: 1.1 x Nominal output current (i.e. 110% overload) for 59 s every 300 s and 1.5 x Nominal output current (i.e 150% overload) for 1 s every 300s
Inrush Current	Less than rated input current
Power-ON-OFF cycle time	Frame Sizes C to E: every 30 s Frame Size F: every 150 s Frame Sizes FX and GX: every 300 s
Control Method	Linear V/f control, Linear V/f control with FCC, Parabolic V/f control, Multi-point V/f control, V/f control for textile applications, V/f control with FCC for textile applications, V/f control with independent voltage setpoint
Pulse Frequency	Frame Sizes C to F: 2 kHz to 8 kHz (2 kHz steps) Frame Sizes FX and GX: 2 kHz to 8 kHz (2 kHz steps) (Standard 2 kHz (VT), power reduction see Table 7-3)
Fixed Frequencies	15, programmable
Skip Frequencies	4, programmable
Setpoint Resolution	0.01 Hz Digital, 0.01 Hz Serial, 10 bit Analogue (motor potentiometer 0.1 Hz [0.1% (in PID mode)])
Digital Inputs	6, programmable (isolated), switchable active high / active low (PNP/NPN)
Analog Input 1	0 - 10 V, 0 - 20 mA and -10 V to +10 V
Analog Input 2	0 - 10 V and 0 - 20 mA
Relay Outputs	3, programmable 30 V DC / 5 A (resistive), 250 V AC 2 A (inductive)
Analogue Output	2, programmable (0 to 20 mA)
Serial Interface	RS-485, optional RS-232
Electromagnetic Compatibility	Frame Sizes C to F: Optional EMC filters to EN 55011 Class A or B, also Internal Class A filters available Frame Sizes FX and GX: With EMI filter (available as an option) the limiting values of the EN 55011, Class A are fulfilled for conducted emission (line commutating choke required).
Braking	DC braking, Compound braking
Protection Level	IP20
Temperature range (VT)	Frame Sizes C to F: -10 °C to +40 °C (14 °F to 104 °F) Frame Sizes FX and GX: 0 °C to +40 °C (32 °F to 104 °F), to 55 °C (131 °F) Power reduction see Figure 2-2
Storage Temperature	-40 °C to +70 °C (40 °F to 158 °F)

Humidity	< 95 % RH – non-condensing
Operational Altitudes	Frame Sizes C to F: Up to 1000 m above sea level without derating Frame Sizes FX and GX: Up to 2000 m above sea level without derating
Protection Features	Undervoltage , Overvoltage, Overload, Ground Faults, Short circuit, Stall Prevention, Motor Blocking Protection, Motor Overtemperature, Inverter Overtemperature, Parameter Interlock
	Frame Sizes C to F: UL, cUL, CE, C-tick Frame Sizes FX and GX: UL (in preparation), cUL (in preparation), CE
CE Marked	Conformity with EC Low Voltage Directive 73/23/EEC and Electromagnetic Compatibility Directive 89/336/EEC

Table 7-2 Dimensions, required cooling air flow and tightening torques for power terminals

Frame Size	B x H x T	Dimensions		Required cooling air flow		Tightening torques for power terminals	
		mm		l/s		Nm	
C	B x H x T	mm	185 × 245 × 195	l/s	54,9	Nm	2,25
		inch	7,28 × 9,65 × 7,68	CFM	116,3	lb _r -ft	1,7
D	B x H x T	mm	275 × 520 × 245	l/s	2 × 54,9	Nm	10 (max.)
		inch	10,82 × 20,47 × 9,65	CFM	2 × 116,3	lb _r -ft	7,4 (max.)
E	B x H x T	mm	275 × 650 × 245	l/s	2 × 54,9	Nm	10 (max.)
		inch	10,82 × 25,59 × 9,65	CFM	2 × 116,3	lb _r -ft	7,4 (max.)
F	B x H x T	mm	350 × 850 mm × 320 Hight with filter 1150	l/s	150	Nm	50
		inch	13,78 × 33,46 × 12,60 Hight with filter 45,28	CFM	317,79	lb _r -ft	36,9
FX	B x H x T	mm	326 × 1400 × 356	l/s	225	Nm	25
		inch	12,80 × 55,12 × 12,83	CFM	478,13	lb _r -ft	18,4
GX	B x H x T	mm	326 × 1533 × 545	l/s	440	Nm	25
		inch	12,80 × 60,35 × 21,46	CFM	935	lb _r -ft	18,4

Table 7-3 Current reduction depending on pulse frequency

Mains voltage	Power [kW]	Output current in A with a switching frequency of;							
		2 kHz	4 kHz	6 kHz	8 kHz	10 kHz	12 kHz	14 kHz	16 kHz
3 AC 400 V	7,5	19,0	19,0	17,1	15,2	13,3	11,4	9,5	7,6
	11,0	26,0	26,0	24,7	23,4	20,8	18,2	15,6	13,0
	15,0	32,0	32,0	28,8	25,6	22,4	19,2	16,0	12,8
	18,5	38,0	38,0	36,1	34,2	30,4	26,6	22,8	19,0
	22	45,0	45,0	40,5	36,0	31,5	27,0	22,5	18,0
	30	62,0	62,0	55,8	49,6	43,4	37,2	31,0	24,8
	37	75,0	75,0	71,3	67,5	60,0	52,5	45,0	37,5
	45	90,0	90,0	81,0	72,0	63,0	54,0	45,0	36,0
	55	110,0	110,0	93,5	77,0	63,3	49,5	41,3	33,0
	75	145,0	145,0	123,3	101,5	83,4	65,3	54,4	43,5
	90	178,0	178,0	138,0	97,9	84,6	71,2	62,3	53,4
	110	205,0	180,4	–	–	–	–	–	–
	132	250,0	220,0	–	–	–	–	–	–
	160	302,0	265,8	–	–	–	–	–	–
200	370,0	325,6	–	–	–	–	–	–	
250	477,0	419,8	–	–	–	–	–	–	

Table 7-4 MICROMASTER 430 Specifications

In order to have a UL compliant installation fuses from the SITOR range with the appropriate current rating must be used.

Input voltage range **3 AC 380 V ... 480 V, ± 10 %**
(with built in Class A Filter)

Order No.	6SE6430-	2AD27-5CA0	2AD31-1CA0	2AD31-5CA0	2AD31-8DA0	2AD32-2DA0	2AD33-0DA0
VT Motor Output Rating	[kW]	7,5	11,0	15,0	18,5	22,0	30,0
	[hp]	10,0	15,0	20,0	25,0	30,0	40,0
Output Power	[kVA]	10,1	14,0	19,8	24,4	29,0	34,3
VT Input Current 1)	[A]	17,3	23,1	33,8	37,0	43,0	59
VT Output Cur. Max.	[A]	19,0	26,0	32,0	38,0	45,0	62,0
Recommended Fuse	[A]	20	32	35	50	63	80
	3NA	3807	3812	3814	3820	3822	3824
Fuses recommended for UL applications	[A]				50	63	80
	3NE	*	*	*	1817-0	1818-0	1820-0
Input Cable Min.	[mm ²]	2,5	4,0	6,0	10,0	10,0	16,0
	[AWG]	14	12	10	8	8	6
Input Cable Max.	[mm ²]	10,0	10,0	10,0	35,0	35,0	35,0
	[AWG]	8	8	8	2	2	2
Output Cable Min.	[mm ²]	2,5	4,0	6,0	10,0	10,0	16,0
	[AWG]	14	12	10	8	8	6
Output Cable Max.	[mm ²]	10,0	10,0	10,0	35,0	35,0	35,0
	[AWG]	8	8	8	2	2	2
Frame Size		C			D		
Weight	[kg]	5,7	5,7	5,7	17,0	17,0	17,0
	[lbs]	12,5	12,5	12,5	37,0	37,0	37,0

Order No.	6SE6430-	2AD33-7EA0	2AD34-5EA0	2AD35-5FA0	2AD37-5FA0	2AD38-8FA0
VT Motor Output Rating	[kW]	37,0	45,0	55,0	75,0	90,0
	[hp]	50,0	60,0	75,0	100,0	120,0
Output Power	[kVA]	47,3	57,2	68,6	83,8	110,5
VT Input Current 1)	[A]	72	87	104	139	169
VT Output Cur. Max.	[A]	75,0	90,0	110,0	145,0	178,0
Recommended Fuse	[A]	100	125	160	160	200
	3NA	3830	3832	3836	3140	3144
Fuses recommended for UL applications	[A]	100	125	160	200	200
	3NE	1021-0	1022-0	1224-0	1225-0	1227-0
Input Cable Min.	[mm ²]	25,0	25,0	35,0	70,0	70,0
	[AWG]	3	3	2	2/0	2/0
Input Cable Max.	[mm ²]	35,0	35,0	150,0	150,0	150,0
	[AWG]	2	2	300	300	300
Output Cable Min.	[mm ²]	25,0	25,0	50,0	70,0	95,0
	[AWG]	3	3	1/0	2/0	4/0
Output Cable Max.	[mm ²]	35,0	35,0	150,0	150,0	150,0
	[AWG]	2	2	300	300	300
Frame Size		E			F	
Weight	[kg]	22,0	22,0	75,0	75,0	75,0
	[lbs]	48,0	48,0	165,0	165,0	165,0

1) Secondary conditions: Input current at the rated operating point - applies for the short-circuit voltage of the line supply $V_k = 2\%$ referred to the rated drive converter power and a rated line supply voltage of 400 V without line commutating reactor.

* UL listed fuses such as Class NON from Bussmann are required for use in America

**Input voltage range
(Unfiltered)****3 AC 380 V ... 480 V, ± 10 %**

Order No.	6SE6430-	2UD27-5CA0	2UD31-1CA0	2UD31-5CA0	2UD31-8DA0	2UD32-2DA0	2UD33-0DA0
VT Motor Output Rating	[kW]	7,5	11,0	15,0	18,5	22,0	30,0
	[hp]	10,0	15,0	20,0	25,0	30,0	40,0
Output Power	[kVA]	10,1	14,0	19,8	24,4	29,0	34,3
VT Input Current 1)	[A]	17,3	23,1	33,8	37,0	43,0	59
VT Output Cur. Max.	[A]	19,0	26,0	32,0	38,0	45,0	62,0
Recommended Fuse	[A]	20	32	35	50	63	80
	3NA	3807	3812	3814	3820	3822	3824
Fuses recommended for UL applications	[A]				50	63	80
	3NE	*	*	*	1817-0	1818-0	1820-0
Input Cable Min.	[mm ²]	2,5	4,0	6,0	10,0	10,0	16,0
	[AWG]	14	12	10	8	8	6
Input Cable Max.	[mm ²]	10,0	10,0	10,0	35,0	35,0	35,0
	[AWG]	8	8	8	2	2	2
Output Cable Min.	[mm ²]	2,5	4,0	6,0	10,0	10,0	16,0
	[AWG]	14	12	10	8	8	6
Output Cable Max.	[mm ²]	10,0	10,0	10,0	35,0	35,0	35,0
	[AWG]	8	8	8	2	2	2
Frame Size		C			D		
Weight	[kg]	5,5	5,5	5,5	16,0	16,0	16,0
	[lbs]	12,1	12,1	12,1	35,0	35,0	35,0

Order No.	6SE6430-	2UD33-7EA0	2UD34-5EA0	2UD35-5FA0	2UD37-5FA0	2UD38-8FA0
VT Motor Output Rating	[kW]	37,0	45,0	55,0	75,0	90,0
	[hp]	50,0	60,0	75,0	100,0	120,0
Output Power	[kVA]	47,3	57,2	68,6	83,8	110,5
VT Input Current 1)	[A]	72	87	104	139	169
VT Output Cur. Max.	[A]	75,0	90,0	110,0	145,0	178,0
Recommended Fuse	[A]	100	125	160	160	200
	3NA	3830	3832	3836	3140	3144
Fuses recommended for UL applications	[A]	100	125	160	200	200
	3NE	1021-0	1022-0	1224-0	1225-0	1227-0
Input Cable Min.	[mm ²]	25,0	25,0	35,0	70,0	70,0
	[AWG]	3	3	2	2/0	2/0
Input Cable Max.	[mm ²]	35,0	35,0	150,0	150,0	150,0
	[AWG]	2	2	300	300	300
Output Cable Min.	[mm ²]	25,0	25,0	35,0	70,0	95,0
	[AWG]	3	3	2	2/0	4/0
Output Cable Max.	[mm ²]	35,0	35,0	150,0	150,0	150,0
	[AWG]	2	2	300	300	300
Frame Size		E			F	
Weight	[kg]	20,0	20,0	56,0	56,0	56,0
	[lbs]	44,0	44,0	123,0	123,0	123,0

- 1) Secondary conditions: Input current at the rated operating point - applies for the short-circuit voltage of the line supply $V_k = 2\%$ referred to the rated drive converter power and a rated line supply voltage of 400 V without line commutating reactor.

* UL listed fuses such as Class NON from Bussmann are required for use in America

**Input voltage range
(Unfiltered)**
3 AC 380 V ... 480 V, ± 10 %

Order No.	6SE6430-	2UD41-1FA0	2UD41-3FA0	2UD41-6GA0	2UD42-0GA0	2UD42-5GA0
VT Motor Output Rating	[kW]	110	132	160	200	250
	[hp]	150	200	250	300	333
Output Power	[kVA]	145,4	180	214,8	263,2	339,4
VT Input Current 1)	[A]	200	245	297	354	442
VT Output Cur. Max.	[A]	205	250	302	370	477
Recommended Fuse	[A]	250	315	400	450	560
		3NE1227-0	3NE1230-0	3NE1332-0	3NE1333-0	3NE1435-0
Input Cable Min.	[mm ²]	1 x 95 or 2 x 35	1 x 150 or 2 x 50	1 x 185 or 2 x 70	1 x 240 or 2 x 70	2 x 95
	[AWG] or [kcmil]	1 x 4/0 or 2 x 2	1 x 300 or 2 x 1/0	1 x 400 or 2 x 2/0	1 x 500 or 2 x 2/0	2 x 4/0
Input Cable Max.	[mm ²]	1 x 185 or 2 x 120	1 x 185 or 2 x 120	2 x 240	2 x 240	2 x 240
	[AWG] or [kcmil]	1 x 350 or 2 x 4/0	1 x 350 or 2 x 4/0	2 x 400	2 x 400	2 x 400
Output Cable Min.	[mm ²]	1 x 95 or 2 x 35	1 x 150 or 2 x 50	1 x 185 or 2 x 70	1 x 240 or 2 x 70	2 x 95
	[AWG] or [kcmil]	1 x 4/0 or 2 x 2	1 x 300 or 2 x 1/0	1 x 400 or 2 x 2/0	1 x 500 or 2 x 2/0	2 x 4/0
Output Cable Max.	[mm ²]	1 x 185 or 2 x 120	1 x 185 or 2 x 120	2 x 240	2 x 240	2 x 240
	[AWG] or [kcmil]	1 x 350 or 2 x 4/0	1 x 350 or 2 x 4/0	2 x 400	2 x 400	2 x 400
Pipe cable shoe to DIN 46235	[mm]	10	10	10	10	10
Frame Size		FX		GX		
Weight	[kg]	110	116	170	174	176
	[lbs]	242	256	375	384	388

- 1) Secondary conditions: Input current at the rated operating point - applies for the short-circuit voltage of the line supply $V_k \geq 2.33\%$ referred to the rated drive converter power and a rated line supply voltage of 400 V.

8 Options

An overview of the options available for the MICROMASTER 430 is given in this section. For further information about options, please refer to the catalog or the documentation CD.

8.1 Device-independent options

- Basic Operator Panel 2 (BOP-2)
- PROFIBUS module
- PC to inverter connection kit
- BOP/AOP door mounting kit for single inverter control
- "DriveMonitor" and "Starter" commissioning tool

8.2 Device-dependent options

Frame Sizes C to F

- Gland plate (Frame size C)
- EMC filter, Class A
- EMC filter, Class B (Frame size C)
- Line commutating choke
- Output choke
- LC Filter

CAUTION

If using output chokes or LC filters operation is only permissible with a pulse frequency of **4 kHz**. Make shure that the automatic pulse frequency reductions are disabled.

Coercing required parameter adjusting: P1800 = 4 kHz , P0290 = 0 or 1.

Frame Sizes FX and GX

- Line commutating choke
- EMC filter, Class A (power commutating choke required)
- LC Filter

CAUTION

If using output chokes or LC filters operation is only permissible with a pulse frequency of **4 kHz**. Make shure that the automatic pulse frequency reductions are disabled.

Coercing required parameter adjusting: P1800 = 4 kHz , P0290 = 0 or 1.

9 Electro-magnetic compatibility (EMC)

This Chapter contains:

EMC information.

9.1	Electro-magnetic compatibility	90
-----	--------------------------------------	----

9.1 Electro-magnetic compatibility

(EMC) All manufacturers / assemblers of electrical apparatus which “performs a complete intrinsic function and is placed on the market as a single unit intended for the end user” must comply with the EMC directive 89/336/EEC.

There are three routes for the manufacturer/assembler to demonstrate compliance:

9.1.1 Self-certification

This is a manufacturer's declaration that the European standards applicable to the electrical environment for which the apparatus is intended have been met. Only standards that have been officially published in the Official Journal of the European Community can be cited in the manufacturer's declaration.

9.1.2 Technical construction file

A technical construction file can be prepared for the apparatus describing its EMC characteristics. This file must be approved by a ‘Competent Body’ appointed by the appropriate European government organization. This approach allows the use of standards that are still in preparation.

9.1.3 EC type examination certificate

This approach is only applicable to radio communication transmitting apparatus. All MICROMASTER 430 units are certified for compliance with the EMC directive, when installed in accordance with the recommendations in Section 2.

9.1.4 EMC Directive Compliance with Imminent Harmonics Regulations

Since 1st January 2001 all electrical apparatus covered by the EMC Directive will have to comply with EN 61000-3-2 "Limits for harmonic current emissions (equipment input ≤ 16 A per phase)".

All Siemens variable speed drives of the MICROMASTER, MIDIMASTER, MICROMASTER Eco and COMBIMASTER ranges, which are classified as "Professional Equipment" within the terms of the standard, fulfill the requirements of the standard.

The allowed harmonic currents for “professional equipment” with an input power > 1 kW are not yet defined. Therefore, any electrical apparatus containing the above drives which has an input power > 1 kW will not require connection approval.

9.1.5 Classification of EMC performance

Three General classes of EMC performance are available as detailed below:

Class 1: General Industrial

Compliance with European Standard EN 61800-3 (EMC Product Standard for Power Drive Systems) for use in **Second Environment (Industrial)**.

Table 9-1 General Industrial

EMC Phenomenon		Standard	Level
Emissions:	Radiated Emissions	EN 55011	Level A1
	Leitungsgebundene Emissionen	EN 61800-3	Limits complying with EN 55011, Class A, Group 2
Immunity:	Electrostatic Discharge	EN 61000-4-2	8 kV air discharge
	Burst Interference	EN 61000-4-4	2 kV power cables, 1 kV control
	Radio Frequency Electromagnetic Field	EN 61000-4-3	26-1000 MHz, 10 V/m

Class 2: Filtered Industrial

This level of performance will allow the manufacturer/assembler to self-certify their apparatus for compliance with the EMC directive for the industrial environment as regards the EMC performance characteristics of the power drive system. Performance limits are as specified in the Generic Industrial Emissions and Immunity standards EN 50081-2 and EN 50082-2.

Table 9-2 Filtered Industrial

EMC Phenomenon		Standard	Level
Emissions:	Radiated Emissions	EN 55011	Limit A1
	Conducted Emissions	EN 61800-3	Limits complying with EN 55011, Class A, Group 2
Immunity:	Supply Voltage Distortion	EN 61000-2-4	
	Voltage Fluctuations, Dips, Unbalance, Frequency Variations	EN 61000-2-1	
	Magnetic Fields	EN 61000-4-8	50 Hz, 30 A/m
	Electrostatic Discharge	EN 61000-4-2	8 kV air discharge
	Burst Interference	EN 61000-4-4	2 kV power cables, 2 kV control
	Radio Frequency Electromagnetic Field, amplitude modulated	EN 61000-4-3	80-1000 MHz, 10 V/m, 80% AM, power and signal lines
	Radio-frequency Electromagnetic Field, pulse modulated	EN 61000-4-3	900 MHz, 10 V/m 50% duty cycle, 200 Hz repetition rate

Only Frame Size C

Class 3: Filtered - for residential, commercial and trade applications

This level of performance will allow the manufacturer / assembler to self-certify compliance of their apparatus with the EMC directive for the residential, commercial and trade applications environment as regards the EMC performance characteristics of the power drive system. Performance limits are as specified in the generic emission and immunity standards EN 61000-6-3 and EN 61000-6-1 in residential.

Table 9-3 Filtered for Residential, Commercial and trade applications

EMC Phenomenon		Standard	Level
Emissions:	Radiated Emissions*	EN 55011	Limit B
	Conducted Emissions	EN 61800-3	Category C1: Limit complying with EN 55011, Class B Category C2: Limit complying with EN 55011, Class A
Immunity:	Supply Voltage Distortion	EN 61000-2-4	
	Voltage Fluctuations, Dips, Unbalance, Frequency Variations	EN 61000-2-1	
	Magnetic Fields	EN 61000-4-8	50 Hz, 30 A/m
	Electrostatic Discharge	EN 61000-4-2	8 kV air discharge
	Burst Interference	EN 61000-4-4	2 kV power cables, 2 kV control
	Radio Frequency Electromagnetic Field, amplitude modulated	EN 61000-4-3	80-1000 MHz, 10 V/m, 80% AM, power and signal lines
	Radio-frequency Electromagnetic Field, pulse modulated	EN 61000-4-3	900 MHz, 10 V/m 50% duty cycle, 200 Hz repetition rate

* These limits are dependent on the inverter being correctly installed inside a metallic switchgear enclosure. The limits will not be met if the inverter is not enclosed.

Notes

- To achieve these performance levels, you must not exceed the default Pulse frequency nor use cables longer than 25 m.
- The MICROMASTER inverters are intended **exclusively for professional applications**. Therefore, they do not fall within the scope of the harmonics emissions specification EN 61000-3-2.
- Maximum mains supply voltage when filters are fitted is 480 V.

Table 9-4 Compliance Table

Frame Sizes C to F

Class 1 – General Industrial	
6SE6430-2U***-**A0	Units without filters, all voltages and performances. The product norm EN 61800-3 +A11 for "Variable-speed electrical drives, Part 3: EMC product standard including specific test methods" specifies limits for conducted emissions which cannot be complied with by unfiltered inverters in the second environment. Filtered inverters (as described under Class 2) must be installed for drive systems in C3 installations. The use of unfiltered inverters in industrial environments is allowed only if they are part of a system which is equipped with line filters on the higher-level supply side.
Class 2 – Filtered Industrial	
6SE6430-2A***-**A0	All units with integral Class A filters
Class 3 – Filtered for residential, commercial and trade applications	
6SE6430-2A***-**A0 with 6SE6400-2FS0*-*0	Units with fitted Class A filters and additional external Class B filters.
6SE6430-2U***-**A0 with EMV-Filter Class B (e.g. Fa. Schaffner) 6SE6430-2A***-**A0	Unfiltered units fitted with external Class B filters All units with fitted Class A filters. For drive systems in category C2 installations, the following warning notice is necessary: In residential environments, this product may cause radio-frequency disturbances which may necessitate interference suppression measures.
* denotes any value is allowed.	

Frame Sizes FX to GX

Class 1 – General Industrial	
6SE6430-2U***-**A0	Units without filters, all voltages and performances. The product norm EN 61800-3 +A11 for "Variable-speed electrical drives, Part 3: EMC product standard including specific test methods" specifies limits for conducted emissions which cannot be complied with by unfiltered inverters in the second environment. Filtered inverters (as described under Class 2) must be installed for drive systems in C3 installations. The use of unfiltered inverters in industrial environments is allowed only if they are part of a system which is equipped with line filters on the higher-level supply side.
Class 2 – Filtered Industrial	
6SE6430-2U***-**A0 with 6SL3000-0BE***0	With external EMI filter (available as an option) the limiting values of the EN 55011, Class A are fulfilled for conducted emission. (line commutating choke required)
* denotes any value is allowed.	

- Category C3: Drive system (PDS) with rated voltage < 1000 V.
For use in second environment.
- Category C2: Drive system (PDS) with rated voltage < 1000 V. For use in first environment. Installation and commissioning by EMC expert only.
- Category C1: Drive system (PDS) with rated voltage < 1000 V.
For use in first environment.

Appendices

A Changing the Operator Panel

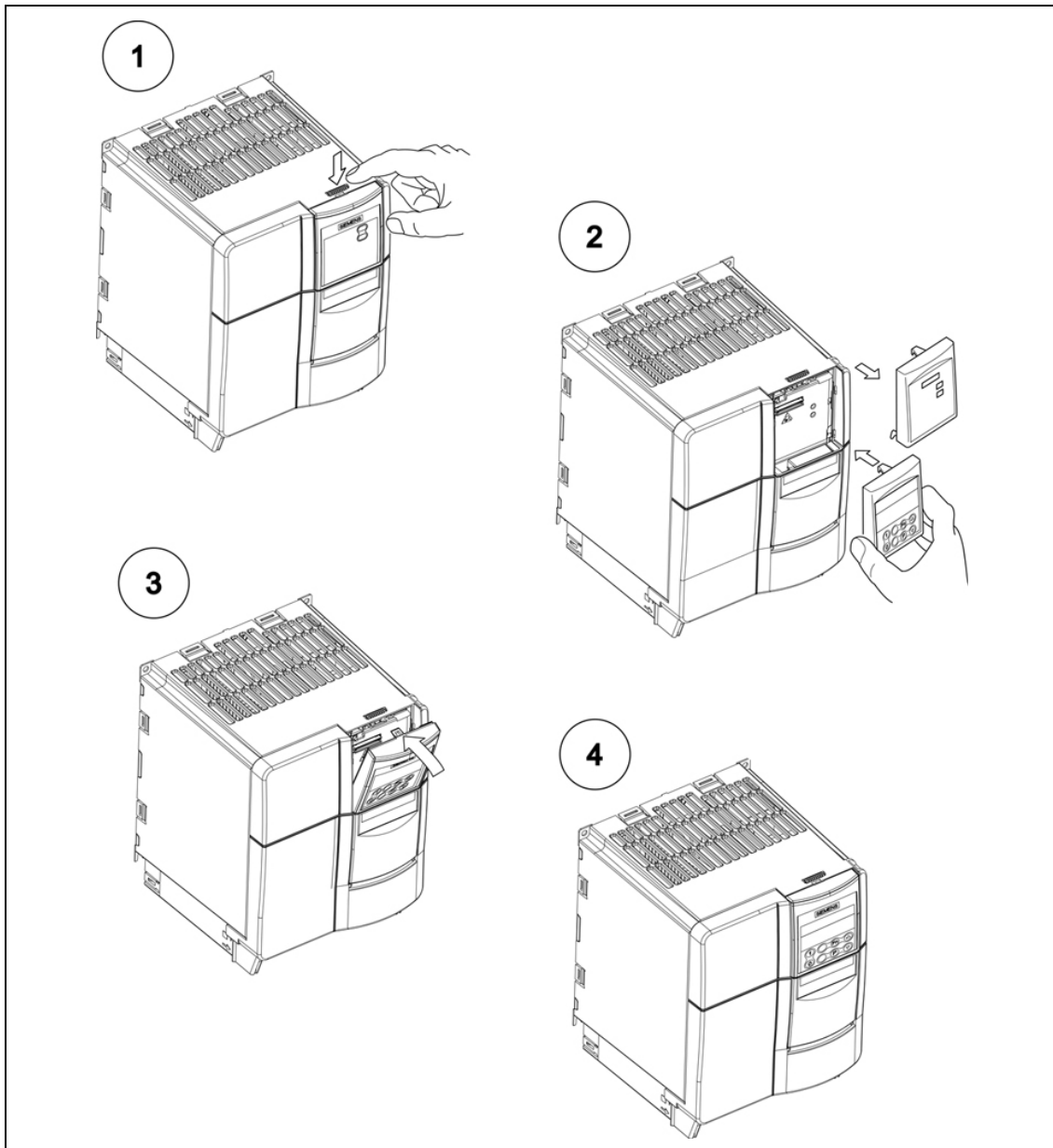

B Removing Front Covers

B.1 Removing Front Covers Frame Size C

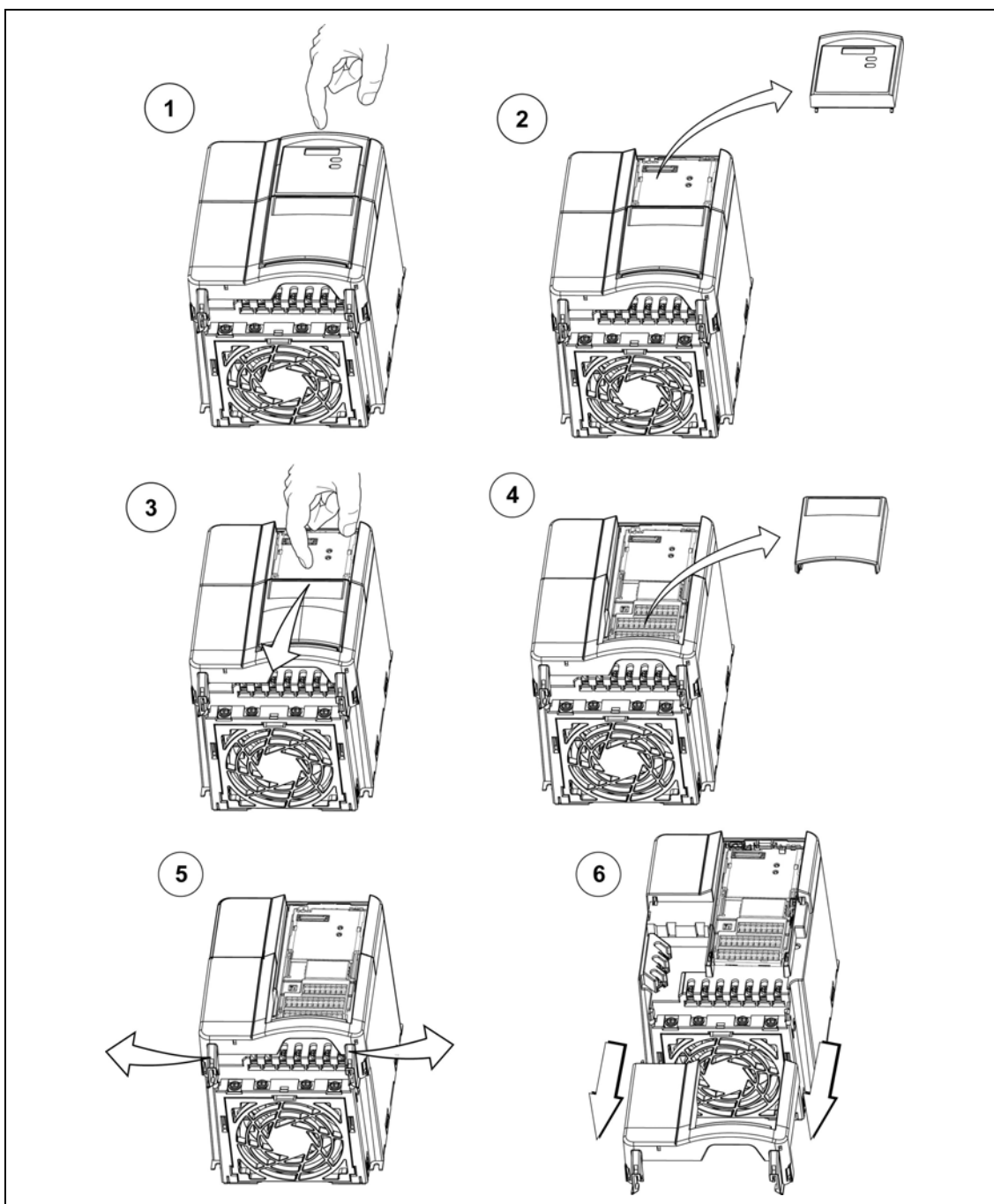

B.2 Removing Front Covers Frame Sizes D and E

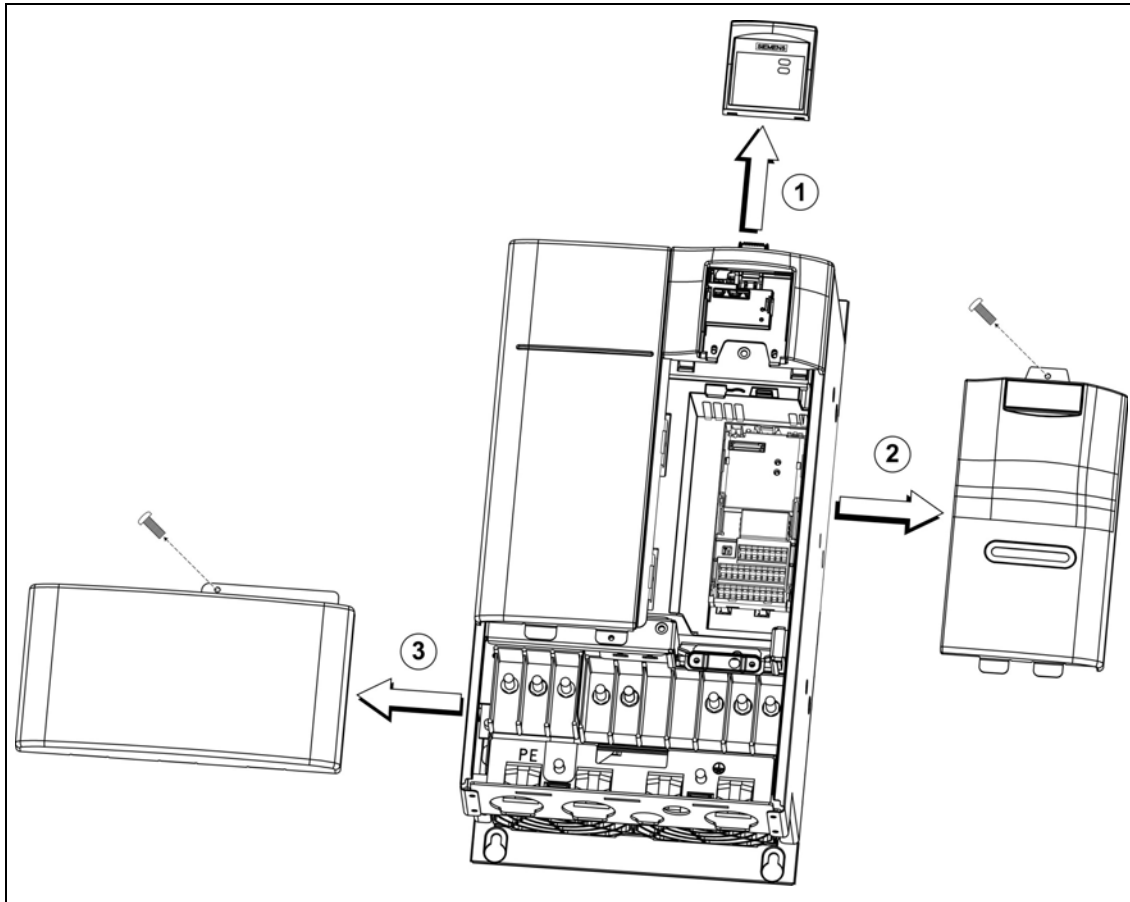

B.3 Removing Covers Frame Size F

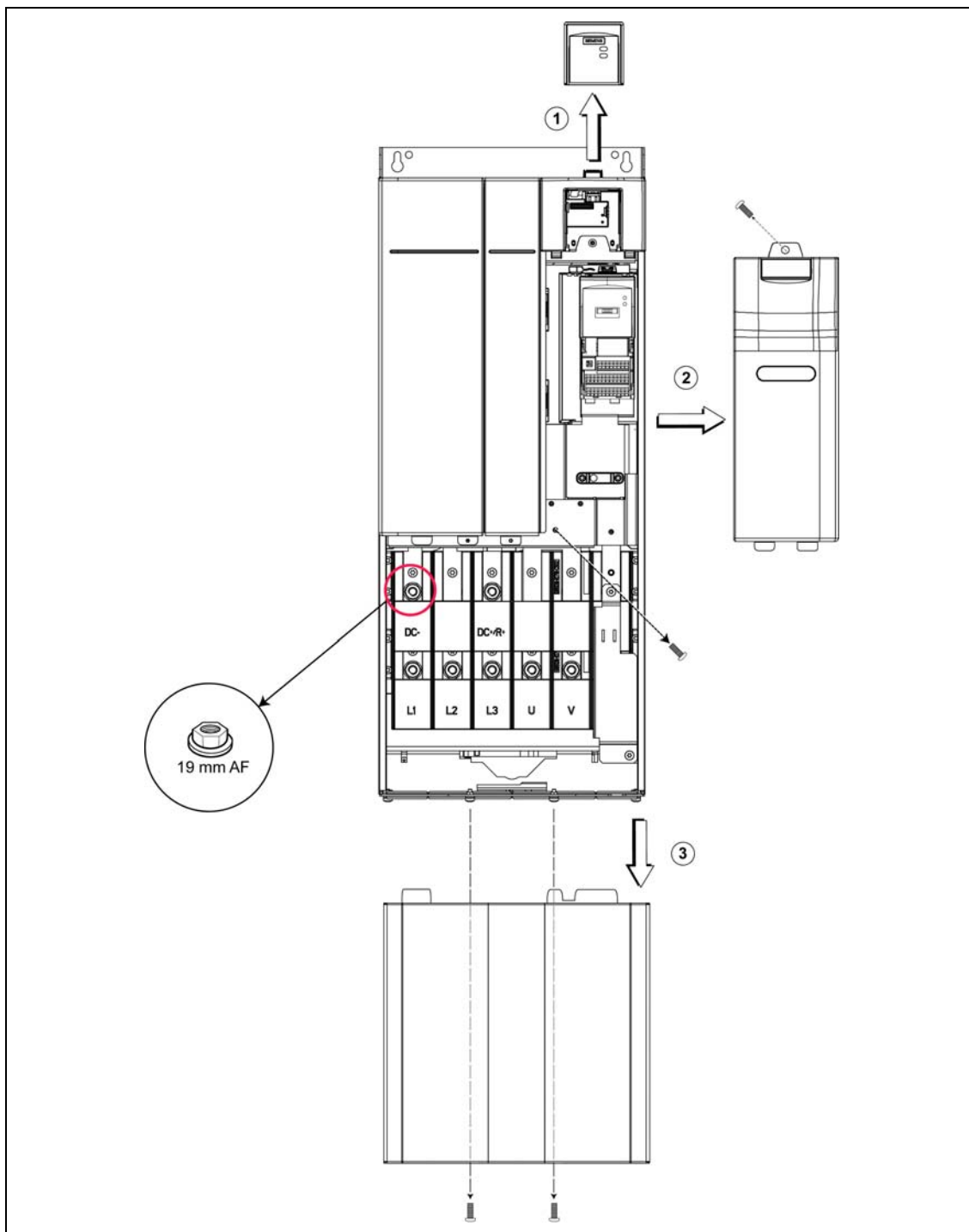

B.4 Removing Front Covers Frame Sizes FX and GX

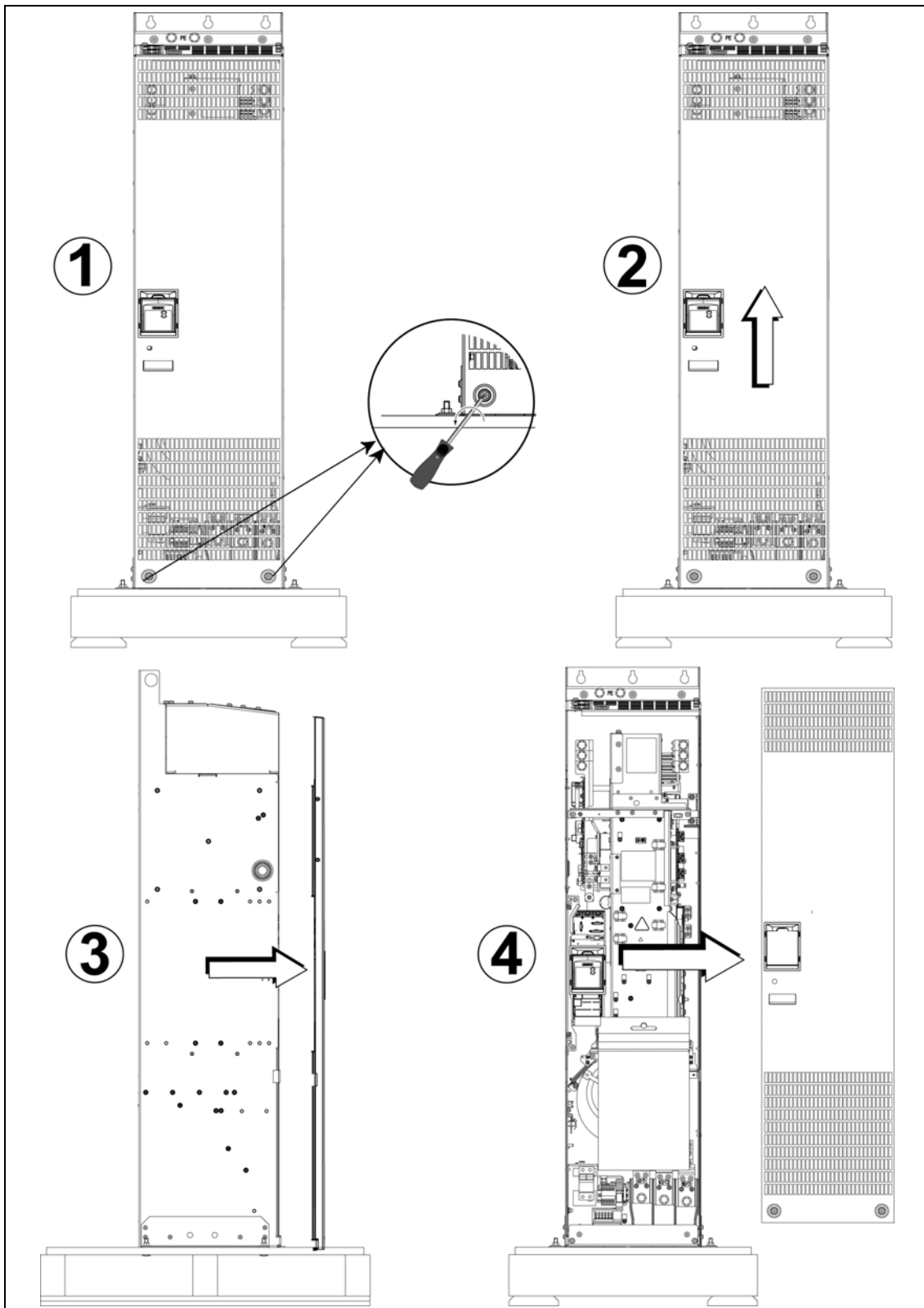

C Removing the I/O Board

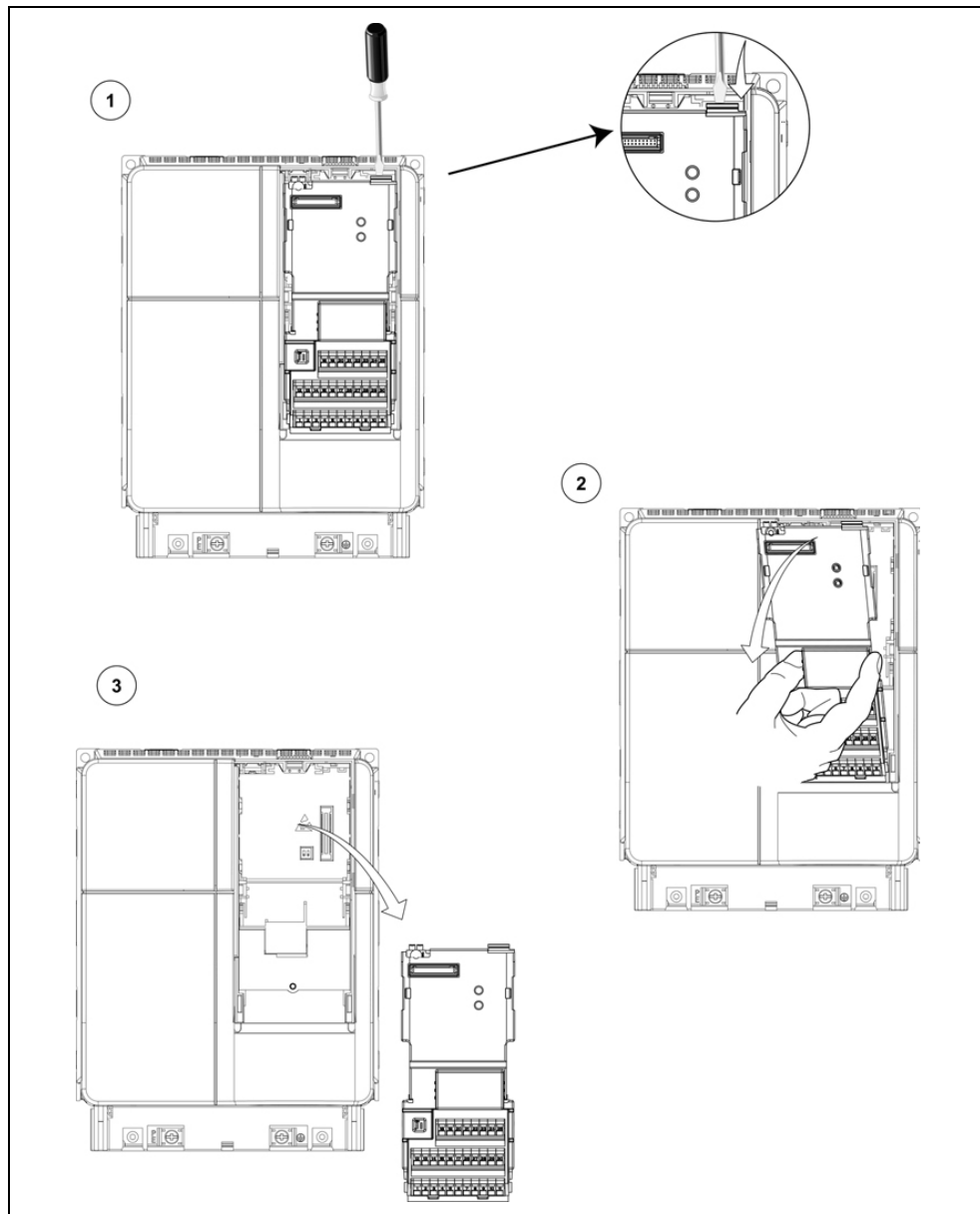

NOTICE

1. Only a small amount of pressure is required to release the I/O Board catch.
2. the I/O Board is removed using the same technique regardless of frame size.

D Removing 'Y' Cap

D.1 Removing 'Y' Cap Frame Size C

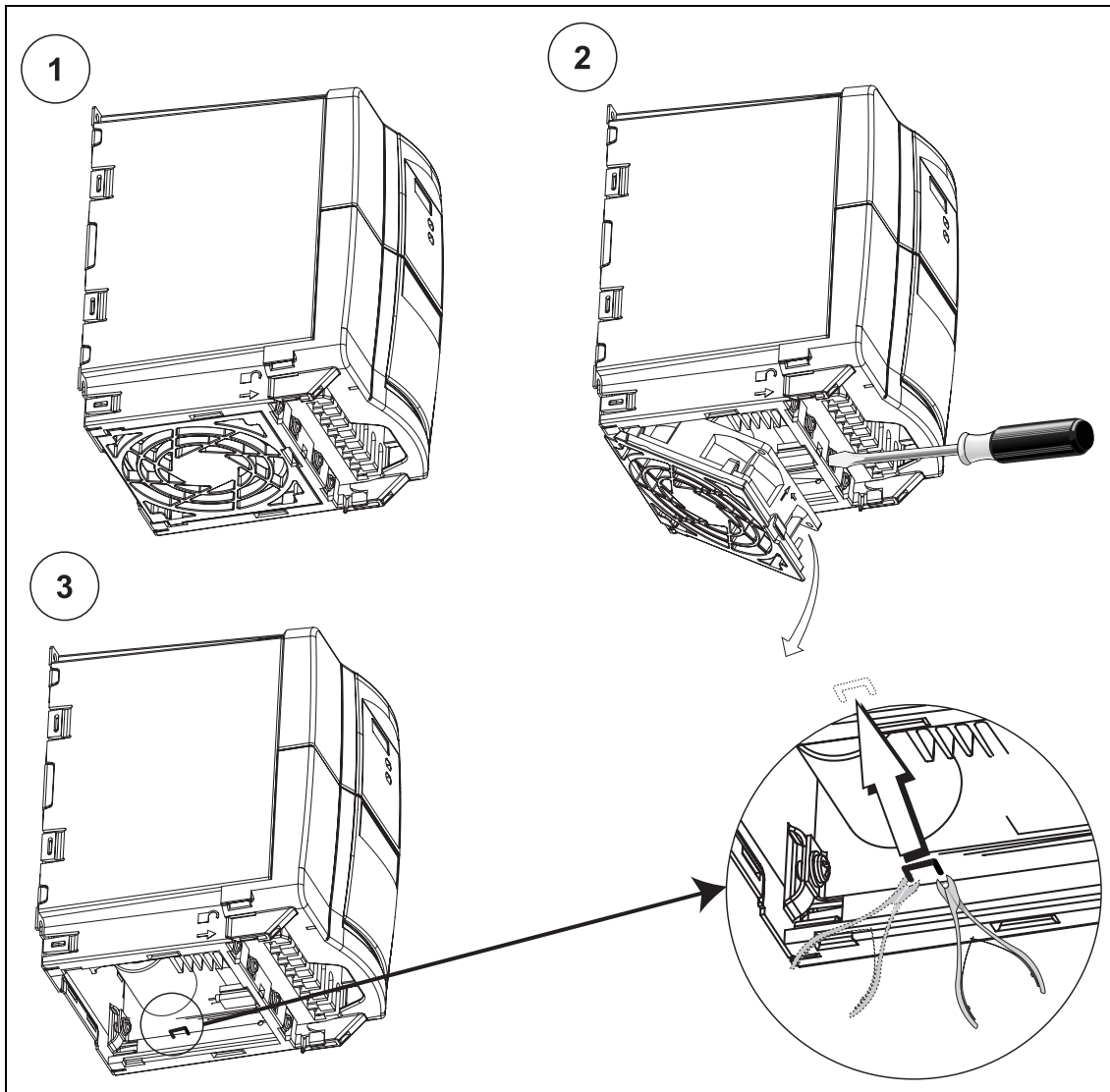

D.2 Removing 'Y' Cap Frame Sizes D and E

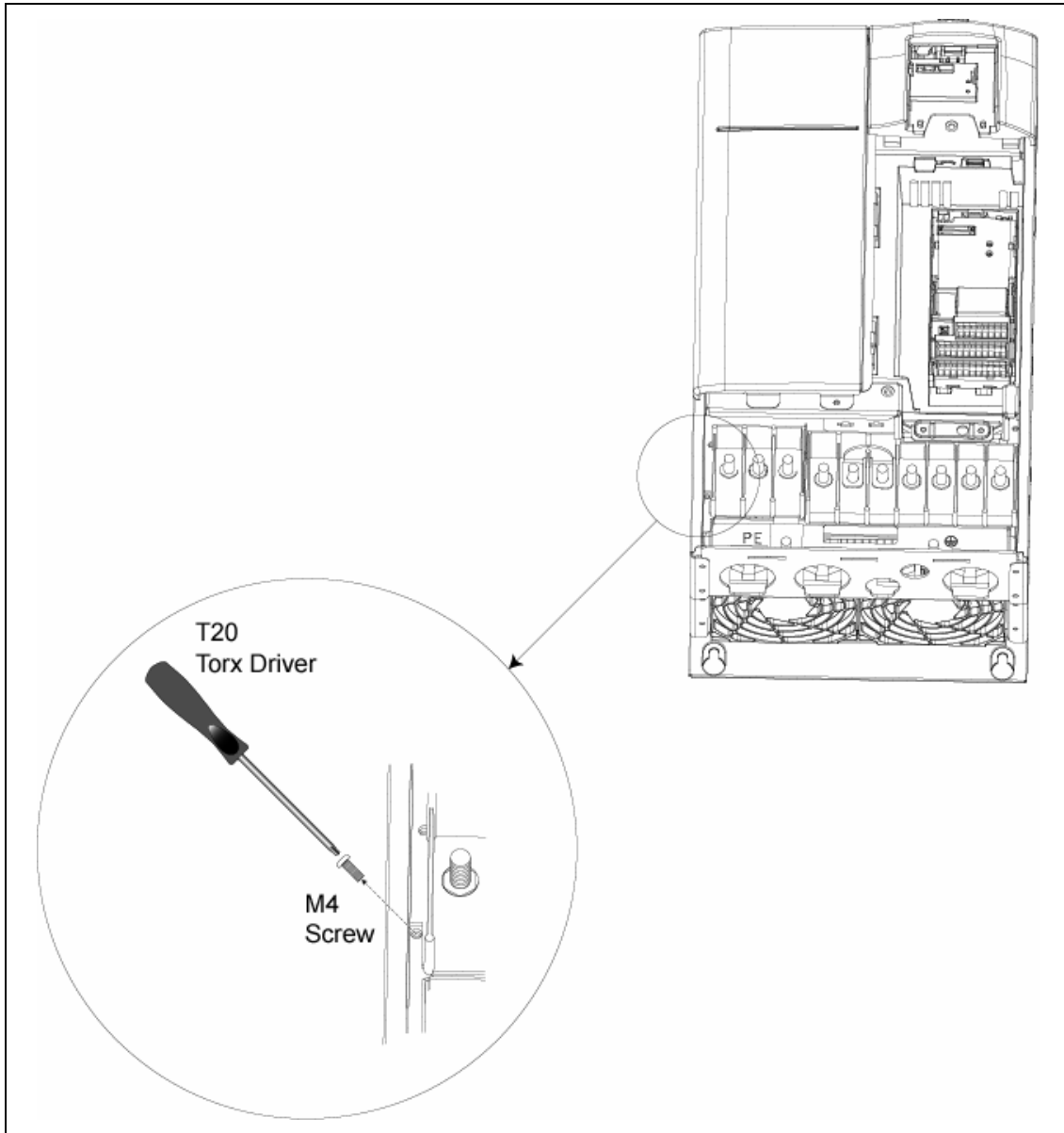

D.3 Removing 'Y' Cap Frame Sizes F

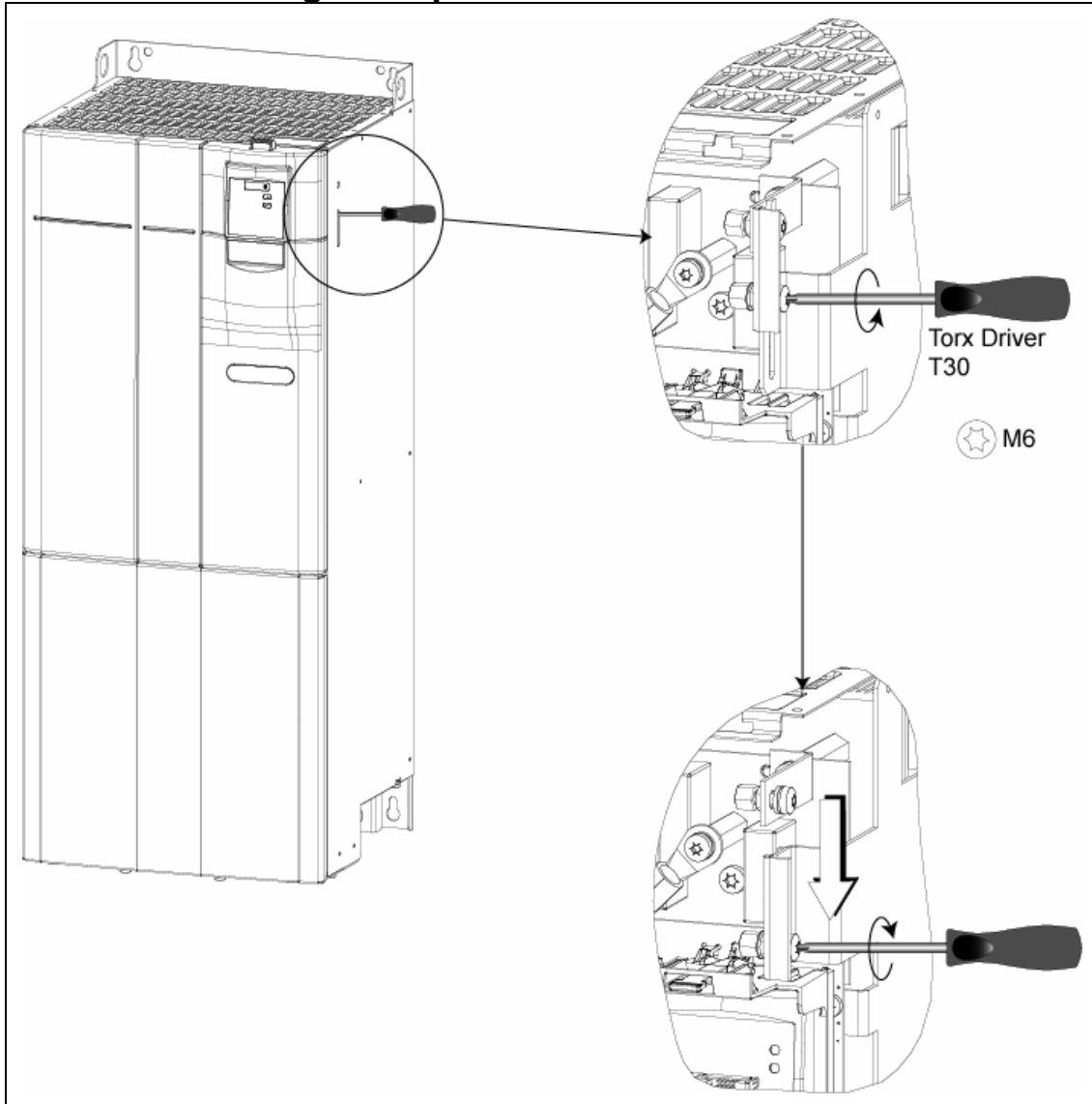

D.4 Removing 'Y' Cap Frame Sizes FX

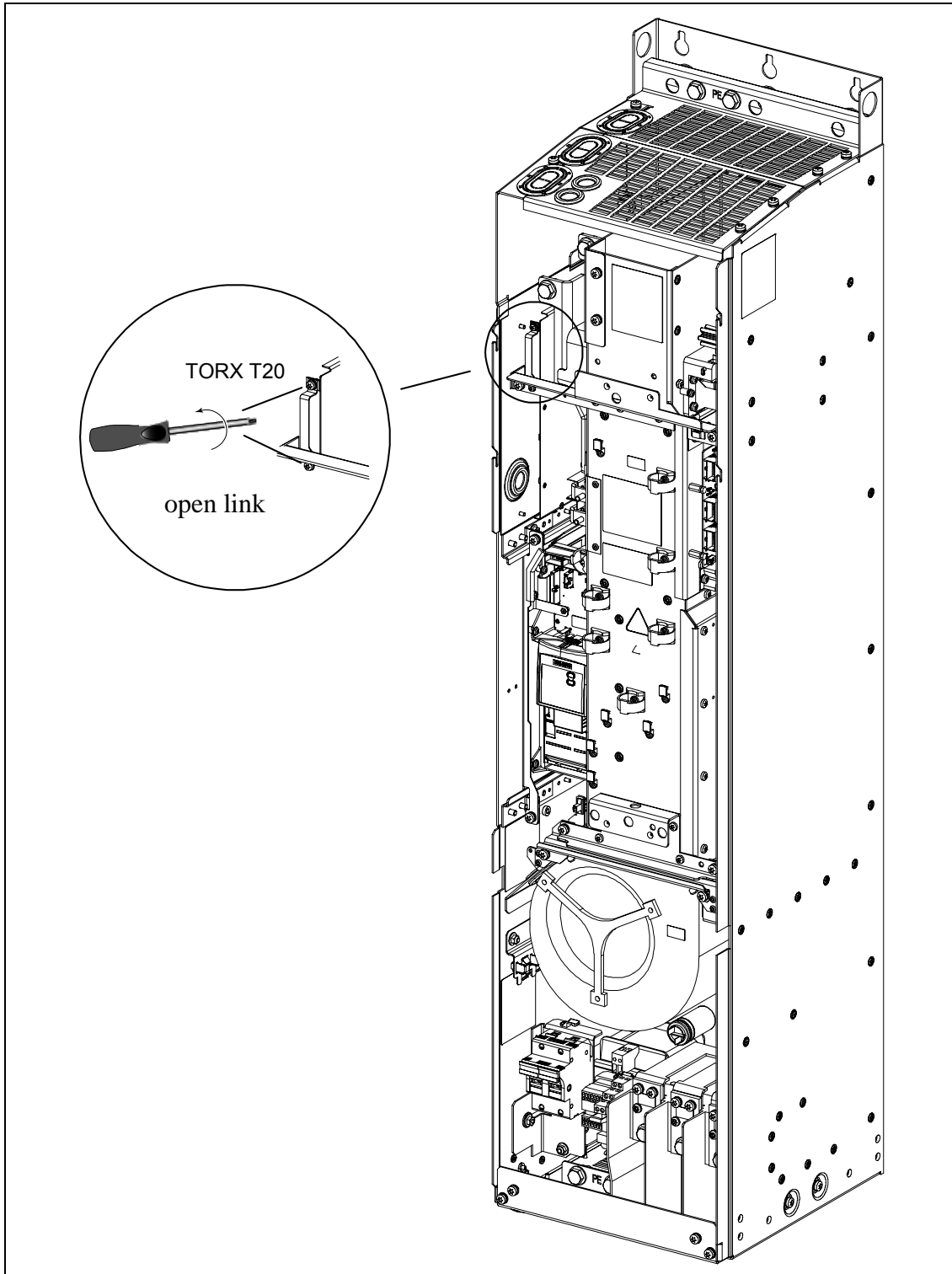

D.5 Removing 'Y' Cap Frame Sizes GX

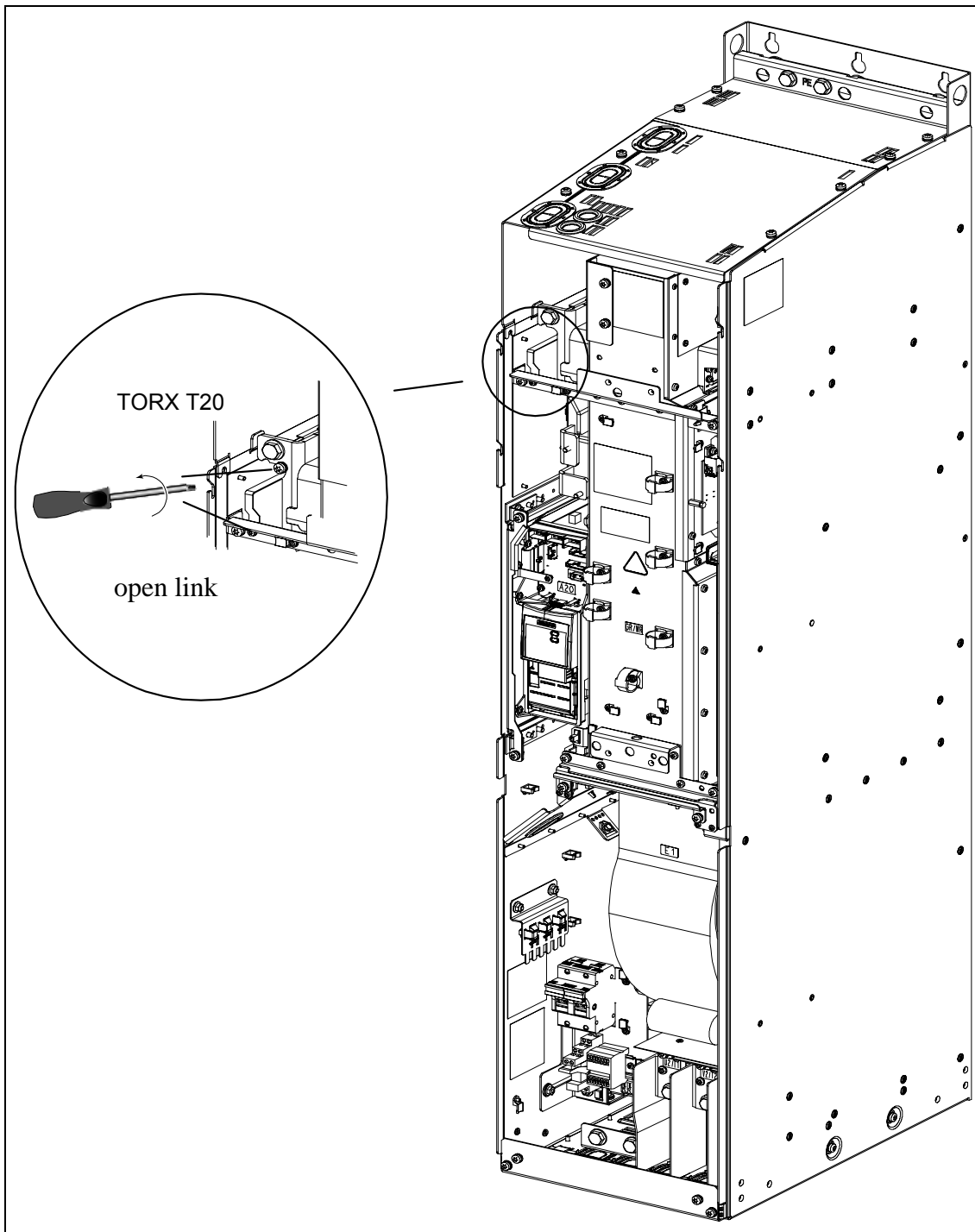

E Applicable Standards



European Low Voltage Directive

The MICROMASTER product range complies with the requirements of the Low Voltage Directive 73/23/EEC as amended by Directive 98/68/EEC. The units are certified for compliance with the following standards:

EN 61800-5-1 Adjustable speed electrical power drive systems,
Part 5-1: Safety requirements –
Electrical, thermal and energy

EN 60204-1 Safety of machinery - Electrical equipment of machines

European Machinery Directive

The MICROMASTER inverter series does not fall under the scope of the Machinery Directive. However, the products have been fully evaluated for compliance with the essential Health & Safety requirements of the directive when used in a typical machine application. A Declaration of Incorporation is available on request.

European EMC Directive

When installed according to the recommendations described in this manual, the MICROMASTER fulfils all requirements of the EMC Directive as defined by the EMC Product Standard for Power Drive Systems EN 61800-3.



Underwriters Laboratories

UL and CUL LISTED POWER CONVERSION EQUIPMENT.

ISO 9001

Siemens plc operates a quality management system, which complies with the requirements of ISO 9001.

F Short circuit current rating (SCCR)

Frame Size C

The equipment has a "standard SCCR" value of 10 kA, which complies with the requirements of UL508C.

In addition to the "standard SCCR" a "high SCCR" is available which can be used for industrial control panel installations in line with the National Electrical Code (NEC) article 409 (edition 2005) and Underwriters Laboratories UL508A (effective April 2006).

The UL certification of MICROMASTER 430 allows the drives to adopt a high SCCR equal to the interrupt current rating of the branch-circuit protection (BCP) device protecting the drive.

Hence by selection of the correct UL listed BCP device with appropriate interrupt rating for the application, any high SCCR rating can be achieved for MICROMASTER 430, including SCCR values above 10 kA.

The above statements are valid for the respective maximum voltage of the drive when protected by a UL recognised/listed H, J or K type fuse, a circuit breaker or self-protected combination motor controller.

Frame Sizes D to GX

The equipment has a "standard SCCR" value of 42 kA, which complies with the requirements of UL508C.

A "high SCCR", which can be used for industrial control panel installations in line with the National Electrical Code (NEC) article 409 (edition 2005) and Underwriters Laboratories UL508A (effective April 2006), can be achieved with the use of current limiting fuses or circuit breakers with an appropriate interrupt rating and derived let through current.

For compliance with NEC article 409 and UL508A the calculation, selection and marking of the current limiting device must be carried out by a qualified engineer.

The above statements are valid for the respective maximum voltage of the drive when protected by a UL recognised/listed H, J or K type fuse, a circuit breaker or self-protected combination motor controller.

G List of Abbreviations

AC	Alternating current
AD	Analog digital converter
ADC	Analog digital converter
ADR	Address
AFM	Additional frequency modification
AIN	Analog input
AOP	Advanced operator panel
AOUT	Analog output
ASP	Analog setpoint
ASVM	Asymmetric space vector modulation
BCC	Block check character
BCD	Binary-coded decimal code
BI	Binector input
BICO	Binector / connector
BO	Binector output
BOP	Basic operator panel
C	Commissioning
CB	Communication board
CCW	Counter-clockwise
CDS	Command data set
CFM	Cubic feet per minute (1 l/s \cong 2,1 CFM)
CI	Connector input
CM	Configuration management
CMD	Commando
CMM	Combimaster
CO	Connector output
CO/BO	Connector output / Binector output
COM	Common (terminal that is connected to NO or NC)
COM-Link	Communication link
CT	Commissioning, ready to run
CT	Constant torque
CUT	Commissioning, run, ready to run
CW	Clockwise
DA	Digital analog converter
DAC	Digital analog converter
DC	Direct current
DDS	Drive data set
DIN	Digital input

DIP	DIP switch
DOUT	Digital output
DS	Drive state
EEC	European Economic Community
EEPROM	Electrical erasable programmable read-only
ELCB	Earth leakage circuit breaker
EMC	Electro-magnetic compatibility
EMF	Electromotive force
EMI	Electro-magnetic interference
FAQ	Frequently asked questions
FCC	Flux current control
FCL	Fast current limit
FF	Fixed frequency
FFB	Free function block
FOC	Field orientated control
FSA	Frame size A
GSG	Getting started guide
GUI ID	Global unique identifier
HIW	Main actual value
HSW	Main setpoint
HTL	High-threshold logic
I/O	Input and output
IBN	Commissioning
IGBT	Insulated gate bipolar transistor
IND	Sub-index
JOG	Jog
KIB	Kinetic buffering
KTY	
LCD	Liquid crystal display
LED	Light emitting diode
LGE	Length
MHB	Motor holding brake
MM4	MICROMASTER 4th. Generation
MOP	Motor potentiometer
NC	Normally closed
NO	Normally open
NPN	
OPI	Operating instructions
PDS	Power drive system
PID	PID controller (proportional, integral, derivative)
PKE	Parameter ID
PKW	Parameter ID value
PLC	Programmable logic controller
PLI	Parameter list

PNP	
PPO	Parameter process data object
PTC	Positive temperature coefficient
PWE	Parameter value
PWM	Pulse-width modulation
PX	Power extension
PZD	Process data
QC	Quick commissioning
RAM	Random-access memory
RCCB	Residual current circuit breaker
RCD	Residual current device
RFG	Ramp function generator
RFI	Radio-frequency interference
RPM	Revolutions per minute
SCL	Scaling
SDP	Status display panel
SLVC	Sensorless vector control
STW	Control word
STX	Start of text
SVM	Space vector modulation
TTL	Transistor-transistor logic
USS	Universal serial interface
VC	Vector control
VT	Variable torque
ZSW	Status word

Index

A

Access Levels.....	68
Adaptation of fan voltage.....	35
Altitude.....	20
Ambient operating conditions	
Altitude.....	20
Atmospheric Pollution.....	21
Electromagnetic Radiation.....	21
Humidity Range.....	20
Installation und Kühlung.....	21
Shock.....	20
Vibration.....	20
Water hazard.....	21
Ambient operating conditions.....	20
Applicable standards	
European EMC Directive.....	102
European Low Voltage Directive.....	102
European Machinery Directive.....	102
ISO 9001.....	102
Underwriters Laboratories.....	102
Atmospheric pollution.....	21

B

Basic operation	
changing parameters with BOP-2.....	49
external motor thermal overload protection.....	53, 55
general.....	54
with BOP-2.....	54
with SDP.....	45
Belt Failure Detection.....	63
BOP-2	
default settings with BOP-2.....	47
operation with BOP-2.....	47
Bypass Mode.....	62

C

Commissioning.....	39
Compound braking.....	60
connection drawing – frame size FX.....	32
connection drawing – frame size GX.....	33
Connection Terminals.....	31
Contact address.....	5
Control modes.....	61

Current reduction depending on pulse frequency.....	77
---	----

D

DC braking.....	60
Default settings.....	47
Dimensions and Torques.....	26
Drill pattern for MICROMASTER 440.....	23

E

Electrical Installation.....	28
Electro-Magnetic Compatibility	
EC type-examination certificate.....	86
general.....	85, 86
self-certification.....	86
technical construction file.....	86
Electro-Magnetic Interference.....	36
avoiding EMI.....	36
Electromagnetic radiation.....	21
EMC.....	86
EMC Directive Compliance.....	86
EMC performance	
filtered for residential, commercial and light industry.....	89
filtered industrial class.....	88
general industrial class.....	87
EMI.....	36
Energy Saving Mode.....	65

F

Fan fuses.....	35
Fault messages	
with the BOP-2 fitted.....	73
with the SDP fitted.....	72
Faults and Alarms	
with BOP-2.....	66
with SDP.....	66
Features.....	15
flux current control (FCC).....	61
Foreword.....	5
Free Function Blocks.....	66
Frequency set point.....	58

H		
Humidity Range	20	
I		
Installation	17	
after a period of storage.....	17, 19	
Installation dimensions for MICROMASTER 440 Version FX	24	
Installation of options in the electronic box	27	
Installation und Kühlung	21	
Internet Home Address	5	
Inverter block diagram.....	41	
L		
Linear U/f control	61	
Long cables operation with.....	29	
M		
Main characteristics.....	15	
Mechanical Installation	22	
MICROMASTER 430 general	14	
main characteristics	15	
performance characteristics.....	16	
protection characteristics	16	
specifications	75	
Motor connections	30	
Motor data	53	
Motor Staging	64	
Multiple point U/f control.....	61	
O		
Operation OFF and brake function	59	
Operation with long cables.....	29	
Residual Current Device	29	
ungrounded IT supplies	29	
Operator panels BOP-2	47	
changing the operator panel	91	
SDP.....	44	
Options Device-dependent options	83	
Device-independent options	83	
Options for electronic box.....	27	
Overview.....	13	
P		
Parabolic U/f control.....	61	
Parameter Systemparameter	67	
Parameters changing parameters with BOP-2	49	
Performance characteristics	16	
Performance Ratings	76	
Power and motor connections	30	
single phase	34	
Protection characteristics.....	16	
Q		
Qualified personnel.....	6	
Quick commissioning	50	
R		
Removing 'Y' Cap Frame Sizes C	97	
Removing 'Y' Cap Frame Sizes D and E. 98		
Removing 'Y' Cap Frame Sizes F.....	99	
Removing Covers Frame Size C	92	
Removing Covers Frame Size F.....	94	
Removing Covers Frame Sizes D and E.....	93, 95	
Removing the I/O Board	96	
Reset to Factory default.....	53	
Residual Current Device operation with	29	
S		
Safety instructions.....	7	
Screening Methods.....	37	
SDP Default settings.....	44	
operation with SDP.....	44	
Shock	20	
Specifications.....	78	
T		
Technical Support	5	
Terminal Torques.....	77	
Troubleshooting	71	
U		
Ungrounded (IT) supplies operation with	29	

W

Warnings, cautions & notes			
commissioning	8	operation	9
definitions	6	repair	9
dismantling & disposal	9	transport & storage.....	8
general	7	Water hazard	21
		Wiring Guidelines EMI	37

Suggestions and/or Corrections

<p>To: Siemens AG Automation & Drives Group SD SPA PM 4 P.O. Box 3269 D-91050 Erlangen Federal Republic of Germany Email: documentation.sd@siemens.com</p>	<p>Suggestions</p> <hr/> <p>Corrections</p> <p>For Publication/Manual: MICROMASTER 430</p> <p>User Documentation</p>
<p>From</p> <p>Name: _____</p> <p>Company/Service Department _____</p> <p>Address: _____ _____</p> <p>Telephone: _____ / _____</p> <p>Telefax: _____ / _____</p>	<p>Operating Instructions</p> <p>Order Number: 6SE6400-5AE00-0BP0</p> <p>Date of Issue: 10/06</p> <p>Should you come across any printing errors when reading this publication, please notify us on this sheet.</p> <p>Suggestions for improvement are also welcome.</p>

Siemens AG
Bereich Automation and Drives (A&D)
Geschäftsgebiet Standard Drives (SD)
Postfach 3269, D-91050 Erlangen
Federal Republic of Germany

© Siemens AG, 2002, 2005, 2006
Subject to change without prior notice

Siemens Aktiengesellschaft

Order No.: 6SE6400-5AE00-0BP0
Date: 10/06

