

# SINAMICS G120C

Frequency converter

Getting Started · 03/2012



## SINAMICS

Answers for industry.

**SIEMENS**



# SIEMENS

## SINAMICS

### SINAMICS G120C SINAMICS G120C frequency converter

#### Getting Started

<u>Product overview</u>	1
<u>Safety notes</u>	2
<u>Installing</u>	3
<u>Commissioning</u>	4
<u>Trouble shooting</u>	5

Edition 03/2012, Firmware V4.5



03/2012, FW V4.5

A5E03831830B AA

## Legal information

### Warning notice system

This manual contains notices you have to observe in order to ensure your personal safety, as well as to prevent damage to property. The notices referring to your personal safety are highlighted in the manual by a safety alert symbol, notices referring only to property damage have no safety alert symbol. These notices shown below are graded according to the degree of danger.

 <b>DANGER</b>
indicates that death or severe personal injury <b>will</b> result if proper precautions are not taken.
 <b>WARNING</b>
indicates that death or severe personal injury <b>may</b> result if proper precautions are not taken.
 <b>CAUTION</b>
with a safety alert symbol, indicates that minor personal injury can result if proper precautions are not taken.
<b>CAUTION</b>
without a safety alert symbol, indicates that property damage can result if proper precautions are not taken.
<b>NOTICE</b>
indicates that an unintended result or situation can occur if the relevant information is not taken into account.

If more than one degree of danger is present, the warning notice representing the highest degree of danger will be used. A notice warning of injury to persons with a safety alert symbol may also include a warning relating to property damage.

### Qualified Personnel

The product/system described in this documentation may be operated only by **personnel qualified** for the specific task in accordance with the relevant documentation, in particular its warning notices and safety instructions. Qualified personnel are those who, based on their training and experience, are capable of identifying risks and avoiding potential hazards when working with these products/systems.

### Proper use of Siemens products

Note the following:

 <b>WARNING</b>
Siemens products may only be used for the applications described in the catalog and in the relevant technical documentation. If products and components from other manufacturers are used, these must be recommended or approved by Siemens. Proper transport, storage, installation, assembly, commissioning, operation and maintenance are required to ensure that the products operate safely and without any problems. The permissible ambient conditions must be complied with. The information in the relevant documentation must be observed.

### Trademarks

All names identified by ® are registered trademarks of Siemens AG. The remaining trademarks in this publication may be trademarks whose use by third parties for their own purposes could violate the rights of the owner.

### Disclaimer of Liability

We have reviewed the contents of this publication to ensure consistency with the hardware and software described. Since variance cannot be precluded entirely, we cannot guarantee full consistency. However, the information in this publication is reviewed regularly and any necessary corrections are included in subsequent editions.

# Table of contents

<b>1</b>	<b>Product overview</b> .....	<b>4</b>
<b>2</b>	<b>Safety notes</b> .....	<b>5</b>
<b>3</b>	<b>Installing</b> .....	<b>9</b>
3.1	Mechanical installation .....	9
3.2	Electrical installation .....	10
3.3	Pre-defined interface configurations .....	14
3.4	Description files for fieldbus configuration .....	18
<b>4</b>	<b>Commissioning</b> .....	<b>19</b>
4.1	Basic commissioning with BOP-2 .....	22
4.2	Further settings .....	24
4.2.1	Changing the function of terminals .....	25
4.2.2	Releasing "Safe Torque Off" .....	26
4.2.3	Parameter list .....	27
<b>5</b>	<b>Trouble shooting</b> .....	<b>43</b>
5.1	List of alarms and faults .....	43
5.2	Product support.....	49
5.3	Spare parts.....	49

This Getting Started Guide describes how you install and commission the SINAMICS G120C converter.

# 1

## Product overview

The SINAMICS G120C is a range of converters for controlling the speed of three phase motors. The converter is available in three frame sizes.

You find a label with the order number:

- On the front of the converter after removing the blind cover or the operator panel.
- On one side of the converter.



	Rated output power	Rated output current	Order number			
	based on Low Overload		Unfiltered		Filtered	
 <p>Frame Size A</p>	0.55 kW	1.7 A	6SL3210-1KE11-8U	1	6SL3210-1KE11-8A	1
	0.75 kW	2.2 A	6SL3210-1KE12-3U	1	6SL3210-1KE12-3A	1
	1.1 kW	3.1 A	6SL3210-1KE13-2U	1	6SL3210-1KE13-2A	1
	1.5 kW	4.1 A	6SL3210-1KE14-3U	1	6SL3210-1KE14-3A	1
	2.2 kW	5.6 A	6SL3210-1KE15-8U	1	6SL3210-1KE15-8A	1
	3.0 kW	7.3 A	6SL3210-1KE17-5U	1	6SL3210-1KE17-5A	1
	4.0 kW	8.8 A	6SL3210-1KE18-8U	1	6SL3210-1KE18-8A	1
 <p>Frame Size B</p>	5.5 kW	12.5 A	6SL3210-1KE21-3U	1	6SL3210-1KE21-3A	1
	7.5 kW	16.5 A	6SL3210-1KE21-7U	1	6SL3210-1KE21-7A	1
 <p>Frame Size C</p>	11.0 kW	25.0 A	6SL3210-1KE22-6U	1	6SL3210-1KE22-6A	1
	15.0 kW	31.0 A	6SL3210-1KE23-2U	1	6SL3210-1KE23-2A	1
	18.5 kW	37.0 A	6SL3210-1KE23-8U	1	6SL3210-1KE23-8A	1
SINAMICS G120C USS/MB (USS, Modbus RTU)				B		B
SINAMICS G120C DP (PROFIBUS DP)				P		P
SINAMICS G120C PN (PROFINET IO)				F		F
SINAMICS G120C CANopen				C		C

Figure 1-1 Identifying the converter

# Safety notes

# 2

It has to be ensured by the machine manufacturer, that the line-side overcurrent protection equipment interrupts within 5 s (immovable equipment and modules in immovable equipment) in the case of minimum fault current (current on complete insulation failure to accessible conductive parts that are not live during operation and maximum current loop resistance).

## General



### **WARNING**

This equipment controls potentially dangerous rotating mechanical parts.

Protection in case of direct contact by means of voltages < 60V (PELV = Protective Extra Low Voltage acc. to EN 61800-5-1) is only permissible in areas with equipotential bonding and in dry indoor rooms. If these conditions are not fulfilled, other protective measures against electric shock are to be taken, e.g., protective insulation.

The converter must always be properly grounded. Since the residual current for this product is greater than 3.5mA AC, a fixed ground connection is required, and the minimum size of the protective conductor must comply with local safety regulations for equipment with a high leakage current.

Install the converter on a metal mounting plate in a control cabinet. The mounting plate must not be painted and must have good electrical conductivity.

It is strictly prohibited for any mains disconnection to be performed on the motor-side of the system, if the converter is in operation and the output current is not equal to zero.

Take particular notice of the general and regional installation and safety regulations regarding work on dangerous voltage installations (e.g. 61800-5-1) as well as the relevant regulations regarding the correct use of tools and personal protective equipment (PPE).



### **CAUTION**

Static discharges on surfaces or interfaces (e.g. terminal or connector pins) can cause malfunctions or defects. ESD protective measures should therefore be observed when working with converters or converter components.

## Transport and storage

 **CAUTION**

Don't drop the converter or converter components during transport and storage. Protect the equipment from water (rainfall) and excessive temperatures.

## Installation and Commissioning

 **WARNING**

Wherever faults occurring in the control equipment can lead to substantial material damage or even grievous bodily injury (that is, potentially dangerous faults), additional external precautions must be taken or facilities provided to ensure or enforce safe operation, even when a fault occurs (e.g. independent limit switches, mechanical interlocks, etc.).

## Operation

 **DANGER**

Operating the converter outside the scope of the specification given in the technical specifications may cause malfunction or damage to the converter components. In exceptional cases there is the potential to cause overheating, danger of fire, damage to property, personal injury or loss of life.

 **WARNING**

Emergency stop facilities according to EN 60204, IEC 204 (VDE 0113) must remain operative in all operating modes of the control equipment. Any disengagement of the emergency stop facility must not lead to an uncontrolled or an undefined restart of the equipment.

 **WARNING**

Use of mobile radio devices (e.g. telephones, walkie-talkies) in the immediate vicinity of the devices (< 1.8 m) can interfere with the functioning of the equipment.

 **WARNING**

Filtered drives can only be used on power systems with grounded neutral point.

**! WARNING**

During operation and for a short time after switching-off the converter, the surfaces of the converter can reach a high temperature. Avoid coming into direct contact with the converter surface.

**! WARNING****Risk of fire**

If an unsuitable braking resistor is used, this could result in a fire and severely damage, people, property and equipment. Use the adequate braking resistor and install it correctly.

The temperature of a braking resistor increases significantly during operation. Avoid coming into direct contact with braking resistors.

## Repair

**! WARNING**

Repairs on equipment may only be carried out by Siemens Service, by repair centers authorized by Siemens or by authorized personnel who are thoroughly acquainted with all the warnings and operating procedures contained in this manual.

Any defective parts or components must be replaced using parts contained in the relevant spare parts list.

## Residual risks

The control and drive components of a power drive system (PDS) are approved for industrial and commercial use in industrial supply networks. Their use in public supply networks requires a different configuration and/or additional measures.

These components may only be operated in closed housings or in higher-level control cabinets with protective covers that are closed, and when all of the protective devices are used.

When carrying out a risk assessment of a machine in accordance with the EU Machinery Directive, the machine manufacturer must consider the following residual risks associated with the control and drive components of a PDS.

1. Unintentional movements of driven machine components during commissioning, operation, maintenance, and repairs caused by, for example:
  - Hardware defects and/or software errors in the sensors, controllers, actuators, and connection technology
  - Response times of the controller and drive
  - Operating and/or ambient conditions not within the scope of the specification
  - Condensation / conductive contamination
  - Parameterization, programming, cabling, and installation errors
  - Use of radio devices / cellular phones in the immediate vicinity of the controller
  - External influences / damages
2. Exceptionally high temperatures as well as emissions of noise, particles, or gas caused by, for example:
  - Component malfunctions
  - Software errors
  - Operating and/or ambient conditions not within the scope of the specification
  - External influences / damages
3. Hazardous shock voltages caused by, for example:
  - Component malfunctions
  - Influence of electrostatic charging
  - Induction of voltages in moving motors
  - Operating and/or ambient conditions not within the scope of the specification
  - Condensation / conductive contamination
  - External influences / damages
4. Electrical, magnetic and electromagnetic fields generated in operation that can pose a risk to people with a pacemaker, implants or metal replacement joints, etc. if they are too close.
5. Release of environmental pollutants or emissions as a result of improper operation of the system and/or failure to dispose of components safely and correctly.

## Installing

### 3.1 Mechanical installation

Table 3- 1 Dimensions, drill patterns and minimum distances

		Frame Size A 0.55 kW ... 4.0 kW	Frame Size B 5.5 kW ... 7.5 kW	Frame Size C 11 kW ... 18.5 kW	
	Height	196 mm	196 mm	295 mm	
	Width	73 mm	100 mm	140 mm	
	Depth of the converter with PROFINET interface	225.4 mm	225.4 mm	225.4 mm	
	Depth of the converter with USS/MB, CANopen or PROFIBUS interface	203 mm	203 mm	203 mm	
	+ Depth		+ 21 mm supplementary depth with the operator panel IOP snapped onto the converter.		
Distances to other equipment:			+ 6 mm supplementary depth with the operator panel BOP-2.		
		Drill pattern			
	Fixings	3 × M4 bolts 3 × M4 nuts 3 × M4 washers	4 × M4 bolts 4 × M4 nuts 4 × M4 washers	4 × M5 bolts 4 × M5 nuts 4 × M5 washers	
	Tightening torque	2.5 Nm	2.5 Nm	2.5 Nm	

### 3.2 Electrical installation

#### Connecting line, motor and further components

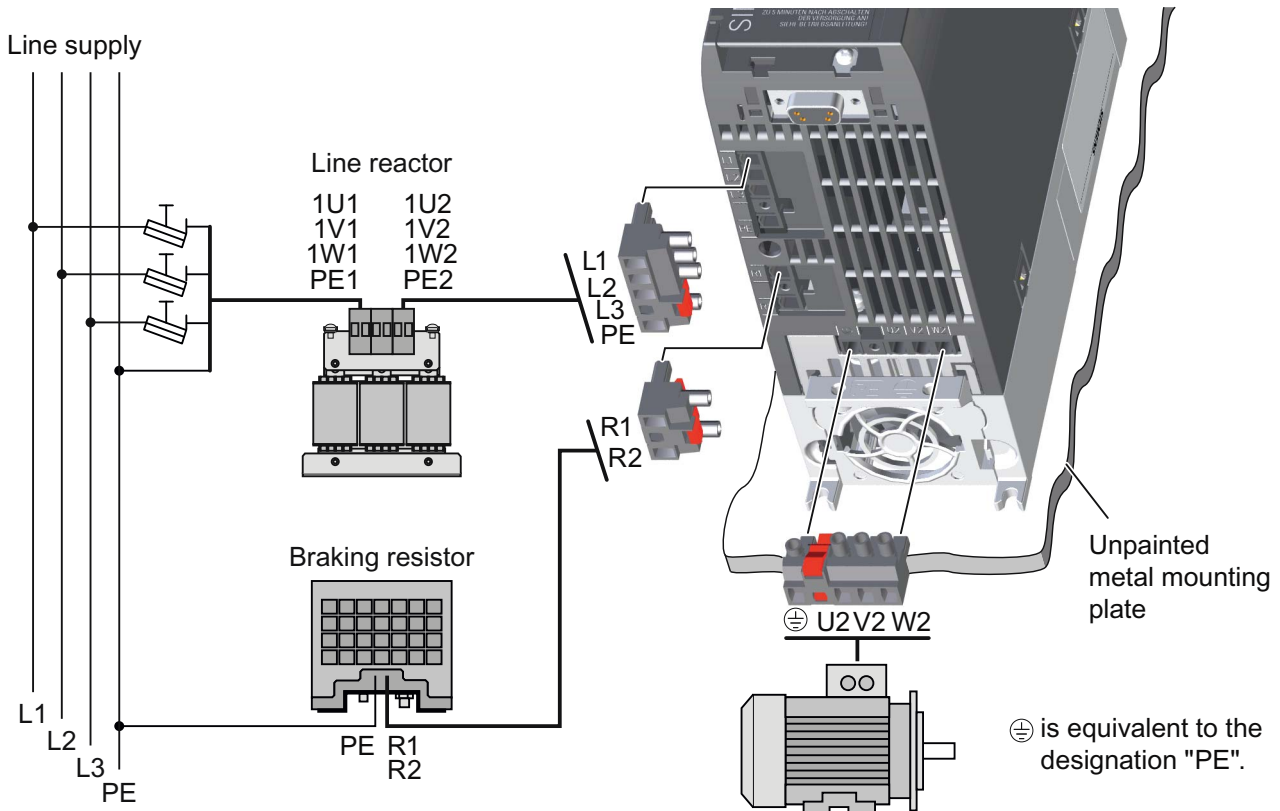

Converter	Standard fuse	UL/cUL fuse	Braking resistor	Line reactor
FSA	0.55 kW ... 1.1 kW	3NA3801 (6 A)	10 A class J	6SL3201-0BE14-3AA0
	1.5 kW			
	2.2 kW	6SL3203-0CE21-0AA0		
	3.0 kW ... 4.0 kW			3NA3803 (10 A)
FSB	5.5 kW	3NA3805 (16 A)	20 A class J	6SL3203-0CE21-8AA0
	7.5 kW			
	11 kW	3NA3810 (25 A)		
FSC	15 kW	3NA3817 (40 A)	40 A class J	6SL3201-0BE23-8AA0
	18.5 kW			
	11 kW ...	3NA3820 (50 A)		
	15 kW	3NA3822 (63 A)		

Converter	Cable cross section converter (tightening torque)		Line reactor (tightening torque)			Braking resistor (tightening torque)	
FSA	0.55 kW ... 4 kW	2.5 mm <sup>2</sup> (0.5 Nm)	4 mm <sup>2</sup> (0.8 Nm)	12 AWG (7 lbf in)	PE M4 (3 Nm / 26.5 lbf in)	2.5 mm <sup>2</sup> (0.5 Nm)	14 AWG (4.5 lbf in)
FSB	5.5 kW ... 7.5 kW	6 mm <sup>2</sup> (0.6 Nm)	10 mm <sup>2</sup> (1.8 Nm)	8 AWG (16 lbf in)	PE M5 (5 Nm / 44 lbf in)		
FSC	11 kW ... 18.5 kW	16 mm <sup>2</sup> (1.5 Nm)	16 mm <sup>2</sup> (4 Nm)	5 AWG (35 lbf in)		6 mm <sup>2</sup> (0.6 Nm)	10 AWG (5.5 lbf in)

### Components for United States / Canadian installations (UL/CSA)

In order that the system is UL/CSA-compliant, use UL/CSA-certified J-type fuses, overload circuit-breakers or intrinsically safe motor protection devices. For each frame size A to C use class 1 75° C copper wire only.

Install the converter with any external recommended suppressor with the following features:

- Surge-protective devices; device shall be a Listed Surge-protective device (Category code VZCA and VZCA7).
- Rated nominal voltage 480/277 V<sub>AC</sub>, 50/60 Hz, 3-phase.
- Clamping voltage V<sub>PR</sub> = 2000 V, I<sub>N</sub> = 3 kA min, MCOV = 550 V<sub>AC</sub>, SCCR = 40 kA.
- Suitable for Type 1 or Type 2 SPD application.
- Clamping shall be provided between phases and also between phase and ground.

### EMC compliant installation

Rules for EMC-compliant installation:

- Install the converter on a metal mounting plate. The mounting plate has to be unpainted and with a good electrical conductivity.
- Use shielded cables for the following connections:
  - Motor and motor temperature sensor
  - Braking resistor
  - Process interfaces (Field bus, digital and analog inputs and outputs)
- Use a clamp for connecting each shielded cable. Connect the shield to the mounting plate or to the shield plate through a good electrical connection and through the largest possible surface area.

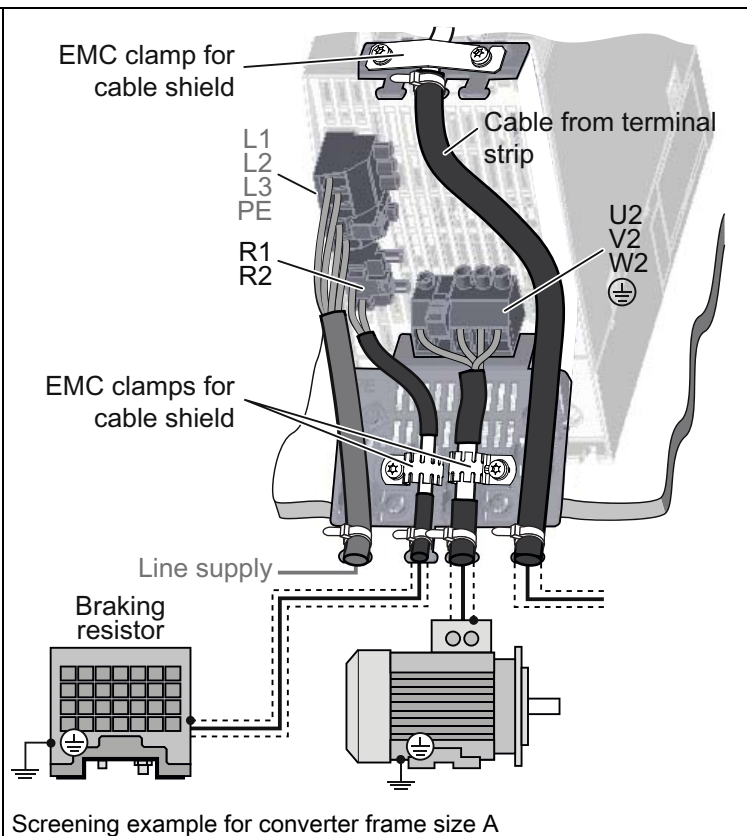
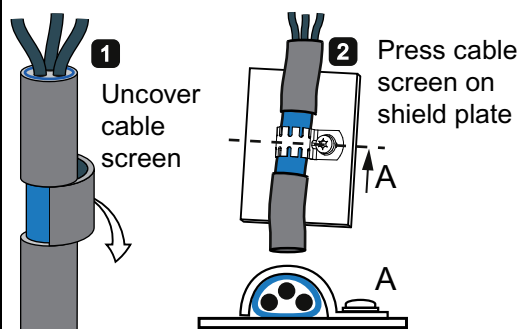

Overview of process and user interfaces

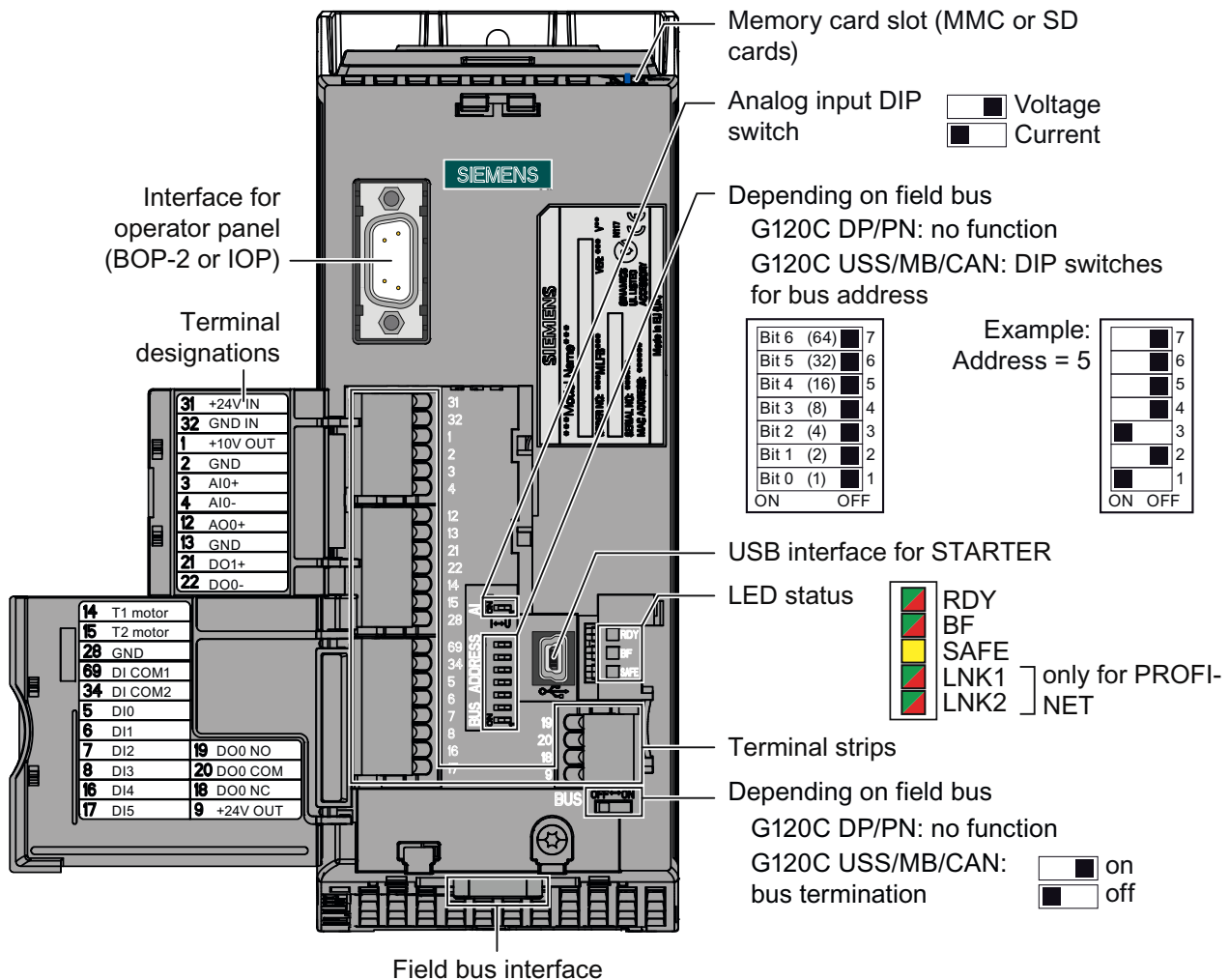

CANopen

1	Not used
2	CAN_L, CAN-signal (dominant low)
3	CAN_GND, CAN-reference
4	Not used
5	(CAN_SHLD), optional cable shield
6	(GND), optional CAN-reference
7	CAN_H, CAN-signal (dominant high)
8	Not used
9	Not used

USS / Modbus RTU

1	0 V, reference potential
2	RS485N, Receive and send (-)
3	RS485P, Receive and send (+)
4	Cable shield
5	Not used

PROFIBUS

1	Shield, ground connection
2	Not used
3	RxD/TxD-P, receive/send data P(B/B')
4	CNTR-P, control signal potential (C/C')
5	DGND, data reference potential
6	VP, supply voltage positive
7	Not used
8	RxD/TxD-N, receive/send data N(A/A')
9	Not used

PROFINET

1	RX+, receiver data +
2	RX-, receiver data -
3	TX+, transmission data +
4	Not used
5	Not used
6	TX-, transmission data -
7	Not used
8	Not used

### Wiring the terminal strip

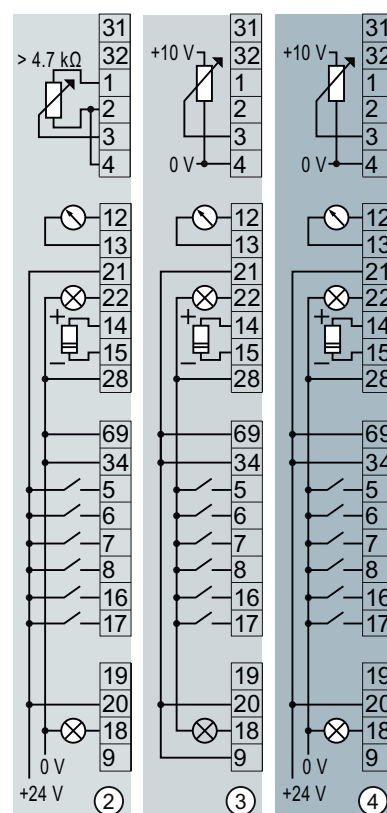
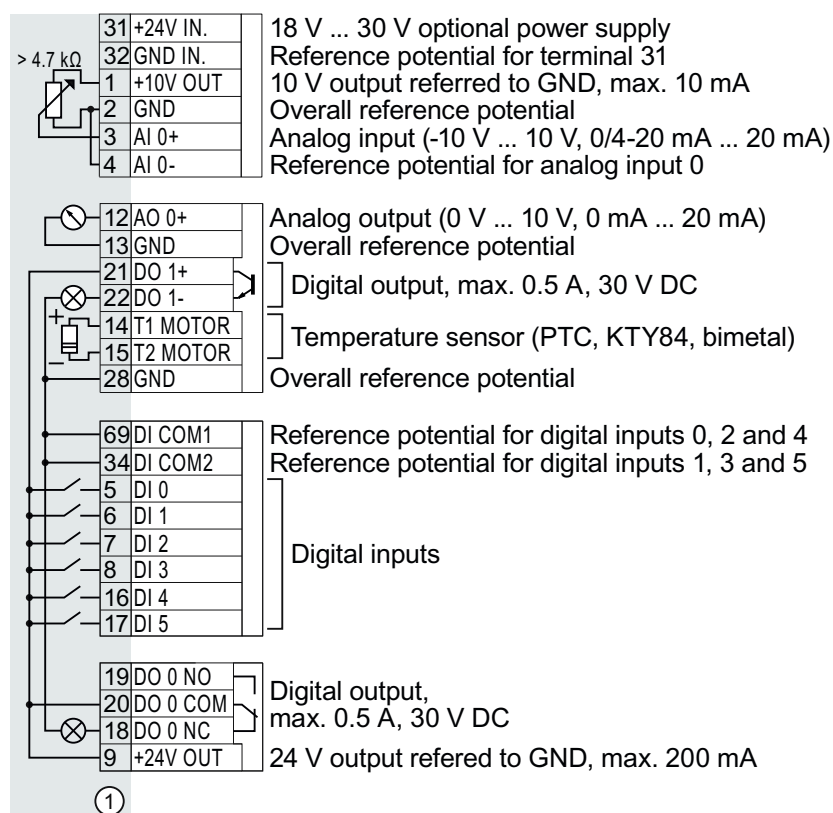

#### Wiring variants

- |  |                                       |
|--|---------------------------------------|
| ① Wiring using the internal power supply | Digital input = HIGH if switch closed |
| ② Wiring using an external power supply  | Digital input = HIGH if switch closed |
| ③ Wiring using the internal power supply | Digital input = LOW if switch closed  |
| ④ Wiring using an external power supply  | Digital input = LOW if switch closed  |

**Permissible cable cross-section:** 0.5 mm<sup>2</sup> (21 AWG) ... 1.5 mm<sup>2</sup> (16 AWG)  
**Recommended cable cross section:** 1 mm<sup>2</sup> (18 AWG)

#### EMC-compliant installation

- Use shielded cables for connecting the terminal strip to other components.
- Use a clamp for connecting the shielded cable. Connect the shield to the mounting plate or to the shield plate through a good electrical connection and through the largest possible surface area. The handling of shielded cables is shown in section Electrical installation (Page 10).

### 3.3 Pre-defined interface configurations

The converter offers different pre-defined settings for its interfaces. Select the appropriate setting (macro) when commissioning the inverter (see section: Commissioning (Page 19)) and wire the terminal strips according to the selection.

If none of the pre-defined settings suites your application completely, do the following steps:

1. Wire the terminal strips according to your application.
2. Choose the best fitting I/O configuration (macro).
3. Select your chosen I/O configuration (macro) during basic commissioning.
4. Change the function of the inappropriate terminals.

#### Fixed speeds

**Macro 1**  
**Two fixed speeds**  
 p1003 = Fixed speed 3  
 p1004 = Fixed speed 4  
 DI 4 and DI 5 = HIGH:  
 Inverter adds fixed speed 3 + fixed speed 4

5	DI 0	ON/OFF1 right	Fault	18	DO 0
6	DI 1	ON/OFF1 left		19	
7	DI 2	Acknowledge		20	
8	DI 3	---	Alarm	21	DO 1
16	DI 4	Fixed speed 3		22	
17	DI 5	Fixed speed 4			
3	AI 0	---	Speed	12	AO 0
4			0 V ... 10 V	13	

**Macro 2**  
**Two fixed speeds with safety function (STO)**  
 p1001 = Fixed speed 1  
 p1002 = Fixed speed 2  
 DI 0 and DI 1 = HIGH:  
 Motor runs with fixed speed 1 + fixed speed 2

5	DI 0	ON/OFF1 + Fixed speed 1	Fault	18	DO 0
6	DI 1	Fixed speed 2		19	
7	DI 2	Acknowledge		20	
8	DI 3	---	Alarm	21	DO 1
16	DI 4	Reserved for STO		22	
17	DI 5				
3	AI 0+	---	Speed	12	AO 0+
4			0 V ... 10 V	13	

See also section: Releasing "Safe Torque Off" (Page 26).

**Macro 3**  
**Four fixed speeds**  
 p1001 = Fixed speed 1  
 p1002 = Fixed speed 2  
 p1003 = Fixed speed 3  
 p1004 = Fixed speed 4  
 Several DI = HIGH:  
 Inverter adds corresponding fixed speeds

5	DI 0	ON/OFF1 + Fixed speed 1	Fault	18	DO 0
6	DI 1	Fixed speed 2		19	
7	DI 2	Acknowledge		20	
8	DI 3	---	Alarm	21	DO 1
16	DI 4	Fixed speed 3		22	
17	DI 5	Fixed speed 4			
3	AI 0+	---	Speed	12	AO 0+
4			0 V ... 10 V	13	

**Macro 4**  
Field bus PROFIBUS DP or PROFINET

5	DI 0	---		Fault	18	DO 0
6	DI 1	---			19	
7	DI 2	Acknowledge			20	
8	DI 3	---		Alarm	21	DO 1
16	DI 4	---			22	
17	DI 5	---				
3	AI 0	---		Speed	12	AO 0
4				0 V ... 10 V	13	

PROFIBUS DP  
PROFINET  
Telegramm 352

See also section: Description files for fieldbus configuration (Page 18).

**Macro 5**  
Field bus PROFIBUS DP or PROFINET with safety function (STO)

5	DI 0	---		Fault	18	DO 0
6	DI 1	---			19	
7	DI 2	Acknowledge			20	
8	DI 3	---		Alarm	21	DO 1
16	DI 4		Reserved for STO		22	
17	DI 5					
3	AI 0	---		Speed	12	AO 0
4				0 V ... 10 V	13	

PROFIBUS DP  
PROFINET  
Telegramm 352

See also sections: Releasing "Safe Torque Off" (Page 26), Description files for fieldbus configuration (Page 18).

### Automatic / Manual - change over from field bus to jog

Factory setting with G120C DP and G120C PN:

**Macro 7** DI 3 = LOW  
Field bus PROFIBUS DP or PROFINET

5	DI 0	---		Fault	18	DO 0
6	DI 1	---			19	
7	DI 2	Acknowledge			20	
8	DI 3	LOW		Alarm	21	DO 1
16	DI 4	---			22	
17	DI 5	---				
3	AI 0	---		Speed	12	AO 0
4				0 V ... 10 V	13	

PROFIBUS DP  
PROFINET  
Telegramm 1

DI 3 = HIGH  
Jog via DI 0 and DI 1

5	DI 0	Jog speed 1		Fault	18	DO 0
6	DI 1	Jog speed 2			19	
7	DI 2	Acknowledge			20	
8	DI 3	HIGH		Alarm	21	DO 1
16	DI 4	---			22	
17	DI 5	---				
3	AI 0	---		Speed	12	AO 0
4				0 V ... 10 V	13	

p1058 = Jog speed 1  
p1059 = Jog speed 2

See also section: Description files for fieldbus configuration (Page 18).

Motorized potentiometer

Macro 8  
Motorized potentiometer (MOP)  
with safety function (STO)

5	DI 0	ON/OFF1	Fault	18	DO 0
6	DI 1	MOP up		19	
7	DI 2	MOP down		20	
8	DI 3	Acknowledge	Alarm	21	DO 1
16	DI 4	Reserved for STO		22	
17	DI 5				
3	AI 0	---	Speed	12	AO 0
4			0 V ... 10 V	13	

See also section: Releasing "Safe Torque Off" (Page 26).

Macro 9  
Motorized potentiometer  
(MOP)

5	DI 0	ON/OFF1	Fault	18	DO 0
6	DI 1	MOP up		19	
7	DI 2	MOP down		20	
8	DI 3	Acknowledge	Alarm	21	DO 1
16	DI 4	---		22	
17	DI 5	---			
3	AI 0	---	Speed	12	AO 0
4			0 V ... 10 V	13	

Analog setpoint

Macro 13  
Safety function (STO)

5	DI 0	ON/OFF1	Fault	18	DO 0
6	DI 1	Reverse		19	
7	DI 2	Acknowledge		20	
8	DI 3	---	Alarm	21	DO 1
16	DI 4	Reserved for STO		22	
17	DI 5				
3	AI 0	Setpoint	Speed	12	AO 0
4		I□■U -10 V ... 10 V	0 V ... 10 V	13	

See also section: Releasing "Safe Torque Off" (Page 26).

Process industry

Macro 14  
DI 3 = LOW  
Field bus PROFIBUS DP  
or PROFINET

5	DI 0	---	Fault	18	DO 0
6	DI 1	External fault		19	
7	DI 2	Acknowledge		20	
8	DI 3	LOW	Alarm	21	DO 1
16	DI 4	---		22	
17	DI 5	---			
3	AI 0	---	Speed	12	AO 0
4			0 V ... 10 V	13	

DI 3 = HIGH  
Motorized potentiometer (MOP)

5	DI 0	ON/OFF1	Fault	18	DO 0
6	DI 1	External fault		19	
7	DI 2	Acknowledge		20	
8	DI 3	HIGH	Alarm	21	DO 1
16	DI 4	MOP up		22	
17	DI 5	MOP down			
3	AI 0	---	Speed	12	AO 0
4			0 V ... 10 V	13	

PROFIBUS DP  
PROFINET  
Telegramm 20

See also section: Description files for fieldbus configuration (Page 18).

**Macro 15** DI 3 = LOW  
Analog setpoint

5	DI 0	ON/OFF1	Fault	18	DO 0
6	DI 1	External fault		19	
7	DI 2	Acknowledge		20	
8	DI 3	LOW	Alarm	21	DO 1
16	DI 4	---		22	
17	DI 5	---			
3	AI 0	Setpoint	Speed	12	AO 0
4		I□■U -10 V ... 10 V	0 V ... 10 V	13	

**DI 3 = HIGH**  
Motorized potentiometer (MOP)

5	DI 0	ON/OFF1	Fault	18	DO 0
6	DI 1	External fault		19	
7	DI 2	Acknowledge		20	
8	DI 3	HIGH	Alarm	21	DO 1
16	DI 4	MOP up		22	
17	DI 5	MOP down			
3	AI 0	---	Speed	12	AO 0
4			0 V ... 10 V	13	

**Two or three wire control**

Macro 12 is factory setting with the G120C USS/MB and G120C CAN.

	Macro 12	Macro 17	Macro 18
Two wire control	Mode 1	Mode 2	Mode 3
Control command 1	ON/OFF1	ON/OFF1 right	ON/OFF1 right
Control command 2	Reverse	ON/OFF1 left	ON/OFF1 left

5	DI 0	Control command 1	Fault	18	DO 0
6	DI 1	Control command 1		19	
7	DI 2	Acknowledge		20	
8	DI 3	---	Alarm	21	DO 1
16	DI 4	---		22	
17	DI 5	---			
3	AI 0	Setpoint	Speed	12	AO 0
4		I□■U -10 V ... 10 V	0 V ... 10 V	13	

	Macro 19	Macro 20
Three wire control	Mode 1	Mode 2
Control command 1	Release/ OFF1	Release/ OFF1
Control command 2	ON right	ON
Control command 3	ON left	Reverse

5	DI 0	Control command 1	Fault	18	DO 0
6	DI 1	Control command 2		19	
7	DI 2	Control command 3		20	
8	DI 3	Acknowledge	Alarm	21	DO 1
16	DI 4	---		22	
17	DI 5	---			
3	AI 0	Setpoint	Speed	12	AO 0
4		I□■U -10 V ... 10 V	0 V ... 10 V	13	

**Communication with the higher-level control via USS**

**Macro 21**  
Field bus USS

p2020 = baud rate  
p2022 = Number of PZD  
p2023 = Number of PKW



5	DI 0	---	Fault	18	DO 0
6	DI 1	---		19	
7	DI 2	Acknowledge		20	
8	DI 3	---	Alarm	21	DO 1
16	DI 4	---		22	
17	DI 5	---			
3	AI 0	---	Speed	12	AO 0
4			0 V ... 10 V	13	



USS  
38400 baud  
2 PZD, PKW variable

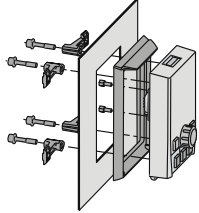
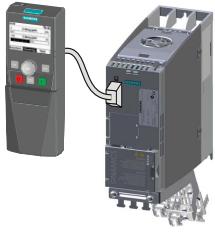
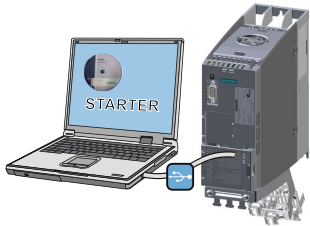

## Commissioning

### Accessories for commissioning and data backup

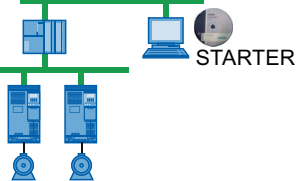
Operator Panels for commissioning, diagnostics and controlling converters		Order number
	<p>BOP-2 (Basic Operator Panel) - for snapping onto the frequency converter</p> <ul style="list-style-type: none"> <li>• Copying of drive parameters</li> <li>• Two-line display</li> <li>• Guided basic commissioning</li> </ul>	6SL3255-0AA00-4CA1
	<p>IOP (Intelligent Operator Panel) - for snapping onto the frequency converter</p> <ul style="list-style-type: none"> <li>• Copying of drive parameters</li> <li>• Plain text display</li> <li>• Menu-based operation and application wizards</li> </ul>	6SL3255-0AA00-4JA0
	<p>Door mounting kit for IOP/BOP-2</p> <ul style="list-style-type: none"> <li>• For installation of the BOP-2 or IOP in a control cabinet door.</li> <li>• Degree of protection with IOP: IP54 or UL Type 12</li> <li>• Degree of protection with BOP-2: IP55</li> </ul>	6SL3256-0AP00-0JA0
	<p>IOP - with handheld For mobile use of the IOP</p>	6SL3255-0AA00-4HA0
PC tools for commissioning, diagnostics and controlling of the converter		
	<p>PC Connection Kit Includes a STARTER DVD and USB port.</p>	6SL3255-0AA00-2CA0

	STARTER Commissioning tool (PC software) connected to the converter via USB port, PROFIBUS or PROFINET Downloading: STARTER <a href="http://support.automation.siemens.com/WW/view/en/10804985/130000">http://support.automation.siemens.com/WW/view/en/10804985/130000</a>	STARTER on the DVD: 6SL3072-0AA00-0AG0
	Drive ES Basic As an option to STEP 7 with routing function via network limits for PROFIBUS and PROFINET	6SW1700-5JA00-5AA0
<b>Memory cards:</b> to save and transfer the converter settings		
	MMC card SD card	6SL3254-0AM00-0AA0 6ES7954-8LB00-0AA0

### Commissioning with IOP

The commissioning with the IOP can be done intuitively by using the commissioning wizards and the help texts included in the IOP. For further information refer to the IOP Operating Instructions.



### Commissioning with STARTER

The most important steps:

- Connect the PC to the converter via USB and start the STARTER tool.
- Choose the project wizard (menu "Project / New with assistant")
  - In the project wizard choose "Find drive units online"
  - Select USB as interface (Access point of the application: "DEVICE ...", interface parameter assignment used: "S7USB")
  - Finish the project wizard.
- STARTER has now created your project and inserted a new drive
- Select the drive in your project and go online 
- In your drive open the "Configuration" mask (double click)
- Start basic commissioning with the "Assistent" button

For further information refer to converter operating instructions.

Installing the basic operator panel BOP-2 and selecting basic commissioning

1. Remove the blind cover on the converter.
2. A: Place the bottom edge of the BOP-2 casing into the lower recess of the converter housing.  
B: Push the BOP-2 towards the converter until the release-catch clicks into place on the converter housing.
3. Wait until the operator panel displays setpoint [1/min] and speed [1/min].
4.  Press the ESC key.
5.  Press one of the arrow keys until the operator panel displays the SETUP menu.
6.  In the SETUP menu press the OK button to start the basic commissioning.







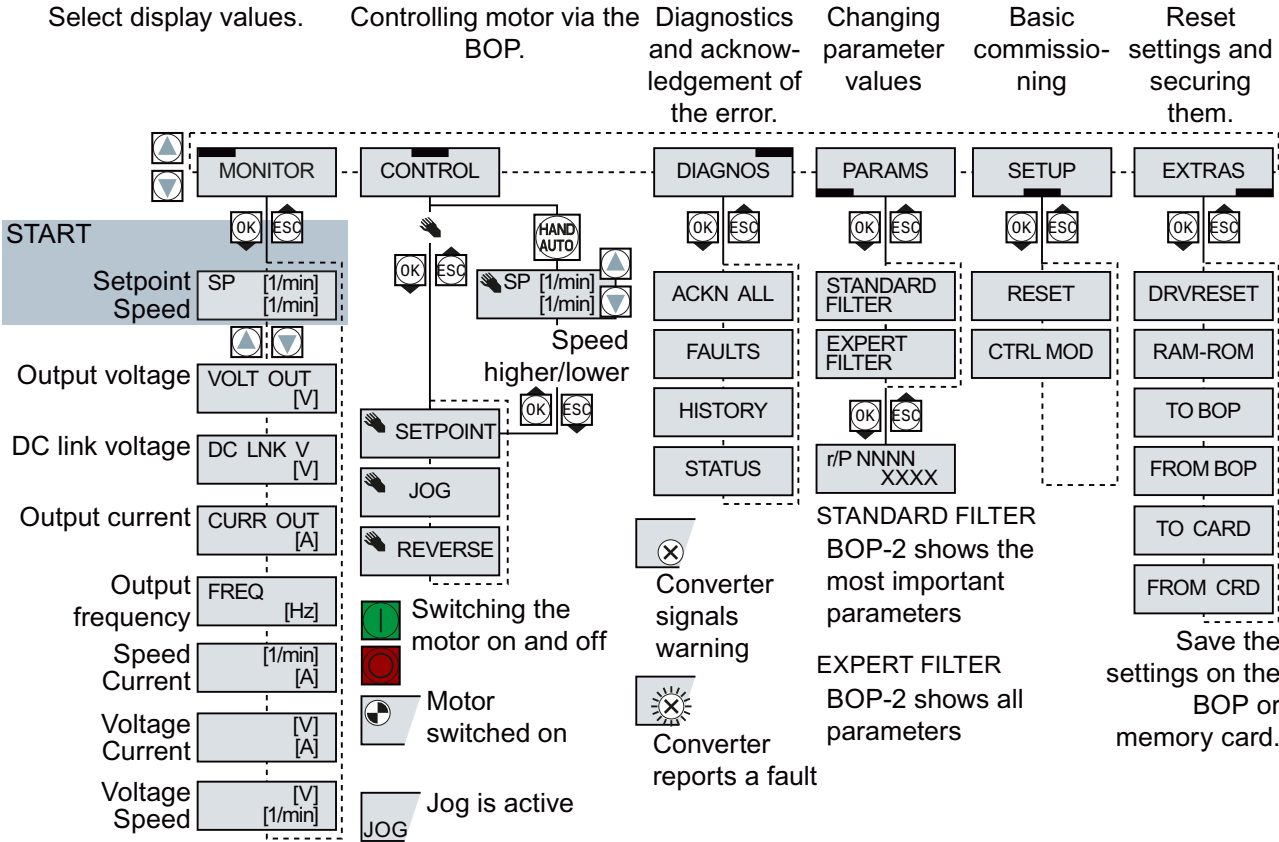















Futher steps see next section (Page 22).

Overview of the BOP-2 menu





## 4.1 Basic commissioning with BOP-2

The basic commissioning sets the most important data of the drive.

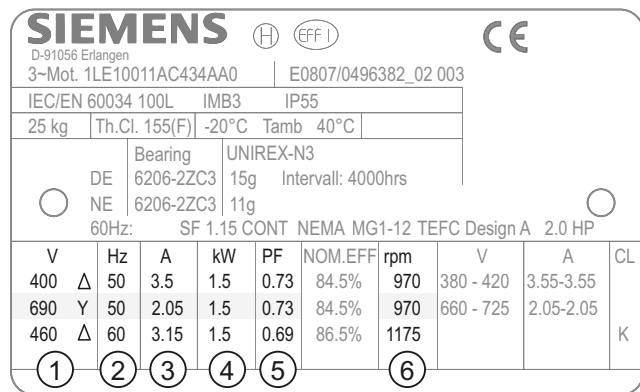
- SETUP**  The "SETUP" menu guides you step by step through the basic commissioning of the drive.
1. **RESET**  Select Reset if you wish to reset all parameters to the factory setting before the basic commissioning: nO → YES → OK
  2. **CTRL MOD**  Select the motor control mode. The most important control modes are:
    - VF LIN                      V/f control with linear characteristic
    - VF QUAD                    V/f control with square-law characteristic
    - SPD N EN                  Closed loop speed control (vector control)
  3. **EUR/USA**  **P100**  ② IEC or NEMA standard
  4. **MOT VOLT**  **P304**  ① Voltage
  5. **MOT CURR**  **P305**  ③ Current
  6. **MOT POW**  **P307**  ④ Power IEC (kW)  
 ⑤ Power NEMA (HP)      ⑥ Speed      Set the motor data on the rating plate
  7. **MOT RPM**  **P311**  ⑥ Speed
  8. **MOT ID**  **P1900**  We recommend the setting STIL ROT (Identify motor data at standstill and with the motor rotating).  
 If one of the following cases applies, select the setting STILL (identify motor data at standstill):
    - You have selected the "Speed control" control mode, but the motor cannot rotate freely, e.g. for mechanically limited traversing sections.
    - You have set "V/f control" as control mode.
  9. **MAc PAR**  **P15**  Select the configuration for the inputs and outputs, as well as the correct fieldbus for your application. The predefined configurations can be found in the section titled Pre-defined interface configurations (Page 14).
  10. **MIN RPM**  **P1080**  Set the minimum motor speed.
  11. **RAMP UP**  **P1120**  Set the motor ramp-up time.





**SIEMENS**   

D-91056 Erlangen  
 3-Mot. 1LE10011AC434AA0 | E0807/0496382\_02 003

IEC/EN 60034 100L		IMB3		IP55					
25 kg	Th.Cl. 155(F)	-20°C	Tamb 40°C						
Bearing		UNIREX-N3							
DE	6206-2ZC3	15g	Intervall: 4000hrs						
NE	6206-2ZC3	11g							
60Hz: SF 1.15 CONT NEMA MG1-12 TEFC Design A 2.0 HP									
V	Hz	A	kW	PF	NOM.EFF	rpm	V	A	CL
400 Δ	50	3.5	1.5	0.73	84.5%	970	380 - 420	3.55-3.55	K
690 Y	50	2.05	1.5	0.73	84.5%	970	660 - 725	2.05-2.05	
460 Δ	60	3.15	1.5	0.69	86.5%	1175			

① ② ③ ④ ⑤ ⑥

12.  Set the motor ramp-down time.
13.  Confirm that the basic commissioning has been completed:  
nO → YES → OK

### Motor data identification and self-optimization







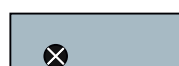

If you select the MOT ID (p1900) during basic commissioning, an alarm will be issued once the basic commissioning has been completed.

For the motor data identification, the motor must be cold. A motor in a warm operational condition supplies unusable measurement results.

 <b>CAUTION</b>
<b>Motor data identification for dangerous loads</b>
Secure dangerous plant and system parts before starting the motor data identification, e.g. by fencing off the dangerous location or lowering a suspended load to the floor.



The converter issues an alarm (alarm A07991).

1.  ⇒  Press the HAND/AUTO button. The BOP-2 displays the HAND icon.
2.  Switch on the motor.
3.  Wait until the converter switches off the motor after the motor data identification has been completed. This procedure takes several seconds.
-  If, in addition to the motor data identification, you have also selected a rotating measurement, the converter issues again alarm A07991.
4.  Switch on again the motor.
5.  Wait until the converter switches off the motor after the speed controller has been optimized. This procedure can take up to one minute.
6.  Switch over from HAND to AUTO.

Now you have finished the basic commissioning and the motor identification.

## 4.2 Further settings

### Changing settings using BOP-2

With the BOP-2 you change your converter settings by selecting a parameter via its number (e.g. p0327) and by changing the value of the parameter change.

In the parameters starting with an "r" (for example r0020), the converter will display internal values. You cannot change the value of an r-parameter.

The converter immediately saves all settings which you made using the BOP-2 so that they are protected against power failure.

#### Procedure

Select the parameters		Changing a parameter value	
If the parameter number flashes in the display, you have two options for changing the number:		If the parameter value flashes in the display, you have two options of changing the value:	
1. option:	2. option:	1. option:	2. option:
<ul style="list-style-type: none"> <li>Increase or decrease the parameter number using the arrow keys until the number you want is displayed.</li> </ul>	<ul style="list-style-type: none"> <li>Press and hold the OK key for more than two seconds and change the required parameter number digit by digit.</li> </ul>	<ul style="list-style-type: none"> <li>Increase or decrease the parameter value using the arrow keys until the value you want is displayed.</li> </ul>	<ul style="list-style-type: none"> <li>Press and hold the OK key for more than two seconds and enter the required value digit by digit.</li> </ul>
<ul style="list-style-type: none"> <li>Confirm the parameter number using the OK key.</li> </ul>		<ul style="list-style-type: none"> <li>Confirm the parameter value using the OK key.</li> </ul>	

### 4.2.1 Changing the function of terminals

Terminals	Procedure	Examples
<p>Digital inputs</p>	<ol style="list-style-type: none"> <li>Select the desired function indicated by a "BI"-parameter.</li> <li>Set this parameter to the value of the status parameter r0722.x of the desired digital input.</li> </ol>	<p><i>Function:</i> Switch on the motor with DI 2.</p> <p><i>Setting with BOP-2:</i></p> <pre>P840 [00] r722.2</pre>
	<p>If you have set macro 7, macro 14 or macro 15 (see page (Page 14)) for the converter interfaces, you have to input the appropriate parameter index for changing the function of a terminal:</p> <p>DI 3 = low: parameter index = [00] DI 3 = high: parameter index = [01]</p>	
<p>Digital outputs</p>	<ol style="list-style-type: none"> <li>Select the desired function indicated by a "BO"-parameter.</li> <li>Set the parameter p073x of the desired digital output to the value of the "BO"-parameter.</li> </ol>	<p><i>Function:</i> DO 1 provides the "fault" signal.</p> <p><i>Setting with BOP-2:</i></p> <pre>P731 r52.3</pre>
<p>Analog input</p> <p>-10 V ... 10 V I <input type="checkbox"/> U p0756[0] 0 V ... 10 V I <input type="checkbox"/> U -20 mA ... 20 mA I <input type="checkbox"/> U 0 mA ... 20 mA I <input type="checkbox"/> U</p>	<ol style="list-style-type: none"> <li>Select the desired function indicated by a "CI"-parameter.</li> <li>Set this parameter to the value of the status parameter r0755 of the analog input.</li> </ol>	<p><i>Function:</i> AI 0 provides the setpoint for the PID controller.</p> <p><i>Setting with BOP-2:</i></p> <pre>P2253 [00] r755 [00]</pre>
	<p>Use p0756[0] and the I/U switch on the converter front for setting a voltage or current input.</p> <p>If you have set macro 7, macro 14 or macro 15 (see page (Page 14)) for the converter interfaces, you have to input the appropriate parameter index for changing the function of a terminal:</p> <p>DI 3 = low: parameter index = [00] DI 3 = high: parameter index = [01]</p>	

4.2 Further settings

Terminals	Procedure	Examples				
<p>Analog output</p> <p>0 V ... 10 V 0 mA ... 20 mA</p>	<ol style="list-style-type: none"> <li>Select the desired function indicated by a "CO"-parameter.</li> <li>Set the parameter p0771 of the analog output to the value of the "CO"-parameter.</li> </ol>	<p><i>Function:</i> AO 0 provides the "current" signal.</p> <p><i>Setting with BOP-2:</i></p> <table border="1"> <tr> <td>P771</td> <td>[00]</td> </tr> <tr> <td>r27</td> <td>[00]</td> </tr> </table>	P771	[00]	r27	[00]
P771	[00]					
r27	[00]					
<p>Use parameter p0776[0] for setting a voltage or current output.</p>						

4.2.2 Releasing "Safe Torque Off"

Terminals	Set the following parameters for releasing STO:	
<p>Fail-safe digital input</p>	p0010 = 95	Enter commissioning of fail-safe functions
	p9761 = ...	Enter password for fail-safe function (factory setting = 0)
	p9762 = ...	Enter new password, if required (0 ... FFFF FFFF)
	p9763 = ...	Confirm new password
	p9601.0 = 1	STO is selected via terminal strip
	p9659 = ...	Set the forced checking procedure timer. To fulfill the requirements of standards ISO 13849-1 and IEC 61508 regarding timely error detection, the converter must regularly test its safety-relevant circuits to ensure that they function correctly.
	p9700 = D0	Copy fail-safe parameters
	p9701 = DC	Confirm fail-safe parameters
	p0010 = 0	Finish commissioning of fail-safe functions

### 4.2.3 Parameter list

The following list contains the basic parameter information with access level 1 ... 3. The complete parameter list is provided in the list manual, see Product support (Page 49).

P-No.	Note
<b>Operation and visualization</b>	
r0002	Drive operating display
p0003	Access level
p0010	Drive, commissioning parameter filter
p0015	Macro drive unit See also Pre-defined interface configurations (Page 14).
r0018	Control Unit firmware version
r0020	Speed setpoint smoothed [100 % $\pm$ p2000]
r0021	CO: Actual speed smoothed [100 % $\pm$ p2000]
r0022	Speed actual value rpm smoothed [rpm]
r0024	Output frequency smoothed [100 % $\pm$ p2000]
r0025	CO: Output voltage smoothed [100 % $\pm$ p2001]
r0026	CO: DC link voltage smoothed [100 % $\pm$ p2001]
r0027	CO: Absolute actual current smoothed [100 % $\pm$ p2002]
r0031	Actual torque smoothed [100 % $\pm$ p2003]
r0032	CO: Active power actual value smoothed [100 % $\pm$ r2004]
r0034	Motor utilization [100 $\pm$ 100%]
r0035	CO: Motor temperature [100°C $\pm$ p2006]
r0036	CO: Power unit overload I <sup>2</sup> t [100 $\pm$ 100%]
r0039	Energy consumption
p0040	0 $\rightarrow$ 1   Reset the energy consumption display
r0041	Energy usage saved/energy saved
p0045	Smoothing time constant, display values [ms]
r0046	CO/BO: Missing enable signals
r0047	Motor data identification routine and speed controller optimization
r0050	CO/BO: Command Data Set CDS effective
r0051	CO/BO: Drive Data Set DDS effective
r0052	CO/BO: Status word 1
	.00   Ready to start
	.01   Ready
	.02   Operation enabled
	.03   Fault active
.04   Coast down active (OFF2)	

P-No.	Note	
	.05   Quick stop active (OFF3)	
	.06   Closing lockout active	
	.07   Alarm active	
	.08   Deviation, setpoint/actual speed	
	.09   Control requested	
	.10   Maximum speed reached	
	.11   I,M,P limit reached	
	.12   Motor holding brake open	
	.13   Alarm overtemperature motor	
	.14   Motor rotates forwards	
	.15   Alarm inverter overload	
	r0053	CO/BO: Status word 2
	r0054	CO/BO: Control word 1
		.00   ON/OFF1
		.01   OFF2
.02   OFF3		
.03   Enable ramp-function generator		
.04   Enable ramp-function generator		
.05   Continue ramp-function generator		
.06   Enable speed setpoint		
.07   Acknowledge fault		
.08   Jog bit 0		
.09   Jog bit 1		
.10   Master control by PLC		
.11   Direction reversal (setpoint)		
.13   Motorized potentiometer, raise		
.14   Motorized potentiometer, lower		
.15   CDS bit 0		
r0055	CO/BO: Supplementary control word	
	.00   Fixed setpoint, bit 0	
	.01   Fixed setpoint, bit 1	
	.02   Fixed setpoint, bit 2	
	.03   Fixed setpoint, bit 3	
	.04   DDS selection, bit 0	
	.05   DDS selection, bit 1	
	.08   Technology controller enable	
	.09   DC braking enable	
	.11   Droop enable	
	.12   Closed-loop torque control active	
	.13   External fault 1 (F07860)	
	.15   CDS bit 1	
	r0056	CO/BO: Status word, closed-loop control

4.2 Further settings

P-No.	Note
r0060	CO: Speed setpoint before setpoint filter [100 % ± p2000]
r0062	CO: Speed setpoint after filter [100 % ± p2000]
r0063	CO: Speed actual value unsmoothed [100 % ± p2000]
r0064	CO: Speed controller system deviation [100 % ± p2000]
r0065	Slip frequency [100 % ± p2000]
r0066	CO: Output frequency [100 % ± p2000]
r0067	CO: Output current, maximum [100 % ± p2002]
r0068	CO: Absolute current actual value unsmoothed [100 % ± p2002]
r0070	CO: Actual DC link voltage [100 % ± p2001]
r0071	Maximum output voltage [100 % ± p2001]
r0072	CO: Output voltage [100 % ± p2001]
r0075	CO: Current setpoint field-generating [100 % ± p2002]
r0076	CO: Current actual value field-generating [100 % ± p2002]
r0077	CO: Current setpoint torque-generating [100 % ± p2002]
r0078	CO: Current actual value torque-generating [100 % ± p2002]
r0079	CO: Torque setpoint, total [100 % ± p2003]
<b>Commissioning</b>	
p0100	IEC/NEMA motor standard
	0 IEC motor (50 Hz, SI units)
	1 NEMA motor (60 Hz, US units)
	2 NEMA motor (60 Hz, SI units)
P0124	CU Identification via LED
p0170	Number of Command Data Sets (CDS)
p0180	Number of Drive Data Sets (DDS)
<b>Power Module</b>	
p0201	Power unit code number
r0204	Power unit, hardware properties
p0205	Power unit application
	0 Load cycle with high overload
	1 Load cycle with light overload
r0206	Rated power unit power [kw/hp]
r0207	Rated power unit current
r0208	Rated power unit line supply voltage [V]
r0209	Power unit, maximum current

P-No.	Note
p0210	Drive unit line supply voltage [V]
p0230	Drive filter type, motor side
	0 No filter
	1 Motor reactor
	2 dv/dt filter
	3 Siemens sine-wave filter
	4 Sine wave filter, third-party manufacturer
p0233	Power unit motor reactor [mH]
p0234	Power unit sine-wave filter capacitance [µF]
r0238	Internal power unit resistance
p0278	DC link voltage undervoltage threshold reduction [V]
p0287	Ground fault monitoring thresholds [100 % ± r0209]
r0289	CO: Maximum power unit output current [100 % ± p2002]
p0290	Power unit overload response
	0 Reduce output current or output frequency
	1 No reduction, shutdown when overload threshold is reached
	2 Reduce I_output or f_output and f_pulse (not using I2t).
	3 Reduce the pulse frequency (not using I2t)
p0292	Power unit temperature alarm threshold [°C]
p0295	Fan run-on time [s]
<b>Motor</b>	
p0300	Motor type selection
	0 No motor
	1 Induction motor
	2 Synchronous motor
	17 1LA7 standard induction motor
p0301	Motor code number selection
p0304	Rated motor voltage [V]
p0305	Rated motor current [A]
p0306	Number of motors connected in parallel
p0307	Rated motor power [kW]
p0308	Rated motor power factor
p0309	Rated motor efficiency [%]
p0310	Rated motor frequency [Hz]
p0311	Rated motor speed [rpm]
p0320	Motor rated magnetizing current/short-circuit current [A]
p0322	Maximum motor speed [rpm]

P-No.	Note				
p0323	Maximum motor current [A]				
r0330	Rated motor slip				
r0331	Actual motor magnetizing current/short-circuit current				
r0333	Rated motor torque [Nm]				
p0335	Motor cooling type				
p0340	Automatic calculation of motor/control parameters				
p0341	Motor moment of inertia [kgm <sup>2</sup> ]				
p0342	Ratio between the total and motor moment of inertia [kgm <sup>2</sup> ]				
r0345	Nominal motor starting time				
p0346	Motor excitation build-up time [s]				
p0347	Motor de-excitation time [s]				
p0350	Motor stator resistance, cold [Ω]				
p0352	Cable resistance [Ω]				
r0395	Actual stator resistance				
r0396	Actual rotor resistance				
<b>Technology and units</b>					
p0500	Technology application				
p0505	Selecting the system of units				
1	System of units SI				
2	Referred system of units/SI				
3	US system of units				
4	System of units, referred/US				
p0573	Inhibit automatic reference value calculation				
p0595	Selecting technological units				
1	%	2	1 referred, no dimensions		
3	bar	4	°C	5	Pa
6	ltr/s	7	m <sup>3</sup> /s	8	ltr/min
9	m <sup>3</sup> /min	10	ltr/h	11	m <sup>3</sup> /h
12	kg/s	13	kg/min	14	kg/h
15	t/min	16	t/h	17	N
18	kN	19	Nm	20	psi
21	°F	22	gallon/s	23	inch <sup>3</sup> /s
24	gallon/min	25	inch <sup>3</sup> /min	26	gallon/h
27	inch <sup>3</sup> /h	28	lb/s	29	lb/min
30	lb/h	31	lbf	32	lbf ft
33	K	34	rpm	35	parts/min
36	m/s	37	ft <sup>3</sup> /s	38	ft <sup>3</sup> /min
39	BTU/min	40	BTU/h	41	mbar
42	inch wg	43	ft wg	44	m wg
45	% r.h.	46	g/kg		

P-No.	Note
p0596	Reference quantity, technological units
<b>Thermal motor monitoring and motor model, maximum current</b>	
p0601	Motor temperature sensor type
0	No sensor
1	PTC warning & timer
2	KTY84
4	Bimetallic NC contact warning & timer
p0604	Motor temperature alarm threshold [°C]
p0605	Motor temperature fault threshold [°C]
p0610	Motor overtemperature response
0	No response, alarm only, no reduction of I <sub>max</sub>
1	Alarm with reduction of I <sub>max</sub> and fault
2	Alarm and fault, no reduction of I <sub>max</sub>
p0611	I2t motor model thermal time constant [s]
p0615	I2t motor model fault threshold [°C]
p0625	Motor ambient temperature [°C]
p0637	Q flux, flux gradient saturated [mH]
p0640	Current limit [A]
<b>Command sources and terminals on the Control Unit</b>	
p0700	Command source selection
r0720	CU number of inputs and outputs
r0722	CO/BO: CU digital inputs, status
.00	DI 0 (terminal 5)
.01	DI 1 (terminal 6)
.02	DI 2 (terminal 7)
.03	DI 3 (terminal 8)
.04	DI 4 (terminal 16)
.05	DI 5 (terminal 17)
.11	DI 11 (terminals 3, 4) AI 0
r0723	CO/BO: CU digital inputs, status inverted
p0730	BI: CU signal source for terminal DO 0 NO: Terminal 19 / NC: Terminal 18
p0731	BI: CU signal source for terminal DO 1 NO: Terminal 21
r0747	CU, digital outputs status
p0748	CU, invert digital outputs
r0751	BO: CU analog inputs status word
r0752	CO: CU analog inputs input voltage/current actual AI0 (terminals 3/4)

P-No.	Note
r0755	CO: CU analog inputs actual value in percent, AI0 (terminals 3/4) [100 ± 100%]
p0756	CU analog input type (terminals 3, 4)
	0   Unipolar voltage input (0 V ... +10 V)
	1   Unipolar voltage input monitored (+2 V... +10 V)
	2   Unipolar current input (0 mA ... +20 mA)
	3   Unipolar current input monitored (+4 mA ... +20 mA)
	4   Bipolar voltage input (-10 V...+10 V)
8	No sensor connected
p0757	CU analog input characteristic value x1
p0758	CU analog input characteristic value y1 [%]
p0759	CU analog input characteristic value x2
p0760	CU analog input characteristic value y2 [%]
p0761	CU analog input wire break monitoring response threshold
p0771	CI: CU analog output signal source, AO 0 (terminals 12, 13) [100 ± 100%]
r0772	CU analog output, output value currently referred
r0774	CU analog output, output voltage/current actual [100% ± p2001]
p0775	CU analog output activate absolute value generation
p0776	CU analog output type
	0   Current output (0 mA ... +20 mA)
	1   Voltage output (0 V... +10 V)
	2   Current output (+4 mA ... +20 mA)

P-No.	Note
p0777	CU analog output characteristic value x1 [%]
p0778	CU analog output characteristic value y1 [V]
p0779	CU analog output characteristic value x2 [%]
p0780	CU analog output characteristic value y2 [V]
p0782	BI: CU analog output invert signal source, AO 0 (terminals 12,13)
r0785	BO: CU analog outputs status word
	.00   1 = AO 0 negative
p0795	CU digital inputs, simulation mode
p0796	CU digital inputs, simulation mode setpoint
p0797	CU analog inputs, simulation mode
p0798	CU analog inputs, simulation mode setpoint
Change over and copy data sets	
p0802	Data transfer with memory card as source/target
p0803	Data transfer with device memory as source/target
p0804	Data transfer start
	12   Start transfer of the GSD for PROFIBUS master on the memory card
p0806	BI: Inhibit master control
r0807	BO: Master control active
p0809	Copy Command Data Set CDS
p0810	BI: Command data set selection CDS bit 0
p0819	Copy drive data set DDS
p0820	BI: Drive data set selection DDS, bit 0
p0826	Motor changeover, motor number
r0835	CO/BO: Data set changeover status word
r0836	CO/BO: Command data set CDS selected
r0837	CO/BO: Drive data set DDS selected
Sequence control (e.g. ON/OFF1)	
p0840	BI: ON/OFF (OFF1)
p0844	BI: No coast down/coast down (OFF2) signal source 1
p0845	BI: No coast down/coast down (OFF2) signal source 2
p0848	BI: No quick stop/quick stop (OFF3) signal source 1
p0849	BI: No quick stop/quick stop (OFF3) signal source 1
p0852	BI: Enable operation
p0854	BI: Master control by PLC
p0855	BI: Unconditionally release holding brake

P-No.	Note
p0856	BI: Enable speed controller
p0858	BI: Unconditionally close holding brake
r0898	CO/BO: Control word sequence control
r0899	CO/BO: Status word sequence control
<b>PROFIBUS, PROFIdrive</b>	
p0918	PROFIBUS address
p0922	PROFIdrive telegram selection
1	Standard telegram 1, PZD-2/2
20	Standard telegram 20, PZD-2/6
352	SIEMENS telegram 352, PZD-6/6:
353	SIEMENS telegram 353, PZD-2/2, PKW-4/4
354	SIEMENS telegram 354, PZD-6/6, PKW-4/4
999	Free telegram configuration with BICO
<b>Faults (Part 1)</b>	
r0944	CO: Counter for fault buffer changes
r0945	Fault code
r0946	Fault code list
r0947	Fault number
r0948	Fault time received in milliseconds [ms]
r0949	Fault value
p0952	Fault cases, counter
r0963	PROFIBUS baud rate
r0964	Device identification
p0965	PROFIdrive profile number
p0969	System runtime relative [ms]
<b>Restoring the factory setting Saving parameters</b>	
p0970	Reset drive parameters
0	Inactive
1	Reset start parameters
5	Starts a safety parameter reset
10	Starts to download setting 10
11	Starts to download setting 11
12	Starts to download setting 12
100	Starts a BICO interconnection reset
p0971	Save parameters
0	Inactive
1	Save drive object

P-No.	Note
10	Save in a non-volatile memory as setting 10
11	Save in a non-volatile memory as setting 11
12	Save in a non-volatile memory as setting 12
p0972	Drive unit reset
<b>Setpoint channel</b>	
p1000	Speed setpoint selection
p1001	CO: Fixed speed setpoint 1 [rpm]
p1002	CO: Fixed speed setpoint 2 [rpm]
p1003	CO: Fixed speed setpoint 3 [rpm]
p1004	CO: Fixed speed setpoint 4 [rpm]
p1005	CO: Fixed speed setpoint 5 [rpm]
p1006	CO: Fixed speed setpoint 6 [rpm]
p1007	CO: Fixed speed setpoint 7 [rpm]
p1008	CO: Fixed speed setpoint 8 [rpm]
p1009	CO: Fixed speed setpoint 9 [rpm]
p1010	CO: Fixed speed setpoint 10 [rpm]
p1011	CO: Fixed speed setpoint 11 [rpm]
p1012	CO: Fixed speed setpoint 12 [rpm]
p1013	CO: Fixed speed setpoint 13 [rpm]
p1014	CO: Fixed speed setpoint 14 [rpm]
p1015	CO: Fixed speed setpoint 15 [rpm]
p1016	Fixed speed setpoint mode
1	Direct selection
2	Selection, binary coded
p1020	BI: Fixed speed setpoint selection bit 0
p1021	BI: Fixed speed setpoint selection bit 1
p1022	BI: Fixed speed setpoint selection bit 2
p1023	BI: Fixed speed setpoint selection bit 3
r1024	CO: Fixed speed setpoint effective [100 % $\pm$ p2000]
r1025	BO: Fixed speed setpoint status
p1030	Motorized potentiometer configuration
00	Storage active
01	Automatic operation, ramp-function generator active
02	Initial rounding active
03	Storage in NVRAM active
p1035	BI: Motorized potentiometer setpoint raise
p1036	BI: Motorized potentiometer setpoint lower

4.2 Further settings

P-No.	Note
p1037	Motorized potentiometer maximum speed [rpm]
p1038	Motorized potentiometer minimum speed [rpm]
p1040	Motorized potentiometer start value [rpm]
p1043	BI: Motorized potentiometer, accept setting value
p1044	CI: Motorized potentiometer setting value [100 % $\pm$ p2000]
r1045	CO: Motorized potentiometer, setpoint in front of the ramp-function generator [rpm]
p1047	Motorized potentiometer ramp-up time [s]
p1048	Motorized potentiometer ramp-down time [s]
r1050	CO: Motorized potentiometer setpoint after the ramp-function generator [100 % $\pm$ p2000]
p1055	BI: Jog bit 0
p1056	BI: Jog bit 1
p1058	Jog 1 speed setpoint [rpm]
p1059	Jog 2 speed setpoint [rpm]
p1070	CI: Main setpoint [100 % $\pm$ p2000]
p1071	CI: Main setpoint scaling [100 $\pm$ 100%]
r1073	CO: Main setpoint effective [100 % $\pm$ p2000]
p1075	CI: Supplementary setpoint [100 % $\pm$ p2000]
p1076	CI: Supplementary setpoint scaling [100 $\pm$ 100%]
r1077	CO: Supplementary setpoint effective [100 % $\pm$ p2000]
r1078	CO: Total setpoint effective [100 % $\pm$ p2000]
p1080	Minimum speed [rpm]
p1082	Maximum speed [rpm]
p1083	CO: Speed limit in positive direction of rotation [rpm]
r1084	CO: Speed limit positive effective [100 % $\pm$ p2000]
p1086	CO: Speed limit in negative direction of rotation [rpm]
r1087	CO: Speed limit negative effective [100 % $\pm$ p2000]
p1091	Skip speed 1 [rpm]
p1092	Skip speed 2 [rpm]
p1101	Skip speed bandwidth [rpm]
p1110	BI: Inhibit negative direction
p1111	BI: Inhibit positive direction
p1113	BI: Setpoint inversion
r1114	CO: Setpoint after the direction limiting [100 % $\pm$ p2000]
r1119	CO: Ramp-function generator setpoint at the input [100 % $\pm$ p2000]

P-No.	Note						
p1120	Ramp-function generator ramp-up time [s]						
p1121	Ramp-function generator ramp-down time [s]						
p1130	Ramp-function generator initial rounding-off time [s]						
p1131	Ramp-function generator final rounding-off time [s]						
p1134	Ramp-function generator rounding-off type						
	<table border="1"> <tr><td>0</td><td>Continuous smoothing</td></tr> <tr><td>1</td><td>Discontinuous smoothing</td></tr> </table>	0	Continuous smoothing	1	Discontinuous smoothing		
0	Continuous smoothing						
1	Discontinuous smoothing						
p1135	OFF3 ramp-down time [s]						
p1136	OFF3 initial rounding-off time [s]						
p1137	OFF3 final rounding-off time [s]						
p1138	CI: Acceleration ramp scaling [100 $\pm$ 100%]						
p1139	CI: Deceleration ramp scaling [100 $\pm$ 100%]						
p1140	BI: Enable ramp-function generator						
p1141	BI: Continue ramp-function generator						
p1142	BI: Enable speed setpoint						
r1149	CO: Ramp-function generator acceleration [100 % $\pm$ p2007]						
r1170	CO: Speed controller setpoint sum [100 % $\pm$ p2000]						
r1198	CO/BO: Control word, setpoint channel						
<b>Functions (e.g. motor holding brake)</b>							
p1200	Flying restart operating mode						
	<table border="1"> <tr><td>0</td><td>Flying restart inactive</td></tr> <tr><td>1</td><td>Flying restart always active (start in setpoint direction)</td></tr> <tr><td>4</td><td>Flying restart always active (start only in setpoint direction)</td></tr> </table>	0	Flying restart inactive	1	Flying restart always active (start in setpoint direction)	4	Flying restart always active (start only in setpoint direction)
0	Flying restart inactive						
1	Flying restart always active (start in setpoint direction)						
4	Flying restart always active (start only in setpoint direction)						
p1201	BI: Flying restart enable signal source						
p1202	Flying restart search current [100 % $\pm$ r0331]						
p1203	Flying restart search rate factor [%]						
	A higher value results in a longer search time.						
p1206	Set fault number without automatic restart						
p1210	Automatic restart mode						

P-No.	Note
	0 Inhibit automatic restart
	1 Acknowledge all faults without restarting
	4 Restart after line supply failure, without additional start attempts
	6 Restart after fault with additional start attempts
	14 Restart after line supply failure following manual acknowledgement
	16 Restart after fault following manual acknowledgement
	26 Acknowledging all faults and restarting for an ON command
p1211	Automatic restart, start attempts
p1212	Automatic restart, delay time start attempts [s]
p1213	Automatic restart, monitoring time [s]
p1215	Motor holding brake configuration
	0 No motor holding brake being used
	3 Motor holding brake like sequential control, connection via BICO
p1216	Motor holding brake, opening time [ms]
p1217	Motor holding brake, closing time [ms]
p1230	BI: DC braking activation
p1231	DC braking configuration
	0 No function
	4 DC braking
	5 DC braking OFF1/OFF3
	14 DC braking below starting speed
p1232	DC braking, braking current [A]
p1233	DC braking time [s]
p1234	Speed at the start of DC braking [rpm]
r1239	CO/BO: DC braking status word
p1240	V <sub>DC</sub> controller or V <sub>DC</sub> monitoring configuration (vector control)
	0 Inhibit V <sub>DC</sub> controller
	1 Enable V <sub>DC,max</sub> controller
	2 Enable V <sub>DC,min</sub> controller (kinetic buffering)
	3 Enable V <sub>DC,min</sub> controller and V <sub>DC,max</sub> controller
r1242	V <sub>DC,max</sub> controller switch-in level [100 % ± p2001]
p1243	V <sub>DC,max</sub> controller dynamic factor [%]
p1245	V <sub>DC,min</sub> controller switch-in level (kinetic buffering) [%]
r1246	V <sub>DC,min</sub> controller switch-in level (kinetic buffering) [100 % ± p2001]

P-No.	Note
p1247	V <sub>DC,min</sub> controller dynamic factor (kinetic buffering) [%]
p1249	V <sub>DC,max</sub> controller speed threshold [rpm]
p1254	V <sub>DC,max</sub> controller automatic ON level detection
	0 Automatic detection inhibited
	1 Automatic detection enabled
p1255	V <sub>DC,min</sub> controller time threshold [s]
p1256	V <sub>DC,min</sub> controller response (kinetic buffering)
	0 Buffer V <sub>DC</sub> until undervoltage, n<p1257 → F07405
	1 Buffer V <sub>DC</sub> until undervoltage, n<p1257 → F07405, t>p1255 → F07406
p1257	V <sub>DC,min</sub> controller speed threshold [rpm]
p1280	V <sub>DC</sub> controller or V <sub>DC</sub> monitoring configuration (V/f)
	0 Inhibit V <sub>DC</sub> controller
	1 Enable V <sub>DC,max</sub> controller
r1282	V <sub>DC,max</sub> controller switch-in level (V/f) [100 % ± p2001]
p1283	V <sub>DC,max</sub> controller dynamic factor (V/f) [%]
V/f control	
p1300	Open-loop/closed-loop control operating mode
	0 V/f control with linear characteristic
	1 V/f control with linear characteristic and FCC
	2 V/f control with parabolic characteristic
	3 V/f control with parameterizable characteristic
	4 V/f control with linear characteristic and ECO
	5 V/f control for drive requiring a precise frequency (e.g. textiles)
	6 V/f control for drive requiring a precise frequency and FCC
	7 V/f control for parabolic characteristic and ECO
	19 V/f control with independent voltage setpoint
	20 Speed control (without encoder)

4.2 Further settings

P-No.	Note
p1310	Voltage boost permanent [100 % ± p0305]
p1311	Voltage boost when accelerating [%]
p1312	Voltage boost when starting [%]
r1315	Voltage boost, total [100 % ± p2001]
p1320	V/f control programmable characteristic frequency 1 [Hz]
p1321	V/f control programmable characteristic voltage 1 [V]
p1322	Characteristic frequency 2 [Hz]
p1323	Characteristic voltage 2 [V]
p1324	Characteristic frequency 3 [Hz]
p1325	Characteristic voltage 3 [V]
p1326	Characteristic frequency 4 [Hz]
p1327	Characteristic voltage 4 [V]
p1330	CI: V/f control independent voltage setpoint [100 % ± p2001]
p1334	V/f control slip compensation starting frequency [Hz]
p1335	Slip compensation, scaling [100 % ± r0330]
p1336	Slip compensation limit value [100 % ± r0330]
r1337	CO: Actual slip compensation [100 ± 100%]
p1338	V/f mode resonance damping gain

P-No.	Note
p1340	I <sub>max</sub> frequency controller proportional gain
p1341	I <sub>max</sub> frequency controller integral time [s]
r1343	CO: I <sub>max</sub> controller frequency output [100 % ± p2000]
p1349	U/f mode resonance damping maximum frequency [Hz]
p1351	CO: Motor holding brake starting frequency [100 ± 100%]
p1352	CI: Motor holding brake starting frequency [100 ± 100%]
<b>Vector control</b>	
r1438	CO: Speed controller speed setpoint [100 % ± p2000]
p1452	Speed controller speed actual value smoothing time (SLVC) [ms]
p1470	Speed controller encoderless operation P gain
p1472	Speed controller sensorless operation integral time [ms]
p1475	CI: Speed controller torque setting value for motor holding brake [100 % ± p2003]
r1482	CO: Speed controller I torque output [100 % ± p2003]
r1493	CO: Moment of inertia, total
p1496	Acceleration pre-control scaling [%]
p1511	CI: Supplementary torque 1 [100 % ± p2003]
r1516	CO: Supplementary torque and acceleration torque [100 % ± p2003]
p1520	CO: Torque limit upper [Nm]
p1521	CO: Torque limit lower [Nm]
p1522	CI: Torque limit upper [100 % ± p2003]
p1523	CI: Torque limit lower [100 % ± p2003]
p1524	CO: Torque limit upper/motoring scaling [100 ± 100%]
p1525	CO: Torque limit lower scaling [100 ± 100%]
r1526	CO: Torque limit upper without offset [100 % ± p2003]
r1527	CO: Torque limit lower without offset [100 % ± p2003]
p1530	Power limit motoring [kW]
p1531	Power limit regenerative [kW]
r1538	CO: Upper effective torque limit [100 % ± p2003]
r1539	CO: Lower effective torque limit [100 % ± p2003]
r1547	CO: Torque limit for speed controller output [0] Upper limit [100 % ± p2003]

P-No.	Note
	[1] Lower limit [100 % $\pm$ p2003]
p1552	CI: Torque limit upper scaling without offset [100 $\pm$ 100%]
p1554	CI: Torque limit lower scaling without offset [100 $\pm$ 100%]
p1570	CO: Flux setpoint [100 $\pm$ 100%]
p1580	Efficiency optimization [%]
r1598	CO: Flux setpoint total [100 $\pm$ 100%]
p1610	Torque setpoint static (SLVC) [100 % $\pm$ r0333]
p1611	Supplementary accelerating torque (SLVC) [100 % $\pm$ r0333]
r1732	CO: Direct-axis voltage setpoint [100 % $\pm$ p2001]
r1733	CO: Quadrature-axis voltage setpoint [100 % $\pm$ p2001]
p1745	Motor model error threshold stall detection [%]
p1784	Motor model feedback scaling [%]
<b>Gating unit</b>	
p1800	Pulse frequency setpoint [kHz]
r1801	CO: Pulse frequency [100 % $\pm$ p2000]
p1820	Reverse the output phase sequence
	0 Off
	1 On
<b>Motor identification</b>	
p1900	Motor data identification and rotating measurement
	0 Inhibited
	1 Identify the motor data at standstill and with the motor rotating
	2 Identify motor data at standstill
	3 Identify motor data with the motor rotating
p1909	Motor data identification control word
p1910	Motor data identification selection
p1959	Rotating measurement configuration
p1960	Rotating measurement selection
	0 Inhibited
	1 Rotating measurement in encoderless operation
	3 Speed controller optimization in encoderless operation
p1961	Saturation characteristic speed to determine [%]
p1965	Speed_ctrl_opt speed [100 % $\pm$ p0310]
p1967	Speed_ctrl_opt dynamic factor [%]

P-No.	Note
<b>Reference values</b>	
p2000	Reference speed reference frequency [rpm]
p2001	Reference voltage [V]
p2002	Reference current [A]
p2003	Reference torque [Nm]
r2004	Reference power
p2006	Reference temperature [°C]
p2010	Commissioning interface baud rate
p2011	Commissioning interface address
p2016	CI: Comm IF USS PZD send word
<b>USS or Modbus RTU</b>	
p2020	Fieldbus interface baud rate:
	4 2400 baud      5 4800 baud
	6 9600 baud      7 19200 baud
	8 38400 baud      9 57600 baud
	10 76800 baud      11 93750 baud
	12 115200 baud      13 187500 baud
p2021	Fieldbus interface address
p2022	Fieldbus interface USS PZD number
p2023	Fieldbus interface USS PKW number
	0 PKW 0 words      3 PKW 3 words
	4 PKW 4 words      127 PKW variable
p2024	Fieldbus interface times [ms]
	[0] Maximum processing time
	[1] Character delay time
	[2] Telegram pause time
r2029	Fieldbus interface error statistics
	[0] Number of error-free telegrams
	[1] Number of rejected telegrams
	[2] Number of framing errors
	[3] Number of overrun errors
	[4] Number of parity errors
	[5] Number of starting character errors
	[6] Number of checksum errors
	[7] Number of length errors
p2030	Fieldbus interface protocol selection
	0 No protocol
	1 USS
	2 MODBUS
	3 PROFIBUS

P-No.	Note
	4 CAN
r2032	Master control, control word effective
	.00 ON / OFF1
	.01 OFF2 inactive
	.02 OFF3 inactive
	.03 Enable operation
	.04 Enable ramp-function generator
	.05 Start ramp-function generator
	.06 Enable speed setpoint
	.07 Acknowledge fault
	.08 Jog bit 0
	.09 Jog bit 1
.10 Master control by PLC	
p2037	PROFIdrive STW1.10 = 0 mode
	0 Freeze setpoints and further process sign-of-life
	1 Freeze setpoints and sign-of-life
p2038	PROFIdrive STW/ZSW interface mode
	0 SINAMICS
	2 VIK-NAMUR
p2040	Fieldbus interface monitoring time [ms]
<b>PROFIBUS, PROFIdrive</b>	
p2042	PROFIBUS ID Number
	0 SINAMICS
	2 VIK-NAMUR
r2043	BO: PROFIdrive PZD state
	.00 Setpoint failure
	.02 Fieldbus operational
p2044	PROFIdrive fault delay [s]
p2047	PROFIBUS additional monitoring time [ms]
r2050	CO: PROFIdrive PZD receive word
	[0] PZD 1 ... [7] PZD 8
p2051	CI: PROFIdrive PZD send word
	[0] PZD 1 ... [7] PZD 8
r2053	PROFIdrive diagnostics send PZD word
	[0] PZD 1 ... [7] PZD 8
r2054	PROFIBUS status
	0 Off
	1 No connection (search for baud rate)
	2 Connection OK (baud rate found)

P-No.	Note
	3 Cyclic connection with master (data exchange)
	4 Cyclic data OK
r2055	PROFIBUS diagnosis standard
	[0] Master bus address
	[1] Master input total length bytes
	[2] Master output total length bytes
r2057	PROFIBUS address switch diagnostics
r2060	CO: IF1 PROFIdrive PZD receive double word
	[0] PZD 1 + 2 ... [10] PZD 11 + 12
r2061	CI: IF1 PROFIdrive PZD send double word
	[0] PZD 1 + 2 ... [10] PZD 11 + 12
r2063	IF1 PROFIdrive diagnostics PZD send double word
	[0] PZD 1 + 2 ... [10] PZD 11 + 12
r2067	IF1 PZD maximum interconnected
	[0] Receiving
	[1] Sending
r2074	PROFIdrive diagnostics bus address PZD receive
	[0] PZD 1 ... [7] PZD 8
r2075	PROFIdrive diagnostics telegram offset PZD receive
	[0] PZD 1 ... [7] PZD 8
r2076	PROFIdrive diagnostics telegram offset PZD send
	[0] PZD 1 ... [7] PZD 8
r2077	PROFIBUS diagnostics peer-to-peer data transfer addresses
p2079	PROFIdrive PZD telegram selection extended See p0922
p2080	BI: Binector-connector converter, status word 1
	The individual bits are combined to form status word 1.
p2088	Binector-connector converter, invert status word
r2089	CO: Send binector-connector converter status word
	[0] Status word 1
	[1] Status word 2
	[2] Free status word 3
	[3] Free status word 4
	[4] Free status word 5
r2090	BO: PROFIdrive PZD1 receive bit-serial
r2091	BO: PROFIdrive PZD2 receive bit-serial
r2092	BO: PROFIdrive PZD3 receive bit-serial

P-No.	Note
r2093	BO: PROFIdrive PZD4 receive bit-serial
r2094	BO: Connector-binector converter binector output
r2095	BO: Connector-binector converter binector output
<b>Faults (Part 2) and alarms</b>	
p2100	Setting the fault number for fault response
p2101	Setting the fault response
	0   None   1   OFF1
	2   OFF2   3   OFF3
	5   STOP2   6   DC braking
p2103	BI: 1. Acknowledge faults
p2104	BI: 2. Acknowledge faults
p2106	BI: External fault 1
r2110	Alarm number
p2111	Alarm counter
p2112	BI: External alarm 1
r2122	Alarm code
r2123	Alarm time received [ms]
r2124	Alarm value
r2125	Alarm time removed [ms]
p2126	Setting fault number for acknowledge mode
p2127	Sets acknowledgement mode
p2128	Selecting fault/alarm code for trigger
r2129	CO/BO: Trigger word for faults and alarms
r2130	Fault time received in days
r2133	Fault value for float values
r2134	Alarm value for float values
r2135	CO/BO: Status word, faults/alarms 2
r2136	Fault time removed in days
r2138	CO/BO: Control word, faults/alarms
r2139	CO/BO: Status word, faults/alarms 1
r2169	CO: Actual speed smoothed signals
r2197	CO/BO: Status word monitoring functions 1
r2198	CO/BO: Status word monitoring 2
r2199	CO/BO: Status word monitoring 3
<b>Technology controller</b>	
p2200	BI: Technology controller enable
p2201	CO: Techn. controller fixed value 1 [100 ± 100%]
p2202	CO: Techn. controller fixed value 2 [100 ± 100%]
p2203	CO: Techn. controller fixed value 3 [100 ± 100%]
p2204	CO: Techn. controller fixed value 4 [100 ± 100%]

P-No.	Note
p2205	CO: Techn. controller fixed value 5 [100 ± 100%]
p2206	CO: Techn. controller fixed value 6 [100 ± 100%]
p2207	CO: Techn. controller fixed value 7 [100 ± 100%]
p2208	CO: Techn. controller fixed value 8 [100 ± 100%]
p2209	CO: Techn. controller fixed value 9 [100 ± 100%]
p2210	CO: Techn. controller fixed value 10 [100 ± 100%]
p2211	CO: Techn. controller fixed value 11 [100 ± 100%]
p2212	CO: Techn. controller fixed value 12 [100 ± 100%]
p2213	CO: Techn. controller fixed value 13 [100 ± 100%]
p2214	CO: Techn. controller fixed value 14 [100 ± 100%]
p2215	CO: Techn. controller fixed value 15 [100 ± 100%]
p2216	Techn. controller fixed value selection method
	0   Fixed value selection direct
	1   Fixed value selection binary
p2220	BI: Techn. controller fixed value selection bit 0
p2221	BI: Techn. controller fixed value selection bit 1
p2222	BI: Techn. controller fixed value selection bit 2
p2223	BI: Techn. controller fixed value selection bit 3
r2224	CO: Techn. controller fixed value active [100 ± 100%]
r2225	CO/BO: Techn. controller fixed value selection status word
r2229	Techn. controller number currently
p2230	Techn. controller motorized potentiometer configuration
	.00   Storage active
	.02   Initial rounding active
	.03   Non-volatile data save active for p2230.0 = 1
	.04   Ramp-function generator always active
r2231	Techn. controller motorized potentiometer setpoint memory
p2235	BI: Techn. controller motorized potentiometer setpoint up
p2236	BI: Techn. controller motorized potentiometer setpoint down
p2237	Techn. controller motorized potentiometer maximum value [%]
p2238	Techn. controller motorized potentiometer minimum value [%]



P-No.	Note	
p3321	Fluid flow machine P = f(n), X coordinate: n flow 1%, point 1	
p3322	P = f(n), Y coordinate: P flow 2%, point 2	
p3323	P = f(n), X coordinate: n flow 2%, point 2	
p3324	P = f(n), Y coordinate: P flow 3%, point 3	
p3325	P = f(n), X coordinate: n flow 3%, point 3	
p3326	P = f(n), Y coordinate: P flow 4%, point 4	
p3327	P = f(n), X coordinate: n flow 4%, point 4	
p3328	P = f(n), Y coordinate: P flow 5%, point 5	
p3329	P = f(n), X coordinate: n flow 5%, point 5	
Two/three wire control		
p3330	BI: 2-3 wire control 1	
p3331	BI: 2-3 wire control 2	
p3332	BI: 2-3 wire control 3	
r3333	CO/BO: 2-3 wire output	
	.00	2-3 wire ON
	.01	2-3 wire reverse
	.02	2-3 wire ON / invert
p3334	2-3 wire selection	
	0	No 2-3 wire control
	1	2-wire forward/backward 1
	2	2-wire forward/backward 2
	3	3-wire enable / forward / backward
p3334	4	3-wire enable / ON / reverse
	Compound braking	
	p3856	Compound braking current [100 ± 100%]
	r3859	CO/BO: Compound braking status word
	Administration parameters	
p3900	Completion of quick commissioning	
r3925	Identification final display	
p3950	Service parameters	
p3981	Faults, acknowledge drive object	
p3985	Master control mode selection	
r3996	Parameter write inhibit status	
r7758	Know-how protection Control Unit serial number	
r7759	Know-how protection Control Unit reference serial number	
p7760	Write protection/know-how protection status	
	.00	1 = Write protection active

P-No.	Note	
	.01	1 = Know-how protection active
	.02	1 = Know-how protection temporarily unlocked
	.03	1 = Know-how protection cannot be deactivated
	.04	1 = Memory card copy protection active
p7761	Write protection	
	0	Deactivate write protection
p7761	1	Activate write protection
	Write access for control using multi-master third-party bus system	
p7762	0	Free write access independent of p7761
	1	No free write access (p7761 is active)
p7763	Know-how protection OEM exception list number of parameters	
p7764	Know-how protection OEM exception list	
p7765	Know-how protection memory card copy protection	
	0	Memory card deactivate copy protection
	1	Memory card activate copy protection
p7766	Know-how protection password input	
p7767	Know-how protection password new	
p7768	Know-how protection password confirmation	
p7769	Know-how protection memory card setpoint serial number	
p7775	NVRAM data action	
r8570	Macro Drive object Display of the macro files stored in the inverter. See also p0015.	
CANopen		
r8600	CAN Device Type	
r8601	CAN Error Register	
p8602	CAN SYNC-Object	
p8603	CAN COB-ID Emergency Message [hex]	
p8604	CAN Node Guarding	
p8606	CAN Producer Heartbeat Time [ms]	
r8607	CAN Identity Object	
p8608	CAN Clear Bus Off Error	
p8609	CAN Error Behavior	
r8610	CAN First Server SDO	
p8611	CAN Pre-defined Error Field [hex]	
p8620	CAN Node-ID	
r8621	CAN Node-ID effective	

P-No.	Note
p8622	CAN bit rate [kBit/s]
	0   1000   1   800   2   500
	3   250   4   125   5   50
	6   20   7   10
p8623	CAN Bit Timing selection [hex]
p8630	CAN virtual objects
p8641	CAN Abort Connection Option Code
	0   No response   1   OFF1
	2   OFF2   3   OFF3
r8680	CAN Diagnosis Hardware
p8684	CAN NMT state after booting
p8685	CAN NMT state
p8699	CAN RPDO monitoring time [ms]
p8700	CAN Receive PDO 1 [hex]
p8701	CAN Receive PDO 2 [hex]
p8702	CAN Receive PDO 3 [hex]
p8703	CAN Receive PDO 4 [hex]
p8704	CAN Receive PDO 5 [hex]
p8705	CAN Receive PDO 6 [hex]
p8706	CAN Receive PDO 7 [hex]
p8707	CAN Receive PDO 8 [hex]
p8710	CAN Receive Mapping for RPDO 1 [hex]
p8711	CAN Receive Mapping for RPDO 2 [hex]
p8712	CAN Receive Mapping for RPDO 3 [hex]
p8713	CAN Receive Mapping for RPDO 4 [hex]
p8714	CAN Receive Mapping for RPDO 5 [hex]
p8715	CAN Receive Mapping for RPDO 6 [hex]
p8716	CAN Receive Mapping for RPDO 7 [hex]
p8717	CAN Receive Mapping for RPDO 8 [hex]
p8720	CAN Transmit PDO 1 [hex]
p8721	CAN Transmit PDO 2 [hex]
p8722	CAN Transmit PDO 3 [hex]
p8723	CAN Transmit PDO 4 [hex]
p8724	CAN Transmit PDO 5 [hex]
p8725	CAN Transmit PDO 6 [hex]
p8726	CAN Transmit PDO 7 [hex]
p8727	CAN Transmit PDO 8 [hex]
p8730	CAN Transmit Mapping for TPDO 1 [hex]
p8731	CAN Transmit Mapping for TPDO 2 [hex]
p8732	CAN Transmit Mapping for TPDO 3 [hex]
p8733	CAN Transmit Mapping for TPDO 4 [hex]
p8734	CAN Transmit Mapping for TPDO 5 [hex]

P-No.	Note
p8735	CAN Transmit Mapping for TPDO 6 [hex]
p8736	CAN Transmit Mapping for TPDO 7 [hex]
p8737	CAN Transmit Mapping for TPDO 8 [hex]
p8741	CAN PDO configuration acknowledgment
p8744	CAN PDO Mapping Configuration
	1:   Predefined connection set
	2:   Free PDO mapping
r8750	CAN mapped receive objects 16 bit
r8751	CAN mapped receive objects 16 bit
r8784	CO: CAN status word
p8785	BI: CAN status word bit 8
p8786	BI: CAN status word bit 14
p8787	BI: CAN status word bit 15
p8790	CAN control word - auto interconnection
r8795	CAN control word
r8797	CAN Target Torque
<b>PROFIdrive</b>	
r8820	Identification and Maintenance 0
p8829	CBE20 Remote Controller number
r8909	PN Device ID
p8920	PN Name of station
p8921	PN IP Address of Station
p8922	PN Default Gateway of Station
p8923	PN Subnet Mask of Station
p8925	PN interfaces configuration
	0:   No function
	1:   Activate the configuration
	2:   Activate the configuration and save
	3:   Delete configuration
p8929	PN Remote Controller number
	0:   Automation or Safety
	1:   Automation and Safety
r8930	PN Name of Station active
r8931	PN IP Address of Station active
r8932	PN Default Gateway of Station active
r8933	PN Subnet Mask of Station active
r8935	PN MAC Address of Station
r8939	PN DAP ID
r8950	CBE20 Name of Station active
r8955	CBE20 MAC Address of Station
r8960	PN Subslot assignment

P-No.	Note
r8961	PN IP Addr Remote Controller 1
r8962	PN IP Addr Remote Controller 2
r8970	CBE20 Subslot assignment
p8991	USB memory access
<b>Parameter consistency and storage</b>	
p9400	Safely remove memory card
	0 No memory card inserted
	1 Memory card inserted
	2 Request "safe removal" of the memory card
	3 "Safe removal" possible
100 "Safe removal" not possible due to access	
r9401	Safely remove memory card status
r9463	Set valid macro
p9484	BICO interconnections, search signal source
r9485	BICO interconnections, search signal source number
r9486	BICO interconnections, search signal source first index
<b>Safety Integrated</b>	
p9601	SI enable, functions integrated in the drive (processor 1)
p9610	SI PROFIsafe address (processor 1)
p9650	SI F-DI changeover, tolerance time (processor 1) [ms]
p9651	SI STO debounce time (processor 1) [ms]
p9659	SI forced checking procedure timer [h]
r9660	SI forced checking procedure remaining time
p9700	SI copy function
p9701	Acknowledge SI data change
p9761	SI password input [hex]
p9762	SI password new [hex]
p9763	SI password acknowledgment [hex]
r9768	SI PROFIsafe control words received (processor 1)
	[0] PZD 1 ... [7] PZD 8
r9769	SI PROFIsafe status words send (processor 1)
	[0] PZD 1 ... [7] PZD 8
r9770	SI version, safety functions integrated in the drive (processor 1)
r9771	SI common functions (processor 1)
r9772	CO/BO: SI status (processor 1)
r9773	CO/BO: SI status (processor 1 + processor 2)

P-No.	Note
r9780	SI monitoring clock cycle (processor 1)
r9781	SI checksum to check changes (processor 1)
r9782	SI time stamp to check changes (processor 1)
r9794	SI crosswise comparison list (processor 1)
r9795	SI diagnostics, STOP F (processor 1)
r9798	SI actual checksum SI parameters (processor 1)
p9799	SI reference checksum SI parameters (processor 1)
p9801	SI enable, functions integrated in the drive (processor 2)
p9810	SI PROFIsafe address (processor 2)
p9850	SI F-DI changeover, tolerance time (processor 2)
p9851	SI STO debounce time (processor 2)
r9871	SI common functions (processor 2)
r9872	CO/BO: SI status (Power Module)
r9898	SI actual checksum SI parameters (processor 2)
p9899	SI reference checksum SI parameters (processor 2)
<b>Diagnostics (internal)</b>	
r9976	System utilization
	[1] Computation time utilization
	[5] Highest gross utilization
r61001	PROFINET IP of Station



## Trouble shooting

### 5.1 List of alarms and faults

Axxxxx Alarm

Fyyyyy: Fault

Table 5- 1 The most important alarms and faults of the safety functions

Number	Cause	Remedy
F01600	STOP A Triggered	STO Select and then deselect again.
F01650	Acceptance test required	Carry out acceptance test and create test certificate. Switch the Control Unit off and then on again.
F01659	Write task for parameter rejected	Cause: The converter should be reset to the factory setting. The resetting of the safety functions is, however, not allowed, because the safety functions are currently enabled.
		Remedy with operator panel:
		p0010 = 30      Parameter reset
		p9761 = ...      Enter password for the safety functions.
		p0970 = 5      Reset Start Safety Parameter. The converter sets p0970 = 5 if it has reset the parameters.
		Then reset the converter to the factory setting again.
A01666	Static 1 signal at F-DI for safe acknowledgment	F-DI to a logical 0 signal.
A01698	Commissioning mode active for safety functions	This message is withdrawn after the Safety commissioning has ended.
A01699	Shutdown path test required	After the next time that the "STO" function is deselected, the message is withdrawn and the monitoring time is reset.
F30600	STOP A Triggered	STO Select and then deselect again.

Table 5- 2 The most important alarms and faults

Number	Cause	Remedy
F01018	Power-up aborted more than once	1. Switch the module off and on again. 2. After this fault has been output, the module is booted with the factory settings. 3. Recommission the converter.
A01028	Configuration error	Explanation: Parameterization on the memory card has been created with a different type of module (order number, MLFB) Check the module parameters and recommission if necessary.
F01033	Unit switchover: Reference parameter value invalid	Set the value of the reference parameter to a value other than 0.0 (p0304, p0305, p0310, p0596, p2000, p2001, p2002, p2003, r2004).

5.1 List of alarms and faults

Number	Cause	Remedy
F01034	Unit switchover: Calculation of the parameter values after reference value change unsuccessful	Select the value of the reference parameter so that the parameters involved can be calculated in the per unit notation (p0304, p0305, p0310, p0596, p2000, p2001, p2002, p2003, r2004).
F01122	Frequency at the probe input too high	Reduce the frequency of the pulses at the probe input.
A01590	Motor maintenance interval lapsed	Carry out the maintenance.
A01900	PROFIBUS: Configuration telegram faulty	Explanation: A PROFIBUS master is attempting to establish a connection with a faulty configuration telegram. Check the bus configuration on the master and slave side.
A01910 F01910	Fieldbus SS setpoint timeout	The alarm is generated when p2040 ≠ 0 ms and one of the following causes is present: <ul style="list-style-type: none"> <li>• The bus connection is interrupted</li> <li>• The MODBUS master is switched off</li> <li>• Communications error (CRC, parity bit, logical error)</li> </ul> An excessively low value for the fieldbus monitoring time (p2040)
A01920	PROFIBUS: Cyclic connection interrupt	Explanation: The cyclic connection to PROFIBUS master is interrupted. Establish the PROFIBUS connection and activate the PROFIBUS master with cyclic operation.
F03505	Analog input, wire break	Check the connection to the signal source for interrupts. Check the level of the signal supplied. The input current measured by the analog input can be read out in r0752.
A03520	Temperature sensor fault	Check that the sensor is connected correctly.
A05000 A05001 A05002 A05004 A05006	Power Module overtemperature	Check the following: <ul style="list-style-type: none"> <li>- Is the ambient temperature within the defined limit values?</li> <li>- Are the load conditions and duty cycle configured accordingly?</li> <li>- Has the cooling failed?</li> </ul>
F06310	Supply voltage (p0210) incorrectly parameterized	Check the parameterized supply voltage and if required change (p0210). Check the line voltage.
F07011	Motor overtemperature	Reduce the motor load. Check ambient temperature. Check sensor's wiring and connection.
A07012	I2t Motor Module overtemperature	Check and if necessary reduce the motor load. Check the motor's ambient temperature. Check thermal time constant p0611. Check overtemperature fault threshold p0605.
A07015	Motor temperature sensor alarm	Check that the sensor is connected correctly. Check the parameter assignment (p0601).
F07016	Motor temperature sensor fault	Make sure that the sensor is connected correctly. Check the parameterization (p0601).
F07086 F07088	Unit switchover: Parameter limit violation	Check the adapted parameter values and if required correct.

Number	Cause	Remedy
F07320	Automatic restart aborted	Increase the number of restart attempts (p1211). The current number of start attempts is shown in r1214. Increase the wait time in p1212 and/or monitoring time in p1213. Create ON command (p0840). Increase the monitoring time of the power unit or switch off (p0857). Reduce the wait time for resetting the fault counter p1213[1] so that fewer faults are registered in the time interval.
A07321	Automatic restart active	Explanation: The automatic restart (AR) is active. During voltage recovery and/or when remedying the causes of pending faults, the drive is automatically switched back on.
F07330	Search current measured too low	Increase search current (P1202), check motor connection.
A07400	V <sub>DC_max</sub> controller active	If the controller is not to intervene: <ul style="list-style-type: none"> <li>• Increase the ramp-down times.</li> <li>• Deactivate the V<sub>DC_max</sub> controller (p1240 = 0 for vector control, p1280 = 0 for V/f control).</li> </ul>
A07409	V/f control current limiting controller active	The alarm automatically disappears after one of the following measures: <ul style="list-style-type: none"> <li>• Increase the current limit (p0640).</li> <li>• Reduce load.</li> <li>• Increase the ramp-up time to the speed setpoint.</li> </ul>
F07426	Technology controller actual value limited	<ul style="list-style-type: none"> <li>• Adapt the limits to the signal level (p2267, p2268).</li> <li>• Check the actual value scaling (p2264).</li> </ul>
F07801	Motor overcurrent	Check current limits (p0640). U/f control: Check the current limiting controller (p1340 ... p1346). Increase acceleration ramp (p1120) or reduce load. Check motor and motor cables for short circuit and ground fault. Check motor for star-delta connection and rating plate parameterization. Check power unit / motor combination. Select flying restart function (p1200) if switched to rotating motor.
A07805	Drive: Power unit overload I2t	<ul style="list-style-type: none"> <li>• Reduce the continuous load.</li> <li>• Adapt the load cycle.</li> <li>• Check the assignment of rated currents of the motor and power unit.</li> </ul>
F07807	Short circuit detected	<ul style="list-style-type: none"> <li>• Check the converter connection on the motor side for any phase-phase short-circuit.</li> <li>• Rule out that line and motor cables have been interchanged.</li> </ul>
A07850	External alarm 1	The signal for "external alarm 1" has been triggered. Parameter p2112 defines the signal source of the external alarm. Remedy: Rectify the cause of this alarm.
F07860	External fault 1	Remove the external causes for this fault.
F07900	Motor blocked	<ul style="list-style-type: none"> <li>• Make sure that the motor can rotate freely.</li> <li>• Check the torque limit: r1538 for a positive direction of rotation; r1539 for a negative direction of rotation.</li> </ul>

5.1 List of alarms and faults

Number	Cause	Remedy
F07901	Motor overspeed	Activate precontrol of the speed limiting controller (p1401 bit 7 = 1).
F07902	Motor stalled	Check whether the motor data has been parameterized correctly and perform motor identification. Check the current limits (p0640, r0067, r0289). If the current limits are too low, the drive cannot be magnetized. Check whether motor cables are disconnected during operation.
A07903	Motor speed deviation	Increase p2163 and/or p2166. Increase the torque, current and power limits.
A07910	Motor overtemperature	Check the motor load. Check the motor's ambient temperature. Check the KTY84 sensor.
A07920	Torque/speed too low	The torque deviates from the torque/speed envelope curve. <ul style="list-style-type: none"> <li>• Check the connection between the motor and the load.</li> <li>• Adapt the parameterization corresponding to the load.</li> </ul>
A07921	Torque/speed too high	
A07922	Torque/speed out of tolerance	
F07923	Torque/speed too low	<ul style="list-style-type: none"> <li>• Check the connection between the motor and the load.</li> <li>• Adapt the parameterization corresponding to the load.</li> </ul>
F07924	Torque/speed too high	
A07927	DC braking active	Not required
A07980	Rotary measurement activated	Not required
A07981	No enabling for rotary measurement	Acknowledge pending faults. Establish missing enables (see r00002, r0046).
A07991	Motor data identification activated	Switch on the motor and identify the motor data.
F08501	Setpoint timeout	<ul style="list-style-type: none"> <li>• Check the PROFINET connection.</li> <li>• Set the controller to RUN mode.</li> <li>• If the error occurs repeatedly, check the monitoring time set (p2044).</li> </ul>
F08502	Monitoring time, sign-of-life expired	<ul style="list-style-type: none"> <li>• Check the PROFINET connection.</li> </ul>
F08510	Send configuration data not valid	<ul style="list-style-type: none"> <li>• Check the PROFINET configuration</li> </ul>
A08511	Receive configuration data not valid	
A08526	No cyclic connection	<ul style="list-style-type: none"> <li>• Activate the controller with cyclic operation.</li> <li>• Check the parameters "Name of Station" and "IP of Station" (r61000, r61001).</li> </ul>
A08565	Consistency error affecting adjustable parameters	Check the following: <ul style="list-style-type: none"> <li>• IP address, subnet mask or default gateway is not correct.</li> <li>• IP address or station name used twice in the network.</li> <li>• Station name contains invalid characters.</li> </ul>

Number	Cause	Remedy
F08700	Communications error	<p>A CAN communications error has occurred. Check the following:</p> <ul style="list-style-type: none"> <li>• Bus cable</li> <li>• Baud rate (p8622)</li> <li>• Bit timing (p8623)</li> <li>• Master</li> </ul> <p>Start the CAN controller manually with p8608 = 1 after the cause of the fault has been resolved!</p>
F13100	Know-how protection: Copy protection error	<p>The know-how protection and the copy protection for the memory card are active. An error occurred during checking of the memory card.</p> <ul style="list-style-type: none"> <li>• Insert a suitable memory card and switch the converter supply voltage temporarily off and then on again (POWER ON).</li> <li>• Deactivate the copy protection (p7765).</li> </ul>
F13101	Know-how protection: Copy protection cannot be activated	Insert a valid memory card.
F30001	Overcurrent	<p>Check the following:</p> <ul style="list-style-type: none"> <li>• Motor data, if required, carry out commissioning</li> <li>• Motor's connection method (Y / Δ)</li> <li>• U/f operation: Assignment of rated currents of motor and Power Module</li> <li>• Line quality</li> <li>• Make sure that the line commutating reactor is connected properly</li> <li>• Power cable connections</li> <li>• Power cables for short-circuit or ground fault</li> <li>• Power cable length</li> <li>• Line phases</li> </ul> <p>If this doesn't help:</p> <ul style="list-style-type: none"> <li>• U/f operation: Increase the acceleration ramp</li> <li>• Reduce the load</li> <li>• Replace the power unit</li> </ul>
F30002	DC-link voltage overvoltage	<p>Increase the ramp-down time (p1121). Set the rounding times (p1130, p1136). Activate the DC link voltage controller (p1240, p1280). Check the line voltage (p0210). Check the line phases.</p>
F30003	DC-link voltage undervoltage	Check the line voltage (p0210).
F30004	Converter overtemperature	<p>Check whether the converter fan is running. Check whether the ambient temperature is in the permissible range. Check whether the motor is overloaded. Reduce the pulse frequency.</p>
F30005	I <sub>2t</sub> converter overload	<p>Check the rated currents of the motor and Power Module. Reduce current limit p0640. When operating with U/f characteristic: Reduce p1341.</p>

5.1 List of alarms and faults

Number	Cause	Remedy
F30011	Line phase failure	Check the converter's input fuses. Check the motor cables.
F30015	Motor cable phase failure	Check the motor cables. Increase the ramp-up or ramp-down time (p1120).
F30021	Ground fault	<ul style="list-style-type: none"> <li>• Check the power cable connections.</li> <li>• Check the motor.</li> <li>• Check the current transformer.</li> <li>• Check the cables and contacts of the brake connection (a wire might be broken).</li> </ul>
F30027	Time monitoring for DC link pre-charging	Check the supply voltage on the input terminals. Check the line voltage setting (p0210).
F30035	Overtemperature, intake air	<ul style="list-style-type: none"> <li>• Check whether the fan is running.</li> <li>• Check the fan filter elements.</li> <li>• Check whether the ambient temperature is in the permissible range.</li> </ul>
F30036	Overtemperature, inside area	
F30037	Rectifier overtemperature	See F30035 and, in addition: <ul style="list-style-type: none"> <li>• Check the motor load.</li> <li>• Check the line phases</li> </ul>
A30049	Internal fan defective	Check the internal fan and if required replace.
F30059	Internal fan defective	Check the internal fan and if required replace.
F30074	Communications fault between Control Unit and Power Module	The 24V voltage supply of the converter (terminals 31 and 32) was interrupted briefly. Please check the voltage supply and the wiring.
A30502	DC link overvoltage	<ul style="list-style-type: none"> <li>• Check the device supply voltage (p0210).</li> <li>• Check the line reactor dimensioning</li> </ul>
A30920	Temperature sensor fault	Check that the sensor is connected correctly.
A50001	PROFINET configuration error	A PROFINET controller is attempting to establish a connection with a faulty configuration telegram. Check to see whether "Shared Device" is activated (p8929 = 2).
A50010	PROFINET name of station invalid	Correct name of station (p8920) and activate (p8925 = 2).
A50020	PROFINET: Second controller missing	"Shared Device" is activated (p8929 = 2). However, only the connection to a PROFINET controller is present.

For further information, please refer to the List Manual.

## 5.2 Product support

Table 5- 3 Technical Support

France	Germany	Italy	Spain	United Kingdom
+33 (0) 821 801 122	+49 (0)911 895 7222	+39 (02) 24362000	+34 902 237 238	+44 161 446 5545
Further service telephone numbers: Product support ( <a href="http://support.automation.siemens.com/WW/view/en/4000024">http://support.automation.siemens.com/WW/view/en/4000024</a> )				

Table 5- 4 Manuals with further information

Information level	Manual	Content	Available languages	Download or order number
+	Getting Started	(this manual)	English, German, Italian, French, Spanish, Chinese	Documentation download ( <a href="http://support.automation.siemens.com/WW/view/en/36426537/133300">http://support.automation.siemens.com/WW/view/en/36426537/133300</a> ) SINAMICS Manual Collection Documentation on DVD Order number: 6SL3097-4CA00-0YG0
++	Operating instructions - converter	Installing, commissioning and operating the converter. Description of converter functions. Technical data.		
+++	Function Manual Safety Integrated	Configuring PROFIsafe. Installing, commissioning and operating the integrated fail-safe function.	English, German	
+++	List manual	Complete list of parameters, alarms and faults. Graphic function block diagrams.	English, German, Chinese	
+++	Operating instructions - BOP-2, IOP	Description of operator panel	English, German	

## 5.3 Spare parts

		Order number
Spare part kit including 5 sets I/O terminals, 2 door sets and 1 blind cover		6SL3200-0SK41-0AA0
Screening plates	Frame size A	6SL3266-1EA00-0KA0
	Frame size B	6SL3266-1EB00-0KA0
	Frame size C	6SL3266-1EC00-0KA0
1 set of connector plugs (mains, motor and breaking resistor)	Frame size A	6SL3200-0ST05-0AA0
	Frame size B	6SL3200-0ST06-0AA0
	Frame size C	6SL3200-0ST07-0AA0
Fan units	Frame size A	6SL3200-0SF12-0AA0
	Frame size B	6SL3200-0SF13-0AA0
	Frame size C	6SL3200-0SF14-0AA0
Top cover with built in fan	Frame size A	6SL3200-0SF40-0AA0
	Frame size B	6SL3200-0SF41-0AA0
	Frame size C	6SL3200-0SF42-0AA0





Siemens AG  
Industry Sector  
Drive Technologies  
Motion Control Systems  
P.O. Box 3180  
91050 ERLANGEN  
GERMANY

[www.siemens.com/sinamics-g120](http://www.siemens.com/sinamics-g120)

We reserve the right to make technical changes.  
© Siemens AG 2012