

# *Brake Chopper*

## ***BC 2.1 - BC 4.1***

### Instruction and Operation Manual

Start at serial number: 11001



#### **CP Automation Ltd**

General Enquiries: 01724 851515

Enquiries: [sales@cpaltd.net](mailto:sales@cpaltd.net)

Web: [www.cpa-ltd.net](http://www.cpa-ltd.net)

Address: Unit 8 Ashley Industrial Estate, Exmoor Avenue, Scunthorpe. DN15 8NJ

REV: CPA-BC-MANUAL-V2.0-2020-JMR01



## Table of contents

1.	Instruction of Safety .....	3
1.1	Instructions and Rules .....	3
1.2	Safety.....	3
2.	Function .....	4
3.	Example of Connection .....	4
4.	Mounting and Location .....	5
5.	Technical Data.....	6
5.1	Chopper voltage 375V .....	6
5.2	Chopper voltage 750V .....	6
5.3	Chopper voltage 980V .....	6
6.	General data .....	7
7.	Load Curve .....	7
8.	Connections and Indications.....	8
9.	Dimensions .....	8
10.	Options and Protection .....	9
10.1	Overcurrent relay.....	9
10.2	DC Bus Ultrafast semiconductor fuse kit.....	9
11.	Calculation Braking Chopper and Resistor .....	9 & 10
12.	Connection Diagramm options, ready for operation & Chopper active .....	11
13.	Connection Diagramm option Master – Slave.....	12

## 1. Instruction of Safety



*Before you put the chopper into operation, please read this instruction and operation manual completely.*

*The operation should only be done by qualified personnel.*

*The precautions and warnings below must be observed at the operation of the chopper. The braking chopper instruction and operation manual do not replace the manual of initial operation of the inverter.*

### 1.1 Instructions and Rules

During installation, general installation regulations such as following should be observed

<b>DIN VDE 0100</b>	General requirements for the installation of power with mains
<b>VDE 0113</b>	General requirements for the installation of electrical equipment for production and tooling machines
<b>VDE 0160</b>	Requirements for electronic equipment for use in electrical power installations
<b>VDE 0470 Part 1</b>	International protection

### 1.2 Safety



#### **Caution Danger !**

Disconnect unit from mains and wait until the capacitors have discharged before making any repairs. After the installation make sure that the unit and motor is properly grounded in order to avoid electrical hazard.



As with any form of electrical equipment, there is always a risk involved in the handling of electrical machinery. The greatest care must always be exercised during installation and maintenance. It is recommended that service is performed by authorized personnel only



#### **Caution !**

1. Do not connect or disconnect the chopper when it has power.
2. Please take care of the correct polarity.
3. If you exchange the connections BUSS + and BUSS- the inverter or the chopper can be destroyed.
4. An ultra rapid fuse for the protection of the IGBT is not installed.

## 2. Function

If the speed of the motor is reduced the motor behaves like a generator. Since the kinetical energy is not sent back with the Inverter to mains the intermediate circuit (BUSS) capacitors store the energy. The voltage of the intermediate circuit increases. If the intermediate circuit voltage the inverter protects itself by turning off.

To avoid the interruption of braking, a Braking Choppers is used. It is activated if the voltage of the intermediate circuit is higher than the tolerable intermediate circuit voltage. The braking resistor is connected with the intermediate circuit and the additional energy is transformed to heat. If big masses have to be decelerated the braking resistor must have enough power related to the kinetical energy.

## 3. Example of Connection

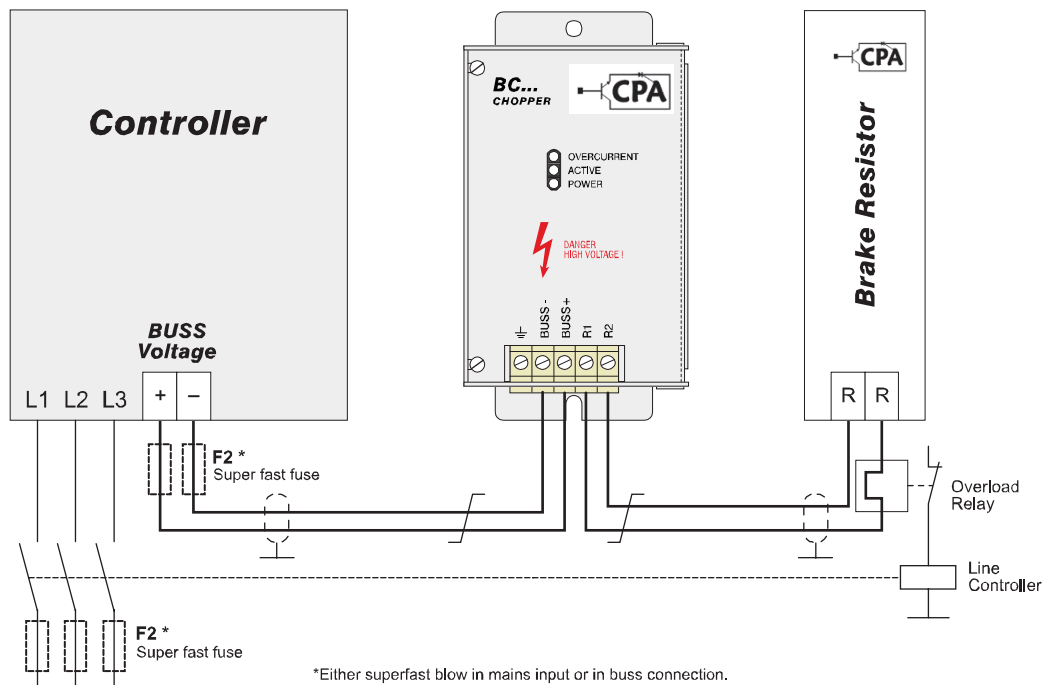

If cables between inverter and chopper resp. chopper and brake resistor are less than 25 cm, they have to be twisted and if they are longer than 25 cm they have to be shielded

## 4. Mounting and Location

### BC 2.1

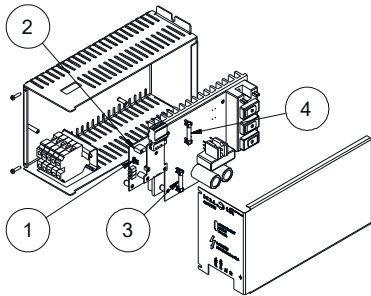

### BC 3.1

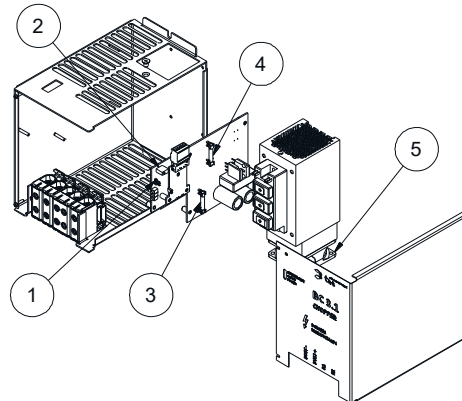

### BC 4.1

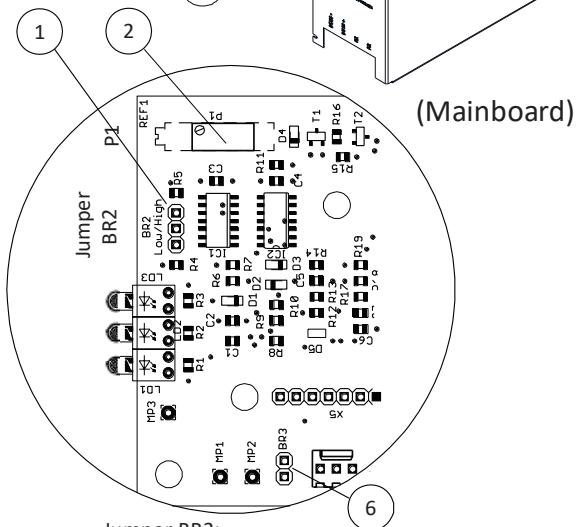
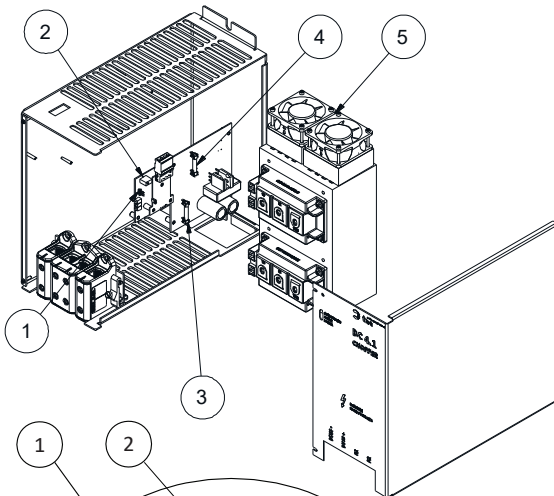

- 6 Jumper BR3:  
 without Master/Slave-Option connected    
 at Master/Slave-Option not connected

	Connection Voltage		
	BR2	200 - 440V	450 - 800V
1 Chopper voltage at potentiometer P1 at factory adjustment	High	<input type="checkbox"/> <input type="checkbox"/>	375V 750V
	Low	<input type="checkbox"/> <input type="checkbox"/>	340V 680V

Type	Position					
	1	2	3	4	5	6
BC 2.1-16/5,5	Jumper BR2	Potentiometer P1	Fuse F1 (only electronic not IGBT)	Fuse F2 (only electronic not IGBT)	1x Fan	Jumper BR3
BC 2.1-24/6						
BC 2.1-33/11						
BC 2.1-51/13						
BC 3.1-32/13						
BC 3.1-32/22						
BC 3.1-47/25						
BC 3.1-65/27						
BC 3.1-67/26						
BC 3.1-67/45						
BC 3.1-97/52	1x Fan					
BC 3.1-135/56	2x Fan					
BC 4.1-90/33						
BC 4.1-120/36						
BC 4.1-180/67						
BC 4.1-185/41						
BC 4.1-250/75						
BC 4.1-375/82						

## 5. Technical Data:

### 5.1 Chopper voltage 375V

Connection voltage		200 - 440 VDC		BUSS +/-		
Chopper voltage		Factory adjustment Jumper BR2 right:375V, BR2 left: 340V Control range potentiometer P1: 240 to 440, turn clockwise to increase 10V/turn				
Part No	Brake power in kVA at		Permanent current [in A]	Peak current [in A]	Superfast fuse F2 [in A]	Brake resistor $>R_{min}$
	Permanent load	Peak load				
CPA-BC 2.1-16/5,5	5,5	16	15	45	50	8Ω
CPA-BC 2.1-24/6	6	24	17	68	63	5,3Ω
CPA-BC 3.1-32/13	13	32	35	90	100	4Ω
CPA-BC 3.1-32/22	22	32	60	90	100	4Ω
CPA-BC 3.1-47/25	25	47	70	130	125	2,8Ω
CPA-BC 3.1-65/27	27	65	75	180	200	2Ω
CPA-BC 4.1-90/33	33	90	90	240	250	1,6Ω
CPA-BC 4.1-120/36	36	120	100	330	355	1,1Ω
CPA-BC 4.1-185/41	41	185	110	500	500	0,75Ω

### 5.2 Chopper voltage 750V

Connection voltage		450 - 800 VDC		BUSS +/-		
Chopper voltage		Factory adjustment Jumper BR2 right:750V, BR2 left: 680V Control range potentiometer P1: 540 to 800, turn clockwise to increase 25V/turn				
Part No	Brake power in kVA at		Permanent current [in A]	Peak current [in A]	Superfast fuse F2 [in A]	Brake resistor $>R_{min}$
	Permanent load	Peak load				
CPA-BC 2.1-33/11	11	33	15	45	50	16Ω
CPA-BC 2.1-51/13	13	51	17	68	63	11Ω
CPA-BC 3.1-67/26	26	67	35	90	100	8,5Ω
CPA-BC 3.1-67/45	45	67	60	90	100	8,5Ω
CPA-BC 3.1-97/52	52	97	70	130	125	5,5Ω
CPA-BC 3.1-135/56	56	135	75	180	200	4,2Ω
CPA-BC 4.1-180/67	67	180	90	240	250	3,2Ω
CPA-BC 4.1-250/75	75	250	100	330	355	2,3Ω
CPA-BC 4.1-360/100	100	360	133	480	500	1,5Ω

### 5.3 Chopper voltage 980VDC

810 - 980 VDC		BUSS +/-				
Factory adjustment Jumper BR2 right: 980V, BR2 left: 905V Control range potentiometer P1: 940 to 1020, cw: 25V/turn lower						
Part Number	Brake power in kVA at		Continuous current [in A]	Peak current [in A]	Superfast fuse F2 [in A]	Brake resistor $>R_{min}$
	Continuous load	Peak load				
CPA-BC 3.2-80/31	31	80	35	85	100	12Ω
CPA-BC 3.2-80/54	54	80	58	85	100	12Ω
CPA-BC 3.2-116/62	62	116	66	125	125	7.9Ω
CPA-BC3.2-162/67	67	162	72	170	200	5.8Ω
CPA-BC3.2-216/80	80	216	85	210	250	4.7Ω
CPA-BC 4.2-300/90	90	300	95	315	350	3.2Ω
CPA-BC 4.2-432/101	101	432	105	400	400	2.5Ω
CPA-BC 4.2-600/180	180	600	190	630	630	1.6Ω

*Chopper Voltages 1000V-1200V available on request*



*The brake resistor  $\Omega$  has to be  $\geq$  than  $R_{min}$ . If the brake resistor  $\Omega$  is lower than  $R_{min}$ , the BC UNIT's IGBT can be destroyed. The output is protected against short circuit, but not against permanent overload.*

## 6. General Data

Range	Values
Permissible temperature range	During transport of the unit: -25°C...+70°C (to VDE 0160) During storage of the unit: -25°C...+55°C (to VDE 0160) During operation of the unit: 5°C...+40°C (without power derating) 40°C...+55°C (with power derating)
Humidity class	Humidity class F without condensation (5% - 85% relative humidity)
Environment: Resonances each	Base standard: DIN EN 60068-2-6 Test specification: (5 Hz-13,2 Hz)-150 Hz, 2mm peak to peak 0,7g
Installation height h:	H ≤ 1000 m a.m.s.l. without power derating 1000 m a.m.s.l. < h 4000 m a.m.s.l. with power derating
Air pressure	86kPa – 106kPa to VDE0875 part 11 and prEN55082
Degree of pollution	VDE 0110 Part 2 degree 2
Enclosure:	IP20

## 7. Load Curve

at 40°C ambient temperature

### LOAD CURVE

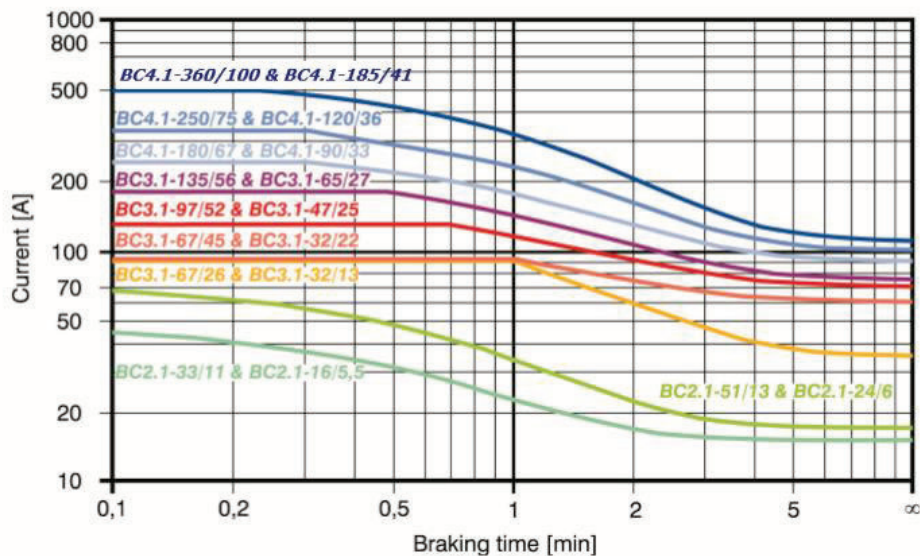

## 8. Connections and Indications

### Indications

Overcurrent	red	Overcurrent/Short circuit
Active	clear	Chopper is active
Power	green	Chopper is ready

### Connections of the terminal blocks



Grounding: Large-area earthing of the cover is recommended, e.g. mounting on a galvanized assembly plate.

BUSS-	-connection BUSS-voltage inverter
BUSS+	+connection BUSS-voltage inverter
R1 - R2	a thermo protection has to be connected in row to the brake resistor. This thermo protection has to be adjusted to the nominal current of the brake resistor. (see Chapter 7 Example of Connection)

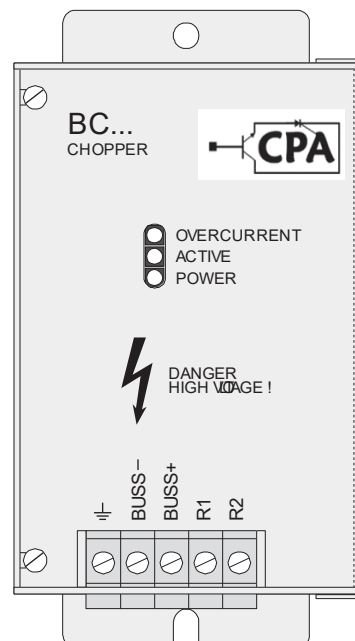

### Caution !



1. Do not connect or disconnect the chopper when it has power.
2. Please take care of the correct polarity.
3. If you exchange the connections BUSS + and BUSS- the inverter or the chopper can be destroyed.
4. An ultra rapid fuse for the protection of the IGBT is not installed.

## 9. Dimensions

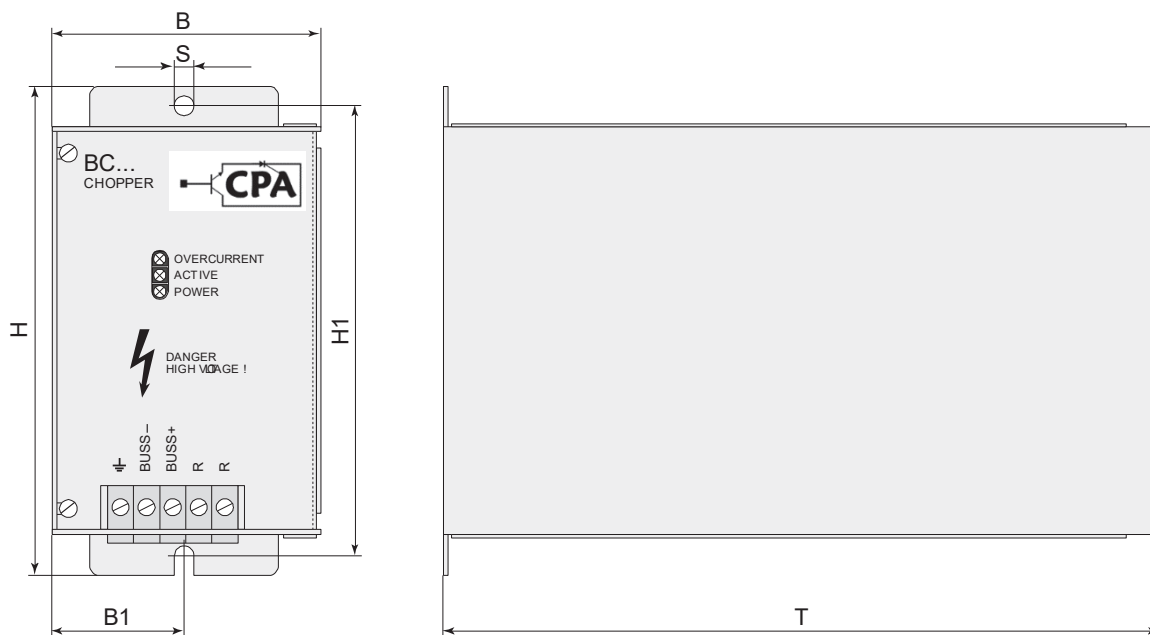

### Dimensions in mm

Device size	B	B1	H	H1	T	S
BC 2.1	82,5	40,5	150	138	220	6
BC 3.1	130	64,5	205	193	208	6
BC 4.1	131	64,5	298	280	300	9

## 10. Options & Protection

- Brake resistors from 100W to MW's, continuously rated, IP 20-IP65, air cooled to Liquid cooled.
- Overcurrent relays for protection of the brake resistor against thermal overstressing.
- Factory Fitted Options (must be added at order point cannot be fitted retrospectively)  
Fault Output Card "-RM" (See section 11) and Master/Slave Card "-MS" (See section 12)

### 10.1 Over current relay

Part Number	Adjustment Range in Amps	
	CPA-FPS1.6	1.0
CPA-FPS2.5	1.6	2.5
CPA-FPS4	2.5	4
CPA-FPS6.3	4	6.3
CPA-FPS10	6.3	10
CPA-FPS16	10	16
CPA-FPS20	16	20
CPA-FPS25	20	25
CPA-FPS32	25	32
CPA-FPS40	32	40



### 10.2 DC Bus Ultrafast semiconductor fuse kit

Brake Chopper	Fuse Kit	Description	Fuse Rating
CPABC2.1-33/11	CPA-FK33	2 DC Bus Fuses & Fuse Holder	50
CPABC2.1-51/13	CPA-FK51	2 DC Bus Fuses & Fuse Holder	63
CPABC3.1-67/26 & 45	CPA-FK67	2 DC Bus Fuses & Fuse Holder	100
CPABC3.1-97/52	CPA-FK97	2 DC Bus Fuses & Fuse Holder	125
CPABC3.1-135/56	CPA-FK135	2 DC Bus Fuses & Fuse Holder	200
CPABC4.1-180/67	CPA-FK180	2 DC Bus Fuses & Fuse Holder	250
CPABC4.1-250/75	CPA-FK250	2 DC Bus Fuses & Fuse Holder	350
CPABC4.1-360/100	CPA-FK360	2 DC Bus Fuses & Fuse Holder	500

## 11. Calculation Braking Chopper and Resistor

Basis of calculation:

Constant Brake torque and linear speed reduction

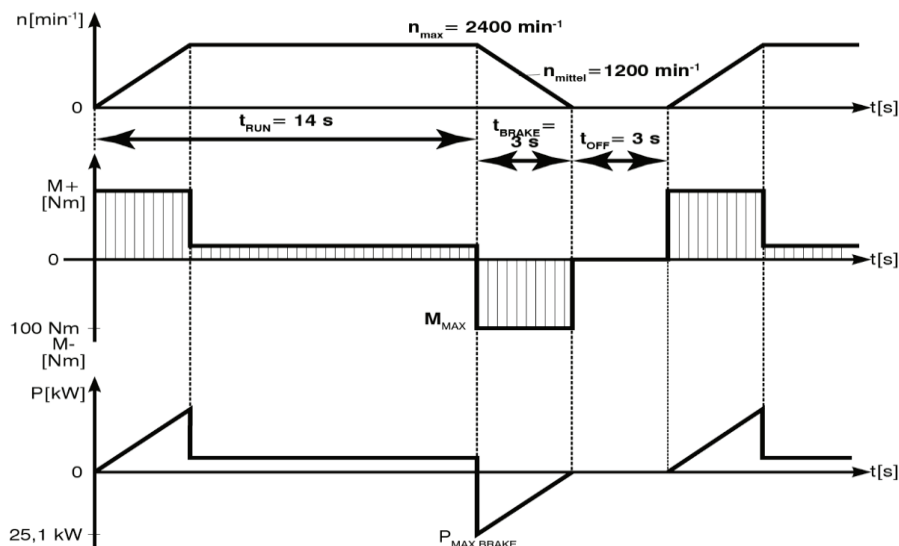

**Example:** Chopper voltage 750 V

Brake torque 100 Nm

Max Speed 2400 min<sup>-1</sup>

Motor operation time 14 sec.

Brake time 3 sec.

Stop 3 sec.

### Calculation Peak Load $P_{MAX\ BRAKE}$

$$P_{MAX\ BRAKE} = \frac{n_{MAX} \times M_{MAX}}{9550} = \frac{2400 \times 100}{9550} = 25,1\text{ kW}$$

$P_{MAX\ BRAKE}$	in [kW]	peak load brake chopper
$n_{MAX}$	in [ $\text{min}^{-1}$ ]	max speed
$M_{MAX}$	in [Nm]	max brake torque

### Calculation RMS Brake load $P_{BRAKE\ RMS}$

$$P_{BRAKE\ RMS} = P_{MAX\ BRAKE} \times \sqrt{\frac{t_{BRAKE}}{3 \times (t_{RUN} + t_{BRAKE} + t_{OFF})}} = 25,1 \times \sqrt{\frac{3}{3 \times (14 + 3 + 3)}} = 5,6\text{ kW}$$

$P_{BRAKE\ RMS}$	in [kW]	RMS brake load
$P_{MAX\ BRAKE}$	in [kW]	peak load brake chopper
$t_{BRAKE}$	in [seconds]	brake time
$t_{RUN}$	in [seconds]	motoring operation
$t_{BRAKE}$	in [seconds]	regen operation
$t_{OFF}$	in [seconds]	stop

### Calculation Brake Resistor

$$R = \frac{U^2}{P_{MAX\ BRAKE}} = \frac{750^2}{25100} = 22,4\ \Omega$$

$R$	in [ $\Omega$ ]	brake resistor
$U$	in [V]	(turn-on) voltage
$P_{MAX\ BRAKE}$	in [W]	peak load brake chopper

### Brake Chopper selected from table 4.2 (refer to technical data)

Brake chopper BC2.1-33/11 Art.-No. 12262-0F00

Chopper voltage 750V

#### Permanent Load:

$$P_{BRAKE\ RMS} = \underline{5,6 < 11\text{ kW}} \quad \text{OK}$$

#### Peak Load:

$$P_{MAX\ BRAKE} = \underline{25,1 < 33\text{ kW}} \quad \text{OK}$$

#### Brake Resistor:

$$R = \underline{22,4 > 16\ \Omega} \quad \text{OK}$$

## 12. Connection Diagram “-RM” option, Ready & Chopper Active

### C2/A2 Stör- und Betriebsbereitmeldung (Potentialfreier Kontakt)

Chopper Betriebsbereit, kein Fehler C2/A2 geschlossen  
Chopper nicht Betriebsbereit oder Fehler C2/A2 offen

### C1/A1 Chopper Aktiv, verzögert Aus (Potentialfreier Kontakt)

Chopper Aktive C1/A1 Ausgangslogik konfigurierbar über Dipschalter S1, siehe Tabelle unten

**BR1** Verbindet C1 mit C2

### C2/A2 message "error" and "ready for operation" (potential-free contact)

Chopper ready, no fault C2/A2 closed  
Chopper not ready or fault C2/A2 open

### C1/A1 Chopper active, delayed OFF (potential-free contact)

Chopper active C1/A1 logical output configurable with dip-switch S1, refer to table below

**BR1** Connects C1 with C2

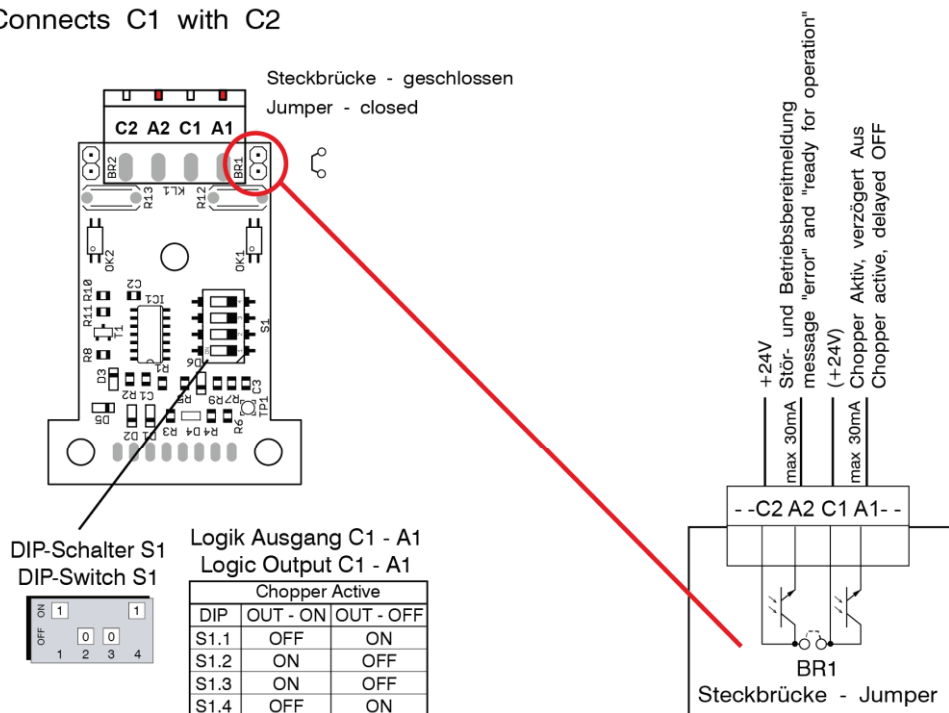

### 13. Connection Diagram "MS" option, Master – Slave



**Achtung !!! Anschlüsse O,G,I,C führen 400VDC nach Erde!**  
**Caution !!! Connection O,G,I,C lead 400VDC to ground!**

**Anschluss Variante 1: Master - Slave (in Reihe) - Connection version 1: Master - Slave (in series)**

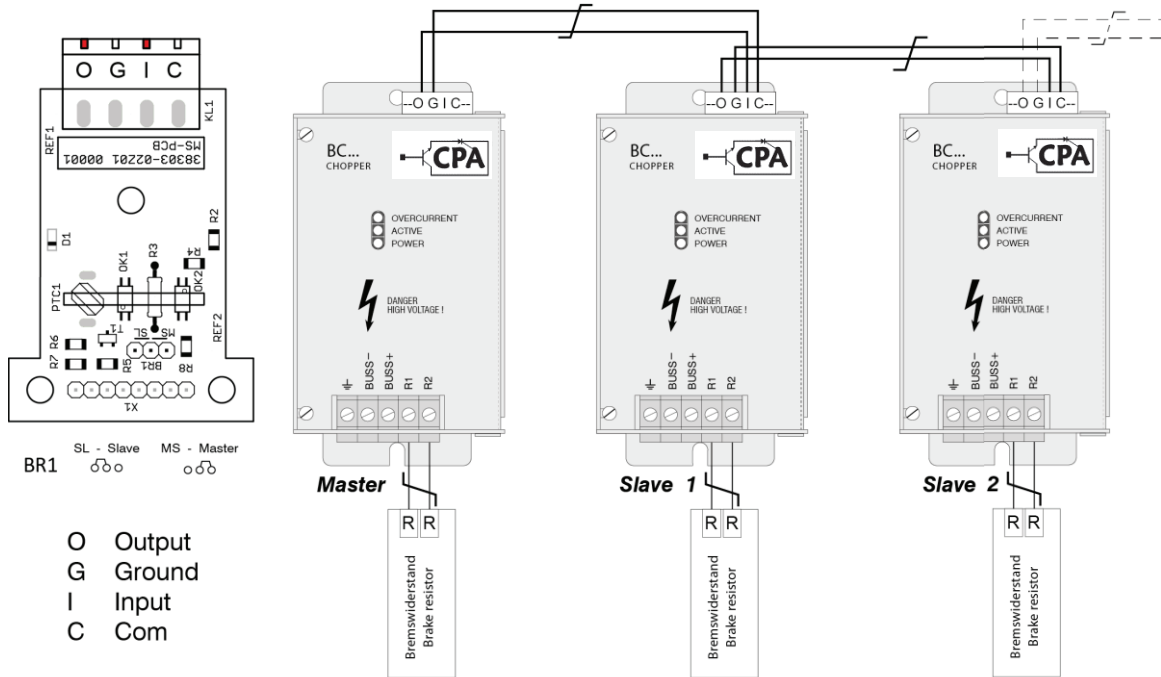

**Anschluss Variante 2: Master - Slave (Parallel) - Connection version 2: Master - Slave (parallel)  
 (max 5 Slaves Parallel)**

