

Nidec

All for dreams



Power Installation Guide

***Commander C200
& C300***

***Unidrive M / HS
Frame 7 to 10***

Part Number: 0478-0234-10

Issue: 10

Original Instructions

For the purposes of compliance with the EU Machinery Directive 2006/42/EC, the English version of this manual is the Original Instructions. Manuals in other languages are Translations of the Original Instructions.

Documentation

Manuals are available to download from the following locations: <http://www.drive-setup.com/ctdownloads>

The information contained in this manual is believed to be correct at the time of printing and does not form part of any contract. The manufacturer reserves the right to change the specification of the product and its performance, and the contents of the manual, without notice.

Warranty and Liability

In no event and under no circumstances shall the manufacturer be liable for damages and failures due to misuse, abuse, improper installation, or abnormal conditions of temperature, dust, or corrosion, or failures due to operation outside the published ratings. The manufacturer is not liable for consequential and incidental damages. Contact the supplier of the dive for full details of the warranty terms.

Environmental policy

Control Techniques Ltd operates an Environmental Management System (EMS) that conforms to the International Standard ISO 14001.

Further information on our Environmental Policy can be found at: <http://www.drive-setup.com/environment>

Restriction of Hazardous Substances (RoHS)

The products covered by this manual comply with European and International regulations on the Restriction of Hazardous Substances including EU directive 2011/65/EU and the Chinese Administrative Measures for Restriction of Hazardous Substances in Electrical and Electronic Products.

Disposal and Recycling (WEEE)



When electronic products reach the end of their useful life, they must not be disposed of along with domestic waste but should be recycled by a specialist recycler of electronic equipment. Control Techniques products are designed to be easily dismantled into their major component parts for efficient recycling. The majority of materials used in the product are suitable for recycling.

Product packaging is of good quality and can be re-used. Large products are packed in wooden crates. Smaller products are packaged in strong cardboard cartons which have a high recycled fibre content. Cartons can be re-used and recycled. Polythene, used in protective film and bags for wrapping the product, can be recycled. When preparing to recycle or dispose of any product or packaging, please observe local legislation and best practice.

REACH legislation

EC Regulation 1907/2006 on the Registration, Evaluation, Authorisation and restriction of Chemicals (REACH) requires the supplier of an article to inform the recipient if it contains more than a specified proportion of any substance which is considered by the European Chemicals Agency (ECHA) to be a Substance of Very High Concern (SVHC) and is therefore listed by them as a candidate for compulsory authorisation.

Further information on our compliance with REACH can be found at: <http://www.drive-setup.com/reach>

Registered Office

Nidec Control Techniques Ltd
The Gro
Newtown
Powys
SY16 3BE
UK

Registered in England and Wales. Company Reg. No. 01236886.

Copyright

The contents of this publication are believed to be correct at the time of printing. In the interests of a commitment to a policy of continuous development and improvement, the manufacturer reserves the right to change the specification of the product or its performance, or the contents of the guide, without notice.

All rights reserved. No parts of this guide may be reproduced or transmitted in any form or by any means, electrical or mechanical including photocopying, recording or by an information storage or retrieval system, without permission in writing from the publisher.

Copyright © December 2018 Nidec Control Techniques Ltd

Contents

1	Safety information	12
1.1	Warnings, Cautions and Notes	12
1.2	Important safety information. Hazards. Competence of designers and installers	12
1.3	Responsibility	12
1.4	Compliance with regulations	12
1.5	Electrical hazards	13
1.6	Stored electrical charge	13
1.7	Mechanical hazards	13
1.8	Access to equipment	13
1.9	Environmental limits	13
1.10	Hazardous environments	13
1.11	Motor	14
1.12	Mechanical brake control	14
1.13	Adjusting parameters	14
1.14	Electromagnetic compatibility (EMC)	14
2	Product information	15
2.1	Introduction	15
2.2	Model number	15
2.3	Nameplate description	16
2.4	Ratings	17
2.5	Drive features	20
3	Mechanical installation	22
3.1	Safety information	22
3.2	Planning the installation	23
3.3	Terminal cover removal	25
3.4	Dimensions and mounting methods	27
3.5	Enclosure for standard drives	32
3.6	Enclosure design and drive ambient temperature	38
3.7	Heatsink fan operation	38
3.8	Enclosing standard drive for high environmental protection	39
3.9	External EMC filter	43
3.10	Terminal size and torque settings	48
3.11	Routine maintenance	49
4	Electrical installation	54
4.1	Power and ground connections	55
4.2	AC Supply requirements	58
4.3	Supplying the Unidrive M / Unidrive HS size 7, 8 and 9A drives with DC / DC bus paralleling	63
4.4	24 Vdc supply	63
4.5	Low voltage operation	65
4.6	Heatsink fan supply	66
4.7	Ratings	66
4.8	Output circuit and motor protection	67
4.9	Braking	70
4.10	Ground leakage	74
4.11	EMC (Electromagnetic compatibility)	75
5	Technical data	92
5.1	Drive technical data	92
5.2	Optional external EMC filters	118

6	UL listing information	120
6.1	UL file reference	120
6.2	Option modules, kits and accessories	120
6.3	Enclosure ratings	120
6.4	Mounting	120
6.5	Environment	120
6.6	Electrical Installation	121
6.7	Motor overload protection and thermal memory retention	121
6.8	External Class 2 supply	122
6.9	Requirement for Transient Surge Suppression	122
6.10	Modular Drive Systems	122

EU Declaration of Conformity

Control Techniques Ltd
The Gro
Newtown
Powys
SY16 3BE
UK

This declaration is issued under the sole responsibility of the manufacturer. The object of the declaration is in conformity with the relevant European Union harmonization legislation. The declaration applies to the variable speed drive products shown below:

Model number	Interpretation	Nomenclature aaaa - bbc ddddde
aaaa	Basic series	M100, M101, M200, M201, M300, M400, M600, M700, M701, M702, F300, H300, E200, E300, HS30, HS70, HS71, HS72, M000, RECT
bb	Frame size	01, 02, 03, 04, 05, 06, 07, 08, 09, 10, 11
c	Voltage rating	1 = 100 V, 2 = 200 V, 4 = 400 V, 5 = 575 V, 6 = 690 V
dddd	Current rating	Example 01000 = 100 A
e	Drive format	A = 6P Rectifier + Inverter (internal choke), D = Inverter, E = 6P Rectifier + Inverter (external choke), T = 12P Rectifier + Inverter (external choke)

The model number may be followed by additional characters that do not affect the ratings. The variable speed drive products listed above have been designed and manufactured in accordance with the following European harmonized standards:

EN 61800-5-1:2007	Adjustable speed electrical power drive systems - Part 5-1: Safety requirements - Electrical, thermal and energy
EN 61800-3: 2004+A1:2012	Adjustable speed electrical power drive systems - Part 3: EMC requirements and specific test methods
EN 61000-6-2:2005	Electromagnetic compatibility (EMC) - Part 6-2: Generic standards - Immunity for industrial environments
EN 61000-6-4: 2007+A1:2011	Electromagnetic compatibility (EMC) - Part 6-4: Generic standards - Emission standard for industrial environments
EN 61000-3-2:2014	Electromagnetic compatibility (EMC) - Part 3-2: Limits for harmonic current emissions (equipment input current ≤ 16 A per phase)
EN 61000-3-3:2013	Electromagnetic compatibility (EMC) - Part 3-3: Limitation of voltage changes, voltage fluctuations and flicker in public, low voltage supply systems, for equipment with rated current ≤ 16 A per phase and not subject to conditional connection

EN 61000-3-2:2014 Applicable where input current < 16 A. No limits apply for professional equipment where input power ≥ 1 kW.

These products comply with the Restriction of Hazardous Substances Directive (2011/65/EU), the Low Voltage Directive (2014/35/EU) and the Electromagnetic Compatibility Directive (2014/30/EU).



G Williams
Vice President, Technology
Date: 17th March 2016

These electronic drive products are intended to be used with appropriate motors, controllers, electrical protection components and other equipment to form complete end products or systems. Compliance with safety and EMC regulations depends upon installing and configuring drives correctly, including using the specified input filters.

The drives must be installed only by professional installers who are familiar with requirements for safety and EMC. Refer to the Product Documentation. An EMC data sheet is available giving detailed information. The assembler is responsible for ensuring that the end product or system complies with all the relevant laws in the country where it is to be used.

EU Declaration of Conformity

Nidec Control Techniques Ltd
The Gro
Newtown
Powys
SY16 3BE
UK

This declaration is issued under the sole responsibility of the manufacturer. The object of the declaration is in conformity with the relevant European Union harmonization legislation. The declaration applies to the variable speed drive products shown below:

Model number	Interpretation	Nomenclature aaaa - bbc ddddde
aaaa	Basic series	C200, C300
bb	Frame size	01, 02, 03, 04, 05, 06, 07, 08, 09
c	Voltage rating	1 = 100 V, 2 = 200 V, 4 = 400 V
dddd	Current rating	Example 01000 = 100 A
e	Drive format	A = 6P Rectifier + Inverter with internal choke, E = 6P Rectifier + Inverter (external choke)

The model number may be followed by other characters that do not affect the ratings.

The variable speed drive products listed above have been designed and manufactured in accordance with the following European harmonized standards:

EN 61800-5-1:2007	Adjustable speed electrical power drive systems - Part 5-1: Safety requirements - Electrical, thermal and energy
EN 61800-3: 2004+A1:2012	Adjustable speed electrical power drive systems - Part 3: EMC requirements and specific test methods
EN 61000-6-2:2005	Electromagnetic compatibility (EMC) - Part 6-2: Generic standards - Immunity for industrial environments
EN 61000-6-4: 2007+A1:2011	Electromagnetic compatibility (EMC) - Part 6-4: Generic standards - Emission standard for industrial environments
EN 61000-3-2:2014	Electromagnetic compatibility (EMC) - Part 3-2: Limits for harmonic current emissions (equipment input current ≤ 16 A per phase)
EN 61000-3-3:2013	Electromagnetic compatibility (EMC) - Part 3-3: Limitation of voltage changes, voltage fluctuations and flicker in public, low voltage supply systems, for equipment with rated current ≤ 16 A per phase and not subject to conditional connection

EN 61000-3-2:2014 Applicable where input current < 16 A. No limits apply for professional equipment where input power ≥ 1 kW.

These products comply with the Restriction of Hazardous Substances Directive (2011/65/EU), the Low Voltage Directive (2014/35/EU) and the Electromagnetic Compatibility Directive (2014/30/EU).



Jon Holman-White
Director of Research and Development
Date: 9th October 2018

These electronic drive products are intended to be used with appropriate motors, controllers, electrical protection components and other equipment to form complete end products or systems. Compliance with safety and EMC regulations depends upon installing and configuring drives correctly, including using the specified input filters.

The drives must be installed only by professional installers who are familiar with requirements for safety and EMC. Refer to the Product Documentation. An EMC data sheet is available giving detailed information. The assembler is responsible for ensuring that the end product or system complies with all the relevant laws in the country where it is to be used.

Declaration of Conformity (including 2006 Machinery Directive)

Control Techniques Ltd
The Gro
Newtown
Powys
SY16 3BE
UK

This declaration is issued under the sole responsibility of the manufacturer. The object of the declaration is in conformity with the relevant European Union harmonization legislation. The declaration applies to the variable speed drive products shown below:

Model number	Interpretation	Nomenclature aaaa - bbc ddddde
aaaa	Basic series	M300, M400, M600, M700, M701, M702, F300, H300, E200, E300, HS30, HS70, HS71, HS72, M000, RECT
bb	Frame size	01, 02, 03, 04, 05, 06, 07, 08, 09, 10, 11
c	Voltage rating	1 = 100 V, 2 = 200 V, 4 = 400 V, 5 = 575 V, 6 = 690 V
dddd	Current rating	Example 01000 = 100 A
e	Drive format	A = 6P Rectifier + Inverter (internal choke), D = Inverter, E = 6P Rectifier + Inverter (external choke), T = 12P Rectifier + Inverter (external choke)

The model number may be followed by additional characters that do not affect the ratings.

This declaration relates to these products when used as a safety component of a machine. Only the Safe Torque Off function may be used for a safety function of a machine. None of the other functions of the drive may be used to carry out a safety function.

These products fulfil all the relevant provisions of the Machinery Directive 2006/42/EC and the Electromagnetic Compatibility Directive (2014/30/EU).

EC type examination has been carried out by the following notified body:

TUV Rheinland Industrie Service GmbH
Am Grauen Stein
D-51105 Köln
Germany

EC type-examination certificate numbers:

01/205/5270.01/14 dated 2014-11-11

01/205/5387.01/15 dated 2015-01-29

01/205/5383.02/15 dated 2015-04-21

Notified body identification number: 0035

The harmonized standards used are shown below:

EN 61800-5-1:2007	Adjustable speed electrical power drive systems - Part 5-1: Safety requirements - Electrical, thermal and energy
EN 61800-5-2:2007	Adjustable speed electrical power drive systems - Part 5-2: Safety requirements - Functional
EN ISO 13849-1:2008	Safety of Machinery, Safety-related parts of control systems, General principles for design
EN ISO 13849-2:2008	Safety of machinery, Safety-related parts of control systems. Validation
EN 61800-3: 2004+A1:2012	Adjustable speed electrical power drive systems - Part 3: EMC requirements and specific test methods
EN 62061:2005	Safety of machinery, Functional safety of safety related electrical, electronic and programmable electronic control systems

Person authorised to complete the technical file:

P Knight

Conformity Engineer

Newtown, Powys, UK



G. Williams

Vice President, Technology

Date: 17th March 2016

Place: Newtown, Powys, UK

IMPORTANT NOTICE

These electronic drive products are intended to be used with appropriate motors, controllers, electrical protection components and other equipment to form complete end products or systems. Compliance with safety and EMC regulations depends upon installing and configuring drives correctly, including using the specified input filters.

The drives must be installed only by professional installers who are familiar with requirements for safety and EMC. Refer to the Product Documentation. An EMC data sheet is available giving detailed information. The assembler is responsible for ensuring that the end product or system complies with all the relevant laws in the country where it is to be used.

EU Declaration of Conformity (including 2006 Machinery Directive)

Nidec Control Techniques Ltd
The Gro
Newtown
Powys
SY16 3BE
UK

This declaration is issued under the sole responsibility of the manufacturer. The object of the declaration is in conformity with the relevant European Union harmonization legislation. The declaration applies to the variable speed drive products shown below:

Model number	Interpretation	Nomenclature aaaa - bbc ddddde
aaaa	Basic series	C300
bb	Frame size	01, 02, 03, 04, 05, 06, 07, 08, 09
c	Voltage rating	1 = 100 V, 2 = 200 V, 4 = 400 V
dddd	Current rating	Example 01000 = 100 A
e	Drive format	A = 6P Rectifier + Inverter with internal choke, E = 6P Rectifier + Inverter (external choke)

The model number may be followed by additional characters that do not affect the ratings.

This declaration relates to these products when used as a safety component of a machine. Only the Safe Torque Off function may be used for a safety function of a machine. None of the other functions of the drive may be used to carry out a safety function.

These products fulfil all the relevant provisions of the Machinery Directive (2006/42/EC) and the Electromagnetic Compatibility Directive (2014/30/EU).

EC type examination has been carried out by the following notified body:

TUV Rheinland Industrie Service GmbH
 Am Grauen Stein
 D-51105 Köln
 Germany

EC type-examination certificate numbers:

Frame sizes 1 to 4: 01/205/5383.03/18 dated 2018-08-16

Frame sizes 5 to 9: 01/205/5387.02/18 dated 2018-08-16

Notified body identification number: 0035

The harmonized standards used are shown below:

EN 61800-5-2:2007	Adjustable speed electrical power drive systems - Part 5-2: Safety requirements - Functional
EN 61800-5-1:2007 (in extracts)	Adjustable speed electrical power drive systems - Part 5-1: Safety requirements - Electrical, thermal and energy
EN 61800-3: 2004+A1:2012	Adjustable speed electrical power drive systems - Part 3: EMC requirements and specific test methods
EN ISO 13849-1:2008 + AC:2009	Safety of Machinery, Safety-related parts of control systems, General principles for design
EN 62061:2005 + AC:2010 + A1:2013	Safety of machinery, Functional safety of safety related electrical, electronic and programmable electronic control systems
IEC 61508 Parts 1 - 7:2010	Functional safety of electrical/ electronic/programmable electronic safety-related systems

Person authorised to complete the technical file:

P Knight

Conformity Engineer

Newtown, Powys, UK



Jon Holman-White

Director of Research and Development

Date: 9th October 2018

Place: Newtown, Powys, UK

IMPORTANT NOTICE

These electronic drive products are intended to be used with appropriate motors, controllers, electrical protection components and other equipment to form complete end products or systems. It is the responsibility of the installer to ensure that the design of the complete machine, including its safety-related control system, is carried out in accordance with the requirements of the Machinery Directive and any other relevant legislation. The use of a safety-related drive in itself does not ensure the safety of the machine. Compliance with safety and EMC regulations depends upon installing and configuring drives correctly, including using the specified input filters. The drive must be installed only by professional installers who are familiar with requirements for safety and EMC. The assembler is responsible for ensuring that the end product or system complies with all relevant laws in the country where it is to be used. For more information regarding Safe Torque Off, refer to the Product Documentation.

1 Safety information

1.1 Warnings, Cautions and Notes



A Warning contains information which is essential for avoiding a safety hazard.



A Caution contains information which is necessary for avoiding a risk of damage to the product or other equipment.

NOTE

A **Note** contains information, which helps to ensure correct operation of the product.

1.2 Important safety information. Hazards. Competence of designers and installers

This guide applies to products which control electric motors either directly (drives) or indirectly (controllers, option modules and other auxiliary equipment and accessories). In all cases the hazards associated with powerful electrical drives are present, and all safety information relating to drives and associated equipment must be observed.

Specific warnings are given at the relevant places in this guide.

Drives and controllers are intended as components for professional incorporation into complete systems. If installed incorrectly they may present a safety hazard. The drive uses high voltages and currents, carries a high level of stored electrical energy, and is used to control equipment which can cause injury. Close attention is required to the electrical installation and the system design to avoid hazards either in normal operation or in the event of equipment malfunction. System design, installation, commissioning/start-up and maintenance must be carried out by personnel who have the necessary training and competence. They must read this safety information and this guide carefully.

1.3 Responsibility

It is the responsibility of the installer to ensure that the equipment is installed correctly with regard to all instructions given in this guide. They must give due consideration to the safety of the complete system, so as to avoid the risk of injury both in normal operation and in the event of a fault or of reasonably foreseeable misuse.

The manufacturer accepts no liability for any consequences resulting from inappropriate, negligent or incorrect installation of the equipment.

1.4 Compliance with regulations

The installer is responsible for complying with all relevant regulations, such as national wiring regulations, accident prevention regulations and electromagnetic compatibility (EMC) regulations. Particular attention must be given to the cross-sectional areas of conductors, the selection of fuses or other protection, and protective ground (earth) connections.

This guide contains instructions for achieving compliance with specific EMC standards.

All machinery to be supplied within the European Union in which this product is used must comply with the following directives:

2006/42/EC Safety of machinery.

2014/30/EU: Electromagnetic Compatibility.

1.5 Electrical hazards

The voltages used in the drive can cause severe electrical shock and/or burns, and could be lethal. Extreme care is necessary at all times when working with or adjacent to the drive. Hazardous voltage may be present in any of the following locations:

- AC and DC supply cables and connections
- Output cables and connections
- Many internal parts of the drive, and external option units

Unless otherwise indicated, control terminals are single insulated and must not be touched.

The supply must be disconnected by an approved electrical isolation device before gaining access to the electrical connections.

The STOP and Safe Torque Off functions of the drive do not isolate dangerous voltages from the output of the drive or from any external option unit.

The drive must be installed in accordance with the instructions given in this guide. Failure to observe the instructions could result in a fire hazard.

1.6 Stored electrical charge

The drive contains capacitors that remain charged to a potentially lethal voltage after the AC supply has been disconnected. If the drive has been energized, the AC supply must be isolated at least ten minutes before work may continue.

1.7 Mechanical hazards

Careful consideration must be given to the functions of the drive or controller which might result in a hazard, either through their intended behaviour or through incorrect operation due to a fault. In any application where a malfunction of the drive or its control system could lead to or allow damage, loss or injury, a risk analysis must be carried out, and where necessary, further measures taken to reduce the risk - for example, an over-speed protection device in case of failure of the speed control, or a fail-safe mechanical brake in case of loss of motor braking.

With the sole exception of the Safe Torque Off function, none of the drive functions must be used to ensure safety of personnel, i.e. they must not be used for safety-related functions.

The Safe Torque Off function may be used in a safety-related application. The system designer is responsible for ensuring that the complete system is safe and designed correctly according to the relevant safety standards.

The design of safety-related control systems must only be done by personnel with the required training and experience. The Safe Torque Off function will only ensure the safety of a machine if it is correctly incorporated into a complete safety system. The system must be subject to a risk assessment to confirm that the residual risk of an unsafe event is at an acceptable level for the application.

1.8 Access to equipment

Access must be restricted to authorized personnel only. Safety regulations which apply at the place of use must be complied with.

1.9 Environmental limits

Instructions in this guide regarding transport, storage, installation and use of the equipment must be complied with, including the specified environmental limits. This includes temperature, humidity, contamination, shock and vibration. Drives must not be subjected to excessive physical force.

1.10 Hazardous environments

The equipment must not be installed in a hazardous environment (i.e. a potentially explosive environment).

1.11 Motor

The safety of the motor under variable speed conditions must be ensured.

To avoid the risk of physical injury, do not exceed the maximum specified speed of the motor.

Low speeds may cause the motor to overheat because the cooling fan becomes less effective, causing a fire hazard. The motor should be installed with a protection thermistor. If necessary, an electric forced vent fan should be used.

The values of the motor parameters set in the drive affect the protection of the motor. The default values in the drive must not be relied upon. It is essential that the correct value is entered in the Motor Rated Current parameter.

1.12 Mechanical brake control

Any brake control functions are provided to allow well co-ordinated operation of an external brake with the drive. While both hardware and software are designed to high standards of quality and robustness, they are not intended for use as safety functions, i.e. where a fault or failure would result in a risk of injury. In any application where the incorrect operation of the brake release mechanism could result in injury, independent protection devices of proven integrity must also be incorporated.

1.13 Adjusting parameters

Some parameters have a profound effect on the operation of the drive. They must not be altered without careful consideration of the impact on the controlled system. Measures must be taken to prevent unwanted changes due to error or tampering.

1.14 Electromagnetic compatibility (EMC)

Installation instructions for a range of EMC environments are provided in the relevant Power Installation Guide. If the installation is poorly designed or other equipment does not comply with suitable standards for EMC, the product might cause or suffer from disturbance due to electromagnetic interaction with other equipment. It is the responsibility of the installer to ensure that the equipment or system into which the product is incorporated complies with the relevant EMC legislation in the place of use.

2 Product information

2.1 Introduction

This guide provides the information necessary to install the following drive models:

Unidrive M200 to M400 frame 7 to 9

Unidrive M600 to M702 frame 7 to 10

Unidrive HS70 to HS72 frame 7 to 10

Commander C200 to C300 frame 7 to 9

This guide focuses on the drive power section, for example: electrical installation of the supply / motor cables and mechanical installation of the drive.

For information about the drive control section, for example: parameter set up information, control and encoder connections, please refer to the *Control User Guide*.

2.2 Model number

The model numbers for the *Unidrive M/HS* and *Commander* product range are formed as illustrated below:

Figure 2-1 Model number

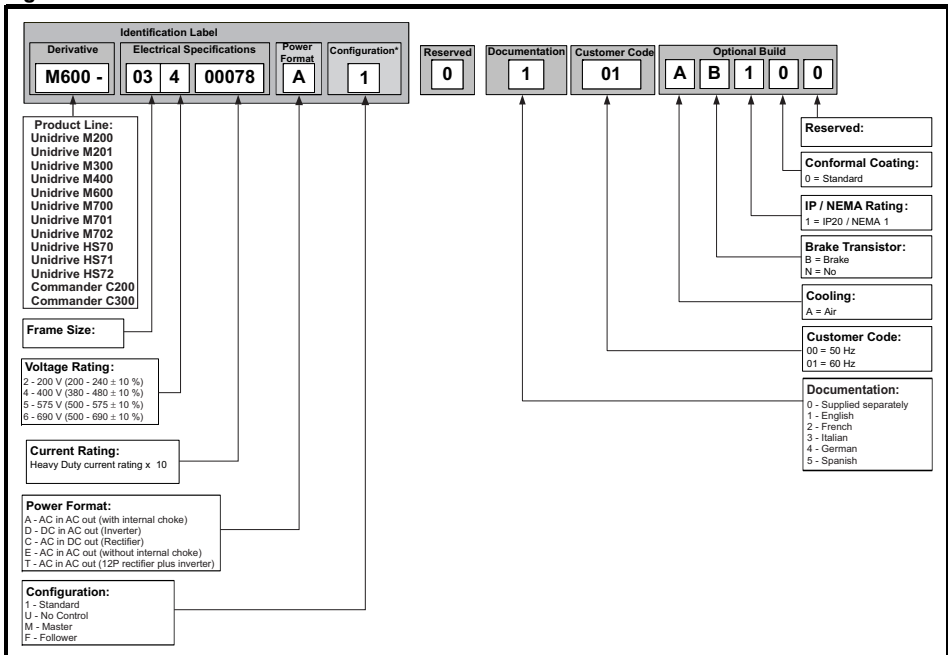

NOTE

For simplicity a Frame 9 drive with no internal choke (i.e. Model 09xxxxxxE) is referred to as a Frame 9E and a Frame 9 drive with an internal choke (i.e. Model 09xxxxxxA) is referred to as a Frame 9A. Any reference to Frame 9 is applicable to both sizes 9E and 9A. All Frame size 10 drives are supplied with no internal choke.

2.3 Nameplate description

Figure 2-2 Typical drive rating labels

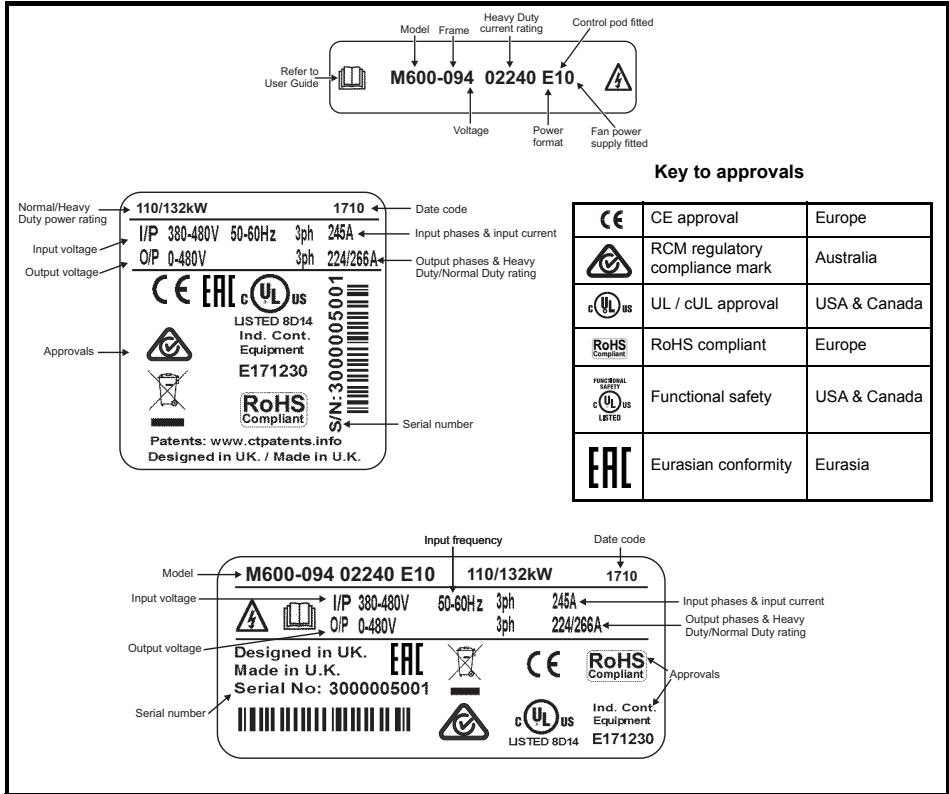

Refer to Figure 2-1 *Model number* on page 15 for further information relating to the labels.

NOTE Date code format

The date code is four numbers. The first two numbers indicate the year and the remaining numbers indicate the week of the year in which the drive was built.

Example:

A date code of **1710** would correspond to week 10 of year 2017.

2.4 Ratings



Fuses

The AC supply to the drive must be installed with suitable protection against overload and short-circuits. The following section shows recommended fuse ratings. Failure to observe this requirement will cause risk of fire.

NOTE

Nominal cables sizes below are based on the cable installation method B2 (ref: IEC60364-5-52:2001) unless otherwise specified, and are provided as a guide only. Ensure cables used suit local wiring regulations.

Table 2-1 200 V drive ratings, cable sizes and fuse ratings

Model	Max. cont. input current	Fuse				Nominal cable size				Normal Duty			Heavy Duty		
		IEC		UL		European		USA		Max. cont. output current	Nom power @ 230 V	Motor power @ 230 V	Max. cont. output current	Nom power @ 230 V	Motor power @ 230 V
		3ph	Nom	Class	Nom	Class	Input	Output	Input						
		A	A		A		A	mm ²	mm ²	AWG or kcmil	AWG or kcmil	A	kW	hp	A
07200610	67	80	gG	80	CC, J or T*	35	35	2	2	75	18.5	25	61	15	20
07200750	84	100		100		35	35	1	1	94	22	30	75	18.5	25
07200830	105	125		125		70	70	1/0	1/0	117	30	40	83	22	30
08201160	137	200	gR	200	HSJ	95	95	3/0	3/0	149	37	50	116	30	40
08201320	166	200		225		2 x 70	2 x 70	2 x 1	2 x 1	180	45	60	132	37	50
09201760	205	250	gR	250	HSJ	2 x 70 (B1)	2 x 95 (B2)	2 x 2/0		216	55	75	176	45	60
09202190	260	315		300		2 x 95 (B1)	2 x 120 (B2)	2 x 4/0		266	75	100	219	55	75
10202830	305	400	gR	400	HSJ	2 x 120 (B1)	2 x 120 (C)	2 x 300	2 x 250	325	90	125	283	75	100
10203000	361	450		450		2 x 150 (C)		2 x 300	2 x 300	360	110	150	300	90	125

Table 2-2 400 V drive ratings, cable sizes and fuse ratings

Model	Max. cont. input current	Fuse				Nominal cable size				Normal Duty			Heavy Duty		
		IEC		UL		European		USA		Max. cont. output current	Nom power @ 400 V	Motor power @ 460 V	Max. cont. output current	Nom power @ 400 V	Motor power @ 460 V
		3ph	Nom	Class	Nom	Class	Input	Output	Input						
		A	A		A		A	mm ²	mm ²	AWG or kcmil	AWG or kcmil	A	kW	hp	A
07400660	74	100	gG	80	CC, J or T*	35	35	1	1	79	37	60	66	30	50
07400770	88	100		100		50	50	2	2	94	45	60	77	37	60
07401000	105	125		125		70	70	1/0	1/0	112	55	75	100	45	75
08401340	155	250	gR	225	HSJ	2 x 50	2 x 50	2 x 1	2 x 1	155	75	100	134	55	100
08401570	177	250		225		2 x 70	2 x 70	2 x 1/0	2 x 1/0	184	90	150	157	75	125
09402000	232	315	gR	300	HSJ	2 x 70 (B1)	2 x 95 (B2)	2 x 3/0	2 x 2/0	221	110	150	200**	90	150
09402240	267			350		2 x 95 (B1)	2 x 120 (B2)	2 x 4/0	2 x 4/0	266**	132	200	224**	110	150
10402700	332	400	gR	400	HSJ	2 x 120 (C)	2 x 120 (B2)	2 x 300	2 x 250	320	160	250	270	132	200
10403200	397	450		450		2 x 150 (C)	2 x 150 (B2)	2 x 350	2 x 300	361	200	300	320**	160	250

* These fuses are fast acting.

** These ratings are for 2 kHz switching frequency. For ratings at 3 kHz switching frequency refer to the Power and current ratings in section 5.1.2 *Power and current ratings (Derating for switching frequency and temperature)* on page 94.

Table 2-3 575 V drive ratings, cable sizes and fuse ratings

Model	Max. cont. input current	Fuse				Nominal cable size				Normal Duty			Heavy Duty		
		IEC		UL		European		USA		Max. cont. output current	Nom power @ 575 V	Motor power @ 575 V	Max. cont. output current	Nom power @ 575 V	Motor power @ 575 V
		3ph	Nom	Class	Nom	Class	Input	Output	Input						
		A	A		A		mm ²	mm ²	AWG	AWG	A	kW	hp	A	kW
07500440	45	50	gG	50	CC, J or T*	16	16	4	4	53	45	50	44	30	40
07500550	62	80		80		25	25	3	3	73	55	60	55	37	50
08500630	83	125	gR	100	HSJ	35	35	1	1	86	75	75	63	45	60
08500860	104	160		150		50	50	1	1	108	90	100	86	55	75
09501040	166	150	gR	150	HSJ	2 x 70 (B2)	2 x 35 (B2)	2 x 1	2 x 3	125	110	125	104	75	100
09501310	166	200		175						2 x 50 (B2)	2 x 1	155	110	150	131
10501520	197	250	gR	250	HSJ	2 x 70 (B2)	2 x 70 (B2)	2 x 2/0	2 x 2/0	200	130	200	152	110	150
10501900	218									200	150	200	190	132	200

* These fuses are fast acting.

Table 2-4 690 V drive ratings, cable sizes and fuse ratings

Model	Max. cont. input current	Fuse				Nominal cable size				Normal Duty			Heavy Duty		
		IEC		UL		European		USA		Max. cont. output current	Nom power @ 690 V	Motor power @ 690 V	Max. cont. output current	Nom power @ 690 V	Motor power @ 690 V
		3ph	Nom	Class	Nom	Class	Input	Output	Input						
		A	A		A		mm ²	mm ²	AWG	AWG	A	kW	hp	A	kW
07600190	20	25	gG	25	CC, J or T*	10	10	8	8	23	18.5	25	19	15	20
07600240	26	32		30		10	10	6	6	30	22	30	24	18.5	25
07600290	31	40		35		10	10	6	6	36	30	40	29	22	30
07600380	39	50		50		16	16	4	4	46	37	50	38	30	40
07600440	44	50		50		16	16	4	4	52	45	60	44	37	50
07600540	62	80		80		25	25	3	3	73	55	75	54	45	60
08600630	83	125	gR	100	HSJ	50	50	2	2	86	75	100	63	55	75
08600860	104	160		150		70	70	1/0	1/0	108	90	125	86	75	100
09601040	149	150	gR	150	HSJ	2 x 50 (B2)	2 x 35 (B2)	2 x 1	2 x 3	125	110	150	104	90	125
09601310	171	200		200						2 x 70 (B2)	2 x 50 (B2)	2 x 1/0	2 x 1	155	132
10601500	202	225	gR	250	HSJ	2 x 70 (B2)	2 x 70 (B2)	2 x 2/0	2 x 1/0	172	160	200	150	132	175
10601780	225	250								200	2 x 95 (B2)	2 x 3/0	2 x 2/0	197	185

* These fuses are fast acting.

NOTE Refer to Chapter 5.1 *Drive technical data* on page 92 for maximum fuse rating, maximum cable size and peak currents.

Table 2-5 Protective ground cable ratings

Input phase conductor size	Minimum ground conductor size
≤ 10 mm ²	Either 10 mm ² or two conductors of the same cross-sectional area as the input phase conductor
> 10 mm ² and ≤ 16 mm ²	The same cross-sectional area as the input phase conductor
> 16 mm ² and ≤ 35 mm ²	16 mm ²
> 35 mm ²	Half of the cross-sectional area of the input phase conductor

Typical short term overload limits

The maximum percentage overload limit changes depending on the selected motor. Variations in motor rated current, motor power factor and motor leakage inductance all result in changes in the maximum possible overload. Typical values are shown in the table below:

Table 2-6 Typical overload limits

Operating mode	RFC from cold	RFC from 100 %	Open loop from cold	Open loop from 100 %
Normal Duty overload with motor rated current = Maximum drive normal duty rated current	110 % for 165 s	110 % for 9 s	110 % for 165 s	110 % for 9 s
Heavy Duty overload with motor rated current = Maximum drive Heavy duty rated current (size 8 and below)	200 % for 28 s	200 % for 3 s	150 % for 60 s	150 % for 7 s
Heavy Duty overload with motor rated current = Maximum drive Heavy duty rated current (size 9 and 10)	175 % for 42 s	175 % for 5 s	136 % for 81 s	136 % for 11 s

Generally the drive rated current is higher than the matching motor rated current allowing a higher level of overload than the default setting.

The time allowed in the overload region is proportionally reduced at very low output frequency on some drive ratings.

NOTE The maximum overload level which can be attained is independent of the speed.

Output current

The continuous output current ratings given on the rating label are for maximum 40 °C (104 °F), 1000 m altitude and 3 kHz switching frequency (except where shown). Derating is required for higher switching frequencies, ambient temperatures >40 °C (104 °F) and higher altitude. For derating information, refer to *Chapter 5 Technical data* on page 92

Input current

The input current is affected by the supply voltage and impedance. The input current given on the rating label is the typical input current and is stated for a balanced supply.

2.5 Drive features

Figure 2-3 Features of the drive (size 7 to 10)- Unidrive M700 shown

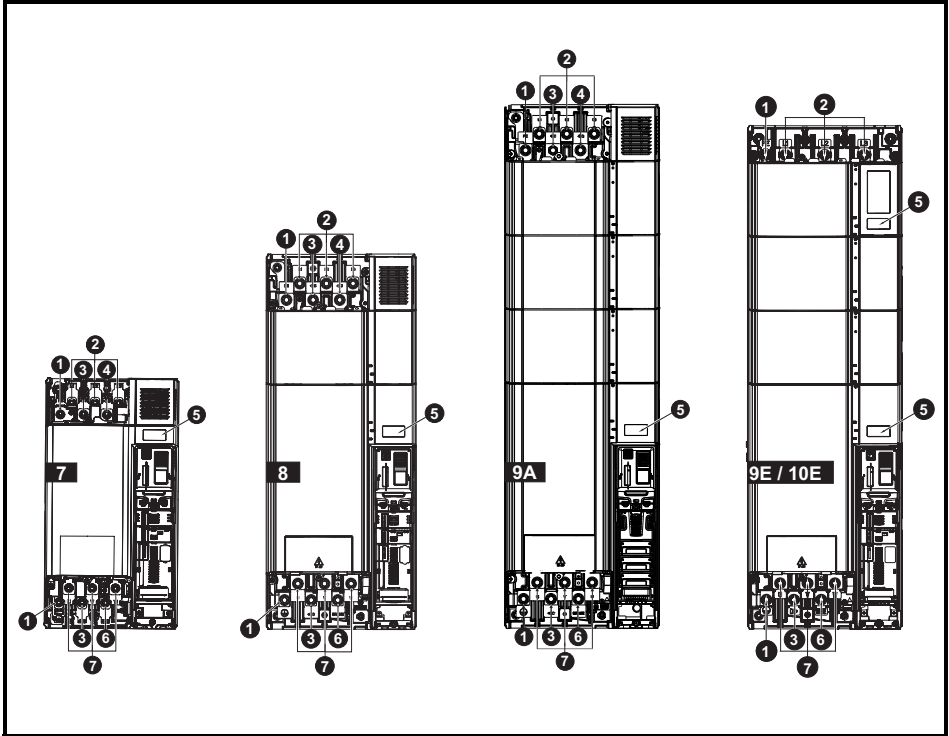







Key

- | | | | |
|-----------------------|--------------------------|----------------------|-------------|
| 1. Ground connections | 2. AC supply connections | 3. DC bus + | 4. DC bus - |
| 5. Rating label | 6. Braking terminal | 7. Motor connections | |

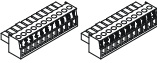
2.5.1 Items supplied with the drive

The drive is supplied with a copy of the *Power Installation Guide* and a copy of the *Control Getting Started Guide / Quick Start Guide*, a safety information booklet, the *Certificate of Quality* and an accessory kit box including the items shown in Table 2-7.

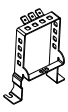
Table 2-7 Parts supplied with the drive

Description	Size 7	Size 8	Size 9A / 9E	Size 10E
Control connectors (1 to 11 and 21 to 31)				
		x 1*	x 1*	
Control connector (1 to 13)				
		x 1**		
Relay connector				
		x 1***		
24 V power supply connector				
		x 1***		
Grounding bracket				
		x 1		
Surface mounting brackets				
	x 2		x 2	

* Supplied with *Unidrive M700 / M701 / M600* only.

** Supplied with *Unidrive M702* only.

*** Supplied with *Unidrive M600 to M702* only.

3 Mechanical installation

3.1 Safety information



Follow the instructions

The mechanical and electrical installation instructions must be adhered to. Any questions or doubt should be referred to the supplier of the equipment. It is the responsibility of the owner or user to ensure that the installation of the drive and any external option unit, and the way in which they are operated and maintained, comply with the requirements of the Health and Safety at Work Act in the United Kingdom or applicable legislation and regulations and codes of practice in the country in which the equipment is used.



Stored charge

The drive contains capacitors that remain charged to a potentially lethal voltage after the AC supply has been disconnected. If the drive has been energized, the AC supply must be isolated at least ten minutes before work may continue.

Normally, the capacitors are discharged by an internal resistor. Under certain, unusual fault conditions, it is possible that the capacitors may fail to discharge, or be prevented from being discharged by a voltage applied to the output terminals. If the drive has failed in a manner that causes the display to go blank immediately, it is possible the capacitors will not be discharged. In this case, consult Nidec Industrial Automation or their authorized distributor.



Competence of the installer

The drive must be installed by professional assemblers who are familiar with the requirements for safety and EMC. The assembler is responsible for ensuring that the end product or system complies with all the relevant laws in the country where it is to be used.



Enclosure

The drive is intended to be mounted in an enclosure which prevents access except by trained and authorized personnel, and which prevents the ingress of contamination. It is designed for use in an environment classified as pollution degree 2 in accordance with IEC 60664-1. This means that only dry, non-conducting contamination is acceptable.

3.2 Planning the installation

The following considerations must be made when planning the installation:

3.2.1 Access

Access must be restricted to authorized personnel only. Safety regulations which apply at the place of use must be complied with.

The IP (Ingress Protection) rating of the drive is installation dependent. For further information, refer to section 3.8 *Enclosing standard drive for high environmental protection* on page 39.

3.2.2 Environmental protection

The drive must be protected from:

- Moisture, including dripping water or spraying water and condensation. An anti-condensation heater may be required, which must be switched off when the drive is running.
- Contamination with electrically conductive material
- Contamination with any form of dust which may restrict the fan, or impair airflow over various components
- Temperature beyond the specified operating and storage ranges
- Corrosive gasses

NOTE

During installation it is recommended that the vents on the drive are covered to prevent debris (e.g. wire off-cuts) from entering the drive.

3.2.3 Cooling

The heat produced by the drive must be removed without its specified operating temperature being exceeded. Note that a sealed enclosure gives much reduced cooling compared with a ventilated one, and may need to be larger and/or use internal air circulating fans.

For further information, refer to section 3.5 *Enclosure for standard drives* on page 32.

3.2.4 Electrical safety

The installation must be safe under normal and fault conditions. Electrical installation instructions are given in Chapter 4 *Electrical installation* on page 54.

3.2.5 Fire protection

The drive enclosure is not classified as a fire enclosure. A separate fire enclosure must be provided.

For installation in the USA, a NEMA 12 enclosure is suitable.

For installation outside the USA, the following (based on IEC 62109-1, standard for PV inverters) is recommended.

Enclosure can be metal and/or polymeric, polymer must meet requirements which can be summarized for larger enclosures as using materials meeting at least UL 94 class 5VB at the point of minimum thickness.

Air filter assemblies to be at least class V-2.

The location and size of the bottom shall cover the area shown in Figure 3-1. Any part of the side which is within the area traced out by the 5° angle is also considered to be part of the bottom of the fire enclosure.

Figure 3-1 Fire enclosure bottom layout

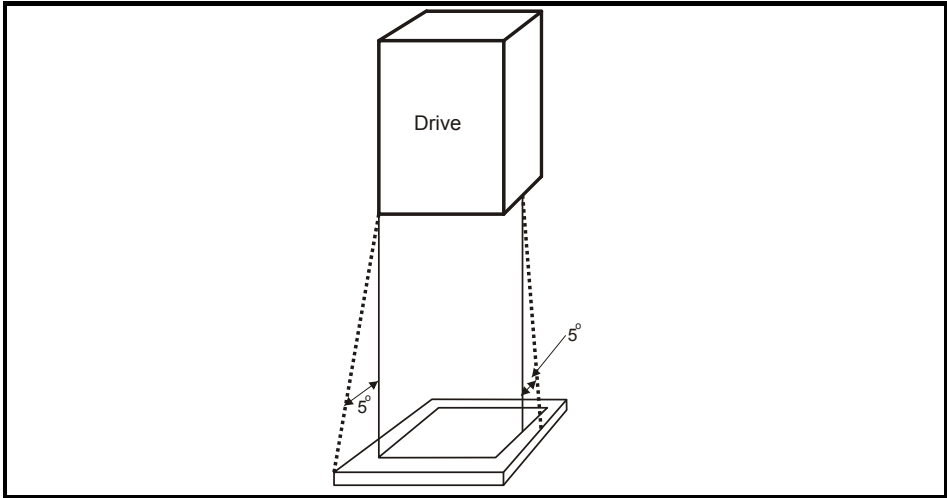

The bottom, including the part of the side considered to be part of the bottom, must be designed to prevent escape of burning material - either by having no openings or by having a baffle construction. This means that openings for cables etc. must be sealed with materials meeting the 5VB requirement, or else have a baffle above. See Figure 3-2 for acceptable baffle construction. This does not apply for mounting in an enclosed electrical operating area (restricted access) with concrete floor.

Figure 3-2 Fire enclosure baffle construction

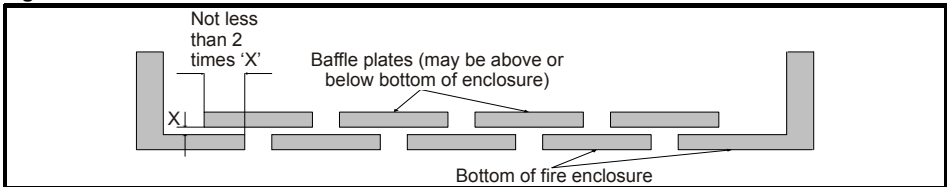

3.2.6 Electromagnetic compatibility

Variable speed drives are powerful electronic circuits which can cause electromagnetic interference if not installed correctly with careful attention to the layout of the wiring.

Some simple routine precautions can prevent disturbance to typical industrial control equipment.

If it is necessary to meet strict emission limits, or if it is known that electromagnetically sensitive equipment is located nearby, then full precautions must be observed. In-built into the drive, is an internal EMC filter, which reduces emissions under certain conditions. If these conditions are exceeded, then the use of an external EMC filter may be required at the drive inputs, which must be located very close to the drives. Space must be made available for the filters and allowance made for carefully segregated wiring. Both levels of precautions are covered in section 4.11 *EMC (Electromagnetic compatibility)* on page 75.

3.2.7 Hazardous areas

The drive must not be located in a classified hazardous area unless it is installed in an approved enclosure and the installation is certified

3.3 Terminal cover removal



Isolation device

The AC and / or DC power supply must be disconnected from the drive using an approved isolation device before any cover is removed from the drive or before any servicing work is performed.



Stored charge

The drive contains capacitors that remain charged to a potentially lethal voltage after the AC and / or DC power supply has been disconnected. If the drive has been energized, the power supply must be isolated at least ten minutes before work may continue.

Normally, the capacitors are discharged by an internal resistor. Under certain, unusual fault conditions, it is possible that the capacitors may fail to discharge, or be prevented from being discharged by a voltage applied to the output terminals. If the drive has failed in a manner that causes the display to go blank immediately, it is possible the capacitors will not be discharged. In this case, consult Nidec Industrial Automation or their authorized distributor.

3.3.1 Removing the terminal covers

Figure 3-3 Location and identification of terminal covers

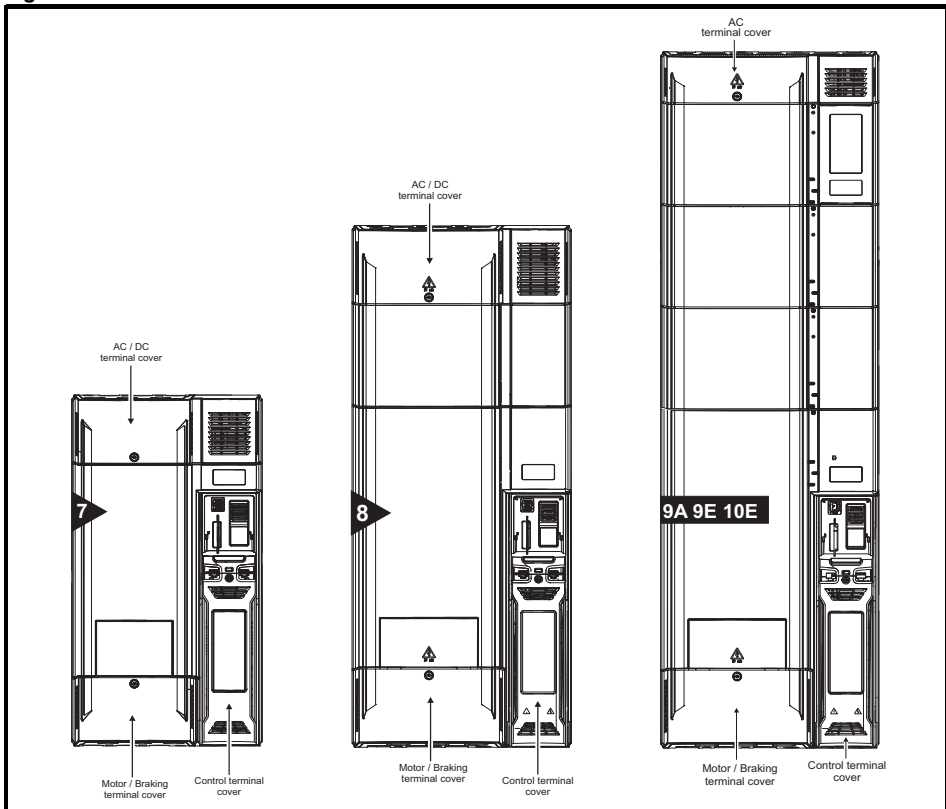
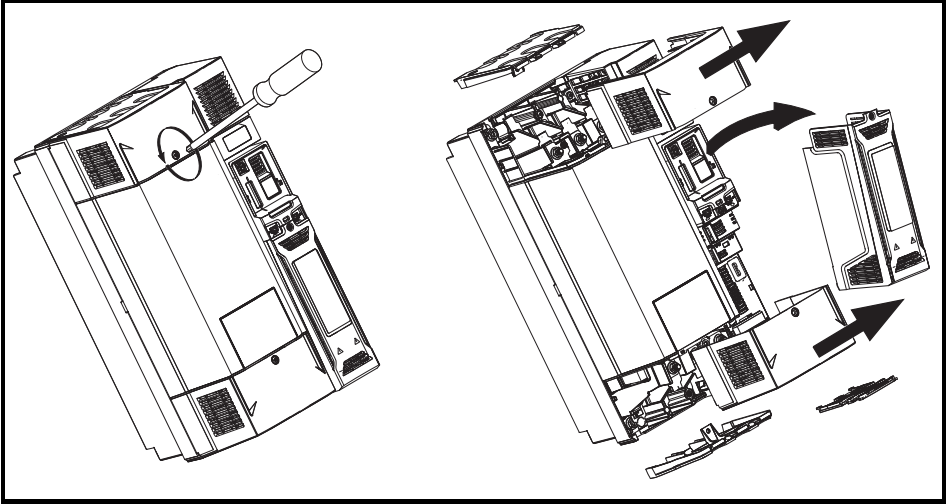

Figure 3-4 Removing the size 7 to 10 terminal covers (Unidrive M600 to M702 size 7 shown)



When replacing the terminal covers, the screws should be tightened to a maximum torque of 1 N m (0.7 lb ft).

3.3.2 Removing the finger-guard and DC terminal cover break-outs

Figure 3-5 Removing the finger-guard break-outs

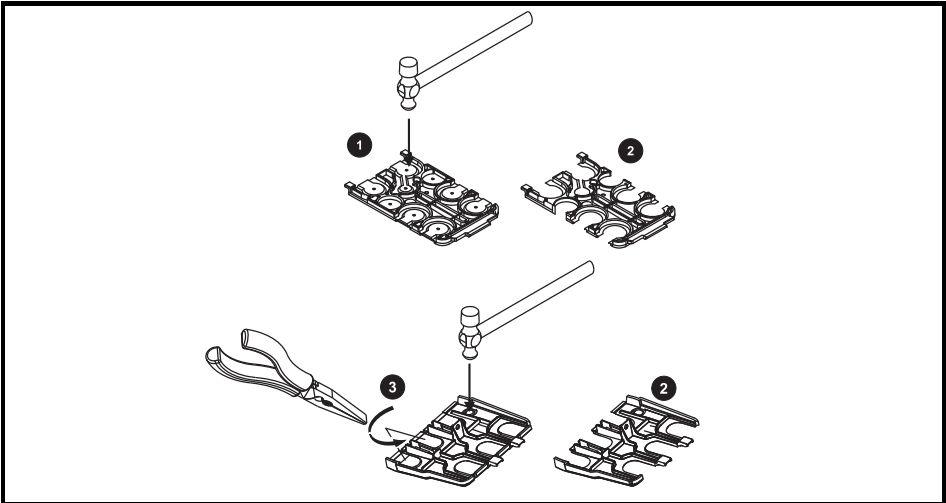

All sizes:

Place the finger-guard on a flat solid surface and hit relevant break-outs with hammer as shown (1). Pliers can be used to remove the breakouts, grasp the relevant break-out with pliers and twist it as shown (3). Continue until all the required break-outs have been removed (2). Remove any flash / sharp edges once the break-outs have been removed.



Grommets must be installed to ensure ingress protection to IP20 and to avoid the risk of fire in the event of a major internal failure.

Grommet kits are available for size 7 to 10 finger guards. For size 8 to 10, two versions are available allowing for either single or double cable entries.

Table 3-1 Grommet kits

Drive size	Part number	Picture
Size 7 - Kit of 8 x single entry grommets	3470-0086	
Size 8 - Kit of 8 x single entry grommets	3470-0089	
Size 8 - Kit of 8 x double entry grommets	3470-0090	
Size 9 and 10 - Kit of 8 x double entry grommets	3470-0107	

3.4 Dimensions and mounting methods

Drive sizes 7 to 10 can be either surface or through-panel mounted using the appropriate brackets.



If the drive has been used at high load levels for a period of time, the heatsink can reach temperatures in excess of 70 °C (158 °F). Human contact with the heatsink should be prevented.



Many of the drives in this product range weigh in excess of 15 kg (33 lb). Use appropriate safeguards when lifting these models. A full list of drive weights can be found in Table 5-14 *Overall drive weights* on page 106.

3.4.1 Drive dimensions

Figure 3-6 Drive dimensions (Unidrive M700 size 8 shown)

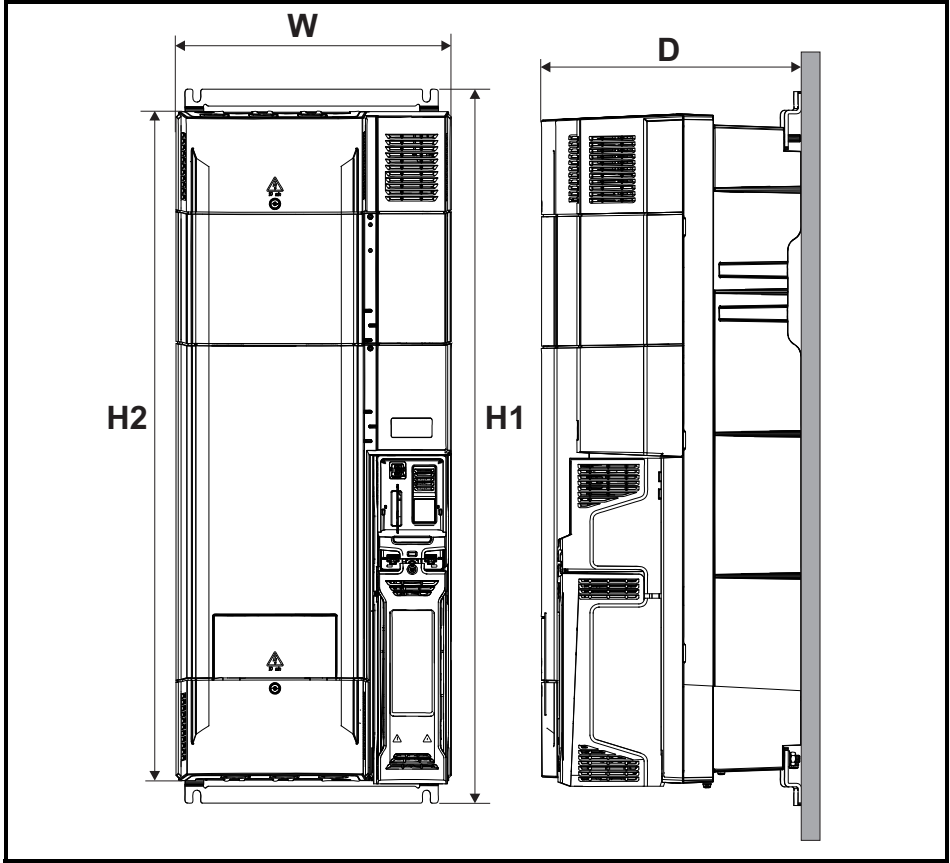

Size	H1		H2		W		D	
	mm	in	mm	in	mm	in	mm	in
7	557	21.93	508	20	270	10.63	280	11.02
8	804	31.65	753	29.65	310	12.21	290	11.42
9E and 10E	1069	42.09	1010	39.70	310	12.21	290	11.42
9A	1108	43.61	1049	41.30	310	12.21	290	11.42

3.4.2 Surface mounting

Figure 3-7 Surface mounting dimensions (size 7 to 10)

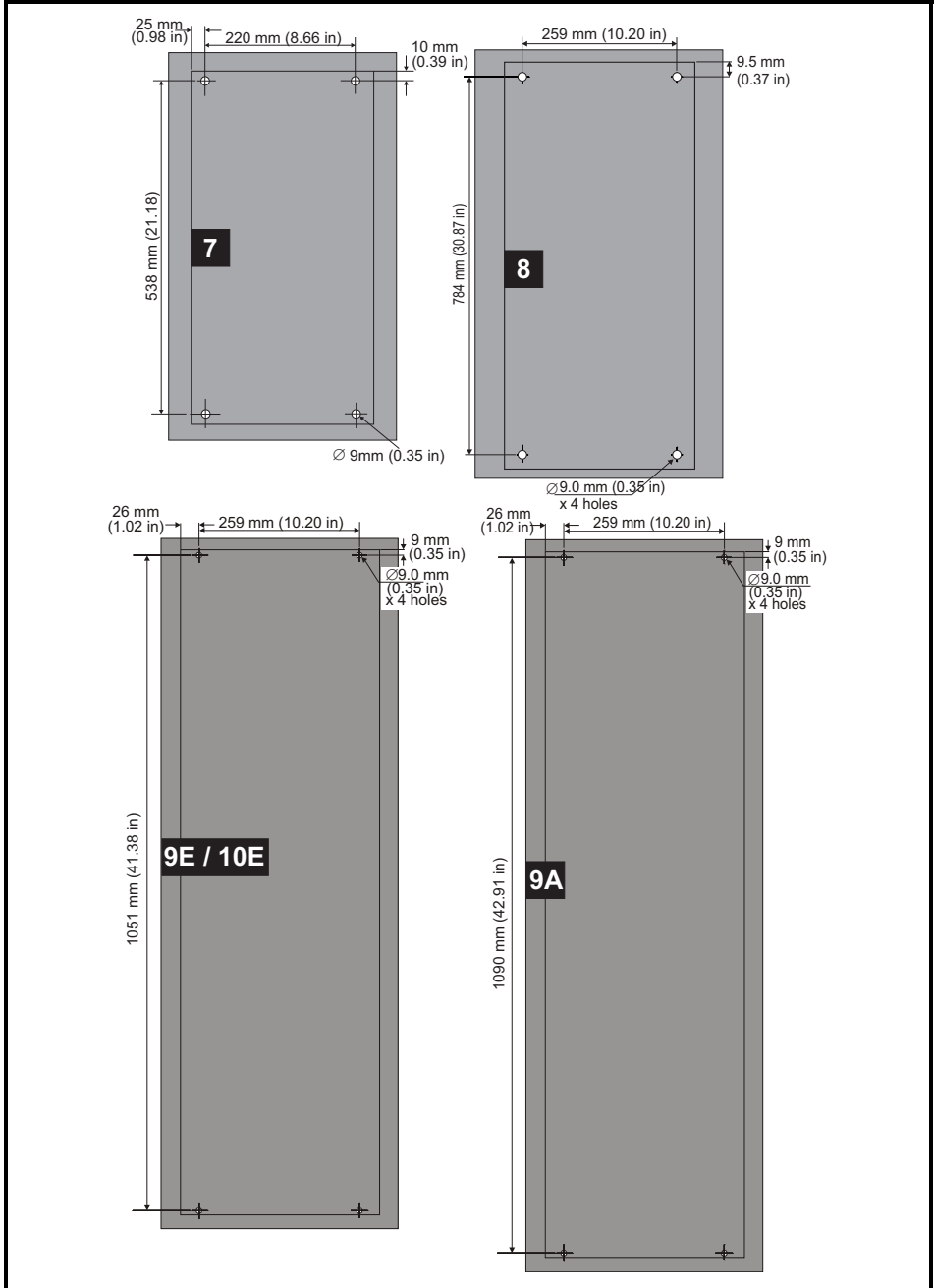

3.4.3 Through-panel mounting





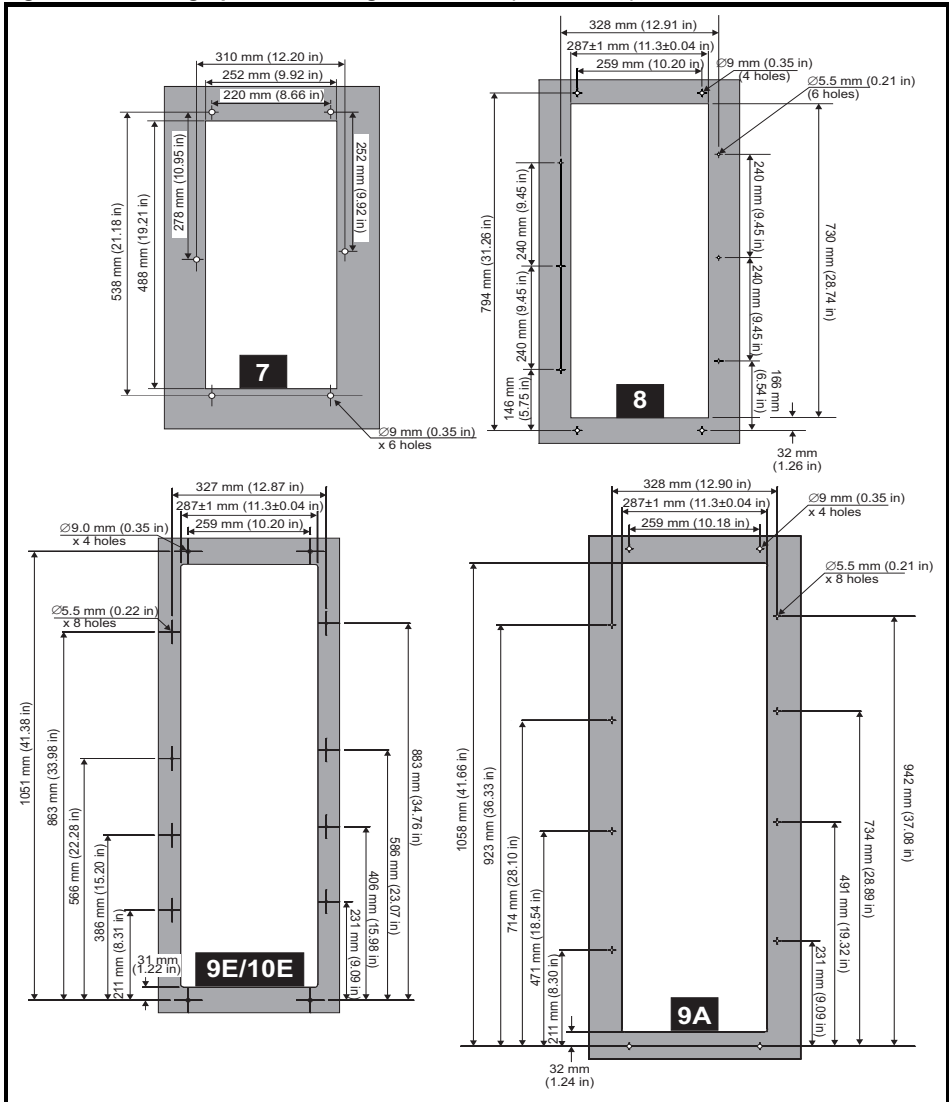



The drive can be through panel mounted using appropriate brackets.

Figure 3-8 Through-panel mounting dimensions (size 7 to 10)

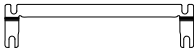

3.4.4 Mounting brackets

Table 3-2 Mounting brackets

Frame size	Surface mounting kit (supplied with drive)	Qty	Optional through-panel mounting kit	Qty
7	 Hole size: 9 mm (0.35 in)	x 2*	 Hole size: 9 mm (0.35 in)	x 2
				x 1
8	 Hole size: 9 mm (0.35 in)	x 2*	 Hole size: 5.5 mm (0.22 in)	x 6
				x 1
9A / 9E and 10E	 Hole size: 9 mm (0.35 in)	x 2*	 Hole size: 5.5 mm (0.22 in)	x 8
				x 1

* Surface mounting bracket are also used when through-panel mounting.

The through panel mounting kit is not supplied with the drive and can be purchased separately, below are the relevant part numbers:

Size	CT part number
7	3470-0079
8	3470-0083
9A	3470-0119
9E/10E	3470-0105



If the drive has been used at high load levels for a period of time, the heatsink can reach temperatures in excess of 70 °C (158 °F). Human contact with the heatsink should be prevented.

3.5 Enclosure for standard drives

3.5.1 Recommended spacing between the drives

Figure 3-9 Recommended spacing between the drives

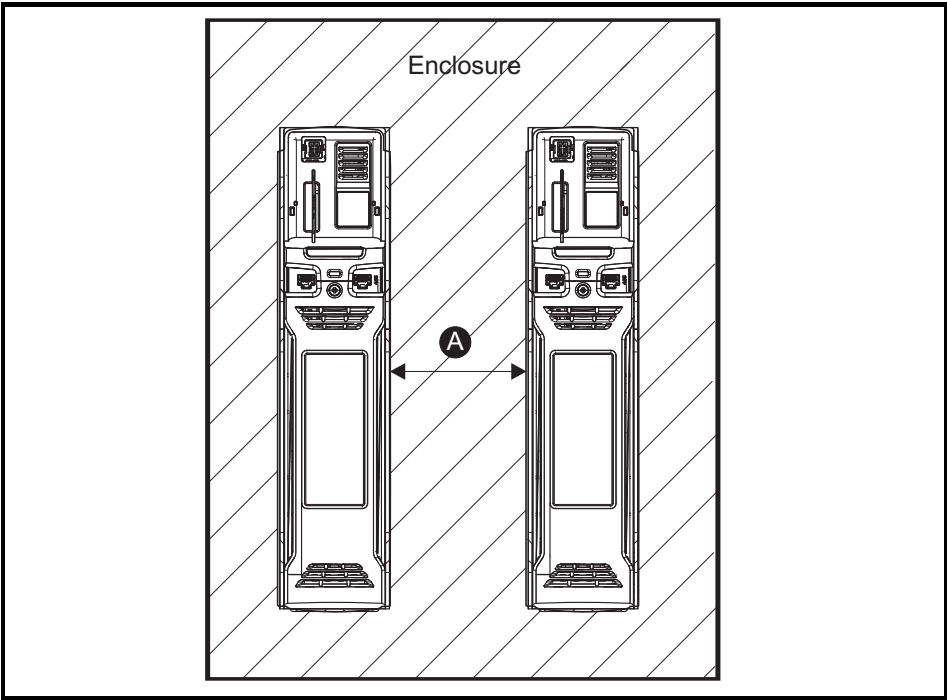

Table 3-3 Spacing required between the drives

Drive Size	Spacing (A)	
	40°C	50°C*
7	30 mm (1.18 in)	
8	30 mm (1.18 in)	
9A/E	60 mm (2.37 in)	
10E	60 mm (2.37 in)	

* 50°C derating applies, refer to Table 5-6 *Maximum permissible continuous output current @ 50 °C (122 °F)* on page 96.

NOTE When through-panel mounted, ideally drives should be spaced at least 45 mm (1.77 in) to maximize panel stiffness

3.5.2 Enclosure layout

Please observe the clearances in the diagram below taking into account any appropriate notes for other devices / auxiliary equipment when planning the installation.

Figure 3-10 Enclosure layout (size 7 to 8)

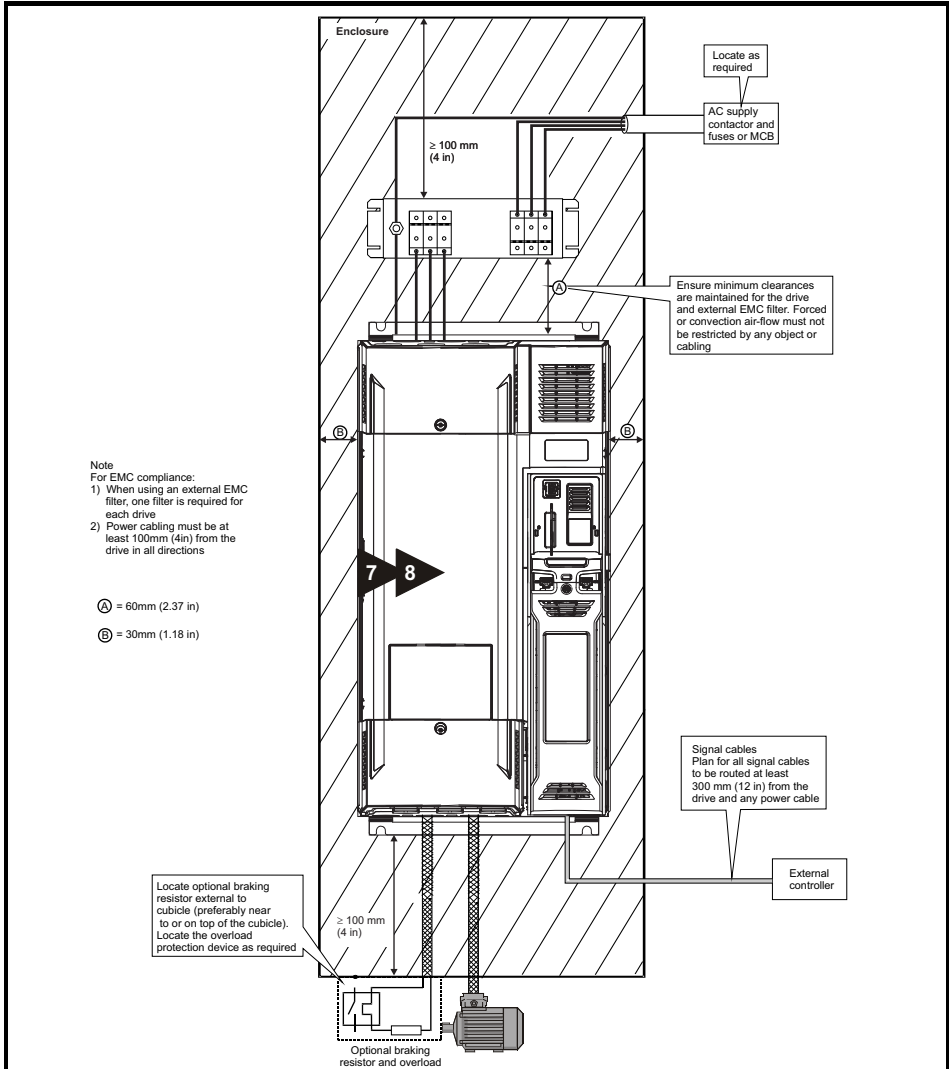

NOTE For EMC compliance:

1. When using an external EMC filter, one filter is required for each drive.
2. Power cabling must be at least 100 mm (4 in) from the drive in all directions

Figure 3-11 Enclosure layout (size 9 to 10)

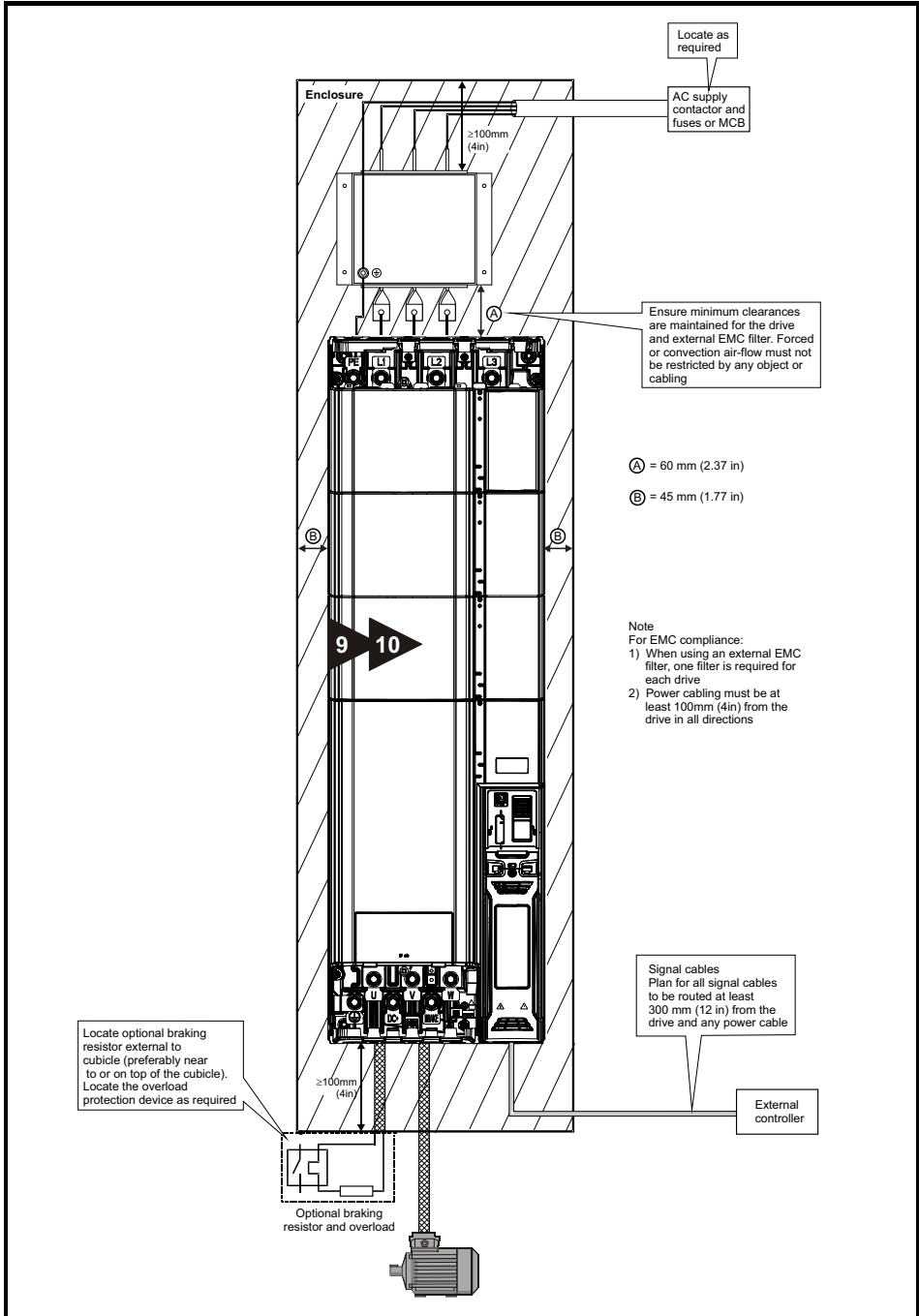

3.5.3 Enclosure sizing

1. Add the dissipation figures from section 5.1.3 *Power dissipation* on page 98 for each drive that is to be installed in the enclosure.
2. If an external EMC filter is to be used with each drive, add the dissipation figures from section 3.9.2 *EMC filter ratings* on page 44 for each external EMC filter that is to be installed in the enclosure.
3. If the braking resistor is to be mounted inside the enclosure, add the average power figures from for each braking resistor that is to be installed in the enclosure.
4. Calculate the total heat dissipation (in Watts) of any other equipment to be installed in the enclosure.
5. Add the heat dissipation figures obtained above. This gives a figure in Watts for the total heat that will be dissipated inside the enclosure.

Calculating the size of a sealed enclosure

The enclosure transfers internally generated heat into the surrounding air by natural convection (or external forced air flow); the greater the surface area of the enclosure walls, the better is the dissipation capability. Only the surfaces of the enclosure that are unobstructed (not in contact with a wall or floor) can dissipate heat.

Calculate the minimum required unobstructed surface area A_e for the enclosure from:

$$A_e = \frac{P}{k(T_{int} - T_{ext})}$$

Where:

- A_e Unobstructed surface area in m^2 ($1 m^2 = 10.9 ft^2$)
- T_{ext} Maximum expected temperature in $^{\circ}C$ *outside* the enclosure
- T_{int} Maximum permissible temperature in $^{\circ}C$ *inside* the enclosure
- P Power in Watts dissipated by *all* heat sources in the enclosure
- k Heat transmission coefficient of the enclosure material in $W/m^2/^{\circ}C$

Example

To calculate the size of an enclosure for the following:

- Two drives operating at the Normal Duty rating
- External EMC filter for each drive
- Braking resistors are to be mounted outside the enclosure
- Maximum ambient temperature inside the enclosure: $40^{\circ}C$
- Maximum ambient temperature outside the enclosure: $30^{\circ}C$

For example, if the power dissipation from each drive is 187 W and the power dissipation from each external EMC filter is 9.2 W.

Total dissipation: $2 \times (187 + 9.2) = 392.4 W$

NOTE

Power dissipation for the drives and the external EMC filters can be obtained from Chapter 5 *Technical data* on page 92.

The enclosure is to be made from painted 2 mm (0.079 in) sheet steel having a heat transmission coefficient of $5.5 W/m^2/^{\circ}C$. Only the top, front, and two sides of the enclosure are free to dissipate heat.

The value of $5.5 W/m^2/^{\circ}C$ can generally be used with a sheet steel enclosure (exact values can be obtained by the supplier of the material). If in any doubt, allow for a greater margin in the temperature rise.

Figure 3-12 Enclosure having front, sides and top panels free to dissipate heat

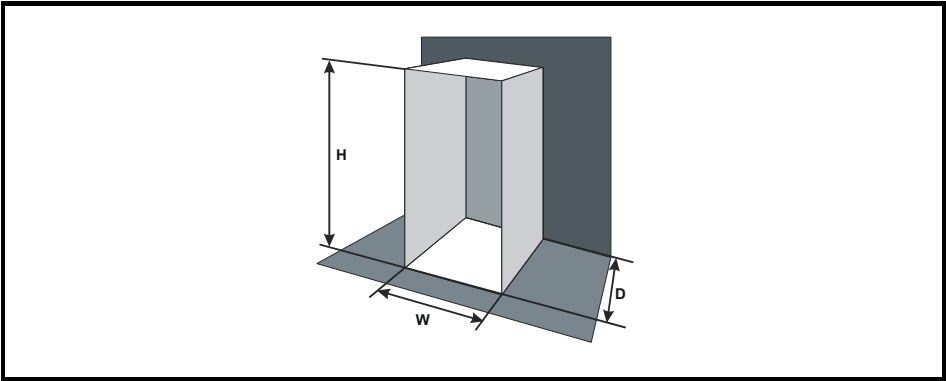

Insert the following values:

T_{int}	40 °C
T_{ext}	30 °C
k	5.5
P	392.4 W

The minimum required heat conducting area is then:

$$A_e = \frac{392.4}{5.5(40 - 30)}$$

$$= 7.135 \text{ m}^2 \text{ (77.8 ft}^2\text{)} \text{ (1 m}^2\text{ = 10.9 ft}^2\text{)}$$

Estimate two of the enclosure dimensions - the height (H) and depth (D), for instance. Calculate the width (W) from:

$$W = \frac{A_e - 2HD}{H + D}$$

Inserting $H = 2 \text{ m}$ and $D = 0.6 \text{ m}$, obtain the minimum width:

$$W = \frac{7.135 - (2 \times 2 \times 0.6)}{2 + 0.6}$$

$$= 1.821 \text{ m (71.7 in)}$$

If the enclosure is too large for the space available, it can be made smaller only by attending to one or all of the following:

- Using a lower PWM switching frequency to reduce the dissipation in the drives
- Reducing the ambient temperature outside the enclosure, and/or applying forced-air cooling to the outside of the enclosure
- Reducing the number of drives in the enclosure
- Removing other heat-generating equipment

Calculating the air-flow in a ventilated enclosure

The dimensions of the enclosure are required only for accommodating the equipment. The equipment is cooled by the forced air flow.

Calculate the minimum required volume of ventilating air from:

$$V = \frac{3kP}{T_{int} - T_{ext}}$$

Where:

V	Air-flow in m ³ per hour (1 m ³ /hr = 0.59 ft ³ /min)
T_{ext}	Maximum expected temperature in °C <i>outside</i> the enclosure
T_{int}	Maximum permissible temperature in °C <i>inside</i> the enclosure
P	Power in Watts dissipated by <i>all</i> heat sources in the enclosure
k	Ratio of $\frac{P_0}{P_1}$

Where:

P₀ is the air pressure at sea level

P₁ is the air pressure at the installation

Typically use a factor of 1.2 to 1.3, to allow also for pressure-drops in dirty air-filters.

Example

To calculate the size of an enclosure for the following:

- Three drives operating at the Normal Duty rating
- External EMC filter for each drive
- Braking resistors are to be mounted outside the enclosure
- Maximum ambient temperature inside the enclosure: 40 °C
- Maximum ambient temperature outside the enclosure: 30 °C

For example, dissipation of each drive: 101 W and dissipation of each external EMC filter: 6.9 W (max).

Total dissipation: 3 x (101 + 6.9) = 323.7 W

Insert the following values:

T_{int}	40 °C
T_{ext}	30 °C
k	1.3
P	323.7 W

Then:

$$V = \frac{3 \times 1.3 \times 323.7}{40 - 30}$$

$$= 126.2 \text{ m}^3/\text{hr} \text{ (74.5 ft}^3/\text{min)} \quad (1 \text{ m}^3/\text{hr} = 0.59 \text{ ft}^3/\text{min)}$$

3.6 Enclosure design and drive ambient temperature

Drive derating is required for operation in high ambient temperatures

Totally enclosing or through panel mounting the drive in either a sealed cabinet (no airflow) or in a well ventilated cabinet makes a significant difference on drive cooling.

The chosen method affects the ambient temperature value (T_{rate}) which should be used for any necessary derating to ensure sufficient cooling for the whole of the drive.

The ambient temperature for the four different combinations is defined below:

1. Totally enclosed with no air flow (<2 m/s) over the drive
 $T_{rate} = T_{int} + 5\text{ }^{\circ}\text{C}$
2. Totally enclosed with air flow (>2 m/s) over the drive
 $T_{rate} = T_{int}$
3. Through panel mounted with no airflow (<2 m/s) over the drive
 $T_{rate} = \text{the greater of } T_{ext} + 5\text{ }^{\circ}\text{C}, \text{ or } T_{int}$
4. Through panel mounted with air flow (>2 m/s) over the drive
 $T_{rate} = \text{the greater of } T_{ext} \text{ or } T_{int}$

Where:

T_{ext} = Temperature outside the cabinet

T_{int} = Temperature inside the cabinet

T_{rate} = Temperature used to select current rating from tables in Chapter 5 *Technical data* on page 92.

3.7 Heatsink fan operation

The drive is ventilated by an internal heatsink mounted fan. The fan housing forms a baffle plate, channelling the air through the heatsink chamber. Thus, regardless of mounting method (surface mounting or through-panel mounting), the installing of additional baffle plates is not required.

Ensure the minimum clearances around the drive are maintained to allow air to flow freely.

The heatsink fan on all sizes is a variable speed fan. The drive controls the speed at which the fan runs based on the temperature of the heatsink and the drive's thermal model system. The maximum speed at which the fan operates can be limited in Pr **06.045**. This could incur an output current derating. Size 7 to 10 are also fitted with a variable speed fan to ventilate the capacitor bank. Refer to section 3.11 *Routine maintenance* on page 49 for information on fan removal.

3.8 Enclosing standard drive for high environmental protection

An explanation of environmental protection rating is provided in section 5.1.9 *IP / UL Rating* on page 102.

The standard drive is rated to IP20 pollution degree 2 (dry, non-conductive contamination only) (NEMA 1). However, it is possible to configure the drive to achieve IP65 rating (size 7 and 8) or IP55 (size 9 and 10) (NEMA 12) at the rear of the heatsink for through-panel mounting.

This allows the front of the drive, along with various switchgear, to be housed in a high IP enclosure with the heatsink protruding through the panel to the external environment. Thus, the majority of the heat generated by the drive is dissipated outside the enclosure maintaining a reduced temperature inside the enclosure. This also relies on a good seal being made between the heatsink and the rear of the enclosure using the gasket and securing brackets provided.

The main gasket should be installed as shown in Figure 3-13.

Figure 3-13 Installing the gasket

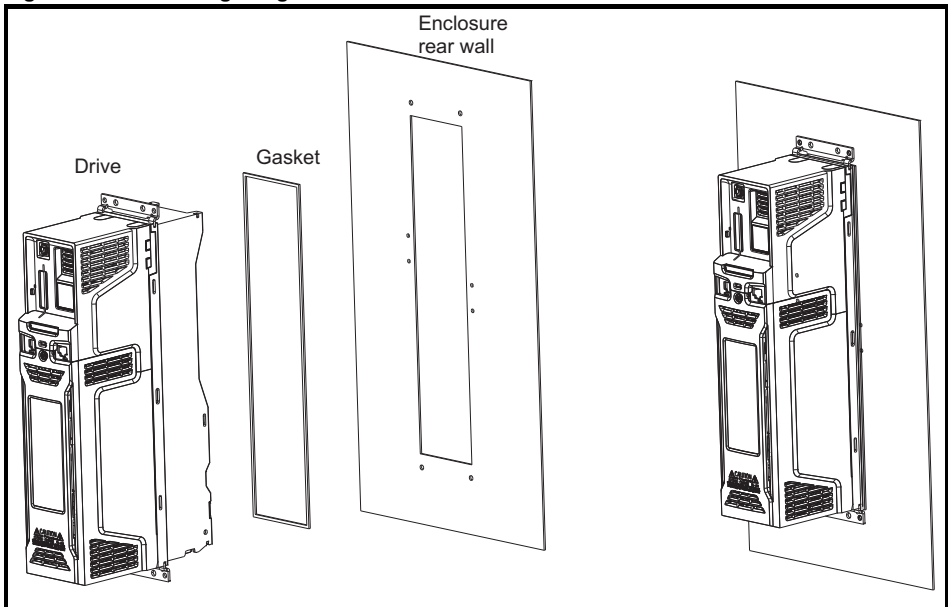

A special procedure is necessary when through hole mounting size 7 in a high IP enclosure to move an EMC bracket that would otherwise prevent a good seal. This procedure is described in Figure 3-14.

Figure 3-14 Special procedure for size 7 only

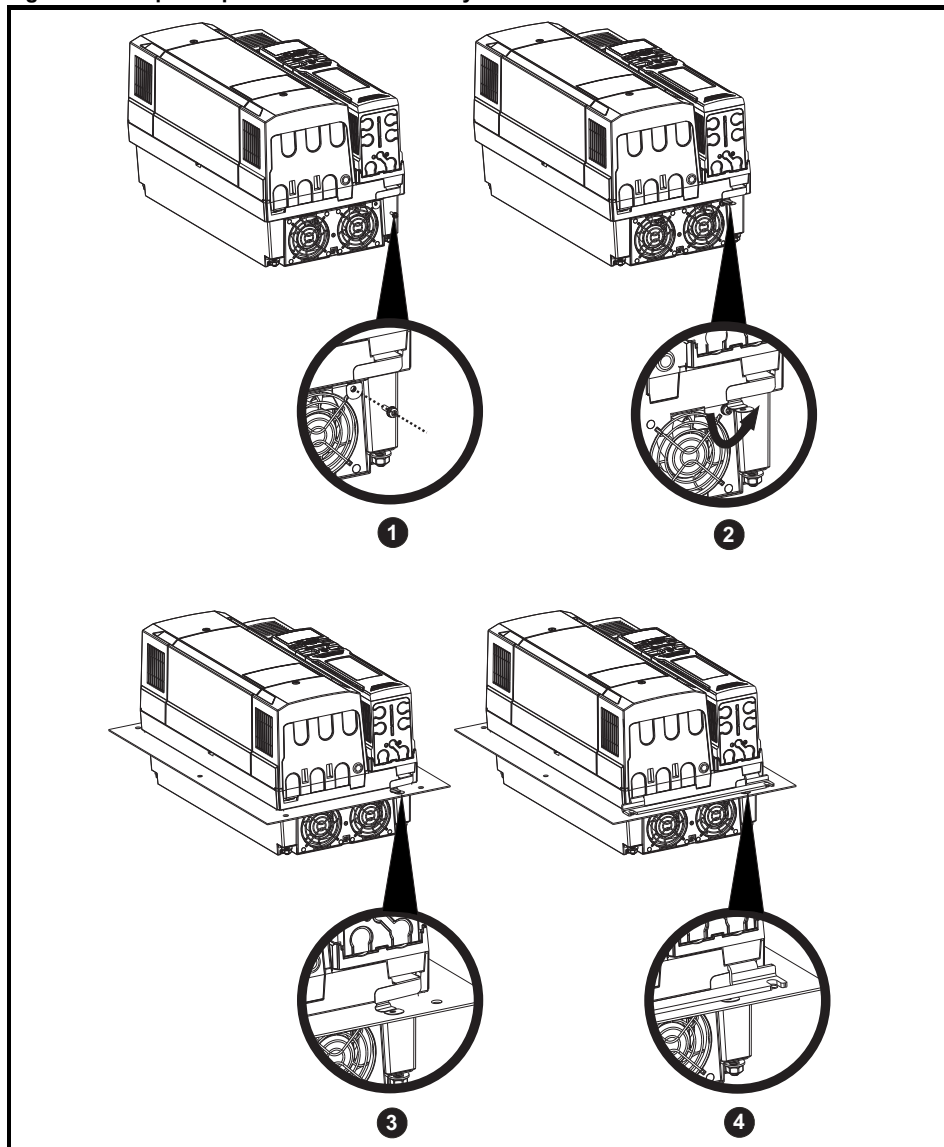

- 1) Remove screw shown using T20 torque driver
- 2) Bend EMC bracket 90 degrees as shown
- 3) Fit sealing gasket and place drive in panel cutout
- 4) Ensure EMC bracket is trapped under lower mounting bracket when fitting brackets

Figure 3-15 Example of high IP through-panel layout

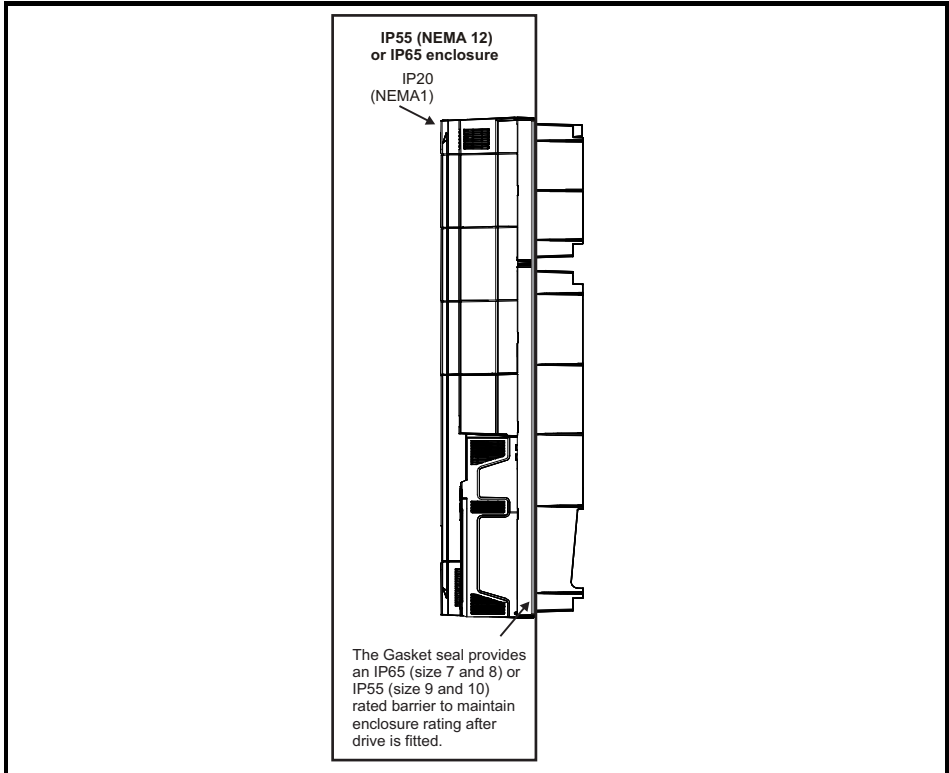

The main gasket should be installed as shown in Figure 3-13. Any screws / bolts that are used for mounting should be installed with M8 flat nylon washers to maintain a seal around the screw hole. See Figure 3-16 on page 42, sealing clamps are supplied in the through panel mounting kit to aid compression of the gasket.

NOTE

The heatsink fans have conformal coated PCBs and have sealant at cable entry points. Dripping, splashing or sprayed water can impede the operation of the fan, therefore if the environment is such that the fan may be subjected to more than occasional dripping or sprayed water while operational, then suitable drip protection covers should be employed.

Figure 3-16 View showing sealing clamps provided in through hole mounting kit

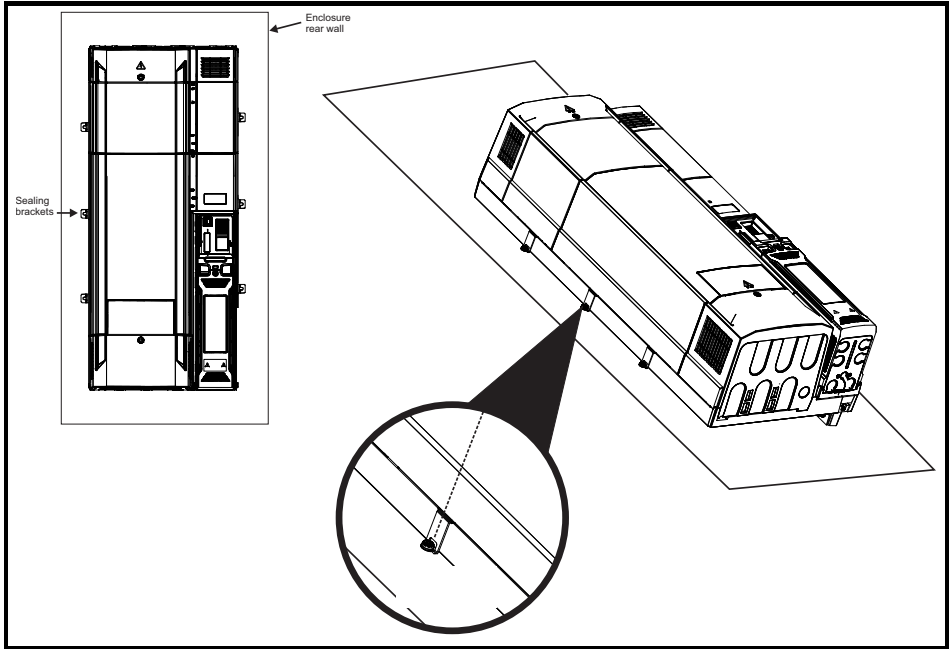

NOTE For detailed information regarding high IP through panel mounting see section 3.4.3 *Through-panel mounting* on page 30.

NOTE When designing a high IP enclosure, consideration should be given to the dissipation from the front of the drive.

Table 3-4 Power losses from the front of the drive when through-panel mounted

Frame size	Power loss
7	≤ 204 W
8	≤ 347 W
9A/9E/10E	≤ 480 W

3.9 External EMC filter

The external EMC filters for sizes 7 to 10, are designed to be mounted above the drive as shown below.

Figure 3-17 Size 7 to 10 mounting of the EMC filter

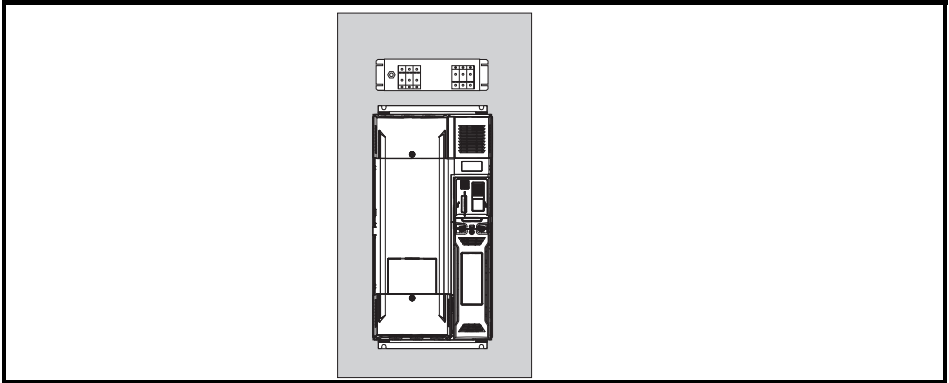

3.9.1 Optional external EMC filters

Table 3-5 EMC filter cross reference

Model	CT part number
200 V	
07200610 to 07200830	4200-1132
08201160 to 08201320	4200-1972
09201760 to 09202190 (9A)	4200-3021
09201760 to 09202190 (9E)	4200-4460
10202830 to 10203000	4200-4460
400 V	
07400660 to 07401000	4200-1132
08401340 to 08401570	4200-1972
09402000 to 09402240 (9A)	4200-3021
09402000 to 09402240 (9E)	4200-4460
10402700 to 10403200	4200-4460
575 V	
07500440 to 07500550	4200-0672
08500630 to 08500860	4200-1662
09501040 to 09501310 (9A)	4200-1660
09501040 to 09501310 (9E)	4200-2210
10501520 to 10501900	4200-2210
690 V	
07600190 to 07600540	4200-0672
08600630 to 08600860	4200-1662
09601040 to 09601310 (9A)	4200-1660
09601040 to 09601310 (9E)	4200-2210
10601500 to 10601780	4200-2210

3.9.2 EMC filter ratings

Table 3-6 Optional external EMC filter details

CT part number	Maximum continuous current		Voltage rating		IP rating	Power dissipation at rated current		Ground leakage		Discharge resistors
	@ 40 °C (104 °F)	@ 50 °C (122 °F)	IEC	UL		@ 40 °C (104 °F)	@ 50 °C (122 °F)	Balanced supply phase-to-phase and phase-to-ground	Worst case	
	A	A	V	V		W	W	mA	mA	
4200-1132	117	102.7*	528	480	20	50	43.7	11.7	188	1.68
4200-0672	67	58.8*	759	600		25	21.9	24.5	395	2.72
4200-1972	197	172.8*	528	480		42	36.7	18.7	210	1.68
4200-1662	114	100*	759	600		39	34.1	24.3	364	2.72
4200-3021	302	277	528	480	00	34	29.7	30	202	1.68
4200-1660	166	152	759	600		13	11.4	21	332	2.72
4200-4460	446	409	528	480		37	32.4	30	283	1.68
4200-2210	221	203	759	600		16	14.0	21	434	2.72

* At 55 °C (131 °F).

3.9.3 Overall EMC filter dimensions

Table 3-7 Optional external EMC filter dimensions

Part Number	Dimensions (mm)						Weight	
	H		W		D		kg	lb
	mm	inch	mm	inch	mm	inch		
4200-1132	270	10.63	90	3.54	150	5.90	6	13.2
4200-0672	270	10.63	90	3.54	150	5.90	6.2	13.7
4200-1972	300	11.81	120	4.72	170	6.69	9.6	21.2
4200-1662	300	11.81	120	4.72	170	6.69	9.4	20.7
4200-3021	339	13.3	230	9.06	120	4.72	11	24.3
4200-1660	360	14.2	245	9.6	105	4.13	5.2	11.5
4200-4460	105	4.13	360	14.2	245	9.6	12	26.5
4200-2210	105	4.13	360	14.2	245	9.6	10.3	22.7

Figure 3-18 External EMC filter (size 7 to 8)

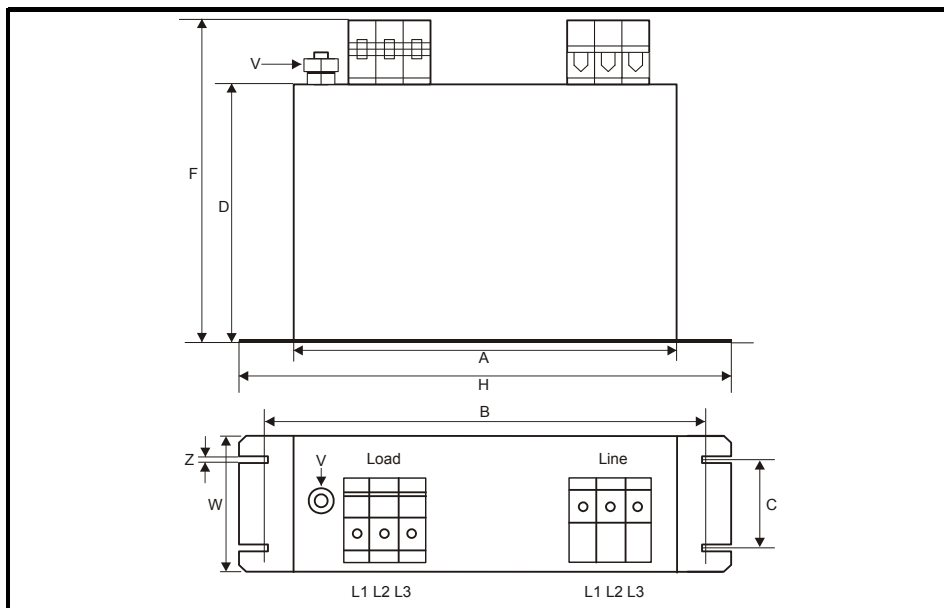

Table 3-8 Size 7 external EMC filter dimensions

CT part number	A	B	C	D	E	F	H	W	V	X	Y	Z
4200-1132	240 mm	255 mm	55 mm	150 mm		205 mm	270 mm	90 mm	M10			6.5 mm
4200-0672	(9.45 in)	(10.04 in)	(2.17 in)	(5.90 in)		(8.07 in)	(10.63 in)	(3.54 in)				(0.26 in)

Table 3-9 Size 8 external EMC filter dimensions

CT part number	A	B	C	D	E	F	H	W	V	X	Y	Z
4200-1972	260 mm	275 mm	85 mm	170 mm		249 mm	300 mm	120 mm	M10			6.5 mm
4200-1662	(10.24 in)	(10.83 in)	(3.35 in)	(6.69 in)		(9.79 in)	(11.81 in)	(4.72 in)				(10.26 in)

Figure 3-19 External EMC filter (size 9A)

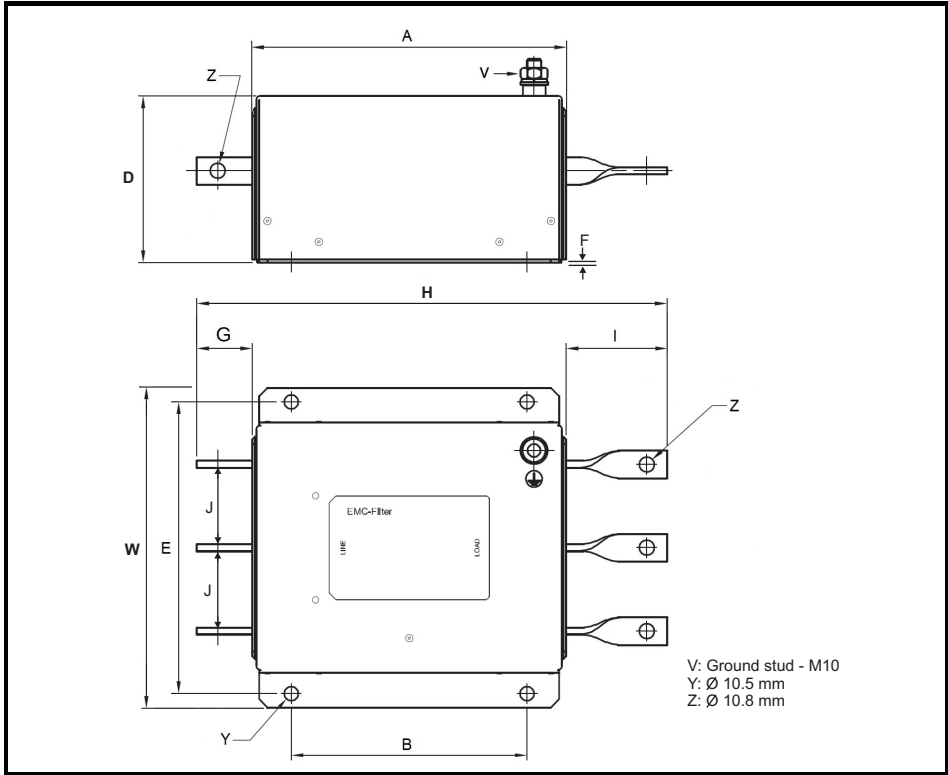

Table 3-10 Size 9A external EMC filter dimensions

CT part number	A	B	D	E	F	G	H	I	J	W
4200-3021	220 mm (8.66 in)	170 mm (6.70 in)	120 mm (4.72 in)	210 mm (8.27 in)	2 mm (0.08 in)	40 mm (1.57 in)	339 mm (13.34)	73 mm (2.87 in)	60 mm (2.36 in)	230 mm (9.06 in)
4200-1660	280 mm (11.02 in)	180 mm (7.09 in)	105 mm (4.13 in)	225 mm (8.86 in)	2 mm (0.08 in)	40 mm (1.57 in)	360 mm (14.17 in)	73 mm (2.87 in)	60 mm (2.36 in)	245 mm (9.65 in)

Figure 3-20 External EMC filter (size 9E and 10E)

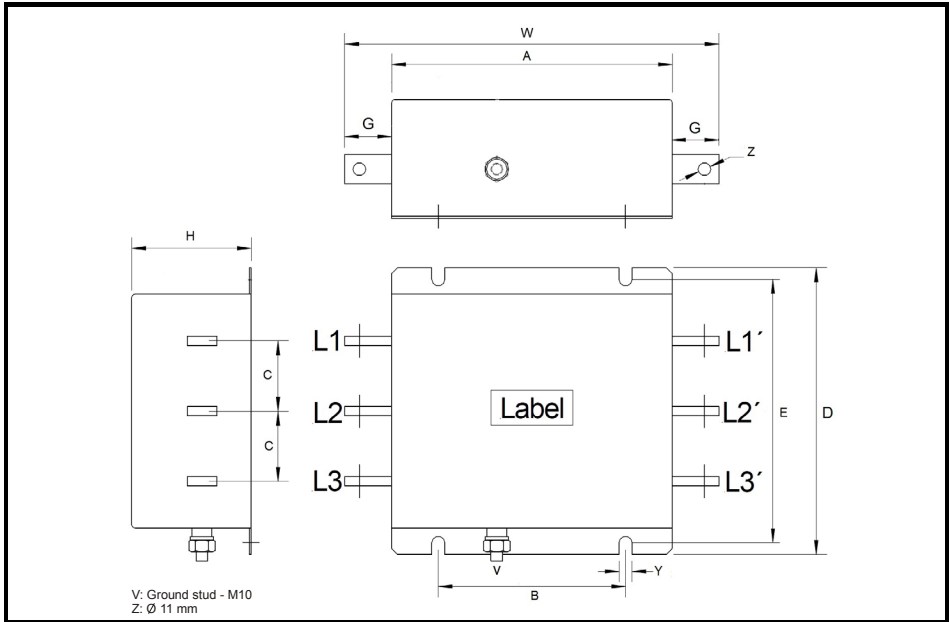

Table 3-11 Size 9E and 10E external EMC filter dimensions

CT part number	A	B	C	D	E	G	H	W	Y
4200-4460	280 mm	180 mm	57 mm	245 mm	225 mm	40 mm	105 mm	360 mm	11 mm
4200-2210	(11.02)	(7.09)	(2.24 mm)	(9.65 in)	(8.86 in)	(1.57 in)	(4.13 in)	(14.7 in)	(0.43 in)

3.9.4 EMC filter torque settings

Table 3-12 Optional external EMC Filter terminal data.

CT part number	Power connections			Ground connections	
	Bar hole diameter	Max cable size	Max torque	Ground stud size	Max torque
4200-1132	N/A	50 mm ² (1/0 AWG)	8.0 N m (6.0 lb ft)	M10	18 N m (13.3 lb ft)
4200-0672					
4200-1972		95 mm ² (3/0 AWG)	20 N m (14.8 lb ft)		
4200-1662					
4200-3021	10.8 mm	N/A	30 N m (22.1 lb ft)		
4200-1660					
4200-4460				11 mm	
4200-2210				11 mm	

3.10 Terminal size and torque settings

Table 3-13 Drive control terminal data

Model	Connection type	Torque setting
M200 to M400	Screw terminals	0.2 N m (0.15 lb ft)
M600 to M702	Plug-in terminal block	0.5 N m (0.4 lb ft)

Table 3-14 Drive relay terminal data

Model	Connection type	Torque setting
M200 to M400	Screw terminals	0.5 N m (0.4 lb ft)
M600 to M702	Plug-in terminal block	

Table 3-15 Terminal block maximum cable sizes

Model	Size	Terminal block description	Maximum cable size
All	All	Control connector	1.5 mm ² (16 AWG)
All	All	2 way relay connector	2.5 mm ² (14 AWG)
M300 to M400	7 to 9	STO connector	
M600 to M702	All	2 way low voltage power 24V supply connector	1.5 mm ² (16 AWG)

Table 3-16 Maximum crimp/lug sizes for frame size 8 to 10

Terminals	Maximum standard crimp (mm ²)	Maximum standard US lug (kcmil)
AC supply connections	2 x 185	2 x 500
AC supply ground	2 x 120	1 x 350
Motor connections	2 x 150	2 x 350
Drive output ground	2 x 150	1 x 350
Brake connection	2 x 150	2 x 350

Table 3-17 Drive power terminal data

Model size	AC and motor terminals		DC and braking		Ground terminal	
	Recommended	Maximum	Recommended	Maximum	Recommended	Maximum
7	M8 Nut (13 mm AF)		M8 Nut (13 mm AF)		M8 Nut (13 mm AF)	
	12 N m (8.85 lb ft)	14 N m (10 lb ft)	12 N m (8.85 lb ft)	14 N m (10 lb ft)	12 N m (8.85 lb ft)	14 N m (10 lb ft)
8 to 10	M10 Nut (17 mm AF)		M10 Nut (17 mm AF)		M10 Nut (17 mm AF)	
	15 N m (11.1 lb ft)	20 N m (14.8 lb ft)	15 N m (11.1 lb ft)	20 N m (14.8 lb ft)	15 N m (11.1 lb ft)	20 N m (14.8 lb ft)

3.11 Routine maintenance

The drive should be installed in a cool, clean, well ventilated location. Contact of moisture and dust with the drive should be prevented.

Regular checks of the following should be carried out to ensure drive / installation reliability are maximized:

Environment	
Ambient temperature	Ensure the enclosure temperature remains at or below maximum specified
Dust	Ensure the drive remains dust free – check that the heatsink and drive fan are not gathering dust. The lifetime of the fan is reduced in dusty environments.
Moisture	Ensure the drive enclosure shows no signs of condensation
Enclosure	
Enclosure door filters	Ensure filters are not blocked and that air is free to flow
Electrical	
Screw connections	Ensure all screw terminals remain tight
Crimp terminals	Ensure all crimp terminals remains tight – check for any discoloration which could indicate overheating
Cables	Check all cables for signs of damage

3.11.1 Size 7 heatsink fan replacement

Figure 3-21 Size 7 heatsink fan replacement

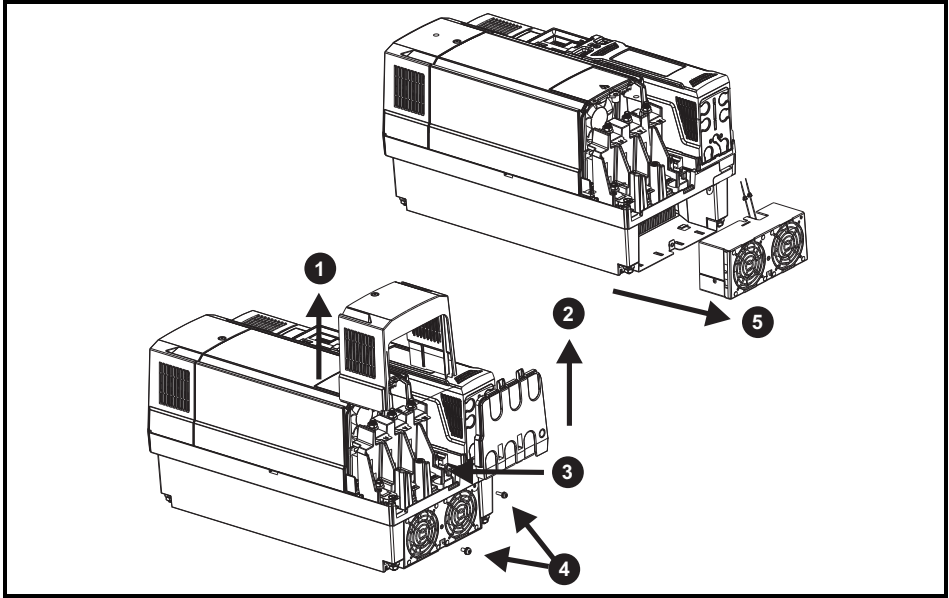

Size 7 heatsink fan removal procedure

- 1) Remove terminal cover
 - 2) Remove finger guard
 - 3) Disconnect fan cables from drive (making a note of the order) and push grommets down prior to attempting fan removal
 - 4) Remove the mounting screws using a T20 and T25 torque driver
 - 5) Withdraw fan housing from the drive
- After fan(s) have been replaced, reverse the above steps to refit.

Table 3-18 Size 7 heatsink fan part number

Drive model	Heatsink fan part number
Size 7	3251-8247

3.11.2 Size 8 heatsink fan replacement

Figure 3-22 Size 8 heatsink fan replacement

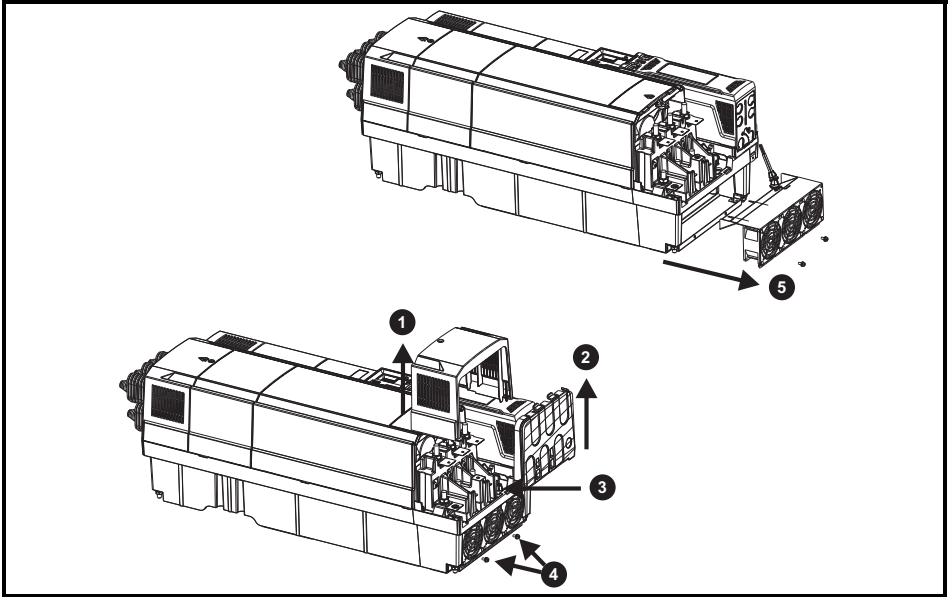

Size 8 heatsink fan removal procedure

- 1) Remove terminal cover
- 2) Remove finger guard
- 3) Disconnect fan cables from drive (making a note of the order) and push grommet down prior to attempting fan removal
- 4) Remove the mounting screws using a T20 torque driver
- 5) Withdraw fan housing from the drive

After fan(s) have been replaced, reverse the above steps to refit.

Table 3-19 Size 8 heatsink fan part number

Drive model	Heatsink fan part number
Size 8	3251-8240

3.11.3 Size 9 and 10 heatsink fan replacement

Figure 3-23 Size 9 and 10 heatsink fan replacement

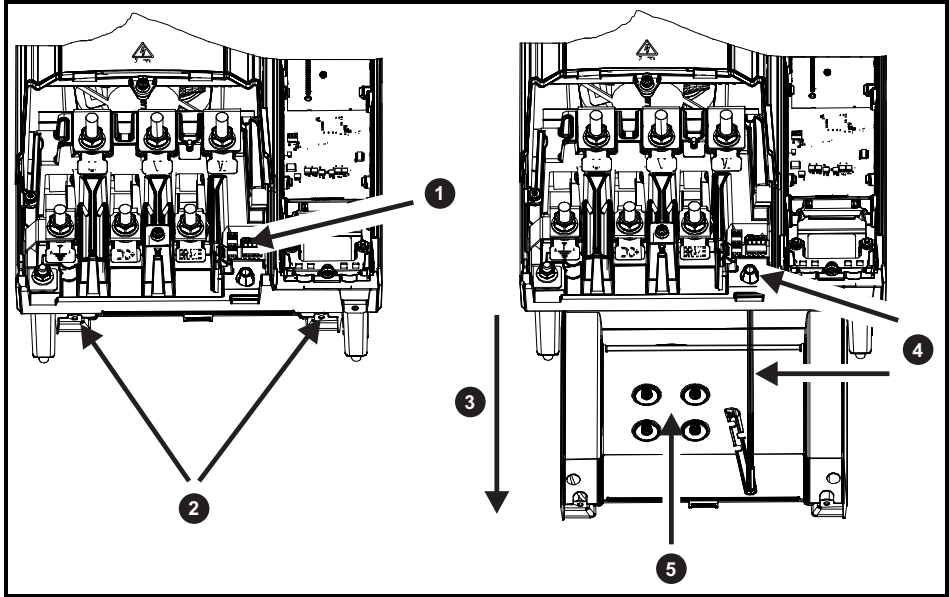

Heatsink fan removal procedure

- 1) Using a flat screwdriver remove the fan wires from the fan connector (making a note of the order).
 - 2) Using a T20 Torque driver remove the two screws that retain the heatsink fan housing
 - 3) Withdraw the heatsink fan housing from the drive in the direction shown
 - 4) Pull the fan cable through the fan cable gland
 - 5) Using a T20 Torque driver remove the four screws that retain the fan in the housing
- After fan has been replaced, reverse the above steps to refit.

Table 3-20 Size 9 and 10 heatsink fan part number

Drive model	Heatsink fan part number
Size 9 and 10	3251-1750

3.11.4 Size 7 to 10 auxiliary (capacitor bank) fan replacement

Figure 3-24 Size 7 to 10 auxiliary (capacitor bank) fan replacement

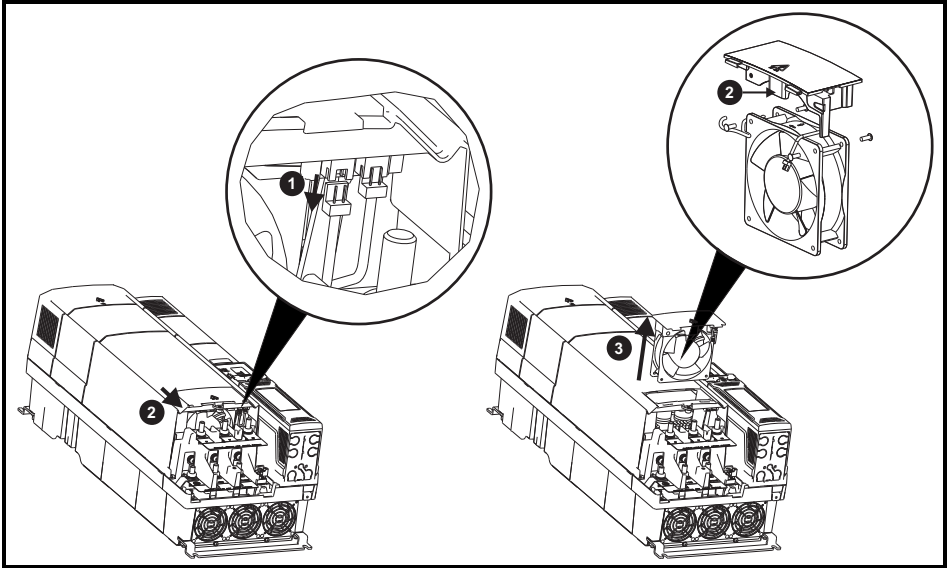

Auxiliary fan removal procedure

- 1) Disconnect fan wiring connector shown
- 2) Slide fan housing in the direction shown using tongue shown in enlarged diagram of fan
- 3) Withdraw fan housing from the drive

After fan has been replaced, reverse the above steps to refit.

Table 3-21 Auxiliary (capacitor bank) fan part numbers

Drive model	Auxiliary (capacitor bank) fan part number
Size 7	3251-0041
Size 8	3251-2249
Size 9 to 10	3251-0042

4 Electrical installation



Electric shock risk

The voltages present in the following locations can cause severe electric shock and may be lethal:

- AC supply cables and connections
- DC and brake cables, and connections
- Output cables and connections

Many internal parts of the drive, and external option units

Unless otherwise indicated, control terminals are single insulated and must not be touched.



Isolation device

The AC and / or DC power supply must be disconnected from the drive using an approved isolation device before any cover is removed from the drive or before any servicing work is performed.



STOP function

The STOP function does not remove dangerous voltages from the drive, the motor or any external option units.



Safe Torque Off function

The Safe Torque Off function does not remove dangerous voltages from the drive, the motor or any external option units.



Stored charge

The drive contains capacitors that remain charged to a potentially lethal voltage after the AC and / or DC power supply has been disconnected. If the drive has been energized, the AC and / or DC power supply must be isolated at least ten minutes before work may continue. Normally, the capacitors are discharged by an internal resistor. Under certain, unusual fault conditions, it is possible that the capacitors may fail to discharge, or be prevented from being discharged by a voltage applied to the output terminals. If the drive has failed in a manner that causes the display to go blank immediately, it is possible the capacitors will not be discharged. In this case, consult Nidec Industrial Automation or their authorized distributor.



Equipment supplied by plug and socket

Special attention must be given if the drive is installed in equipment which is connected to the AC supply by a plug and socket. The AC supply terminals of the drive are connected to the internal capacitors through rectifier diodes which are not intended to give safety isolation. If the plug terminals can be touched when the plug is disconnected from the socket, a means of automatically isolating the plug from the drive must be used (e.g. a latching relay).



Permanent magnet motors

Permanent magnet motors generate electrical power if they are rotated, even when the supply to the drive is disconnected. If that happens then the drive will become energized through its motor terminals. If the motor load is capable of rotating the motor when the supply is disconnected, then the motor must be isolated from the drive before gaining access to any live parts.

4.1 Power and ground connections

Figure 4-1 Size 7 and 8 power and ground connections (size 7 shown)

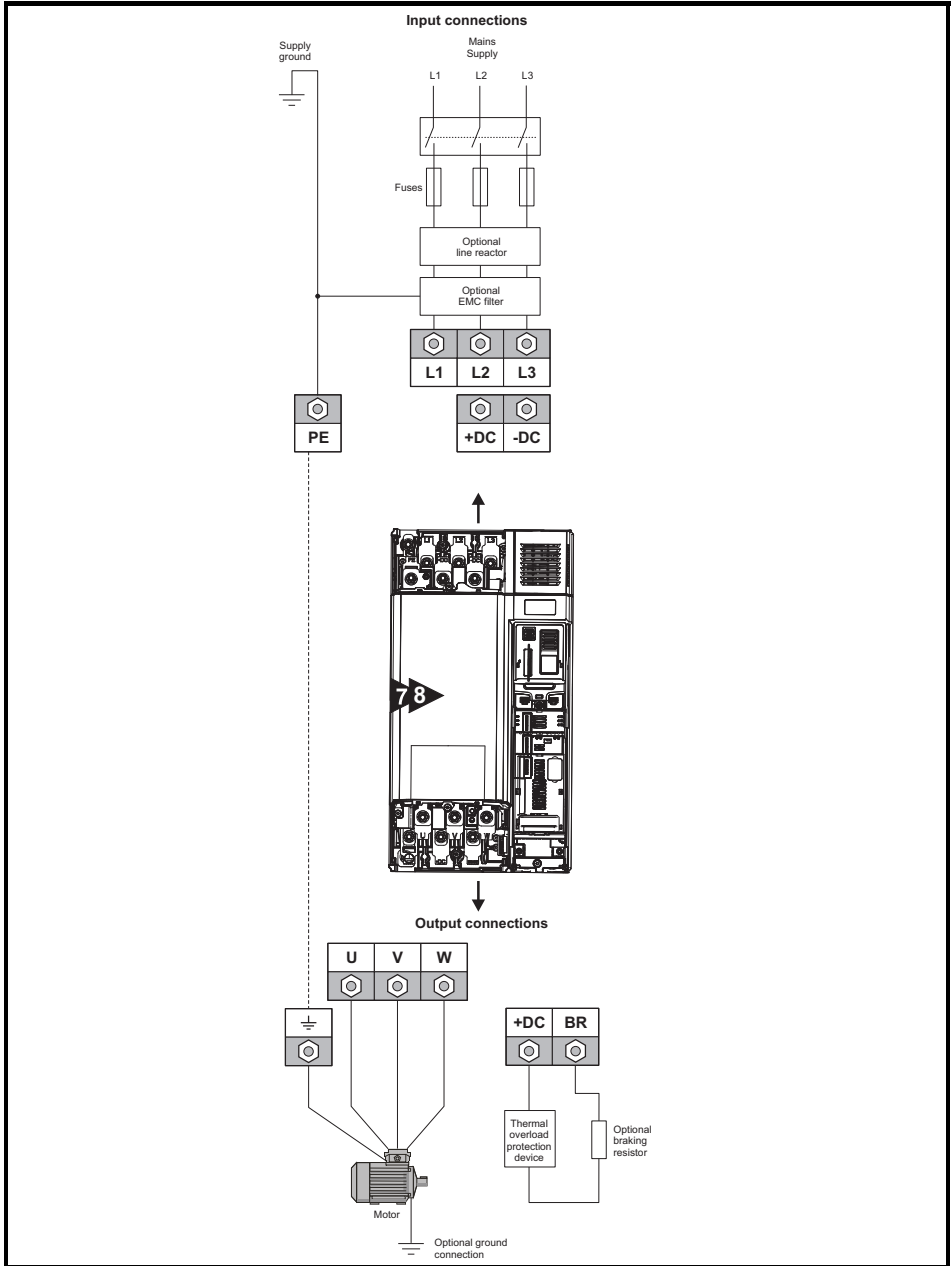

On size 7 and 8, the supply and motor ground connections are made using the M8 studs located by the supply and motor connection terminals. Refer to Figure 4-1.

Figure 4-2 Frame 9A power and ground connections

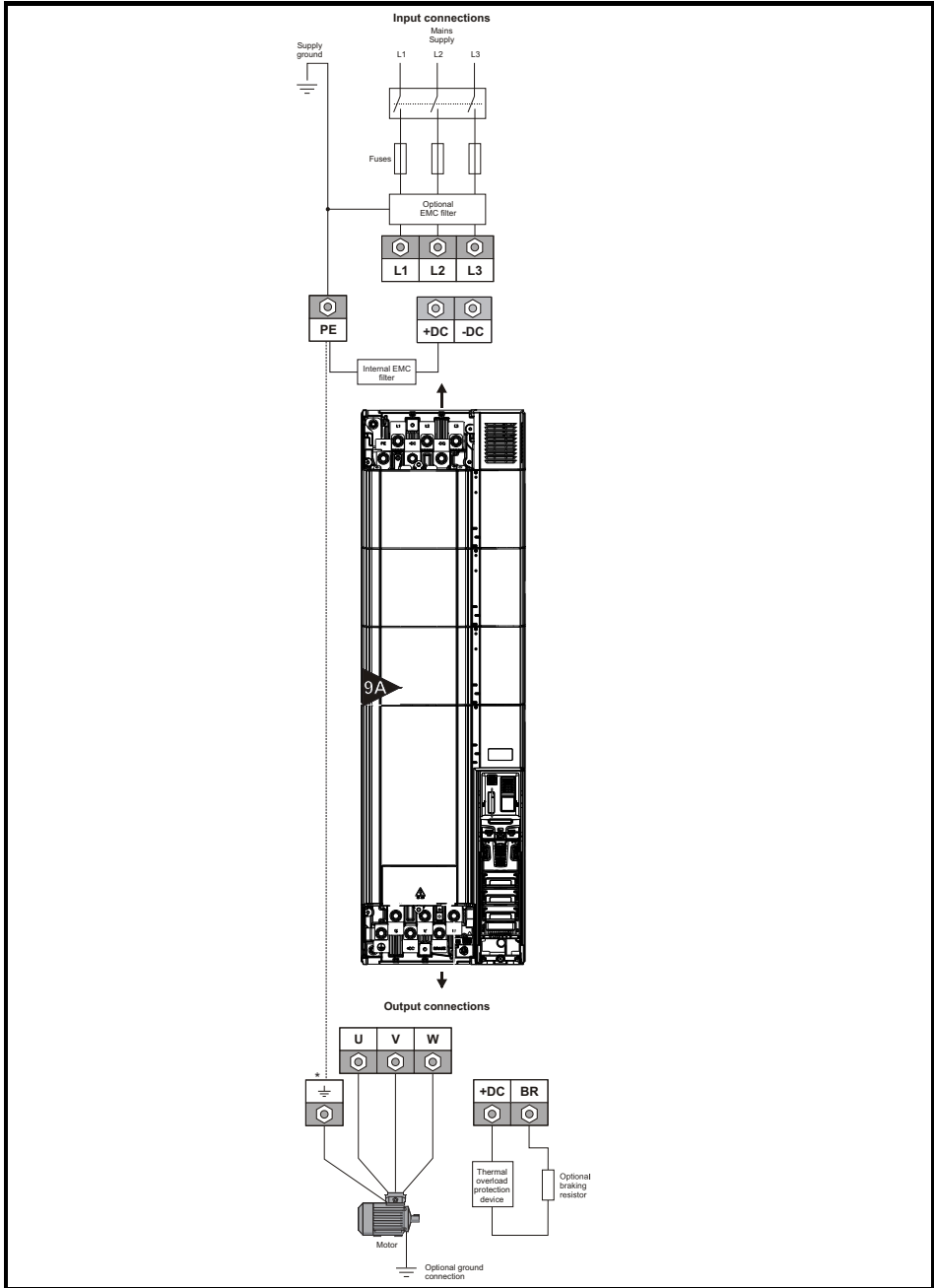

On size 9A, the supply and motor ground connections are made using the M10 studs located by the supply and motor connection terminals. Refer to Figure 4-2.

Figure 4-3 Size 9E and 10E power and ground connections

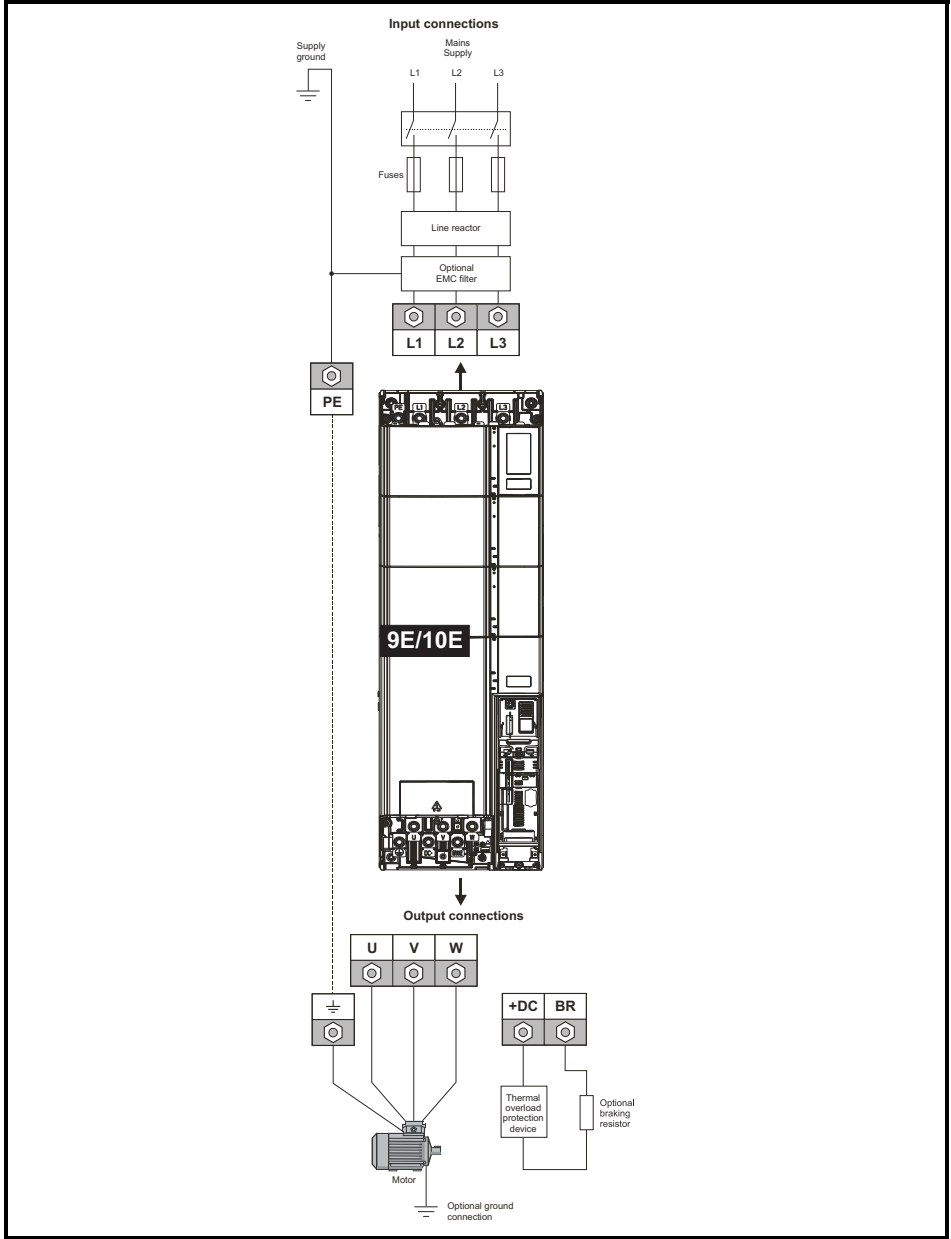

A separate line reactor (INLXXX) must be used for size 9E and 10E. Failure to provide sufficient reactance could damage or reduce the service life of the drive. Refer to Table 4-4 *Size 7 to 10 Model and Line reactor part number* on page 61.

4.1.1 Ground connections



Electrochemical corrosion of grounding terminals

Ensure that grounding terminals are protected against corrosion i.e. as could be caused by condensation.

The drive must be connected to the system ground of the AC supply. The ground wiring must conform to local regulations and codes of practice.

On size 9E and 10E, the supply and motor ground connections are made using the M10 studs located by the supply and motor connection terminals. Refer to Figure 4-3.



The ground loop impedance must conform to the requirements of local safety regulations.

The drive must be grounded by a connection capable of carrying the prospective fault current until the protective device (fuse, etc.) disconnects the AC supply.

The ground connections must be inspected and tested at appropriate intervals.

Table 4-1 Protective ground cable ratings

Input phase conductor size	Minimum ground conductor size
$\leq 10 \text{ mm}^2$	Either 10 mm^2 or two conductors of the same cross-sectional area as the input phase conductor
$> 10 \text{ mm}^2$ and $\leq 16 \text{ mm}^2$	The same cross-sectional area as the input phase conductor
$> 16 \text{ mm}^2$ and $\leq 35 \text{ mm}^2$	16 mm^2
$> 35 \text{ mm}^2$	Half of the cross-sectional area of the input phase conductor

4.2 AC Supply requirements

AC supply voltage:

200 V drive: 200 V to 240 V $\pm 10 \%$

400 V drive: 380 V to 480 V $\pm 10 \%$

575 V drive: 500 V to 575 V $\pm 10 \%$

690 V drive: 500 V to 690 V $\pm 10 \%$

Number of phases: 3

Maximum supply imbalance: 2 % negative phase sequence (equivalent to 3 % voltage imbalance between phases).

Frequency range: 45 to 66 Hz

For UL compliance only, the maximum supply symmetrical fault current must be limited to 100 kA

Table 4-2 Supply fault current used to calculate maximum input currents

Model	Symmetrical fault level (kA)
All	100

4.2.1 Supply types

All drives are suitable for use on any supply type i.e TN-S, TN-C-S, TT and IT.

Supplies with voltage up to 600 V may have grounding at any potential, i.e. neutral, centre or corner ("grounded delta") Supplies with voltage above 600 V may not have corner grounding



If an SI-Applications Plus module is installed in the drive, then the drive must not be used on a corner-grounded or centre-grounded delta supply if the supply voltage is above 300 V. If this is required, please contact the supplier of the drive for more information.

Drives are suitable for use on supplies of installation category III and lower, according to IEC 60664-1. This means they may be connected permanently to the supply at its origin in a building, but for outdoor installation additional over-voltage suppression (transient voltage surge suppression) must be provided to reduce category IV to category III.



Operation with IT (ungrounded) supplies:

Special attention is required when using internal or external EMC filters with ungrounded supplies, because in the event of a ground (earth) fault in the motor circuit the drive may not trip and the filter could be over-stressed. In this case, either the filter must not be used (removed) or additional independent motor ground fault protection must be provided, refer to Table 4-3 . For details of ground fault protection contact the supplier of the drive.

A ground fault in the supply has no effect in any case. If the motor must continue to run with a ground fault in its own circuit then an input isolating transformer must be provided and if an EMC filter is required it must be located in the primary circuit.

Unusual hazards can occur on ungrounded supplies with more than one source, for example on ships. Contact the supplier of the drive for more information.

Table 4-3 Behavior of the drive in the event of a ground (earth) fault with an IT supply

Drive size	Internal filter only	External filter (with internal)
(All sizes)	May not trip – precautions required: <ul style="list-style-type: none"> • Remove the EMC filter* • Use ground leakage relay 	May not trip – precautions required: <ul style="list-style-type: none"> • Do not use EMC filter • Use ground leakage relay

* Please note that the internal filter is not removable on size 9E and 10E.

4.2.2 Supplies requiring line reactors

Input line reactors reduce the risk of damage to the drive resulting from poor phase balance or severe disturbances on the supply network.

Where line reactors are to be used, reactance values of approximately 2 % are recommended. Higher values may be used if necessary, but may result in a loss of drive output (reduced torque at high speed) because of the voltage drop.

For all drive ratings, 2 % line reactors permit drives to be used with a supply unbalance of up to 3.5 % negative phase sequence (equivalent to 5 % voltage imbalance between phases).

Severe disturbances may be caused by the following factors, for example:

- Power factor correction equipment connected close to the drive.
- Large DC drives having no or inadequate line reactors connected to the supply.
- Across the line (DOL) started motor(s) connected to the supply such that when any of these motors are started, the voltage dip exceeds 20 %

Such disturbances may cause excessive peak currents to flow in the input power circuit of the drive. This may cause nuisance tripping, or in extreme cases, failure of the drive.

Drives of low power rating may also be susceptible to disturbance when connected to supplies with a high rated capacity.

Frame size 7 has an internal DC reactor and Frame size 8 and 9A have internal AC line reactors so they do not require AC line reactors except for cases of excessive phase unbalance or extreme supply conditions. Drive sizes 9E and 10E do not have internal input line reactors hence an external input line reactor must be used.

When required each drive must have its own reactor(s). Three individual reactors or a single three-phase reactor should be used.

Reactor current ratings

The current rating of the line reactors should be as follows:

Continuous current rating:

Not less than the continuous input current rating of the drive

Repetitive peak current rating:

Not less than twice the continuous input current rating of the drive



CAUTION

A separate line reactor (INLXXX) of at least the value shown in Table 4-4 and Table 4-5 must be used with size 9E and 10E. Failure to provide sufficient reactance could damage or reduce the service life of the drive.

Table 4-4 Size 7 to 10 Model and Line reactor part number

Size	Drive model	Inductor model	Line reactor part number
7	07200610	INL 2009	4401-0227
	07200750	INL 2010	4401-0228
	07200830	INL 2011	4401-0229
	07400660	INL 4014	4401-0237
	07400770	INL 4015	4401-0238
	07401000	INL 4016	4401-0239
	07500440	INL 5006	4401-0223
	07500550	INL 5010	4401-0245
	07600190	INL 6001	4401-0248
	07600240	INL 6002	4401-0249
	07600290	INL 6003	4401-0250
	07600380	INL 6004	4401-0251
	07600440	INL 6005	4401-0252
	07600540	INL 6006	4401-0253
8	08201160	INL 2012	4401-0230
	08201320	INL 2013	4401-0231
	08401340	INL 4017	4401-0240
	08401570	INL 4018	4401-0241
	08500630	INL 5011	4401-0246
	08500860	INL 5012	4401-0247
	08600630	INL 6007	4401-0254
	08600860	INL 6008	4401-0255
9	09201760, 09202190, 09402000, 09402240	INL 401	4401-0181
	09501040, 09501310, 09601040, 09601310	INL 601	4401-0183
10	10202830, 10203000, 10402700, 10403200	INL 402	4401-0182
	10501520, 10501900, 10601500, 10601780	INL 602	4401-0184

Figure 4-4 Input line reactor dimensions

Table 4-5 Input line reactor ratings (2 %)

Part number	Model	Current	Inductance	Overall width (W)	Overall depth (D)	Overall height (H)	Weight	Max ambient temp	Min airflow	Maximum losses	Quantity required
		A	μH	mm	mm	mm	kg	°C	m/s	W	
4401-0223	INL 5006	47	480	255	130	210	12.5	50	0	122	1
4401-0227	INL 2009	67	130	206	130	160	6.9	50	0	90	1
4401-0228	INL 2010	88	100	206	140	160	9	50	0	97	1
4401-0229	INL 2011	105	80	206	140	160	9.5	50	0	90	1
4401-0230	INL 2012	137	62	254	130	195	12.5	50	0	143	1
4401-0231	INL 2013	166	51	254	150	195	14	50	0	137	1
4401-0237	INL 4014	74	200	254	130	195	12	50	0	129	1
4401-0238	INL 4015	88	170	254	150	195	14	50	0	127	1
4401-0239	INL 4016	105	140	254	150	195	14	50	0	139	1
4401-0240	INL 4017	155	95	290	160	205	20	50	0	182	1
4401-0241	INL 4018	177	83	290	170	205	22	50	0	200	1
4401-0245	INL 5010	67	340	290	150	205	18	50	0	139	1
4401-0246	INL 5011	88	250	290	170	205	22	50	0	147	1
4401-0247	INL 5012	105	200	290	180	225	25	50	0	167	1
4401-0248	INL 6001	20	1270	206	95	200	5.8	50	0	71	1
4401-0249	INL 6002	26	980	206	130	200	7.4	50	0	80	1
4401-0250	INL 6003	32	880	206	140	200	10	50	0	84	1
4401-0251	INL 6004	39	650	254	130	210	12	50	0	123	1
4401-0252	INL 6005	45	580	254	130	210	12.5	50	0	124	1
4401-0253	INL 6006	67	410	290	150	205	18	50	0	123	1
4401-0254	INL 6007	88	300	290	170	205	22	50	0	169	1
4401-0255	INL 6008	105	240	290	180	225	25	50	0	204	1
4401-0181	INL 401	245	63	240	190	225	32	50	1	148	1
4401-0182	INL 402	370	44	276	200	225	36	50	1	205	1
4401-0183	INL 601	145	178	240	190	225	33	50	1	88	1
4401-0184	INL 602	202	133	276	200	225	36	50	1	116	1

4.2.3 Input inductor calculation

To calculate the inductance required (at Y %), use the following equation:

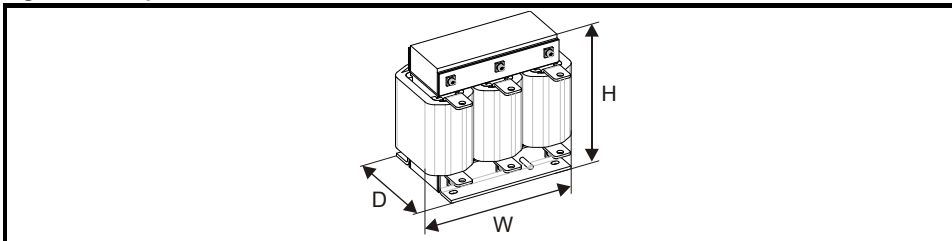
$$L = \frac{Y}{100} \times \frac{V}{\sqrt{3}} \times \frac{1}{2\pi f I}$$

Where:

I = drive rated input current (A)

L = inductance (H)

f = supply frequency (Hz)

V = voltage between lines

4.3 Supplying the *Unidrive M / Unidrive HS* size 7, 8 and 9A drives with DC / DC bus paralleling

The drive may be supplied with DC instead of 3 phase AC.

The connecting of the DC bus between several drives is typically used to:

1. Return energy from a drive which is being overhauled by the load to a second motoring drive.
2. Allow the use of one braking resistor to dissipate regenerative energy from several drives.

There are limitations to the combinations of drives which can be used in this configuration.

For further information, contact the supplier of the drive.

NOTE *Unidrive M/Unidrive HS* size 9E and 10E drives do not have an accessible negative DC terminal. It is recommended that 9D and 10D drives are used as an alternative when this is needed, please refer to the *Modular Installation Guide* for further details.

4.4 24 Vdc supply

The 24 Vdc supply connected to control terminals 1 & 2* provides the following functions:

- It can be used to supplement the drive's own internal 24 V supply when multiple option modules are being used and the current drawn by these module is greater than the drive can supply.
- It can be used as a back-up power supply to keep the control circuits of the drive powered up when the line power supply is removed. This allows any fieldbus modules, application modules, encoders or serial communications to continue to operate.
- It can be used to commission the drive when the line power supply is not available, as the display operates correctly. However, the drive will be in the Under voltage state unless either line power supply or low voltage DC operation is enabled, therefore diagnostics may not be possible. (Power down save parameters are not saved when using the 24 V back-up power supply input).
- If the DC bus voltage is too low to run the main SMPS in the drive, then the 24 V supply can be used to supply all the low voltage power requirements of the drive. *Low Under Voltage Threshold Select* (06.067)** must also be enabled for this to happen.

** Not available on *Unidrive M200 to M400*.

NOTE The power 24 Vdc supply (terminals 51, 52) must be connected to enable the 24 V dc supply to be used as a backup supply, when the line power supply is removed. If the power 24 Vdc supply is not connected none of the above mentioned functions can be used, "Waiting For Power System" will be displayed on the keypad and no drive operations are possible. The location of the power 24 Vdc can be identified from Figure 4-5 and Figure 4-6 *Location of the 24 Vdc power supply connection on size 8 to 10* on page 65.

Table 4-6 24 Vdc Supply connections

Function	Sizes 7-10
Supplement the drive's internal supply	Terminal 1, 2*
Back-up supply for the control circuit	Terminal 1, 2* 51, 52

* Terminal 9 on *Unidrive M702* and *HS72* (24 Vdc control supply on *Unidrive M200 to M400* is supplied via AI-Backup Adaptor)

The working voltage range of the control 24 V power supply is as follows:

1	0V common
2	+24 Vdc *
Nominal operating voltage	24.0 Vdc
Minimum continuous operating voltage	19.2 V
Maximum continuous operating voltage	28.0 V
Minimum start up voltage	21.6 V
Maximum power supply requirement at 24 V	40 W
Recommended fuse	3 A, 50 Vdc

* Terminal 9 on *Unidrive M702* and *HS72*

Minimum and maximum voltage values include ripple and noise. Ripple and noise values must not exceed 5 %.

The working range of the 24 V power supply is as follows:

51	0V common
52	+24 Vdc
Nominal operating voltage	24.0 Vdc
Minimum continuous operating voltage	19.2 Vdc
Maximum continuous operating voltage	30 Vdc (IEC), 26 Vdc (UL)
Minimum startup voltage	21.6 Vdc
Maximum power supply requirement	60 W
Recommended fuse	4 A @ 50 Vdc

Figure 4-5 Location of the 24 Vdc power supply connection on size 7

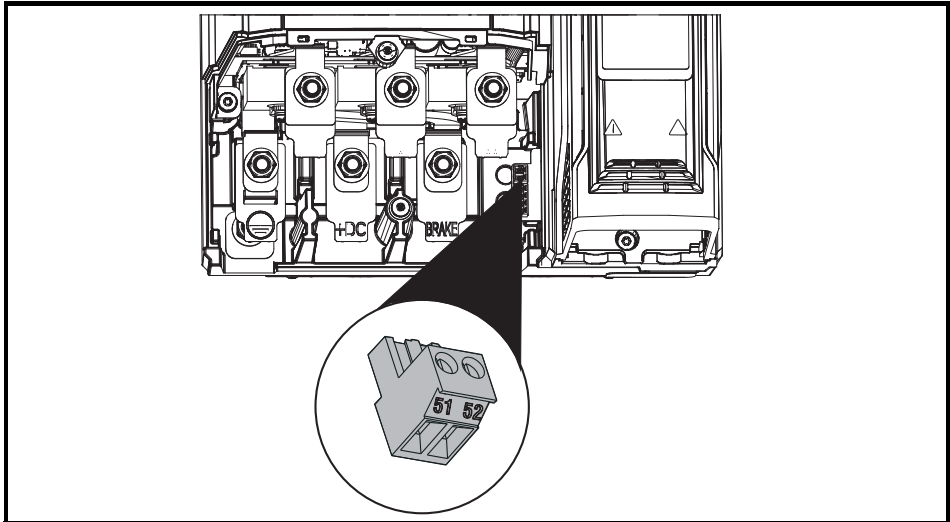
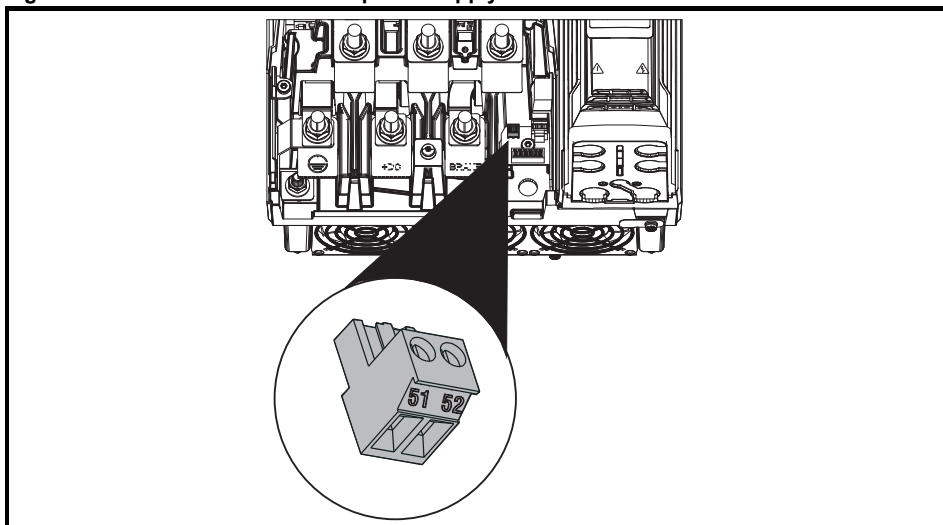

Figure 4-6 Location of the 24 Vdc power supply connection on size 8 to 10



4.5 Low voltage operation

With the addition of a 24 Vdc power supply to supply the control circuits, the drive is able to operate from a low voltage DC supply with a range from 24 Vdc to the maximum DC volts. It is possible for the drive to go from operating on a normal line power supply voltage to operating on a much lower supply voltage without interruption (not available with *Unidrive M200* to *M400*).

Going from low voltage operation to normal mains operation requires the inrush current to be controlled. This may be provided externally. If not, the drive supply can be interrupted to utilise the normal soft starting method in the drive.

To fully exploit the new low voltage mode of operation, the under voltage level is now user programmable. For application data, contact the supplier of the drive.

The working voltage range of the low voltage DC power supply is as follows:

Size 9 to 10

Minimum continuous operating voltage:	26 V
Minimum start up voltage:	32 V
Maximum over voltage trip threshold:	230 V drives: 415 V
	400 V drives: 830 V
	575 V drives: 990 V
	690 V drives: 1190 V

NOTE

Unidrive M/Unidrive HS size 9E and 10E drives do not have an accessible negative DC terminal. It is recommended that 9D and 10D drives are used as an alternative when this is needed, please refer to the *Modular Installation Guide* for further details.

In low voltage mode only, with frame size 9 to 10, a 24 V supply needs to be provided for the heatsink fan. The fan supply should be connected to terminal 61 and 62.

61	0V common
62	+24 Vdc heatsink fan supply
Size 9 to 10	
Nominal operating voltage	24.0 Vdc
Minimum continuous operating voltage	23.5 Vdc
Maximum continuous operating voltage	27 Vdc
Current consumption	Size 9 to 10 (all): 6A
Recommended power supply	24 V, 7 A
Recommended fuse	8A fast blow

Figure 4-7 Location of the heatsink fan supply connector on size 9 to 10

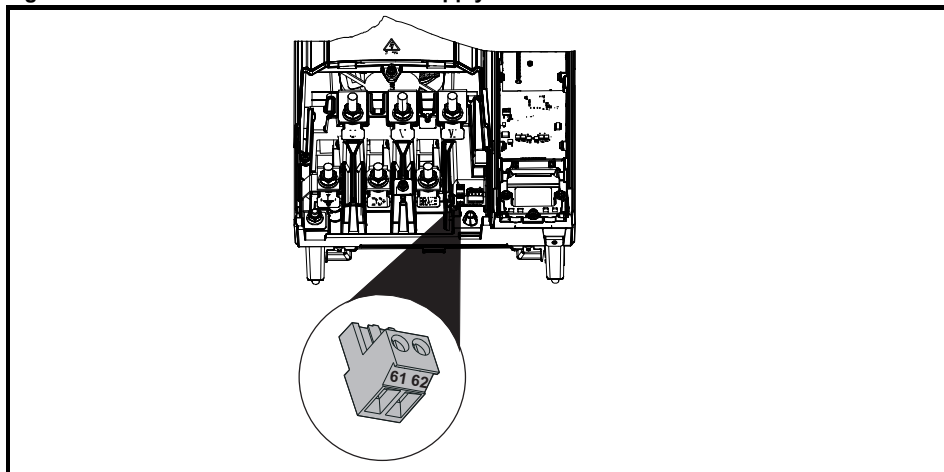

4.6 Heatsink fan supply

When operating on normal mains supply the heatsink fan on all drive sizes is supplied internally by the drive. When operating size 9 and 10 in low voltage mode it is necessary to connect an external 24V supply to terminal 61 and 62 if heatsink fan operation is required. Please see section 4.5 *Low voltage operation* on page 65 for more details.

4.7 Ratings

See section 2.4 *Ratings* on page 17.

Maximum continuous input current

The values of maximum continuous input current are given to aid the selection of cables and fuses. These values are stated for the worst case condition with the unusual combination of stiff supply with high imbalance. The value stated for the maximum continuous input current would only be seen in one of the input phases. The current in the other two phases would be significantly lower.

The values of maximum input current are stated for a supply with a 2% negative phase-sequence imbalance and rated at the maximum supply fault current given in section 2.4 *Ratings* on page 17.

The nominal cable sizes given in section 2.4 *Ratings* on page 17 are only a guide. Refer to local wiring regulations for the correct size of cables. In some cases a larger cable is required to avoid excessive voltage drop.

NOTE

The nominal output cable sizes in section 2.4 *Ratings* on page 17 assume that the motor maximum current matches that of the drive. Where a motor of reduced rating is used the cable rating may be chosen to match that of the motor. To ensure that the motor and cable are protected against over-load, the drive must be programmed with the correct motor rated current.

**Fuses**

The AC supply to the drive must be installed with suitable protection against overload and short-circuits. Nominal fuse ratings are shown in section 2.4 *Ratings* on page 17. Failure to observe this requirement will cause risk of fire.

A fuse or other protection must be included in all live connections to the AC supply.

Fuse types

The fuse voltage rating must be suitable for the drive supply voltage.

4.7.1 Main AC supply contactor

The recommended AC supply contactor type is AC1.

4.8 Output circuit and motor protection

The output circuit has fast-acting electronic short-circuit protection which limits the fault current to typically no more than five times the rated output current, and interrupts the current in approximately 20 μ s. No additional short-circuit protection devices are required.

The drive provides overload protection for the motor and its cable. For this to be effective, Pr **00.046** (Pr **00.006** on *Unidrive M200* to *M400*) *Motor rated current* must be set to suit the motor.



Pr **00.046** (Pr **00.006** on *Unidrive M200* to *M400*) *Motor rated current* must be set correctly to avoid a risk of fire in the event of motor overload.

There is also provision for the use of a motor thermistor to prevent over-heating of the motor, e.g. due to loss of cooling.

4.8.1 Motor cable types

Since capacitance in the motor cable causes loading on the output of the drive, ensure the cable length does not exceed the values given in Table 5-23 *Maximum motor cable lengths* on page 111.

Use 105 °C (221 °F) (UL 60/75 °C temp rise) PVC-insulated cable with copper conductors having a suitable voltage rating, for the following power connections:

- AC supply to external EMC filter (when used)
- AC supply (or external EMC filter) to drive
- Drive to motor
- Drive to braking resistor

4.8.2 High-capacitance / reduced diameter cables

The maximum cable length is reduced from that shown in Table 5-23 *Maximum motor cable lengths* on page 111 if high capacitance or reduced diameter motor cables are used.

Most cables have an insulating jacket between the cores and the armor or shield; these cables have a low capacitance and are recommended. Cables that do not have an insulating jacket tend to have high capacitance; if a cable of this type is used, the maximum cable length is half that quoted in the tables, (Figure 4-8 shows how to identify the two types).

Figure 4-8 Cable construction influencing the capacitance

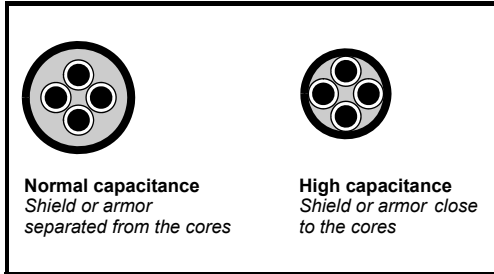

The maximum motor cable lengths specified in section 5.1.21 *Maximum motor cable lengths* on page 111 is shielded and contains four cores. Typical capacitance for this type of cable is 130 pF/m (i.e. from one core to all others and the shield connected together).

4.8.3 Motor winding voltage

The PWM output voltage can adversely affect the inter-turn insulation in the motor. This is because of the high rate of change of voltage, in conjunction with the impedance of the motor cable and the distributed nature of the motor winding.

For normal operation with AC supplies up to 500 Vac and a standard motor with a good quality insulation system, there is no need for any special precautions. In case of doubt the motor supplier should be consulted.

Special precautions are recommended under the following conditions, but only if the motor cable length exceeds 10 m:

- AC supply voltage exceeds 500 V
- DC supply voltage exceeds 670 V i.e. regenerative / AFE supply
- Operation of 400 V drive with continuous or very frequent sustained braking
- Multiple motors connected to a single drive

For multiple motors, the precautions given in *section 4.8.4 Multiple motors* should be followed.

For the other cases listed, it is recommended that an inverter-rated motor be used. This has a reinforced insulation system intended by the manufacturer for repetitive fast-rising pulsed voltage operation.

Users of 575 V NEMA rated motors should note that the specification for inverter-rated motors given in NEMA MG1 section 31 is sufficient for motoring operation but not where the motor spends significant periods braking. In that case an insulation peak voltage rating of 2.2 kV is recommended.

If it is not practical to use an inverter-rated motor, an output choke (inductor) should be used. The recommended type is a simple iron-cored component with a reactance of about 2 %. The exact value is not critical. This operates in conjunction with the capacitance of the motor cable to increase the rise-time of the motor terminal voltage and prevent excessive electrical stress.

4.8.4 Multiple motors

Open-loop only

If the drive is to control more than one motor, one of the fixed V/F modes should be selected (Pr **05.014** = Fixed or Squared). Make the motor connections as shown in Figure 4-9 and Figure 4-10. The maximum motor cable lengths specified in section 5.1.21 *Maximum motor cable lengths* on page 111 apply to the sum of the total cable lengths from the drive to each motor.

It is recommended that each motor is connected through a protection relay since the drive cannot protect each motor individually. For Δ connection, a sinusoidal filter or an output inductor must be connected as shown in Figure 4-10, even when the cable lengths are less than the maximum permissible. For high DC voltages or when supplied by a regen system, a sinusoidal filter is recommended. For details of filter or inductor sizes refer to the supplier of the drive.

Figure 4-9 Preferred chain connection for multiple motors

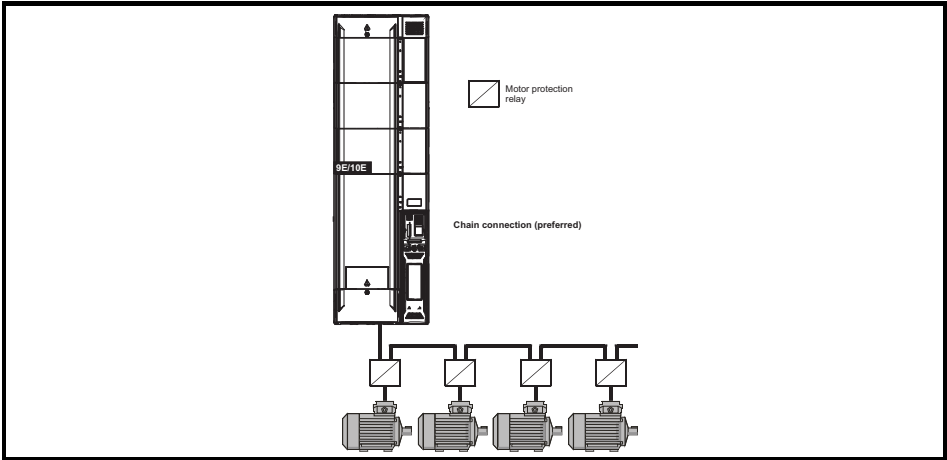
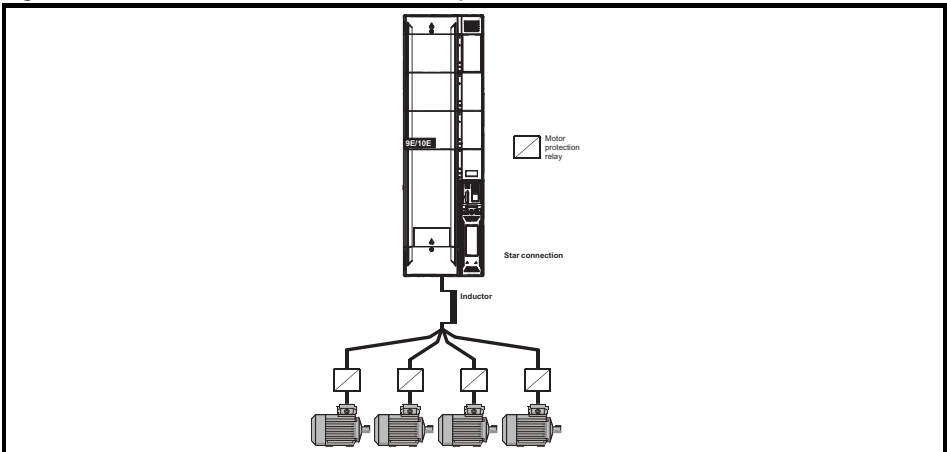

Figure 4-10 Alternative connection for multiple motors



4.8.5 λ / Δ motor operation

The voltage rating for λ and Δ connections of the motor should always be checked before attempting to run the motor.

The default setting of the motor rated voltage parameter is the same as the drive rated voltage, i.e.

400 V drive 400 V rated voltage

230 V drive 230 V rated voltage

A typical 3 phase motor would be connected in λ for 400 V operation or Δ for 230 V operation, however, variations on this are common e.g. λ 690 V Δ 400 V.

Incorrect connection of the windings will cause severe under or over fluxing of the motor, leading to a very poor output torque or motor saturation and overheating respectively.

4.8.6 Output contactor



If the cable between the drive and the motor is to be interrupted by a contactor or circuit breaker, ensure that the drive is disabled before the contactor or circuit breaker is opened or closed. Severe arcing may occur if this circuit is interrupted with the motor running at high current and low speed.

A contactor is sometimes required to be installed between the drive and motor for safety purposes. The recommended motor contactor is the AC3 type.

Switching of an output contactor should only occur when the output of the drive is disabled.

Opening or closing of the contactor with the drive enabled will lead to:

1. OI ac trips (which cannot be reset for 10 seconds)
2. High levels of radio frequency noise emission
3. Increased contactor wear and tear

The Drive Enable terminal when opened provides a Safe Torque Off* function. This can in many cases replace output contactors.

For further information see the *Control User Guide*.

*There is no Safe Torque Off function on the *Unidrive M200/201*

4.9 Braking

Braking occurs when the drive is decelerating the motor, or is preventing the motor from gaining speed due to mechanical influences. During braking, energy is returned to the drive from the motor.

When the motor is being braked by the drive, the maximum regenerated power that the drive can absorb is equal to the power dissipation (losses) of the drive.

When the regenerated power is likely to exceed these losses, the DC bus voltage of the drive increases. Under default conditions, the drive brakes the motor under PI control, which extends the deceleration time as necessary in order to prevent the DC bus voltage from rising above a user defined set-point.

If the drive is expected to rapidly decelerate a load, or to hold back an overhauling load, a braking resistor must be installed.

Table 4-7 shows the default DC voltage level at which the drive turns on the braking transistor. However the braking resistor turn on and the turn off voltages are programmable with *Braking IGBT Lower Threshold* (06.073) and *Braking IGBT Upper Threshold* (06.074).

Table 4-7 Braking transistor turn on voltage

Drive voltage rating	DC bus voltage level
200 V	390 V
400 V	780 V
575 V	930 V
690 V	1120 V

NOTE When a braking resistor is used, Pr **00.015** (Pr **00.028** on *Unidrive M200 to M400*) should be set to FAST ramp mode.

4.9.1 External braking resistor



Overload protection

When an external braking resistor is used, it is essential that an overload protection device is incorporated in the braking resistor circuit; this is described in *Figure 4-11 on page 73*.

When a braking resistor is to be mounted outside the enclosure, ensure that it is mounted in a ventilated metal housing that will perform the following functions:

- Prevent inadvertent contact with the resistor
- Allow adequate ventilation for the resistor

When compliance with EMC emission standards is required, external connection requires the cable to be armored or shielded, since it is not fully contained in a metal enclosure. See section 4.11.6 *Compliance with generic emission standards* on page 85 for further details.

Internal connection does not require the cable to be armored or shielded.

Table 4-8 Minimum resistance values and peak power rating for the braking resistor at 40 °C (104 °F)

Model	Minimum resistance*	Instantaneous power rating	Continuous power rating
	Ω	kW	kW
200 V			
07200610	4.5	37.6	15
07200750	4.5	37.6	18.5
07200830	4.5	37.6	22
08201160	2.3	73.5	30
08201320	2.3	73.5	37
09201760 (9A)	2	84.5	45
09202190 (9A)	2	84.5	45
09201760 (9E)	1.4	120.8	45
09202190 (9E)	1.4	120.8	55
10202830	1.7	99.5	75
10203000	1.7	99.5	90
400 V			
07400660	7.5	90.2	30
07400770	7.5	90.2	37
07401000	7.5	90.2	45
08401340	6.3	107.4	55
08401570	6.3	107.4	75
09402000 (9A)	3.6	187.8	90
09402240 (9A)	3.6	187.8	110

Model	Minimum resistance*	Instantaneous power rating	Continuous power rating
	Ω	kW	kW
09402000 (9E)	2.6	260	90
09402240 (9E)	2.6	260	110
10402700	3.1	218.1	132
10403200	3.1	218.1	160
575 V			
07500440	11	87.4	30
07500550	11	87.4	37
08500630	5.5	174.8	45
08500860	5.5	174.8	55
09501040 (9A)	5.1	188.5	75
09501310 (9A)	5.1	188.5	90
09501040 (9E)	3.3	291.3	75
09501310 (9E)	3.3	291.3	90
10501520	3.3	291.3	110
10501900	3.3	291.3	132
690 V			
07600190	13	107.3	15
07600240	13	107.3	18.5
07600290	13	107.3	22
07600380	13	107.3	30
07600440	13	107.3	37
07600540	13	107.3	45
08600630	5.5	253.5	55
08600860	5.5	253.5	75
09601040 (9A)	6.5	214.5	90
09601310 (9A)	6.5	214.5	110
09601040 (9E)	4.2	331.9	90
09601310 (9E)	4.2	331.9	110
10601500	4.2	331.9	132
10601780	3.8	366.8	160

*Resistor tolerance: $\pm 10\%$.

The minimum resistance specified are for stand-alone drive systems only. If the drive is to be used as part of a common DC bus system different values may be required. Contact the supplier of the drive for more information.

For high-inertia loads or under continuous braking, the continuous power dissipated in the braking resistor may be as high as the power rating of the drive. The total energy dissipated in the braking resistor is dependent on the amount of energy to be extracted from the load.

The instantaneous power rating refers to the short-term maximum power dissipated during the on intervals of the pulse width modulated braking control cycle. The braking resistor must be able to withstand this dissipation for short intervals (milliseconds). Higher resistance values require proportionately lower instantaneous power ratings.

In most applications, braking occurs only occasionally. This allows the continuous power rating of the braking resistor to be much lower than the power rating of the drive. It is therefore essential that the instantaneous power rating and energy rating of the braking resistor are sufficient for the most extreme braking duty that is likely to be encountered.

Optimization of the braking resistor requires careful consideration of the braking duty.

Select a value of resistance for the braking resistor that is not less than the specified minimum

resistance. Larger resistance values may give a cost saving, as well as a safety benefit in the event of a fault in the braking system. Braking capability will then be reduced, which could cause the drive to trip during braking if the value chosen is too large.

Thermal protection circuit for the braking resistor

The thermal protection circuit must disconnect the AC supply from the drive if the resistor becomes overloaded due to a fault. Figure 4-11 shows a typical circuit arrangement.

Figure 4-11 Typical protection circuit for a braking resistor

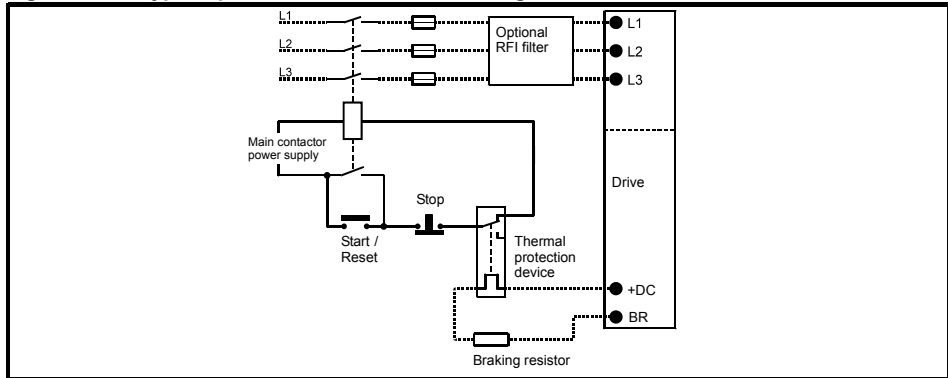

See Figure 4-1 on page 55, Figure 4-2 on page 56 and Figure 4-3 on page 57 for the location of the +DC and braking resistor connections.

4.9.2 Braking resistor software overload protection

The drive software contains an overload protection function for a braking resistor. In order to enable and set-up this function, it is necessary to enter three values into the drive:

- *Braking Resistor Rated Power* (10.030)
- *Braking Resistor Thermal Time Constant* (10.031)
- *Braking Resistor Resistance* (10.061)

This data should be obtained from the manufacturer of the braking resistors. The braking resistor thermal time constant can be calculated from resistor data sheet values using the following equation:

$$\text{Pr 10.031} = \frac{\text{Resistor pulse power rating} \times \text{Braking time}}{\text{Resistor continuous power rating}}$$

Pr 10.039 gives an indication of braking resistor temperature based on a simple thermal model. Zero indicates the resistor is close to ambient and 100 % is the maximum temperature the resistor can withstand. A 'Brake Resistor' alarm is given if this parameter is above 75 % and the braking IGBT is active. A Brake R Too Hot trip will occur if Pr 10.039 reaches 100 %, when Pr 10.037 is set to 0 (default value) or 1.

If Pr 10.037 is equal to 2 or 3, a Brake R Too Hot trip will not occur when Pr 10.039 reaches 100 %, but instead the braking IGBT will be disabled until Pr 10.039 falls below 95 %. This option is intended for applications with parallel connected DC buses where there are several braking resistors, each of which cannot withstand full DC bus voltage continuously. With this type of application it is unlikely the braking energy will be shared equally between the resistors because of voltage measurement tolerances within the individual drives. Therefore with Pr 10.037 set to 2 or 3, then as soon as a resistor has reached its maximum temperature the drive will disable the braking IGBT, and another resistor on another drive will take up the braking energy. Once Pr 10.039 has fallen below 95 % the drive will allow the braking IGBT to operate again.

See the *Parameter Reference Guide* for more information on Pr 10.030, Pr 10.031, Pr 10.037 and Pr 10.039.

This software overload protection should be used in addition to an external overload protection device.

4.10 Ground leakage

The ground leakage current depends upon whether the internal EMC filter is installed. The drive is supplied with the filter installed.

With internal filter installed:

- 56 mA AC at 400 V 50 Hz (proportional to supply voltage and frequency)
- 18 μ A DC with a 600 V DC bus (33 M Ω)

With internal filter removed*:

<1mA

Note that in both cases there is an internal voltage surge protection device connected to ground. Under normal circumstances this carries negligible current.

*Please note that the internal filter is not removable on size 9E and 10E.



When the internal filter is installed the leakage current is high. In this case a permanent fixed ground connection must be provided, or other suitable measures taken to prevent a safety hazard occurring if the connection is lost.

4.10.1 Use of residual current device (RCD)

There are three common types of ELCB / RCD:

1. AC - detects AC fault currents
2. A - detects AC and pulsating DC fault currents (provided the DC current reaches zero at least once every half cycle)
3. B - detects AC, pulsating DC and smooth DC fault currents
 - Type AC should never be used with drives.
 - Type A can only be used with single phase drives
 - Type B must be used with three phase drives



Only type B ELCB / RCD are suitable for use with 3 phase inverter drives.

If an external EMC filter is used with an ELCB / RCD, a delay of at least 50 ms should be incorporated to ensure spurious trips are not seen. The leakage current is likely to exceed the trip level if all of the phases are not energized simultaneously.

4.11 EMC (Electromagnetic compatibility)

The requirements for EMC are divided into three levels in the following three sections:

- section 4.11.4, General requirements for EMC this is for all applications, to ensure reliable operation of the drive and minimise the risk of disturbing nearby equipment. The immunity standards specified in section 5.1.24 *Electromagnetic compatibility (EMC)* on page 114 will be met, but no specific emission standards are applied.
- section 4.11.5, Requirements for meeting the EMC standard for power drive systems, IEC 61800-3 (EN 61800-3:2004+A1:2012).
- section 4.11.6, Requirements for meeting the generic emission standards for the industrial environment, IEC 61000-6-4, EN 61000-6-4:2007+A1:2011.

The recommendations of section 4.11.4 will usually be sufficient to avoid causing disturbance to adjacent equipment of industrial quality. If particularly sensitive equipment is to be used nearby, or in a non-industrial environment, then the recommendations of section 4.11.5 or section 4.11.6 should be followed to give reduced radio-frequency emission.

In order to ensure the installation meets the various emission standards described in:

- The EMC data sheet available from the supplier of the drive
- The Declaration of Conformity at the front of this manual
- Chapter 5 *Technical data* on page 92

The correct external EMC filter must be used and all of the guidelines in section 4.11.4 *General requirements for EMC* on page 80 and section 4.11.6 *Compliance with generic emission standards* on page 85 must be followed.



WARNING

High ground leakage current

When an EMC filter is used, a permanent fixed ground connection must be provided which does not pass through a connector or flexible power cord. This includes the internal EMC filter.

Table 4-9 EMC filter cross reference

Model	CT part number
200 V	
07200610 to 07200830	4200-1132
08201160 to 08201320	4200-1972
09201760 to 09202190 (9A)	4200-3021
09201760 to 09202190 (9E)	4200-4460
10202830 to 10203000	4200-4460
400 V	
07400660 to 07401000	4200-1132
08401340 to 08401570	4200-1972
09402000 to 09402240 (9A)	4200-3021
09402000 to 09402240 (9E)	4200-4460
10402700 to 10403200	4200-4460
575 V	
07500440 to 07500550	4200-0672
08500630 to 08500860	4200-1662
09501040 to 09501310 (9A)	4200-1660
09501040 to 09501310 (9E)	4200-2210
10501520 to 10501900	4200-2210
690 V	
07600190 to 07600540	4200-0672
08600630 to 08600860	4200-1662
09601040 to 09601310 (9A)	4200-1660
09601040 to 09601310 (9E)	4200-2210
10601500 to 10601780	4200-2210



High ground leakage current

When an EMC filter is used, a permanent fixed ground connection must be provided which does not pass through a connector or flexible power cord. This includes the internal EMC filter.

NOTE

The installer of the drive is responsible for ensuring compliance with the EMC regulations that apply where the drive is to be used.

4.11.1 Grounding hardware

The drive is supplied with a grounding bracket to facilitate EMC compliance. They provide a convenient method for direct grounding of cable shields without the use of "pig-tails". Cable shields can be bared and clamped to the grounding bracket using metal clips or clamps¹ (not supplied) or cable ties. Note that the shield must in all cases be continued through the clamp to the intended terminal on the drive, in accordance with the connection details for the specific signal.

¹ A suitable clamp is the Phoenix DIN rail mounted SK14 cable clamp (for cables with a maximum outer diameter of 14 mm).

- See Figure 4-12 for details on installing the grounding bracket.

Figure 4-12 Installation of control grounding bracket (all sizes -Unidrive M700 size 3 shown)

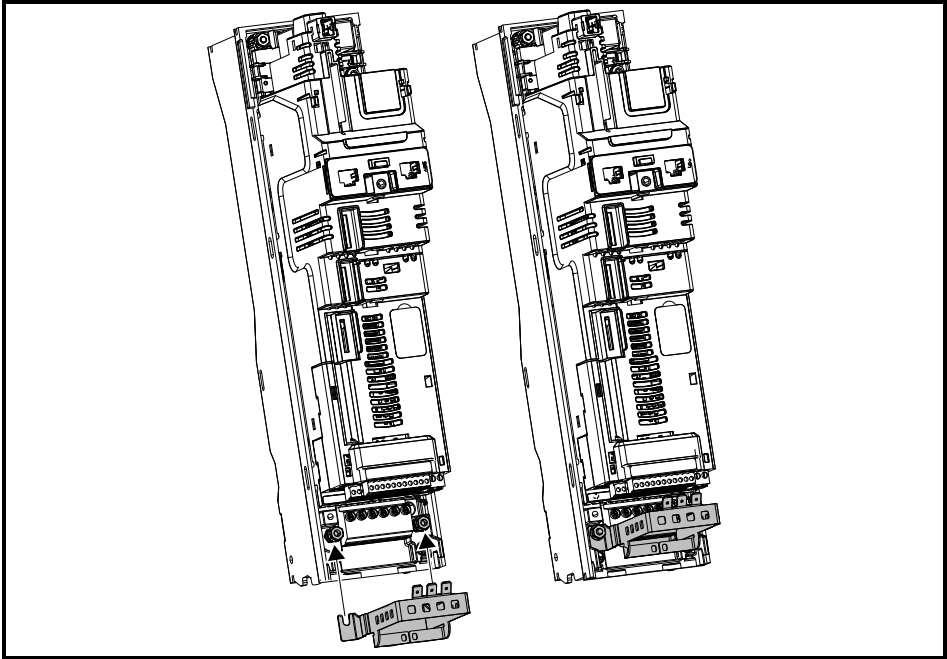

Loosen the ground connection nuts and slide the grounding bracket in the direction shown. Once in place, the ground connection nuts should be tightened with a maximum torque of 2 N m (1.47 lb ft).

A faston tab is located on the grounding bracket for the purpose of connecting the drive 0V to ground should the user require to do so.

4.11.2 Internal EMC filter

It is recommended that the internal EMC filter be kept in place unless there is a specific reason for removing it.



When the drive is used with ungrounded (IT) supplies the internal EMC filter must be removed unless additional motor ground fault protection is installed.

For instructions on removal, refer to Figure . Please note that the internal filter is not removable on size 9E and 10E. For details of ground fault protection contact the supplier of the drive.

If the drive is part of a regen system or it is connected to an IT supply then the internal EMC filter must be removed.

The internal EMC filter reduces radio-frequency emission into the line power supply. Where the motor cable is short, it permits the requirements of EN 61800-3:2004 to be met for the second environment - see section 4.11.5 and section 5.1.24. For longer motor cables the filter continues to provide a useful reduction in emission level, and when used with any length of shielded motor cable up to the limit for the drive, it is unlikely that nearby industrial equipment will be disturbed. It is recommended that the filter be used in all applications unless the instructions given above require it to be removed or the ground leakage current of the drive is unacceptable.



The supply must be disconnected before removing the internal EMC filter.

Figure 4-13 Removal of the size 7, 8 and 9A internal EMC filter and line to ground varistors (size 7 shown)

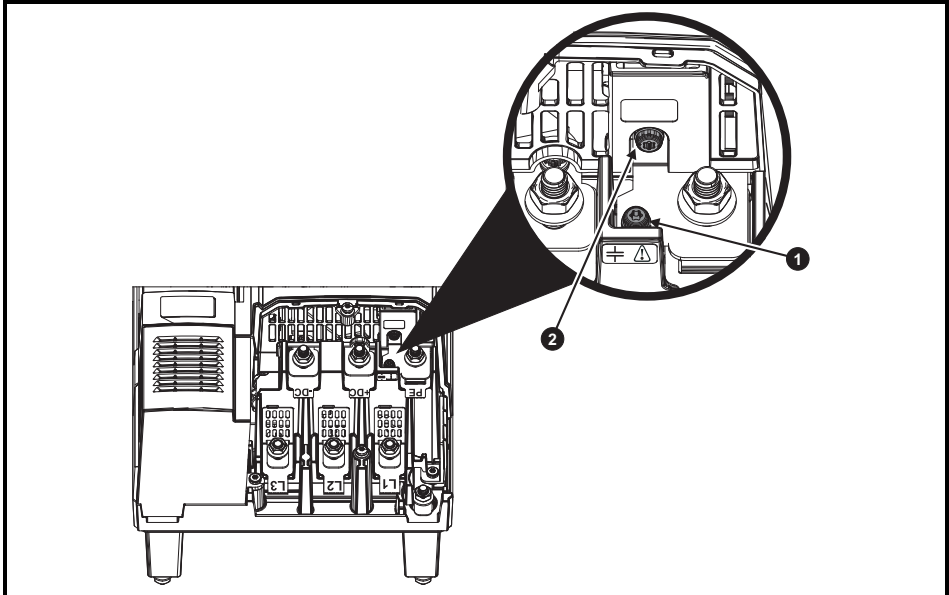

To electrically disconnect the Internal EMC filter, remove the screw as highlighted above (1).

To electrically disconnect the line to ground varistors, remove the screw as highlighted above (2).

NOTE

The Internal EMC filter on size 9E and 10E cannot be removed.

4.11.3 Line to ground varistors



The line to ground varistors should only be removed in special circumstances such as ungrounded supplies with more than one source, for example on ships. Where the line to ground varistors are removed, ensure that line to ground transients are limited to values of category II. This is to ensure that line to ground transients do not exceed 4 kV as the drive insulation system from power to ground is designed to category II. Contact the supplier of the drive for more information.

Figure 4-14 Removal of size 9E and 10E line to ground varistors

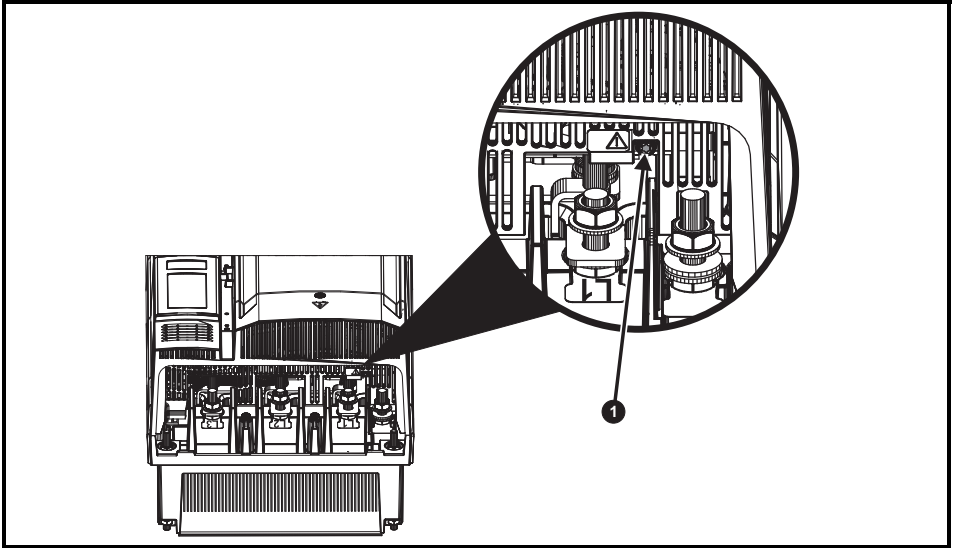

To electrically disconnect the line to ground varistors, remove the screw as highlighted above (1).

4.11.4 General requirements for EMC

Ground (earth) connections

The grounding arrangements should be in accordance with Figure 4-15, which shows a single drive on a back-plate with or without an additional enclosure.

Figure 4-15 shows how to manage EMC when using an unshielded motor cable. However a shielded cable is preferable, in which case it should be installed as shown in section 4.11.6 *Compliance with generic emission standards* on page 85.

Figure 4-15 General EMC enclosure layout showing ground connections

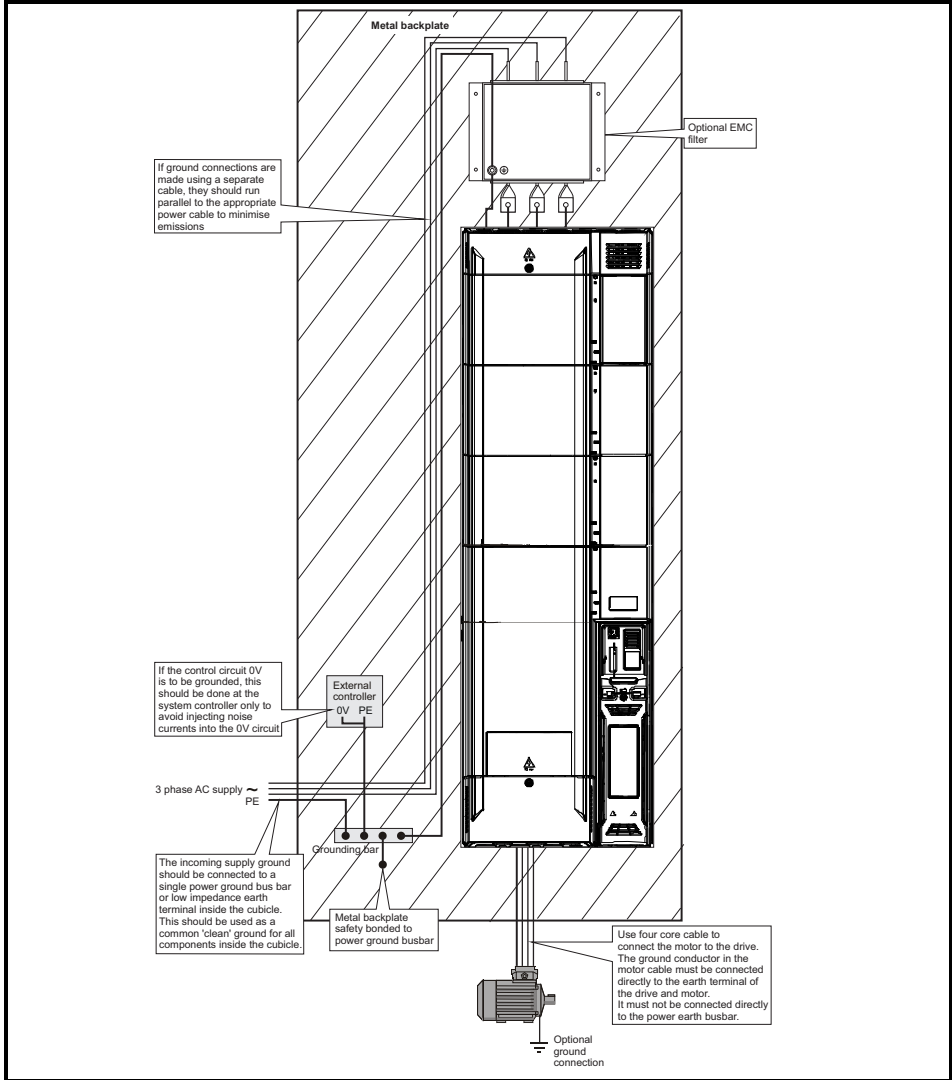

Cable layout

Figure 4-16 indicates the clearances which should be observed around the drive and related 'noisy' power cables by all sensitive control signals / equipment.

Figure 4-16 Drive cable clearances

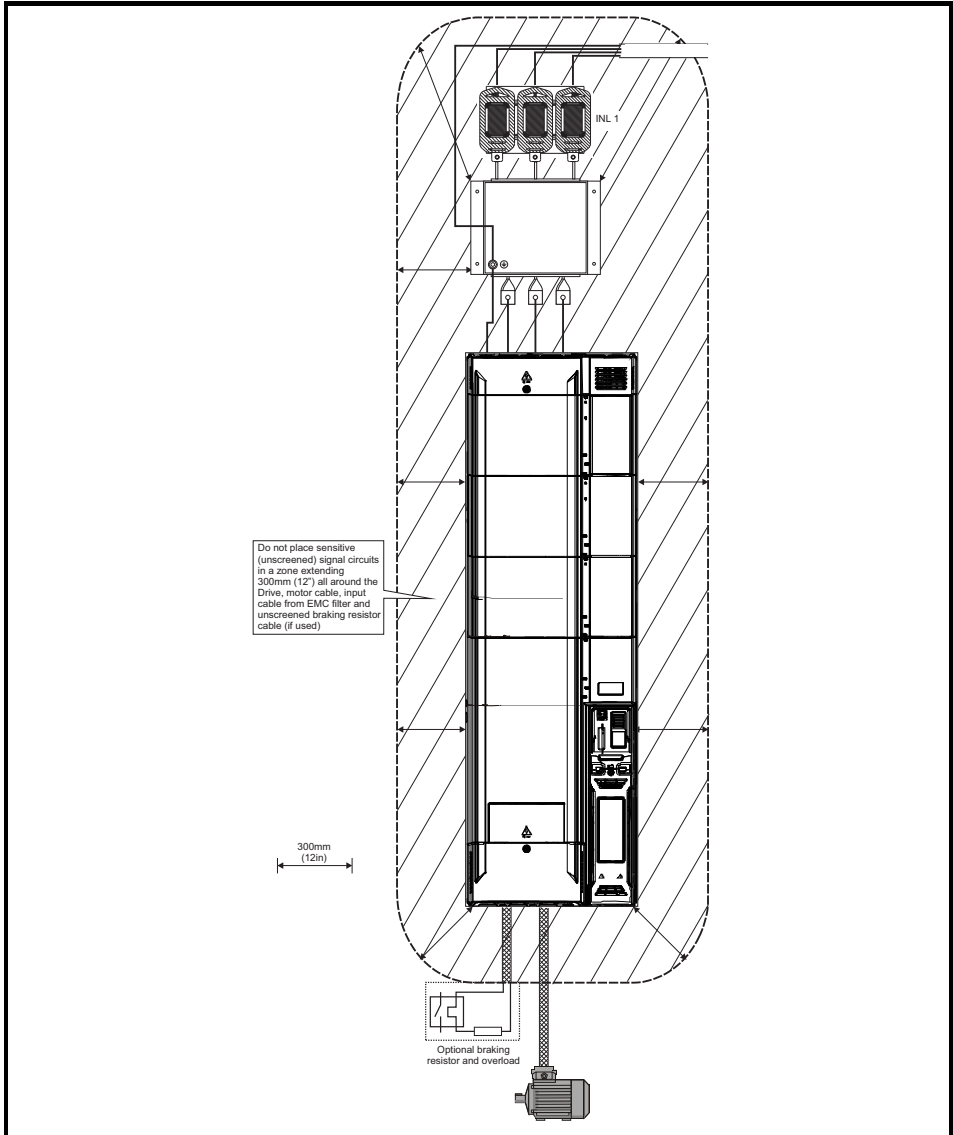

NOTE

Any signal cables which are carried inside the motor cable (i.e. motor thermistor, motor brake) will pick up large pulse currents via the cable capacitance. The shield of these signal cables must be connected to ground close to the motor cable, to avoid this noise current spreading through the control system.

Feedback device cable shielding

Shielding considerations are important for PWM drive installations due to the high voltages and currents present in the output (motor) circuit with a very wide frequency spectrum, typically from 0 to 20 MHz.

The following guidance is divided into two parts:

1. Ensuring correct transfer of data without disturbance from electrical noise originating either within the drive or from outside.
2. Additional measures to prevent unwanted emission of radio frequency noise. These are optional and only required where the installation is subject to specific requirements for radio frequency emission control.

To ensure correct transfer of data, observe the following:

Resolver connections:

- Use a cable with an overall shield and twisted pairs for the resolver signals
- Connect the cable shield to the drive 0V connection by the shortest possible link ("pigtail")
- It is generally preferable not to connect the cable shield to the resolver. However in cases where there is an exceptional level of common-mode noise voltage present on the resolver body, it may be helpful to connect the shield there. If this is done then it becomes essential to ensure the absolute minimum length of "pigtailed" at both shield connections, and possibly to clamp the cable shield directly to the resolver body and to the drive grounding bracket.
- The cable should preferably not be interrupted. If interruptions are unavoidable, ensure the absolute minimum length of "pigtail" in the shield connections at each interruption.

Encoder connections:

- Use a cable with the correct impedance
- Use a cable with individually shielded twisted pairs
- Connect the cable shields to 0V at both the drive and the encoder, using the shortest possible links ("pigtailed")
- The cable should preferably not be interrupted. If interruptions are unavoidable, ensure the absolute minimum length of "pigtail" in the shield connections at each interruption. Preferably, use a connection method which provides substantial metallic clamps for the cable shield terminations.

The above applies where the encoder body is isolated from the motor and where the encoder circuit is isolated from the encoder body. Where there is no isolation between the encoder circuits and the motor body, and in case of doubt, the following additional requirement must be observed. This gives the best possible noise immunity.

- The shields must be directly clamped to the encoder body (no pigtail) and to the drive grounding bracket. This may be achieved by clamping of the individual shields or by providing an additional overall shield which is clamped.

NOTE The recommendations of the encoder manufacturer must also be adhered to for the encoder connections.

NOTE In order to guarantee maximum noise immunity for any application double shielded cable as shown should be used.

In some cases single shielding of each pair of differential signals cables, or a single overall shield with individual shield on the thermistor connections is sufficient. In these cases all the shields should be connected to ground and 0V at both ends.

If the 0V is required to be left floating a cable with individual shields and an overall shield must be used.

Figure 4-17 and Figure 4-18 illustrate the preferred construction of cable and the method of clamping. The outer sheath of the cable should be stripped back enough to allow the clamp to be installed. The shield must not be broken or opened at this point. The clamps should be installed close to the drive or feedback device, with the ground connections made to a ground plate or similar metallic ground surface.

Figure 4-17 Feedback cable, twisted pair

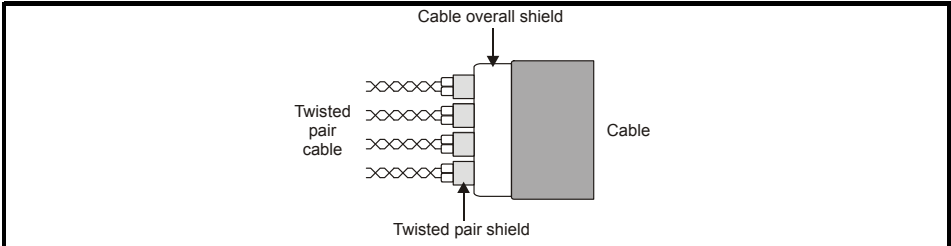
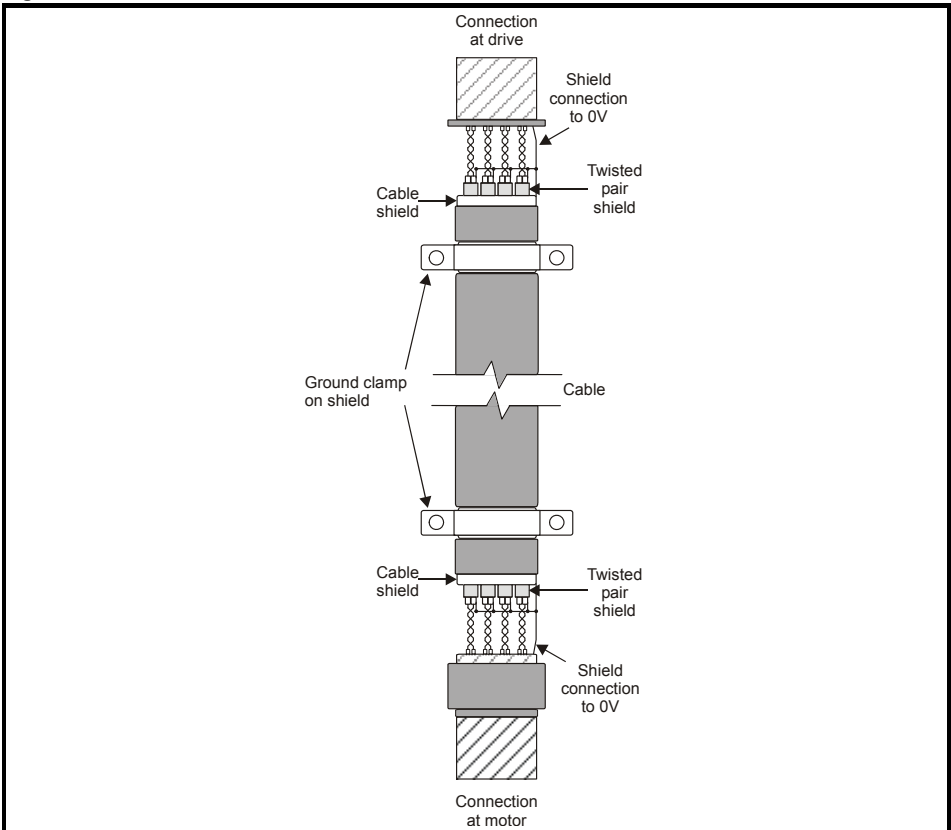

Figure 4-18 Feedback cable connections



To ensure suppression of radio frequency emission, observe the following:

- Use a cable with an overall shield
- Clamp the overall shield to grounded metallic surfaces at both the encoder and the drive, as illustrated in section 4-18

4.11.5 Compliance with EN 61800-3:2004+A1:2012 (standard for Power Drive Systems)

Meeting the requirements of this standard depends on the environment that the drive is intended to operate in, as follows:

Operation in the first environment

Observe the guidelines given in section 4.11.6 *Compliance with generic emission standards* on page 85. An external EMC filter will always be required.



This is a product of the restricted distribution class according to EN 61800-3:2004+A1:2012

In a residential environment this product may cause radio interference in which case the user may be required to take adequate measures.

Operation in the second environment

In all cases a shielded motor cable must be used, and an EMC filter is required for all *Unidrive M / Unidrive HS* drives with a rated input current of less than 100 A.

The drive contains an internal filter for basic emission control. In some cases feeding the motor cables (U, V and W) once through a ferrite ring can maintain compliance for longer cable lengths. The requirements of operating in the second environment are met, depending on the motor cable length for 3 kHz switching frequency as stated in Table 4-10.

Table 4-10 summarizes the performance of the internal filter when used with *Unidrive M / Unidrive HS* size 7 to 10 drives, assembled in the standard recommended configuration.

Table 4-10 Second environment emission compliance, internal filter

Drive size	Voltage	Motor Cable Length (m)	Restriction
7	Any	0 - 100	Restricted
8	200 & 400	0 - 10	Unrestricted
8	200 & 400	10 - 100	Restricted
8	575 & 690	0 - 100	Restricted
9 and 10	200 & 400	0 - 100	Unrestricted
9 and 10	575 & 690	0 - 50	Unrestricted

Key:

Unrestricted: EN 61800-3:2004+A1:2012 second environment, unrestricted distribution.

For longer motor cables, an external filter is required. Where a filter is required, follow the guidelines in *section 4.11.6 Compliance with generic emission standards* .

Where a filter is not required, follow the guidelines given in section 4.11.4 *General requirements for EMC* on page 80.



The second environment typically includes an industrial low-voltage power supply network which does not supply buildings used for residential purposes. Operating the drive in this environment without an external EMC filter may cause interference to nearby electronic equipment whose sensitivity has not been appreciated. The user must take remedial measures if this situation arises. If the consequences of unexpected disturbances are severe, it is recommended that the guidelines in *section 4.11.6 Compliance with generic emission standards* be adhered to.

Refer to section 5.1.24 *Electromagnetic compatibility (EMC)* on page 114 for further information on compliance with EMC standards and definitions of environments.

Detailed instructions and EMC information are given in the *Unidrive M / Unidrive HS EMC Data Sheet* which is available from the supplier of the drive.

4.11.6 Compliance with generic emission standards

Use the recommended filter and shielded motor cable. Observe the layout rules given in Figure 4-19. Ensure the AC supply and ground cables are at least 100 mm from the power module and motor cable.

Figure 4-19 Supply and ground cable clearance

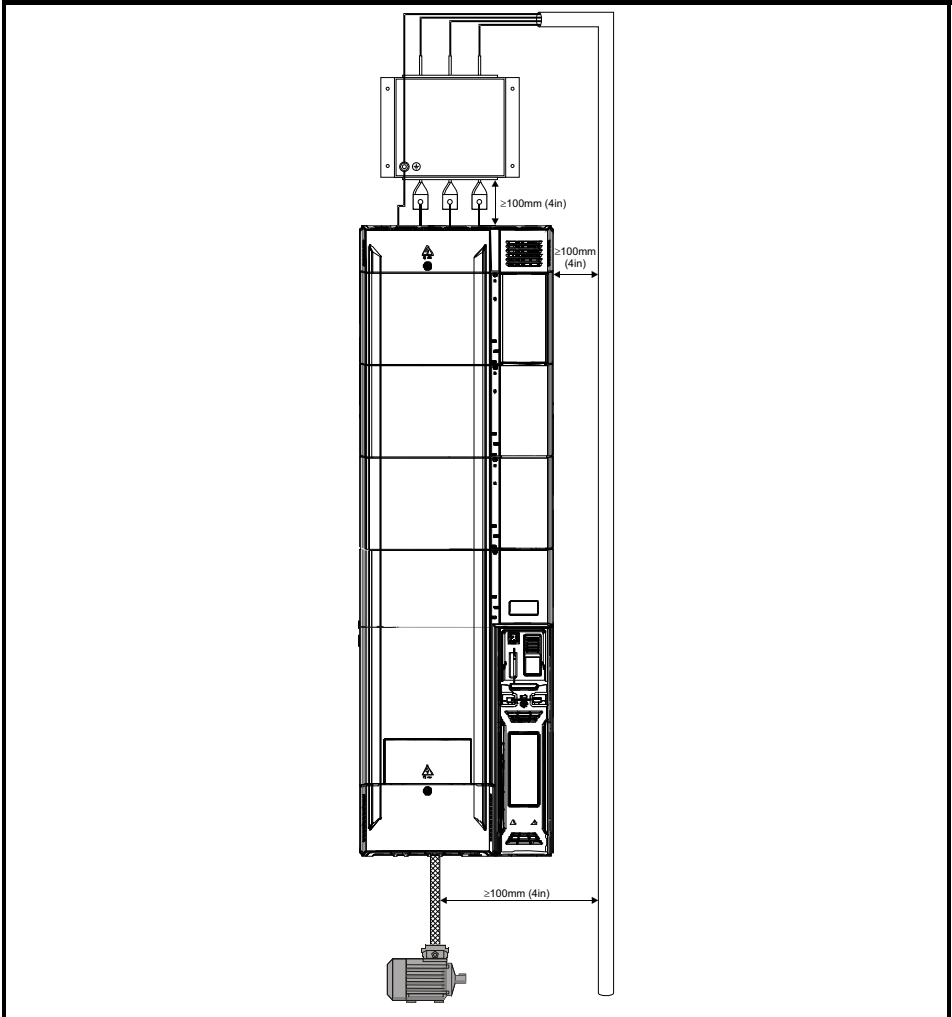

Avoid placing sensitive signal circuits in a zone 300 mm (12 in) all around the power module.

Figure 4-20 Sensitive signal circuit clearance

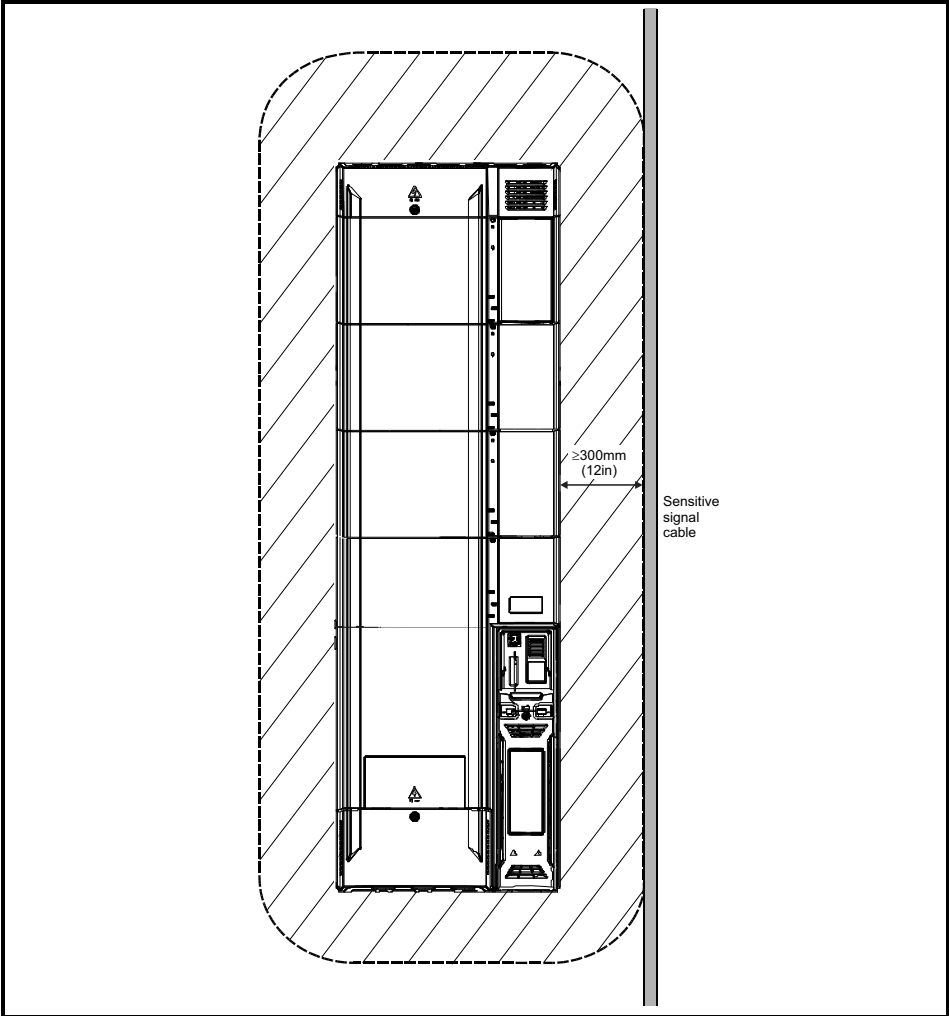

4.11.7 Ensure good EMC grounding.

Figure 4-21 Grounding the drive, motor cable shield and filter

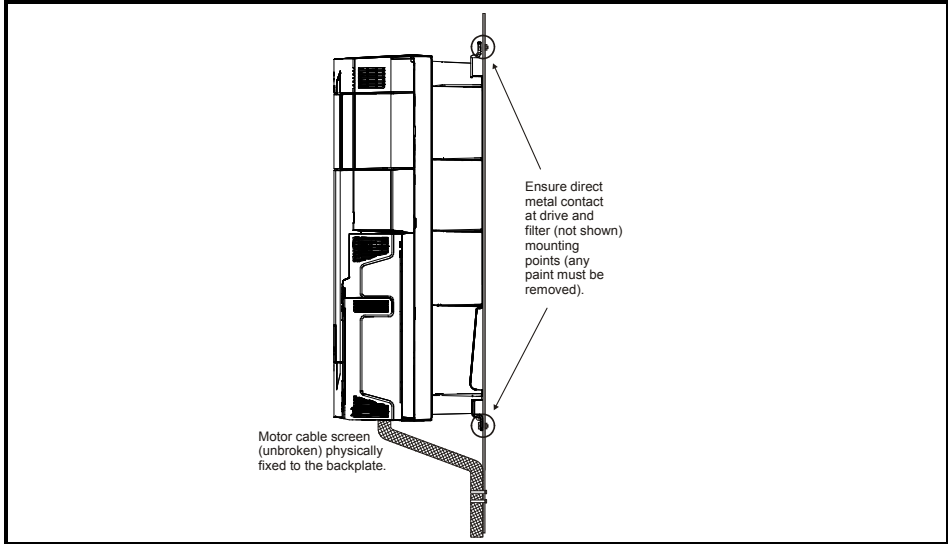

Connect the shield of the motor cable to the ground terminal of the motor frame using a link that is as short as possible and not exceeding 50 mm (2 in) long. A full 360° termination of the shield to the terminal housing of the motor is beneficial.

It is unimportant for EMC purposes whether the motor cable contains an internal (safety) ground core, or there is a separate external ground conductor, or grounding is through the shield alone. An internal ground core will carry a high noise current and therefore it must be terminated as close as possible to the shield termination.

Figure 4-22 Grounding the motor cable shield

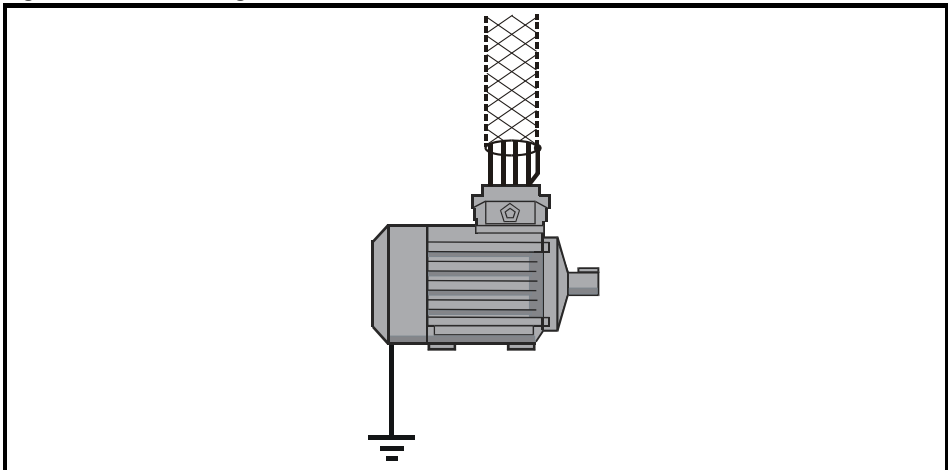

Unshielded wiring to the optional braking resistor(s) may be used, provided the wiring does not run external to the enclosure. Ensure a minimum spacing of 300 mm (12 in) from signal wiring and the AC supply wiring to the external EMC filter. Otherwise this wiring must be shielded.

Figure 4-23 Shielding requirements of optional external braking resistor

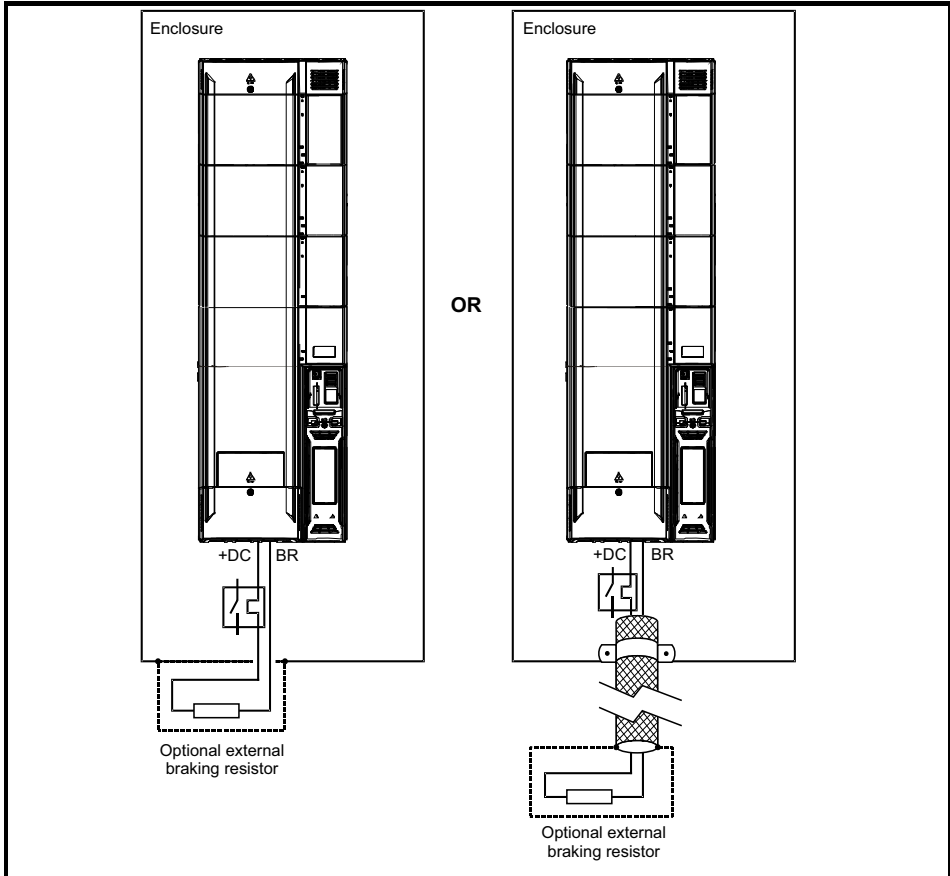

If the control wiring is to leave the enclosure, it must be shielded and the shield(s) clamped to the drive using the grounding bracket as shown in Figure 4-24. Remove the outer insulating cover of the cable to ensure the shield(s) make contact with the bracket, but keep the shield(s) intact until as close as possible to the terminals

Alternatively, wiring may be passed through a ferrite ring, part no. 3225-1004.

Figure 4-24 Grounding of signal cable shields using the grounding bracket

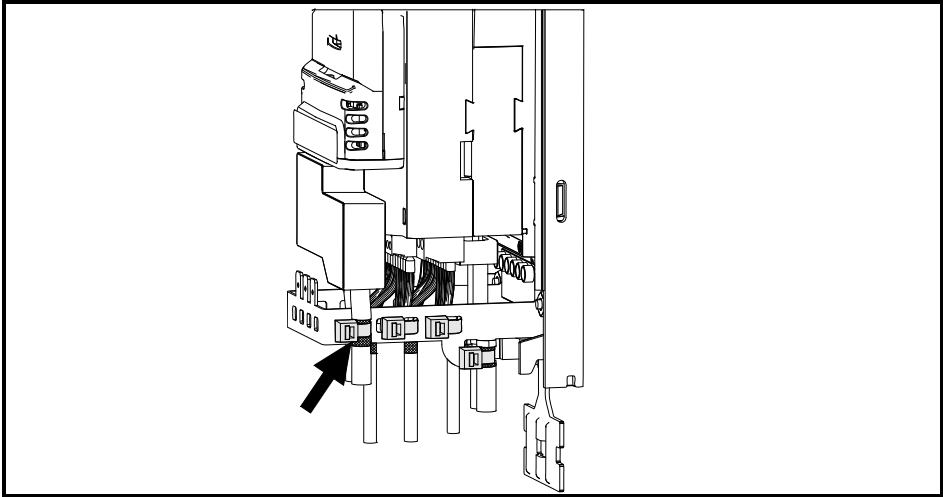

4.11.8 Variations in the EMC wiring

Interruptions to the motor cable

The motor cable should ideally be a single length of shielded or armored cable having no interruptions. In some situations it may be necessary to interrupt the cable, as in the following examples:

- Connecting the motor cable to a terminal block in the drive enclosure
- Installing a motor isolator/disconnect switch for safety when work is done on the motor

In these cases the following guidelines should be followed.

Terminal block in the enclosure

The motor cable shields should be bonded to the back-plate using uninsulated metal cable-clamps which should be positioned as close as possible to the terminal block. Keep the length of power conductors to a minimum and ensure that all sensitive equipment and circuits are at least 0.3m (12 in) away from the terminal block.

Figure 4-25 Connecting the motor cable to a terminal block in the enclosure

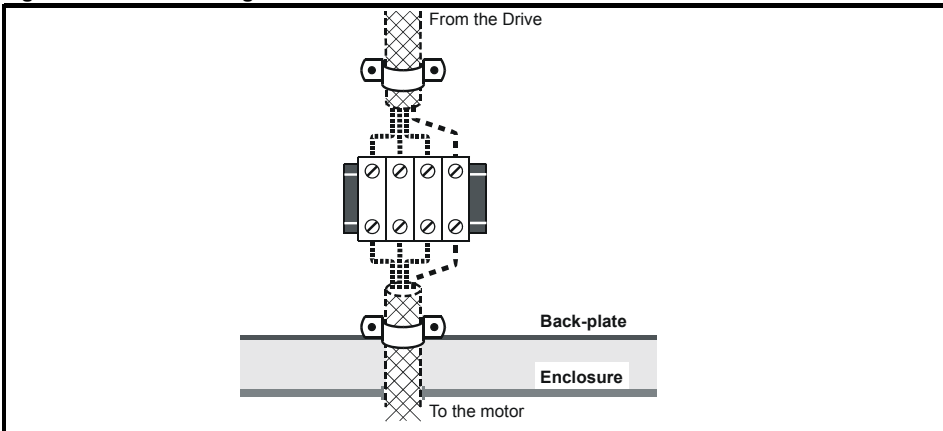

Using a motor isolator/disconnect-switch

The motor cable shields should be connected by a very short conductor having a low inductance. The use of a flat metal coupling-bar is recommended; conventional wire is not suitable.

The shields should be bonded directly to the coupling-bar using uninsulated metal cable-clamps. Keep the length of the exposed power conductors to a minimum and ensure that all sensitive equipment and circuits are at least 0.3 m (12 in) away.

The coupling-bar may be grounded to a known low-impedance ground nearby, for example a large metallic structure which is connected closely to the drive ground.

Figure 4-26 Connecting the motor cable to an isolator/disconnect switch

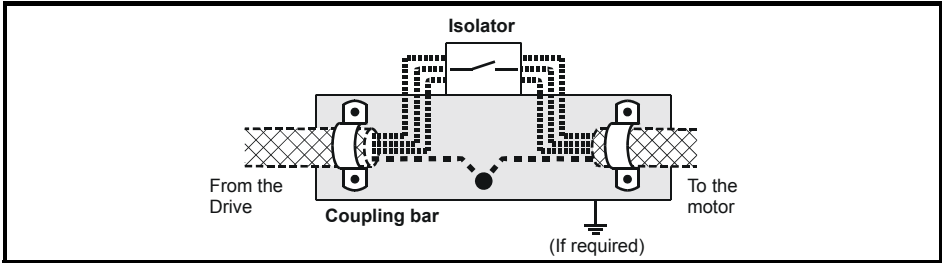

Surge immunity of control circuits - long cables and connections outside a building

The input/output ports for the control circuits are designed for general use within machines and small systems without any special precautions.

These circuits meet the requirements of EN 61000-6-2:2005 (1 kV surge) provided the 0V connection is not grounded.

In applications where they may be exposed to high-energy voltage surges, some special measures may be required to prevent malfunction or damage. Surges may be caused by lightning or severe power faults in association with grounding arrangements which permit high transient voltages between nominally grounded points. This is a particular risk where the circuits extend outside the protection of a building.

As a general rule, if the circuits are to pass outside the building where the drive is located, or if cable runs within a building exceed 30 m, some additional precautions are advisable. One of the following techniques should be used:

1. Galvanic isolation, i.e. do not connect the control 0V terminal to ground. Avoid loops in the control wiring, i.e. ensure every control wire is accompanied by its return (0V) wire.
2. Shielded cable with additional power ground bonding. The cable shield may be connected to ground at both ends, but in addition the ground conductors at both ends of the cable must be bonded together by a power ground cable (equipotential bonding cable) with cross-sectional area of at least 10 mm², or 10 times the area of the signal cable shield, or to suit the electrical safety requirements of the plant. This ensures that fault or surge current passes mainly through the ground cable and not in the signal cable shield. If the building or plant has a well-designed common bonded network this precaution is not necessary.
3. Additional over-voltage suppression - for the analog and digital inputs and outputs, a zener diode network or a commercially available surge suppressor may be connected in parallel with the input circuit as shown in Figure 4-27 and Figure 4-28.

If a digital port experiences a severe surge its protective trip may operate (I/O Overload trip code 26). For continued operation after such an event, the trip can be reset automatically by setting Pr **10.034** to 5.

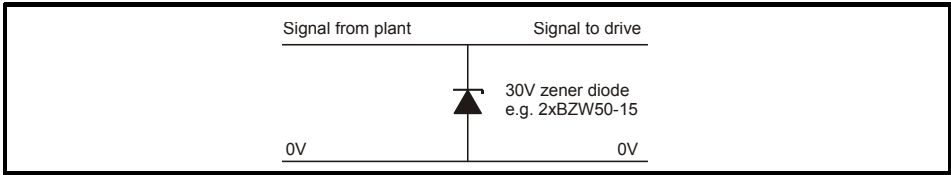
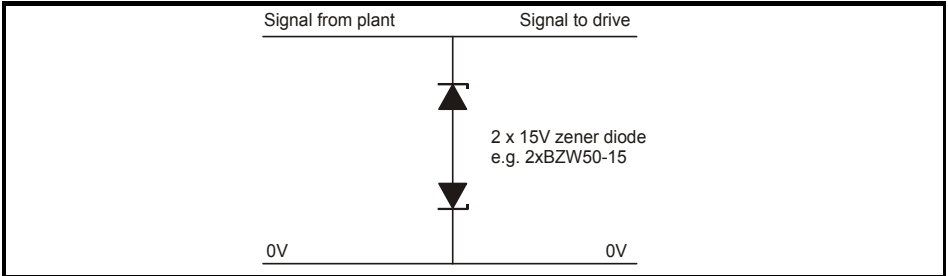
Figure 4-27 Surge suppression for digital and unipolar inputs and outputs**Figure 4-28 Surge suppression for analog and bipolar inputs and outputs**

Surge suppression devices are available as rail-mounting modules, e.g. from Phoenix Contact:

Unipolar TT-UKK5-D/24 DC

Bipolar TT-UKK5-D/24 AC

These devices are not suitable for encoder signals or fast digital data networks because the capacitance of the diodes adversely affects the signal. Most encoders have galvanic isolation of the signal circuit from the motor frame, in which case no precautions are required. For data networks, follow the specific recommendations for the particular network.

5 Technical data

5.1 Drive technical data

5.1.1 Power and current ratings

For a full explanation of 'Normal Duty' and 'Heavy Duty' refer to the *Control User Guide*.

The continuous current ratings given are for maximum 40 °C (104 °F), 1000 m altitude and 3 kHz switching frequency (unless stated otherwise). Derating is required for higher switching frequencies, ambient temperature >40 °C (104 °F) and high altitude. For further information, refer to *Power and current ratings (Derating for switching frequency and temperature)* on page 94.

Table 5-1 200 V drive ratings (200 V to 240 V ±10 %)

Model	Normal Duty				Heavy Duty				
	Max cont output current	Nominal power at 230 V	Motor power at 230 V	Peak current	Max cont output current	Open loop peak current	RFC peak current	Nominal power at 230 V	Motor power at 230 V
	A	kW	hp	A	A	A	A	kW	hp
07200610	75	18.5	25	82.5	61	91.5	122	15	20
07200750	94	22	30	103.4	75	112.5	150	18.5	25
07200830	117	30	40	128.7	83	124.5	166	22	30
08201160	149	37	50	163.9	116	174	232	30	40
08201320	180	45	60	198	132	198	264	37	50
09201760	216	55	75	237.6	176	264	308	45	60
09202190	266	75	100	292.6	219	328.5	383.25	55	75
10202830	325	90	125	357.5	283	424.5	495.25	75	100
10203000	360	110	150	396	300	450	525	90	125

Table 5-2 400 V drive ratings (380 V to 480 V ±10 %)

Model	Normal Duty				Heavy Duty				
	Max cont output current	Nominal power at 400 V	Motor power at 460 V	Peak current	Max cont output current	Open loop peak current	RFC peak current	Nominal power at 400 V	Motor power at 460 V
	A	kW	hp	A	A	A	A	kW	hp
07400660	79	37	60	86.9	66	99	132	30	50
07400770	94	45	60	103.4	77	115.5	154	37	60
07401000	112	55	75	123.2	100	150	200	45	75
08401340	155	75	100	170.5	134	201	268	55	100
08401570	184	90	150	202.4	157	235.5	314	75	125
09402000	221	110	150	243.1	200*	300	350	90	150
09402240	266*	132	200	292.6	224*	336	392	110	150
10402700	320	160	250	352	270	405	472.5	132	200
10403200	361	200	300	397.1	320*	480	560	160	250

* These ratings are for 2 kHz switching frequency. For ratings at 3 kHz switching frequency refer to section 5.1.2 *Power and current ratings (Derating for switching frequency and temperature)* on page 94.

Table 5-3 575 V drive ratings (500 V to 575 V $\pm 10\%$)

Model	Normal Duty				Heavy Duty				
	Max cont output current	Nominal power at 575 V	Motor power at 575 V	Peak current	Max cont output current	Open loop peak current	RFC peak current	Nominal power at 575 V	Motor power at 575 V
	A	kW	hp	A	A	A	A	kW	hp
07500440	53	45	50	58.3	44	66	88	30	40
07500550	73	55	60	80.3	55	82.5	110	37	50
08500630	86	75	75	94.6	63	94.5	126	45	60
08500860	108	90	100	118.8	86	129	172	55	75
09501040	125	110	125	137.5	104	156	182	75	100
09501310	150	110	150	165	131	196.5	229.25	90	125
10501520	200	130	200	220	152	228	266	110	150
10501900	200	150	200	220	190	285	332.5	132	200

Table 5-4 690 V drive ratings (500 V to 690 V $\pm 10\%$)

Model	Normal Duty				Heavy Duty				
	Max cont output current	Nominal power at 690 V	Motor power at 690 V	Peak current	Max cont output current	Open loop peak current	RFC peak current	Nominal power at 690 V	Motor power at 690 V
	A	kW	hp	A	A	A	A	kW	hp
07600190	23	18.5	25	25.3	19	28.5	38	15	20
07600240	30	22	30	33	24	36	48	18.5	25
07600290	36	30	40	39.6	29	43.5	58	22	30
07600380	46	37	50	50.6	38	57	76	30	40
07600440	52	45	60	57.2	44	66	88	37	50
07600540	73	55	75	80.3	54	81	108	45	60
08600630	86	75	100	94.6	63	94.5	126	55	75
08600860	108	90	125	118.8	86	129	172	75	100
09601040	125	110	150	137.5	104	156	182	90	125
09601310	155	132	175	170.5	131	196.5	229.25	110	150
10601500	172	160	200	189.2	150	225	262.5	132	175
10601780	197	185	250	216.7	178	267	311.5	160	200

5.1.2 Power and current ratings (Derating for switching frequency and temperature)

Table 5-5 Maximum permissible continuous output current @ 40 °C (104 °F) ambient

Model	Normal Duty								Heavy Duty									
	Nominal rating		Maximum permissible continuous output current (A) for the following switching frequencies						Nominal rating		Maximum permissible continuous output current (A) for the following switching frequencies							
	kW	hp	2 kHz*	3 kHz	4 kHz	6 kHz	8 kHz	12 kHz	16 kHz	kW	hp	2 kHz*	3 kHz	4 kHz	6 kHz	8 kHz	12 kHz	16 kHz
200 V																		
07200610	18.5	25	75				74.3	59.7	15	20	61						53.1	
07200750	22	30	94				74.3	59.7	18.5	25	75				65.3	53.1		
07200830	30	40	117		114	96	74.3	59.7	22	30	83			80.5	65.6	53.1		
08201160	37	50	149			146	125.2	93	30	40	116		113.7	103	89.3	80.5		
08201320	45	60	180		160.2	148.8	126	93	37	50	132	126.7	114	103	89.8	80.5		
09201760	55	75	216			184	128	93	45	60	176			153	110	81		
09202190	75	100	266	258	218	184	128	93	55	75	219	212	180	153	110	81		
10202830	90	125	325		313	266	194	144	75	100	283		264	228	170	127		
10203000	110	150	360		313	266	194	144	90	125	300		264	228	171	129		
400 V																		
07400660	37	60	79				63	53.6	30	50	66			57	48	41	34	
07400770	45	60	94			80.6	63	53.6	37	60	77	70	59	51	44	37		
07401000	55	75	112		95.2	80.6	63	53.8	45	75	100	88	73	61	48	41		
08401340	75	100	155			132	98	77	55	100	134	130	109	91	72	57		
08401570	90	150	184		169	142	106.7	77	75	125	157	143	121	104	80.1	65		
09402000	110	150	221			192	159	108	77	90	150	200	180	157	130	92	65	
09402240	132	200	266	255	231	192	160	109	77	110	150	224	211	190	157	130	92	65
10402700	160	250	320		285	238	173	124	132	200	270		237	200	147	108		
10403200	200	300	361	339	285	238	173	126	160	250	320	307	282	237	202	147	109	
575 V																		
07500440	45	50	53			51.8	40.2	27.7	21.2	30	40	44		39.2	30.8	21.6	16.7	
07500550	55	60	73	71.5	51.8	40.2	27.7	21.2	37	50	55	52.8	39.2	30.8	21.6	17.1		
08500630	75	75	86			73.1	49.7	37.8	45	60	63			53.3	37.2	28.4		
08500860	90	100	108		91.8	73.1	49.7	37.8	55	75	86		67.1	53.3	37.8	28.4		
09501040	110	125	125			101	71	54	75	100	104			85	61	47		
09501310	110	150	150		126	100	70	54	90	125	131		106	85	61	47		
10501520	130	200	200	168	126	100	70	54	110	150	152	138	106	85	61	47		

Model	Normal Duty								Heavy Duty									
	Nominal rating		Maximum permissible continuous output current (A) for the following switching frequencies						Nominal rating		Maximum permissible continuous output current (A) for the following switching frequencies							
	kW	hp	2 kHz*	3 kHz	4 kHz	6 kHz	8 kHz	12 kHz	16 kHz	kW	hp	2 kHz*	3 kHz	4 kHz	6 kHz	8 kHz	12 kHz	16 kHz
10501900	150	200	200			152	116	76	54	132	200	190	190	186	137	106	70	51
690 V																		
07600190	18.5	25	23					21.2	15	20	19					16.7		
07600240	22	30	30				27.9	21.2	18.5	25	24				21.8	16.6		
07600290	30	40	36				28.1	21.2	22	30	29				21.8	16.5		
07600380	37	50	46			40.5	28.1	21.2	30	40	38			30.8	21.7	16.7		
07600440	45	60	52		51.5	40.6	28.1	21.2	37	50	44		38.7	30.8	21.6	16.7		
07600540	55	75	73	71.5	51.8	40.6	28.1	21.2	45	60	54	52.9	39	31	21.6	16.7		
08600630	75	100	86			72.2	49.7	37.8	55	75	63			53.3	37	28.4		
08600860	90	125	108		91.8	72.4	49.7	37.8	75	100	86		67.1	53.3	37	28.4		
09601040	110	150	125			100	71	54	90	125	104			85	61	47		
09601310	132	175	155		126	100	71	54	110	150	131		105	85	62	47		
10601500	160	200	172	169	126	100	71	55	132	175	150	138	105	86	62	47		
10601780	185	250	197		154	114	75	55	160	200	178		137	105	69	52		

* For Unidrive M200 to M400 the 0.667 and 1 kHz value is the same as the 2 kHz value.

Safety information

Product information

Mechanical installation

Electrical installation

Technical data

UL listing information

Table 5-6 Maximum permissible continuous output current @ 50 °C (122 °F)

Model	Normal Duty							Heavy Duty							
	Maximum permissible continuous output current (A) for the following switching frequencies							Maximum permissible continuous output current (A) for the following switching frequencies							
	2 kHz*	3 kHz	4 kHz	6 kHz	8 kHz	12 kHz	16 kHz	2 kHz*	3 kHz	4 kHz	6 kHz	8 kHz	12 kHz	16 kHz	
200 V															
07200610	75						59.7	48.8	61					53.1	43.2
07200750	94			92.1	80	59.7	48.9	75				69.8	53.1	43.2	
07200830	117		112	92.4	80	59.7	49.1	83			81.3	69.7	53.1	43.2	
08201160	149			147	133	113	84	116			104	95.1	81.8	72	
08201320	180		167	148	133	113	84	132	125	117	104	95.1	81.8	72	
09201760	216			197	168	117	84	176			165	140	100	72	
09202190	253	237	221	197	168	117	85	219	210	195	166	140	101	72	
10202830	325	320	302	266	241	176	130	283		279	241	207	153	114	
10203000	346	320	302	266	241	176	130	300		279	243	207	153	114	
400 V															
07400660	79				73.5	57.7	49	66			55	45	38	30	
07400770	94			86.5	73.3	58.3	49	77		70	57	48	41	34	
07401000	112		109	87.4	72.8	58.3	49.3	100	91	80	65	55	44	37	
08401340	155			146	123	93	69	134		120	99	85	69	55	
08401570	184		180	146	123	93.8	69	157	146	132	110	94.2	73.8	58	
09402000	221		213	175	144	97	69	200	180	174	143	119	83	58	
09402240	253	237	213	176	144	98	69	213	193	175	143	119	83	58	
10402700	320		300	259	217	154	112	270		259	214	182	131	97	
10403200	343	321	300	260	217	155	112	307	282	259	214	182	131	99	
575 V															
07500440	53			46.7	35.8	24.8	19	44			35.2	28.1	19.3	15	
07500550	73		65	46.7	35.8	24.8	19	55		48.4	35.2	28.1	19.3	15	
08500630	86			76.7	64.5	44.3	31.3	63			61.1	48.5	33.4	24.9	
08500860	104	97.2	90.7	76.7	64.8	44.3	31.3	86		80.8	61.1	49	33.4	24.9	
09501040	125			114	90	62	48	104			97	77	55	42	
09501310	150			114	90	62	48	131		126	97	77	55	42	
10501520	200	184	154	114	90	62	48	152	150	126	97	78	55	43	
10501900	200		196	134	102	66	48	190		171	124	95	63	46	

Model	Normal Duty							Heavy Duty						
	Maximum permissible continuous output current (A) for the following switching frequencies							Maximum permissible continuous output current (A) for the following switching frequencies						
	2 kHz*	3 kHz	4 kHz	6 kHz	8 kHz	12 kHz	16 kHz	2 kHz*	3 kHz	4 kHz	6 kHz	8 kHz	12 kHz	16 kHz
690 V														
07600190	23						19	19						14.5
07600240	30					24.8	19	24					19.4	14.5
07600290	36				35.8	24.8	19	29				27.7	19.4	14.5
07600380	46				35.8	24.8	19	38			35.3	27.7	19.4	14.5
07600440	52			46.7	35.8	25	19	44			35.6	27.7	19.4	14.5
07600540	73	65	46.7	35.8	25	19	54	48.1	35.6	27.7	19.4	14.6		
08600630	86			76.7	64.5	44.3	31.3	63			61.1	48.2	33.4	24.9
08600860	104	97.2	90.7	76.7	64.8	44.3	31.3	86	80.8	61.1	48.2	33.5	24.9	
09601040	125			114	90	62	48	104			97	77	55	42
09601310	155	153	113	89	62	48	131	127	97	77	55	42		
10601500	172	153	114	89	62	48	150	128	96	78	56	42		
10601780	197	195	134	102	67	48	178	171	125	94	62	44		

* For *Unidrive* M200 to M400 the 0.667 and 1 kHz value is the same as the 2 kHz value.

NOTE 55 °C ratings are available on request

5.1.3 Power dissipation

Table 5-7 Losses @ 40° C (104° F) ambient

Model	Normal Duty									Heavy Duty								
	Nominal rating		Drive losses (W) taking into account any current derating for the given conditions							Nominal rating		Drive losses (W) taking into account any current derating for the given conditions						
	kW	hp	2 kHz*	3 kHz	4 kHz	6 kHz	8 kHz	12 kHz	16 kHz	kW	hp	2 kHz*	3 kHz	4 kHz	6 kHz	8 kHz	12 kHz	16 kHz
200 V																		
07200610	18.5	25	533	570	597	650	703	885	894	15	20	433	466	488	532	575	666	715
07200750	22	30	671	718	751	815	881	890	899	18.5	25	529	570	597	650	703	710	717
07200830	30	40	851	911	951	1004	911	920	929	22	30	589	634	663	720	755	763	770
08201160	37	50	1339	1433	1536	1765	1943	1962	1982	30	40	1026	1105	1193	1343	1373	1387	1401
08201320	45	60	1638	1753	1894	1914	1985	2005	2025	37	50	1260	1269	1306	1349	1372	1386	1400
09201760 (9A)	55	75	2028	2170	2312	2596	2448	2160	2031	45	60	1580	1701	1822	2065	2022	1881	1820
09202190 (9A)	75	100	2585	2754	2822	2623	2448	2156	2034	55	75	2016	2160	2227	2107	2025	1874	1821
09201760 (9E)	55	75	1889	2031	2174	2458	2348	2112	2006	45	60	1488	1609	1730	1973	1952	1845	1801
09202190 (9E)	75	100	2375	2554	2625	2482	2348	2108	2009	55	75	1874	2017	2093	2011	1956	1839	1802
10202830	90	125	2478	2672	2867	3123	2952	2701	2554	75	100	2068	2240	2413	2561	2494	2376	2303
10203000	110	150	2802	3016	3230	3126	2957	2706	2554	90	125	2213	2394	2576	2561	2494	2389	2323
400 V																		
07400660	37	60	745	830	907	1062	1218	1230	1242	30	50	616	692	758	773	763	771	778
07400770	45	60	896	999	1088	1264	1241	1253	1266	37	60	723	812	802	800	811	819	827
07401000	55	75	1033	1152	1247	1218	1170	1182	1194	45	75	906	1017	968	936	907	916	925
08401340	75	100	1482	1652	1817	2154	2121	2142	2164	55	100	1224	1374	1509	1521	1510	1525	1540
08401570	90	150	1798	2004	2191	2333	2279	2302	2325	75	125	1373	1541	1670	1674	1673	1690	1707
09402000 (9A)	110	150	2431	2710	2989	3075	2992	2842	2833	90	150	2132	2136	2370	2492	2475	2501	2538
09402240 (9A)	132	200	3016	3191	3143	3063	3000	2856	2828	110	150	2424	2532	2511	2489	2474	2498	2537
09402000 (9E)	110	150	2286	2565	2844	2966	2917	2807	2815	90	150	2014	2039	2274	2418	2425	2476	2526
09402240 (9E)	132	200	2806	2998	2984	2955	2925	2821	2811	110	150	2275	2400	2403	2416	2424	2473	2525
10402700	160	250	3210	3582	3954	4148	4034	3939	3843	132	200	2604	2923	3242	3401	3391	3438	3469
10403200	200	300	3703	4121	4226	4154	4038	3947	3874	160	250	3166	3376	3393	3398	3419	3442	3485
575 V																		
07500440	45	50	867	1004	1139	1358	1262	1275	1287	30	40	700	817	929	1028	967	977	986
07500550	55	60	1078	1248	1375	1209	1122	1133	1145	37	50	759	886	1002	914	863	872	880
08500630	75	75	1607	1861	2180	2814	2982	3012	3042	45	60	1153	1345	1585	2136	2284	2307	2330
08500860	90	100	2050	2374	2753	2947	2963	2993	3023	55	75	1554	1813	2174	2212	2218	2240	2263

Model	Normal Duty									Heavy Duty								
	Nominal rating		Drive losses (W) taking into account any current derating for the given conditions							Nominal rating		Drive losses (W) taking into account any current derating for the given conditions						
	kW	hp	2 kHz*	3 kHz	4 kHz	6 kHz	8 kHz	12 kHz	16 kHz	kW	hp	2 kHz*	3 kHz	4 kHz	6 kHz	8 kHz	12 kHz	16 kHz
09501040 (9A)	110	125	1707	1977	2247	2787	2723	2731	2859	75	100	1372	1601	1830	2288	2305	2422	2603
09501310 (9A)	110	150	2087	2410	2734	2810	2692	2697	2859	90	125	1752	2034	2316	2332	2302	2412	2607
09501040 (9E)	110	125	1595	1865	2135	2675	2644	2687	2831	75	100	1290	1519	1748	2206	2246	2387	2580
09501310 (9E)	110	150	1933	2256	2580	2696	2616	2654	2831	90	125	1630	1913	2195	2247	2244	2378	2584
10501520	130	200	2692	3137	2923	2696	2616	2654	2831	110	150	1917	2245	2324	2253	2243	2373	2583
10501900	150	200	2384	2797	3209	3072	2946	2990	3189	132	200	2213	2605	2933	2750	2713	2818	3076
690 V																		
07600190	18.5	25	363	428	491	617	743	793	970	15	20	303	360	413	519	625	683	790
07600240	22	30	468	551	631	791	952	962	971	18.5	25	375	446	513	644	776	784	792
07600290	30	40	560	660	754	941	1129	1140	1152	22	30	449	533	610	765	920	929	938
07600380	37	50	725	854	971	1206	1271	1284	1297	30	40	587	697	796	993	966	976	985
07600440	45	60	836	985	1117	1350	1275	1288	1301	37	50	687	817	929	1015	967	977	986
07600540	55	75	1059	1248	1375	1209	1122	1133	1145	45	60	747	888	1004	909	869	878	886
08600630	75	100	1579	1861	2180	2814	2945	2974	3004	55	75	1132	1345	1585	2136	2284	2307	2330
08600860	90	125	2015	2374	2753	2947	2935	2964	2994	75	100	1526	1813	2174	2212	2218	2240	2263
09601040 (9A)	110	150	1878	2213	2548	3218	3155	3266	3465	90	125	1513	1798	2083	2653	2714	2910	3161
09601310 (9A)	132	175	2384	2797	3211	3232	3155	3267	3474	110	150	1931	2281	2631	2677	2711	2917	3174
09601040 (9E)	110	150	1730	2065	2400	3070	3058	3215	3434	90	125	1409	1694	1979	2549	2643	2872	3138
09601310 (9E)	132	175	2160	2573	2986	3083	3058	3216	3443	110	150	1769	2119	2469	2571	2639	2878	3150
10601500	160	200	2420	2882	3270	3083	3052	3192	3472	132	175	2042	2441	2604	2571	2648	2876	3128
10601780	185	250	2614	3132	3649	3667	3495	3633	3993	160	200	2305	2774	3242	3265	3237	3442	3839

Safety information

Product information

Mechanical installation

Electrical installation

Technical data

UL listing information

Table 5-8 Losses @ 50° C (122° F) ambient

Model	Normal Duty							Heavy Duty						
	Drive losses (W) taking into account any current derating for the given conditions							Drive losses (W) taking into account any current derating for the given conditions						
	2 kHz*	3 kHz	4 kHz	6 kHz	8 kHz	12 kHz	16 kHz	2 kHz*	3 kHz	4 kHz	6 kHz	8 kHz	12 kHz	16 kHz
200 V														
07200610	538	570	597	650	703	710	717	430	466	488	532	575	581	587
07200750	678	718	751	799	750	758	765	526	570	597	650	654	661	667
07200830	848	898	898	805	751	759	766	585	634	663	705	653	660	666
08201160	1353	1433	1536	1741	1770	1788	1806	1020	1105	1193	1228	1277	1290	1303
08201320	1640	1737	1740	1759	1771	1789	1807	1110	1202	1206	1228	1278	1291	1304
09201760 (9A)	2028	2170	2312	2354	2256	2010	1910	1580	1701	1822	1943	1867	1757	1700
09202190 (9A)	2431	2405	2368	2358	2245	2015	1922	2016	2063	2029	1954	1868	1763	1701
09201760 (9E)	1889	2031	2174	2240	2172	1970	1889	1488	1609	1730	1862	1808	1728	1684
09202190 (9E)	2241	2239	2223	2243	2161	1975	1900	1874	1932	1916	1872	1810	1733	1686
10202830	2478	2625	2641	2625	2671	2490	2379	2068	2240	2375	2326	2271	2185	2141
10203000	2666	2629	2643	2629	2678	2495	2374	2213	2394	2375	2350	2275	2187	2141
400 V														
07400660	744	830	907	1062	1141	1152	1164	616	692	758	751	725	732	740
07400770	895	999	1087	1163	1138	1149	1161	720	808	804	779	773	781	789
07401000	1018	1136	1200	1118	1074	1085	1096	821	922	878	838	828	836	845
08401340	1480	1652	1815	2016	1970	1990	2010	1256	1410	1392	1391	1432	1446	1461
08401570	1754	1957	2114	1998	1979	1999	2019	1393	1564	1539	1518	1531	1546	1562
09402000 (9A)	2431	2710	2872	2799	2737	2639	2652	2132	2136	2290	2289	2305	2342	2399
09402240 (9A)	2837	2926	2870	2814	2737	2660	2665	2286	2294	2300	2294	2300	2340	2404
09402000 (9E)	2286	2565	2738	2709	2675	2611	2638	2014	2039	2200	2228	2262	2322	2389
09402240 (9E)	2648	2760	2735	2723	2675	2632	2651	2152	2184	2209	2233	2258	2320	2394
10402700	3210	3582	3681	3765	3700	3597	3591	2604	2923	3105	3081	3125	3165	3262
10403200	3482	3598	3676	3776	3694	3625	3589	3018	3062	3105	3087	3131	3168	3300
575 V														
07500440	936	988	1115	1225	1144	1155	1167	705	817	923	923	898	907	916
07500550	1161	1225	1228	1098	1030	1040	1051	797	923	914	828	809	817	825
08500630	1753	1850	2172	2540	2672	2699	2726	1161	1345	1585	2292	2242	2264	2287
08500860	1980	2090	2291	2540	2684	2711	2738	1593	1845	2029	2039	2047	2067	2088
09501040 (9A)	1707	1977	2247	2538	2456	2495	2699	1372	1601	1830	2139	2122	2258	2455
09501310 (9A)	2087	2410	2734	2544	2456	2482	2676	1752	2034	2222	2143	2128	2258	2453

Model	Normal Duty							Heavy Duty						
	Drive losses (W) taking into account any current derating for the given conditions							Drive losses (W) taking into account any current derating for the given conditions						
	2 kHz*	3 kHz	4 kHz	6 kHz	8 kHz	12 kHz	16 kHz	2 kHz*	3 kHz	4 kHz	6 kHz	8 kHz	12 kHz	16 kHz
09501040 (9E)	1595	1865	2135	2443	2392	2460	2674	1290	1519	1748	2067	2072	2229	2436
09501310 (9E)	1933	2256	2580	2448	2392	2447	2652	1630	1913	2109	2071	2078	2229	2434
10501520	2692	2841	2654	2448	2392	2447	2652	1917	2220	2112	2077	2083	2222	2452
10501900	2384	2797	3141	2743	2672	2766	3036	2213	2605	2686	2516	2496	2651	2933
690 V														
07600190	359	428	491	617	743	750	758	301	360	413	519	625	631	638
07600240	463	551	631	791	958	968	977	373	446	513	644	776	784	792
07600290	554	660	754	944	1144	1155	1167	446	533	610	765	809	817	825
07600380	717	854	965	1206	1144	1155	1167	583	697	796	926	885	894	903
07600440	814	969	1094	1225	1144	1155	1167	683	817	923	933	885	894	903
07600540	1029	1225	1228	1098	1030	1040	1051	758	906	908	837	797	805	813
08600630	1553	1850	2172	2540	2672	2699	2726	1125	1345	1585	2292	2229	2251	2274
08600860	1755	2090	2291	2540	2684	2711	2738	1543	1845	2029	2039	2014	2034	2054
09601040 (9A)	1878	2213	2548	2933	2882	2974	3248	1513	1798	2083	2483	2502	2721	2994
09601310 (9A)	2384	2797	3175	2918	2855	2974	3249	1931	2281	2548	2488	2509	2718	2991
09601040 (9E)	1730	2065	2400	2810	2803	2934	3223	1409	1694	1979	2392	2443	2690	2974
09601310 (9E)	2160	2573	2955	2796	2778	2934	3225	1769	2119	2395	2397	2450	2687	2972
10601500	2420	2882	2947	2805	2789	2932	3229	2042	2441	2403	2377	2467	2701	2974
10601780	2614	3132	3610	3243	3221	3420	3771	2305	2774	3111	3007	2996	3253	3621

* For Unidrive M200 to M400 the 0.667 and 1 kHz value is the same as the 2 kHz value.

Table 5-9 Power losses from the front of the drive when through-panel mounted

Frame size	Power loss
7	≤ 204 W
8	≤ 347 W
9	≤ 480 W
10	≤ 480 W

5.1.4 Temperature, humidity and cooling method

Ambient temperature operating range:

- 20 °C to 55 °C (- 4 °F to 131 °F).

Output current derating must be applied at ambient temperatures >40 °C (104 °F).

Cooling method: Forced convection

Maximum humidity: 95 % non-condensing at 40 °C (104 °F)

5.1.5 AC Supply requirements

AC supply voltage:

200 V drive: 200 V to 240 V ± 10 %

400 V drive: 380 V to 480 V ± 10 %

575 V drive: 500 V to 575 V ± 10 %

690 V drive: 500 V to 690 V ± 10 %

Number of phases: 3

Maximum supply imbalance: 2 % negative phase sequence (equivalent to 3 % voltage imbalance between phases).

Frequency range: 45 to 66 Hz

For UL compliance only, the maximum supply symmetrical fault current must be limited to 100 kA

5.1.6 Motor requirements

No. of phases: 3

Maximum voltage:

200 V drive: 265 V

400 V drive: 530 V

575 V drive: 635 V

690 V drive: 765 V

5.1.7 Storage

-40 °C (-40 °F) to +55 °C (131 °F) for long term storage, or to +70 °C (158 °F) for short term storage.

Storage time is 2 years.

Electrolytic capacitors in any electronic product have a storage period after which they require reforming or replacing.

The DC bus capacitors have a storage period of 10 years.

The low voltage capacitors on the control supplies typically have a storage period of 2 years and are thus the limiting factor.

Low voltage capacitors cannot be reformed due to their location in the circuit and thus may require replacing if the drive is stored for a period of 2 years or greater without power being applied.

It is therefore recommended that drives are powered up for a minimum of 1 hour after every 2 years of storage. This process allows the drive to be stored for a further 2 years.

5.1.8 Altitude

Altitude range: 0 to 3,000 m (9,900 ft), subject to the following conditions:

1,000 m to 3,000 m (3,300 ft to 9,900 ft) above sea level: de-rate the maximum output current from the specified figure by 1% per 100 m (330 ft) above 1,000 m (3,300 ft)

For example at 3,000 m (9,900 ft) the output current of the drive would have to be de-rated by 20 %.

5.1.9 IP / UL Rating

The drive is rated to IP20 pollution degree 2 (dry, non-conductive contamination only) (NEMA 1).

However, it is possible to configure the drive to achieve IP65 rating (sizes 7 and 8) or IP55 rating (size 9 and 10) (NEMA 12) at the rear of the heatsink for through-panel mounting .

The IP rating of a product is a measure of protection against ingress and contact to foreign bodies and water. It is stated as IP XX, where the two digits (XX) indicate the degree of protection provided as shown in Table 5-10.

Table 5-10 IP Rating degrees of protection

First digit		Second digit	
Protection against foreign bodies and access to hazardous parts		Protection against ingress of water	
0	Non-protected	0	Non-protected
1	Protected against solid foreign objects of 50 mm \varnothing and greater (back of a hand)	1	Protected against vertically falling water drops
2	Protected against solid foreign objects of 12.5mm \varnothing and greater (finger)	2	Protected against vertically falling water drops when enclosure tilted up to 15 °
3	Protected against solid foreign objects of 2.5 mm \varnothing and greater (tool)	3	Protected against spraying water
4	Protected against solid foreign objects of 1.0mm \varnothing and greater (wire)	4	Protected against splashing water
5	Dust-protected (wire)	5	Protected against water jets
6	Dust-tight (wire)	6	Protected against powerful water jets
7	-	7	Protected against the effects of temporary immersion in water
8	-	8	Protected against the effects of continuous immersion in water

Table 5-11 UL enclosure ratings

UL rating	Description
Type 1	Enclosures are intended for indoor use, primarily to provide a degree of protection against limited amounts of falling dirt.
Type 12	Enclosures are intended for indoor use, primarily to provide a degree of protection against dust, falling dirt and dripping non-corrosive liquids.

5.1.10 Corrosive gasses

Unidrive M600 to M702:

Concentrations of corrosive gases must not exceed the levels given in:

- Table A2 of EN 50178:1998
- Class 3C2 of IEC 60721-3-3

This corresponds to the levels typical of urban areas with industrial activities and/or heavy traffic, but not in the immediate neighborhood of industrial sources with chemical emissions.

Unidrive M200 to M400:

Concentrations of corrosive gases must not exceed the levels given in:

- Table A2 of EN 50178:1998

Printed Circuit Board & Component Solder technology of M200-400 are conformal coated to survive environments as described by IEC60721-3-3 3C3 and EN60068-2-60 Meth. 4. This corresponds to the levels typical of urban areas with industrial activities and/or heavy traffic and in the immediate neighborhood of industrial sources with chemical emissions.

5.1.11 RoHS compliance

The drive meets EU directive 2011/65/EU for RoHS compliance.

5.1.12 Vibration

Maximum recommended continuous vibration level 0.14 g r.m.s. broad-band 5 to 200 Hz.

NOTE

This is the limit for broad-band (random) vibration. Narrow-band vibration at this level which coincides with a structural resonance could result in premature failure.

Bump Test

Testing in each of three mutually perpendicular axes in turn.

Referenced standard: IEC 60068-2-29: Test Eb:

Severity: 18 g, 6 ms, half sine

No. of Bumps: 600 (100 in each direction of each axis)

Random Vibration Test

Testing in each of three mutually perpendicular axes in turn.

Referenced standard: IEC 60068-2-64: Test Fh:

Severity: $1.0 \text{ m}^2/\text{s}^3$ ($0.01 \text{ g}^2/\text{Hz}$) ASD from 5 to 20 Hz

-3 dB/octave from 20 to 200 Hz

Duration: 30 minutes in each of 3 mutually perpendicular axes.

Sinusoidal Vibration Test

Testing in each of three mutually perpendicular axes in turn.

Referenced standard: IEC 60068-2-6: Test Fc:

Frequency range: 5 to 500 Hz

Severity: 3.5 mm peak displacement from 5 to 9 Hz

10 m/s^2 peak acceleration from 9 to 200 Hz

15 m/s^2 peak acceleration from 200 to 500 Hz

Sweep rate: 1 octave/minute

Duration: 15 minutes in each of 3 mutually perpendicular axes.

EN 61800-5-1:2007, Section 5.2.6.4. referring to IEC 60068-2-6

Frequency range: 10 to 150 Hz

Amplitude: 10 to 57 Hz at 0.075 mm pk

57 to 150 Hz at 1g p

Sweep rate: 1 octave/minute

Duration: 10 sweep cycles per axis in each of 3 mutually perpendicular axes

5.1.13 Starts per hour

By electronic control: unlimited

By interrupting the AC supply: ≤ 20 (equally spaced)

5.1.14 Start up time

This is the time taken from the moment of applying power to the drive, to the drive being ready to run the motor:

Size 7 to 10: 5s

For faster start up time a 24V backup supply can be used, see section 4.4 *24 Vdc supply* on page 63

5.1.15 Output frequency / speed range**Unidrive Mxxx models:**

In all operating modes (Open loop, RFC-A, RFC-S) the maximum output frequency is limited to 550 Hz.

Unidrive HSxx models:

In open loop mode the maximum achievable output frequency is 3,000 Hz.

In RFC-A and RFC-S modes, the maximum achievable output frequency is 1,250Hz.

In RFC-S mode the speed is also limited by the voltage constant (K_e) of the motor unless field weakening operation is enabled. K_e is a specific constant for the servo motor being used. It can normally be found on the motor data sheet in V/k rpm (volts per 1,000 rpm).

It is recommended that a minimum ratio of 12:1 is maintained between the switching frequency and the maximum output frequency to maintain the quality of the output waveform. If this minimum ratio is exceeded, extra motor losses will result due to the increased harmonic content of the output waveform.

5.1.16 Accuracy and resolution

Unidrive M600 to M702:

Speed:

The absolute frequency and speed accuracy depends on the accuracy of the crystal used with the drive microprocessor. The accuracy of the crystal is 100 ppm, and so the absolute frequency/speed accuracy is 100 ppm (0.01 %) of the reference, when a preset speed is used. If an analog input is used the absolute accuracy is further limited by the absolute accuracy of the analog input.

The following data applies to the drive only; it does not include the performance of the source of the control signals.

Open loop resolution:

Preset frequency reference: 0.1 Hz

Precision frequency reference: 0.001 Hz

Closed loop resolution

Preset speed reference: 0.1 rpm

Precision speed reference: 0.001 rpm

Analog input 1: 11 bit plus sign (not applicable to *Unidrive M702*)

Analog input 2: 11 bit plus sign (not applicable to *Unidrive M702*)

Current:

The resolution of the current feedback is 10 bit plus sign.

Accuracy: typical 2 %

worst case 5 %

Unidrive M200 to M400:

Frequency:

The absolute frequency accuracy depends on the accuracy of the oscillator used with the drive microprocessor. The accuracy of the oscillator is ± 0.02 %, and so the absolute frequency accuracy is ± 0.02 % of the reference, when a preset frequency is used. If an analog input is used, the absolute accuracy is further limited by the absolute accuracy of the analog input.

The following data applies to the drive only; it does not include the performance of the source of the control signals.

Open & closed loop resolution:

Preset frequency reference: 0.01 Hz

Analog input 1: 11 bit plus sign

Analog input 2: 11 bit

Current:

The resolution of the current feedback is 10 bit plus sign.

Accuracy: typical 2 %

worst case 5 %

5.1.17 Acoustic noise

The heatsink fan generates the majority of the sound pressure level at 1 m produced by the drive. The heatsink fan is a variable speed fan. The drive controls the speed at which the fan runs based on the temperature of the heatsink and the drive's thermal model system.

Table 5-12 gives the sound pressure level at 1 m produced by the drive for the heatsink fan running at the maximum and minimum speeds.

Table 5-12 Acoustic noise data

Size	Max speed dBA	Min speed dBA
7	66.8	49.6
8	67.9	49.8
9	75	52.6
10	75	52.6

5.1.18 Overall dimensions

- H1 Height including surface mounting brackets
- H2 Height excluding surface mounting brackets
- W Width
- D Depth (Projection forward of panel when surface mounted)

Table 5-13 Overall drive dimensions

Size	H1		H2		W		D	
	mm	in	mm	in	mm	in	mm	in
7	557	21.93	508	20	270	10.63	280	11.02
8	804	31.65	753	29.65	310	12.21	290	11.42
9E and 10E	1069	42.09	1010	39.70	310	12.21	290	11.42
9A	1108	43.61	1049	41.30	310	12.21	290	11.42

5.1.19 Weights

Table 5-14 Overall drive weights

Size	Model	kg	lb
7	All variants	28	61.70
8	All variants	52	114.64
9A	All variants	66.5	146.60
9E	All variants	46	101.40
10E	All variants		

5.1.20 Input current, fuse and cable size ratings

The input current is affected by the supply voltage and impedance.

Typical input current

The values of typical input current are given to aid calculations for power flow and power loss.

The values of typical input current are stated for a balanced supply.

Maximum continuous input current

The values of maximum continuous input current are given to aid the selection of cables and fuses. These values are stated for the worst case condition with the unusual combination of stiff supply with bad balance. The value stated for the maximum continuous input current would only be seen in one of the input phases. The current in the other two phases would be significantly lower.

The values of maximum input current are stated for a supply with a 2 % negative phase-sequence imbalance and rated at the maximum supply fault current of 100kA.

Table 5-15 AC Input current and fuse ratings (200 V)

Model	Typical input current A	Maximum continuous input current A	Maximum overload input current A	Fuse rating					
				IEC			UL / USA		
				Nominal A	Max A	Class	Nominal A	Max A	Class
07200610	58	67	109	80	80	gG	80	80	CC, J or T*
07200750	73	84	135	100	100		100	100	
07200830	91	105	149	125	125		125	125	
08201160	123	137	213	200	200	gR	200	200	HSJ
08201320	149	166	243				225	225	
09201760	172	205	270	250	250	gR	250	250	HSJ
09202190	228	260	319	315	315		300	300	
10202830	277	305	421	400	400	gR	400	400	HSJ
10203000	333	361	494	450	450		450	450	

Table 5-16 AC Input current and fuse ratings (400 V)

Model	Typical input current A	Maximum continuous input current A	Maximum overload input current A	Fuse rating					
				IEC			UL / USA		
				Nominal A	Max A	Class	Nominal A	Max A	Class
07400660	67	74	124	100	100	gG	80	80	CC, J or T*
07400770	80	88	145				100	100	
07401000	96	105	188				125	125	
08401340	137	155	267	250	250	gR	225	225	HSJ
08401570	164	177	303				225	225	
09402000	211	232	306	315	315	gR	300	300	HSJ
09402240	245	267	359				350	350	
10402700	306	332	445	400	400	gR	400	400	HSJ
10403200	370	397	523	450	450		450	450	

* These fuses are fast acting.

Table 5-17 AC Input current and fuse ratings (575 V)

Model	Typical input current A	Maximum continuous input current A	Maximum overload input current A	Fuse rating					
				IEC			UL / USA		
				Nominal A	Max A	Class	Nominal A	Max A	Class
07500440	41	45	75	50	50	gG	50	50	CC, J or T*
07500550	57	62	94	80	80		80	80	
08500630	74	83	121	125	125	gR	100	100	HSJ
08500860	92	104	165	160	160		150	150	
09501040	145	166	190	150	150	gR	150	150	HSJ
09501310	145	166	221	200	200		175	175	
10501520	177	197	266	250	250	gR	250	250	HSJ
10501900	199	218	310						

Table 5-18 AC Input current and fuse ratings (690 V)

Model	Typical input current A	Maximum continuous input current A	Maximum overload input current A	Fuse rating					
				IEC			UL / USA		
				Nominal A	Max A	Class	Nominal A	Max A	Class
07600190	18	20	32	25	50	gG	25	50	CC, J or T*
07600240	23	26	41	32					
07600290	28	31	49	40					
07600380	36	39	65	50					
07600440	40	44	75	80					
07600540	57	62	92	80	80	80	80		
08600630	74	83	121	125	125	gR	100	100	HSJ
08600860	92	104	165	160	160		150	150	
09601040	124	149	194	150	150	gR	150	150	HSJ
09601310	145	171	226	200	200		200	200	
10601500	180	202	268	225	225	gR	250	250	HSJ
10601780	202	225	313	250	250	gR	250	250	

* These fuses are fast acting.



The nominal cable sizes below are only a guide. The mounting and grouping of cables affects their current-carrying capacity, in some cases smaller cables may be acceptable but in other cases a larger cable is required to avoid excessive temperature or voltage drop. Refer to local wiring regulations for the correct size of cables.

Table 5-19 Cable ratings (200 V)

Model	Cable size (IEC) mm ²						Cable size (UL) AWG or Kcmil			
	Input			Output			Input		Output	
	Nominal	Max	Install method	Nominal	Max	Install method	Nominal	Max	Nominal	Max
07200610	35	70	B2	35	70	B2	2	1/0	2	1/0
07200750				70			1		1	
07200830	70			70			1/0		1/0	
08201160	95	2 x 70	B2	95	2 x 70	B2	3/0	2 x 1	3/0	2 x 1
08201320	2 x 70			2 x 70			2 x 1		2 x 1	
09201760	2 x 70	2 x 185	B1	2 x 95	2 x 150	B2	2 x 2/0	2 x 500	2 x 2/0	2 x 350
09202190	2 x 95	2 x 185		2 x 120	2 x 150		2 x 4/0	2 x 500	2 x 4/0	2 x 350
10202830	2 x 120	2 x 185	B1	2 x 120	2 x 150	C	2 x 250	2 x 500	2 x 250	2 x 350
10203000	2 x 150	2 x 185	C	2 x 120	2 x 150		2 x 300	2 x 500	2 x 250	2 x 350

Table 5-20 Cable ratings (400 V)

Model	Cable size (IEC) mm ²						Cable size (UL) AWG or Kcmil			
	Input			Output			Input		Output	
	Nominal	Max	Install method	Nominal	Max	Install method	Nominal	Max	Nominal	Max
07400660	35	70	B2	35	70	B2	1	1/0	1	1/0
07400770	50			50			2		2	
07401000	70			70			1/0		1/0	
08401340	2 x 50	2 x 70	B2	2 x 50	2 x 70	B2	2 x 1	2 x 1/0	2 x 1	2 x 1/0
08401570	2 x 70			2 x 70			2 x 1/0		2 x 1/0	
09402000	2 x 70	2 x 185	B1	2 x 95	2 x 150	B2	2 x 3/0	2 x 500	2 x 2/0	2 x 350
09402240	2 x 95	2 x 185		2 x 120	2 x 150		2 x 4/0	2 x 500	2 x 4/0	2 x 350
10402700	2 x 120	2 x 185	C	2 x 120	2 x 150	C	2 x 300	2 x 500	2 x 250	2 x 350
10403200	2 x 150	2 x 185		2 x 150	2 x 150		2 x 350	2 x 500	2 x 300	2 x 350

Table 5-21 Cable ratings (575 V)

Model	Cable size (IEC) mm ²						Cable size (UL) AWG or Kcmil			
	Input			Output			Input		Output	
	Nominal	Max	Install method	Nominal	Max	Install method	Nominal	Max	Nominal	Max
07500440	16	25	B2	16	25	B2	4	3	4	3
07500550	25			25			3		3	
08500630	35	50	B2	35	50	B2	1	1	1	1
08500860	50			50						
09501040	2 x 70	2 x 185	B2	2 x 35	2 x 150	B2	2 x 1	2 x 500	2 x 3	2 x 350
09501310	2 x 70	2 x 185		2 x 50	2 x 150		2 x 1	2 x 500	2 x 1	2 x 350
10501520	2 x 70	2 x 185	B2	2 x 70	2 x 150	B2	2 x 2/0	2 x 500	2 x 2/0	2 x 350
10501900	2 x 95	2 x 185		2 x 70	2 x 150		2 x 2/0	2 x 500	2 x 2/0	2 x 350

Table 5-22 Cable ratings (690 V)

Model	Cable size (IEC) mm ²						Cable size (UL) AWG or Kcmil			
	Input			Output			Input		Output	
	Nominal	Max	Install method	Nominal	Max	Install method	Nominal	Max	Nominal	Max
07600190	10	25	B2	10	25	B2	8	3	8	3
07600240							6		6	
07600290							6		6	
07600380							4		4	
07600440							4		4	
07600540							3		3	
08600630	50	70	B2	50	70	B2	2	1/0	2	1/0
08600860	70			70			1/0		1/0	
09601040	2 x 50	2 x 185	B2	2 x 35	2 x 150	B2	2 x 1	2 x 500	2 x 3	2 x 350
09601310	2 x 70	2 x 185		2 x 50	2 x 150		2 x 1/0	2 x 500	2 x 1	2 x 350
10601500	2 x 70	2 x 185	B2	2 x 70	2 x 150	B2	2 x 2/0	2 x 500	2 x 1/0	2 x 350
10601780	2 x 95	2 x 185		2 x 70	2 x 150		2 x 3/0	2 x 500	2 x 2/0	2 x 350

5.1.21 Maximum motor cable lengths

Since capacitance in the motor cable causes loading on the output of the drive, ensure the cable length does not exceed the values given in Table 5-23.

Use 105 °C (221 °F) (UL 60/75 °C temp rise) PVC-insulated cable with copper conductors having a suitable voltage rating, for the following power connections:

- AC supply to external EMC filter (when used)
- AC supply (or external EMC filter) to drive
- Drive to motor
- Drive to braking resistor

Table 5-23 Maximum motor cable lengths

Model	Maximum permissible motor cable length for each of the following switching frequencies						
	2 kHz*	3 kHz	4 kHz	6 kHz	8 kHz	12 kHz	16 kHz
All size 7 to 10 models	250 m (820 ft)		187 m (614 ft)	125 m (410 ft)	93 m (305 ft)	62 m (203 ft)	46 m (151 ft)

* For the *Unidrive* M200 to M400, the cables lengths at 0.667 and 1kHz switching frequency are the same as cable lengths at 2 kHz.

- Cable lengths in excess of the specified values may be used only when special techniques are adopted; refer to the supplier of the drive.
- The default switching frequency is 3 kHz for Open-loop and RFC-A and 6 kHz for RFC-S mode. The maximum cable length is reduced from that shown in Table 5-23 if high capacitance or reduced diameter motor cables are used, refer to section 4.8.2 *High-capacitance / reduced diameter cables* on page 68.

5.1.22 Braking resistor values

Table 5-24 Minimum resistance values and peak power rating for the braking resistor at 40 °C (104 °F)

Model	Minimum resistance* Ω	Instantaneous power rating kW	Continuous power rating kW
200 V			
07200610	4.5	37.6	15
07200750	4.5	37.6	18.5
07200830	4.5	37.6	22
08201160	2.3	73.5	30
08201320	2.3	73.5	37
09201760 (9A)	2	84.5	45
09202190 (9A)	2	84.5	45
09201760 (9E)	1.4	120.8	45
09202190 (9E)	1.4	120.8	55
10202830	1.7	99.5	75
10203000	1.7	99.5	90
400 V			
07400660	7.5	90.2	30
07400770	7.5	90.2	37
07401000	7.5	90.2	45
08401340	6.3	107.4	55
08401570	6.3	107.4	75
09402000 (9A)	3.6	187.8	90

Model	Minimum resistance*	Instantaneous power rating	Continuous power rating
	Ω	kW	kW
09402240 (9A)	3.6	187.8	110
09402000 (9E)	2.6	260	90
09402240 (9E)	2.6	260	110
10402700	3.1	218.1	132
10403200	3.1	218.1	160
575 V			
07500440	11	87.4	30
07500550	11	87.4	37
08500630	5.5	174.8	45
08500860	5.5	174.8	55
09501040 (9A)	5.1	188.5	75
09501310 (9A)	5.1	188.5	90
09501040 (9E)	3.3	291.3	75
09501310 (9E)	3.3	291.3	90
10501520	3.3	291.3	110
10501900	3.3	291.3	132
690 V			
07600190	13	107.3	15
07600240	13	107.3	18.5
07600290	13	107.3	22
07600380	13	107.3	30
07600440	13	107.3	37
07600540	13	107.3	45
08600630	5.5	253.5	55
08600860	5.5	253.5	75
09601040 (9A)	6.5	214.5	90
09601310 (9A)	6.5	214.5	110
09601040 (9E)	4.2	331.9	90
09601310 (9E)	4.2	331.9	110
10601500	4.2	331.9	132
10601780	3.8	366.8	160

*Resistor tolerance: $\pm 10\%$. The minimum resistance specified are for stand-alone drive systems only. If the drive is to be used as part of a common DC bus system different values may be required. Contact the supplier of the drive for more information.

5.1.23 Terminal size and torque settings

Table 5-25 Drive control terminal data

Model	Connection type	Torque setting
M200 to M400	Screw terminals	0.2 N m (0.15 lb ft)
M600 to M702	Plug-in terminal block	0.5 N m (0.4 lb ft)

Table 5-26 Drive relay terminal data

Model	Connection type	Torque setting
M200 to M400	Screw terminals	0.5 N m (0.4 lb ft)
M600 to M702	Plug-in terminal block	

Table 5-27 Terminal block maximum cable sizes

Model	Size	Terminal block description	Maximum cable size
All	All	Control connector	1.5 mm ² (16 AWG)
M300 to M400	7 to 9	2 way relay connector	2.5 mm ² (14 AWG)
		STO connector	
M600 to M702	All	2 way low voltage power 24V supply connector	1.5 mm ² (16 AWG)

Table 5-28 Maximum crimp/lug sizes for frame size 8 to 10

Terminals	Maximum standard crimp (mm ²)	Maximum standard US lug (kcmil)
AC supply connections	2 x 185	2 x 500
AC supply ground	2 x 120	1 x 350
Motor connections	2 x 150	2 x 350
Drive output ground	2 x 150	1 x 350
Brake connection	2 x 150	2 x 350

Table 5-29 Drive power terminal data

Model size	AC and motor terminals		DC and braking		Ground terminal	
	Recommended	Maximum	Recommended	Maximum	Recommended	Maximum
7	M8 Nut (13 mm AF)		M8 Nut (13 mm AF)		M8 Nut (13 mm AF)	
	12 N m (8.85 lb ft)	14 N m (10 lb ft)	12 N m (8.85 lb ft)	14 N m (10 lb ft)	12 N m (8.85 lb ft)	14 N m (10 lb ft)
8 to 10	M10 Nut (17 mm AF)		M10 Nut (17 mm AF)		M10 Nut (17 mm AF)	
	15 N m (11.1 lb ft)	20 N m (14.8 lb ft)	15 N m (11.1 lb ft)	20 N m (14.8 lb ft)	15 N m (11.1 lb ft)	20 N m (14.8 lb ft)

5.1.24 Electromagnetic compatibility (EMC)

This is a summary of the EMC performance of the drive. For full details, refer to the *EMC Data Sheet* which can be obtained from the supplier of the drive.

Table 5-30 Immunity compliance

Standard	Type of immunity	Test specification	Application	Level
IEC61000-4-2 EN61000-4-2	Electrostatic discharge	6 kV contact discharge 8 kV air discharge	Module enclosure	Level 3 (industrial)
IEC61000-4-3 EN61000-4-3	Radio frequency radiated field	10 V/m prior to modulation 80 - 1000 MHz 80 % AM (1 kHz) modulation	Module enclosure	Level 3 (industrial)
IEC61000-4-4 EN61000-4-4	Fast transient burst	5/50 ns 2 kV transient at 5 kHz repetition frequency via coupling clamp	Control lines	Level 4 (industrial harsh)
		5/50 ns 2 kV transient at 5 kHz repetition frequency by direct injection	Power lines	Level 3 (industrial)
IEC61000-4-5 EN61000-4-5	Surges	Common mode 4 kV 1.2/50 μ s waveshape	AC supply lines: line to ground	Level 4
		Differential mode 2 kV 1.2/50 μ s waveshape	AC supply lines: line to line	Level 3
		Lines to ground	Signal ports to ground ¹	Level 2
IEC61000-4-6 EN61000-4-6	Conducted radio frequency	10V prior to modulation 0.15 - 80 MHz 80 % AM (1 kHz) modulation	Control and power lines	Level 3 (industrial)
IEC61000-4-11 EN61000-4-11	Voltage dips and interruptions	-30 % 10 ms +60 % 100 ms -60 % 1 s <-95 % 5 s	AC power ports	
IEC61000-6-1 EN61000-6-1:2007	Generic immunity standard for the residential, commercial and light - industrial environment			Complies
IEC61000-6-2 EN61000-6-2:2005	Generic immunity standard for the industrial environment			Complies
IEC61800-3 EN61800-3:2004	Product standard for adjustable speed power drive systems (immunity requirements)		Meets immunity requirements for first and second environments	

¹ See section 4.11.8 *Variations in the EMC wiring* on page 89 for possible requirements regarding grounding and external surge protection of control ports.

Emission

The drive contains an internal filter for basic emission control. An additional optional external filter provides further reduction of emission. The requirements of the following standards are met, depending on the motor cable length and switching frequency.

Table 5-31 Size 7 emission compliance (200 V drives)

Motor cable length (m)	Switching Frequency (kHz)						
	2	3	4	6	8	12	16
Using internal filter:							
0 – 100	C4	C4	C4	C4	C4	C4	C4
Using external filter:							
0 – 20	C2	C2	C2	C2	C2	C2	C2
20 – 100	C2	C2	C3	C3	C3	C3	C3

Table 5-32 Size 7 emission compliance (400 V drives)

Motor cable length (m)	Switching Frequency (kHz)						
	2	3	4	6	8	12	16
Using internal filter:							
0 – 100	C4	C4	C4	C4	C4	C4	C4
Using external filter:							
0 – 20	C2	C2	C2	C2	C2	C2	C2
20 – 100	C2	C2	C3	C3	C3	C3	C3

Table 5-33 Size 7 emission compliance (575 and 690 V drives)

Motor cable length (m)	Switching Frequency (kHz)						
	2	3	4	6	8	12	16
Using internal filter:							
0 – 100	C4	C4	C4	C4	C4	C4	C4
Using external filter:							
0 – 20	C2	C2	C2	C2	C2	C2	C2
20 – 100	C2	C2	C3	C3	C3	C3	C3

Table 5-34 Size 8 emission compliance (200 V drives)

Motor cable length (m)	Switching Frequency (kHz)						
	2	3	4	6	8	12	16
Using internal filter:							
0 – 10	C3	C3	C3	C3	C3	C3	C3
Using external filter:							
0 – 20	C2	C2	C2	C2	C2	C2	C2
20 – 100	C2	C2	C3	C3	C3	C3	C3

Table 5-35 Size 8 emission compliance (400 V drives)

Motor cable length (m)	Switching Frequency (kHz)						
	2	3	4	6	8	12	16
Using internal filter:							
0 – 10	C3	C3	C3	C3	C3	C3	C3
Using external filter:							
0 – 20	C2	C2	C2	C2	C2	C2	C2
20 – 100	C2	C2	C3	C3	C3	C3	C3

Table 5-36 Size 8 emission compliance (575 V and 690 V drives)

Motor cable length (m)	Switching Frequency (kHz)						
	2	3	4	6	8	12	16
Using internal filter:							
0 – 100	C4	C4	C4	C4	C4	C4	C4
Using external filter:							
0 – 20	C2	C2	C2	C2	C2	C2	C2
20 – 100	C2	C2	C3	C3	C3	C3	C3

Table 5-37 Size 9 and 10 emission compliance (200 V drives)

Motor cable length (m)	Switching Frequency (kHz)						
	2	3	4	6	8	12	16
Using internal filter:							
0 – 100	C3	C3	C3	C3	C3	C3	C3
Using external filter:							
0 – 20	C2	C2	C2	C2	C2	C2	C2
20 – 100	C2	C2	C3	C3	C3	C3	C3

Table 5-38 Size 9 and 10 emission compliance (400 V drives)

Motor cable length (m)	Switching Frequency (kHz)						
	2	3	4	6	8	12	16
Using internal filter:							
0 – 100	C3	C3	C3	C3	C3	C3	C3
Using external filter:							
0 – 20	C2	C2	C2	C2	C2	C2	C2
20 – 100	C2	C2	C3	C3	C3	C3	C3

Table 5-39 Size 9 and 10 emission compliance (575 V and 690 V drives)

Motor cable length (m)	Switching Frequency (kHz)						
	2	3	4	6	8	12	16
Using internal filter:							
0 - 50	C3	C3	C3	C3	C3	C3	C3
Using external filter:							
0 – 20	C2	C2	C2	C2	C2	C2	C2
20 – 100	C2	C2	C3	C3	C3	C3	C3

Key (shown in decreasing order of permitted emission level):

- E2R EN 61800-3 second environment, restricted distribution (Additional measures may be required to prevent interference)
- E2U EN 61800-3 second environment, unrestricted distribution
- I Industrial generic standard EN 61000-6-4
EN 61800-3 first environment restricted distribution (The following caution is required by EN 61800-3)



This is a product of the restricted distribution class according to IEC 61800-3. In a residential environment this product may cause radio interference in which case the user may be required to take adequate measures.

- R Residential generic standard EN 61000-6-3
EN 61800-3 first environment unrestricted distribution

EN 61800-3 defines the following:

- The first environment is one that includes residential premises. It also includes establishments directly connected without intermediate transformers to a low-voltage power supply network which supplies buildings used for residential purposes.
- The second environment is one that includes all establishments other than those directly connected to a low-voltage power supply network which supplies buildings used for residential purposes.
- Restricted distribution is defined as a mode of sales distribution in which the manufacturer restricts the supply of equipment to suppliers, customers or users who separately or jointly have technical competence in the EMC requirements of the application of drives.

EN 61800-3:2004+A1:2012

The 2004 revision of the standard uses different terminology to align the requirements of the standard better with the EC EMC Directive.

Power drive systems are categorized C1 to C4:

Category	Definition	Corresponding code used previously
C1	Intended for use in the first or second environments	R
C2	Not a plug-in or movable device, and intended for use in the first environment only when installed by a professional, or in the second environment	I
C3	Intended for use in the second environment, not the first environment	E2U
C4	Intended for use in the second environment in a system rated at over 400 A or in a complex system	E2R

Note that category 4 is more restrictive than E2R, since the rated current of the PDS must exceed 400 A or the supply voltage exceed 1000 V, for the complete PDS.

5.2 Optional external EMC filters

Table 5-40 EMC filter cross reference

Model	CT part number
200 V	
07200610 to 07200830	4200-1132
08201160 to 08201320	4200-1972
09201760 to 09202190 (9A)	4200-3021
09201760 to 09202190 (9E)	4200-4460
10202830 to 10203000	4200-4460
400 V	
07400660 to 07401000	4200-1132
08401340 to 08401570	4200-1972
09402000 to 09402240 (9A)	4200-3021
09402000 to 09402240 (9E)	4200-4460
10402700 to 10403200	4200-4460
575 V	
07500440 to 07500550	4200-0672
08500630 to 08500860	4200-1662
09501040 to 09501310 (9A)	4200-1660
09501040 to 09501310 (9E)	4200-2210
10501520 to 10501900	4200-2210
690 V	
07600190 to 07600540	4200-0672
08600630 to 08600860	4200-1662
09601040 to 09601310 (9A)	4200-1660
09601040 to 09601310 (9E)	4200-2210
10601500 to 10601780	4200-2210

5.2.1 EMC filter ratings

Table 5-41 Optional external EMC filter details

CT part number	Maximum continuous current		Voltage rating		IP rating	Power dissipation at rated current		Ground leakage		Discharge resistors
	@ 40 °C (104 °F)	@ 50 °C (122 °F)	IEC	UL		@ 40 °C (104 °F)	@ 50 °C (122 °F)	Balanced supply phase-to-phase and phase-to-ground	Worst case	
	A	A	V	V		W	W	mA	mA	
4200-1132	117	102.7*	528	480	20	50	43.7	11.7	188	1.68
4200-0672	67	58.8*	759	600		25	21.9	24.5	395	2.72
4200-1972	197	172.8*	528	480		42	36.7	18.7	210	1.68
4200-1662	114	100*	759	600		39	34.1	24.3	364	2.72
4200-3021	302	277	528	480	00	34	29.7	30	202	1.68
4200-1660	166	152	759	600		13	11.4	21	332	2.72
4200-4460	446	409	528	480		37	32.4	30	283	1.68
4200-2210	221	203	759	600		16	14.0	21	434	2.72

* At 55 °C (131 °F).

5.2.2 Overall EMC filter dimensions

Table 5-42 Optional external EMC filter dimensions

Part Number	Dimensions (mm)						Weight	
	H		W		D			
	mm	inch	mm	inch	mm	inch	kg	lb
4200-1132	270	10.63	90	3.54	150	5.90	6	13.2
4200-0672	270	10.63	90	3.54	150	5.90	6.2	13.7
4200-1972	300	11.81	120	4.72	170	6.69	9.6	21.2
4200-1662	300	11.81	120	4.72	170	6.69	9.4	20.7
4200-3021	339	13.3	230	9.06	120	4.72	11	24.3
4200-1660	360	14.2	245	9.6	105	4.13	5.2	11.5
4200-4460	105	4.13	360	14.2	245	9.6	12	26.5
4200-2210	105	4.13	360	14.2	245	9.6	10.3	22.7

5.2.3 EMC filter torque settings

Table 5-43 Optional external EMC Filter terminal data

CT part number	Power connections			Ground connections	
	Bar hole diameter	Max cable size	Max torque	Ground stud size	Max torque
4200-1132	N/A	50 mm ² (1/0 AWG)	8.0 N m (6.0lb ft)	M10	18 N m (13.3 lb ft)
4200-0672					
4200-1972		95 mm ² (3/0 AWG)	20 N m (14.8 lb ft)		
4200-1662					
4200-3021	10.8 mm	N/A	30 N m (22.1 lb ft)		
4200-1660					
4200-4460					
4200-2210					

6 UL listing information

6.1 UL file reference

All drives covered by this manual are UL Listed to both Canadian and US requirements. The UL file reference is: NMMS/7.E171230.

Products that incorporate the Safe Torque Off (STO) function are Certified for Functional Safety. The UL file reference is: FSPC.E171230.

6.2 Option modules, kits and accessories

Option Modules, Control Pods, Installation Kits and other accessories for use with these drives are UL Listed.

6.3 Enclosure ratings

Open Type

With the exception of free-standing cubicle drives, all models are Open Type as supplied. The drive housing is not rated as a fire enclosure. A separate fire enclosure must be provided.

Type 1

When fitted with a conduit box the drives meet the requirements for UL Type 1. Type 1 enclosures are intended for indoor use, primarily to provide a degree of protection against limited amounts of falling dirt.

Plenum rating with conduit box

When fitted with a conduit box, the drives comply with the requirements in the Standard for Fire Test for Heat and Visible Smoke Release for Discrete Products and Their Accessories Installed in Air-Handling Spaces, UL 2043.

Through-hole mounting

The drives meet the requirements for UL Type 12 when installed inside a Type 12 enclosure with the heatsink through-hole mounted using the sealing kit and the high-IP insert (where provided).

When through-hole mounted, the drives are suitable for use in surrounding air temperatures up to 40 °C.

When the drive is through-panel mounted, the main terminal cover(s) must be removed in order to provide access to the mounting holes. Once the drive has been mounted, the terminal cover(s) can be replaced.

The tightening torque of the securement brackets shall be advised as being 3 N m (26.6 lb.in).

Remote Keypads

Remote keypads are UL Type 12 when installed with the sealing washer and fixing kit provided.

6.4 Mounting

Drives may be surface, through-panel or tile mounted using the appropriate brackets. Drives may be mounted singly or side by side with suitable space between them (bookcase mounting).

6.5 Environment

Drives must be installed in a Pollution Degree 2 environment or better (dry, non-conductive pollution only).

The drives have been evaluated for use at ambient temperatures up to 40 °C. The drives have additionally been evaluated for 50 °C and 55 °C ambient air temperatures with a derated output.

6.6 Electrical Installation

Overvoltage category

Drives have been evaluated for OVC III.

Supply

The drives are suitable for use on a circuit capable of delivering not more than 100,000 RMS symmetrical amperes, 600 Vac Maximum.

Terminal Torque

Terminals must be tightened to the rated torque as specified in the Installation Instructions.

Wiring Terminals

Drives must be installed using cables rated for 75 °C operation, copper wire only.

Where possible, UL Listed closed-loop connectors sized according to the field wiring shall be used for all field power wiring connections.

Ground connection instructions

UL Listed closed-loop connectors sized according to the field wiring shall be used for grounding connections.

Branch circuit protection

The fuses and circuit breakers required for branch circuit protection are specified in the Installation Instructions.

Opening of branch circuit

Opening of the branch-circuit protective device may be an indication that a fault has been interrupted. To reduce the risk of fire or electric shock, the equipment should be examined and replaced if damaged. If burnout of the current element of an overload relay occurs, the complete overload relay must be replaced.

Integral solid state short circuit protection does not provide branch circuit protection. Branch circuit protection must be provided in accordance with the National Electrical Code (NEC), The Canadian Electrical Code, and any additional local codes.

Dynamic braking

M100, M101, M200, M201, M300 or M400, frame sizes 1 to 4 have been evaluated for dynamic braking applications. Other drive models have not been evaluated for dynamic braking.

6.7 Motor overload protection and thermal memory retention

The devices incorporate solid state overload protection for the motor load. The protection levels are expressed as a percentage of full-load current. Refer to the Control User Guide for further information.

In order for the motor protection to work properly, the motor rated current must be entered into Pr **06** or Pr **05.007**.

The protection level may be adjusted below 150 % if required. Refer to the Control User Guide for further information.

All models are provided with thermal memory retention.

6.8 External Class 2 supply

The external power supply used to power the 24 V control circuit shall be marked: "UL Class 2". The power supply voltage shall not exceed 24 Vdc.

6.9 Requirement for Transient Surge Suppression

This requirement only applies to Frame Size 7 drives with rated input voltage = 575 V.

TRANSIENT SURGE SUPPRESSION SHALL BE INSTALLED ON THE LINE SIDE OF THIS EQUIPMENT AND SHALL BE RATED 575 Vac (PHASE TO GROUND), 575 Vac (PHASE TO PHASE), SUITABLE FOR OVERVOLTAGE CATEGORY III, AND SHALL PROVIDE PROTECTION FOR A RATED IMPULSE VOLTAGE TO WITHSTAND VOLTAGE PEAK OF 6 kV AND A CLAMPING VOLTAGE OF MAXIMUM 2400 V.

6.10 Modular Drive Systems

Drives with DC+ and DC- supply connections, rated 230 V or 480 V have been investigated for use in Modular Drive Systems as inverters when supplied by the converter sections from the Unidrive-M range. In these applications the inverters are required to be additionally protected by supplemental fuses.

Alternatively, the inverters may be supplied by converter models: Mentor MP25A, 45A, 75A, 105A, 155A or 210A.

Contact the supplier of the drive for more information.



0478-0234-10