

> 技术参数 Technical Parameters

REB05系列大规格制动器各配置尺寸

Dimensions for REB05 Large-sized Brakes

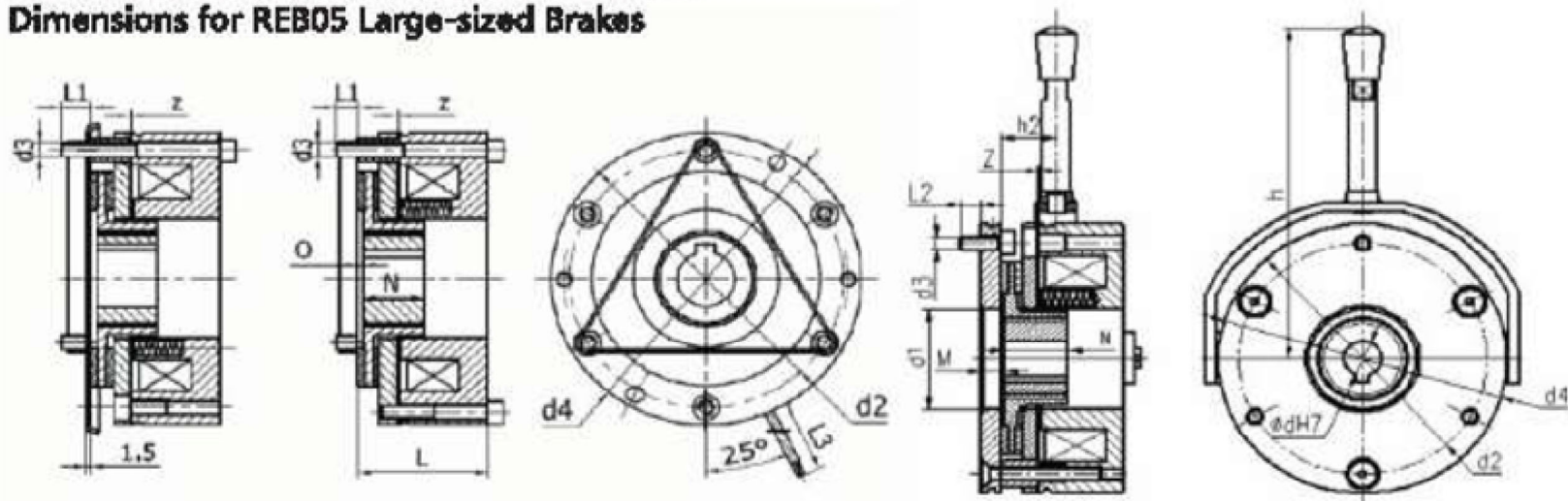

| 机座号 | T | Tmax | d | d1 | d2 | d3 | d4 | M | N | O | L | L1 | L2 | h | h2 | z | L3 |
|-----|----|------|----|----|-----|------|-----|------|----|------|------|------|----|-----|------|-----|------|
| 06 | 4 | 6 | 11 | 31 | 72 | 3×M4 | 84 | 7.5 | 18 | 1 | 35.3 | 9.7 | 6 | 102 | 15.8 | 0.2 | 400 |
| 08 | 8 | 12 | 15 | 42 | 90 | 3×M5 | 102 | 8.5 | 20 | 1.5 | 42.8 | 12.2 | 9 | 114 | 16.3 | 0.2 | 400 |
| 10 | 16 | 23 | 15 | 44 | 112 | 3×M6 | 130 | 10 | 20 | 2 | 48.4 | 11.2 | 12 | 129 | 27.4 | 0.2 | 400 |
| 12 | 32 | 46 | 20 | 52 | 132 | 3×M6 | 150 | 10 | 25 | 2 | 54.4 | 11 | 12 | 162 | 30 | 0.3 | 400 |
| 14 | 60 | 95 | 25 | 60 | 145 | 3×M8 | 165 | 13 | 30 | 2 | 66.3 | 14 | 14 | 201 | 33 | 0.3 | 1000 |
| 16 | 80 | 125 | 30 | 70 | 170 | 3×M8 | 190 | 13.3 | 30 | 2.25 | 72.5 | 12.5 | 14 | 250 | 37.4 | 0.3 | 1000 |

注：

1. 单位为mm
2. T为额定扭矩 (N.m)
3. 表中L3为导线长度，特殊要求可以定制。

Notice:

1. Unit:mm
2. T represents rated torque(N.m)
3. L3 listed in the Table represents the length of the conductor, which could be ordered.