

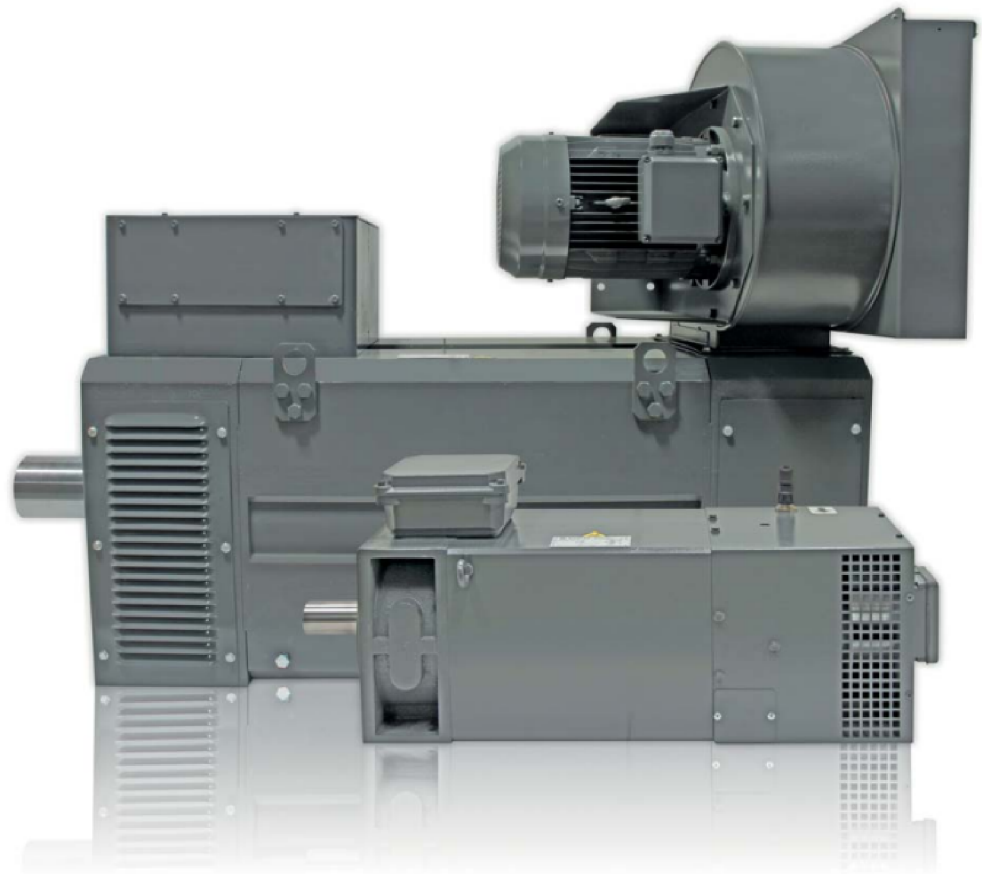

OPERATION AND MAINTENANCE MANUAL

MAC Q MOTORS





CONTENTS

1. LEGAL NOTES AND SAFETY INSTRUCTIONS	5
1.1 Justification	5
1.2 Target readership and purpose	5
1.3 Hazards and warning signs	6
1.4 Intended use	7
1.5 Skilled personnel	7
1.6 Disclaimer	8
1.7 Scope of the documentation and external references	8
2. DECLARATIONS OF CONFORMITY	9
3. PRODUCT DESCRIPTION	12
3.1 General information	12
3.2 Reference standards	13
3.3 Definitions	14
3.3.1 Duty	14
3.3.2 Types of construction	15
3.3.3 Degree of protection IP	16
3.3.4 Cooling Methods	17
3.3.5 Vibration grade	18
3.3.6 Insulation class	19
3.3.7 Heating limits	19
3.4 Nameplate	20
3.5 General specifications	21
3.5.1 Motor code	21
3.5.2 Ambient conditions	21
3.5.3 Duty	21
3.6 Mechanical specifications	23
3.6.1 Types of construction	23
3.6.2 Degree of protection IP	24
3.6.3 Cooling Method	25
3.6.4 Balancing and vibration grade	25
3.6.5 Bearings	26
3.7 Electrical specifications	28
3.7.1 Windings and insulation	28



3.7.2	Connections	28
3.7.3	Power-supply conditions	29
3.7.4	Standard thermal protection	30
3.7.5	Optional thermal sensors	30
3.7.6	Anti-condensation heaters	31
3.7.7	Fan and pressure gauge	32
3.8	Accessories	33
3.8.1	Feedback sensors	33
3.8.2	Parking brake	34
3.8.3	Noise level	35
4.	SHIPMENT, RECEPTION, TRANSPORT AND STORAGE	36
4.1	Shipment	36
4.2	Reception	36
4.3	Transport	37
4.4	Storage	38
5.	INSTALLATION AND START-UP	39
5.1	Motor installation	39
5.1.1	Site	39
5.1.2	Mounting	40
5.1.3	Machine coupling	41
5.2	Electrical connections	43
5.2.1	Connector strips and terminals	44
5.2.2	Connection diagrams	45
5.2.3	Power cables	46
5.2.4	Connections for the fan, thermal sensors and accessories	48
5.2.5	Final checks	48
5.3	Start-up	49
5.3.1	Preliminary checks	49
5.3.2	Start-up	50
6.	MAINTENANCE	51
6.1	Safety instructions	51
6.2	Maintenance operations and frequency	51
6.2.1	Basic inspection	52
6.2.2	Cleaning of the fan and air filter	52



6.2.3	Re-greasing of the bearings	53
6.2.4	Replacement of bearings	54
6.3	Replacing the encoder	56
6.3.1	Solid shaft encoder	56
6.3.2	Hollow blind shaft encoder	56
6.4	Replacing the brake and/or lining	57
6.5	Original spares	58
6.6	Operating faults	60
6.6.1	Electrical faults	60
6.6.2	Mechanical faults	62
6.7	Technical support and service	63



1. LEGAL NOTES AND SAFETY INSTRUCTIONS

1.1 Justification

VASCAT motors contain low-voltage parts and rotating elements that make them hazardous; they also contain hot surfaces. Users must take notice of all the hazard warning signs described in this manual (see Section 1.3).

All tasks related to the transport, connection, commissioning and maintenance must be performed by responsible, skilled personnel (in accordance with the EN 50110-1 (VDE 0105-100) and IEC 60364 standards). Inappropriate procedures may cause serious personal injury and material damages.

VASCAT motors may only be used for the purposes specified in Section 1.4.

Furthermore, the site conditions must meet all the requirements given on the motor nameplate and in this document.

1.2 Target readership and purpose

The purpose of the operation manual is to provide all the information required for the appropriate mounting, commissioning and maintenance of the MAC QI/QE/QX motors and avoid hazards that may cause serious injury. The manual is targeted for any person or individual who handles or is responsible for operation of the motors dealt with in the manual.

All the individuals working with MAC QI/QE/QX three-phase motors must have this manual at their disposal and they must follow the relevant instructions and indications.

The operation and maintenance instructions must be read carefully before operating the machine. This will guarantee proper operation free from hazards and complications and will extend the service life of the machine.

These service instructions provide a description of the machine and information for its proper handling and operation from delivery to the end of its service life.

This manual must always be complete and perfectly legible.



1.3 Hazards and warning signs

The manual contains the information required for personnel safety and the prevention of material damages. All information related to personnel safety is highlighted in general with a warning triangle; however, the hints (to avoid only material damages) are not. Depending on the hazard level, the signs indicate hazards from major to minor as follows:



DANGER

If no appropriate measures are taken, the result will be death or serious injury.



WARNING

If no preventive measures are adopted, the result may be death or serious injury.



CAUTION

If no appropriate measures are taken, the result may be serious injury.

PRECAUTION

If no appropriate measures are taken, the result may be material damages.

NB

The result may be an unwanted condition or situation if the corresponding safety instruction is not observed.

If several hazard levels are present at the same time, the most stringent instruction for each case will apply. If a safety instruction with a warning triangle warns of personal injury, the same instruction may also contain a warning of possible material damages.

Signs indicating the type of danger Warning or Caution in the manual that may be used together with the pictograms above are as follows:



VOLTAGE

Indicates the presence of voltage on connection terminals or live parts.



HOT SURFACE

Indicates the possibility of the contact surface having a very high temperature with the consequent risk of burns.



MOVING ROTATING PARTS

Indicates the possibility of injury and trauma caused by contact with shafts and other rotating parts.



1.4 Intended use



WARNING

VASCAT motors have been designed for industry plants. They comply with the requirements of the harmonised standards of the EN 60034 series.

Such pieces of equipment are devices designed to be mounted in machines in accordance with the current Machinery Directive. Commissioning is not allowed until the end product is checked and found to be compliant with said Directive (please see, among others, the EN 60204-1 standard).

VASCAT MAC QI/QE/QX motors must be used only for the applications provided in the catalogues and the related technical documentation.

If third-party products and parts are used, they must be previously approved by VASCAT.

Proper and safe operation of the products requires their proper transportation, storage, installation, mounting, assembly, operation and maintenance.

Allowed ambient conditions must be observed. The use of MAC QI/QE/QX motors in hazardous areas is strictly prohibited unless they have been designed specifically for said circumstance, in which case the indications and warnings given in the related documentation must be observed.

1.5 Skilled personnel



WARNING

VASCAT motors must be installed and operated in accordance with the specifications given in this document. Only skilled personnel in the context of the manual, i. e. individuals who have the required technical know-how and skills for handling, commissioning and starting the motors according to safety standards, shall be allowed to operate the motors.

Skilled personnel refers to those individuals who are capable of recognising the risks related to their field of activity and avoiding the related hazards.



1.6 Disclaimer

The indications given in the manual describe the product features, but no warranty is implied.

VASCAT declines all liability for damages and operating faults caused by the following:

- Failure to follow the operating instructions.
- Damages caused by inappropriate motor handling.
- Changes made to motors without prior authorisation.
- Operating errors.
- Carrying out inappropriate work on and with the motors.

The indications that refer to procedures and the connection details provided in the manual must be considered only as proposals and whether or not they are applicable must be studied for each case in particular. VASCAT does not guarantee their appropriateness in any case.

The data given in this manual is reviewed regularly and subsequent editions are published when corrections are necessary.

1.7 Scope of the documentation and external references

The manual contains all the information required for the correct handling, installation (electrical and mechanical), commissioning and subsequent maintenance of MAC QI/QE/QX series motors, together with the accessories required for proper operation.

It also describes the safety instructions to guarantee that no personal injuries or material damages will be caused during the entire process.

If the motor design includes any special features (considered as non-standard), additional documentation may be necessary. In those cases, the customer must check with VASCAT to make sure that he has all the relevant information.

This document provides no information about the technical data sheets or the specific technical data of the various MAC QI/QE/QX models or their characteristic curve.

To obtain said information, please log on to the VASCAT website at <http://www.vascat.com>.



2. DECLARATIONS OF CONFORMITY

	CE CONFORMITY DECLARATION MAC QI MOTORS
---	--

VASCAT, S.A., CONFORMITY DECLARATION

The company VASCAT S.A., with registered offices in C/ Esquirol s/n – 08570 Torelló –Spain

DECLARES

The motors of the series MAC QI 100 to MAC QI 250 comply with the basic requirements set forth in the following Directives:

- 2006/95/CE – Low Voltage Directive
- 2006/46/CE – Machinery Directive
- 89/336/CEE & 92/31/CEE – Electromagnetic Compatibility Directive
- 93/68/CEE – CE Marking Directive

These motors have been manufactured in compliance with the following standards:

- UNE-EN 60034-1
- UNE-EN 60034-5
- UNE-EN 60034-8
- UNE-EN 60034-9

In consequence to the above-mentioned standards, this declaration will no longer be valid when changes are made without our prior consent.

The specified product shall be installed as a part of a machine only. Commissioning of the product is not allowed until it has not been checked that the end product complies with above mentioned operation standards.

Torelló 24th April 2014

J.L. Garcia Bujía
General Manager



CE CONFORMITY DECLARATION
MAC QX MOTORS

VASCAT, S.A., CONFORMITY DECLARATION

The company VASCAT S.A., with registered offices in C/ Esquirol s/n – 08570 Torelló –Spain

DECLARES

The motors of the series MAC QX 100 to MAC QX 200 comply with the basic requirements set forth in the following Directives:

2006/95/CE – Low Voltage Directive
2006/46/CE – Machinery Directive
89/336/CEE & 92/31/CEE – Electromagnetic Compatibility Directive
93/68/CEE – CE Marking Directive

These motors have been manufactured in compliance with the following standards:

- UNE-EN 60034-1
- UNE-EN 60034-5
- UNE-EN 60034-8
- UNE-EN 60034-9

In consequence to the above-mentioned standards, this declaration will no longer be valid when changes are made without our prior consent.

The specified product shall be installed as a part of a machine only. Commissioning of the product is not allowed until it has not been checked that the end product complies with above mentioned operation standards.

Torelló 24th April 2014

J.L.García Buja
General Manager



CE CONFORMITY DECLARATION
MAC QE MOTORS

VASCAT, S.A., CONFORMITY DECLARATION

The company VASCAT S.A., with registered offices in C/ Esquirol s/n – 08570 Torelló –Spain

DECLARES

The motors of the series MAC QE 100 to MAC QE 250 comply with the basic requirements set forth in the following Directives:

2006/95/CE – Low Voltage Directive
2006/46/CE – Machinery Directive
89/336/CEE & 92/31/CEE – Electromagnetic Compatibility Directive
93/68/CEE – CE Marking Directive

These motors have been manufactured in compliance with the following standards:

- UNE-EN 60034-1
- UNE-EN 60034-5
- UNE-EN 60034-8
- UNE-EN 60034-9

In consequence to the above-mentioned standards, this declaration will no longer be valid when changes are made without our prior consent.

The specified product shall be installed as a part of a machine only. Commissioning of the product is not allowed until it has not been checked that the end product complies with above mentioned operation standards.

Torelló 24th April 2014

J.L.García Bujía
General Manager



3. PRODUCT DESCRIPTION

VASCAT MAC QI/QE/QX motors are asynchronous AC electrical machines with a squirrel-cage rotor, square laminated steel frame and forced cooling. They have been specially designed to operate in high-dynamics applications that require speed variation. They must be powered exclusively by frequency converters.

3.1 General information

The following table shows the standard technical specifications of the MAC-QI/QE/QX series:

Technical specifications	Description
Motor type	<i>Three-phase asynchronous motor with squirrel-cage rotor</i>
Frame sizes (Shaft heights)	<i>MAC-QI series: 100, 132, 160, 200 and 250 mm MAC-QX series: 100, 132, 160 and 200 mm MAC-QE series: 100, 132, 160, 200 and 250 mm</i>
No. of poles	<i>Frames 100, 132 and 160 mm: 4 poles Frames 200 and 250 mm: 6 poles</i>
Protection rating (According to the IEC/EN 60034-5 standard)	<i>MAC-QI series: IP23 MAC-QX series: IP23 MAC-QE series: IP54</i>
Type of cooling (According to the IEC/EN 60034-6 standard)	<i>MAC-QI series: IC06 MAC-QX series: IC06 MAC-QE series: IC416</i>
Power-supply voltage	<i>Up to 500 VAC (other voltages on request)</i>
Insulation class (According to the IEC/EN 60034-1 standard)	<i>Materials Class H - Operating temperature Class F</i>
Mounting type (According to the IEC/EN 60034-7 standard)	<i>IM B3 or B35 (other types of assembly optional)</i>
Thermal protection (According to the IEC/EN 60034-11 standard)	<i>PTC140 probe on stator winding (other sensors optional)</i>
Installation altitude (According to the IEC/EN 60034-1 standard)	<i><1000 m above sea level</i>
Operating temperature (According to the IEC/EN 60034-1 standard)	<i>0 to +40°C</i>
Vibration level (According to the IEC/EN 60034-14 standard)	<i>Class A (Class B optional)</i>
Shaft and flange types (According to the IEC/EN 60072-1 standard)	<i>Solid shaft with keyway and B5 flange (other setups optional)</i>
Bearings	<i>Rigid ball bearings (other types optional)</i>
Paint	<i>Synthetic enamel RAL 7043 colour (other types optional)</i>
Feedback sensors (optional)	<i>Incremental optical TTL or HTL 1024 or 2084 ppr encoder Incremental optical Sin/Cos 1 Vpp 1024 or 2084 ppr encoder (Other types of sensors available on request)</i>
Brake (optional)	<i>Electromagnetic parking brake in case of 24VDC failure (Other types of brake available on request)</i>

Table 1: General specifications of MAC-Q motors

On many occasions, VASCAT, S.A. adapts its motors to the specific requirements of each customer/application. Therefore, the above table must be understood as a general reference only. The exact specifications of each motor can be found on the corresponding technical data sheet and the additional documentation provided to the customer (where applicable).



3.2 Reference standards

The MAC QI/QE/QX motors are designed and manufactured according to the Low Voltage Directive 2006/95/CE and they have been designed for their use in industrial applications as an incomplete machine or as a machine component as provided for in the 2006/46/CE Machinery Directive.

The following table summarises the main reference technical standards that have been taken into account for the design of these motors:

Standard	Description
IEC/EN 60034-1	<i>Rating and performance</i>
IEC/EN 60034-2	<i>Standard methods for determining losses</i>
IEC/EN 60034-5	<i>Degrees of protection</i>
IEC/EN 60034-6	<i>Cooling</i>
IEC/EN 60034-7	<i>Classification of construction types</i>
IEC/EN 60034-8	<i>Terminal markings and direction of rotation</i>
IEC/EN 60034-9	<i>Noise limits</i>
IEC/EN 60034-11	<i>Thermal protection</i>
IEC/EN 60034-14	<i>Mechanical vibration levels</i>
IEC/EN 60034-18	<i>Functional evaluation of insulation systems</i>
TS 60034-25	<i>Guidance for the design and performance of a.c. motors specifically designed for converter supply</i>
IEC/EN 60072-1	<i>Power series and dimensions of rotating electrical machines</i>

Table 2: Reference standards

In accordance with the current Machinery Directive, the commissioning of these motors is prohibited in the European Union until conformity of the installation has been confirmed in which the machine is to be installed (see EN 60204-1). If the electrical machine is to be used outside the European Union, the specific laws of the country in which it is located will apply. Furthermore, safety standards, local installation and industry-specific standards must be applied.



The data given in all the documentation provided by VASCAT includes tolerances in accordance with the IEC/EN 60034-1 standard and they are based on test procedures as provided in the IEC 60034-2 standard. The table shows the tolerances for some of the most relevant parameters:

Power	Efficiency	Power factor	Slip	Maximum torque	Inertia	Noise level
P _n < 150 kW	-15% (1-η)	-1/6 (1-cos φ)	+/-20%	-10%	+/-10%	+3 dB
P _n > 150 kW	-10% (1-η)	-1/6 (1-cos φ)	+/-20%	-10%	+/-10%	+3 dB

Table 3: Tolerances

3.3 Definitions

3.3.1 Duty

Three-phase induction motors are usually designed to deliver their rated power in continuous service with no overheating problems. However, most motors operate under a non-continuous type of service. Some motors are switched on for a few moments only, others work all day, but they only charge up briefly, etc. The EN 60034-1 standard defines 10 main service types and those summarised in the table below apply to MAC QI/QE/QX motors:

Duty	Description	Definition
S1	<i>Continuous duty</i>	<i>Operation under constant load, for a time duration enough to reach thermal balance.</i>
S2	<i>Short-time duty</i>	<i>Operation under constant load, for a time period shorter than required to reach thermal balance, followed by a standby period that is sufficient to cool down to ambient temperature.</i>
S3	<i>Intermittent periodic duty</i>	<i>A series of identical duty cycles consisting of a constant-load period followed by a stillstand period.</i>
S5	<i>Temporary intermittent duty with starting and electric braking</i>	<i>A series of identical duty cycles consisting of a start period, a constant-load period and an electric braking period, followed by a stillstand period.</i>
S6	<i>Continuous operation periodic duty under intermittent load</i>	<i>A series of identical duty cycles consisting of a constant-load period followed by a no-load operation period.</i>
S7	<i>Continuous operation periodic duty under intermittent load with electric braking</i>	<i>A series of identical duty cycles consisting of a start period, a constant-load period, a no-load period and an electric braking period.</i>

Table 4: Duty types



3.3.2 Types of construction

The following are some of the mounting types applicable to the MAC QI/QE/QX motors, labelled in accordance with the IEC/EN 60034/7 standard.











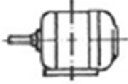

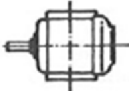

Type of construction	Enclosure	Mounting	Type of construction	Enclosure	Mounting
IM B3 IM1001		<i>Foot mounted, on lower horizontal plane</i>	IM V1 IM3011		<i>Flange mounted, shaft downward (with through holes)</i>
IM B5 IM3001		<i>Flange mounted, horizontally (with through holes)</i>	IM V3 IM3031		<i>Flange mounted, shaft downward (with through holes)</i>
IM B6 IM1051		<i>Foot mounted on vertical plane (shaft to the left)</i>	IM V5 IM1011		<i>Foot mounted on vertical plane (shaft downward)</i>
IM B7 IM1061		<i>Foot mounted on vertical plane (shaft to the right)</i>	IM V6 IM1031		<i>Foot mounted on horizontal plane (shaft downward)</i>
IM B8 IM1071		<i>Foot mounted on horizontal plane (shaft to the right)</i>	IM V18 IM3611		<i>Flange mounted, shaft downward (with threaded holes)</i>
IM B14 IM3601		<i>Flange mounted (with through holes)</i>	IM V19 IM3631		<i>Flange mounted, shaft upward (with threaded holes)</i>
IM B35 IM2001		<i>Flange and foot mounted (with through holes)</i>	IM V15 IM2011		<i>Flange mounted, (with through holes), shaft downward and feet</i>
			IM V36 IM2031		<i>Flange mounted (with through holes), shaft downward and feet</i>

Table 5: Types of construction

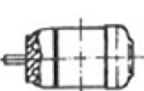

3.3.3 Degree of protection IP

The degree of protection of electrical machines is defined in accordance with IEC/EN 60034-5. Said standard specifies the degree of protection of each machine using an 'IP' code, which comprises two digits:

- First digit: Indicates the degree of protection for contact and solid bodies.
- Second digit: Indicates the degree of protection for water.

The table below shows the meaning of each digit:

First digit	Protected against	Second digit	Protected against
0	No special protection against the ingress of foreign objects.	0	No special protection against the ingress of water.
1	Accidental contact with large surfaces, e. g. the back of a hand. Ingress of foreign objects with a diameter greater than 50mm.	1	Dripping water (vertically falling drops)
2	Contact with fingers. Ingress of foreign objects with a diameter greater than 12mm.	2	Dripping water, when tilted up to 15 degrees from its vertical position.
3	Contact with tools, wires, etc. with a diameter greater than 2,5mm. Ingress of foreign objects with a diameter greater than 2,5mm.	3	Spraying water at any angle up to 60 degrees from its vertical position.
4	Contacts with tools, wires with a diameter greater than 1 mm. Ingress of foreign objects with a diameter greater than 1 mm.	4	Water splashing from any direction.
5	Complete protection against contact. Protection against harmful dust deposits.	5	Water jets from any direction.
6	Complete protection against contact. Complete protection against the ingress of dust.	6	Powerful water jets with increased pressure (sea).
		7	Protection against temporary immersion under the specified pressure and for the time specified.
		8	Continuous immersion.

Table 6: IP code

For example, a machine defined as IP54 indicates complete protection against contact and water spraying from any direction.



3.3.4 Cooling Methods

The cooling methods used in electrical machines are regulated by the IEC/EN 60034-6 standard. In order to identify the cooling method used in each motor, it is also given a code similar to the IP protection rating. There are two types of code: complete code (e.g. IC9A7W7) and short code (e.g. IC97W). Both begin with the initials IC (International Cooling).

The table below shows the most common cooling methods for MAC motors:

SHORT CODE	COMPLETE CODE	EN60034-6	DESCRIPTION
IC00	IC0A0		Free circulation using the surrounding medium by means of free convection
IC01	IC0A1		Self-ventilated with integral fan cooling, Cooling air is blown through the motor by a fan mounted on the shaft
IC06	IC0A6		Separate ventilation with radial fitted fan unit, Cooling air is blown through the motor by a separately excited fan motor. The inlet side may be equipped with an air filter.
IC16	IC1A6		Circulation via pipe or duct, Cooling medium is supplied by external part
IC17	IC1A7		Single pipe ventilated, Cooling air is blown across the motor through the pipe connection with a separate customer provided external blower fan and discharges on the other side to open space.
IC37	IC3A7		Double pipe ventilated, Cooling air is blown across the motor through a pipe connecting by means of a separate customer provided external blower fan and discharges on the other side's pipe connecting.
IC410	IC4A1A0		Totally-enclosed nonventilated, Cooling without using a fan, only by natural ventilation and radiation on the totally enclosed motor surface.
IC411	IC4A1A1		Totally-enclosed fan-cooled, Cooling air is blown over the totally enclosed motor surface by a fan mounted on the shaft.
IC416	IC4A1A6		External surface cooling, Cooling air is blown over the totally enclosed motor surface by a separately excited fan motor.
IC97W	IC9A7W7		Cooling using an independent heat exchanger by means of liquid coolant or remote fluid

Table 7: Cooling methods



3.3.5 Vibration grade

The EN 60034-14 international standard specifies the factory acceptance vibration test procedures and vibration limits for certain electrical machines under specified conditions, when uncoupled from any load or prime mover.

The standard defines two vibration grades: Grade 'A' (machines with no special vibration requirements); and Grade 'B' (machines with special vibration requirements).

The table below shows the limits of maximum vibration magnitude in displacement, velocity and acceleration (RMS) for shaft height (H):

Vibration grade	Shaft height (mm)	56 ≤ H ≤ 132			132 < H ≤ 280			H > 280		
	Mounting	Displac. μm	Vel. mm/s	Accel. m/s ²	Displac. μm	Vel. mm/s	Accel. m/s ²	Displac. μm	Vel. mm/s	Accel. m/s ²
A	<i>Free suspension</i>	25	1.6	2.5	35	2.2	3.5	45	2.8	4.4
	<i>Rigid mounting</i>	21	1.3	2	29	1.8	2.8	37	2.3	3.6
B	<i>Free suspension</i>	11	0.7	1.1	18	1.1	1.7	29	1.8	2.8
	<i>Rigid mounting</i>				14	0.9	1.4	24	1.5	2.4

Table 8: Limits of maximum vibration magnitude

When no grade is specified, machines complying with this standard shall be grade "A".



3.3.6 Insulation class

The insulation thermal class rating of an electrical machine is identified on the motor nameplate by means of a letter in accordance with the IEC/EN 60034-18 international standard.

The table below summarises the maximum allowed temperature in the insulation system of a winding in accordance with its insulation thermal class rating:

Thermal class rating	Thermal class
A	105°C
E	120°C
B	130°C
F	155°C
H	180°C

Table 9: Thermal classes

3.3.7 Heating limits

The IEC60034-1 international standard defines the maximum admissible heating (temperature rise) for the windings as specified in the table below:

Thermal class	Coolant temperature	Heating (per element)	Operating temperature
B (130°C)	< 40°C	< 80°C	< 120°C
F (155°C)	< 40°C	< 105°C	< 145°C
H (180°C)	< 40°C	< 125°C	< 165°C

Table 10: Heating limits

In this regard the rated working conditions of the motor must be such that the operating temperature on the windings is always below the temperature specified by the insulation class of its composing materials. Therefore, the working thermal class of a motor can correspond to the following:

- The same thermal insulation class.** This would be the case of a motor built with **Class F** insulation (155°C) with a maximum working temperature of 140°C, corresponding to a **Class F**.
- A thermal class lower than the insulation class.** This would be the case of a motor built with **Class H** insulation (180°C) with a maximum working temperature of 140°C, corresponding to a **Class F**.



3.4 Nameplate

All MAC QI/QE/QX motors are provided with the following nameplate:

		MOTORES ELECTRICOS 08570 TORELLÓ Barcelona (España) http://www.vascat.es				
<input type="radio"/> MOTOR MAC-Q		<input type="text" value="1"/>	<input type="text" value="2"/>	Polos Pole	<input type="text" value="EN60034"/>	<input type="text" value="18"/>
Nr.	<input type="text" value="3"/>	Año Year	<input type="text" value="4"/>	Ejec. Mounting	<input type="text" value="IM"/>	<input type="text" value="19"/>
PN	<input type="text" value="5"/> kW	MN	<input type="text" value="6"/>	Protec. Protect.	<input type="text" value="IP"/>	<input type="text" value="20"/>
UN	<input type="text" value="7"/> V	FN	<input type="text" value="8"/>	Refrig. Cooling	<input type="text" value="IC"/>	<input type="text" value="21"/>
IN	<input type="text" value="9"/> A	Cos φ	<input type="text" value="10"/>	eff	<input type="text" value="11"/>	%
n_N	<input type="text" value="12"/> rpm	n_{max}	<input type="text" value="13"/>	Servicio Duty	<input type="text" value="S"/>	<input type="text" value="23"/>
<input type="radio"/> Vent. Fan	<input type="text" value="14"/> V	<input type="text" value="15"/> A	50 / 60 Hz	Freno Brake	<input type="text" value="16"/> Nm	<input type="text" value="17"/> V

Figure 1: MAC-Q motor nameplate

The table below describes the included motor nameplate data:

Pos.	Description	Pos.	Description
1	Motor type	2	No. of poles
3	Serial No.	4	Year of manufacture
5	Rated power PN in kW	6	Rated torque MN in Nm
7	Rated voltage UN in V	8	Rated frequency FN in Hz
9	Rated current IN in A	10 / 11	Power factor Cos φ / Efficiency in %
12	Rated speed n_N in rpm	13	Maximum mechanical speed n_{max} in rpm
14 / 15	Voltage (V) and Current (A) of the axial fan(*)	16 / 17	Torque (Nm) and Voltage (V) of the brake (**)
18	EN60034 family of reference standards	19	Mounting type Code IM (EN60034-7)
20	Protection rating IP code (EN60034-5)	21	Cooling method IC code (EN60034-6)
22	Winding working temperature CL code (EN60034-1)	23	Duty S code (EN60034-1)

Table 11

(*) positions 14 / 15 are checked only if there is an axial fan.

(**) Positions 16 / 17 are checked only if there is a parking brake.



3.5 General specifications

3.5.1 Motor code

MAC QI/QE/QX series motors are coded as follows:

MAC	QI		200	M	H61
<i>Motor type</i>	<i>Series</i>		<i>Size</i>	<i>Length</i>	<i>Winding</i>
Asynchronous Motor for frequency Converter	QI	IP23 – IC06 Radial fan	100 132 160	K S M L P X	Defines the rated motor speed
	QX	IP 23 – IC06 Axial fan	200 250		
	QE	IP54 – IC416 Axial fan	Shaft height (mm)		

Table 12: MAC-Q motor codes

3.5.2 Ambient conditions

In their standard version, MAC QI/QE/QX motors are not suitable for working in saline or corrosive atmospheres or for installation outdoors.

3.5.3 Duty

The rated power assigned for continuous service (S1 duty type) assumes an ambient temperature between -20° and +40°C and altitudes of up to 1000 m.

If the working conditions are different from those above, a derating factor (K1) must be applied to the rated torque and power (See table below):

Altitude	Temperature			
	30°C	40°C	50°C	55°C
1000 [m]	1	1	0.92	0.86
2000 [m]	1	0.93	0.85	0.77
3000 [m]	0.93	0.85	0.76	0.69
4000 [m]	0.86	0.78	0.67	0.6

Table 13: Declassing factors

If the motor does not work in continuous service (S1), but rather in an S2 Short-time duty type, a multiplication factor must be applied (K2) to the torque and power specified on the nameplate (S1 Service) to determine the torque available for this service. The K2 factor is determined by the duration of the service according to the graph below.

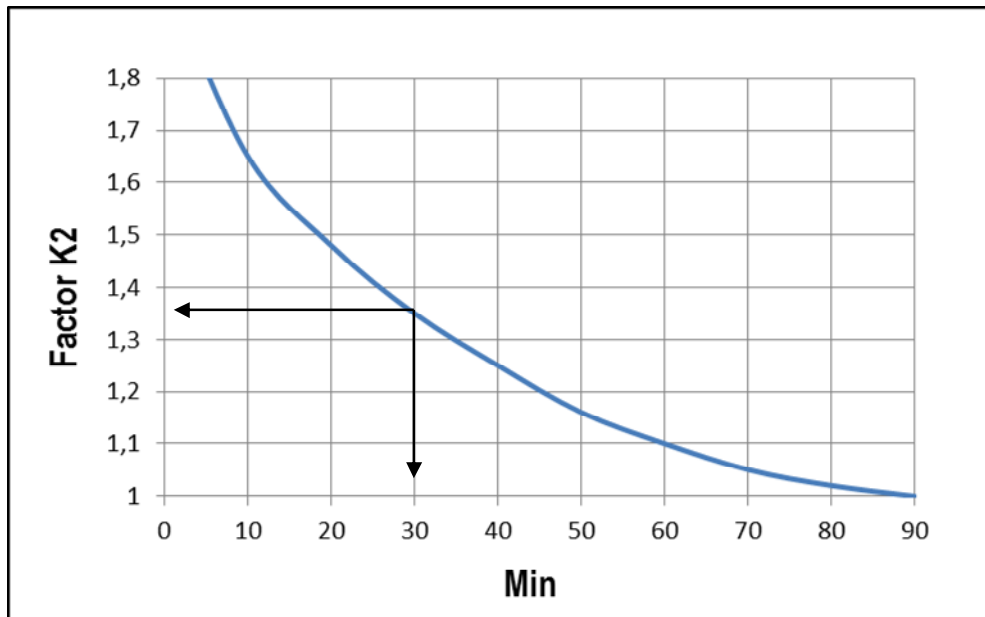

Figure 2: Derating factor for an S2-type service



3.6 Mechanical specifications

3.6.1 Types of construction

Available construction types for MAC QI/QE/QX motors are detailed in the table below:







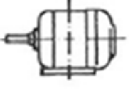

EN 60034-7		FRAME SIZES				
		100	132	160	200	250
	IM B3 IM 1001	OK	OK	OK	OK	OK
	IM V5 IM 1011	OK	OK	OK	C	C
	IM V6 IM 1031	OK	OK	OK	C	C
	IM B5 IM 3001	OK	C	X	X	X
	IM V1 IM 3011	OK	OK	OK	C	C
	IM V3 IM 3031	OK	OK	OK	C	C
	IM B3/B5 IM 2001	OK	OK	OK	OK	OK
	IM V1/V5 IM 2011	OK	OK	OK	C	C
	IM V3/V6 IM 2031	OK	OK	OK	C	C

Table 14: Available construction types for MAC-Q motors

OK: Construction possible

X: Construction not possible

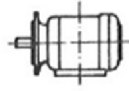
C: Consult



3.6.2 Degree of protection IP

MAC-QI/QE/QX motors are defined with the following IP degrees:

Motor	Standard version	Optional ratings
MAC QI	<i>IP23</i>	<i>IP44</i>
MAC QE	<i>IP54</i>	<i>IP55</i>
MAC QX	<i>IP23</i>	

Table 15: Degree of protection of MAC-Q motors

The motors defined as IP23 must take some precautions if they are installed in environments that are dusty, damp or subject to adverse weather.

The motors defined as IP54 or higher degree of protection can be installed in damp and dusty industrial environments.



3.6.3 Cooling Method

The table below summarises the available cooling methods for the MAC QI/QE/QX motors:

COOLING	EN60034-6	PROTECTION	MAC QE	MAC QX	MAC QI
IC06		IP 23	X	OK	OK
IC16		IP 23	X	X	OK
IC17		IP 23	X	X	OK
IC37		IP 54	X	X	OK
IC416		IP 54/55	OK	X	X
IC06		IP44	X	X	OK

Table 16: Available cooling methods for MAC-Q motors

OK: Construction possible

X: Construction not possible

3.6.4 Balancing and vibration grade

VASCAT motors are defined as A-grade vibration level machines (according to EN 60034-14). B-grade can also be supplied on request.



3.6.5 Bearings

MAC Q motors include different bearings types depending on their frame size (shaft height). The table below summarises the bearings considered standard for each of them:

Motor type	Bearing		max n	n	L10h	C	max P	A	B	max X	max Fr
			rpm	rpm	h	N	N	mm	mm	mm	N (**)
MAC QE/QI/QX 100	D.E.	6308ZZC3	7500	1500	20000	42500	3494	26.5	209	80	1900
	N.D.E.	6207ZZC3	9000	1500	20000	25500	2096	26.5	209	80	3300
MAC QE/QI/QX 132	D.E.	6310ZZC3	6000	1500	20000	62000	5097	36.5	215.5	110	2400
		N310 (*)	5000	1500	20000	130000	13720				6500
	N.D.E.	6208ZZC3	8500	1500	20000	29000	2384	36.5	215.5	110	2800
MAC QE/QI/QX 160	D.E.	6312ZZC3	5000	1500	20000	81900	6733	35.5	503	110	4200
		N312 (*)	4300	1500	20000	151000	15937				9900
	N.D.E.	6310ZZC3	6000	1500	20000	61800	5080	35.5	503	110	14100
MAC QI/QE/QX 200	D.E.	6316ZZC3	3800	1500	20000	122000	10029	40.5	556.5	140	6100
		6316 C3 (*)	4500	1500	20000	122000	10029				6100
		N316 (*)	3200	1500	20000	260000	27440				16600
	N.D.E.	6312ZZC3	5000	1500	20000	114000	9372	40.5	556.5	140	23100
MAC QI/QE/QX 200 X	D.E.	6219ZZC3	3600	1500	20000	108000	8878	40.5	556.5	140	5400
		6219 C3 (***)	4000	1500	20000	108000	8878				5400
		N219 (*)	3100	1500	20000	260000	21374				12900
MAC QI/QE 250	D.E.	6224 C3 (***)	4300	1500	20000	146000	12002	54.5	694	170	7300
		N224 (*)	2400	1500	20000	390000	41161				24900
	N.D.E.	6316 C3 (***)	5500	1500	20000	122000	10029	58.5	691	170	24300

Table 17: Technical specifications of MAC-Q motor bearings

N.D.E. = Rear / Non Drive End

DE = Front / Drive End

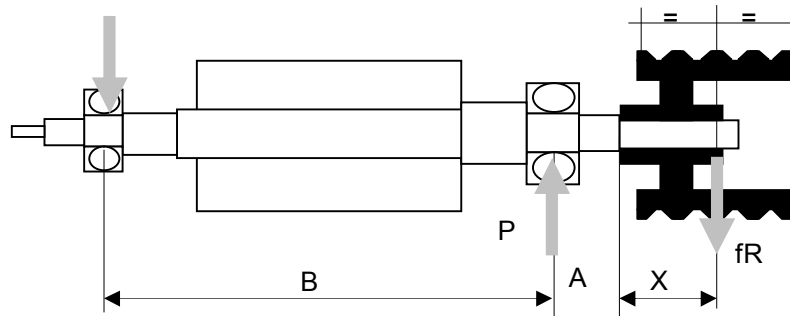

TERMINOLOGY:

- max n = Maximum speed
- n = Working speed
- L10h = Bearing service life, in h
- C = Rated dynamic load of bearing
- max P = Admissible radial load on bearing for L10h and n
- max Fr = Maximum radial force on pulley

(*) Supply on request

(**) The maximum radial force on the pulley is lower than the values of the selected set of bearings

(***) Ball bearings without blanking plates.

Ball bearings with ZZ blanking plates are greased for their entire service life.

Roller and ball bearings without blanking plates must be greased regularly with KP2N-40 lithium soap-based grease according to DIN51825.



PRECAUTION

If the admissible loads are exceeded for the forces on the end of the shaft, damages may occur to the mounting parts and the machine. Damages may also occur to the cylindrical roller bearings when the transversal forces are lower than the established minimum.

Check the admissible loads according to the data given in the catalogue.

Radial load according to speed

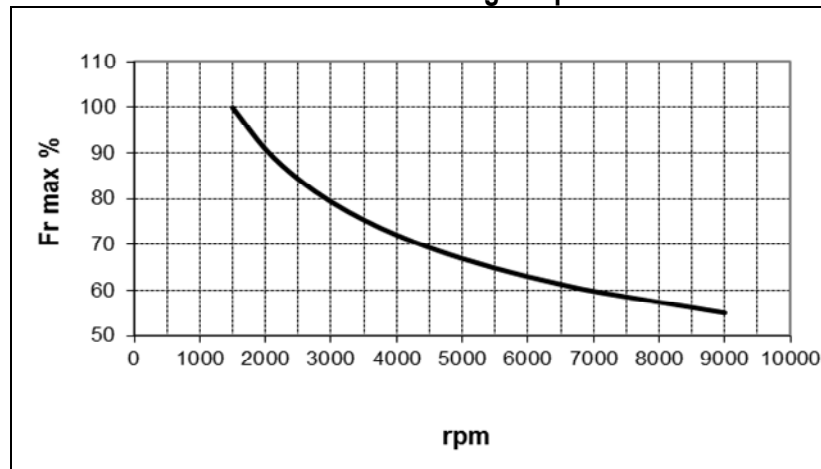

Figure 3: Admissible radial loads

Motors with a shaft height of 160 and above carry a standard earth connection brush to prevent problems caused by bearing currents. There is also the option (on request) for incorporating insulated bearings with external greasing. VASCAT recommends incorporating this type of bearing in motors with powers that are equal to or greater than 100 kW.

A motor may need some type of special execution (considered as non-standard) that includes a bearing different to those specified above. In said case, the customer must check with VASCAT to make sure that he has all the relevant information.



3.7 Electrical specifications

3.7.1 Windings and insulation

MAC QI/QE/QX motor coil windings are made up of copper wires with two coats of polyamide varnish > 220°C and/or THEIC-Polyesterimide with Amide-Imide > 200°C, rated with H-type insulation class.

They are impregnated using single-component epoxy resins that polymerise on the basis of temperature, also class H.

The windings are insulated from the stator core using NMN sandwich-type paper (Nomex-Mylar-Nomex). The outer parts of the sandwich (Nomex) are fibres, whereas the core (Mylar) is a plastic film of polyethylene terephthalate. Special care is also taken with the insulation between each phase.

This insulation system guarantees appropriate dielectric resistance for the motor to work with frequency converters, even on the most critical applications.

3.7.2 Connections

The connections between the windings and the terminal box are made using a flexible cable coated with ETFE capable of withstanding up to 150°C. The connections are welded using a FUSBAT650 rod. The welds of the contacts are also protected by a double layer of fibreglass insulation pipe with class-H acrylic impregnation.



3.7.3 Power-supply conditions

MAC-Q motors are designed to work with a power supply via frequency converters and they can withstand BUS DC voltages (after rectifying the mains voltage) up to 700 VDC (500 VAC).

With regard to admissible voltage surges, MAC motors can withstand a B-type peak voltage on terminals, as described in the following graph from technical specification TS 60034-25 of the IEC:

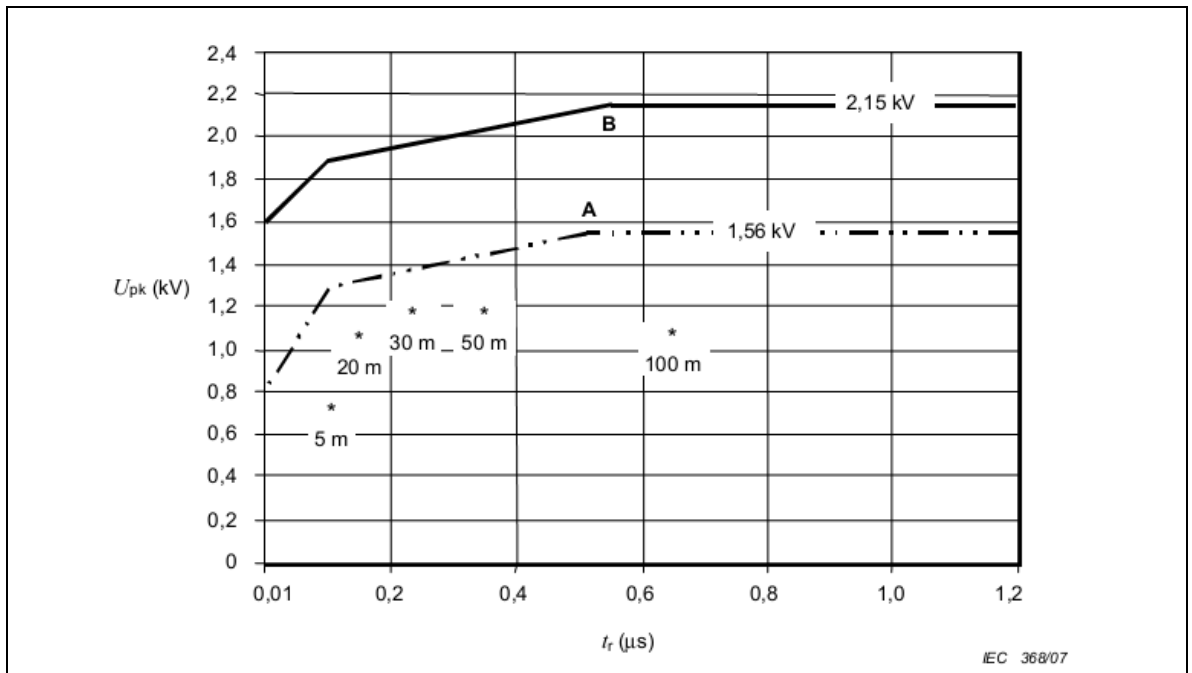

Figure 4: Admissible voltage surges

Limiting surge voltage curves measured between two phase terminals of the motor according to the peak rise time.

Curve B = Without filters for motors up to 690 VAC.

Furthermore, the drive switching frequency connected to a MAC Q motor must be at least as summarised in the table below:

Power	Rated speed	Switching frequency
$P \leq 150$ kW	>3000 rpm	4 kHz
$P > 150$ kW	>2000 rpm	2 kHz

Table 18: Admissible switching frequency

Otherwise, the rated features of the motor, shown on its nameplate, must be derated. Please check with VASCAT to determine the resulting values.



3.7.4 Standard thermal protection

MAC Q motors include a PTC140-type thermistor on their stator windings. It is a solid-state device whose resistance varies significantly with temperature and provides a *Contact Open (OFF) / Contact Closed (ON)* type logical signal depending on whether or not the temperature of the motor windings exceeds the reference temperature of the sensor, in this case 140°C.

Its operation curve is as follows:

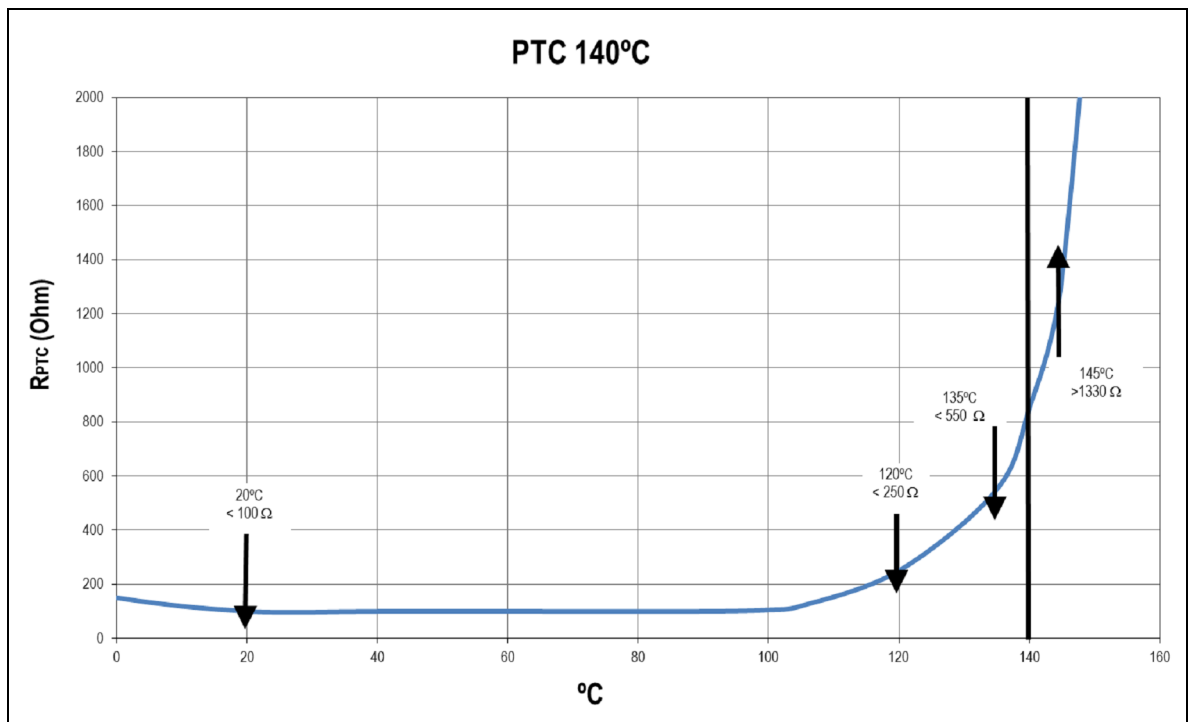

Figure 5: Characteristic curve of a PTC140

Said ON/OFF logical signal can be used by an external control circuit to process an alarm system to prevent the motor from overheating.

3.7.5 Optional thermal sensors

The installation of other types of linear temperature probes is also possible on request. For example, KTY84-130 type sensors can be installed on the windings, as well as PT100 sensors on the windings and/or bearings, which would monitor the operating temperature at all times. The following graphs correspond to said sensors.

Please check with VASCAT for each specific case.

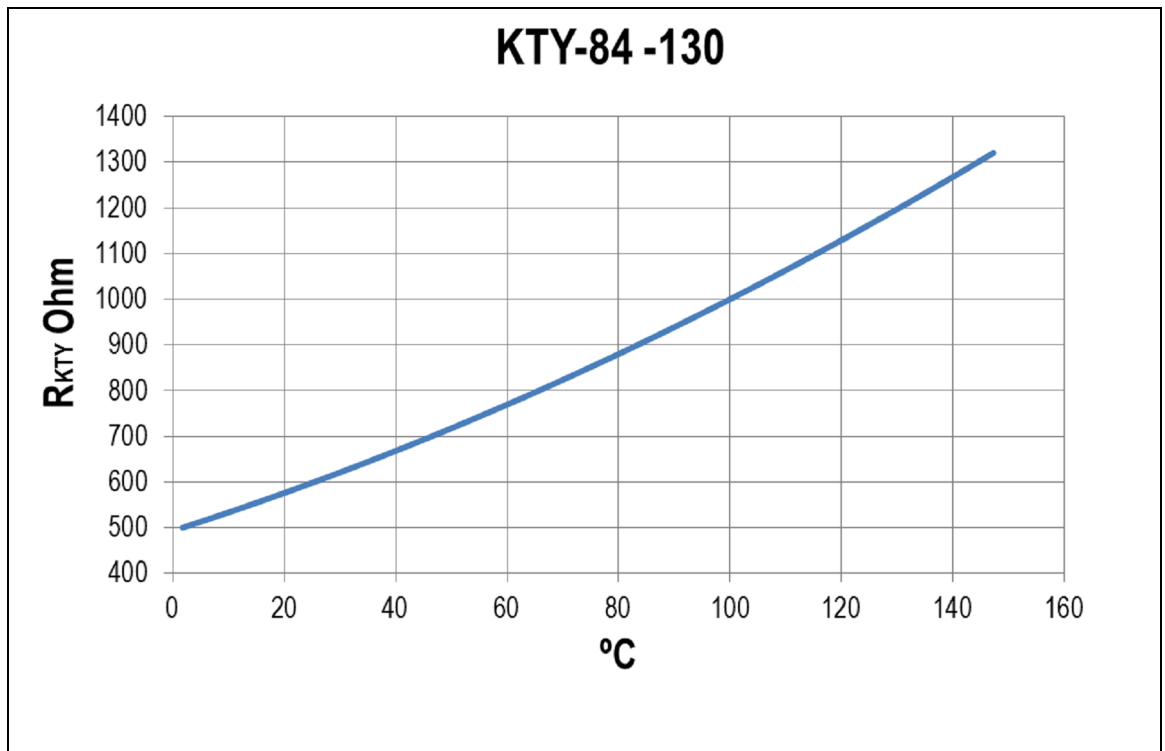

Figure 6: Characteristic curve of a KTY-84-130

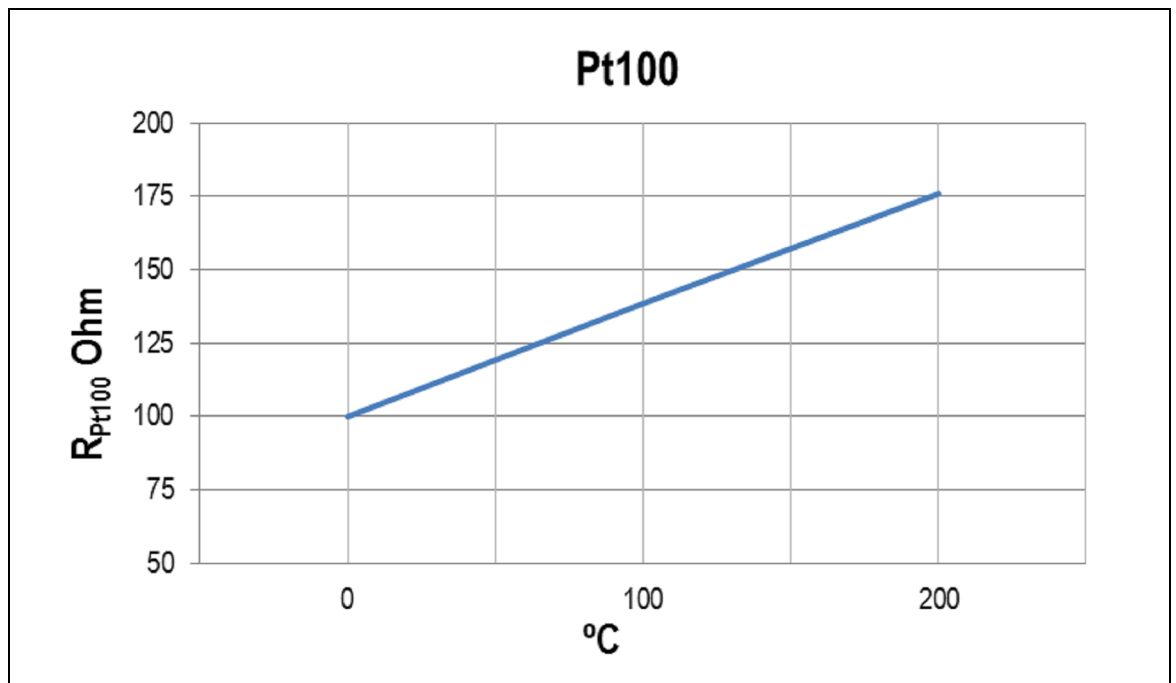

Figure 7: Characteristic curve of a Pt100

3.7.6 Anti-condensation heaters

As an option (on request), one or two heating elements can be installed on the winding heads to prevent condensation on the motor windings when the motor is to be installed at a site with high relative humidity (> 85%).

The standard VASCAT type is 50 W 230 VAC.



3.7.7 Fan and pressure gauge

MAC Q series motors are air-cooled using a forced ventilation system that includes an electric fan powered independently from the motor.

The fan on the MAC QI/QE/QX series motors can be installed in the following positions:

Motor	Circulation direction	Standard position	Optional positions
MAC QI	Impulsive	<p><i>Top rear</i></p> 	<p><i>Side rear</i></p> 
MAC QE	Suction	<p><i>Axial</i></p> 	--
MAC QX	Suction	<p><i>Axial</i></p> 	--

Table 19: Fan position

Other mounting options are possible on request.

The standard versions of these units are powered with single-phase or three-phase alternating current (see motor technical data sheet for more information). Other ventilation methods can be studied on request.

Radial electric fans incorporate a washable filter to prevent incoming particles from damaging the motor. This filter requires regular maintenance (see subsequent sections). This type of fan can include, (on request) an anemostatic relay (pressure gauge) with a set of NC/NA contacts that open/close when the airflow is insufficient.

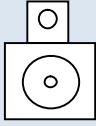
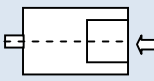
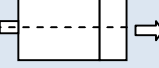
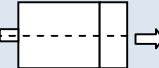

3.8 Accessories

3.8.1 Feedback sensors

MAC Q series motors can be fitted with different types of feedback sensors. As standard models, VASCAT offers the following incremental optical encoders:

Specifications	Type A	Type B	Type C
Number of pulses per revolution	1024 / 2048	1024 / 2048	1024 / 2048
VDC power supply voltage	5	10 ÷ 30	5
Output logic	RS422 TTL Line driver	Push-Pull HTL	Sin/Cos 1Vpp
Output voltage High level	> 2.5 V	> VDC- 3 V	-
Low level	< 0.5 V	< 2.8 V	-
Max. output frequency	300 kHz	300 kHz	450 kHz
Load capacity	120 mA	150 mA	120 mA
Maximum cable length	100 m	100 m	150 m
Short-circuit protection	No	Yes	Yes
Operating temperature	-10 / 100°C		
Protection rating	IP64		
Hollow shaft diameter	12 mm		
Male connector (encoder side)	CONIN M23 12 poles with anticlockwise numbering		
PINS			
PIN No.	Signal		
1	B'		
2	VDC sensor		
3	N		
4	N'		
5	A		
6	A'		
7	N.C.		
8	B		
9	N.C. (*)		
10	0V supply		
11	0V sensor		
12	VDC supply		

Table 20: Standard feedback sensors on MAC-Q motors

*Cable screen on cable + connector versions.



In the case of motors up to a shaft height of 160, blind hollow shaft encoders are used with an anti-turn strap system on the stator, mounted to the motor shaft using a ring clamp.

In the case of motors with a shaft height equal to or above 200, solid shaft encoders are used with a coupling flange on the stator and an elastic coupling on the shaft, with thermal and galvanic insulation.

When specifically requested by the customer, other types of encoders and/or feedback sensors can be fitted. Please check with VASCAT for each specific case.

3.8.2 Parking brake

MAC Q series motors can be fitted, as an option, with an electromagnetic parking brake to immobilise the motor load safely and in a way that is 100% external to the operation of the motor itself.

On certain occasions, this is necessary for safety reasons, e.g. when it is necessary to block the movement of the machine to work on the interior safely or when there is a fault in the converter power supply or other mechanical devices of the installation.

PRECAUTION

The use of the parking brake as a dynamic working brake, e.g. to slow down a load, is not allowed, since it speeds up the premature wear and tear of the lining.

In general, the brakes used by VASCAT are powered at 24 VDC (please check the technical datasheet of each motor), working via the activation of coils on springs. This type of brake works according to the lack of voltage operating principle, i.e. when there is no voltage applied, the brake blocks the rotation and when voltage is applied, it is unblocked.

PRECAUTION

If the appropriate voltage is not applied to the brake, it will not work correctly. In the case of insufficient voltage, it will overheat due to friction, causing rapid wear and tear of the lining. If the voltage is too high, the windings may be damaged by surge currents.



PRECAUTION

The brake power circuit must be completely independent.

Make sure that the brake is not activated before the motor rotates and that it remains connected to voltage when the motor is rotating. If, for any reason, the power supply to the brake continues when the motor is stopped, the brake will not work and, as the shaft would be free, undesired movements may occur.

The correct use of the brake is the user's responsibility and that of the manufacturer of the electrical control cabinet.

The specifications of the standard brake for each type of motor are specified on the corresponding technical data sheet, which can be consulted on VASCAT's website: <http://www.vascat.es>.

NB

The friction surfaces must always be kept free from oil and grease, since minimum quantities of such substances can largely reduce the brake torque.



3.8.3 Noise level

The technical data sheets VASCAT provides for each motor show the noise level in dB issued by each model.

Optionally, motors can be fitted with a kit to reduce the level of noise emissions. Please check with VASCAT for more details.

The machines directive specifies a noise level of 80 dB at work posts. The user is responsible for guaranteeing said level using the installation of external absorption devices if necessary.



4. SHIPMENT, RECEPTION, TRANSPORT AND STORAGE

4.1 Shipment

MAC QI/QE/QX motors are shipped in completely closed packaging, including a wooden pallet that has been given phytosanitary treatment. The specific type of packaging may vary according to the destination and the type of transport used.

In general, for road transport, the packaging consists of a box of dual-layer corrugated cardboard, clipped and tied with a heat-sealed strap on the palate; for transport by sea or air, it consists of a wooden box that has been given phytosanitary treatment fastened to the pallet using nails or screws.

By request, other types of packaging may be considered according to the customer's specifications.

Please check with VASCAT for more details of each shipment.

4.2 Reception

When the goods have been received, the customer is responsible for checking that the packaging has not been damaged and is in perfect condition. If that is not the case, the circumstance must be recorded on the haulier's delivery documentation and a claim must be filed immediately with the haulage company for the damages that have been caused.

When it has been removed from the packaging, the material must be checked to ensure that it has been delivered in accordance with the details on the documents sent with the shipment, together with the fact that it is in a correct state of repair. Otherwise, a claim must be filed immediately with VASCAT for the faults that have been seen or for an incomplete shipment.

VASCAT declines all responsibility for damages claimed thereafter.

NB

Do not start up a machine that has been damaged under any circumstances.
--



4.3 Transport

The machine must be transported always in accordance with the following instructions:



WARNING

Transport and lifting of the machine by the eyebolts only

For the correct handling of the motor, several eyebolts have been fitted on the top of the housing exclusively for said purpose. Therefore, do not lift the motor using the shaft or the fan casing under any circumstances.

To lift the machine, use guide devices (cables, chains or slings) with safety hooks on the ends. See diagram:

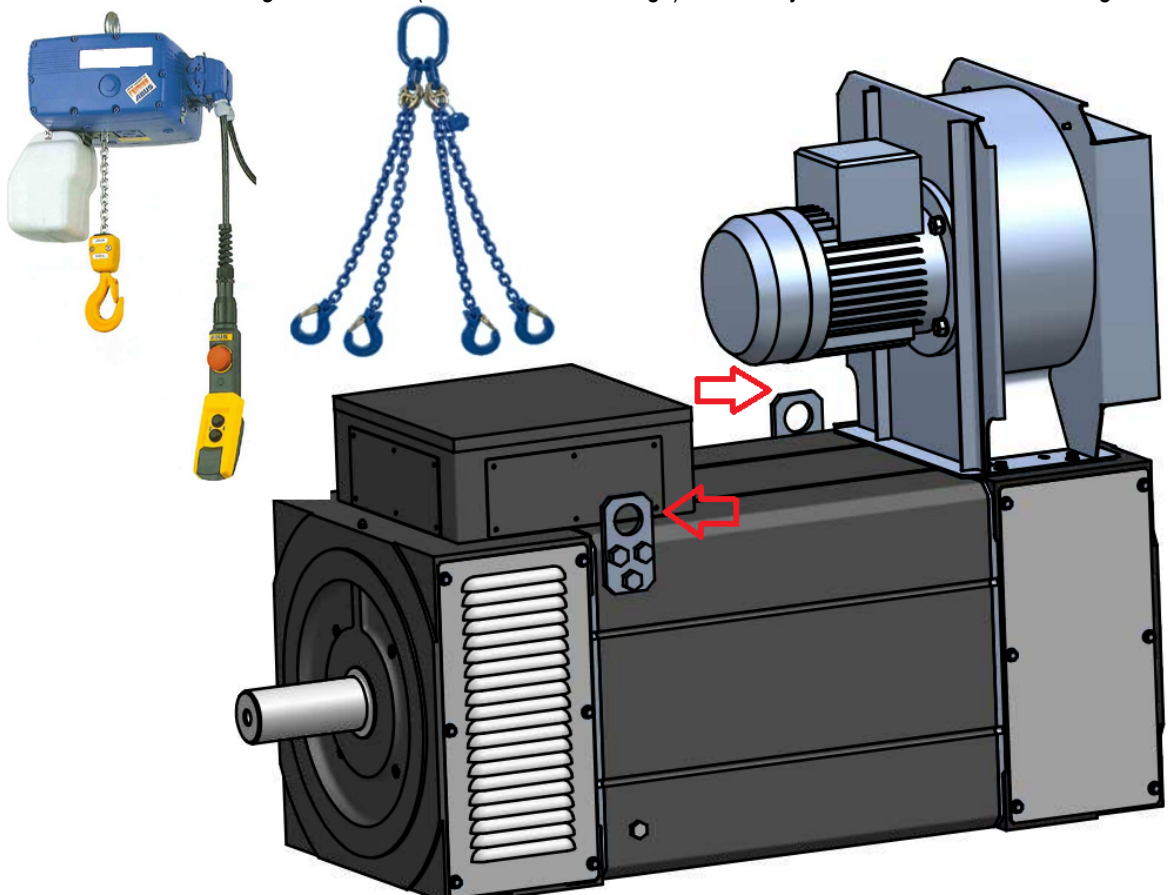

Figure 8: Transport and lifting of the motor

The lifting apparatus and guide devices must have sufficient load capacity to lift the machine. Please see that technical data sheet for the motor to know how much each model weighs.

Sudden movements and knocks must be avoided during transport.



4.4 Storage

MAC QI/QE/QX motors can be stored for long periods (up to 2 years) without their specifications being affected. They must be stored in a dry, dust-free place with no aggressive atmosphere or vibrations and no sudden temperature changes.

PRECAUTION

Damages caused by outdoor storage

The machine may be damaged if it is stored outdoors.

The machine must be stored only in indoor areas that meet the following conditions:

- They must be dry, dust-free, icing proof and have no vibrations. The relative humidity of the air must be below 60%; in accordance with EN 60034-1, the temperature must not be below -15°C.
- It must be well ventilated.
- It must provide protection against extreme bad weather.
- The ambient air must not contain aggressive gases.

The machine must be protected against knocks and humidity and its entire surface must be appropriately covered.

If the machine cannot be stored in a dry place, the following measures must be adopted:

- Cover the machine using a plastic film or similar with a drying material (silica gel) inside.
- Package the unit in a sealed box.
- Place several bags of drying agents in the sealed box. Check the drying product regularly and replace it as necessary.
- Control the humidity level in the sealed packaging by placing indicators that show the air humidity level in the packaging at different levels.

If the machine is to be stored for a relatively long period (more than 6 months), it must be checked regularly (every 3 months) to ensure that it is in a perfect state of repair and that there are no faults. The required maintenance work must be carried out and the storage enclosure must be climate-controlled.

Before packaging the motor, VASCAT applies a thin film of blue removable lacquer on the end of the shaft and the machined surfaces. This product protects the materials against corrosion. If it is to be stored for a long period, do not remove the protective film.

PRECAUTION

Damage caused by condensation water

Condensation water may gather in the machine owing to important variations in ambient temperature, direct sunlight or high air humidity levels during storage.

If the stator winding is damp, its insulation resistance is reduced. This leads to disruptive discharges that can destroy the winding. Furthermore, condensation water may form oxide or mould inside the machine.

This is why it is important to follow VASCAT's storage recommendations to the letter.



5. INSTALLATION AND START-UP

PRECAUTION

Damage caused to bearings as a result of long storage periods

If the machine has been stored for more than 3 years in good conditions (dry, dust-free place, etc.), the grease on the bearings must be changed, if they need re-greasing, or the bearing should be changed if it is a bearing with lubrication for its entire service life. If the machine has been stored in poor conditions, the change or re-greasing of the bearings may be necessary before the aforementioned period.

The following describes the conditions that are necessary for the installation and start-up of the machine.

5.1 Motor installation

5.1.1 Site

A correct site is essential for guaranteeing a long motor service life. The use of the motor in an incorrect site could shorten its service life considerably. The following are some points to bear in mind when choosing the correct site for the motor:

- a) The chosen site must comply with the ambient temperature range and altitude for which the motor was selected (for more details, see section 3.5.3).



HOT SURFACE

The exterior surface of the motors can reach temperatures of more than 60°C and, therefore, the appropriate precautions must be taken to avoid accidental contact (the motor bears a plate indicating said circumstance).

- b) The site must have a humidity level of less than 85% to prevent condensation appearing on the surface. If the humidity levels at the site exceed 85%, the motor must be fitted with anti-condensation heaters (see section 3.7.6).
- c) The air inlet and outlet must not be blocked. There must be no recirculation of hot air from the outlet to the inlet.

PRECAUTION

Damages caused to the motor by blocking the airflow at the active fan inlet

Damages may be caused to the motor if there is an insufficient airflow at the active fan inlet due to the selection of an incorrect site for the machine. If the machine does not have sufficient cooling airflow, the windings may overheat and the corresponding consequences may arise.



5.1.2 Mounting

Correct mounting is essential to guarantee a long service life for the motor. The following are essential issues that need to be taken into account when anchoring the motor correctly:

Assembly using IM B3 foot mounting type:

- a) Ensure that the support base is correctly levelled: the motors must be mounted on a solid, flat base that is perfectly level. If the base is not made up of one single compact surface, the motor foot support services must be on the same level. To level the machine correctly, the foot may have to be gauged using steel plates to avoid the appearance of mechanical tension.

PRECAUTION

Damages caused to the motor by the incorrect levelling of the support base

The incorrect levelling of the motor reduces the service life of the bearings and other parts of the transmission.
--

- b) Use an appropriate base for the assembly work: Make sure that the base on which the motor is to be located meets the following specifications:
- The dimensions of the base correspond to those of the motor foot. Make sure that the entire area of each of the 4 motor feet rests perfectly on a solid base.
 - Make sure that the base is capable of supporting the weight of the motor without problem. If the base were to go out of shape over time, the motor may not be level, which would reduce the service life of the motor substantially, especially the bearings.
 - Make sure that the base is sufficiently heavy-duty to counter the torque provided by the motor without noticeable deformation.
 - Make sure that the base is sufficiently rigid for there to be no resonances in the motor operation speed range.
- c) Make sure that there are no additional loads on the motor: Consideration must be given to the weight of the couplings and pulleys and the resulting axial and radial loads to ensure that the motor bearings are dimensioned correctly (the maximum admissible radial loads for each motor are specified in the Table 17).
- d) Fastening the feet: When the motor has been installed on a base that meets all the aforementioned, the motor must be firmly fastened in position using the 4 holes machined on the feet (for said purpose) and bolts of the appropriate size for said holes. The diameter of the holes machined on the motor feet complies with the motor shaft height according to the EN 60072 standard. The feet bolts must be selected according to the loads applied to the motor and in compliance with the ISO 898-1 standard, which defines the mechanical properties of the bolts according to their quality.



Fastening using IM B5 or IM B14 flanges:

- a) Remove the anti-rust varnish: First of all, clean the surface of the flange before fastening.
- b) Connect and fastened the counter-clamp: For correct fastening, use bolts with an appropriate diameter in accordance with the dimensions of the clamp as per the EN 60072 standard.
- c) Make sure of the perpendicularity of the machine shaft and the counter-flange plane: Perpendicularity errors must be below 0.05 mm.
- d) Make sure that the counter-flange is appropriate: In accordance with section b) of the IM B3 assembly.

NB
Application of additional loads on the flange
The motor flange is dimensioned only to support its own weight. If there are additional loads, the flange may not be sufficiently heavy duty and, therefore, faults may occur that affect the motor and the machine to which it is coupled.

5.1.3 Machine coupling

The motor must be coupled to the machine very carefully since it is fundamental in order to ensure the correct service life of the motor.

Before mounting the coupling, remove the protective lacquer and clean the surface well.

PRECAUTION
Damages to the motor bearings
Prevent solvent from entering the interior of the bearings since they could be damaged.

If the motor works with a direct drive (coupled directly to the load), the appropriate coupling must be used to compensate the alignment errors and radial forces that are applied. Please check with VASCAT S.A. in case of doubt.

In any case, make sure that the alignment between the motor shaft and that of the machine corresponds to the coupling between both parts.

PRECAUTION
Damages to the shaft and bearings
Excessive misalignment can cause overloads on the bearings and break the shaft or cause the bearings to seize up through fatigue. The customer is responsible for ensuring the correct alignment of both shafts.

VASCAT motors and rotors are dynamically balanced using a half-key on the end of the shaft (in accordance with the 60034-14 standard). To ensure the correct balance of the entire transmission unit, all the parts of the transmission system must also be balanced (pulley, coupling, etc.).

The installation of the coupling or the transmission element must be made gently without knocking, previously heating the pulley or using an appropriate tool (please see Figure 9).

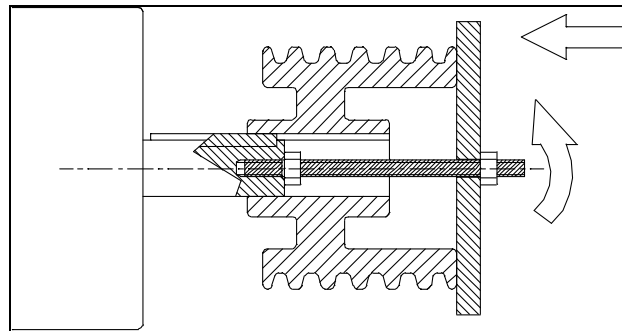

Figure 9: Fitting the coupling

PRECAUTION

Damages to the motor bearings

If the motor shaft is knocked, the bearings may be damaged.

If belts are used for the transmission of the torque or a gear with radial load, make sure that the admissible radial load is not exceeded on the motor shaft. The specific data for the admissible radial loads for each size of motor can be found in the Table 17 description of the bearings given in previous sections.

PRECAUTION

Damages to the motor bearings

If the maximum value of the admissible radial load is exceeded, the shaft may break and the bearings may seize up due to fatigue. The customer is responsible for making sure that the tension of the transmission belts does not exceed the established limits.



5.2 Electrical connections



WARNING

All the work must be performed by responsible, skilled personnel and when the motors are completely stopped and isolated from the mains. Always check that there is no voltage!

PRECAUTION

Damage to the windings

Before the connection, check the status of the insulation elements of the windings with regard to earth, since long or inappropriate storage or transport may have caused the motor to absorb humidity, which affects the capacity for insulation.

The insulation reference values considered safe by VASCAT are as follows:

Parameters	Reference values
Recommended measurement voltage	500 V
Minimum insulation resistance with new or repaired windings	60 MΩ

Table 21: Insulation reference values for MAC-Q motors

If the humidity or dirt returns a value below the specified figure, the windings must be cleaned or dried until measurements in the safe range are obtained.



WARNING

Dangerous voltage

When measuring the resistance of the winding insulation and just after the measurement, the terminals are live. Contact with any live part may cause serious injury or even death.

Do not touch the terminals during the measurement process or immediately afterwards. Before any contact, discharge the terminals to earth using an insulated cable.



5.2.1 Connector strips and terminals

The motor has a terminal box with the corresponding electrical connector strip and connection bolts for the current of each motor.

The table below summarises the different types of terminal boxes, strips and terminals that correspond to the standard execution of each shaft height of the MAC Q motors.

MOTOR	CABLE SECTION	TERMINAL	TERMINAL STRIP	TIGHTENING TORQUE	TERMINAL BOX
MAC QI/QE/QX 100	2x2.5 / 1x4 / 2x1.5	1 of 4-6 M6	M6	4Nm	120x120x45
	1x2.5 / 1x1.5	1 of 2.5 M6	M6	4Nm	120x120x45
MAC QI/QE/QX 132	2x10	1 of 25 M8	M8	8Nm	180x180x60
	1x10 / 2x4 / 2x6	1 of 10 M8	M8	8Nm	180x180x60
	1x6 / 2x2.5 / 1x4 / 1x2.5	1 of 4-6 M8	M8	8Nm	180x180x60
MAC QI/QE/QX 160	2x16	1 of 35 M12	M12	20Nm	300x300x120
	2x10	1 of 25 M8	M8	8Nm	300x200x80
	2x6 / 2x4	1 of 10 M8	M8	8Nm	300x200x80
MAC QI/QE/QX 200	6x16	2 of 50 M16	M16	40Nm	300x300x120
	4x16 / 6x10	1 of 70 M16	M16	40Nm	300x300x120
	3x16 / 4x10	1 of 50 M16	M16	40Nm	300x300x120
	3X10	1 of 35 M12	M12	20Nm	300x300x120
	2x10 / 2x16	1 of 25 M12	M12	20Nm	300x300x120
	3x6 / 3x4	1 of 16 M12	M12	20Nm	300x300x120
MAC QI/QE/QX 250	6x16	2 of 50 M16	M16	40Nm	380x380x210
	4x16 / 6x10	1 of 70 M16	M16	40Nm	380x380x210
	3x16 / 4x10	1 of 50 M16	M16	40Nm	380x380x210
	3X10	1 of 35 M12	M12	20Nm	380x380x210

Table 22: Standard terminals and boxes on MAC-Q motors

By request, modifications can be made to the values specified in the table.

The motor power connections must be made with a cable section that corresponds to the rated current of the motor and in accordance with the schematic provided on the interior of the terminal box cover of each motor.



5.2.2 Connection diagrams

The connection schematics of the terminals in the terminal box for standard versions of the MAC-QI/QE/QX motors are as follows:

XX1 windings (Star)

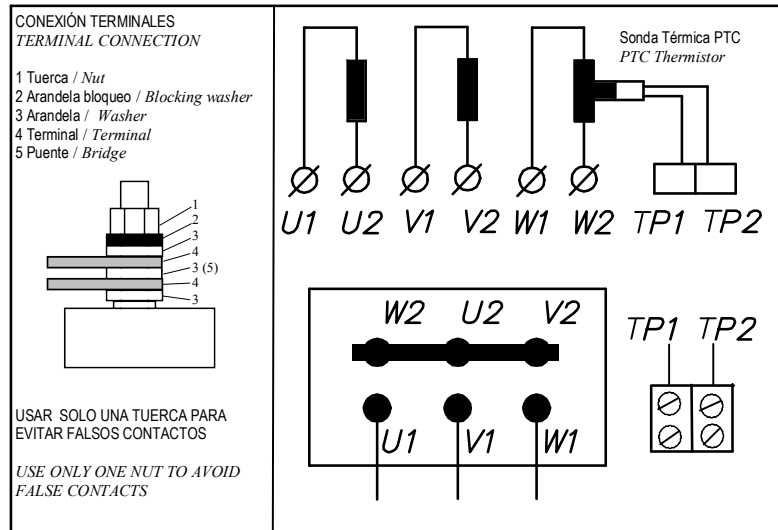

Figure 10: Motor connection schematics with star-type windings

XX2 windings (Delta)

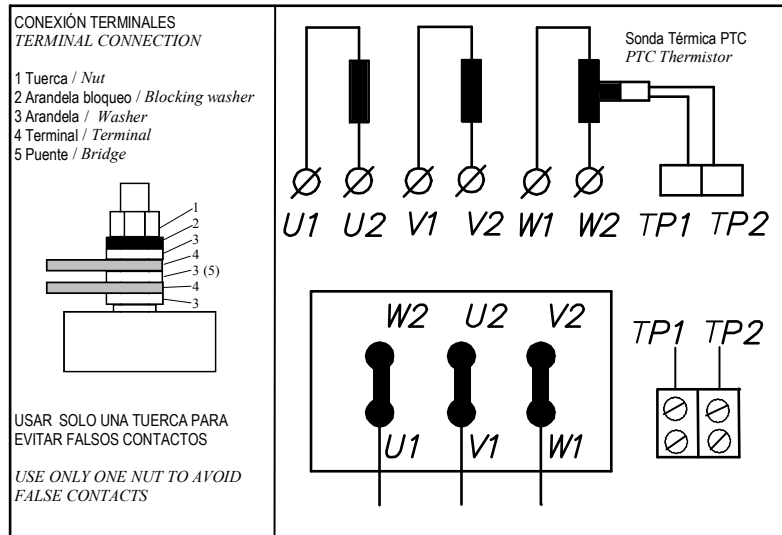

Figure 11: Motor connection schematics with Delta-type windings

When other optional elements are incorporated (e.g. additional sensors, anti-condensation heaters, etc.), these schematics may vary slightly.



5.2.3 Power cables

The inputs of the power cables that are to be connected on the motor terminal box strip and the converter terminals must comply with current regulations. For the protection rating, type of cable-laying, allowed cable diameter, connection, etc., VASCAT recommends the use of symmetrical structure screened cables in accordance with technical specification IEC TS 60034-25.

The cable screen must be made up of the maximum possible number of individual conductors and it must have good conductivity. Twisted copper or aluminium screens are particularly suitable.

The following shows a schematic with the various examples of screened cables and their connections:

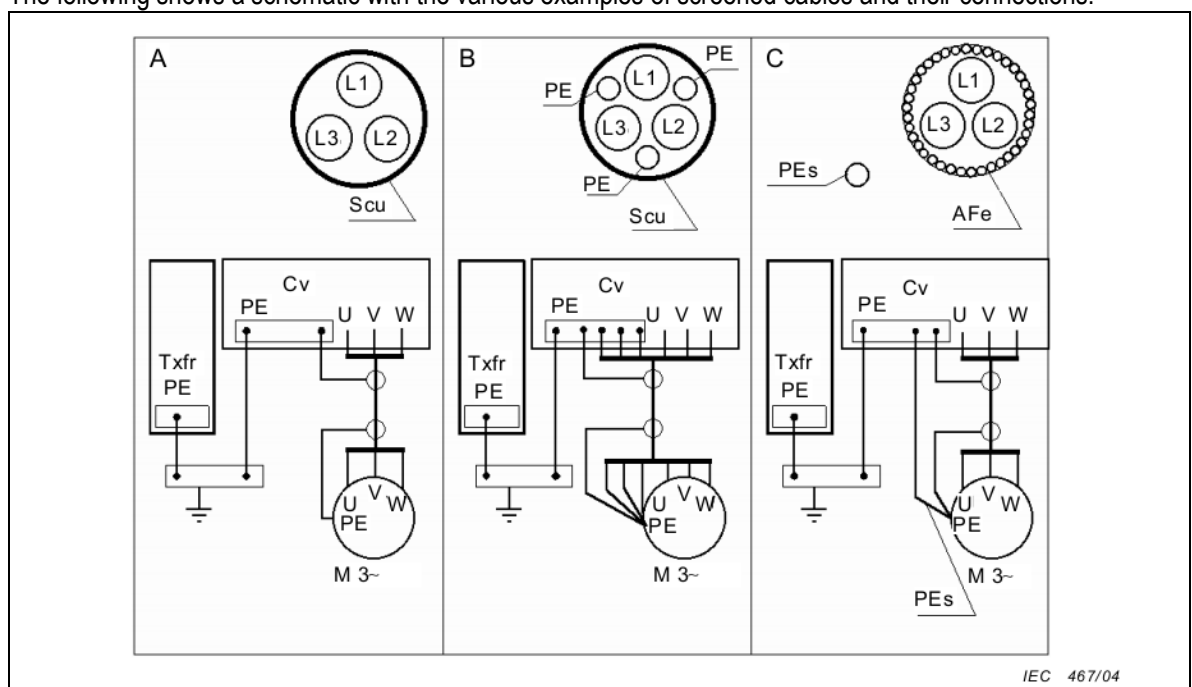

Figure 12: Recommended power cables and connections

Scu - Copper or aluminium screen AFe - Steel structure Txfr - transformer Cv - Converter PEs - Separate earth cable

As shown in the above figure, the power cable screen must be connected on both sides (motor and converter).

The screen connections must be made bearing in mind that they must cover a wide surface of the screen to create a 360° contact using gland boxes for low impedance through a wide range of power levels. Make sure that the screen is HF (for high frequencies). All the foregoing effectively reduces the voltages of the shaft and the housing, creating good derivation of the high frequency currents. This will reduce the currents that will pass through the bearings. Consideration must be given to the fact that the ends of the unscreened cable must be kept as short as possible.

PRECAUTION

Damages to the motor bearings

If the distribution of the earth conductors is not appropriate, current may flow through the bearings and deteriorate the parts of the bearing in only a few months.



The following two figures show the recommended terminations for screened cables:

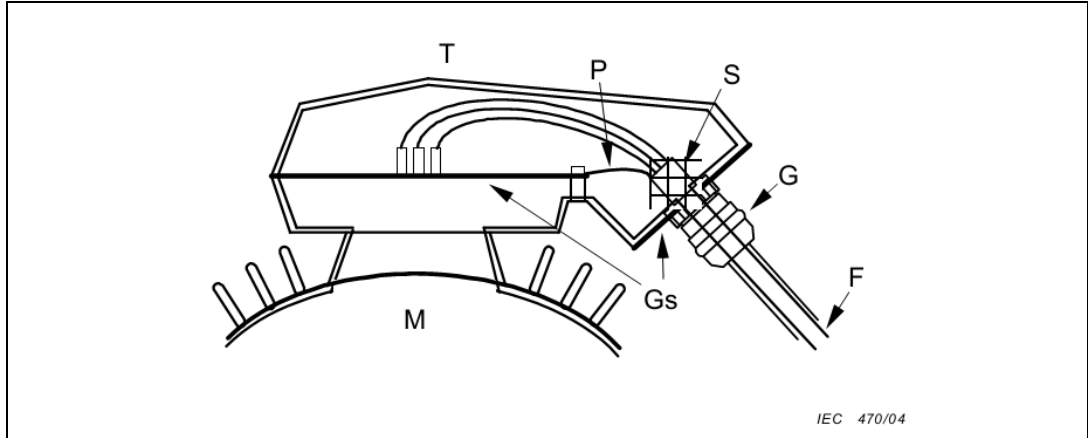

Figure 13: Recommended terminations

T – Conductor material terminal box S – Cable screen P – Earth cable M – Motor body
Gs – Conductor seals G – EMC gland seal F – Continuous Faraday box

The connection between the power cable screen and the motor terminal box must be made using either of the two methods shown in the following figures (on the left with an EMC gland seal and, on the right, with the screen connected to the terminal box using a clamp):

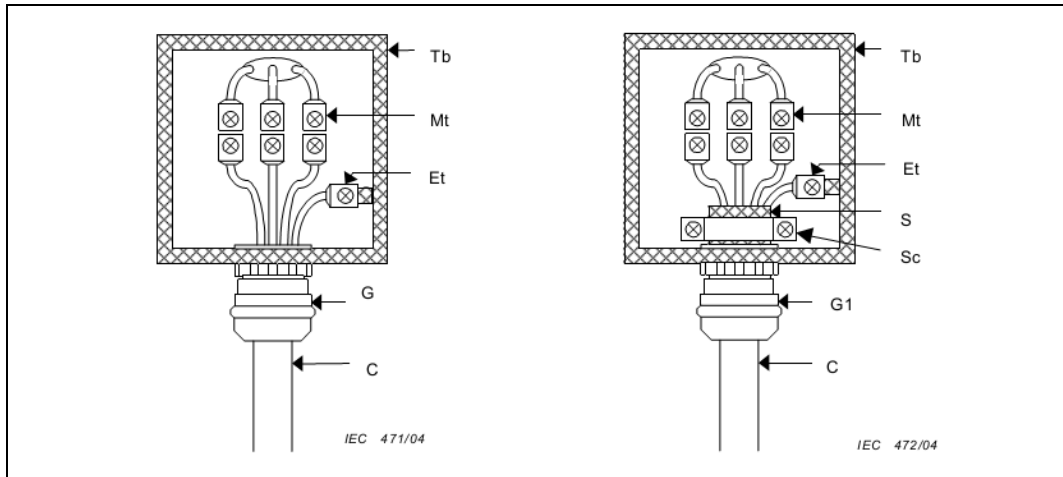



Figure 14: Recommended connections in the terminal box

Tb – Terminal box Mt – Motor terminals Et – Earth terminal S – Cable screen
Sc – Screen bracket G – EMC gland seal G1 – NON-EMC GLAND SEAL C – Cable

The earth protection conductor must be connected to the terminal indicated for said function.

 **DANGER**
A poor earth connection involves a severe risk of electrocution through accidental contact with the motor surface.



5.2.4 Connections for the fan, thermal sensors and accessories

The fan motor cables must be connected in accordance with the specified voltage or that given on the fan motor nameplate (MAC QI motors) or the main motor nameplate (on the MAC QE and MAC QX motors).

To connect the thermal sensors, use terminals of 1.5 mm² on the tip and connect them to the corresponding nylon strip.

Where necessary, connect the encoder according to the schematic provided on the interior of the terminal box.

Where necessary, connect the brake cables in accordance with the voltage specified on the motor nameplate. The connection on the MAC QI motors is made using a nylon strip attached to the brake body; on the MAC QE and MAC QX, there is a connector on the top of the fan housing.

5.2.5 Final checks

Before closing the terminal box, check that:

- The electric connections in the terminal box are fastened tight in accordance with the above and the fastening torques given in Table 22.
- There are no protruding wire ends.
- The power cable screens are correctly connected.
- The interior of the terminal box is clean and free from leftover cables.
- All the seals and blanking surfaces are intact.
- The connection cables are positioned in such a way that they leave a certain amount of room for movement and that none of the cables are tight or connected in a 'forced' way.
- The connections between the terminals and the cables are correct.
- The inputs that are not used are fully closed.

After closing the terminal box cover:

- Make sure that the closing elements are fastened tight.



5.3 Start-up

5.3.1 Preliminary checks

Before starting the motor, check the following:

- The motor is correctly aligned, fastened and coupled (the belt tension is correct in the case of belt transmission or the radial profile and tooth flank profile is adequate in the case of gear transmission).
- All the necessary measures are in place to prevent direct contact with moving or live parts.
- Service conditions correspond to the information provided on the motor specifications plate.
- The earth and equipotential connections have been made correctly.
- The electrical connections are tightly bolted.
- All the power cables and their respective shields are correctly connected.
- The other cables (cables from the encoder and fan, etc.) are also correctly connected.
- The frequency converter configuration guarantees that the maximum rotation speed shown on the motor specifications plate will not be exceeded.
- The machine cooling system operates correctly (rotation direction, rpm, etc.). Also check that the air inlet and outlet are unblocked.
- If there is a brake, check that it works correctly.
- The motor is connected to operate in the correct rotation direction.
- There is a correct reading of the motor safety devices (thermal sensors).
- The frequency converter is correctly configured: Check the drive configuration data with the specifications plate and the technical datasheet.



5.3.2 Start-up



WARNING

Skilled personnel

All the preliminary work must be carried out by skilled personnel and when the motors are completely stopped and isolated from the mains. Always check that there is no voltage!

If the mains power cables are connected make sure there is no voltage and that no power voltage can be applied in any way.

PRECAUTION

Damage to the motor

Before starting up the motor, check that there are no elements blocking the rotation of the motor.



MOVING ROTATING PARTS

During start-up and while the motor is in operation, the customer is responsible for taking precaution to avoid accidental contact with the rotating parts.

Proceed as follows to start up the motor:

- 1- Start-up the drive auto-tuning procedure so that it can recognise the motor (see drive documentation for more details).
- 2- If the auto-tuning procedure is completed successfully, start the motor rotating at low speed. Check that the motor behaves satisfactorily and that there are no strange noises or vibrations.
- 3- Gradually increase speed to rated values.
- 4- After several hours in operation, check that the thermal behaviour of the motor corresponds to the motor service type. If in doubt, please contact VASCAT.



6. MAINTENANCE

This chapter describes the preventive maintenance operations for MAC-QI/QE/QX motors. VASCAT declines all responsibility for faulty maintenance performed by the end user.

6.1 Safety instructions

	WARNING
Skilled personnel	
<p>All the cleaning and maintenance work must be carried out by skilled personnel in observance of the safety regulations that apply to the machine coupled to the motor and when the motors are completely stopped and isolated from the mains.</p> <p>Always check that there is no voltage! If the mains power cables are switched-on, make sure there is no power voltage and that no voltage can be applied in any way.</p>	

6.2 Maintenance operations and frequency

Activities	Service intervals and terms
Basic inspection	<i>Every 500 service hours or at least every 6 months</i>
Cleaning of the fan and air filter	<i>Depending on the level of local and environmental dirt</i>
Re-greasing of the bearings (Only on motors where it is necessary)	<i>See regular lubrication label and re-greasing equation (section 6.2.3 of this manual)</i>
Replacement of bearings	<i>Replacement after 20,000 service hours</i>

Table 23: Maintenance activities

NB
Damages to motor and fan
<p>If the fan air filter is not cleaned correctly or sufficiently regularly, the motor may not be cooled correctly, which will lead to the corresponding breakdowns.</p> <p>Furthermore, the fan wheel must be in a good state of repair and perfectly clean; otherwise, it would be in permanent imbalance when it rotates, leading to a breakdown.</p>

NB
Damages to the motor bearings
<p>If the motor bearings are not re-greased adequately or as regularly as required, the bearings may be damaged irreparably.</p> <p>The bearings have a specific service life. When they have reached the end of their service life, they must be replaced by new bearings that are equivalent to the originals. Otherwise, the motor may be seriously damaged.</p>



6.2.1 Basic inspection

After assembling the motor or after repairing a breakdown, the motor must be inspected approximately every 500 operating hours or at least every six months.

This inspection must consist of basically the following:

With the machine on:

- Check that the motor works according to its rated mechanical and electrical values and that there are no strange noises, vibrations or irregular rotation.

With the machine off:

- Check that no cracks appear in the motor fastening elements.
- Check that the connection terminals in the terminal box maintain an adequate fastening torque as specified in the Table 22.
- If faults are found during the inspection, they must be corrected immediately.

Besides this basic inspection, a number of maintenance tasks must be carried out to ensure that the motor has a long service life. The maintenance operations recommended by VASCAT are as follows:

6.2.2 Cleaning of the fan and air filter

It is important to keep the fan wheel as clean as possible. To do so, apply compressed air to its surface on a regular basis to ensure that there are no unwanted particles deposited on it.

The frequency of the cleaning process will depend on the local and environmental conditions that affect the motor, as well as the frequency with which the motor is used.



MOVING ROTATING PARTS

During the motor fan wheel cleaning operation, the customer is responsible for taking the necessary precautions to avoid accidental contact with the rotating parts.

MAC-QI series motors are fitted with a particle filter of the NGB 290/4 type in the air inlet, which requires regular cleaning. The frequency of this operation will depend on the environment in which the motor is located and the frequency with which it is used.

To wash the filter, it must be removed from the fan and cleaned using compressed air or washed with water and detergent, depending on the type of dirt in the environment. The filter must be replaced after 4 or 5 washes by one that is the same as or equivalent to the original.



6.2.3 Re-greasing of the bearings

Motors of the sizes from 100 to 200 include deep groove ball bearings with blanking plates as standard, greased for their entire service life. Accordingly, re-greasing operations are not required.

The bearings of the MAC QI/QE 250 motors (and, optionally, frame sizes 132, 160, 200), are fitted with deep groove bearings without blanking plates, which do require regular re-greasing.

As an option, electrically insulated ball or roller bearings can be installed and they must be re-greased regularly.

The grease that is to be used on insulated bearings with no blanking plates and roller bearings must be KP2N-40 lithium soap-based grease according to DIN51825 or equivalent.

To determine the amount of grease that is to be inserted during the re-greasing operation, VASCAT provides the customer with the following equation as a guide for determining the grams of grease necessary:

$$m = D \cdot B \cdot x$$

Where:

m: Amount of grease to be inserted during the re-greasing operation [gr]

D: Exterior diameter of the bearing to be greased [mm]

B: Width of the bearing in question [mm]

x: Factor that will depend on the re-greasing frequency (0.002 weekly, 0.003 monthly and 0.004 annually).

VASCAT recommends re-greasing every 500 hours or once a month.

The greasing nipples VASCAT fits to its motors comply with the DIN 71412 standard and are zinc-coated. The types used in standard procedures are as follows:



Figure 15: Standard greasing nipples on MAC-Q motors

NB

Damages to the motor bearings

If greasers containing different thickeners and basic oils are mixed together, the lubricant properties of the resulting grease may be inferior. The same type of grease must be used to lubricate the bearings at all times. Otherwise, the bearings may be damaged.



MOVING ROTATING PARTS

During the re-greasing operation, the customer is responsible for taking the necessary precautions to avoid accidental contact with the rotating parts.



6.2.4 Replacement of bearings

Both the bearings that have been greased for all their service life and those that need to be greased regularly, as well as hermetic parts that are subjected to wear and tear (seals and joints, etc.), where applicable, must be replaced after 20,000 operating hours.

Bearings of the same type as the originals must be installed. Standard bearings for each motor type may be consulted at Table 17.

The procedure for replacing bearings must be carried out as follows:

1. Disassemble the motor from its location and place it in a safe and clean place.
2. Remove the accessories (brake and/or encoder, where applicable) from the motor very carefully so as not to damage them and then remove the terminal box and fan. See following sections for more details.
3. Unscrew the motor seals and covers and remove them.

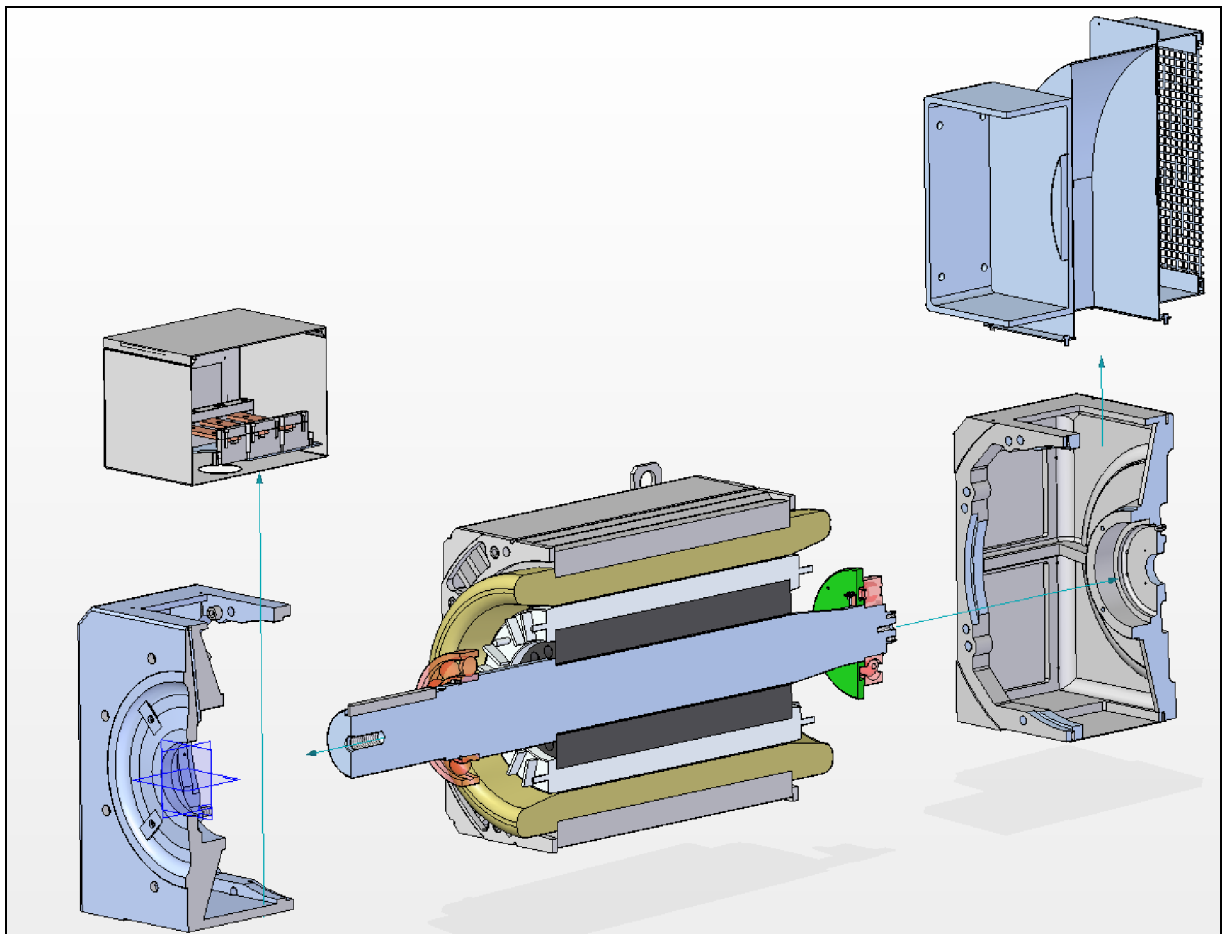

Figure 16: Replacing bearings on MAC-Q motors (step 3)

4. Remove the rotor from the interior of the stator, taking care not to damage the windings.

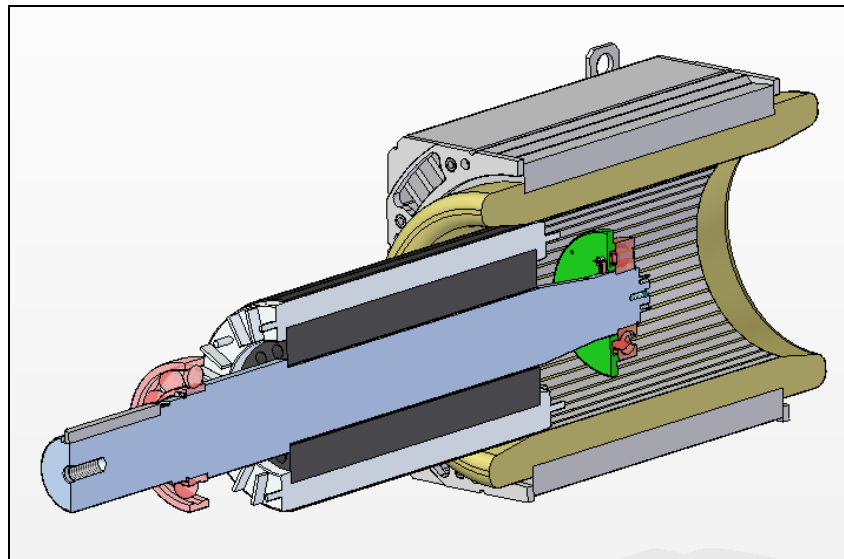

Figure 17: Replacing bearings on MAC-Q motors (step 4)

5. Put the rotor in a stable place so that it does not turnover.
6. Remove the bearing shim washers.
7. Remove the bearing from the shaft using a thrust extractor and taking care not to damage the shaft.

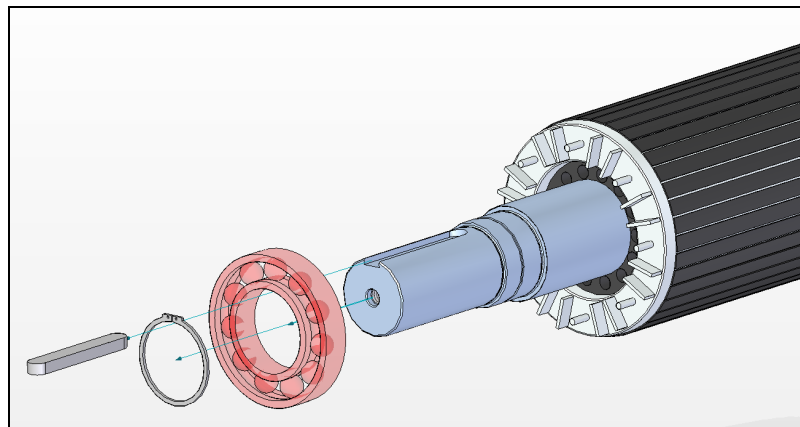

Figure 18: Replacing bearings on MAC-Q motors (steps 6 and 7)

8. Heat the new bearing to 70°C to make it dilate and easier to insert in the shaft.
9. Insert the new bearing in the shaft. The hot bearing must be inserted fully without the need for hitting it. This operation must be performed as quickly as possible. Do not let the bearing cool down.
10. Reassembled the *Seeger* shim washers.
11. Re-insert the rotor in the stator, taking care not to damage the windings.
12. Fit and screw up the covers and seals.
13. Refit the motor accessories.



6.3 Replacing the encoder

The procedure for replacing the encoder must be carried out as follows, depending on the type:

6.3.1 Solid shaft encoder

1. Remove the protection (a)
2. Loosen the elastic coupling (b) that connects the shafts
3. Remove the stator flange (c)
4. Remove the encoder (d) from the flange

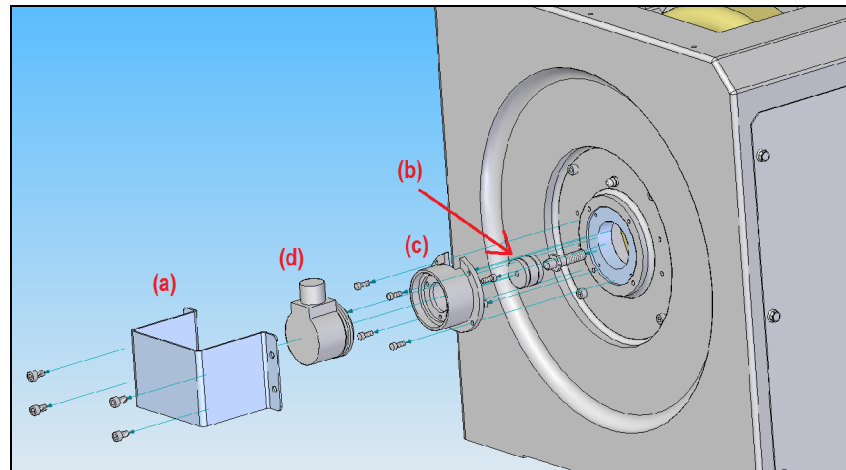

Figure 19: Replacing the encoder on MAC-Q motors (solid shaft type)

6.3.2 Hollow blind shaft encoder

1. Remove the protection (a)
2. Remove the encoder (b)

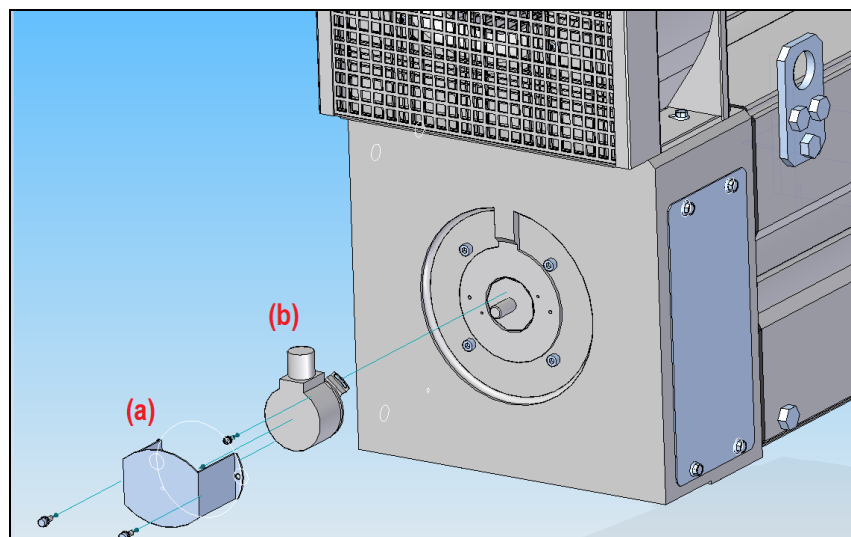

Figure 20: Replacing the encoder on MAC-Q motors (hollow blind shaft type)



6.4 Replacing the brake and/or lining

The procedure for replacing the brake must be carried out as follows:

1. Remove the entire stator from the brake (a)
2. Then remove the protection ring (c)
3. Remove the rotor (b) by sliding it through the bushing that remains coupled to the shaft by a Seeger ring.
4. If the rotor lining is worn, replace it with a new one.

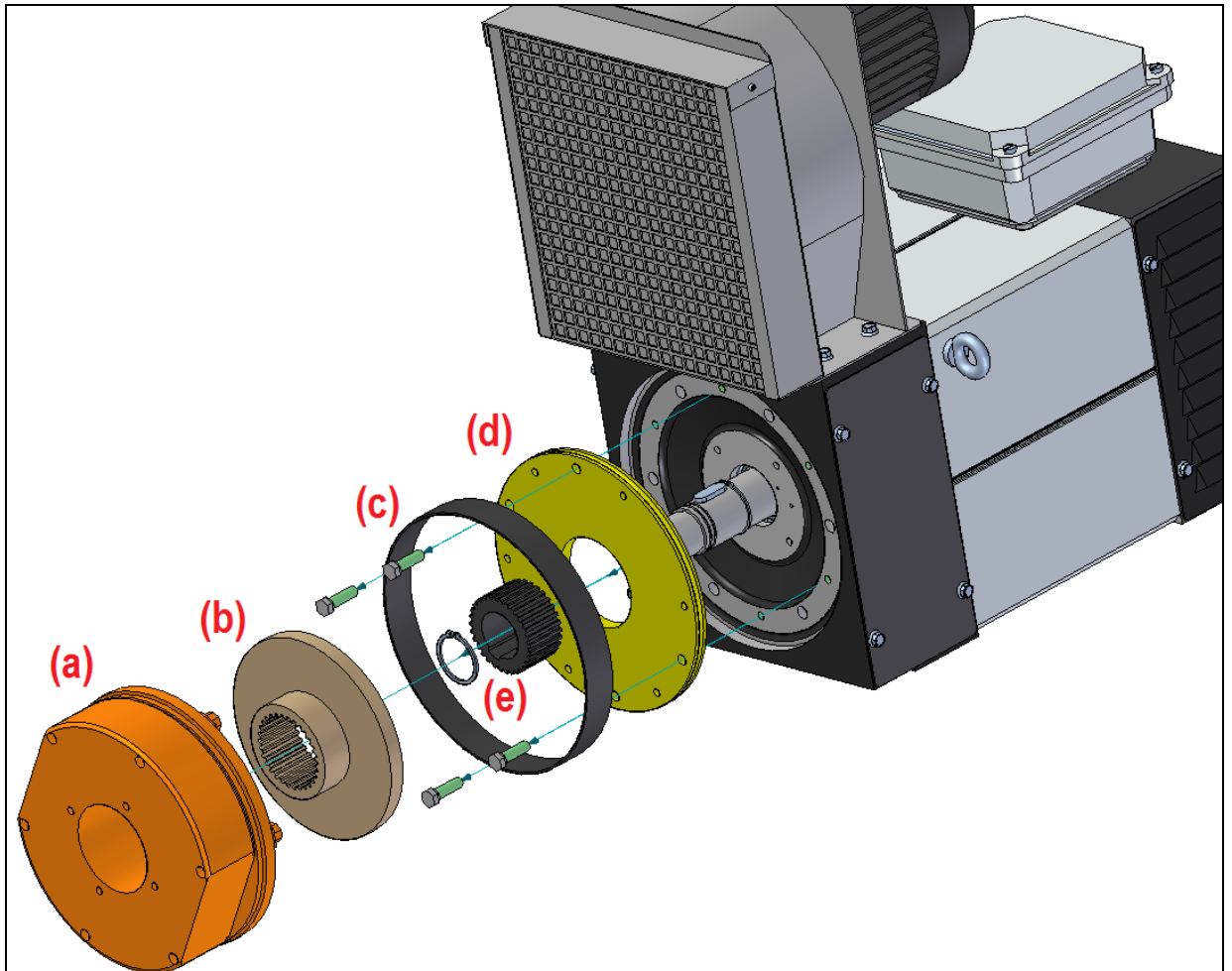

Figure 21: Replacing the brake on MAC-Q motors



6.5 Original spares

VASCAT supplies subunits of the complete motor as original spares for MAC Q motors.

The spare subunits that are available are listed in the table below:

Spares	Subunits
1	<i>Stator subunit</i>
2	<i>Rotor subunit</i>
3	<i>DE End-shield</i>
4	<i>NDE End-shield</i>
5	<i>Terminal box</i>
6	<i>Fan</i>
7	<i>Protections kit</i>

Table 24: Spare subunits

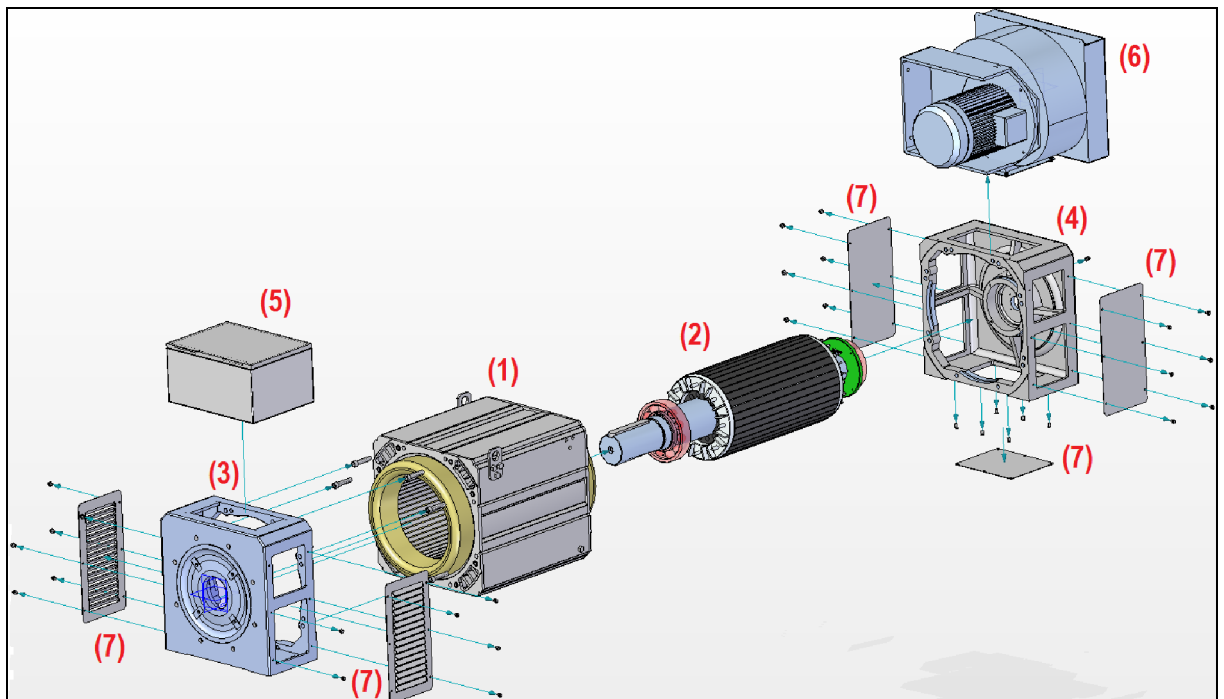

Figure 22: Spare subunits



When a specific original spare is required for a motor from the MAC QI, QE, QX series, the following information must be provided:

1. Motor type (by default, MAC).
2. Series (QI, QE or QX).
3. Size (in reference to shaft height).
4. Length (K, S, M, L, P or X).

These initial 4 points refer to the name of the motor and are summarised in the following table:

<i>MAC</i>	<i>QI</i>	<i>200</i>	<i>M</i>
<i>Motor type</i>	<i>Series</i>	<i>Size</i>	<i>Length</i>

Table 25: MAC-Q motor codes

Besides the initial 4 points, the following must also be specified:

5. Motor serial number.
6. Year of manufacturing.

All the information can be found on the motor nameplate.



6.6 Operating faults

If faults appear during the operation of the motor, first of all check the possibility of the errors given in the following tables. If the fault cannot be eliminated with any of the following measures, please contact the technical service at VASCAT.

	VOLTAGE
All the work must be carried out with no voltage connected.	

	HOT SURFACE
Hot motor surfaces. Therefore, cooling times must be observed.	

6.6.1 Electrical faults

Fault	Probable cause	Corrective action
Motor doesn't start	Excessive load	Reduce load
	Power connection problems	Check the frequency converter, power cables and phase sequence.
	Problems with encoder connections	Check encoder cables and converter alarms
	Converter disabled	Check message on converter
Motor starts up with difficulty	Excessive load	Reduce load
	Power connection problems	Check the frequency converter, power cables and phase sequence.
	Short-circuit between turns or phase short-circuit on stator winding.	Check the elements of each winding phase (milliohmmer) and the insulation elements (between phases and between phases and earth using a megaohmmeter at 250 V). Repair the winding after consulting VASCAT.
Incorrect motor rotation direction.	Change of motor power cable polarity	Swap two motor connection phases
Buzzing noise on start-up	Interruption of a phase in the power cable after connection	Check the frequency converter and power cables
	Short-circuit between turns or phase short-circuit on stator winding.	Check the elements of each winding phase (milliohmmer) and the insulation elements (between phases and between phases and earth using a megaohmmeter at 250 V). Repair the winding after consulting VASCAT.
Buzzing noise during operation	Overload	Reduce load
	Interruption of a phase in the power cable after connection	Check the frequency converter and power cables
	Short-circuit between turns or phase short-circuit on stator winding.	Check the elements of each winding phase (milliohmmer) and the insulation elements (between phases and between phases and earth using a megaohmmeter at 250 V). Repair the winding after consulting VASCAT.

Table 26: Electrical faults (1)



Fault	Probable cause	Corrective action
Overheating during load-free operation	Converter output voltage too high, frequency too low	Check adjustments on frequency converter and perform auto-tuning
	Motor designed to be connected in star format but is connected in triangle format	Correct connection in terminal box
	Fans stopped or turning in opposite direction	Connect fan. Invert phase sequence in case of inverse rotation.
	Fan broken down or airflow insufficient due to blocked channels	Repair fan or clean filter
	Cooling air is preheated	Ensure the entry of fresh air
Overheating with load	Excessive load	Reduce load
	Converter output voltage too high, frequency too low	Check adjustments on frequency converter and perform auto-tuning
	Power connection problems	Check the frequency converters and power cables
	Motor designed to be connected in star format but is collected in triangle format	Correct connection
	Fan stopped	Connect fan
	Fan broken down or airflow insufficient due to blocked channels	Repair fan or clean filter
	Cooling air is preheated	Ensure the entry of fresh air
Overheating on certain winding sections	Short-circuit between turns or phase short-circuit on stator winding.	Determine the winding elements and insulation elements. Repair them after checking with manufacturer

Table 27: Electrical faults (2)

NB: Because the machine is powered from a frequency converter, please also check the frequency converter operation manual in the event of electrical faults.



6.6.2 Mechanical faults

Fault	Probable cause	Corrective action
Rubbing noise	Rotating parts are rubbing together	Determine the cause and readjust the parts
	Foreign bodies in the motor	If so, repair by manufacturer
	Damage to bearings	Change bearings
Excessive radial vibrations	Rotor imbalance	Uncouple rotor and rebalance it
	Non-concentric rotor, shaft bent	Contact factory
	Non-concurrent shaft alignment	Align motor-machine system.
	Imbalance on coupled machine	Rebalance coupled machine
	Vibrations transmitted by the gearbox	Ensure the gearbox fitting
	Resonance from foundations	Reinforce foundations after checking with factory
	Changes to foundations	Determine cause and eliminate it. Realign machine
Excessive axial vibrations	Faulty angular alignment	Align group of machines and check alignment
	Blows transmitted by coupled machine	Examine coupled machine
	Vibrations transmitted by the gearbox	Ensure the gearbox fitting
	Resonance from foundations	Reinforce foundations after checking with factory
	Changes to foundations	Determine cause and eliminate it. Realign machine

Table 28: Mechanical faults



6.7 Technical support and service

For more information or specific technical support, please contact:

VASCAT, S.A.

P.I. Mas les Vinyes, C/ De l'Esquirol, s/n
Apartado 142
08570 Torelló (Barcelona)

Tel. +34 93 850 49 38
Fax: +34 93 859 31 31

www.vascat.es
vascat@vascat.es

CTT 02 – ED 03



Zona Industrial Pont de les Vinyes

C/ del Esquirol, s/n

08570 Torelló (Barcelona) SPAIN

Tel. +34 938 504 938 • Fax +34 938 593 131

www.vascat.com • vascat@vascat.es