



MOTOR MAC QI 132 X

- Hoja de Datos Técnicos -
- Technical Datasheet -

Código DT-QI132X
Edición 13
Página 1/2
Fecha 24/03/2015

Ventilador / Fan		Rodamientos Delantero 6310 ZZ C3		Trasero 6208 ZZ C3	
Tipo de Refrigeración IC 06		Bearings Drive End		Non Drive End	
Cooling Mode		Nº de polos 4		Momento de inercia $J = 0,114 \text{ Kg m}^2$	
Alimentación / Supply 400V 50Hz		Rotor Inertia		Peso Motor 175 Kg	
Potencia / Power 0,37 KW		Protección IP 23		Construcción IM B3 / B35	
Corriente / Current 1,11A		Protection Degree		Equilibrado grado A	
Velocidad / Speed 2800 rpm		Nivel de ruido < 80 dB		Velocidad máxima mecánica 6000 rpm	
Caudal / Air flow 900 m3/h		Noise Level		Max. Mechanical Speed	
Presión / Pressure 680 Pa		Aislamiento Clase F		Protección Térmica PTC 140 °C	
Por favor, indicar en los pedidos la alimentación deseada para el ventilador / Please indicate the required fan supply voltage when placing your order		Insulation Class		Ambiente < 40 °C < 1000 m	
		Normas de referencia EN60034		Comutación Variador 4 kHz ; du/dt TS60034-25 Type B	
Freno de Bloqueo (opcional)		150 Nm		24 Vdc 3,5 A 85 W 12 Kg $J = 0.0029 \text{ Kg m}^2$	
Holding Brake (optional)					
Tensión de Base del Motor Vb 400 V		Tensión Máxima de Salida del Convertidor Vc 400 V			
Motor Base Voltage		Inverter max. Output Voltage			

Bobinado Winding	Servicio / Service S1						Servicio / Service S6 - 40%						Corriente en vacío No Load Current (A)
	Nm	A	KW	rpm	Hz	Velocidad a Pot. Cte Const. Power Speed. (rpm)	Nm	A	KW	rpm	Hz	Velocidad a Pot. Cte Const. Power Speed. (rpm)	
111	270	22.9	9.2	326	12	740	400	32.2	13.6	326	13	540	9.8
211	270	29.3	13.0	461	17	1060	400	41.1	19.3	461	17	780	12.8
112	270	37.5	17.7	625	22	1430	400	52.5	26.1	625	23	1050	16.5
121	270	43.1	21.1	745	26	1710	400	60.8	31.2	745	27	1260	17.9
212	270	49.3	24.4	865	30	1980	400	69.2	36.2	865	31	1460	21.2
221	270	57.2	28.7	1015	35	2330	400	80.4	42.5	1015	36	1720	24.4
122	270	74.0	38.0	1345	46	3090	400	103.9	56.3	1345	47	2280	31.9
141	270	85.4	43.9	1555	53	3570	400	119.7	65.1	1555	54	2640	37.2
222	270	99.2	50.8	1796	61	4130	399	138.0	75.0	1796	62	3050	45.5
241	270	113.9	59.2	2095	71	4810	400	159.5	87.6	2095	72	3550	50.0
142	270	148.0	77.9	2755	93	6000	400	207.3	115.2	2755	94	4660	64.9

Otras Velocidades disponibles bajo consulta a nuestra O.T. / Other speeds available on request

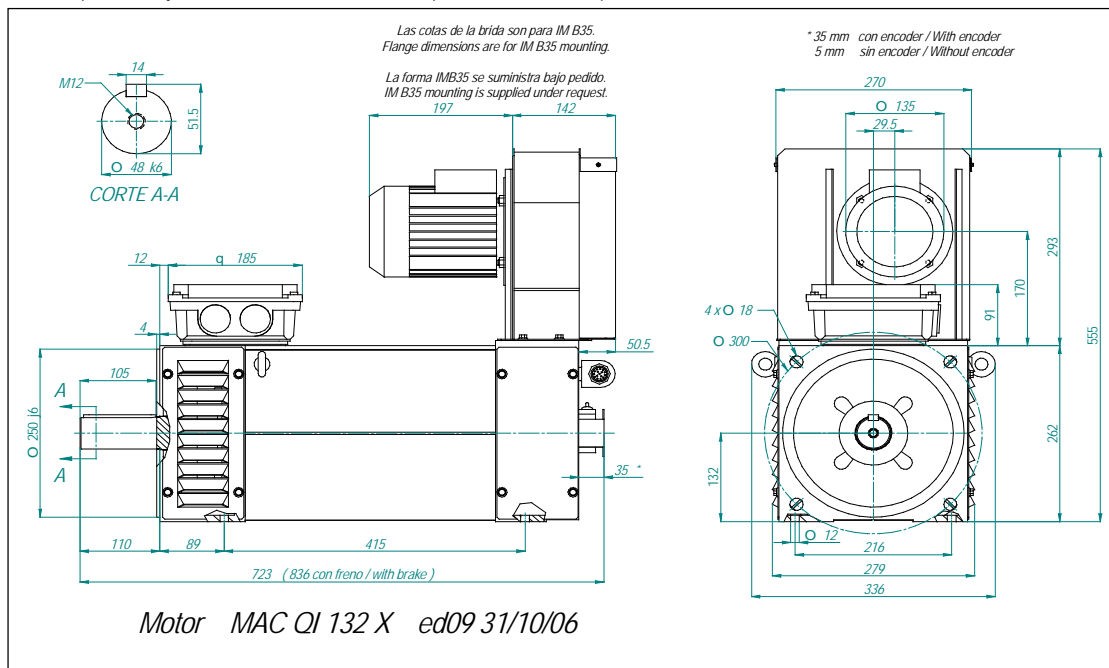

Datos técnicos sujetos a modificaciones sin previo aviso / Technical Data are subject to changes without prior notice

Elabora:	Revisa:	Aprueba:
----------	---------	----------

