

Frequency Inverter

CFW-11

User's Manual

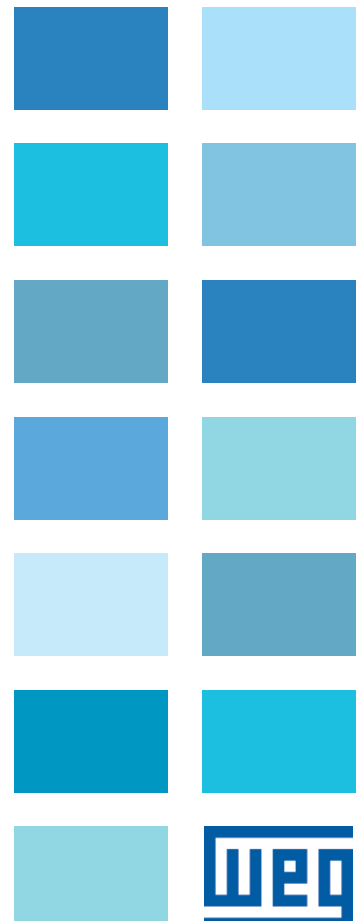

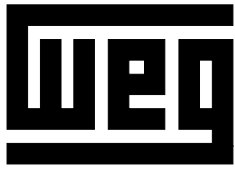

CFW-11 VECTRUE INVERTER

FREQUENCY INVERTER MANUAL

Series: CFW-11

Language: English

Document: 10000784107 / 08

Models: 242...1141 A / 380...480 V

Models with Special DC Hardware:
242...1141 A / 380...480 V

Summary of Revisions

The information below describes the revisions made in this manual.

Version	Revision	Description
-	R01	First edition
-	R02	Correction of Table 8.1 on page 8-2
-	R03	General revision
-	R04	It was added: The Safety Stop function Modifications of Slot 4 and Slot 5 New accessory models New models of recommended fuses Inclusion of frame size H General revision
-	R05	General revision
-	R06	Table 3.2 on page 3-13 and Figure 8.1 on page 8-4 updated Item 3.2.2 Power/Grounding Wiring and Fuses on page 3-12 and Section 3.3 SAFETY STOP FUNCTION on page 3-38 updated General revision
-	R07	General revision
-	R08	Figure 2.1 on page 2-7 and Figure 2.2 on page 2-8 updated

1 SAFETY INSTRUCTIONS	1-1
1.1 SAFETY WARNINGS IN THE MANUAL.....	1-1
1.2 SAFETY WARNINGS IN THE PRODUCT.....	1-1
1.3 PRELIMINARY RECOMMENDATIONS	1-2
2 GENERAL INFORMATION	2-1
2.1 ABOUT THE MANUAL	2-1
2.2 TERMS AND DEFINITIONS USED IN THE MANUAL	2-2
2.3 ABOUT THE CFW-11	2-5
2.4 CFW-11 IDENTIFICATION LABELS.....	2-12
2.5 HOW TO SPECIFY THE CFW-11 MODEL (SMART CODE).....	2-14
2.6 RECEIVING AND STORAGE.....	2-15
3 INSTALLATION AND CONNECTION	3-1
3.1 MECHANICAL INSTALLATION	3-1
3.1.1 Environmental Conditions	3-1
3.1.2 Positioning and Mounting	3-2
3.1.3 Cabinet Mounting	3-5
3.1.4 Access to the Control and Power Terminals	3-6
3.1.5 HMI Installation at the Cabinet Door or Command Panel (Remote HMI)	3-7
3.2 ELECTRICAL INSTALLATION	3-8
3.2.1 Identification of the Power and Grounding Terminals.....	3-8
3.2.2 Power/Grounding Wiring and Fuses	3-12
3.2.3 Power Connections.....	3-19
3.2.3.1 Input Connections	3-22
3.2.3.1.1 Power Supply Capacity	3-23
3.2.3.1.2 IT Networks	3-23
3.2.3.1.3 Command Fuses of Pre-charge Circuit.....	3-24
3.2.3.2 Dynamic Braking	3-24
3.2.3.3 Output Connections.....	3-26
3.2.4 Grounding Connections	3-28
3.2.5 Control Connections.....	3-30
3.2.6 Typical Control Connections	3-35
3.3 SAFETY STOP FUNCTION	3-38
3.4 INSTALLATION ACCORDING TO THE EUROPEAN DIRECTIVE OF ELECTROMAGNETIC COMPATIBILITY	3-38
3.4.1 Conformal Installation	3-39
3.4.2 Standard Definitions	3-39
3.4.3 Emission and Immunity Levels.....	3-40

4 HMI	4-1
4.1 INTEGRAL KEYPAD - HMI-CFW-11	4-1
4.2 PARAMETER STRUCTURE	4-4
5 FIRST TIME POWER-UP AND START-UP	5-1
5.1 START-UP PREPARATION	5-1
5.2 START-UP	5-2
5.2.1 P0000 Password Setting	5-3
5.2.2 Oriented Start-Up.....	5-3
5.2.3 Basic Application Parameter Settings.....	5-5
5.3 DATE AND TIME SETTING	5-9
5.4 BLOCKING PARAMETERS MODIFICATION.....	5-10
5.5 HOW TO CONNECT A PC.....	5-10
5.6 FLASH MEMORY MODULE.....	5-11
6 TROUBLESHOOTING AND MAINTENANCE	6-1
6.1 OPERATION OF FAULTS AND ALARMS.....	6-1
6.2 FAULTS, ALARMS, AND POSSIBLE CAUSES	6-2
6.3 SOLUTIONS FOR THE MOST FREQUENT PROBLEMS	6-8
6.4 INFORMATION NECESSARY FOR CONTACTING TECHNICAL SUPPORT	6-8
6.5 PREVENTIVE MAINTENANCE	6-9
6.5.1 Cleaning Instructions	6-10
7 OPTION KITS AND ACCESSORIES	7-1
7.1 OPTION KITS	7-1
7.1.1 Safety Stop Function.....	7-1
7.1.2 24 Vdc External Control Power Supply	7-1
7.2 ACCESSORIES	7-2
7.2.1 Use of External Dynamic Braking Module DBW03 and DBW04	7-4
7.2.1 Use of External Dynamic Braking Module DBW03 and DBW04	7-4
8 TECHNICAL SPECIFICATIONS	8-1
8.1 POWER DATA.....	8-1
8.2 ELECTRONICS/GENERAL DATA	8-6
8.3 CODES AND STANDARDS	8-7
8.4 CERTIFICATIONS.....	8-7
8.5 MECHANICAL DATA.....	8-8

1 SAFETY INSTRUCTIONS

This manual provides information for the proper installation and operation of the CFW-11 frequency inverter.

Only trained and qualified personnel should attempt to install, start-up, and troubleshoot this type of equipment.





1.1 SAFETY WARNINGS IN THE MANUAL

The following safety warnings are used in this manual:

 **DANGER!**
The procedures recommended in this warning have the purpose of protecting the user against dead, serious injuries and considerable material damage.

 **DANGER!**
Les procédures concernées par cet avertissement sont destinées à protéger l'utilisateur contre des dangers mortels, des blessures et des détériorations matérielles importantes.

 **ATTENTION!**
The procedures recommended in this warning have the purpose of avoiding material damage.

 **NOTE!**
The text intends to supply important information for the correct understanding and good operation of the product.

1.2 SAFETY WARNINGS IN THE PRODUCT

The following symbols are attached to the product and require special attention:

 High voltages are present.

 Components sensitive to electrostatic discharge.
Do not touch them.

 Mandatory connection to the protective ground (PE).

 Connection of the shield to the ground.

 Hot surface.

1.3 PRELIMINARY RECOMMENDATIONS



DANGER!

Only qualified personnel familiar with the CFW-11 frequency inverter and associated equipment should plan or implement the installation, start-up and subsequent maintenance of this equipment. These personnel must follow all the safety instructions included in this manual and/or defined by local regulations.

Failure to comply with these instructions may result in death, serious injury, and equipment damage.



DANGER!

Seulement personnes avec la qualification adéquate et familiarisation avec le CFW-11 et équipements associés doivent planifier ou implémenter l'installation, mise en marche, operation et entretien de cet équipement.

Cettes personnes doivent suivre toutes les instructions de sécurités indiquées dans ce manuel, et/ou définies par normes locales.

L'inobservance des instructions de sécurité peut résulter en risque de vie et/ou dommages de cet équipement.



NOTE!

For the purposes of this manual, qualified personnel are those trained and able to:

1. Install, ground, power-up and operate the CFW-11 according to this manual and the effective legal safety procedures.
2. Use protection equipment according to the established regulations.
3. Provide first aid.



DANGER!

Always disconnect the main power supply before touching any electrical component associated to the inverter.

Several components can remain charged with high voltages or remain in movement (fans) even after the AC power is disconnected or switched off.

Wait for at least ten minutes so as to ensure the full discharge of the capacitors.

Always connect the equipment frame to the protection earth (PE) at the suitable connection point.



DANGER!

Débranchez toujours l'alimentation principale avant d'entrer en contact avec un appareil électrique associé au variateur.

Plusieurs composants peuvent rester chargés à un potentiel électrique élevé et/ou être en mouvement (ventilateurs), même après la déconnexion ou la coupure de l'alimentation en courant alternatif.

Attendez au moins 10 minutes que les condensateurs se déchargent complètement.

Raccordez toujours la masse de l'appareil à une terre protectrice (PE).



ATTENTION!

Electronic boards have components sensitive to electrostatic discharges. Do not touch directly on components or connectors. If necessary, touch the grounded metallic frame before or use an adequate grounded wrist strap.

**Do not perform any withstand voltage test (hi-pot test)!
If necessary, consult WEG.**

**NOTE!**

Frequency inverter may interfere with other electronic equipment. In order to reduce these effects, take the precautions recommended in the [Chapter 3 INSTALLATION AND CONNECTION](#) on page 3-1.

**NOTE!**

Read the user manual completely before installing or operating the inverter.

**DANGER!****Crushing hazard**

In order to ensure safety in load lifting applications, electric and/or mechanical devices must be installed outside the inverter for protection against accidental fall of load.

**DANGER!**

This product was not designed to be used as a safety element. Additional measures must be taken so as to avoid material and personal damages.

The product was manufactured under strict quality control, however, if installed in systems where its failure causes risks of material or personal damages, additional external safety devices must ensure a safety condition in case of a product failure, preventing accidents.

**DANGER!****Risque d'écrasement**

Afin d'assurer la sécurité dans les applications de levage de charges, les équipements électriques et/ou mécaniques doivent être installés hors du variateur pour éviter une chute accidentelle des charges.

**DANGER!**

Ce produit n'est pas conçu pour être utilisé comme un élément de sécurité. Des précautions supplémentaires doivent être prises afin d'éviter des dommages matériels ou corporels.

Ce produit a été fabriqué sous un contrôle de qualité conséquent, mais s'il est installé sur des systèmes où son dysfonctionnement entraîne des risques de dommages matériels ou corporels, alors des dispositifs de sécurité externes supplémentaires doivent assurer des conditions de sécurité en cas de défaillance du produit, afin d'éviter des accidents.

**ATTENTION!**

When in operation, electric energy systems – such as transformers, converters, motors and cables – generate electromagnetic fields (EMF), posing a risk to people with pacemakers or implants who stay in close proximity to them. Therefore, those people must stay at least 2 meters away from such equipment.

2 GENERAL INFORMATION

2.1 ABOUT THE MANUAL

This manual exposes how to install, to start-up in V/f (scalar) mode, the main characteristics and shows how to troubleshoot the most common problems of the CFW-11 inverter series frame sizes F, G and H models.

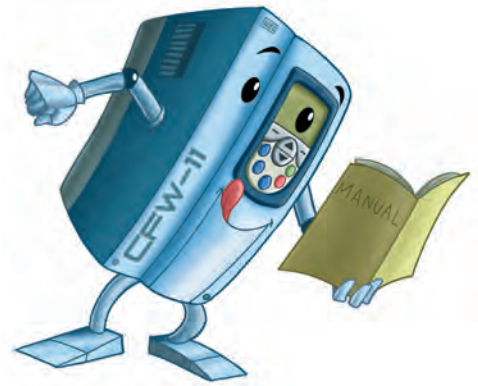

It is also possible to operate the CFW-11 in VVW, Sensorless Vector and Vector with Encoder modes. For more details on the start-up in the other control modes, refer to the programming manual.



ATTENTION!

The operation of this equipment requires installation instructions and detailed operation provided in the user manual, programming manual and manuals/guides for kits and accessories.

The user's manual and the parameters quick reference are supplied in a hard copy together with the inverter.

The user guides are also provided in a hard copy along with the kit/accessories.

The other manuals are available at www.weg.net.

A printed copy of the files available on WEG's website can be requested at your local WEG dealer.

For information on other functions, accessories and operation conditions, consult the following manuals:

- ☑ Programming manual, with a detailed description of the CFW-11 parameters and advanced functions.
- ☑ Incremental Encoder Interface module manual.
- ☑ I/O Expansion module manual.
- ☑ RS-232/RS-485 serial communication manual.
- ☑ CANopen Slave communication manual.
- ☑ Anybus-CC communication manual.
- ☑ Manual of DeviceNet communication.
- ☑ Manual of Ethercat communication.
- ☑ Manual of Profibus communication.
- ☑ Manual of Symbinet communication.
- ☑ Manual of the SoftPLC.

These manuals available at site www.weg.net.

2.2 TERMS AND DEFINITIONS USED IN THE MANUAL

Normal Duty Cycle (ND): inverter duty that defines the maximum current values for continuous duty I_{nom-ND} and an overload of 110 % during 1 minute. It is selected by programming P0298 (Application) = 0 (Normal Duty (ND)). It must be used for driving motors that are not subject in that application to high torques with respect to their rated torque, when operating at constant speed, during start, acceleration or deceleration.

I_{nom-ND} : inverter rated current for use with normal duty cycle (ND = Normal Duty).
Overload: $1,1 \times I_{nom-ND} / 1 \text{ minute}$.

Heavy Duty Cycle (HD): inverter duty that defines the maximum current values for continuous duty I_{nom-HD} and an overload of 150 % during 1 minute. It is selected by programming P0298 (Application) = 1 (Heavy Duty – HD). It must be used for driving motors that are subject in that application to high torques with respect to their rated torque, when operating at constant speed, during start, acceleration or deceleration.

I_{nom-HD} : inverter rated current for use with heavy duty cycle (HD = Heavy Duty).
Overload: $1,5 \times I_{nom-HD} / 1 \text{ minute}$.

Rectifier: the input circuit of the inverters that converts the input AC voltage into DC, it is made of thyristors and power diodes.

Pre-charge circuit: it charges the DC link capacitors with a limited current, thus avoiding higher current peaks when powering the inverter.

DC Link: inverter intermediate circuit; DC voltage obtained from the rectification of the AC input voltage or from an external power supply. It feeds the inverter output IGBT bridge.

U, V and W Arms: set of two IGBTs forming the inverter output phases U, V and W.

IGBT: "Insulated Gate Bipolar Transistor"; it is the output inverter bridge basic component, working as an electronic switch either in the saturated (closed switch) or in the cut off mode (open switch).

Braking IGBT: it works as a switch to activate the braking resistances; it is controlled by the voltage level on the DC link.

Gate Driver: circuit used turn the IGBTs on and off.

PWM: "Pulse Width Modulation". A pulsed voltage that feeds the motor.

Switching Frequency: switching frequency of the IGBTs of the inverter bridge, normally expressed in kHz. Also known as carrier frequency.

Heatsink: it is a metal part designed for dissipating the heat generated by the power semiconductors.

PE: Protective Ground.

Varistor: Metal Oxide Varistor.

RFI Filter: "Radio Frequency Interference filter". A filter that avoids interference in the radiofrequency range.

PTC: it is a resistor, whose resistance value in ohms increases proportionally to the temperature increase, being used as temperature sensor in motors.

NTC: it is a resistor, whose resistance value in ohms decreases proportionally to the temperature increase, being used as temperature sensor in power modules.



HMI: "Human-Machine Interface" it is the device that allows the control of the motor, the visualization and the modification of the inverter parameters. The CFW-11 HMI presents keys for commanding the motor, navigation keys and a graphic LCD display.

Flash Memory: it is the nonvolatile memory that can be electrically written and erased.

RAM Memory: Random Access Memory (volatile).

USB: "Universal Serial Bus"; it is a serial bus standard that allows devices to be connected using the "Plug and Play" concept.

General Enable: when activated, it accelerates the motor via acceleration ramp. When deactivated, this function immediately blocks the PWM pulses. The general enable function can be controlled through a digital input programmed for this function or via serial communication.

Run/Stop: Inverter function that when activated (Run) accelerates the motor with the acceleration ramp until reaching the speed reference, and when deactivated (Stop) decelerates the motor with the deceleration ramp down to stop. It can be commanded through a digital input programmed for that function or via serial communication. The HMI keys  (Run) and  (Stop) work in a similar manner.

STO: safety function available as an option in the line of CFW-11 inverters.

When the STO function is enabled, the inverter ensures that no motion of the motor shaft will occur. It is also referred to as Safety Stop in the documentation of the CFW-11.

PLC: Programmable Logic Controller.

TBD: value to be defined.

AC: Alternating Current.

DC: Direct Current.

Amp, A: ampères.

°C: Celsius degree.

General Information

CFM: "Cubic feet per minute"; It is a flow measurement unit.

cm: centimeter.

°F: Fahrenheit degree.

Hz: hertz.

CV: "cheval-vapeur" = 736 Watts; Power measurement unit, normally used to indicate the mechanical power of electric motors.

ft: Foot.

hp: "Horse Power" = 746 Watts; Power measurement unit, normally used to indicate the mechanical power of electric motors.

in: Inch.

kg: Kilogram = 1000 grams.

kHz: Kilohertz = 1000 Hertz.

l/s: liters per second.

lb: pound.

m: meter.

mA: milliampère = 0.001 Ampère.

min: minute.

mm: millimeter.

ms: Millisecond = 0.001 seconds.

N.M.: Newton meter; torque measurement unit.

rms: "Root mean square"; Effective value.

rpm: "Revolutions per minute"; Speed measurement unit.

s: second.

V: volts.

Ω: ohms.

2.3 ABOUT THE CFW-11

The CFW-11 is a high performance variable frequency drive that makes it possible the control of speed and torque of three-phase AC induction motors. The central characteristic of this product is the "Vectrue" technology, which presents the following advantages:

- ☑ (V/f), V VV or vector control programmable in the same product.
- ☑ The vector control can be programmed as "sensorless" (which means standard motors, without the need of encoder) or vector control with motor encoder.
- ☑ The "sensorless" vector control allows high torque and fast response, even at very slow speeds or during starting.
- ☑ The "vector control with encoder" allows very high speed accuracy and control for the entire speed range (speed control down to 0 rpm).
- ☑ The "Optimal Braking" function for the vector control allows a controlled motor braking, eliminating in some applications the braking resistor.
- ☑ The vector control "Self-Tuning" function allows the automatic setting of the regulators and control parameters, from the identification (also automatic) of the motor and load parameters.

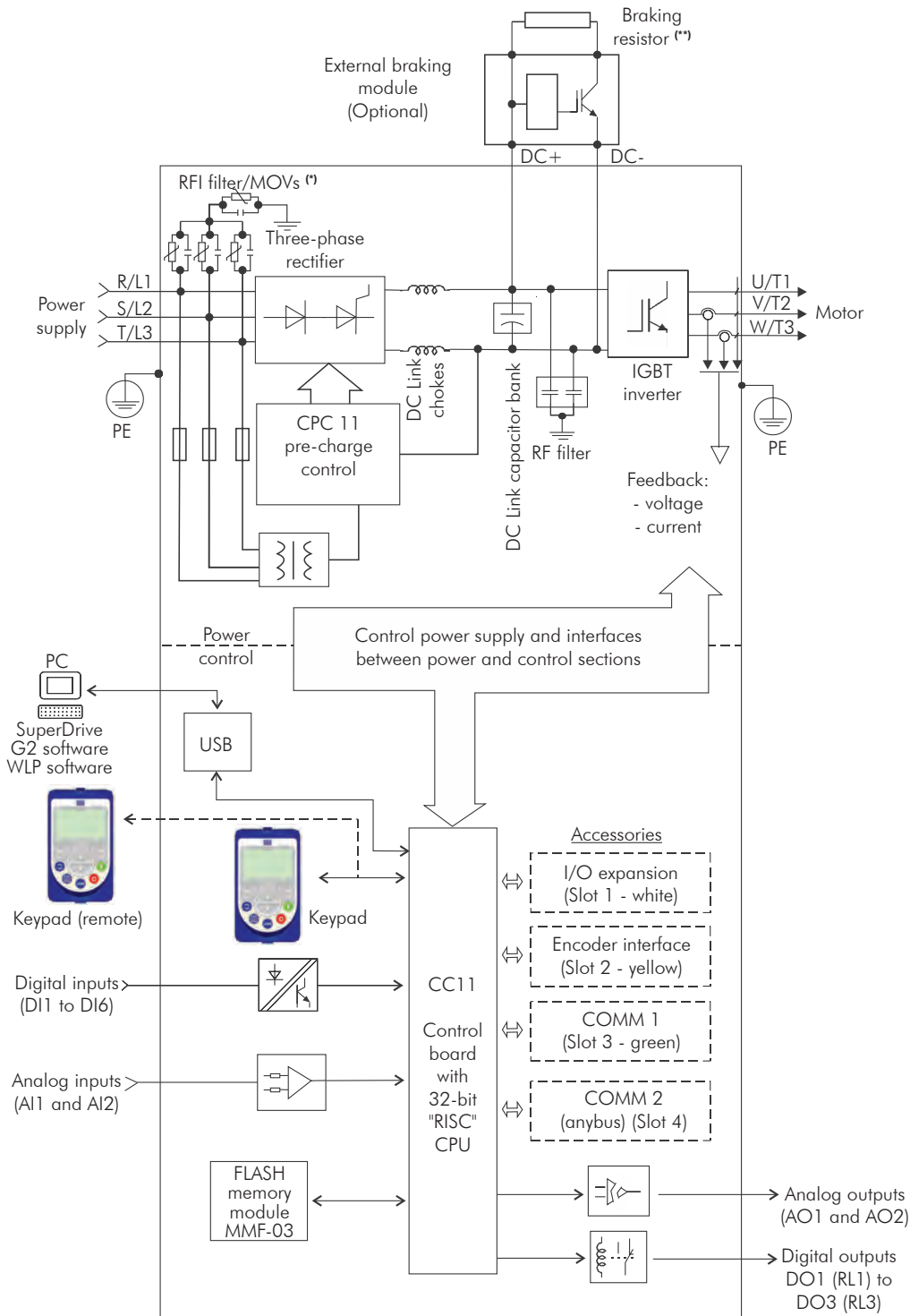

(*) The capacitor of RFI filter and MOV connected to the ground must be disconnected with IT network, high impedance grounding network and corner-grounded delta networks. Refer to [Item 3.2.3.1.2 IT Networks on page 3-23](#).
 (**) The terminals for DC connection can be used for DC power supply or for the connection of the braking module.

(a) Frame sizes F and G standard models with AC power supply

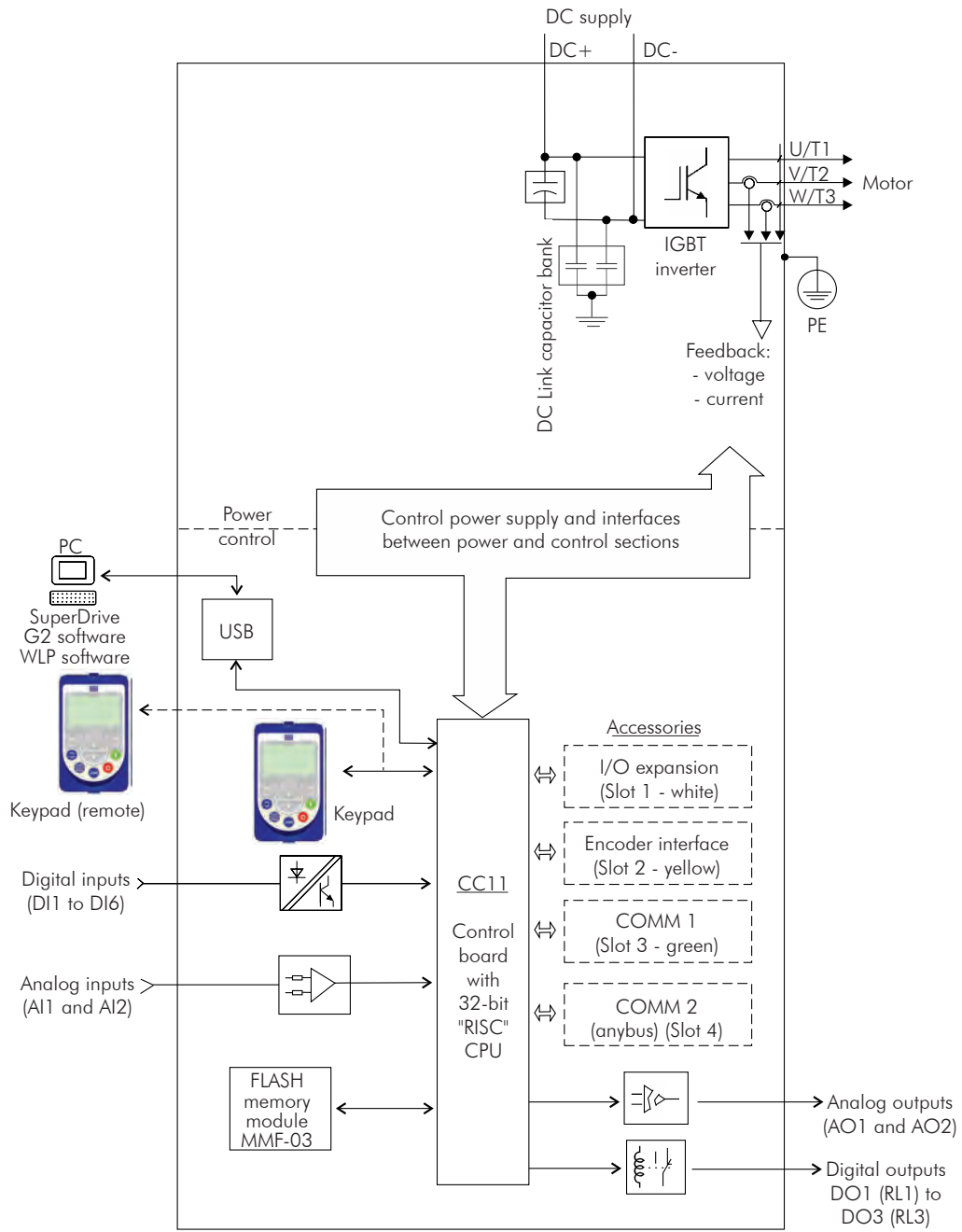

(b) Models with DC power supply (special DC hardware)

Figure 2.1 - (a) and (b) Block diagram for the CFW-11 - frame sizes F and G

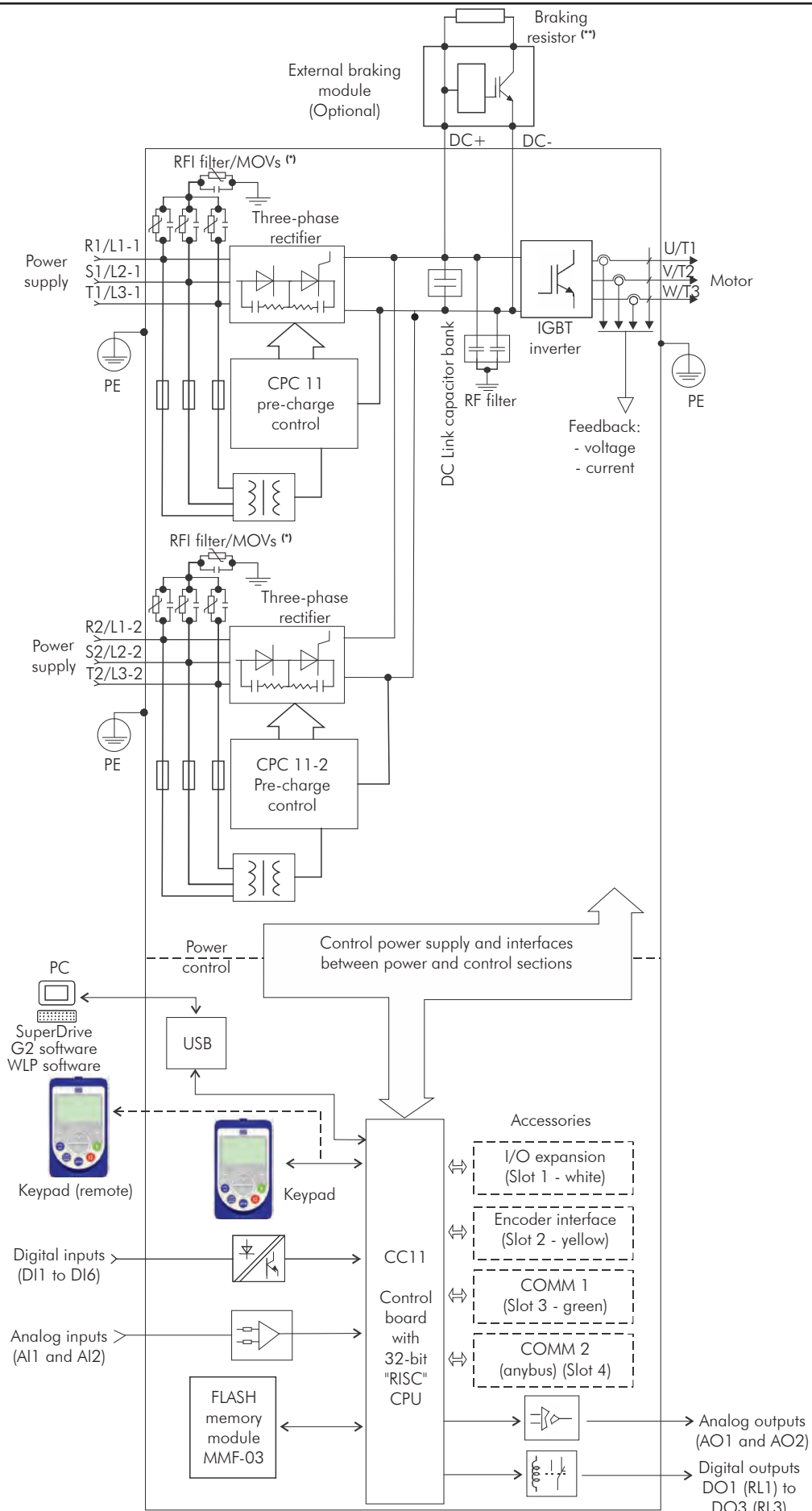

(*) The capacitor of RFI filter and MOV connected to the ground must be disconnected with IT network, high impedance grounding network and corner-grounded delta networks. Refer to [Item 3.2.3.1.2 IT Networks on page 3-23](#).
 (**) The terminals for DC connection can be used for DC power supply or for the connection of the braking module.

Figure 2.2 - Block diagram of CFW-11 standard models frame size H with AC current

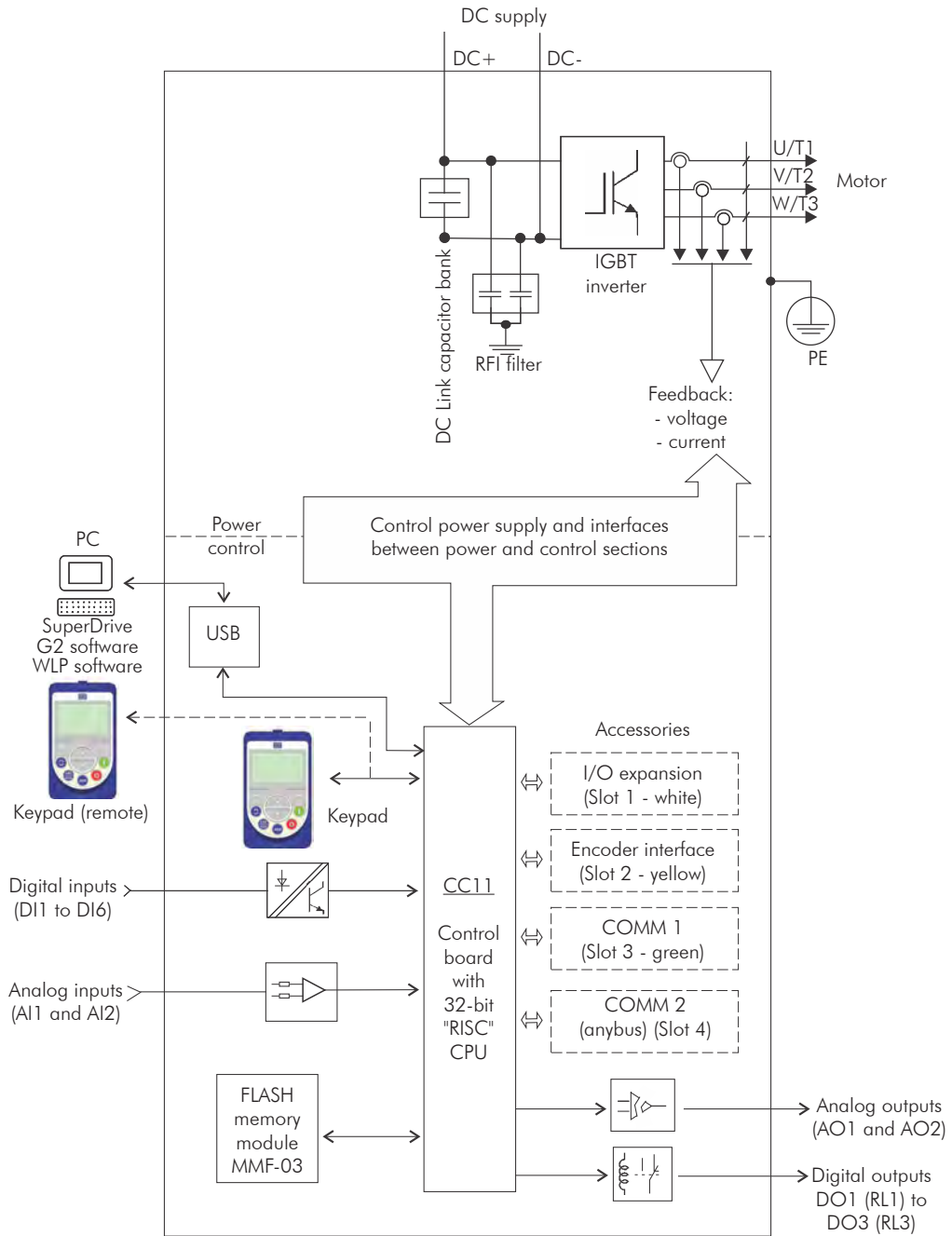
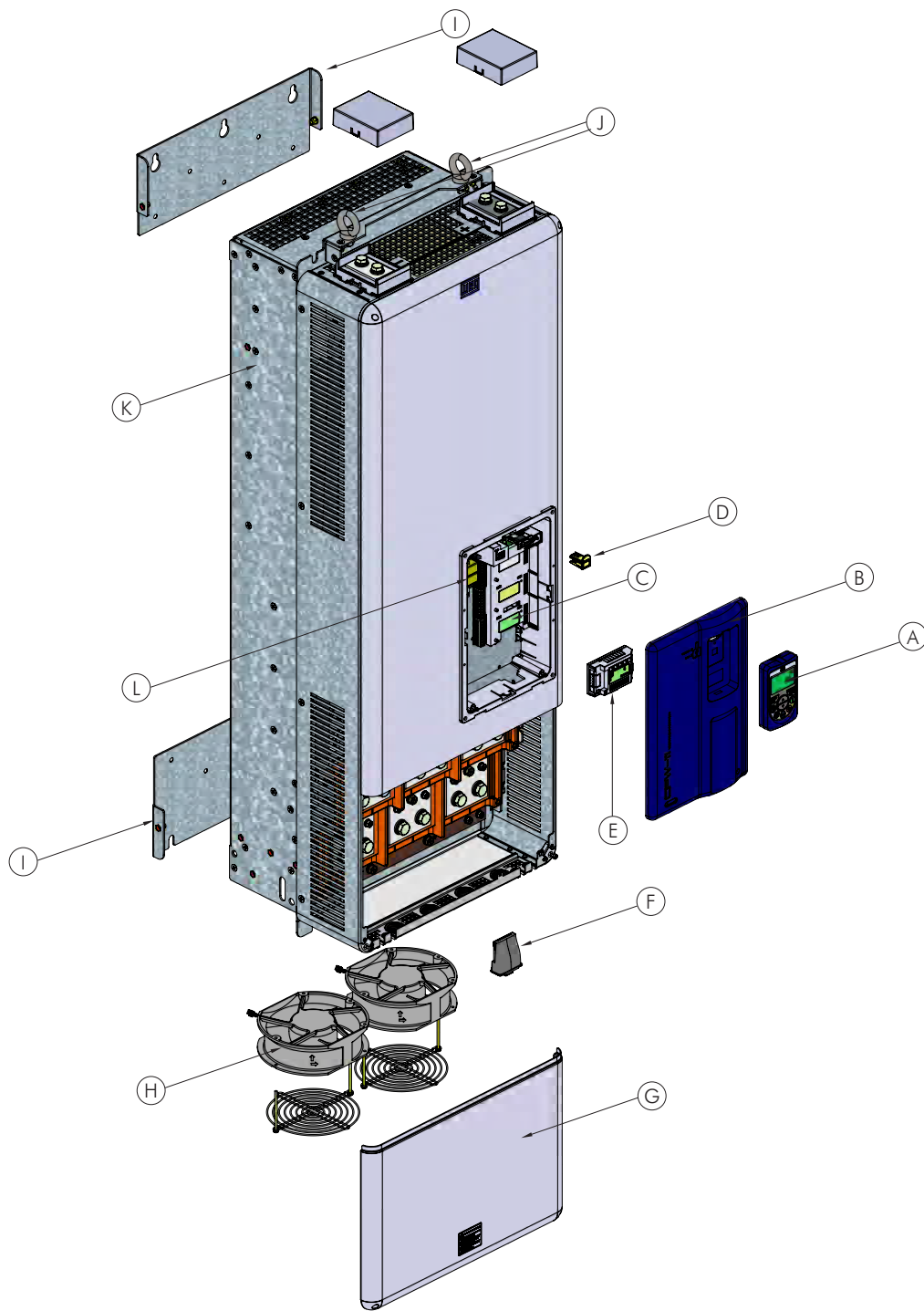
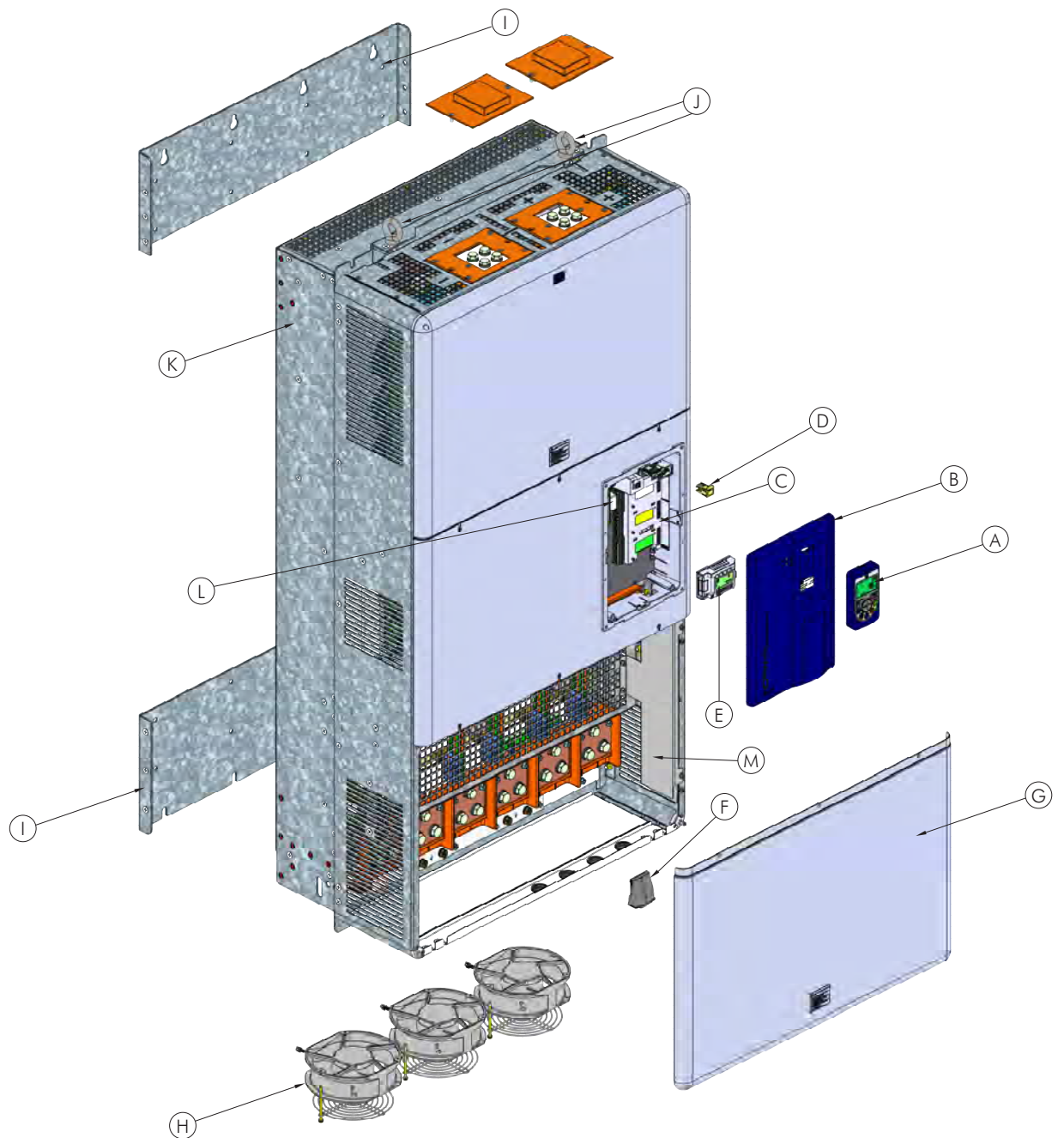

Figure 2.3 - Block diagram of CFW-11 standard models frame size H (special DC hardware)



- A - HMI
- B - control rack cover
- C - CC11 control board
- D - FLASH memory module MMF-03
- E - control accessory module
- F - Anybus-CC accessory module
- G - bottom front cover
- H - heatsink fan
- I - mounting supports (for surface mounting)
- J - hoisting eye
- K - rear part of the inverter (external part for flange mounting)
- L - SRB3 safety stop board

Figure 2.4 - CFW-11 main components - frame sizes F and G



- A - keypad
- B - control rack cover
- C - CC11 control board
- D - FLASH memory module MMF-03
- E - control accessory module
- F - Anybus-CC accessory module
- G - bottom front cover
- H - heatsink fan
- I - mounting supports (for surface mounting)
- J - hoisting eye
- K - rear part of the inverter (external part for flange mounting)
- L - SRB3 safety stop board
- M - shield for the control cables

Figure 2.5 - CFW-11 main components - frame size H

- ① USB connector
- ② USB LED
Off: without USB connection
On/blinking: USB communication active
- ③ Status LED
Green: normal operation without fault or alarm
Yellow: in the alarm condition
Blinking red: in the fault condition

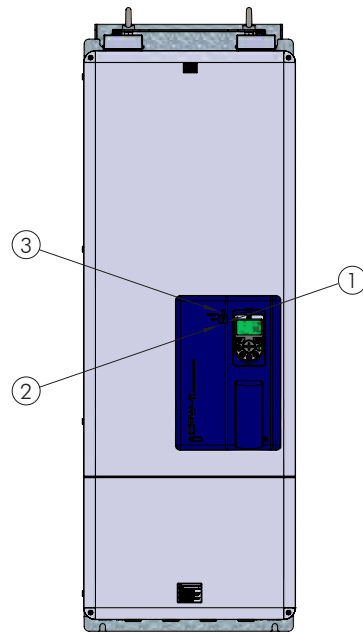

Figure 2.6 - LEDs and USB connector

2.4 CFW-11 IDENTIFICATION LABELS

There are two identification labels, one complete nameplate is affixed at the side of the inverter and a simplified label is located under the keypad. The label under the keypad allows the identification of the most important characteristics of the inverter even if they are mounted side-by-side.

CFW-11 model		WEG part number		Inverter net weight		Rated input data (voltage, number of power phases, rated currents for use with Normal Duty (ND) and Heavy Duty (HD) cycles, frequency)		Current specifications for use with the Normal Duty (ND) cycle		Current specifications for use with the Heavy Duty (HD) cycle		Maximum ambient temperature surrounding the inverter		Serial number		Manufacturing date (11 corresponds to the week and R to the year)		Rated output data (voltage, number of power phases, rated currents for use with Normal Duty (ND) and Heavy Duty (HD) cycles, overload currents for 1 min and 3 s, and frequency range)	
MOD: BRCFW110007T 40FAZ		MAT: 10234068		PESO/WEIGHT: 6,750 Kg		LINEA REDE		OUTPUT SAÍDA SAÍDA		FABRICATION NO BRASIL HECHO EN BRASIL MADE IN BRAZIL		380 - 480 V		0 - REDE		11 R		7 A	
OP: 123345678912		SERIAL#: 1133256589				3		3		UL LISTED IND. COMM. REG. 2009		7 A		7.7 A / 10.5 A		7 A		7 A	
						VAC		VAC		CE		5.5 A		5.5 A		5.5 A		5.5 A	
						A (ND) 60 s/3 s		A (ND) 60 s/3 s		EAC		5.5 A		8.25 A / 11 A		8.25 A / 11 A		8.25 A / 11 A	
						A (HD) 60 s/3 s		A (HD) 60 s/3 s		RAM		5.5 A		0-300 Hz		0-300 Hz		0-300 Hz	
						HZ		HZ		7894171075454		50 / 60 Hz		0-300 Hz		0-300 Hz		0-300 Hz	

(a) Nameplate affixed at the side of the inverter

CFW-11 model	BRCFW110007T 40FAZ	Manufacturing date (11 corresponds to week and R to year)
WEG part number	10234068	11R
	SERIAL#: 1133256589	Serial number

(b) Label located under the keypad

Figure 2.7 - (a) and (b) - Identification labels

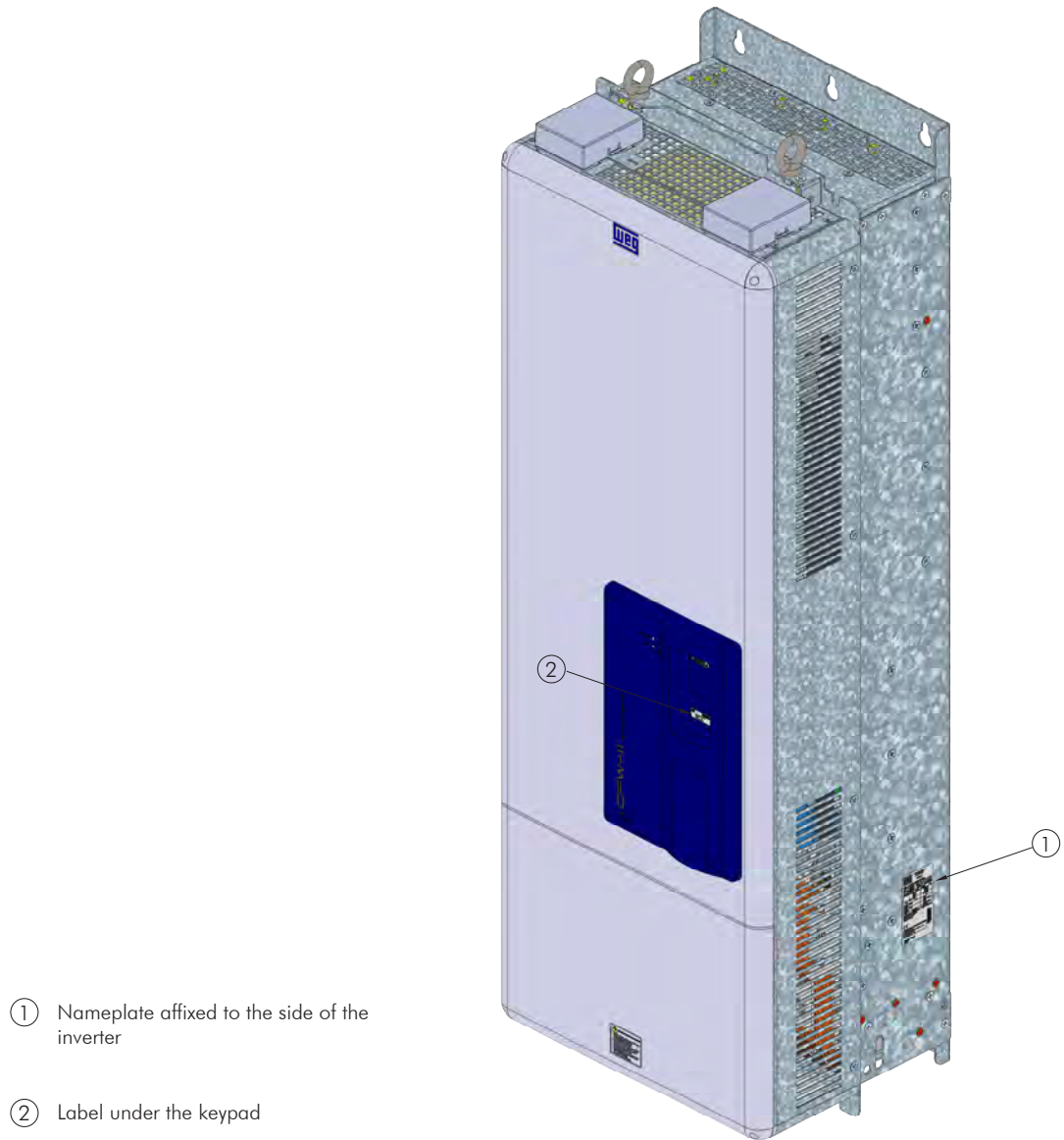

- ① Nameplate affixed to the side of the inverter
- ② Label under the keypad

Figure 2.8 - Location of the identification labels

2.5 HOW TO SPECIFY THE CFW-11 MODEL (SMART CODE)

		Inverter Model				Available Option Kits (installed in the product at the factory)									
Example	BR	CFW-11	0242	T	4	S	Enclosure protection degree	Keypad	Braking	RFI filter	Safety stop	External 24 Vdc control power supply	Special hardware	Special software	Z
Field description	Market identification (defines the manual language and the factory settings)	WEG CFW-11 frequency inverter series	Rated output current for use with the Normal Duty (ND) cycle	Number of power phases	Power supply voltage	Option kit									
Available options	2 characters		0242 = 211 A (HD) / 242 A (ND) 0312 = 242 A (HD) / 312 A (ND) 0370 = 312 A (HD) / 370 A (ND) 0477 = 370 A (HD) / 477 A (ND) 0515 = 477 A (HD) / 515 A (ND) 0601 = 515 A (HD) / 601 A (ND) 0720 = 560 A (HD) / 720 A (ND) 0760 = 600 A (HD) / 760 A (ND) 0795 = 637 A (HD) / 795 A (ND) 0877 = 715 A (HD) / 877 A (ND) 1062 = 855 A (HD) / 1062 A (ND) 1141 = 943 A (HD) / 1141 A (ND)	T = three-phase power supply	4 = 380...480 V	S = standard product O = product with option kit	Blank = standard (IP20) IP00 = Special hardware (DC)	Blank = standard keypad IC = no keypad (blind cover)	Blank = standard (no braking IGBT)	Blank = standard (with internal RFI filter)	Blank = standard (safety stop function is not available) Y = with safety stop function	Blank = standard (not available) W = with external 24 Vdc control power supply	Blank = standard DC = feeding with DC H1 = special hardware #1	Blank = standard S1 = special software nr. 1	Character that identifies the code end

Refer to Chapter 8 TECHNICAL SPECIFICATIONS on page 8-1 to check option kit availability for each inverter model

Inverter Model

Refer to the frame sizes F, G and H CFW-11 model list in the Chapter 8 TECHNICAL SPECIFICATIONS on page 8-1, where the technical specifications of the inverters are also presented

2.6 RECEIVING AND STORAGE

The CFW-11 inverters from the frame sizes F, G and H models are supplied packed in wooden boxes.

There is an identification label affixed to the outside of the package, identical to the one affixed to the side of the inverter CFW-11.

To open the package:

1. Remove the package front cover.
2. Take out the polystyrene foam protection.

Verify whether:

1. The CFW-11 nameplate corresponds to the purchased model.
2. Any damage occurred during transportation.

If any problems are detected, contact the carrier immediately.

If the CFW-11 is not installed soon, store it in a clean and dry location (temperature between $-25\text{ }^{\circ}\text{C}$ and $60\text{ }^{\circ}\text{C}$ ($-13\text{ }^{\circ}\text{F}$ and $140\text{ }^{\circ}\text{F}$)), with a cover to prevent dust accumulation inside it.



ATTENTION!

When the inverter is stored for a long period, it becomes necessary to perform the capacitor reforming. Refer to the procedure in the [Section 6.5 PREVENTIVE MAINTENANCE on page 6-9](#) on [Table 6.3 on page 6-9](#).

3 INSTALLATION AND CONNECTION

This chapter describes the CFW-11 electrical and mechanical installation procedures. The guidelines and suggestions must be followed aiming personnel and equipment safety, as well as the proper operation of the inverter.



3.1 MECHANICAL INSTALLATION

3.1.1 Environmental Conditions



NOTE!

The inverter is designed for indoor use only.

Avoid:

- ☑ Direct exposure to sunlight, rain, high humidity, or sea-air.
- ☑ Inflammable or corrosive gases or liquids.
- ☑ Excessive vibration.
- ☑ Dust, metallic particles, and oil mist.

Environment conditions for the operation of the inverter:

- ☑ Temperature (standard conditions (measured around the inverter), no frost allowed):
 - 10 °C to 45 °C (14 °F to 113 °F) for frame sizes F and G (except models 720 A and 760 A).
 - 10 °C to 40 °C (14 °F to 104 °F) for frame sizes G (only models 720 A and 760 A) and H.
- ☑ From 40 °C to 45 °C (50 °F to 113 °F) for frame size G (only model 720 A): 2 % of current derating for each Celsius degree above maximum temperature as specified in item above.

From 40 °C to 45 °C (50 °F to 113 °F) for frame sizes G (only model 760 A) and H: 1 % of current derating for each Celsius degree above maximum temperature as specified in item above.

From 45 °C to 55 °C (113 °F to 131 °F) for frame sizes F, G and H: 2 % of current derating for each Celsius degree above maximum temperature as specified in item above.
- ☑ Maximum altitude: up to 1000 m (3.300 ft) - rated conditions.

From 1000 m to 4000 m (3.300 ft to 13.200 ft) - 1 % of current derating for each 100 m (330 ft) (or 0.3 % each 100 ft) above 1000 m (3.300 ft) altitude.

From 2000 m to 4000 m (6.600 ft to 13.200 ft) above sea level - derating of maximum voltage of 1.1 % for each 100 m (330 ft) above 2000 m (6.600 ft).

- ☑ Humidity: from 5 % to 95 % non-condensing.
- ☑ Pollution degree: 2 (according to EN50178 and UL508C) with non-conductive pollution. Condensation shall not originate conduction through the accumulated residues.

3.1.2 Positioning and Mounting

Consult the inverter weight at the [Table 8.1 on page 8-2](#), [Table 8.2 on page 8-3](#) and [Table 8.3 on page 8-5](#).

Mount the inverter in the upright position on a flat and vertical surface.

External dimensions and fixing holes position according to the [Figure 3.1 on page 3-3](#). Refer to the [Section 8.5 MECHANICAL DATA on page 8-8](#) for more details.

First mark the mounting points and drill the mounting holes. Then, position the inverter and firmly tighten the screws in all four corners to secure the inverter.

Minimum mounting clearances requirements for proper cooling air circulation are specified in [Figure 3.2 on page 3-4](#).

Do not install heat sensitive components right above the inverter.



ATTENTION!

When arranging two or more inverters vertically, respect the minimum clearance A + B ([Figure 3.2 on page 3-4](#)) and provide an air deflecting plate so that the heat rising up from the bottom inverter does not affect the top inverter.



ATTENTION!

Provide conduit for physical separation of the signal, control, and power conductors (refer to [Section 3.2 ELECTRICAL INSTALLATION on page 3-8](#)).

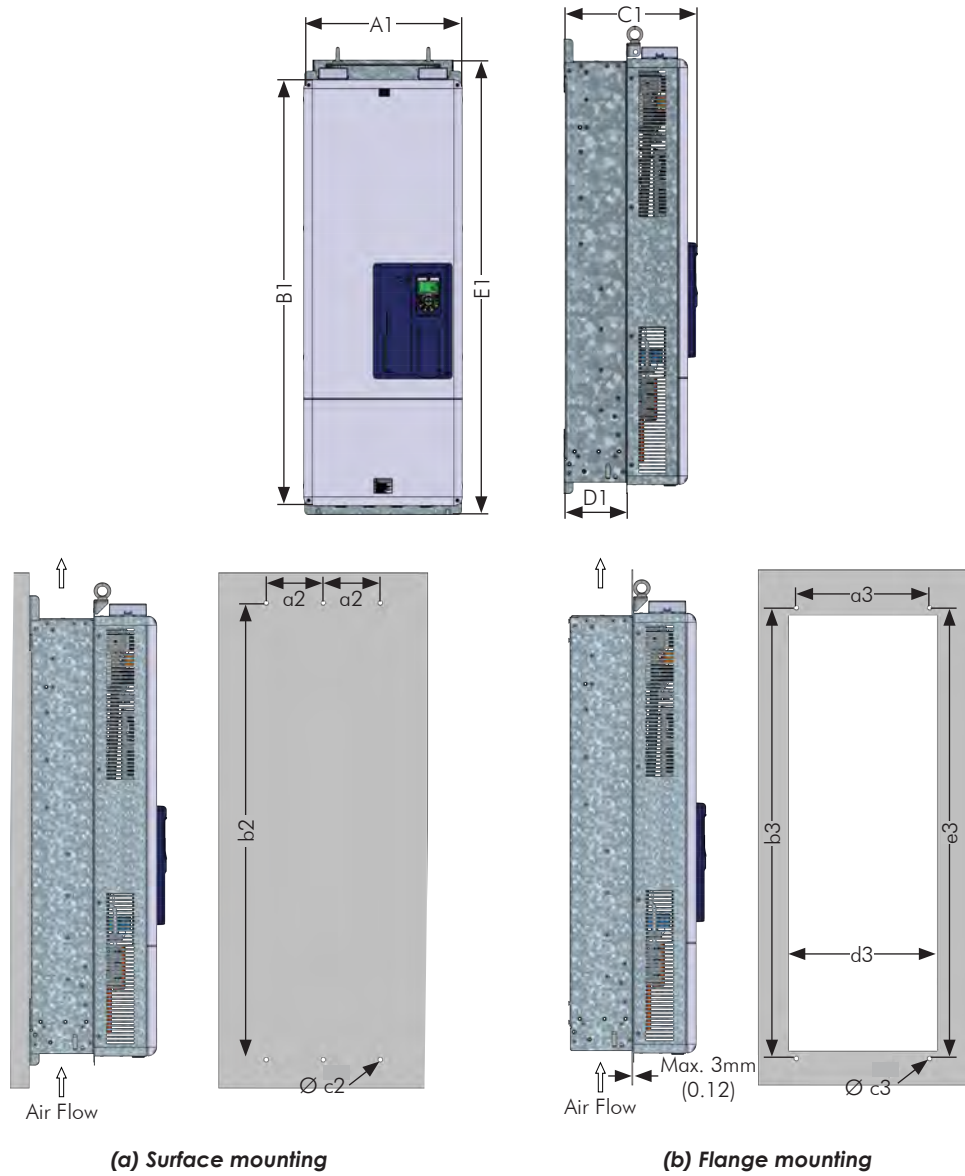

Model	A1	B1	C1	D1	E1	a2	b2	c2	a3	b3	c3	d3	e3	Torque (*)
	mm (in)	mm (in)	mm (in)	mm (in)	mm (in)	mm (in)	mm (in)	M	mm (in)	mm (in)	M	mm (in)	mm (in)	N.m (lbf.in)
Frame size F	430 (16.93)	1156 (45.51)	360 (14.17)	169 (6.65)	1234 (48.58)	150 (5.91)	1200 (47.24)	M10	350 (13.78)	1185 (46.61)	M10	391 (15.39)	1146 (45.12)	35.0 (309.8)
Frame size G	535 (21.06)	1190 (46.85)	426 (16.77)	202 (7.95)	1264 (49.76)	200 (7.87)	1225 (48.23)	M10	400 (15.75)	1220 (48.03)	M10	495 (19.49)	1182 (46.53)	35.0 (309.8)
Frame size H	686.0 (27.00)	1319.7 (51.95)	420.8 (16.56)	171.7 (6.75)	1414 (55.66)	175 (6.88)	1350 (53.14)	M10	595 (23.42)	1345 (52.95)	M10	647 (25.47)	1307 (51.45)	35.0 (309.8)

Tolerance for dimensions d3 and e3: +1.0 mm (+0.039 in).

Tolerance for the other dimensions: ±1.0 mm (±0.039 in).

(*) Recommended torque for the inverter mounting (valid for c2 and c3).

Figure 3.1 - (a) and (b) - Mechanical installation details - mm (in)

3

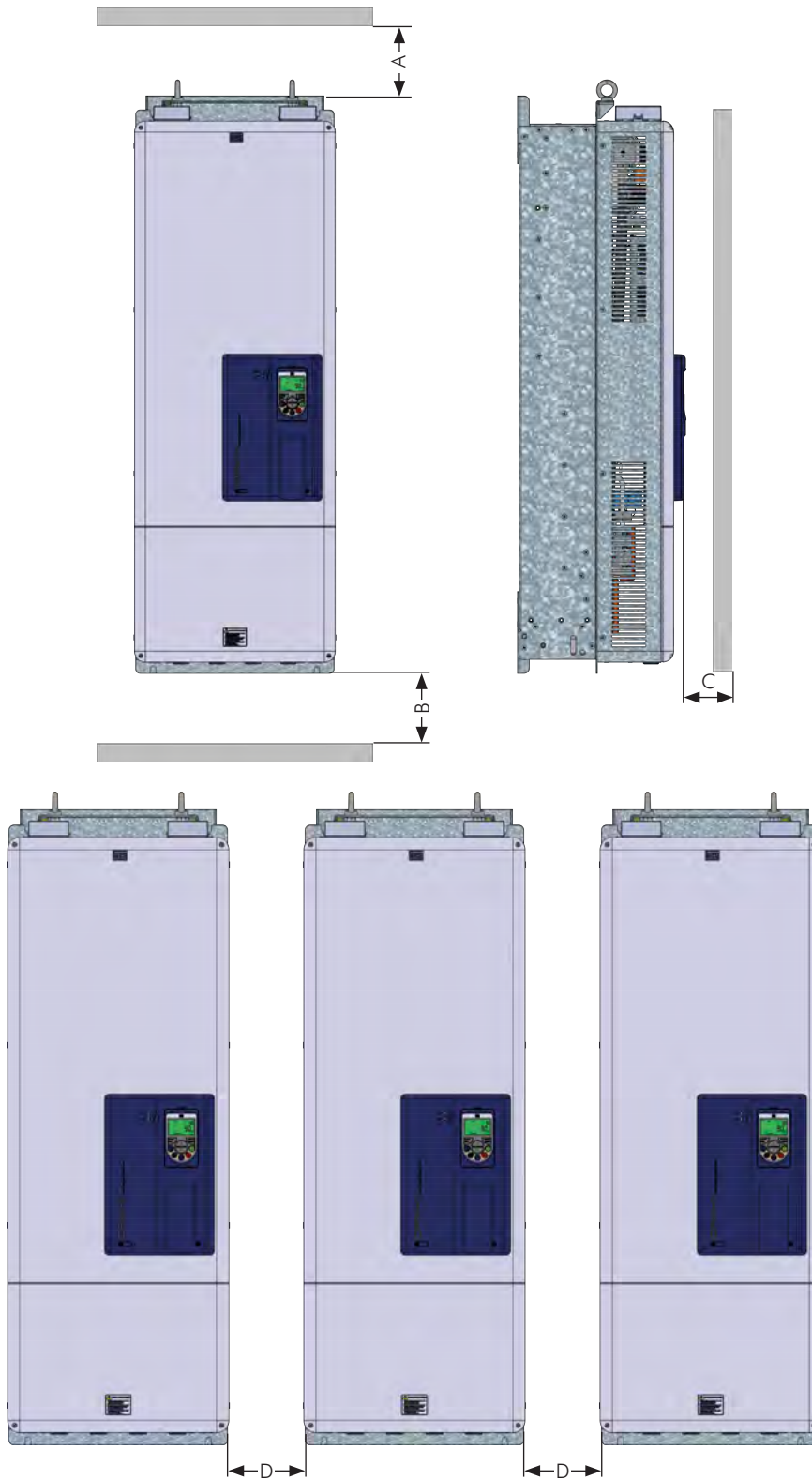

A	B	C	D
mm (in)	mm (in)	mm (in)	mm (in)
150 (5.91)	250 (9.84)	20 (0.78)	80 (3.15)

Tolerance: ±1.0 mm (±0.039 in).

Figure 3.2 - Free space around the inverter for ventilation

3.1.3 Cabinet Mounting

It is possible to mount the inverters in two manners, either on the mounting surface, or with the heatsink mounted outside the cabinet, so that the air for cooling the power heatsink is kept outside the enclosure (flange mounting). For these cases, consider:

Surface mounting:

- ☑ Provide adequate exhaustion, so that the internal cabinet temperature remains within the allowed range for the inverter operation conditions.
- ☑ The power dissipated by the inverter at its rated condition, as specified in [Table 8.1 on page 8-2](#) in the column "Power dissipated in watts, surface mount".
- ☑ Cooling air flow according to the [Table 3.1 on page 3-5](#).
- ☑ The position and diameter of the mounting holes according to the [Figure 3.1 on page 3-3](#).

Flange mounting:



ATTENTION!

The part of the inverter that stays outside the cabinet is rated IP20. See [Section 8.2 ELECTRONICS/ GENERAL DATA on page 8-6](#).

- ☑ The power specified in [Table 8.1 on page 8-2](#) will be dissipated inside the cabinet. The other losses (power modules) will be dissipated at the external ventilation duct.
- ☑ The inverter mounting supports and the hoisting eyes must be removed. Refer to the [Figure 2.4 on page 2-10](#), positions **I** and **J**.
- ☑ Dimensions of the flange-mounting opening and the diameters of the securing holes must be according to the [Figure 3.1 on page 3-3](#).

Table 3.1 - Ventilation air flow (heatsink)

Model	Frame Size	CFM	l/s	m ³ /min
CFW110242T4	F	250	118	7.1
CFW110312T4		320	151	9.1
CFW110370T4		380	180	10.8
CFW110477T4		460	217	13.0
CFW110515T4	G	680	321	19.3
CFW110601T4				
CFW110720T4				
CFW110760T4				
CFW110795T4	H	1100	520	31.2
CFW110877T4				
CFW111062T4				
CFW111141T4				

3.1.4 Access to the Control and Power Terminals

In order to get access to the control terminals, it is necessary to remove the HMI and the control rack cover, as showed in the [Figure 3.3 on page 3-6](#).

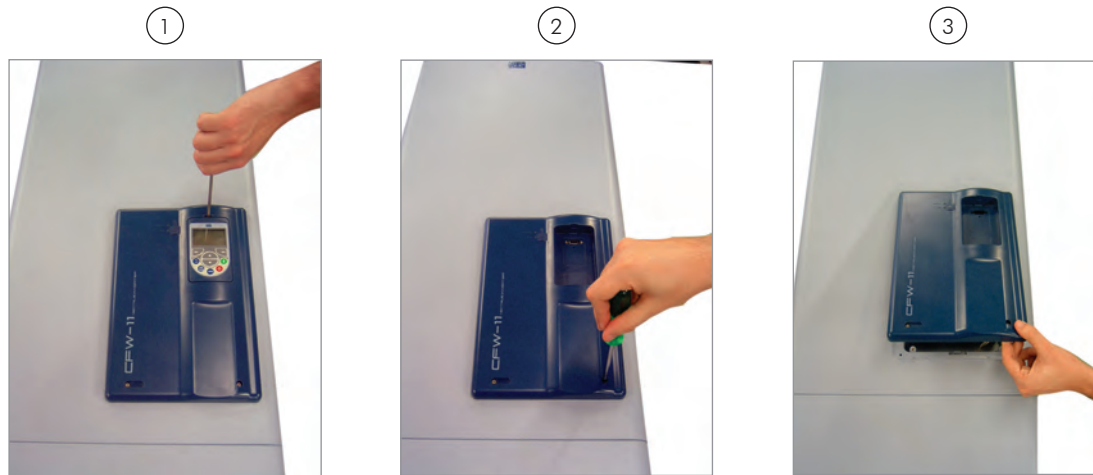

Figure 3.3 - Removal of the HMI and the control rack cover

In order to get access to the power terminals, it is necessary to remove the bottom front cover, as showed in the [Figure 3.4 on page 3-6](#).

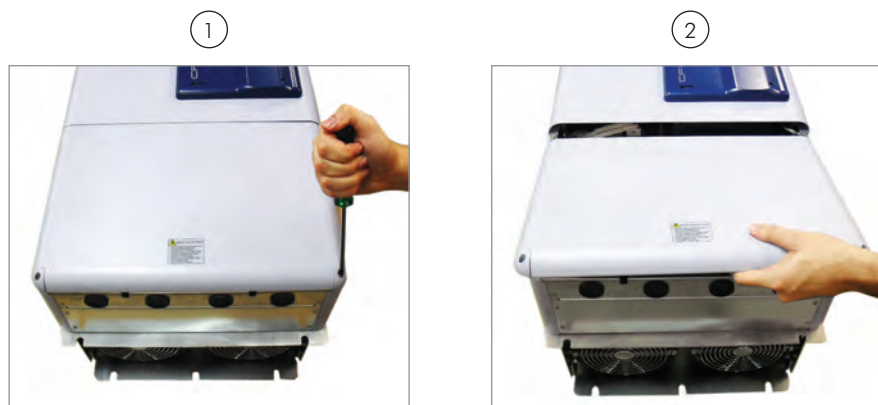

Figure 3.4 - Removal of the bottom front cover, to access to the power supply and motor connection terminals

In order to connect the power cables (line and motor), remove the bottom plate, as showed in the [Figure 3.5 on page 3-7](#). In this case the protection degree of the inverter bottom part will be reduced.

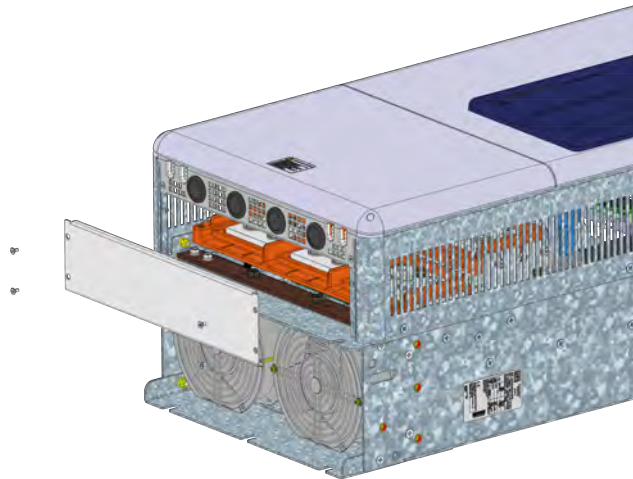

Figure 3.5 - Removal of the bottom plate, to access the power terminals

3.1.5 HMI Installation at the Cabinet Door or Command Panel (Remote HMI)

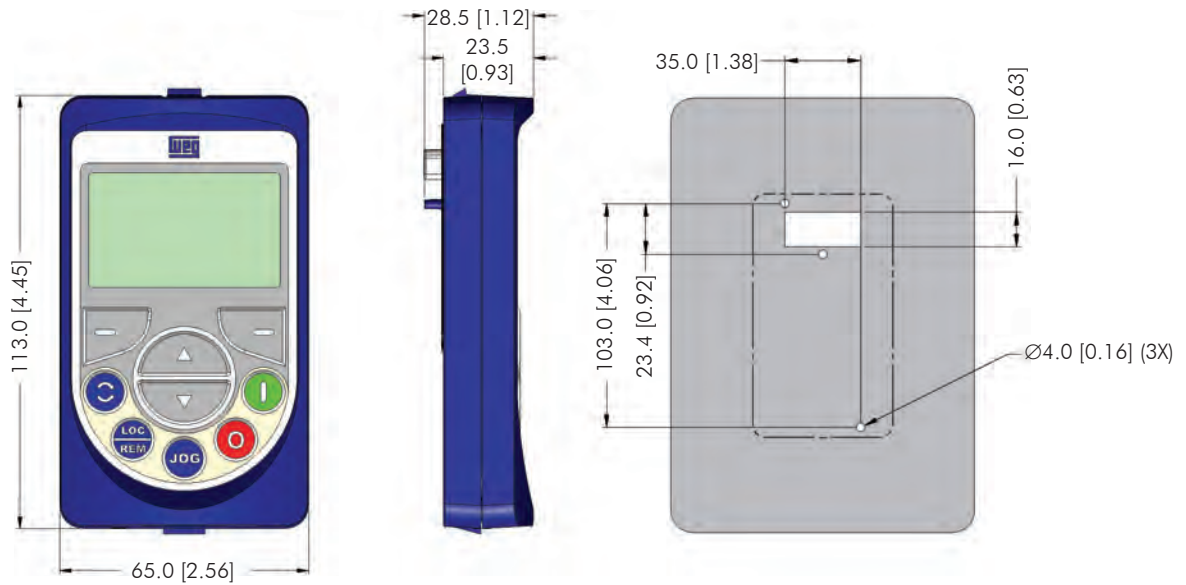

Figure 3.6 - Data for the HMI installation at the cabinet door or command panel – mm [in]

Frame accessory can also be used to install the HMI as mentioned in [Figure 7.1 on page 7-2](#) of accessory models.

3.2 ELECTRICAL INSTALLATION



DANGER!

The following information is merely a guide for proper installation. Comply with applicable local regulations for electrical installations.



DANGER!

Les informations suivantes constituent uniquement un guide pour une installation correcte. Respectez les réglementations locales en vigueur pour les installations électriques.



DANGER!

Make sure the AC power supply is disconnected before starting the installation.



DANGER!

Vérifiez que l'alimentation secteur CA est débranchée avant de commencer l'installation.



ATTENTION!

Integral solid state short circuit protection does not provide branch circuit protection. Branch circuit protection must be provided in accordance with applicable local codes.

3.2.1 Identification of the Power and Grounding Terminals

R/L1 - R1/L1,1 - R2/L1,2 - S/L2 - S1/L2,1 - S2/L2,2 - T/L3 - T1/L3,1 - T2/L3,2: AC power supply.

U/T1 - V/T2 - W/T3: motor connection.

DC+: DC Link positive terminal.

DC-: DC Link negative terminal.

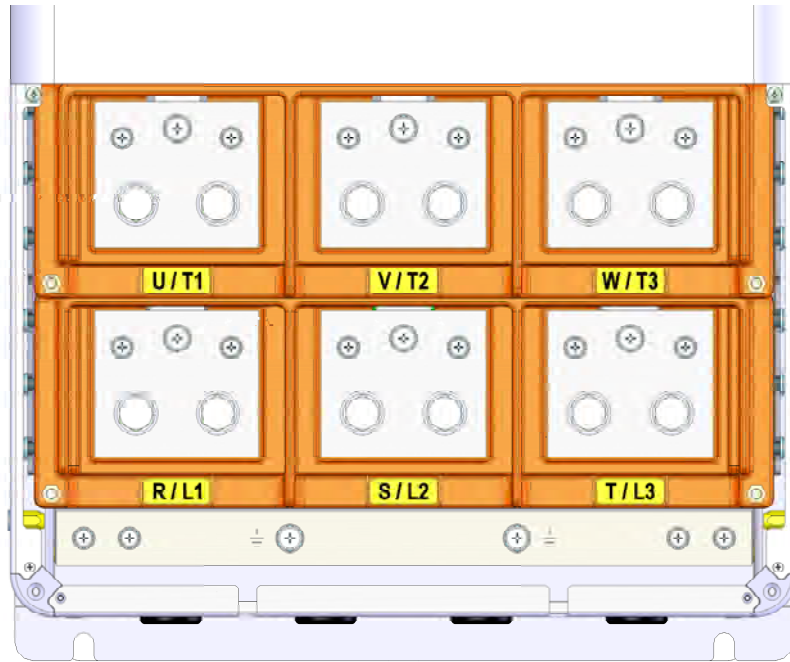

(a) Frame size F power terminals and grounding points



(b) Frame size F DC connection terminals (In models with special DC hardware, the R/L1, S/L2 and T/L3 terminals are not internally connected in this version)



(c) Frame size G power terminals and grounding points



(d) Frame size G DC connection terminals (In models with special DC hardware, the R/L1, S/L2 and T/L3 terminals are not internally connected in this version)

Figure 3.7 - (a) to (d) - Grounding and power terminals of frame sizes F and G

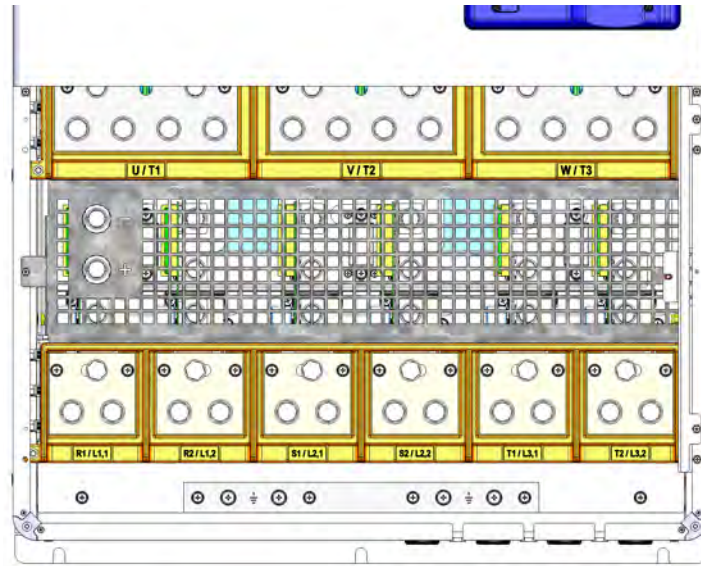

(a) Grounding and power terminals of frame size H

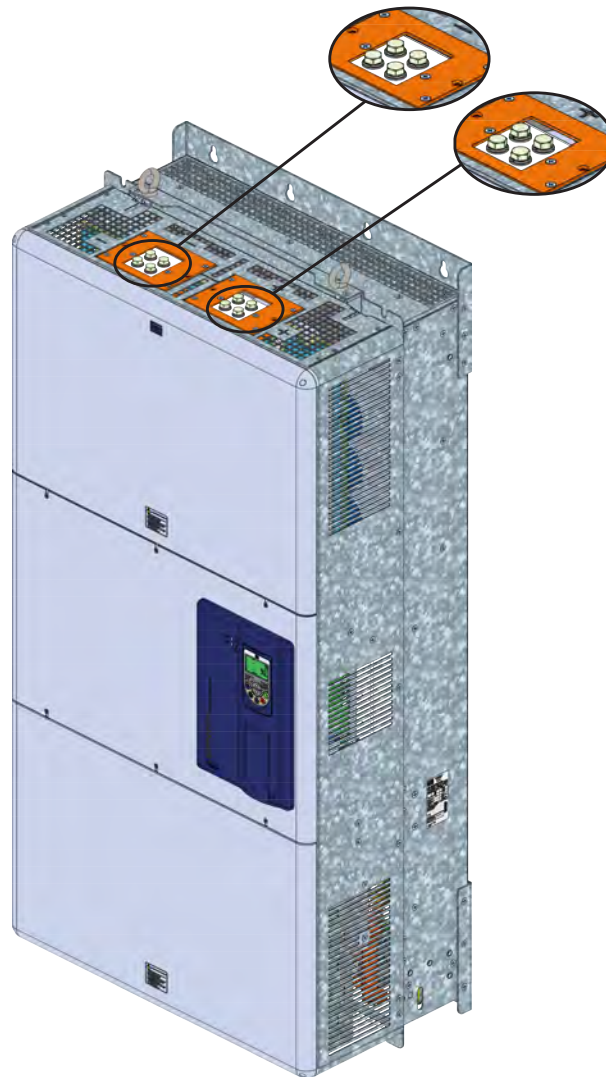

(b) Power terminals of frame size H

Figure 3.8 - (a) and (b) - Grounding and power terminals of frame size H

3.2.2 Power/Grounding Wiring and Fuses



ATTENTION!

Use proper cable lugs for the power and grounding connection cables.



ATTENTION!

Sensitive equipment such as PLCs, temperature controllers, and thermocouple cables, must be kept at a minimum distance of 0.25 m (9.84 in) from the frequency inverter and from the cables connecting the inverter to the motor.



DANGER!

Wrong cable connections:

- The inverter will be damaged if the power supply is connected to the output terminals (U/T1, V/T2, or W/T3).
- Check all the connections before powering up the inverter.
- When replacing an existing inverter by a CFW-11, check if the installation and wiring are according to the instructions listed in this manual.



DANGER!

Mauvaise connexion des câbles:

- Le variateur sera endommagé si l'alimentation d'entrée est connectée aux bornes de sortie (U/T1, V/T2 ou W/T3).
- Vérifier toutes les connexions avant de mettre le variateur sous tension.
- En cas de remplacement d'un variateur existant par un CFW-11, vérifier si l'installation et le câblage sont conformes aux instructions figurant dans ce manuel.



ATTENTION!

Residual Current Device (RCD):

- When installing an RCD to guard against electrical shock, only devices with a trip current of 300 mA should be used on the supply side of the inverter.
- Depending on the installation (motor cable length, cable type, multimotor configuration, etc.), RCD nuisance trips may occur. Contact the RCD manufacturer for selecting the most appropriate device to be used with inverters.



NOTE!

The wire gauges listed in the [Table 3.2 on page 3-13](#) are orientative values. Installation conditions and the maximum permitted voltage drop must be considered for the proper wiring sizing.

Input fuses:

- ☑ Use high speed fuses (semiconductor type) at the input for the protection of the inverter rectifier and wiring. Refer to [Table 3.2 on page 3-13](#) for selecting the appropriate fuse rating (I^2t must be equal to or lower than indicated in [Table 3.2 on page 3-13](#), consider the cold (and not the fusion) current extinction value).
- ☑ In order to meet UL requirements, use fuses according to [Table 3.5 on page 3-19](#).

Table 3.2 - Recommended wire gauge and fuses for standard models - use only copper wire [75 °C (167 °F)]

Model	Frame Size	Power Terminals			Duty Cycle	Wiring			Fuse I^2t @ 25 °C [A ² s]	WEG Recommended Fuses FNH aR Knife Contact			WEG Recommended Fuses FNHFE aR Flush End		
		Terminals	Bolt (wrench/bolt head type)	Recommended Torque N.m (lbf.in)		mm ²	AWG	Terminals		Frame Size	In [A]	Weg Reference	Frame Size	In [A]	Weg Reference
CFW110242T4	F	R/L1 - S/L2 - T/L3 U/T1 - V/T2 - W/T3	M12 (Phillips hex head)	60 (531.00)	HD	2 x 50	2 x 1/0	Ring tongue	320000	2	450	FNH2-450K-A	3	450	FNH3FEM-450Y-A
				ND	2 x 70	2 x 2/0									
		DC+, DC-	M12 (Phillips hex head)	60 (531.00)	HD/ND	2 x 95	2 x 3/0								
			M8 (Phillips hex head)	10 (88.5)	HD/ND	70	2/0								
CFW110312T4	F	R/L1 - S/L2 - T/L3 U/T1 - V/T2 - W/T3	M12 (Phillips hex head)	60 (531.00)	HD	2 x 70	2 x 1/0	Ring tongue	414000	2	630	FNH2-630K-A	3	450	FNH3FEM-450Y-A
				ND	2 x 95	2 x 4/0									
		DC+, DC-	M12 (Phillips hex head)	60 (531.00)	HD/ND	2 x 120	2 x 4/0								
			M8 (Phillips hex head)	10 (88.5)	HD/ND	120	4/0								
CFW110370T4	F	R/L1 - S/L2 - T/L3 U/T1 - V/T2 - W/T3	M12 (Phillips hex head)	60 (531.00)	HD	2 x 120	2 x 4/0	Ring tongue	414000	2	710	FNH2-710K-A	3	500	FNH3FEM-500Y-A
				ND	2 x 120	2 x 4/0									
		DC+, DC-	M12 (Phillips hex head)	60 (531.00)	HD/ND	2 x 150	2 x 300								
			M8 (Phillips hex head)	10 (88.5)	HD/ND	120	4/0								
CFW110477T4	F	R/L1 - S/L2 - T/L3 U/T1 - V/T2 - W/T3	M12 (Phillips hex head)	60 (531.00)	HD	2 x 120	2 x 4/0	Ring tongue	1051000	3	900	FNH2-900K-A	3	630	FNH3FEM-630Y-A
				ND	2 x 185	2 x 350									
		DC+, DC-	M12 (Phillips hex head)	60 (531.00)	HD/ND	2 x 240	2 x 500								
			M8 (Phillips hex head)	10 (88.5)	HD/ND	185	350								

Installation and Connection









Model Frame Size	Power Terminals			Duty Cycle	Wiring			Fuse I ² t @ 25 °C [A ² s]	WEG Recommended Fuses FNH aR Knife Contact			WEG Recommended Fuses FNHFE aR Flush End			
	Terminals	Bolt (wrench/bolt head type)	Recom- mended Torque N.m (lbf.in)		mm ²	AWG	Terminals		Frame Size	In [A]	Weg Reference	Frame Size	In [A]	Weg Reference	
CFW110515T4	R/L1 - S/L2 - T/L3 - U/T1 - V/T2 - W/T3	M12 (Phillips hex head)	60 (531.00)	HD	3 x 120	3 x 4/0	Ring tongue	1445000	3	1000	FNH2- 1000K-A	3	700	FNH3FEM- 700Y-A	
				ND	3 x 120	3 x 4/0									
	DC+, DC-	M12 (Phillips hex head)	60 (531.00)	HD/ND	76 mm ⁽²⁾	3 in ⁽²⁾									
	⊕	M8 (Phillips hex head)	10 (88.5)	HD/ND	120	4/0									
CFW110601T4	R/L1 - S/L2 - T/L3 - U/T1 - V/T2 - W/T3	M12 (Phillips hex head)	60 (531.00)	HD	3 x 120	3 x 4/0	Ring tongue	1445000	3	2 x 630	FNH2- 630K-A	3	800	FNH3FEM- 800Y-A	
				ND	3 x 150	3 x 300									
	DC+, DC-	M12 (Phillips hex head)	60 (531.00)	HD/ND	76 mm ⁽²⁾	3 in ⁽²⁾									
	⊕	M8 (Phillips hex head)	10 (88.5)	HD/ND	150	300									
CFW110720T4	R/L1 - S/L2 - T/L3 - U/T1 - V/T2 - W/T3	M12 (Phillips hex head)	60 (531.00)	HD	3 x 120	3 x 4/0	Ring tongue	1445000	3	2 x 710	FNH2- 710K-A	3	900	FNH3FEM- 900Y-A	
				ND	3 x 185	3 x 350									
	DC+, DC-	M12 (Phillips hex head)	60 (531.00)	HD/ND	102 mm ⁽²⁾	4 in ⁽²⁾									
	⊕	M8 (Phillips hex head)	10 (88.5)	HD/ND	185	350									
CFW110760T4	R/L1 - S/L2 - T/L3 - U/T1 - V/T2 - W/T3	M12 (Phillips hex head)	60 (531.00)	HD	3 x 150	3 x 300	Ring tongue	1445000	3	2 x 710	FNH2- 710K-A	3	900	FNH3FEM- 900Y-A	
				ND	3 x 185	3 x 500									
	DC+, DC-	M12 (Phillips hex head)	60 (531.00)	HD/ND	102 mm ⁽²⁾	4 in ⁽²⁾									
	⊕	M8 (Phillips hex head)	10 (88.5)	HD/ND	185	500									

Model Frame Size	Power Terminals			Duty Cycle	Wiring			Fuse I ² t @ 25 °C [A ² s]	WEG Recommended Fuses FNH aR Knife Contact			WEG Recommended Fuses FNHFE aR Flush End			
	Terminals	Bolt (wrench/bolt head type)	Recom- mended Torque N.m (lbf.in)		mm ²	AWG	Terminals		Frame Size	In [A]	Weg Reference	Frame Size	In [A]	Weg Reference	
CFW110795T4	R1/L1,1 - R2/L1,2 - S1/L2,1 - S2/L2,2 - T1/L3,1 - T2/L3,2 U/T1 - V/T2 - W/T3	M12 (Phillips hex head)	60 (531.00)	HD	4 x 120	4 x 4/0	Ring tongue	1051000	3	2 x 800	FNH2- 800K-A	3	1000	FNH3FEM- 1000Y-A	
				ND	4 x 150	4 x 300									
	DC+, DC-	M12 (Phillips hex head)	60 (531.00)	HD/ND	102 mm ⁽²⁾	4 in ⁽²⁾									
	⊕	M8 (Phillips hex head)	10 (88.5)	HD/ND	2 x 70	2 x 2/0									
CFW110877T4	R1/L1,1 - R2/L1,2 - S1/L2,1 - S2/L2,2 - T1/L3,1 - T2/L3,2 U/T1 - V/T2 - W/T3	M12 (Phillips hex head)	60 (531.00)	HD	4 x 120	4 x 4/0	Ring tongue	1051000	3	2 x 800	FNH2- 800K-A	3	1000	FNH3FEM- 1000Y-A	
				ND	4 x 150	4 x 300									
	DC+, DC-	M12 (Phillips hex head)	60 (531.00)	HD/ND	2 x 76 mm ⁽²⁾	2 x 3 in ⁽²⁾									
	⊕	M8 (Phillips hex head)	10 (88.5)	HD/ND	2 x 120	2 x 4/0									
CFW111062T4 ⁽¹⁾	R1/L1,1 - R2/L1,2 - S1/L2,1 - S2/L2,2 - T1/L3,1 - T2/L3,2 U/T1 - V/T2 - W/T3	M12 (Phillips hex head)	60 (531.00)	HD	4 x 150	4 x 300	Ring tongue	1445000	3	2 x 900	FNH2- 900K-A	3	1250	FNH3FEM- 1250Y-A	
				ND	4 x 240	4 x 500									
	DC+, DC-	M12 (Phillips hex head)	60 (531.00)	HD/ND	2 x 76 mm ⁽²⁾	2 x 3 in ⁽²⁾									
	⊕	M8 (Phillips hex head)	10 (88.5)	HD/ND	2 x 120	2 x 4/0									
CFW111141T4 ⁽¹⁾	R1/L1,1 - R2/L1,2 - S1/L2,1 - S2/L2,2 - T1/L3,1 - T2/L3,2 U/T1 - V/T2 - W/T3	M12 (Phillips hex head)	60 (531.00)	HD	4 x 185	4 x 350	Ring tongue	1445000	3	2 x 900	FNH2- 900K-A	3	1400	FNH3FEM- 1400Y-A	
				ND	4 x 240	4 x 500									
	DC+, DC-	M12 (Phillips hex head)	60 (531.00)	HD/ND	2 x 102 mm ⁽²⁾	2 x 4 in ⁽²⁾									
	⊕	M8 (Phillips hex head)	10 (88.5)	HD/ND	2 x 150	2 x 300									

(1) For these applications, the fuses cannot be installed on FSW and RPW switch-disconnectors – only on BNH individual mounting bases.
 (2) 6.4 mm (1/4 in) copper bus bar must be used with width specified in Table 3.2 on page 3-13.

Installation and Connection

Table 3.3 - Recommended Wiring/Fuses for models with DC power supply (special DC Hardware) – use copper wiring only (75 °C) (167 °F)

Model	Frame Size	Power Terminals			Duty Cycle	Wiring		Fuse [A]	Fuse I ² t @ 25 °C Terminals [A ² s]		
		Terminals	Bolt (wrench/bolt head type)	Recommended Torque N.m (lbf.in)		mm ²	AWG			Terminals	
CFW110242T4DC	F	U/T1 - V/T2 - W/T3	M12 (Phillips hex head)	60 (531.00)	HD	2 x 50	2 x 1/0	Ring tongue	420	See note (2)	
					ND	2 x 70	2 x 1/0				
		DC+, DC-	M12 (Phillips hex head)	60 (531.00)	HD/ND	2 x 95	2 x 3/0				
				M8 (Phillips hex head)	10 (88.5)	HD/ND	70	1/0			
CFW110312T4DC		U/T1 - V/T2 - W/T3	M12 (Phillips hex head)	60 (531.00)	HD	2 x 70	2 x 1/0	Ring tongue	540	See note (2)	
					ND	2 x 120	2 x 4/0				
		DC+, DC-	M12 (Phillips hex head)	60 (531.00)	HD/ND	2 x 120	2 x 4/0				
				M8 (Phillips hex head)	10 (88.5)	HD/ND	120	4/0			
CFW110370T4DC		U/T1 - V/T2 - W/T3	M12 (Phillips hex head)	60 (531.00)	HD	2 x 120	2 x 4/0	Ring tongue	640	See note (2)	
				ND	2 x 120	2 x 4/0					
	DC+, DC-	M12 (Phillips hex head)	60 (531.00)	HD/ND	2 x 150	2 x 300					
			M8 (Phillips hex head)	10 (88.5)	HD/ND	120	4/0				
CFW110477T4DC	U/T1 - V/T2 - W/T3	M12 (Phillips hex head)	60 (531.00)	HD	2 x 120	2 x 4/0	Ring tongue	830	See note (2)		
				ND	2 x 185	2 x 350					
	DC+, DC-	M12 (Phillips hex head)	60 (531.00)	HD/ND	76 mm (1)	3 in (1)					
			M8 (Phillips hex head)	10 (88.5)	HD/ND	185	350				
CFW110515T4DC	U/T1 - V/T2 - W/T3	M12 (Phillips hex head)	60 (531.00)	HD	3 x 120	3 x 4/0	Ring tongue	890	See note (2)		
				ND	3 x 120	3 x 4/0					
	DC+, DC-	M12 (Phillips hex head)	60 (531.00)	HD/ND	76 mm (1)	3 in (1)					
			M8 (Phillips hex head)	10 (88.5)	HD/ND	120	4/0				
CFW110601T4DC	U/T1 - V/T2 - W/T3	M12 (Phillips hex head)	60 (531.00)	HD	3 x 120	3 x 4/0	Ring tongue	1035	See note (2)		
				ND	3 x 150	3 x 300					
	DC+, DC-	M12 (Phillips hex head)	60 (531.00)	HD/ND	76 mm (1)	3 in (1)					
			M8 (Phillips hex head)	10 (88.5)	HD/ND	150	300				
CFW110720T4DC	U/T1 - V/T2 - W/T3	M12 (Phillips hex head)	60 (531.00)	HD	3 x 120	3 x 4/0	Ring tongue	1245	See note (2)		
				ND	3 x 185	3 x 350					
	DC+, DC-	M12 (Phillips hex head)	60 (531.00)	HD/ND	102 mm (1)	4 in (1)					
			M8 (Phillips hex head)	10 (88.5)	HD/ND	185	350				
CFW110760T4DC	U/T1 - V/T2 - W/T3	M12 (Phillips hex head)	60 (531.00)	HD	3 x 150	3 x 300	Ring tongue	1245	See note (1)		
				ND	3 x 185	3 x 500					
	DC+, DC-	M12 (Phillips hex head)	60 (531.00)	HD/ND	102 mm (1)	4 in (1)					
			M8 (Phillips hex head)	10 (88.5)	HD/ND	185	500				

Model	Frame size	Power terminals			Duty cycle	Wiring			Fuse [A]	Fuse I ² t @ 25 °C Terminals [A ² s]
		Terminals	Bolt (wrench/bolt head type)	Recommended torque N.m (lbf.in)		mm ²	AWG	Terminais		
CFW110795T4DC	H	U/T1 - V/T2 - W/T3	M12 (Phillips hex head)	60 (531.00)	HD	3 x 150	3 x 300	Ring tongue	2 x 800	See note (2)
					ND	3 x 185	3 x 400			
		DC+, DC-	M12 (Phillips hex head)	60 (531.00)	HD/ND	102 mm (4)	4 in (4)			
CFW110877T4DC		U/T1 - V/T2 - W/T3	M12 (Phillips hex head)	60 (531.00)	HD	4 x 120	4 x 4/0	Ring tongue	2 x 800	See note (2)
					ND	4 x 150	4 x 300			
		DC+, DC-	M12 (Phillips hex head)	60 (531.00)	HD/ND	2 x 76 mm (4)	2 x 3 in (4)			
CFW111062T4DC (3)		U/T1 - V/T2 - W/T3	M12 (Phillips hex head)	60 (531.00)	HD	4 x 150	4 x 300	Ring tongue	2 x 900	See note (2)
					ND	4 x 240	4 x 500			
		DC+, DC-	M12 (Phillips hex head)	60 (531.00)	HD/ND	2 x 76 mm (4)	2 x 3 in (4)			
CFW111141T4DC (3)	U/T1 - V/T2 - W/T3	M12 (Phillips hex head)	60 (531.00)	HD	2 x 120	2 x 4/0	Ring tongue	2 x 900	See note (2)	
				ND	4 x 185	4 x 350				
	DC+, DC-	M12 (Phillips hex head)	60 (531.00)	HD/ND	2 x 102 mm (4)	2 x 4 in (4)				

(1) 6.4 mm (1/4 in) copper bus bar must be used with width specified in Table 3.3 on page 3-16.

(2) Use fuses with I²t value smaller than or equal to the value specified in Table 3.2 on page 3-13 and voltage and breaking capacity for 800 Vdc.

(3) For these applications, the fuses cannot be installed on FSW and RPW switch-disconnectors – only on BNH individual mounting bases.

Table 3.4 - (a) and (b) - Recommended terminals for power connections

(a) Cables with size in mm²

Wire Size [mm ²]	Screw	Manufacturer	Lug Terminal, Code	Crimping Tool Code	Number of Crimps
50	M8	Burndy (FCI)	YA1CL	Tool without die: MY29-3 or Y644 or Y81 Tool+die: Y46 ou Y35 or Y750 / U1CRT	1
		Tyco	36916	Manual tool: 1490748-1 Jaw: 1490413-5 + 1490414-3	
70	M8	Hollingsworth	RM 70-8	H 6.500	1
		Burndy (FCI)	YA26L	Tool without die: MY29-3 or Y644 or Y81 Tool+die: Y46 or Y35 or Y750 / U26RT	
		Tyco	321870	Manual tool: 1490748-1 Jaw: 1490413-6 + 1490414-3	
	M12	Hollingsworth	RM70-12	H 6.500	1
Tyco		710028-5	Manual hydraulic compression tool (Item TE: 1490749-1) Mold: 1583098-1		
120	M8	Hollingsworth	RM 120-8	H 6.500	1
		Tyco	709820-1	Manual hydraulic compression tool (Item TE: 1490749-1) Mold: 1583098-1	
	M12	Hollingsworth	RM120-12	H 6.500	1
		Tyco	709820-3	Manual hydraulic compression tool (Item TE: 1490749-1) Mold: 1583098-1	
150	M8	Hollingsworth	RM 150-8	H 6.500	1
	M12	Hollingsworth	RM150-12	H 6.500	
		Tyco	709821-3	Manual hydraulic compression tool (Item TE: 1490749-1) Mold: 1752868-1 + 46751-2	
185	M12	Hollingsworth	RM185-12	Hydraulic tool : H6-500	1
		Burndy (FCI)	YA31L	Dieless tool: Y644 or Y81 Tool + die: Y35 or Y750 / U31RT	1
240	M12	Hollingsworth	RM240-12	Hydraulic tool: H6-500	1
		Burndy (FCI)	YA34L6	Dieless tool: Y644 or Y81 Tool + die: Y35 or Y750 / U34RT	1

(b) Cables with size in AWG

Wire Size [AWG/kcmil]	Screw	Manufacturer	Lug Terminal, Code	Crimping Tool Code	Number of Crimps
1/0	M8	Hollingsworth	R 10516	H 6.500	1
		Burndy (FCI)	YA25L	Tool without die: MY29-3 or Y644 or Y81 Tool+die: Y46 or Y35 or Y750 / U25RT	
		Tyco	36916	Manual tool: 1490748-1 Jaw: 1490413-5 + 1490414-3	
2/0	M8	Hollingsworth	20516	H 6.500	1
		Burndy (FCI)	YA26L	Tool without die: MY29-3 or Y644 or Y81 Tool+die: Y46 or Y35 or Y750 / U26RT	
		Tyco	321870	Manual tool: 1490748-1 Jaw: 1490413-6 + 1490414-3	
	M12	Hollingsworth	R 4038	H 6.500	1
Tyco	709820-3	Manual hydraulic compression tool (Item TE: 1490749-1) Mold: 1583098-1			
4/0	M8	Hollingsworth.	R 2038	H 6.500	1
		Tyco	709820-1	Manual hydraulic compression tool (Item TE: 1490749-1) Mold: 1583098-1	
	M12	Hollingsworth	R 4038	H 6.500	1
		Tyco	709820-3	Manual hydraulic compression tool (Item TE: 1490749-1) Mold: 1583098-1	
300	M12	Hollingsworth	RM150-12	H 6.500	1
		Tyco	709821-3	Manual hydraulic compression tool (Item TE: 1490749-1) Mold: 1752868-1 + 46751-2	
350	M12	Hollingsworth	R 35012	Hydraulic Tool: H6-500	1
		Burndy (FCI)	YA31L	Dieless tool: Y644 or Y81 Tool + die: Y35 or Y750 / U31RT	1
500	M12	Hollingsworth	R 50012	Hydraulic Tool: H6-500	1
		Burndy (FCI)	YA34L6	Dieless tool: Y644 or Y81 Tool + die: Y35 or Y750 / U34RT	1

Table 3.5 - Fuses and circuit breaker specifications according to UL and IEC standard

Model	Inverter Protection With Fuses ⁽¹⁾			Inverter Protection With Inverse-Time Circuit Breaker		
	Maximum Rated Current of Input Fuses	Fuse Type / Reference	Maximum Power Supply Short-Circuit Current	Maximum Rated Current of Circuit Breaker, in % of Motor Rated Current (FLA) ⁽¹⁾	Minimum Cabinet Dimensions (Depth X Height X Width)	Maximum Power Supply Short-Circuit Current
CFW11 0242 T 4	700 A	Class J fuse	100 kA @ 480 V	300 %	600 x 2000 x 800 mm (23.6 x 78.7 x 31.5 in)	65 kA @ 480 V
CFW11 0312 T 4				250 %		
CFW11 0370 T 4				200 %		
CFW11 0477 T 4				150 %		
CFW11 0515 T 4	900 A	Class J fuse		225 %	600 x 2000 x 1400 mm (23.6 x 78.7 x 55.1 in)	
CFW11 0601 T 4				200 %		
CFW11 0720 T 4				167 %		
CFW11 0760 T 4				158 %		
CFW11 0795 T 4	2 x 900 A	WEG high speed FNH3-900K-A / Bussmann FBP-900 / Mersen Ferraz A070URD32KI0900		200 %	600 x 2000 x 1400 mm (23.6 x 78.7 x 55.1 in)	
CFW11 0877 T 4				175 %		
CFW11 1062 T 4				150 %		
CFW11 1141 T 4				140 %		

(1) Those values were defined considering UL requirements (safety and damage to the complete installation) and not the limit to not destroy internal components of the inverter (e.g. rectifier module). If that is the case, it's required to use semiconductor fuses with I²t equal to or lower than the specified in Table 3.2 on page 3-13 (only suitable semiconductor fuses can provide protection for input components such as rectifiers).

3.2.3 Power Connections

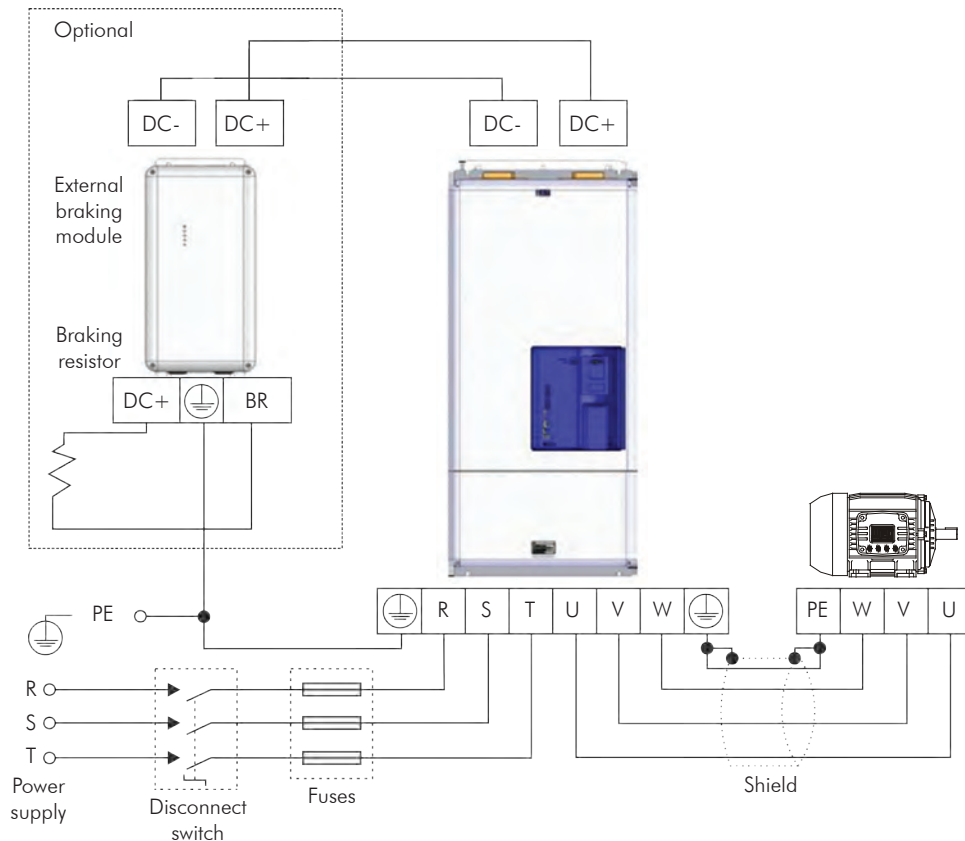

(a) Models with alternating current power supply (IP20)

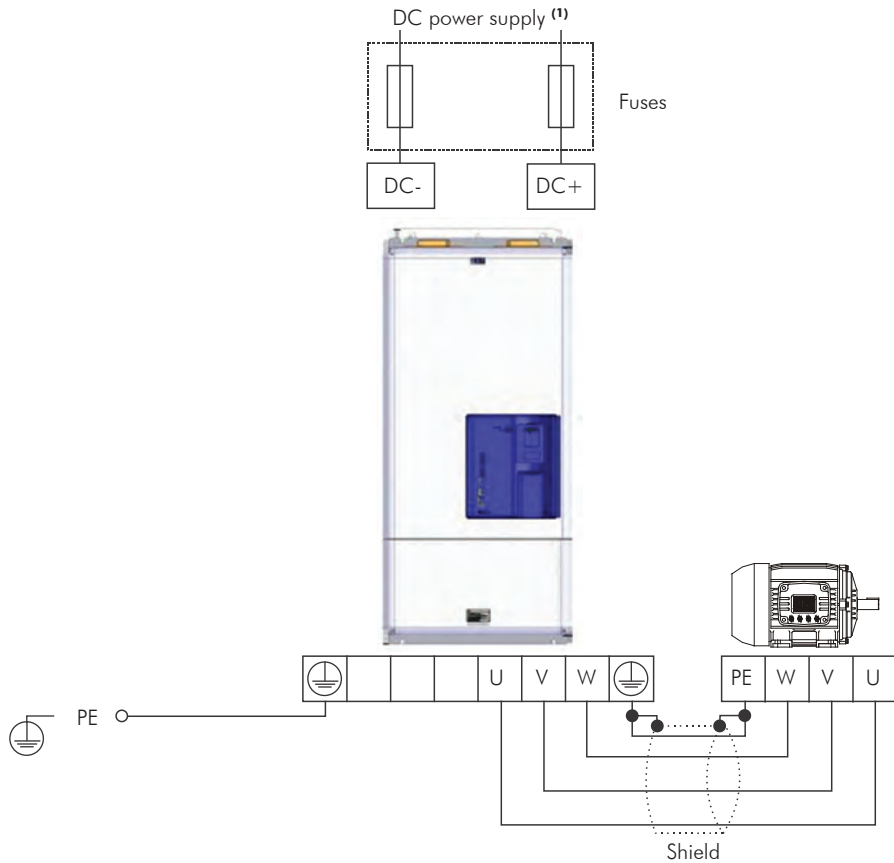

(b) Models with DC power supply (degree of protection IP00 - special DC hardware)

(1) According to Chapter 8 TECHNICAL SPECIFICATIONS on page 8-1, Table 8.2 on page 8-3.

Figure 3.9 - (a) and (b) - Power and grounding connections - frame sizes F and G

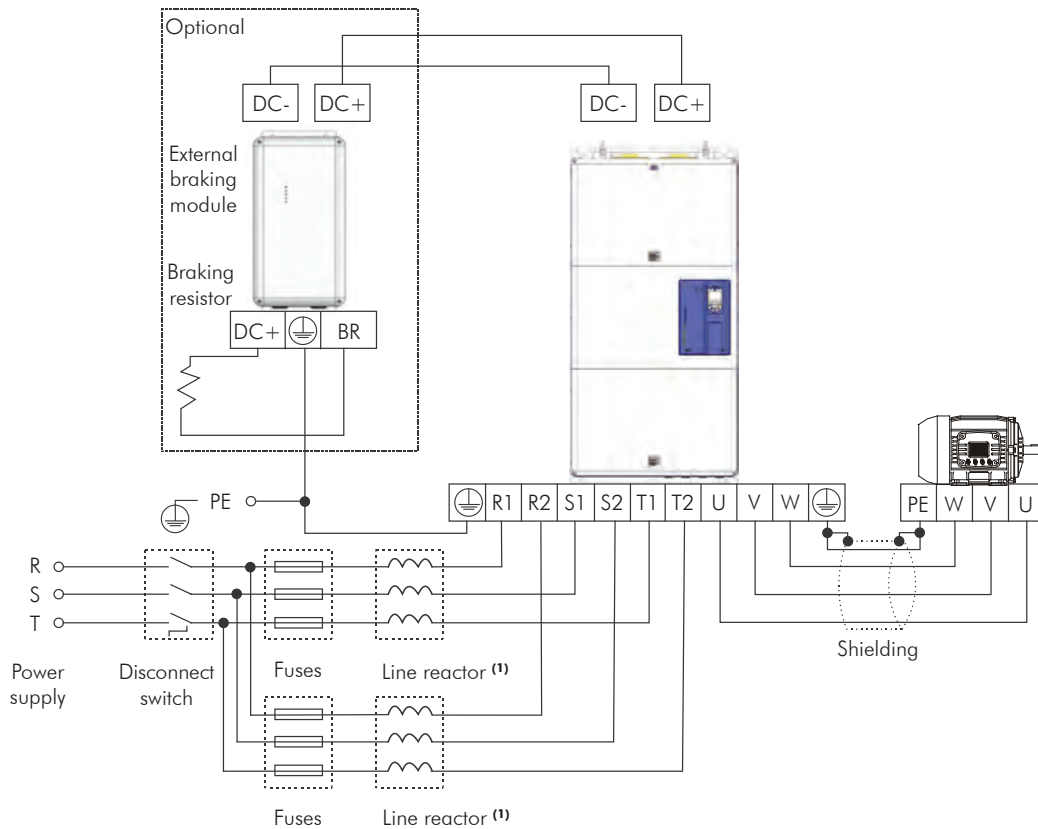

(a) Models with AC power supply (IP20 degree of protection) - frame size H

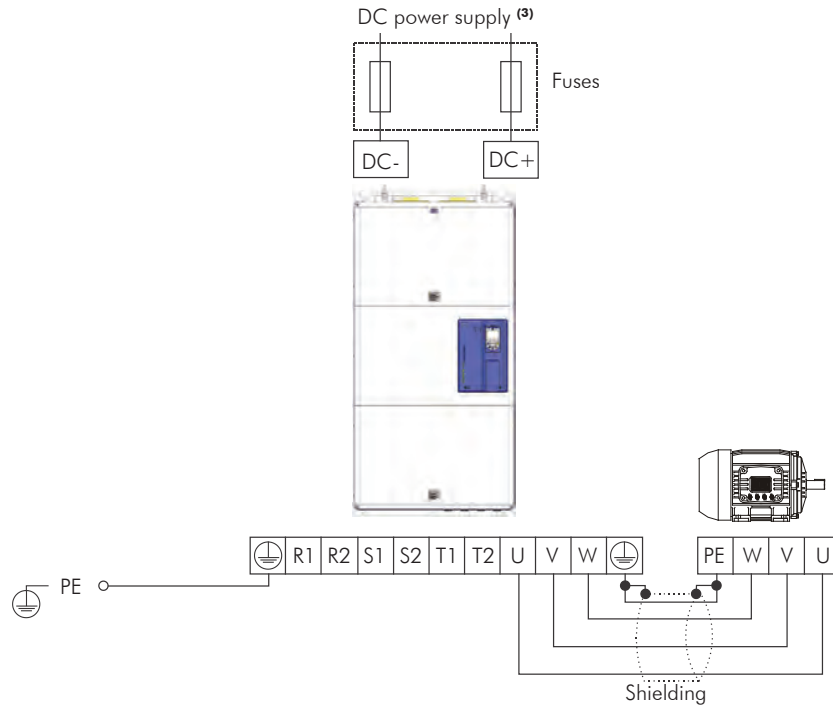

(b) Models with direct current power supply (IP00 degree of protection) - special hardware DC ⁽²⁾ - frame size H

(1) For frame size H models, two line reactances are required with minimum voltage drop of 3 % under rated condition of the inverter.

$$L = 919 \cdot \frac{\Delta V [\%] \cdot V_{LL} [V]}{f_r [\text{Hz}] \cdot I [A]} [\mu\text{H}]$$

ΔV = Percentage voltage drop.

V_{LL} = Inverter supply line voltage.

f_r = Line frequency.

I = Reactor current. That is equal to rms input current for models 584T6 and 625T6. In models 758T6 and 804T6 as it's used 2 reactors per inverter, reactor current is half of the total rms input current – for thermal and saturation design of line reactors in this case also consider a current unbalance of 15 % between the reactors as specified in note (2) below.

(2) For frame size H models 758T6 and 804T6 it's necessary two line reactors with 3 % voltage drop minimum each. Use the equation provided in note (1) to calculate inductance L value. For example, for 804T6 model with 690Vac/50Hz power supply $L=108\mu\text{H}$. For thermal and saturation design of line reactors consider half the total rms current of the inverter and a current unbalance of 15 % between the reactors. For example in model 758T6 with 575 Vac power supply, the maximum current in each reactor is $1.15 \cdot (758/2)=436\text{A}$.

(3) According to [Chapter 8 TECHNICAL SPECIFICATIONS on page 8-1, Table 8.2 on page 8-3.](#)

Figure 3.10 - (a) and (b) - Power and grounding connections - frame size H

3.2.3.1 Input Connections

**DANGER!**

Provide a disconnect device for the input power supply of the inverter.

This device must disconnect the power line from the inverter input (at low voltage) when necessary (for example: during maintenance jobs).

**DANGER!**

Montez un dispositif de coupure sur l'alimentation du variateur.

Cet appareil doit déconnecter la ligne d'alimentation de l'entrée de l'onduleur (à basse tension) lorsque cela est nécessaire (par exemple : lors de travaux de maintenance).

**ATTENTION!**

A contactor or another device that frequently disconnects and reapplies the AC supply to the inverter, in order to start and stop the motor, may cause damage to the inverter power section. The drive is designed to use control signals for starting and stopping the motor. If used for that purpose, the input device must not exceed one operation per minute; otherwise, the inverter may be damaged.

**ATTENTION!**

The power supply that feeds the inverter must have a grounded neutral. In case of IT networks, follow the instructions described in [Item 3.2.3.1.2 IT Networks on page 3-23](#).

**NOTE!**

The input power supply voltage must be compatible with the inverter rated voltage.

**NOTE!**

Power factor correction capacitors are not needed at the inverter input (R, S, T) and must not be installed at the output (U, V, W).

**NOTE!**

For models with special DC hardware an external pre-charge circuit must be provided. For further information, refer to the manufacturer.

3.2.3.1.1 Power Supply Capacity

- ☑ Suitable for circuits with capacity to deliver no more than:
 - 100 kA symmetric at 240 V or 480 V when the inverter is protected by fuses;
 - 65 kA symmetric at 240 V or 480 V when the inverter is protected by inverse time circuit breaker.

- ☑ For compliance with UL standard refer to [Table 3.5 on page 3-19](#).

3.2.3.1.2 IT Networks



ATTENTION!

To use frame sizes F, G and H inverters in IT networks (neutral ungrounded or grounded through a high ohmic value resistor), or in corner-grounded delta networks, it is necessary to disconnect the cable with the ring tongue lug from the ground busbar and connect it to the isolated point on the power terminal block, as showed in the [Figure 3.11 on page 3-23](#) and [Figure 3.12 on page 3-23](#). This is necessary to avoid damages when operating with a line input short circuited with the ground.



NOTE!

The ground-fault protection (F074) is intended for IGBT protection and may not be activated when inverter output is shorted to ground, when fed by IT networks. External insulation monitoring devices should be used for system fault monitoring.

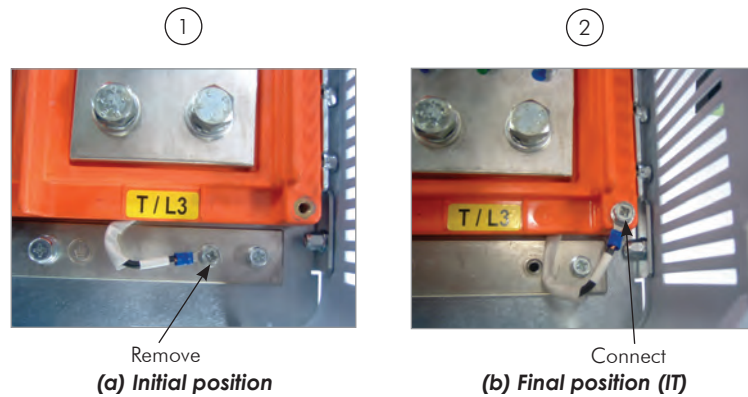

Figure 3.11 - (a) and (b) - Ground connections - location and procedure for adapting to IT or corner-ground networks

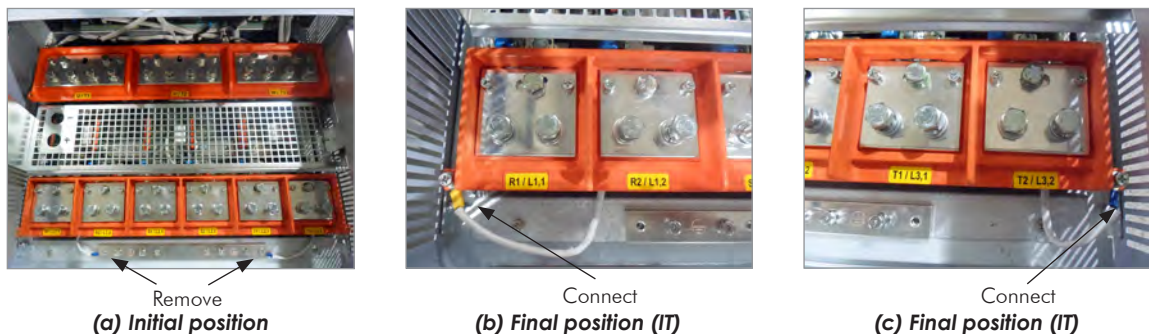

Figure 3.12 - Grounding connections – location and procedure to adapt to the IT or delta-grounded networks – frame size H

3.2.3.1.3 Command Fuses of Pre-charge Circuit

- ☑ Specifications of the used auxiliary fuse:
4 A / 690 V slow blow fuse.
Manufacturer: Ferraz Shawmut.
Commercial reference: 17019-G.
WEG part number 10411503.

3.2.3.2 Dynamic Braking



ATTENTION!

Frame sizes F, G and H models do not have internal braking IGBT. When necessary, braking modules and external resistors should be installed, as shown in [Figure 3.13 on page 3-26](#).



NOTE!

Set P0151 and P0185 to the maximum value (800 V) when using dynamic braking.

The braking torque that can be obtained using frequency inverters without dynamic braking varies between 10 % to 35 % of the motor rated torque.

In order to obtain higher braking torques, resistors for dynamic braking must be used. In this case, the energy regenerated in excess is dissipated on a resistor mounted outside the inverter.

This type of braking is used in cases when short deceleration times are desired or when high inertia loads are driven.

For the vector control mode, there is the possibility of using the "Optimal Braking", eliminating in many cases the need of dynamic braking use.

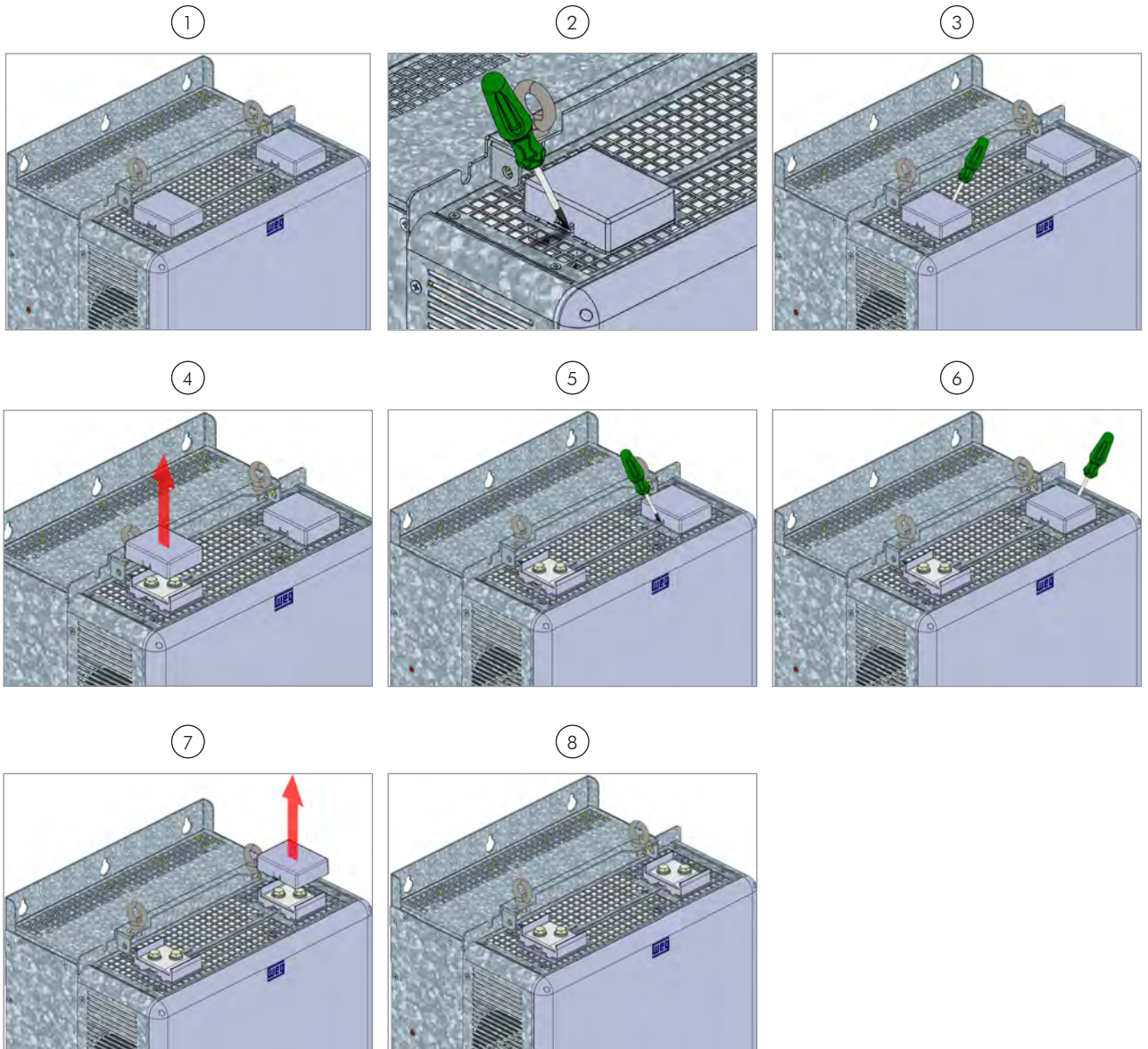

(a) Frame sizes F and G

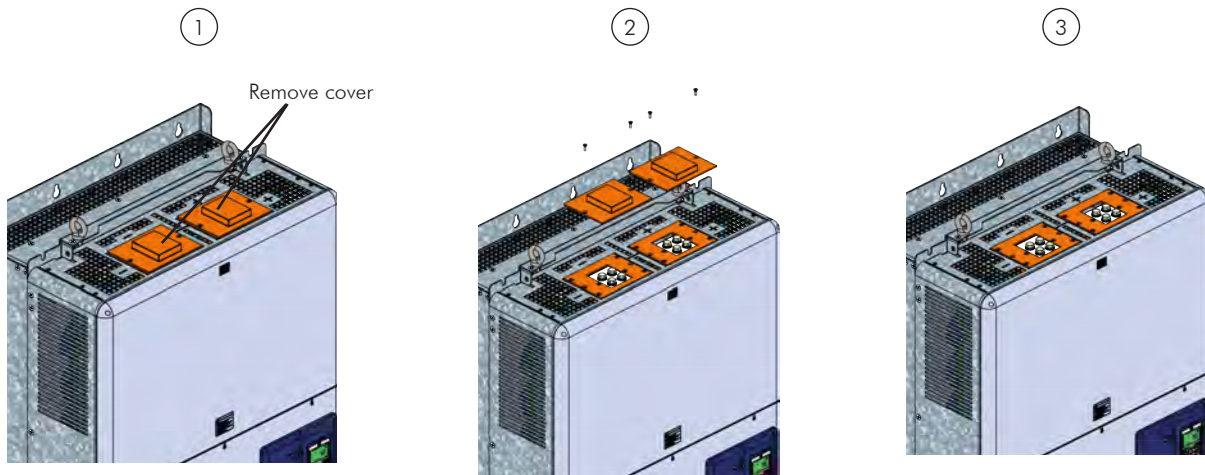

(b) Frame size H

Figure 3.13 - (a) and (b) - Sequence for the connection cables of DC+ and DC- for connection of an external braking module to CFW-11 inverter

3.2.3.3 Output Connections



ATTENTION!

The inverter has an electronic motor overload protection that must be adjusted according to the driven motor. When several motors are connected to the same inverter, install individual overload relays for each motor.



ATTENTION!

The motor overload protection available in the CFW-11 is in accordance with the IEC60947-4-2 and UL508C standards, note the following information:

- ☑ Trip current equal to 1.25 times the motor rated current (P0401) adjusted in the oriented start-up menu.
- ☑ The maximum value for P0398 (Motor Service Factor) is 1.15.
- ☑ Parameters P0156, P0157 and P0158 (Overload Current at 100 %, 50 % and 5 % of the rated speed, respectively) are automatically adjusted when parameters P0401 (Motor Rated Current) and/or P0406 (Motor Ventilation) are adjusted in the oriented start-up routine. If parameters P0156, P0157 and P0158 are manually adjusted, the maximum allowed value is $1.05 \times P0401$.



ATTENTION!

If a disconnect switch or a contactor is installed between the inverter and the motor, never operate it with a spinning motor or with voltage at the inverter output.

The characteristics of the cable used to connect the motor to the inverter, as well as its routing, are extremely important to avoid electromagnetic interference in other equipment and not to affect the life cycle of windings and bearings of the controlled motors.

Recommendations for motor cables:

Unshielded Cables:

- ☑ Can be used when it is not necessary to meet the European directive of electromagnetic compatibility (2014/30/EU).
- ☑ Keep motor cables away from other cables (signal cables, sensor cables, control cables, etc.), according to the [Table 3.6 on page 3-27](#).
- ☑ The emission of the cables may be reduced by installing them inside a metal conduit, which must be grounded at both ends.
- ☑ Connect a fourth cable between the motor ground and the inverter ground.



NOTE!

The magnetic field created by the current circulation in these cables may induce currents in nearby metal parts, heating them, and cause additional electrical losses. Therefore, keep the three cables (U, V, W) always together.

Shielded Cables:

- ☑ Are mandatory when the electromagnetic compatibility directive (2014/30/EU) has to be met, as defined by the standard EN 61800-3 "Adjustable Speed Electrical Power Drive Systems". These cables act mainly by reducing the irradiated emission in the radio-frequency range.
- ☑ Regarding to the types and installation details, follow the recommendations of IEC 60034-25 "Guide for Design and Performance of Cage Induction Motors Specifically Designed for Converter Supply", verify the summary in the [Figure 3.14 on page 3-28](#). Refer to the standard for further details and eventual modifications related to new revisions.
- ☑ Keep motor cables away from other cables (signal cables, sensor cables, control cables, etc.), according to the [Table 3.6 on page 3-27](#).
- ☑ The grounding system must be well interconnected among the several installation locations such as the grounding points of the motor and the inverter. Voltage difference or impedance between the several points may cause the circulation of parasite currents among the equipments connected to the ground, resulting in electromagnetic interference problems.

Table 3.6 - Minimum separation distance between motor cables and all other cables

Cable Length	Minimum Separation Distance
≤ 30 m (100 ft)	≥ 10 cm (3.94 in)
> 30 m (100 ft)	≥ 25 cm (9.84 in)

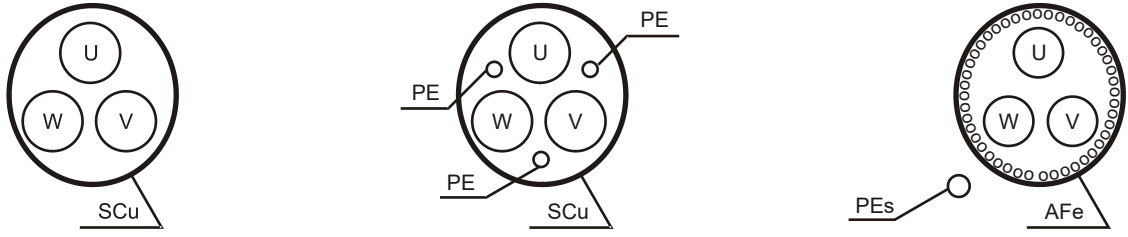

(a) Symmetrical shielded cables: three concentric conductors with or without a ground conductor, symmetrically manufactured, with an external shield of copper or aluminum

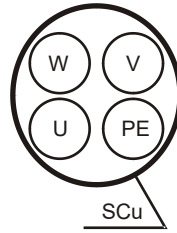

(b) Alternatives for conductors up to 10 mm²

- (1) SCu = copper or aluminum external shielding.
- (2) AFe = galvanized steel or iron.
- (3) PE = ground conductor.
- (4) Cable shielding must be grounded at both ends (inverter and motor). Use 360° connections for low impedance to high frequencies.
- (5) For using the shield as a protective ground, it must have at least 50 % of the power cables conductivity. Otherwise, add an external ground conductor and use the shield as an EMC protection.
- (6) Shielding conductivity at high frequencies must be at least 10 % of the phase power cable conductivity.

Figure 3.14 - (a) and (b) - Motor connection cables recommended by IEC 60034-25

3.2.4 Grounding Connections



DANGER!

Do not share the grounding wiring with other equipment that operate with high currents (e.g. high power motors, soldering machines, etc.). When installing several inverters, follow the procedures presented in Figure 3.15 on page 3-29 for the grounding connection.



DANGER!

Ne pas partager le câblage de mise à la terre avec d'autres équipements opérant avec des intensités élevées (par ex: moteurs haute puissance, postes de soudure, etc.). Lors de l'installation de plusieurs variateurs, appliquer les procédures présentées dans l'illustration Figure 3.15 à la page 3-29 pour la connexion de mise à la terre.



ATTENTION!

The neutral conductor of the network must be solidly grounded; however, this conductor must not be used to ground the inverter.



DANGER!

The inverter must be obligatorily connected to a protective ground (PE).

Observe the following:

- Use a minimum wire gauge for ground connection equal to the indicated in the [Table 3.2 on page 3-13](#) or [Table 3.3 on page 3-16](#). Conform to local regulations and/or electrical codes in case a different wire gauge is required.
- Connect the inverter grounding connections to a ground bus bar, to a single ground point, or to a common grounding point (impedance $\leq 10 \Omega$).
- To comply with IEC 61800-5-1 standard, connect the inverter to the ground by using a single conductor copper cable with a minimum wire gauge of 10 mm², since the leakage current is greater than 3.5 mA_{Ac}.



DANGER!

Le variateur doit être raccordé à une terre de protection (PE).

Observer les règles suivantes:

- Utilisez la section minimale de raccordement à la terre indiquée dans les [Table 3.2 à la page 3-13](#) or [Table 3.3 à la page 3-16](#). Se conformer aux à la réglementation locale et/ou aux codes de l'électricité si une autre épaisseur de fil est nécessaire.
- Connectez la masse du variateur à une barre collectrice de terre en un seul point ou à un point commun de raccordement à la terre (impédance $\leq 10 \Omega$).
- Pour assurer la conformité avec la norme CEI 61800-5-1, connecter le variateur à la terre grâce à un câble en cuivre à un conducteur ayant une épaisseur de fil minimale de 10 mm², étant donné que le courant de fuite est supérieur à 3,5 mA C.A.

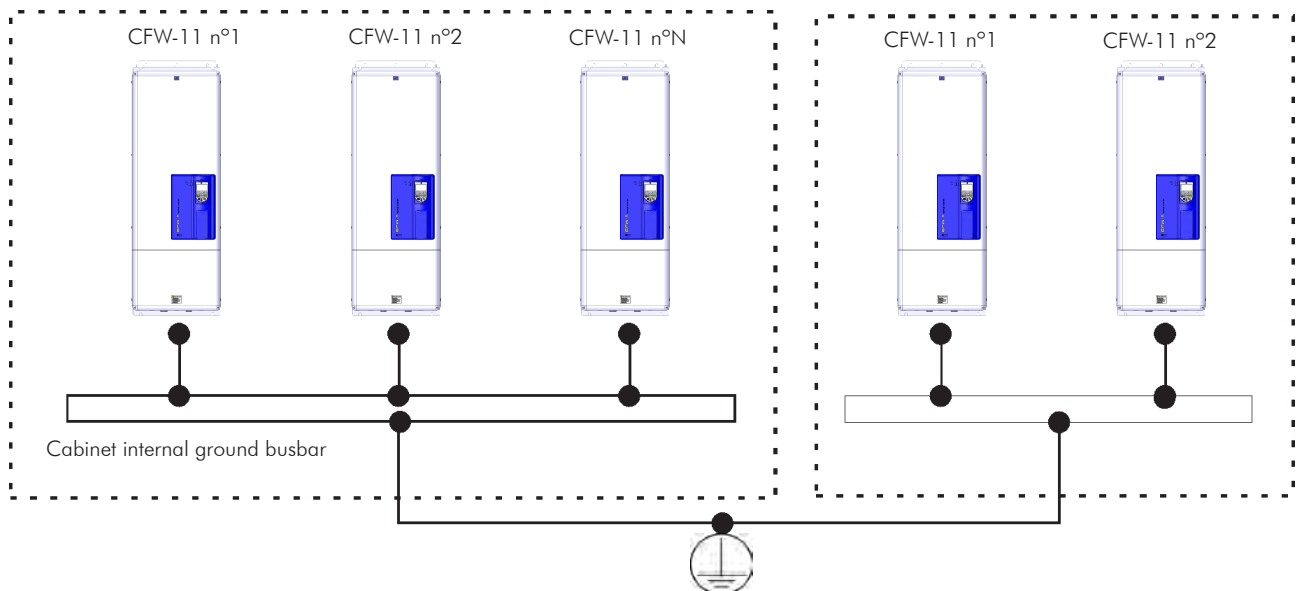

Figure 3.15 - Grounding connections with multiple inverters

3.2.5 Control Connections

The control connections (analog inputs/outputs, digital inputs/outputs), must be made at the CC11 control board terminal strip XC1.

Functions and typical connections are presented in Figure 3.16 on page 3-31.

XC1 Terminal Strip	Factory Setting Function	Specifications
1	+REF	Positive reference for potentiometer Output voltage: +5.4 V, ±5 % Maximum output current: 2 mA
2	AI1 +	Analog input 1: Speed reference (remote) Differential Resolution: 12 bits Signal: 0 to 10 V ($R_{IN} = 400\text{ k}\Omega$) / 0 to 20 mA / 4 to 20 mA ($R_{IN} = 500\ \Omega$) Maximum voltage: ±30 V
3	AI1 -	
4	REF-	Negative reference for potentiometer Output voltage: -4.7 V, ±5 % Maximum output current: 2 mA
5	AI2 +	Analog input 2: no function Differential Resolution: 11 bits + signal Signal: 0 to ±10 V ($R_{IN} = 400\text{ k}\Omega$) / 0 to 20 mA / 4 to 20 mA ($R_{IN} = 500\ \Omega$) Maximum voltage: ±30 V
6	AI2 -	
7	AO1	Analog output 1: speed Galvanic Isolation Resolution: 11 bits Signal: 0 to 10 V ($R_L \geq 10\text{ k}\Omega$) / 0 to 20 mA / 4 to 20 mA ($R_L \leq 500\ \Omega$) Protected against short-circuit
8	AGND (24 V)	Reference (0 V) for the analog outputs Connected to the ground (frame) through an impedance: 940 kΩ resistor in parallel with a 22 nF capacitor. Same reference as the one of DGND *
9	AO2	Analog output 2: motor current Galvanic isolation Resolution: 11 bits Signal: 0 to 10 V ($R_L \geq 10\text{ k}\Omega$) / 0 to 20 mA / 4 to 20 mA ($R_L \leq 500\ \Omega$) Protected against short-circuit
10	AGND (24 V)	Reference (0 V) for the analog outputs Connected to the ground (frame) through an impedance: 940 kΩ resistor in parallel with a 22 nF capacitor. Same reference as the one of DGND *
11	DGND*	Reference (0 V) for the 24 Vdc power supply Connected to the ground (frame) through an impedance: 940 kΩ resistor in parallel with a 22 nF capacitor. Same reference as the one of AGND (24 V)
12	COM	Common point of the digital inputs
13	24 Vdc	24 Vdc power supply 24 Vdc power supply, ±8 % Capacity: 500 mA Note: In the models with the 24 Vdc external control power supply (CFW11...O...W...) pin 13 of XC1 is considered as an input, that is, the user must provide a supply for the inverter (for further details refer to Item 7.1.2 24 Vdc External Control Power Supply on page 7-1). In all the other models this terminal is an output, i.e., the user has a 24 Vdc power supply available there
14	COM	Common point of the digital inputs
15	DI1	Digital input 1: Start/Stop 6 digital inputs galvanic insulated High level ≥ 18 V Low level ≤ 3 V Maximum input voltage = 30 V Input current: 11 mA @ 24 Vdc
16	DI2	Digital input 2: Direction of rotation (remote)
17	DI3	Digital input 3: no function
18	DI4	Digital input 4: no function
19	DI5	Digital input 5: Jog (remote)
20	DI6	Digital input 6: 2 nd ramp
21	NF1	Digital output 1 DO1 (RL1): No fault Contact rating: Maximum voltage: 240 Vac Maximum current: 2 A NF - normally closed contact C - common NA - normally open contact
22	C1	
23	NA1	
24	NF2	Digital output 2 DO2 (RL2): $N > N_x$ - speed > P0288
25	C2	
26	NA2	
27	NF3	Digital output 3 DO3 (RL3): $N^* > N_x$ - speed reference > P0288
28	C3	
29	NA3	

(a) Signals at connector XC1 - Digital inputs working as "active high"

XC1 Terminal Strip	Factory Setting Function	Specifications	
1	+REF	Positive reference for potentiometer	
2	AI1 +	Analog input 1: Speed reference (remote)	
3	AI1 -		
4	REF-	Negative reference for potentiometer	
5	AI2+	Analog input 2: no function	
6	AI2-		
7	AO1	Analog output 1: speed	
8	AGND (24 V)	Reference (0 V) for the analog outputs	
9	AO2	Analog output 2: motor current	
10	AGND (24 V)	Reference (0 V) for the analog outputs	
11	DGND*	Reference (0 V) for the 24 Vdc power supply	
12	COM	Common point of the digital inputs	
13	24 Vdc	24 Vdc power supply	
14	COM	Common point of the digital inputs	
15	DI1	Digital input 1: Start/Stop High level ≥ 18 V Low level ≤ 3 V Maximum input voltage = 30 V Input current: 11 mA @ 24 Vdc	
16	DI2		
17	DI3		
18	DI4		
19	DI5		
20	DI6		
21	NF1	Digital input 1 DO1 (RL1): no fault	
22	C1		
23	NA1		
24	NF2		Digital input 2 DO2 (RL2): $N > N_x$ - speed > P0288
25	C2		
26	NA2		
27	NF3		Digital input 3 DO3 (RL3): $N^* > N_x$ - speed reference > P0288
28	C3		
29	NA3		

(b) Digital inputs working as "active low"

Figure 3.16 - (a) and (b) - Signals at connector XC1



NOTE!

In order to use the digital inputs as active low, remove the jumper between XC1:11 and 12 and install it between XC1:12 and 13.

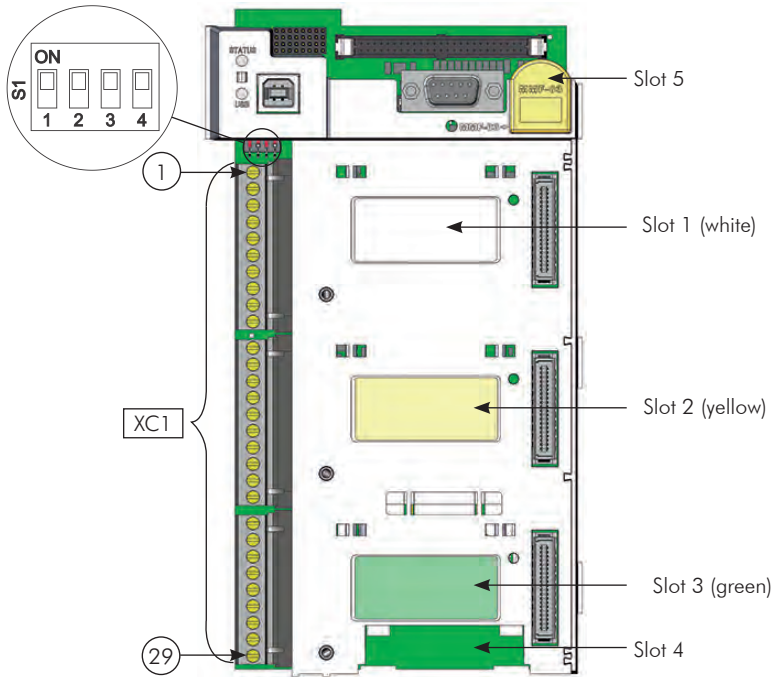

Figure 3.17 - XC1 terminal strip and DIP-switches for selecting the signal type of analog inputs and outputs

As the factory setting, the analog inputs and outputs are adjusted to operate in the 0 to 10 V range, but they can be changed by using the S1 DIP-switch.

Table 3.7 - Configuration of DIP-switches for selecting the signal type of analog inputs and outputs

Signal	Factory Setting Function	DIP Switch	Selection	Factory Setting
AI1	Speed reference (remote)	S1.4	OFF: 0 to 10 V (factory setting) ON: 4 to 20 mA / 0 to 20 mA	OFF
AI2	No function	S1.3	OFF: 0 to ±10 V (factory setting) ON: 4 to 20 mA / 0 to 20 mA	OFF
AO1	Speed	S1.1	OFF: 4 to 20 mA / 0 to 20 mA ON: 0 to 10 V (factory setting)	ON
AO2	Motor current	S1.2	OFF: 4 to 20 mA / 0 to 20 mA ON: 0 to 10 V (factory setting)	ON

Parameters related to the analog inputs and outputs (AI1, AI2, AO1, and AO2) must be programmed according to the DIP-switches settings and desired values.

Follow instructions below for the proper installation of the control wiring:

1. Wire gauge: 0.5 mm² (20 AWG) to 1.5 mm² (14 AWG).
2. Maximum tightening torque: 0.5 N.m (4.50 lbf.in).
3. Use shielded cables for the connections at XC1 and run the cables separated from the remaining circuits (power, 110 V / 220 Vac control, etc.), as presented in [Table 3.8 on page 3-34](#). If control cables must cross other cables, it must be done perpendicularly among them, keeping a minimum of 5 cm (1.9 in) distance at the crossing point.

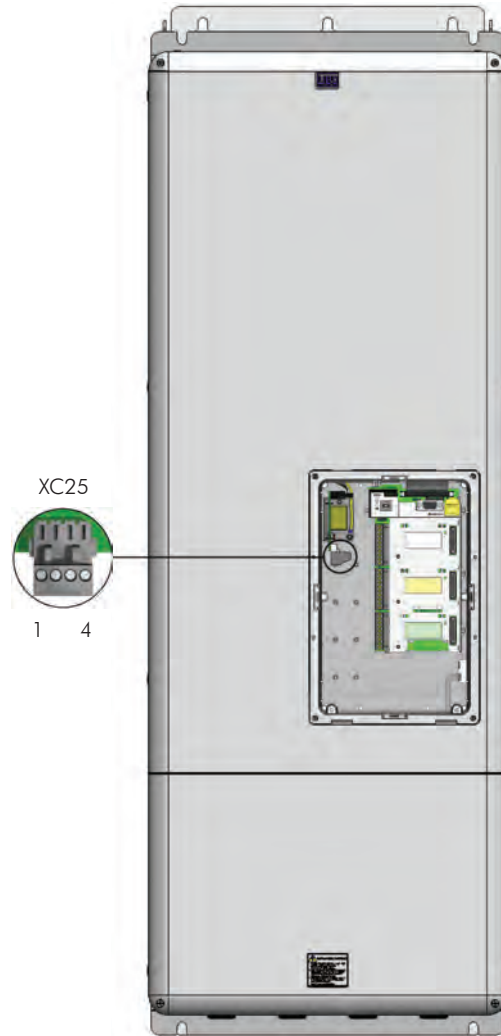

Frame sizes F, G and H inverters - SRB3.00 board

Figure 3.18 - SRBXX board connections (Safety Stop function)



NOTE!

Safety Stop function: the inverters with Safety Stop function option (CFW11...O...Y...) are supplied with control connections to disable Safety Stop function as per [Figure 3.19 on page 3-34](#). For using the Safety Stop function see [Section 3.3 SAFETY STOP FUNCTION on page 3-38](#).

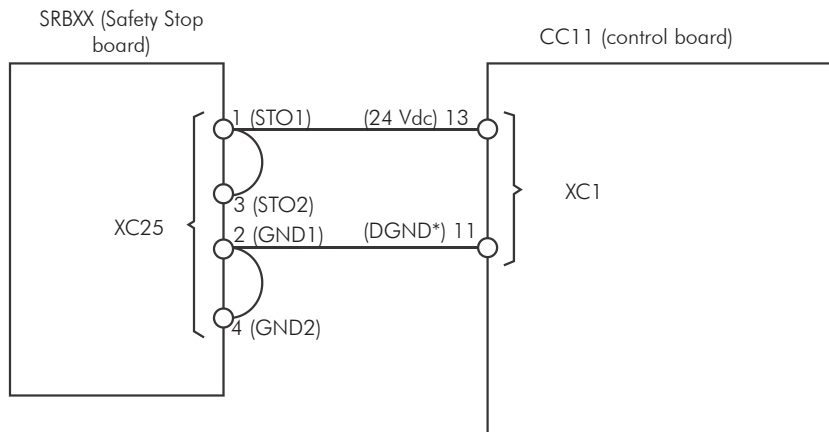

Figure 3.19 - Internal control connections to disable Safety Stop function

Table 3.8 - Minimum separation distances between wiring

Cable Length	Minimum Separation Distance
≤ 30 m (100 ft)	≥ 10 cm (3.94 in)
> 30 m (100 ft)	≥ 25 cm (3.94 in)

4. The correct connection of the cable shield is shown in [Figure 3.20 on page 3-34](#) and [Figure 3.21 on page 3-35](#).

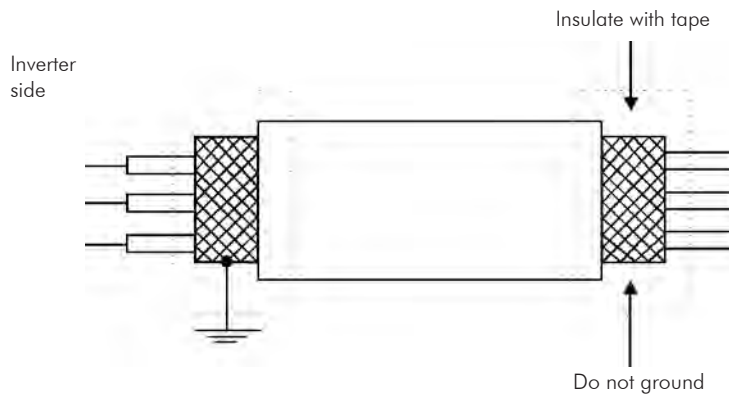

Figure 3.20 - Shield connection

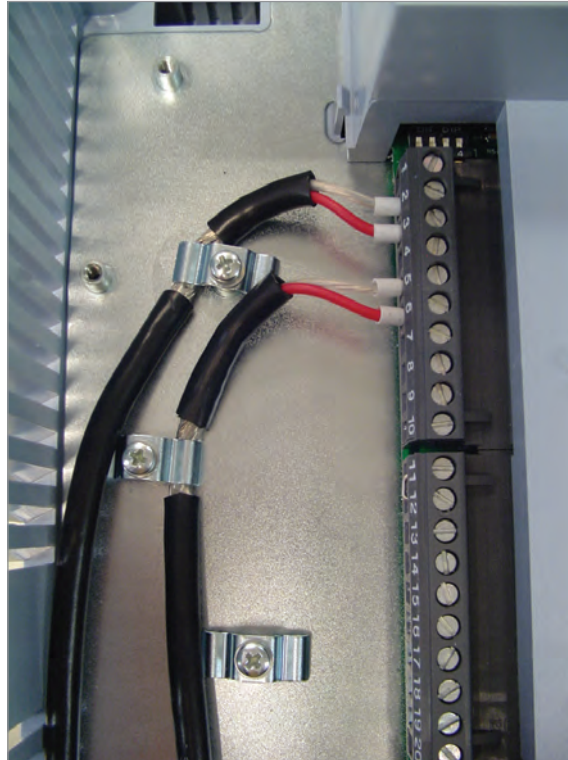

Figure 3.21 - Example of control wiring shield connection

5. Relays, contactors, solenoids or coils of electromechanical brakes installed close to the inverter may occasionally generate interferences in the control circuitry. To eliminate this effect, RC suppressors (with AC power supply) or freewheel diodes (with DC power supply) must be connected in parallel to the coils of these devices.

3.2.6 Typical Control Connections

Control connection 1 - Run/Stop function controlled from the keypad (Local Mode).



With this control connection, it is possible to run the inverter in local mode with the factory default settings.

This operation mode is recommended for first-time users, since no additional control connections are required.

For the start-up in this operation mode, please follow instructions listed in [Chapter 5 FIRST TIME POWER-UP AND START-UP](#) on page 5-1.

Control connection 2 - 2-Wire Run/Stop function (Remote Mode).

This wiring example is valid only for the default factory settings and if the inverter is set to remote mode.

With the factory default settings, the selection of the operation mode (local/remote) is performed through the HMI key  (local mode is default). Set P0220 = 3 to change the default setting of HMI key  to remote mode.

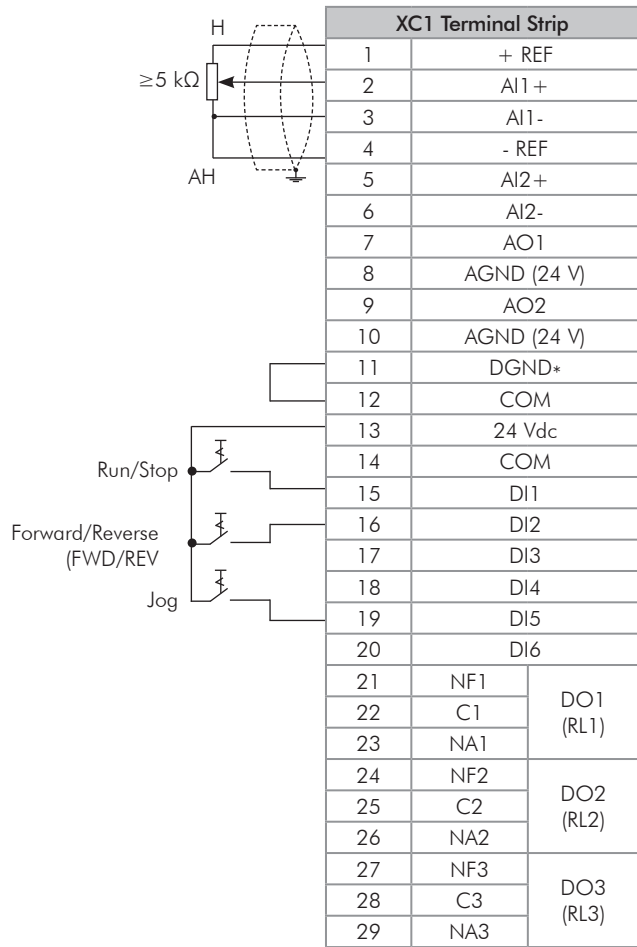

Figure 3.22 - XC1 wiring for control connection 2

Control connection 3 - 3-Wire Start/Stop function.

Enabling the Run/Stop function with 3-wire control.

Parameters to set:

Set DI3 to START.

P0265 = 6.

Set DI4 to STOP.

P0266 = 7.

Set P0224 = 1 (DIx) for 3-wire control in Local mode.

Set P0227 = 1 (DIx) for 3-wire control in Remote mode.

Set the Forward/Reverse selection by using digital input 2 (DI2).

Set P0223 = 4 for Local Mode or P0226 = 4 for Remote Mode.

S1 and S2 are Start (NO contact) and Stop (NC contact) pushbuttons respectively.

The speed reference can be provided through the analog input (as in control connection # 2), through the keypad (as in control connection # 1) or through other available source.

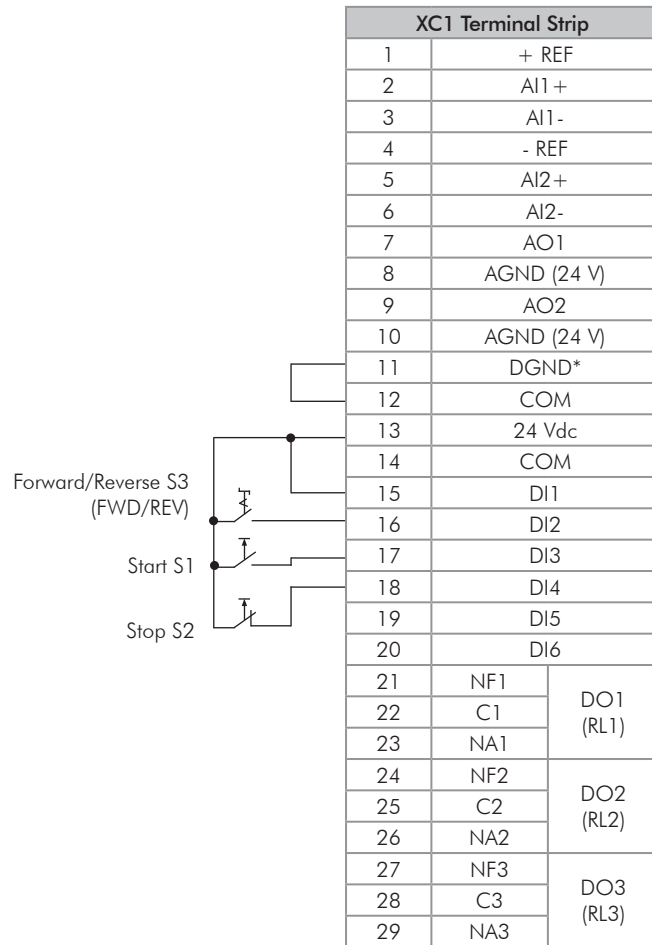

Figure 3.23 - XC1 wiring for control connection 3

Control connection 4 - Forward/Reverse.

Enabling the Forward/Reverse function.



Parameters to set:

Set DI3 to FORWARD RUN.

P0265 = 4.

Set DI4 to REVERSE RUN.

P0266 = 5.

When the Forward/Reverse function is set, it will be active either in Local or Remote mode. At the same time, the HMI keys  and  will remain always inactive (even if P0224 = 0 or P0227 = 0).

The direction of rotation is determined by the Forward run and Reverse run inputs.

Clockwise direction for Forward run and counterclockwise for Reverse run.

The speed reference can be provided by any source (as in the Control connection 3).

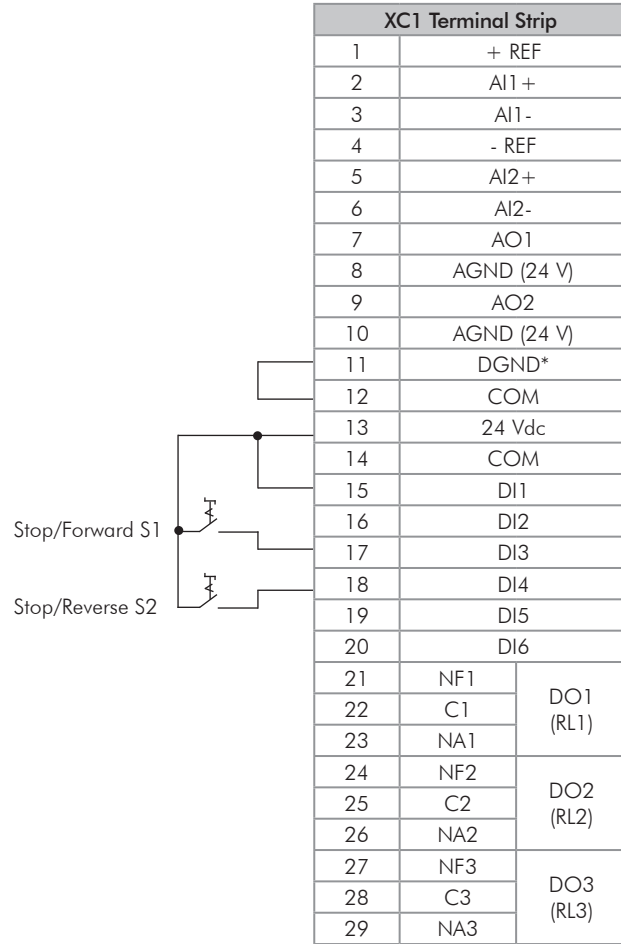

Figure 3.24 - XC1 wiring for control connection 4

3.3 SAFETY STOP FUNCTION

Frequency inverters that have the optional SRBXX board implement the STO (Safe Torque Off) safety function. For detailed information, refer to the Safety Stop Function Installation, Configuration and Operation Guide.

3.4 INSTALLATION ACCORDING TO THE EUROPEAN DIRECTIVE OF ELECTROMAGNETIC COMPATIBILITY

The CFW-11 inverters with frame sizes F, G and H feature internal RFI filter to reduce the electromagnetic interference.

These inverters, when properly installed, meet the requirements of the electromagnetic compatibility directive "EMC Directive 2014/30/EU".

The CFW-11 inverter series has been designed only for industrial applications. Therefore, the emission limits of harmonic currents defined by the standards EN 61000-3-2 and EN 61000-3-2/A14 are not applicable.



ATTENTION! For using models with internal RFI filters in IT networks follow the instructions on [Item 3.2.3.1.2 IT Networks on page 3-23](#).

3.4.1 Conformal Installation

For the conformal installation use:

1. Shielded output cables (motor cables) with the shield connected at both ends, motor and inverter, by means of a low impedance to high frequencies connection.

Keep the separation distance to the other cables according to the [Table 3.6 on page 3-27](#) indication refer to [Item 3.2.3 Power Connections on page 3-19](#), for more information.

Maximum motor cable length and conducted and radiated emission levels according to the [Table 3.9 on page 3-40](#).

If a lower conducted emission level category is wished, then an external RFI filter must be used at the inverter input. For more information (RFI filter commercial reference, motor cable length and emission levels) refer to the [Table 3.9 on page 3-40](#).

2. Shielded control cables, keeping the separation distance to other cables according to the [Item 3.2.5 Control Connections on page 3-30](#).
3. Inverter grounding according to the [Item 3.2.4 Grounding Connections on page 3-28](#).

3.4.2 Standard Definitions

IEC/EN 61800-3: "Adjustable Speed Electrical Power Drives Systems"

- Environment:

First Environment: includes domestic premises, it also includes establishments directly connected without intermediate transformer to a low-voltage power supply network which supplies buildings used for domestic purposes.

Example: houses, apartments, commercial installations, or offices located in residential buildings.

Second Environment: includes all establishments other than those directly connected to a low-voltage power supply network which supplies buildings used for domestic purposes.

Example: industrial area, technical area of any building supplied by a dedicated transformer.

- Categories:

Category C1: inverters with a voltage rating less than 1000 V and intended for use in the First Environment.

Category C2: inverters with a voltage rating less than 1000 V, intended for use in the First Environment, not provided with a plug connector or a movable installations, and installed and commissioned by a professional.

Note: a professional is a person or organization familiar with the installation and/or commissioning of inverters, including the EMC aspects.

Category C3: inverters with a voltage rating less than 1000 V and intended for use in the Second Environment only (not designed for use in the First Environment).

Category C4: inverters with a voltage rating equal to or greater than 1000 V, or with a current rating equal to or greater than 400 Amps, or intended for use in complex systems in the Second Environment.

EN 55011: "Threshold values and measuring methods for radio interference from industrial, scientific and medical (ISM) high-frequency equipment"

Class B: equipment intended for use in the low-voltage power supply network (residential, commercial, and light-industrial environments).

Class A1: equipment intended for use in the low-voltage power supply network. Restricted distribution.

Note: must be installed and commissioned by a professional when applied in the low-voltage power supply network.

Class A2: equipment intended for use in industrial environments.

3

3.4.3 Emission and Immunity Levels

Table 3.9 - Emission and immunity levels

EMC Phenomenon	Basic Standard	Level
Emission:		
Mains terminal disturbance voltage Frequency range: 150 kHz to 30 MHz	IEC/EN61800-3 (2004) + A1 (2011)	It depends on the inverter model and on the motor cable length. Refer to Table 3.10 on page 3-41
Electromagnetic radiation disturbance Frequency range: 30 MHz to 1000 MHz		
Immunity:		
Electrostatic discharge (ESD)	IEC 61000-4-2 (2008)	4 kV for contact discharge and 8 kV for air discharge
Fast transient-burst	IEC 61000-4-4 (2012)	2 kV / 5 kHz (coupling capacitor) power input cables 1 kV / 5 kHz control cables, and remote keypad cables 2 kV / 5 kHz (coupling capacitor) motor output cables
Conducted radio-frequency common mode	IEC 61000-4-6 (2013)	0,15 to 80 MHz; 10 V; 80 % AM (1 kHz) Motor cables, control cables, and remote keypad cables
Surge immunity	IEC 61000-4-5 (2014)	1,2/50 μ s, 8/20 μ s 1 kV line-to-line coupling 2 kV line-to-ground coupling
Radio-frequency electromagnetic field	IEC 61000-4-3 (2010)	80 MHz to 1000 GHz 10 V/m 1,4 GHz to 2GHz 3 V/m 2 GHz to 2,7 GHz 1 V/m 80 % AM (1 kHz)

Table 3.10 - Conducted and radiated emission levels

Inverter Model	Without External RFI Filter		With External RFI Filter		
	Conducted Emission - Maximum Motor Cable Length	Radiated Emission	External RFI Filter Part Number (Manufacturer Epcos)	Conducted Emission - Maximum Motor Cable Length	Radiated Emission
	Category C3	Category without Metallic Cabinet		Category C2	Category with Metallic Cabinet
CFW110242T4	100 m	C3 ⁽¹⁾	B84143-B0250-S020	50 m ⁽³⁾	C3
CFW110312T4	100 m	C3 ⁽¹⁾	B84143-B0320-S020	50 m ⁽³⁾	C3
CFW110370T4	100 m	C3 ⁽¹⁾	B84143-B0400-S020	50 m ⁽³⁾	C3
CFW110477T4	100 m	C3 ⁽¹⁾	B84143-B0600-S020	50 m ⁽³⁾	C3
CFW110515T4	100 m	C3 ⁽¹⁾	B84143-B0600-S020	50 m ⁽³⁾	C3
CFW110601T4	100 m	C3 ⁽¹⁾	B84143-B0600-S020	50 m ⁽³⁾	C3
CFW110720T4	100 m	C3 ⁽¹⁾	B84143-B1000-S020	50 m ⁽³⁾	C3
CFW110760T4	100 m	C4 ⁽²⁾	B84143-B1000-S020	-	-
CFW110795T4	100 m	C4 ⁽²⁾	B84143-B1000-S80	-	-
CFW110877T4	100 m	C4 ⁽²⁾		-	-
CFW111062T4	100 m	C4 ⁽²⁾	B84143-B1250-S80	-	-
CFW111141T4	100 m	C4 ⁽²⁾		-	-

(1) With toroidal core in the three line power supply cables (the three cables connected to R/L1, S/L2 and T/L3 must pass through a single toroidal core). Example: TDK PN: PC40U120x160x20 ironclube PN: U126x91x20-3F3. If the installation of the inverter is done inside the cabinet with attenuation of 10 dB in the frequency range [30; 50] MHz, the toroidal core is not necessary.

(2) For further details, contact WEG.

(3) Minimum operating frequency of 2.5 Hz.

4 HMI

This chapter contains the following information:

- ☑ HMI keys and their functions.
- ☑ Display indications.
- ☑ Parameter structure.



4.1 INTEGRAL KEYPAD - HMI-CFW-11

The integral keypad can be used to operate and program (view / edit all parameters) of the CFW-11 inverter.

The inverter keypad navigation is similar to the one used in cell phones and the parameters can be accessed in numerical order or through groups (Menu).

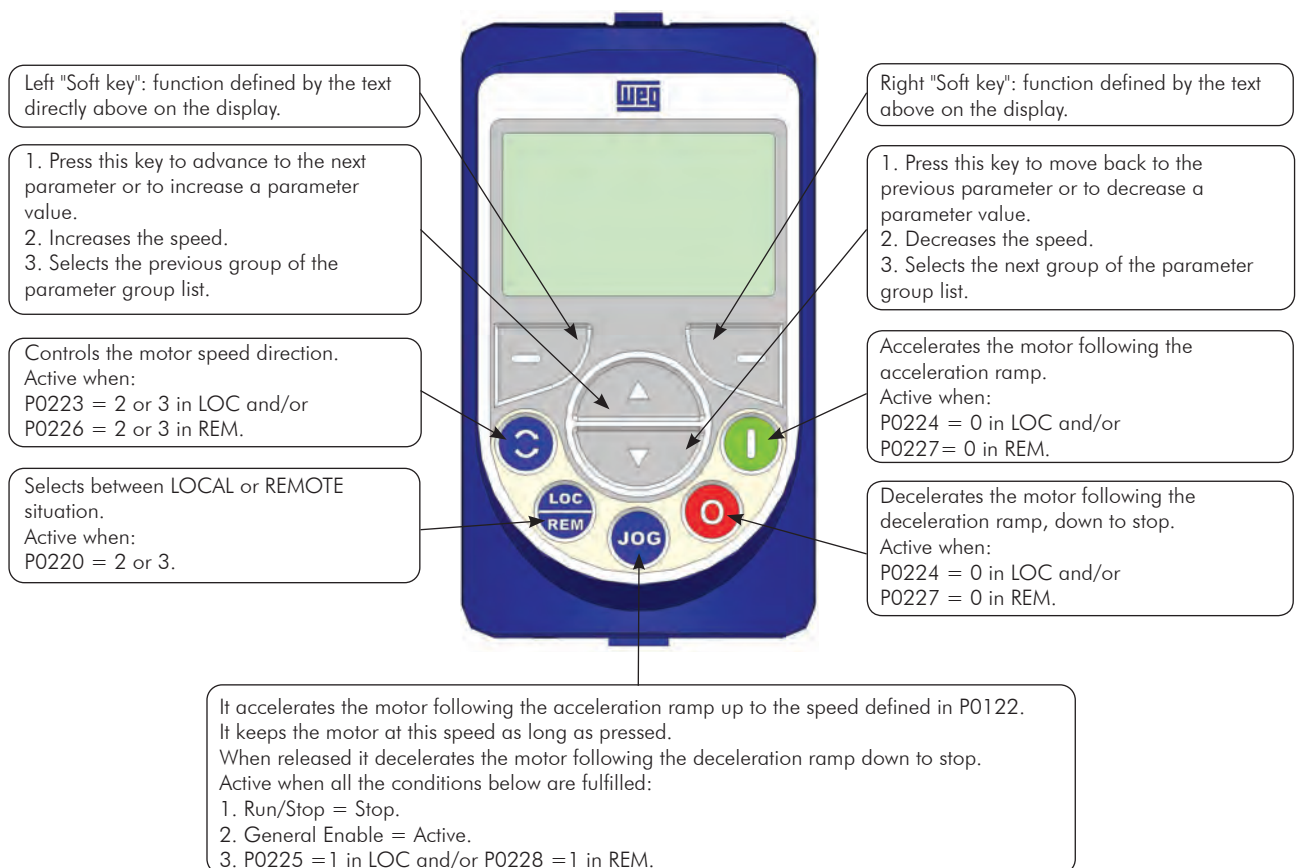

Figure 4.1 - HMI keys

Battery:



NOTE!

The battery is necessary only to keep the internal clock operation when the inverter stays without power. If the battery is completely discharged or if it is not installed in the keypad, the displayed clock time will be invalid and an alarm condition "A181 - Invalid clock time" will be indicated every time the inverter is powered up.

The life expectation of the battery is of approximately 10 years. When necessary, replace the battery by another of the CR2032 type.



Location of the battery access cover



Press the cover and rotate it counterclockwise



Remove the cover



Remove the battery with the help of a screwdriver positioned at the right side



HMI without the battery



Install the new battery positioning it first at the left side



Press the battery for its insertion



Put the cover back and rotate it clockwise

Figure 4.2 - HMI battery replacement

**NOTE!**

At the end of the battery useful life, please do not discard batteries in your waste container, but use a battery disposal site.

Installation:

- ☑ The keypad can be installed or removed from the inverter with or without AC power applied to it.
- ☑ The HMI supplied with the product can also be used for remote command of the inverter. In this case, use a cable with male and female D-Sub9 (DB-9) connectors wired pin to pin (mouse extension type) or a market standard Null-Modem cable. Maximum length of 10 m (33 ft). It is recommended the use of the M3 x 5.8 standoffs supplied with the product. Recommended torque: 0.5 N.m (4.50 lbf.in).

When the inverter is energized, the display goes into the monitoring mode. For the factory setting, the screen similar to [Figure 4.3 on page 4-4](#) will be displayed. By setting proper parameters, other variables can be shown in the monitoring mode or the content of the parameters can be presented as bar graphs or larger characters as shown in [Figure 4.3 on page 4-4](#).

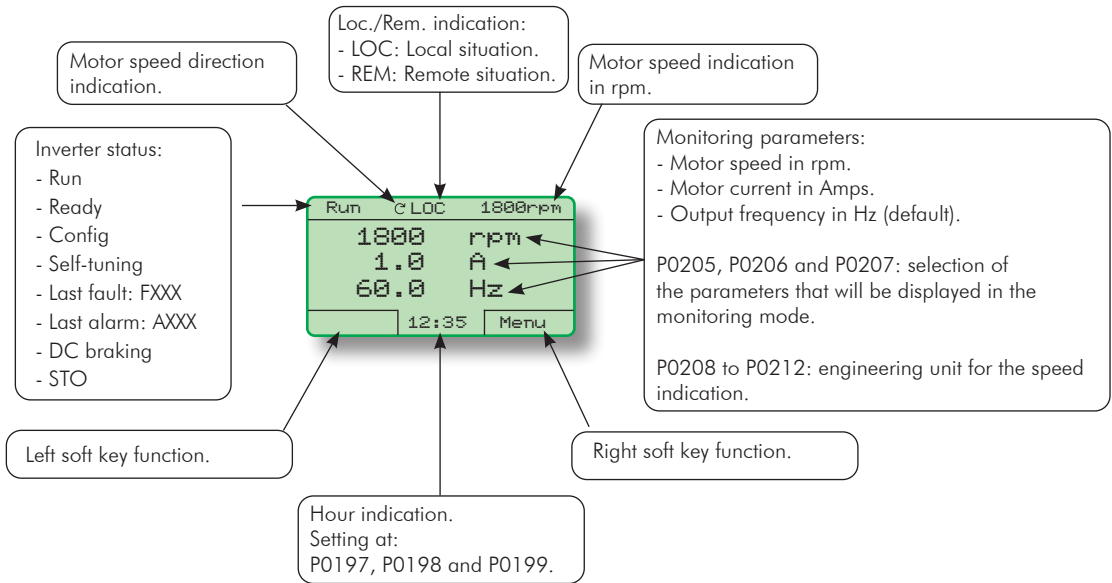

(a) Monitoring screen with the factory default settings

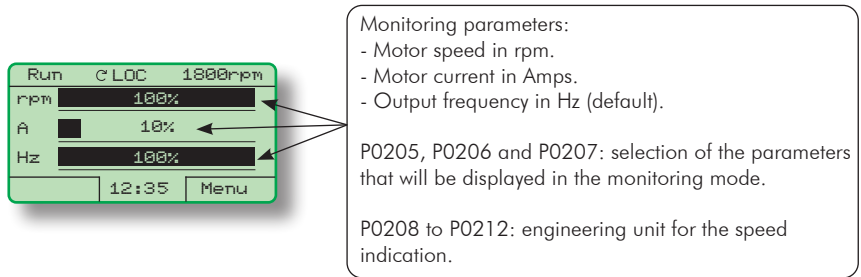

(b) Example of a monitoring screen with bar graphs

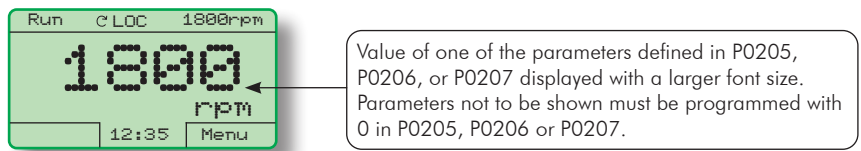

(c) Example of a monitoring screen displaying a parameter with a larger font size

Figure 4.3 - (a) to (c) - Keypad monitoring modes

4.2 PARAMETER STRUCTURE

When the right soft key ("MENU") is pressed in the monitoring mode, the display shows the first 4 groups of parameters. An example of how the groups of parameters are organized is presented in [Table 4.1 on page 4-5](#). The number and name of the groups may change depending on the firmware version used. For further details on the existent groups for the used firmware version, refer to the programming manual.

Table 4.1 - Groups of parameters

Level 0	Level 1	Level 2	Level 3			
Monitoring	00	ALL PARAMETERS				
	01	PARAMETER GROUPS	20	Ramps		
			21	Speed References		
			22	Speed Limits		
			23	V/f Control		
			24	Adjust. V/f Curve		
			25	VVW Control		
			26	V/f Current Limit.		
			27	V/f DC Volt. Limit.		
			28	Dynamic Braking		
			29	Vector Control	90	Speed Regulator
					91	Current Regulator
					92	Current Regulator
					93	I/F Control
					94	Self-Tuning
					95	Torque Curr. Limit.
					96	DC Link Regulator
					30	HMI
					31	Local Command
					32	Remote Command
					33	3-Wire Command
					34	FWD/REV Run Comm.
					35	Zero Speed Logic
					36	Multispeed
					37	Electr. Potentiom.
					38	Analog Inputs
					39	Analog Outputs
					40	Digital Inputs
					41	Digital Outputs
					42	Inverter Data
					43	Motor Data
					44	FlyStart/Ride-Thru
					45	Protections
			46	PID Regulator		
			47	DC Braking		
			48	Skip Speed		
			49	Communication	110	Local/Rem Config.
					111	Status/Commands
					112	CANopen/DeviceNet
					113	Serial RS-232/485
					114	Anybus
					115	Profibus DP
			50	SoftPLC		
			51	PLC		
			52	Trace Function		
		02	ORIENTED START-UP			
		03	CHANGED PARAMETERS			
	04	BASIC APPLICATION				
	05	SELF-TUNING				
	06	BACKUP PARAMETERS				
	07	I/O CONFIGURATION	38	Analog Inputs		
			39	Analog Outputs		
			40	Digital Inputs		
			41	Digital Outputs		
	08	FAULT HISTORY				
	09	READ ONLY PARAMS				

5 FIRST TIME POWER-UP AND START-UP

This chapter describes how to:

- Check and prepare the inverter before power-up.
- Power-up the inverter and check the result.
- Set the inverter for the operation in the V/f mode based on the power supply and motor information by using the Oriented Start-Up routine and the Basic Application group.

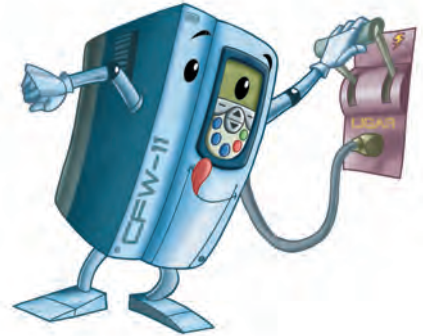

NOTE!

In order to use the inverter in VVW or vector control modes, and for other available functions, refer to the CFW-11 programming manual.



ATTENTION!

Firmware version V5.00 or higher **CANNOT** be used on inverters with control board revision prior to "D".

Any firmware version prior to V5.00 **CANNOT** be used on inverters with control board revision "D" or higher.

5.1 START-UP PREPARATION

The inverter must have been already installed according to the recommendations listed in [Chapter 3 INSTALLATION AND CONNECTION on page 3-1](#). The following recommendations are applicable even if the application design is different from the suggested control connections.



DANGER!

Always disconnect the main power supply before performing any inverter connection.



DANGER!

Débranchez toujours l'alimentation principale avant d'effectuer une connexion sur le variateur.

1. Check if power, grounding, and control connections are correct and firmly secured.
2. Remove from inside the inverter or the cabinet all the materials left behind from the installation work.
3. Verify the motor connections and if its voltage and current are within the inverter rated values.
4. Mechanically uncouple the motor from the load:
If the motor cannot be uncoupled, make sure that any speed direction (forward or reverse) will not result in personnel injury and/or equipment damage.
5. Close the inverter or cabinet covers.

6. Measure the power supply voltage and verify if it is within the allowed range, according to the [Chapter 8 TECHNICAL SPECIFICATIONS](#) on page 8-1.
7. Apply power to the input:
Close the input disconnect switch.
8. Check the result of the first time power-up:
The keypad should display the standard monitoring mode ([Figure 4.3 on page 4-4](#)), and the status LED should be steady green.

5.2 START-UP

The start-up procedure for the V/f is described in three simple steps by using the **Oriented Start-up** routine and the **Basic Application** group.

Steps:

1. Set the password for parameter modification.
2. Execute the **Oriented Start-up** routine.
3. Set the parameters of the **Basic Application** group.

5.2.1 P0000 Password Setting

Step	Action/Result	Display Indication
1	- Monitoring mode - Press "Menu" (right soft key)	
2	- The group "00 ALL PARAMETERS" is already selected - Press "Select"	
3	- The parameter "Access to Parameters P0000: 0" is already selected - Press "Select"	
4	- In order to set the password, press until the number 5 appears on the display	
5	- When the number 5 appears, press "Save"	
6	- If the setting was performed correctly, the display must show "Access to Parameters P0000: 5" - Press "Return" (left soft key)	
7	- Press "Return"	
8	- The display returns to the monitoring mode	

Figure 5.1 - Steps for allowing parameter modification via P0000

5.2.2 Oriented Start-Up

There is a group of parameters named "Oriented Start-up", which makes the inverter settings easier. The parameter P0317 from this group allows entering the Oriented Start-up routine.

The Oriented Start-Up routine presents the main parameters on the HMI in a logical sequence, so that their setting, according to the operation conditions, prepares the inverter for the operation with the used line and motor.

In order to enter an Oriented Start-up routine, follow the sequence presented in [Figure 5.2 on page 5-5](#), first changing P0317 = 1, and then setting the other parameters as they are displayed on the HMI.

First Time Power-Up and Start-Up

Setting the parameters in the Oriented Start-Up routine causes the automatic content modification of the other parameters and/or internal inverter variables.

During the Oriented Start-up routine, the message "Config" will be displayed at the top left corner of the HMI display.

Step	Action/Result	Display Indication	Step	Action/Result	Display Indication
1	- Monitoring mode - Press "Menu" (right soft key)		2	- The group "00 ALL PARAMETERS" is already selected 	
3	The group "01 PARAMETER GROUPS" is selected 		4	- The group "02 ORIENTED START-UP" is then selected - Press "Select"	
5	- The parameter "Oriented Start-up P0317: No" is already selected - Press "Select"		6	- The content of "P0317 = [000] No" is showed 	
7	- The content of the parameter is changed to "P0317 = [001] Yes" - Press "Save"		8	- At that moment the Oriented Start-up routine is initiated and the "Config" status is indicated at the top left corner of the HMI - The parameter "Language P0201: English" is already selected - If necessary, change the language by pressing "Select", next or to select the language and then press "Save" 	
9	- If necessary, change the value of P0202 according to the type of control. To do so, press "Select" - The settings listed here are valid only for P0202=0 (V/f 60 Hz) or P0202=1 (V/f 50 Hz). For other options (Adjustable V/f, VVW, or Vector modes), please refer to the programming manual 		10	- If necessary, change the value of P0296 according to the line rated voltage To do so, press "Select" This modification will affect P0151, P0153, P0185, P0321, P0322, P0323, and P0400 	
11	- If necessary, change the value of P0298 according to the inverter application To do so, press "Select" This modification will affect P0156, P0157, P0158, P0401, P0404 and P0410 (this last one only if P0202 = 0, 1, or 2 - V/f control). The time and the activation level of the overload protection will be affected as well 		12	- If necessary, change the value of P0398 according to the motor service factor To do so, press "Select" This modification will affect the current value and the activation time of the motor overload function 	











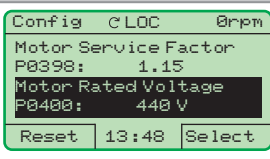

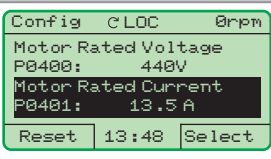
Step	Action/Result	Display Indication	Step	Action/Result	Display Indication
13	- If necessary, change the value of P0400 according to the motor rated voltage. To do so, press "Select". This modification adjusts the output voltage by a factor $x = P0400/P0296$ 		14	- If necessary, change the value of P0401 according to the motor rated current. To do so, press "Select". This modification will affect P0156, P0157, P0158, and P0410 	
15	- If necessary, set P0402 according to the motor rated speed. To do so, press "Select". This modification affects P0122 to P0131, P0133, P0134, P0135, P0182, P0208, P0288, and P0289 		16	- If necessary, set P0403 according to the motor rated frequency. To do so, press "Select". This modification affects P0402 	
17	- If necessary, change the value of P0404 according to the motor rated power. To do so, press "Select". This modification affects P0410 		18	- This parameter will only be visible if the encoder board ENC1 is installed in the inverter. - If there is an encoder connected to the motor, set P0405 according to the encoder pulses number. To do so, press "Select" 	
19	- If necessary, set P0406 according to the motor ventilation. To do so, press "Select". - To complete the Oriented Start-Up routine, press "Reset" (left soft key) or 		20	- After few seconds, the display returns to the monitoring mode	

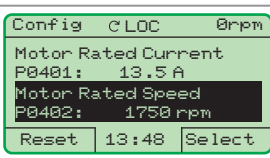
Figure 5.2 - Oriented Start-up

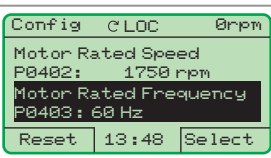
5.2.3 Basic Application Parameter Settings

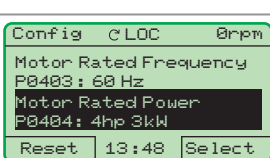
After running the Oriented Start-up routine and properly setting the parameters, the inverter is ready to operate in the V/f mode.

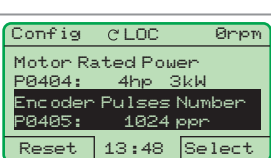
The inverter has a number of other parameters that allow its adaptation to the most different applications. This manual presents some basic parameters, whose setting is necessary in the majority of cases. To make this task easier, there is a group named Basic Application. A summary of the parameters contained in this group is presented in the [Table 5.1 on page 5-7](#). Also a group of read-only parameters shows the value of the most important inverter variables such as voltage, current, etc. The main parameters contained in this group are listed in [Table 5.2 on page 5-8](#). For further details, refer to the CFW-11 programming manual.

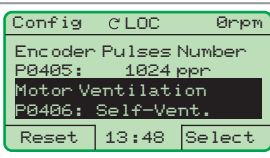
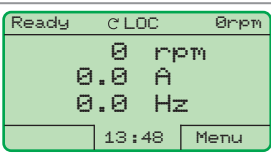
Follow steps outlined in [Figure 5.3 on page 5-6](#) to set the parameters of the Basic Application group.

The procedure for start-up in the V/f operation mode is finished after setting these parameters.

First Time Power-Up and Start-Up

Step	Action/Result	Display Indication	Step	Action/Result	Display Indication
1	- Monitoring mode - Press "Menu" (right soft key)		2	- Group "00 ALL PARAMETERS" is then selected 	
3	- Group "01 PARAMETER GROUPS" is then selected 		4	- Group "02 ORIENTED START-UP" is then selected 	
5	- Group "03 CHANGED PARAMETERS" is selected 		6	- Group "04 BASIC APPLICATION" is selected - Press "Select"	
7	- Parameter "Acceleration Time P0100: 20.0 s" has been already selected - If necessary, set P0100 according to the desired acceleration time. To do so, press "Select" - Proceed similarly until all parameters of group "04 BASIC APPLICATION" have been set. When finished, press "Return" (left soft key)		8	- Press "Return"	
9	- The display returns to the monitoring mode and the inverter is ready to operate				

Figure 5.3 - Setting parameters of the basic application group

Table 5.1 - Parameters contained in the basic application group

Parameter	Name	Description	Adjustable Range	Factory Setting	User Setting														
P0100	Acceleration Time	- It defines the time to accelerate linearly from 0 up to the maximum speed (P0134) - If set to 0.0 s, it means no acceleration ramp	0.0 to 999.0 s	20.0 s															
P0101	Deceleration Time	- It defines the time to decelerate linearly from the maximum speed (P0134) up to 0 - If set to 0.0 s, it means no deceleration ramp	0.0 to 999.0 s	20.0 s															
P0133	Minimum Speed	- They defines the minimum and the maximum values of the speed reference when the drive is enabled - These values are valid for any reference source	0 to 18000 rpm	90 rpm (60 Hz motor) 75 rpm (50 Hz motor)															
P0134	Maximum Speed			1800 rpm (motor 60 Hz) 1500 rpm (motor 50 Hz)															
		 <table border="1" data-bbox="606 784 845 907"> <tr> <td>0</td> <td>..... 10 V</td> </tr> <tr> <td>0</td> <td>..... 20 mA</td> </tr> <tr> <td>4 mA</td> <td>..... 20 mA</td> </tr> <tr> <td>10 V</td> <td>..... 0</td> </tr> <tr> <td>20 mA</td> <td>..... 0</td> </tr> <tr> <td>20 mA</td> <td>..... 4 mA</td> </tr> </table>		0 10 V	0 20 mA	4 mA 20 mA	10 V 0	20 mA 0	20 mA 4 mA				
0 10 V																		
0 20 mA																		
4 mA 20 mA																		
10 V 0																		
20 mA 0																		
20 mA 4 mA																		
P0135	Max. Output Current (V/f control mode current limitation)	- It avoids motor stalling under torque overload condition during the acceleration or deceleration - The factory default setting is for "Ramp Hold": if the motor current exceeds the value set at P0135 during the acceleration or deceleration, the motor speed will not be increased (acceleration) or decreased (deceleration) anymore. When the motor current reaches a value below the programmed in P0135, the motor speed is again increased or decreased - Other options for the current limitation are available. Refer to the CFW-11 programming manual	$0.2 \times I_{nom-HD}$ to $2 \times I_{nom-HD}$	$1.5 \times I_{nom-HD}$															
																			
P0136	Manual Torque Boost	- It operates in low speeds, modifying the output voltage x frequency curve to keep the torque constant - It compensates the voltage drop at the motor stator resistance. This function operates in low speeds increasing the inverter output voltage to keep the torque constant in the V/f mode - The optimal setting is the smallest value of P0136 that allows the motor to start satisfactorily. An excessive value will considerably increase the motor current at low speeds, and may result in a fault (F048, F051, F071, F072, F078 or F183) or alarm (A046, A047, A050 or A110) condition	0 to 9	1															
																			

Table 5.2 - Main read only parameters

Parameter	Description	Adjustable Range
P0001	Speed Reference	0 to 18000 rpm
P0002	Motor Speed	0 to 18000 rpm
P0003	Motor Current	0.0 to 4500.0 A
P0004	DC Link Voltage (Ud)	0 to 2000 V
P0005	Motor Frequency	0.0 to 1020.0 Hz
P0006	VFD Status	0 = Ready 1 = Run 2 = Undervoltage 3 = Fault 4 = Self-tuning 5 = Configuration 6 = DC-Braking 7 = STO
P0007	Motor Voltage	0 to 2000 V
P0009	Motor Torque	-1000.0 to 1000.0 %
P0010	Output Power	0.0 to 6553.5 kW
P0012	D18 to D11 Status	0000h to 00FFh
P0013	DO5 to DO1 Status	0000h to 001FL
P0018	AI1 Value	-100.00 to 100.00 %
P0019	AI2 Value	-100.00 to 100.00 %
P0020	AI3 Value	-100.00 to 100.00 %
P0021	AI4 Value	-100.00 to 100.00 %
P0023	Software Version	0.00 to 655.35
P0027	Accessories Config. 1	Hexadecimal code representing the identified accessories
P0028	Accessories Config. 2	Hexadecimal code representing the identified accessories Refer to Chapter 7 OPTION KITS AND ACCESSORIES on page 7-1
P0029	Power Hardware Config.	Hexadecimal code according to the available models and option kits. Refer to the software manual for a complete code list
P0030	IGBTs Temperature U	-20.0 to 150.0 °C
P0031	IGBTs Temperature V	-20.0 to 150.0 °C
P0032	IGBTs Temperature W	-20.0 to 150.0 °C
P0033	Rectifier Temperature	-20.0 to 150.0 °C
P0034	Internal Air Temp.	-20.0 to 150.0 °C
P0036	Fan Heatsink Speed	0 to 15000 rpm
P0037	Motor Overload Status	0 to 100 %
P0038	Encoder Speed	0 to 65535 rpm
P0040	PID Process Variable	0.0 to 100.0 %
P0041	PID Setpoint Value	0.0 to 100.0 %
P0042	Time Powered	0 to 65535 h
P0043	Time Enabled	0.0 to 6553.5 h
P0044	kWh Output Energy	0 to 65535 kWh
P0045	Fan Enabled Time	0 to 65535 h
P0048	Present Alarm	0 to 999
P0049	Present Fault	0 to 999

Parameter	Description	Adjustable Range
P0050	Last Fault	0 to 999
P0051	Last Fault Day/Month	00/00 to 31/12
P0052	Last Fault Year	00 to 99
P0053	Last Fault Time	00:00 to 23:59
P0054	Second Fault	0 to 999
P0055	Second Flt. Day/Month	00/00 to 31/12
P0056	Second Fault Year	00 to 99
P0057	Second Fault Time	00:00 to 23:59
P0058	Third Fault	0 to 999
P0059	Third Fault Day/Month	00/00 to 31/12
P0060	Third Fault Year	00 to 99
P0061	Third Fault Time	00:00 to 23:59
P0062	Fourth Fault	0 to 999
P0063	Fourth Flt. Day/Month	00/00 to 31/12
P0064	Fourth Fault Year	00 to 99
P0065	Fourth Fault Time	00:00 to 23:59
P0066	Fifth Fault	0 to 999
P0067	Fifth Fault Day/Month	00/00 to 31/12
P0068	Fifth Fault Year	00 to 99
P0069	Fifth Fault Time	00:00 to 23:59
P0070	Sixth Fault	0 to 999
P0071	Sixth Fault Day/Month	00/00 to 31/12
P0072	Sixth Fault Year	00 to 99
P0073	Sixth Fault Time	00:00 to 23:59
P0074	Seventh Fault	0 to 999
P0075	Seventh Flt. Day/Month	00/00 to 31/12
P0076	Seventh Fault Year	00 to 99
P0077	Seventh Fault Time	00:00 to 23:59
P0078	Eighth Fault	0 to 999
P0079	Eighth Flt. Day/Month	00/00 to 31/12
P0080	Eighth Fault Year	00 to 99
P0081	Eighth Fault Time	00:00 to 23:59
P0082	Ninth Fault	0 to 999
P0083	Ninth Fault Day/Month	00/00 to 31/12
P0084	Ninth Fault Year	00 to 99
P0085	Ninth Fault Time	00:00 to 23:59
P0086	Tenth Fault	0 to 999
P0087	Tenth Fault Day/Month	00/00 to 31/12
P0088	Tenth Fault Year	00 to 99
P0089	Tenth Fault Time	00:00 to 23:59
P0090	Current At Last Fault	0.0 to 4000.0 A
P0091	DC Link At Last Fault	0 to 2000 V
P0092	Speed At Last Fault	0 to 18000 rpm
P0093	Reference Last Fault	0 to 18000 rpm
P0094	Frequency Last Fault	0.0 to 300.0 Hz
P0095	Motor Volt. Last Fault	0 to 2000 V
P0096	Dlx Status Last Fault	0000h to 00FFh
P0097	DOx Status Last Fault	0000h to 001Fh

5.3 DATE AND TIME SETTING

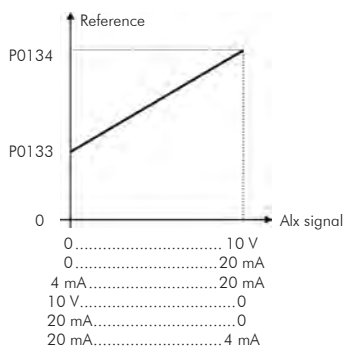
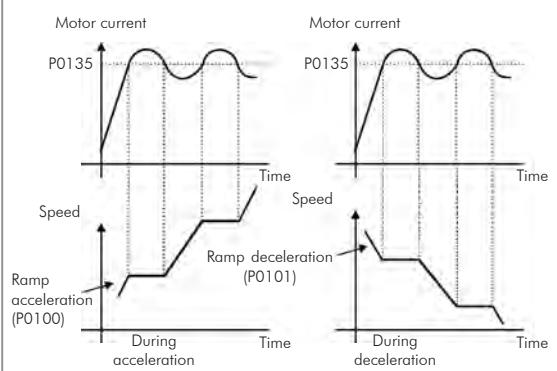
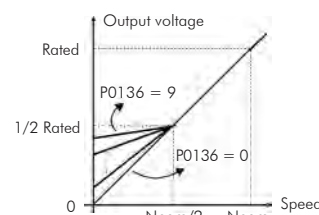



Step	Action/Result	Display Indication
1	- Monitoring mode - Press "Menu" (right soft key)	Ready C LOC 0rpm 0 rpm 0.0 A 0.0 Hz 16:10 Menu
2	- Group "00 ALL PARAMETERS" is already selected 	Ready C LOC 0rpm 00 ALL PARAMETERS 01 PARAMETER GROUPS 02 ORIENTED START-UP 03 CHANGED PARAMETERS Return 16:10 Select
3	- Group "01 PARAMETER GROUPS" is selected - Press "Select"	Ready C LOC 0rpm 00 ALL PARAMETERS 01 PARAMETER GROUPS 02 ORIENTED START-UP 03 CHANGED PARAMETERS Return 16:10 Select
4	- A new list of groups is displayed and group "20 Ramps" is selected - Press  until you reach group "30 HMI"	Ready C LOC 0rpm 20 Ramps 21 Speed References 22 Speed Limits 23 V/F Control Return 16:10 Select
5	- Group "30 HMI" is selected - Press "Select"	Ready C LOC 0rpm 27 V/F DC Volt. Limit. 28 Dynamic Braking 29 Vector Control 30 HMI Return 16:10 Select
6	- Parameter "Day P0194" is already selected - If needed, set P0194 according to the actual day. To do so, press "Select" and then, and  or  to change P0194 value - Follow the same steps to set parameters "Month P0195" to "Seconds P0199"	Ready C LOC 0rpm Day P0194: 06 Month P0195: 10 Return 16:10 Select
7	- Once the setting of P0199 is over, the Real Time Clock is now updated - Press "Return" (left soft key)	Ready C LOC 0rpm Minutes P0198: 11 Seconds P0199: 34 Return 18:11 Select
8	- Press "Return"	Ready C LOC 0rpm 27 V/F DC Volt. Limit. 28 Dynamic Braking 29 Vector Control 30 HMI Return 18:11 Select
9	- Press "Return"	Ready C LOC 0rpm 00 ALL PARAMETERS 01 PARAMETER GROUPS 02 ORIENTED START-UP 03 CHANGED PARAMETERS Return 18:11 Select
10	- The display is back to the monitoring mode	Ready C LOC 0rpm 0 rpm 0.0 A 0.0 Hz 18:11 Menu

Figure 5.4 - Date and time setting

5.4 BLOCKING PARAMETERS MODIFICATION

To prevent unauthorized or unintended parameters modification, parameter P0000 should be set to a value different from 5. Follow the same procedures described in [Item 5.2.1 P0000 Password Setting on page 5-3](#).

5.5 HOW TO CONNECT A PC



NOTES!

- Always use a standard host/device shielded USB cable. Unshielded cables may lead to communication errors.
- Recommended cables: Samtec:
 - USBC-AM-MB-B-B-S-1 (1 meter).
 - USBC-AM-MB-B-B-S-2 (2 meters).
 - USBC-AM-MB-B-B-S-3 (3 meters).
- The USB connection is galvanically isolated from the mains power supply and from other internal inverter high voltages. However, the USB connection is not isolated from the protective ground (PE). Use an isolated notebook for the USB connection or a desktop connected to the same protective ground (PE) of the inverter.

Install the SuperDrive G2 software in order to control the motor speed, and view or edit the inverter parameters through a personal computer (PC).

Basic procedures for transferring data from the PC to the inverter:

1. Install the SuperDrive G2 software in the PC.
2. Connect the PC to the inverter through an USB cable.
3. Start SuperDrive G2.
4. Choose "Open" and the files stored in the PC will be displayed.
5. Select the file.
6. Use the command "Write Parameters to the Drive".
 - All parameters are now transferred to the inverter.

For further information on the SuperDrive G2 software, refer to the SuperDrive manual.

5.6 FLASH MEMORY MODULE

Location as presented in [Figure 2.4 on page 2-10](#).

Functions:

- Store a copy of the inverter parameters.
- Transfer parameters stored in the FLASH memory to the inverter.
- Transfer firmware stored in the FLASH memory to the inverter.
- Store the program created with SoftPLC.

Whenever the inverter is powered up, this program is transferred to the RAM memory located in the inverter control board and executed.

Refer to the CFW-11 programming manual and to SoftPLC manual for further details.



ATTENTION!

Before installing or removing the FLASH memory module, disconnect the inverter power supply and wait for the complete discharge of the capacitors.

6 TROUBLESHOOTING AND MAINTENANCE

This chapter presents:

- A lists of all the faults and alarms that may occur.
- The possible causes of each fault and alarm.
- A lists of the most frequent problems and corrective actions.
- Instructions for periodic inspections and preventive maintenance on the equipment.

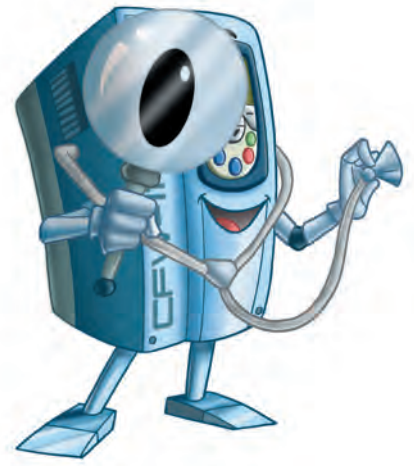

6.1 OPERATION OF FAULTS AND ALARMS

When a fault is detected (FXXX) is detected:

- ☑ The PWM pulses are blocked.
- ☑ The keypad displays the fault code and description.
- ☑ The "STATUS" LED starts flashing red.
- ☑ The output relay set to "NO FAULT" opens.
- ☑ Some data is saved in the control circuit EEPROM memory:
 - Keypad and EP (Electronic Pot) speed references, in case the function "Reference backup" is enabled in P0120.
 - The "FAULT" or alarm potentiometer code that occurred (shifts the last nine previous faults and alarms).
 - The state of the motor overload function integrator.
 - The state of the operating hours counter (P0043) and the powered-up hours counter (P0042).

For the inverter to return to normal operation right after the occurrence of a fault, it is necessary to reset it, which can be done as follows:

- ☑ Removing the power supply and reapplying it (power-on reset).
- ☑ Pressing the HMI  key (manual reset).
- ☑ Through the "Reset" soft key.
- ☑ Automatically by setting P0340 (auto-reset).
- ☑ Through a digital input: DIx = 20 (P0263 to P0270).

When an alarm situation (AXXX) is detected:

- ☑ The keypad displays the alarm code and description.
- ☑ The "STATUS" LED changes to yellow.
- ☑ The PWM pulses are not blocked (the inverter remains operating).

6.2 FAULTS, ALARMS, AND POSSIBLE CAUSES

Table 6.1 - Faults, alarms and possible causes

Fault/Alarm	Description	Possible Causes
F006 Imbalance or Input Phase Loss	Mains voltage imbalance too high or phase missing at the input power supply. Note: - If the motor is unloaded or operating with reduced load, this fault may not occur. - Fault delay is set at parameter P0357. P0357 = 0 disables the fault.	<ul style="list-style-type: none"> ☑ Phase missing at the inverter input power supply. ☑ Input voltage imbalance > 5 %. ☑ Pre-charge circuit fault.
F021 DC Bus Undervoltage	DC bus undervoltage condition occurred.	<ul style="list-style-type: none"> ☑ The input voltage is too low and the DC bus voltage dropped below the minimum permitted value (monitor the value at Parameter P0004): Ud < 385 V - for supply voltage 380 V (P0296 = 1). Ud < 405 V - for supply voltage 400-415 V (P0296 = 2). Ud < 446 V - for supply voltage 440-460 V (P0296 = 3). Ud < 487 V - for supply voltage 480 V (P0296 = 4). ☑ Phase loss at the input power supply. ☑ Pre-charge circuit failure. ☑ Parameter P0296 was set to a value above the power supply rated voltage.
F022 DC Bus Overvoltage	DC bus overvoltage condition occurred.	<ul style="list-style-type: none"> ☑ The input voltage is too high and the DC bus voltage surpassed the maximum permitted value: Ud > 800 V - for 380-480 V models (P0296 = 1, 2, 3 or 4). ☑ Inertia of the driven-load is too high or deceleration time is too short. ☑ Parameters P0151 or P0153 or P0185 set to high.
F030 Power Module U Fault	Power Module U IGBTs desaturation.	☑ Short-circuit between motor phases U and V or U and W.
F034 Power Module V Fault	Power Module V IGBTs desaturation.	☑ Short-circuit between motor phases V and U or V and W.
F038 Power Module W Fault	Power Module W IGBT desaturation.	☑ Short-circuit between motor phases W and U or W and V.
F042 DB IGBT Fault	Desaturation of Dynamic Braking IGBT occurred.	☑ Short-circuit between the connection cables of the dynamic braking resistor.
A046 High Load on Motor	Load is too high for the used motor. Note: It may be disabled by setting P0348 = 0 or 2.	<ul style="list-style-type: none"> ☑ Settings of P0156, P0157, and P0158 are too low for the used motor. ☑ Motor shaft load is excessive.
A047 IGBT Overload Alarm	An IGBT overload alarm occurred. Note: It may be disabled by setting P0350 = 0 or 2.	☑ Inverter output current is too high.
F048 IGBT Overload Fault	An IGBT overload fault occurred.	☑ Inverter output current is too high.

Fault/Alarm	Description	Possible Causes
A050 U Phase IGBT High Temperature	The IGBT NTC temperature sensors detected a high temperature alarm. Note: It may be disabled by setting P0353 = 2 or 3.	<input checked="" type="checkbox"/> High inverter surrounding air temperature (> 50 °C (122 °F)). and high output current. <input checked="" type="checkbox"/> Blocked or defective fan. <input checked="" type="checkbox"/> Very dirty heatsink.
F051 U Phase IGBT Overtemperature	The IGBT NTC temperature sensors detected an overtemperature fault.	
A053 V Phase IGBT High Temperature	The IGBT NTC temperature sensors detected a high temperature alarm. Note: It may be disabled by setting P0353 = 2 or 3.	
F054 V Phase IGBT Overtemperature	The IGBT NTC temperature sensors detected an overtemperature fault.	
A056 W Phase IGBT High Temperature	The IGBT NTC temperature sensors detected a high temperature alarm. Note: It may be disabled by setting P0353 = 2 or 3.	
F057 W Phase IGBT Overtemperature	The IGBT NTC temperature sensors detected an overtemperature fault.	
F062 ⁽⁷⁾ Thermal Imbalance	Fault of power module temperature imbalance.	<input checked="" type="checkbox"/> The temperature difference between IGBTs modules of the same phase (U, V, W) was above 15 °C (59 °F). <input checked="" type="checkbox"/> The temperature difference between IGBTs modules of the same phase (U, V, W) was above 20 °C (68 °F). <input checked="" type="checkbox"/> The temperature difference between rectifier modules of different phases (R and S, R and T, S and T) was above 15 °C (59 °F).
F067 Encoder / Motor Wiring is Inverted	Fault related to the phase relation of the encoder signals if P0202 = 4 and P0408 = 2, 3 or 4. Note: - It is not possible to reset this fault during the selftuning. - It is not possible to reset this fault. - In this case, turn off the power supply, solve the problem, and then turn it on again.	<input checked="" type="checkbox"/> Output motor cables U, V, W are inverted. <input checked="" type="checkbox"/> Encoder channels A and B are inverted. <input checked="" type="checkbox"/> Encoder was not properly mounted.
F071 Output Overcurrent	Output overcurrent fault.	<input checked="" type="checkbox"/> Excessive load inertia or acceleration time too short. <input checked="" type="checkbox"/> Settings of P0135 or P0169, P0170, P0171, and P0172 are too high.
F072 Motor Overload	Fault of motor current imbalance. Note: It may be disabled by setting P0348 = 0 or 3.	<input checked="" type="checkbox"/> Settings of P0156, P0157, and P0158 are too low for the used motor. <input checked="" type="checkbox"/> Excessive load at the motor shaft.
F074 Ground Fault	Ground overcurrent fault. Note: It may be disabled by setting P0343 = 0.	<input checked="" type="checkbox"/> Short-circuit to the ground at one or more of the output phases. <input checked="" type="checkbox"/> Motor cable capacitance is too large, resulting in current peaks at the output. ⁽⁵⁾
F076 Motor Current Imbalance	Fault of motor current imbalance. Note: It may be disabled by setting P0342 = 0.	<input checked="" type="checkbox"/> Loose connection or interrupted wiring between motor and inverter. <input checked="" type="checkbox"/> Vector control lost orientation. <input checked="" type="checkbox"/> Vector control with inverted encoder wiring or inverted motor connection.
F077 DB Resistor Overload	The dynamic braking resistor overload protection tripped.	<input checked="" type="checkbox"/> Excessive load inertia or deceleration time too short. <input checked="" type="checkbox"/> Excessive load at the motor shaft. <input checked="" type="checkbox"/> Parameter P0154 and P0155 incorrect setting.
F078 Motor Overtemperature	Fault related to the PTC temperature sensor installed in the motor. Note: - It may be disabled by setting P0351 = 0 or 3. - It is necessary to set an analog input / output to the PTC function.	<input checked="" type="checkbox"/> Excessive load at the motor shaft. <input checked="" type="checkbox"/> Too heavy duty cycle (too many starts/stops per minute). <input checked="" type="checkbox"/> Too high motor surrounding air temperature. <input checked="" type="checkbox"/> Loose connection or short-circuit (resistance < 60 Ω) in the wiring connected to the motor thermistor. <input checked="" type="checkbox"/> Motor thermistor is not installed. <input checked="" type="checkbox"/> Blocked motor shaft.
F079 Encoder Signal Fault	Lack of encoder signals.	<input checked="" type="checkbox"/> Broken wires between the motor encoder and the option and the encoder interface board. <input checked="" type="checkbox"/> Defective encoder.
F080 CPU Watchdog	Microcontroller watchdog fault.	<input checked="" type="checkbox"/> Electrical noise.
F082 Copy Function Fault	Fault while copying parameters.	<input checked="" type="checkbox"/> Communication problem with the HMI.

Fault/Alarm	Description	Possible Causes
F084 Auto-diagnosis Fault	Auto-diagnosis fault.	<ul style="list-style-type: none"> <input checked="" type="checkbox"/> Internal inverter circuitry defect.
A088 Communication Lost	A failure in the communication between the HMI and the control board.	<ul style="list-style-type: none"> <input checked="" type="checkbox"/> Loose keypad cable connection. <input checked="" type="checkbox"/> Electrical noise in the installation.
A090 External Alarm	External alarm via digital input. Note: It is necessary to set a digital input for "no external alarm".	<ul style="list-style-type: none"> <input checked="" type="checkbox"/> Open wiring at digital inputs (DI1 to DI8) programmed for "no external alarm".
F091 External Fault	External fault via digital input. Note: It is necessary to set a digital input to "no external fault".	<ul style="list-style-type: none"> <input checked="" type="checkbox"/> Open wiring at digital inputs (DI1 to DI8) programmed for "no external fault".
F099 Invalid Current Offset	Current measurement circuit is measuring a wrong value for null current.	<ul style="list-style-type: none"> <input checked="" type="checkbox"/> Defect in the inverter internal circuitry.
A110 High Motor Temperature	Alarm related to the PTC temperature sensor installed in the motor. Note: - It may be disabled by setting P0351 = 0 or 2. - It is necessary to set an analog input/output to the PTC function.	<ul style="list-style-type: none"> <input checked="" type="checkbox"/> Excessive load at the motor shaft. <input checked="" type="checkbox"/> Too heavy duty cycle (too many starts / stops per minute). <input checked="" type="checkbox"/> Too high motor surrounding air temperature. <input checked="" type="checkbox"/> Motor thermistor is not installed. <input checked="" type="checkbox"/> Blocked motor shaft.
A128 Timeout for Serial Communication	Indicates that the inverter stopped receiving valid telegrams within a certain time interval. Note: It may be disabled by setting P0314 = 0.0 s.	<ul style="list-style-type: none"> <input checked="" type="checkbox"/> Check the wiring and grounding installation. <input checked="" type="checkbox"/> Make sure the inverter has sent a new telegram within the time interval set at P0314.
A129 Anybus is Offline	Alarm that indicates interruption of the Anybus-CC communication.	<ul style="list-style-type: none"> <input checked="" type="checkbox"/> The PLC has entered the idle state. <input checked="" type="checkbox"/> Programming error. Master and slave set with a different number of I/O words. <input checked="" type="checkbox"/> Communication with master has been lost (broken cable, unplugged connector, etc.).
A130 Anybus Access Error	Alarm that indicates an access error to the Anybus-CC communication module.	<ul style="list-style-type: none"> <input checked="" type="checkbox"/> Defective, unrecognized, or incorrectly installed Anybus-CC module. <input checked="" type="checkbox"/> Conflict with a WEG option board.
A133 CAN Not Powered	Alarm indicating that the power supply was not connected to the CAN controller.	<ul style="list-style-type: none"> <input checked="" type="checkbox"/> Broken or loose cable. <input checked="" type="checkbox"/> Power supply is off.
A134 Bus Off	Inverter CAN interface has entered the bus-off state.	<ul style="list-style-type: none"> <input checked="" type="checkbox"/> Incorrect baud-rate. <input checked="" type="checkbox"/> Two nodes configured with the same address in the network. <input checked="" type="checkbox"/> Wrong cable connection (inverted signals).
A135 CANopen Communication Error	Alarm that indicates a communication error.	<ul style="list-style-type: none"> <input checked="" type="checkbox"/> Communication problems. <input checked="" type="checkbox"/> Wrong master configuration/settings. <input checked="" type="checkbox"/> Incorrect configuration of the communication objects.
A136 Idle Master	Network master has entered the idle state.	<ul style="list-style-type: none"> <input checked="" type="checkbox"/> PLC in IDLE mode. <input checked="" type="checkbox"/> Bit of the PLC command register set to zero (0).
A137 DNet Connection Timeout	DeviceNet I/O connection timeout alarm.	<ul style="list-style-type: none"> <input checked="" type="checkbox"/> One or more allocated I/O connections have entered the timeout state.
A138 ⁽¹⁾ Profibus DP Interface in Clear Mode	It indicates that the inverter received a command from the Profibus DP network master to enter the clear mode.	<ul style="list-style-type: none"> <input checked="" type="checkbox"/> Verify the network master status, making sure it is in execution mode (Run). <input checked="" type="checkbox"/> Refer to the Profibus DP communication manual for more information.
A139 ⁽¹⁾ Offline Profibus DP Interface	It indicates an interruption in the communication between the Profibus DP network master and the inverter.	<ul style="list-style-type: none"> <input checked="" type="checkbox"/> Verify whether the network master is correctly configured and operating normally. <input checked="" type="checkbox"/> Verify the network installation in a general manner - cable routing, grounding. <input checked="" type="checkbox"/> Refer to the Profibus DP communication manual for more information.
A140 ⁽¹⁾ Profibus DP Module Access Error	It indicates an error in the access to the Profibus DP communication module data.	<ul style="list-style-type: none"> <input checked="" type="checkbox"/> Verify whether the Profibus DP module is correctly fit into the slot 3. <input checked="" type="checkbox"/> Refer to the Profibus DP communication manual for more information.
F150 Motor Overspeed	Overspeed fault. It is activated when the real speed exceeds the value of P0134 x (100 % + P0132) for more than 20 ms.	<ul style="list-style-type: none"> <input checked="" type="checkbox"/> Wrong settings of P0161 and/or P0162. <input checked="" type="checkbox"/> Problem with the hoist-type load.
F151 FLASH Memory Module Fault	FLASH memory module (MMF-03) fault.	<ul style="list-style-type: none"> <input checked="" type="checkbox"/> Defective FLASH memory module. <input checked="" type="checkbox"/> FLASH memory module is not connected properly.

Fault/Alarm	Description	Possible Causes
A152 Internal Air High Temperature	Alarm indicating that the internal air temperature is too high. Note: It may be disabled by setting P0353 = 1 or 3.	<input checked="" type="checkbox"/> Defective internal fan (if existent) and high output current. <input checked="" type="checkbox"/> High temperature inside the cabinet (>45 °C (113 °F)).
F153 Internal Air Overtemperature	Internal air overtemperature fault.	
A156 ⁽⁹⁾ Undertemperature	Only 1 sensor indicates temperature below -30 °C (-22 °F).	<input checked="" type="checkbox"/> Surrounding air temperature ≤ -30 °C (-22 °F).
F156 Undertemperature	Undertemperature fault (below -30 °C (-22 °F) ⁽⁹⁾) in the IGBTs or rectifier measured by the temperature sensors.	<input checked="" type="checkbox"/> Surrounding air temperature ≤ -30 °C (-22 °F) ⁽⁹⁾ .
F160 Safety Stop Relays	Safety Stop relay fault.	<input checked="" type="checkbox"/> One of the relays is defective or it does not have +24 Vdc applied to its coil.
F161 Timeout PLC11 CFW-11	<input checked="" type="checkbox"/> Refer to the PLC11-01 module programming manual.	
A162 Incompatible PLC Firmware		
A163 AI1 Broken Wire	It indicates that the AI1 current signal (4-20 mA or 20-4 mA) is out of the 4 to 20 mA range.	<input checked="" type="checkbox"/> Broken AI1 cable. <input checked="" type="checkbox"/> Bad contact at the signal connection to the terminal strip.
A164 AI2 Broken Wire	It indicates that the AI2 current signal (4-20 mA or 20-4 mA) is out of the 4 to 20 mA range.	<input checked="" type="checkbox"/> Broken AI2 cable. <input checked="" type="checkbox"/> Bad contact at the signal connection to the terminal strip.
A165 AI3 Broken Wire	It indicates that the AI3 current signal (4-20 mA or 20-4 mA) is out of the 4 to 20 mA range.	<input checked="" type="checkbox"/> Broken AI3 cable. <input checked="" type="checkbox"/> Bad contact at the signal connection to the terminal strip.
A166 AI4 Broken Wire	It indicates that the AI4 current signal (4-20 mA or 20-4 mA) is out of the 4 to 20 mA range.	<input checked="" type="checkbox"/> Broken AI4 cable. <input checked="" type="checkbox"/> Bad contact at the signal connection to the terminal strip.
F174 ⁽⁶⁾ Left Fan Speed Fault	Heatsink left fan speed fault.	<input checked="" type="checkbox"/> Dirt on the blades and in the bearings of the fan. <input checked="" type="checkbox"/> Defective fan. <input checked="" type="checkbox"/> Defective fan power supply connection.
F175 ⁽²⁾ Center Fan Speed Fault	Heatsink center fan speed fault.	<input checked="" type="checkbox"/> Dirt on the blades and in the bearings of the fan. <input checked="" type="checkbox"/> Defective fan. <input checked="" type="checkbox"/> Defective fan power supply connection.
F176 Right Fan Speed Fault	Heatsink right fan speed fault.	<input checked="" type="checkbox"/> Dirt on the blades and in the bearings of the fan. <input checked="" type="checkbox"/> Defective fan. <input checked="" type="checkbox"/> Defective fan power supply connection.
A177 Fan Replacement	Heatsink fan replacement alarm (P0045 > 50000 hours). Note: This function may be disabled by setting P0354 = 0.	<input checked="" type="checkbox"/> The maximum number of operating hours for the heatsink fan has been reached.
F179 Heatsink Fan Speed Fault	Heatsink fan speed feedback fault. Note: This function may be disabled by setting P0354 = 0.	<input checked="" type="checkbox"/> Dirt on the blades and in the bearings of the fan. <input checked="" type="checkbox"/> Defective fan. <input checked="" type="checkbox"/> Defective fan power supply connection.
A181 Invalid Clock Value	Invalid clock value alarm.	<input checked="" type="checkbox"/> It is necessary to set date and time at parameters from P0194 to P0199. <input checked="" type="checkbox"/> Keypad battery is discharged, defective, or not installed.
F182 Pulse Feedback Fault	Indicates a fault at the feedback from the output pulses.	<input checked="" type="checkbox"/> No motor connected or the motor connected to the inverter output is too small. <input checked="" type="checkbox"/> Possible defect on the internal circuits of the inverter. Possible solutions: <input checked="" type="checkbox"/> Reset inverter and try again. <input checked="" type="checkbox"/> Set P0356 = 0 and try again.
F183 IGBT Overload + Temperature	Overtemperature related to the IGBTs overload protection.	<input checked="" type="checkbox"/> High surrounding air temperature. <input checked="" type="checkbox"/> Operation with overload at frequencies below 10 Hz.
F185 Pre-charge Contactor Fault	It indicates fault at the pre-charge contactor.	<input checked="" type="checkbox"/> Pre-charge circuit defect.
F186 ⁽³⁾ Sensor 1 Temperature Fault	It indicates a temperature fault at the sensor 1.	<input checked="" type="checkbox"/> Motor high temperature.
F187 ⁽³⁾ Sensor 2 Temperature Fault	It indicates a temperature fault at the sensor 2.	<input checked="" type="checkbox"/> Motor high temperature.
F188 ⁽³⁾ Sensor 3 Temperature Fault	It indicates a temperature fault at the sensor 3.	<input checked="" type="checkbox"/> Motor high temperature.

Fault/Alarm	Description	Possible Causes
F189 ⁽³⁾ Sensor 4 Temperature Fault	It indicates a temperature fault at the sensor 4.	<ul style="list-style-type: none"> <input checked="" type="checkbox"/> Motor high temperature.
F190 ⁽³⁾ Sensor 5 Temperature Fault	It indicates a temperature fault at the sensor 5.	<ul style="list-style-type: none"> <input checked="" type="checkbox"/> Motor high temperature.
A191 ⁽³⁾ Sensor 1 Temperature Alarm	It indicates a temperature alarm at the sensor 1.	<ul style="list-style-type: none"> <input checked="" type="checkbox"/> Motor high temperature. <input checked="" type="checkbox"/> A problem in the wiring connecting the sensor to the IOE-01 (02 or 03).
A192 ⁽³⁾ Sensor 2 Temperature Alarm	It indicates a temperature alarm at the sensor 2.	<ul style="list-style-type: none"> <input checked="" type="checkbox"/> Motor high temperature. <input checked="" type="checkbox"/> A problem in the wiring connecting the sensor to the IOE-01 (02 or 03).
A193 ⁽³⁾ Sensor 3 Temperature Alarm	It indicates a temperature alarm at the sensor 3.	<ul style="list-style-type: none"> <input checked="" type="checkbox"/> Motor high temperature. <input checked="" type="checkbox"/> A problem in the wiring connecting the sensor to the IOE-01 (02 or 03).
A194 ⁽³⁾ Sensor 4 Temperature Alarm	It indicates a temperature alarm at the sensor 4.	<ul style="list-style-type: none"> <input checked="" type="checkbox"/> Motor high temperature. <input checked="" type="checkbox"/> A problem in the wiring connecting the sensor to the IOE-01 (02 or 03).
A195 ⁽³⁾ Sensor 5 Temperature Alarm	It indicates a temperature alarm at the sensor 5.	<ul style="list-style-type: none"> <input checked="" type="checkbox"/> Motor high temperature. <input checked="" type="checkbox"/> A problem in the wiring connecting the sensor to the IOE-01 (02 or 03).
A196 ⁽³⁾ Sensor 1 Cable Alarm	Temperature sensor 1 cable alarm.	<ul style="list-style-type: none"> <input checked="" type="checkbox"/> Shorted temperature sensor.
A197 ⁽³⁾ Sensor 2 Cable Alarm	Temperature sensor 2 cable alarm.	<ul style="list-style-type: none"> <input checked="" type="checkbox"/> Shorted temperature sensor.
A198 ⁽³⁾ Sensor 3 Cable Alarm	Temperature sensor 3 cable alarm.	<ul style="list-style-type: none"> <input checked="" type="checkbox"/> Shorted temperature sensor.
A199 ⁽³⁾ Sensor 4 Cable Alarm	Temperature sensor 4 cable alarm.	<ul style="list-style-type: none"> <input checked="" type="checkbox"/> Shorted temperature sensor.
A200 ⁽³⁾ Sensor 5 Cable Alarm	Temperature sensor 5 cable alarm.	<ul style="list-style-type: none"> <input checked="" type="checkbox"/> Shorted temperature sensor.
F228 Serial Communication Timeout	<input checked="" type="checkbox"/> Refer to the RS232/RS485 Serial communication manual.	
F229 Anybus Offline	<input checked="" type="checkbox"/> Refer to the Anybus-CC communication manual.	
F230 Anybus Access Error		
F233 CAN Bus Power Failure	<input checked="" type="checkbox"/> Refer to the CANopen communication manual and/or the DeviceNet communication manual.	
F234 Bus Off		
F235 CANopen Communication Error	<input checked="" type="checkbox"/> Refer to the CANopen communication manual.	
F236 Master Idle	<input checked="" type="checkbox"/> Refer to the DeviceNet communication manual.	
F237 DeviceNet Connection Timeout		
F238 ⁽¹⁾ Profibus DP Interface in Clear Mode	It indicates that the inverter received a command from the Profibus DP network master to enter the clear mode.	<ul style="list-style-type: none"> <input checked="" type="checkbox"/> Verify the network master status, making sure it is in execution mode (Run). <input checked="" type="checkbox"/> The fault indication will occur if P0313 = 5. <input checked="" type="checkbox"/> Refer to the Profibus DP communication manual for more information.
F239 ⁽¹⁾ Offline Profibus DP Interface	It indicates an interruption in the communication between the Profibus DP network master and the inverter.	<ul style="list-style-type: none"> <input checked="" type="checkbox"/> Verify whether the network master is correctly configured and operating normally. <input checked="" type="checkbox"/> Verify the network installation in a general manner - cable routing, grounding. <input checked="" type="checkbox"/> The fault indication will occur if P0313 = 5. <input checked="" type="checkbox"/> Refer to the Profibus DP communication manual for more information.
F240 ⁽¹⁾ Profibus DP Module Access Error	It indicates an error in the access to the Profibus DP communication module data.	<ul style="list-style-type: none"> <input checked="" type="checkbox"/> Verify whether the Profibus DP module is correctly fit into the slot 3. <input checked="" type="checkbox"/> The fault indication will occur if P0313 = 5. <input checked="" type="checkbox"/> Refer to the Profibus DP communication manual for more information.

Fault/Alarm	Description	Possible Causes
F416 ⁽⁷⁾ IGBT Current Imb. Fault	Fault of current imbalance on the IGBTs.	<input checked="" type="checkbox"/> IGBTs of the same phase presented a current imbalance above 15 %.
A417 ⁽⁷⁾ Thermal Imbalance	The temperature difference between IGBT modules of the same phase (U, V, W) was above 10 °C (50 °F).	<input checked="" type="checkbox"/> The temperature difference between IGBT modules of different phases (U and V, U and W, V and W) was above 10 °C (50 °F). The temperature difference between rectifier modules of different phases (R and S, R and T, S and T) was above 10 °C (50 °F).
F418 ⁽⁷⁾ Air Control Overtemperature	Fault of overtemperature of the internal air on the control board.	<input checked="" type="checkbox"/> Temperature of the internal air of the control board is above 85 °C (185 °F).
A419 ⁽⁷⁾ Control Air Temperature High Alarm	Alarm of overtemperature of the internal air on the control board.	<input checked="" type="checkbox"/> When the temperature of the internal air of the control board is above 70 °C (158 °F).
A700 ⁽⁴⁾ Disconnected HMI	Alarm or fault related to the HMI disconnection.	<input checked="" type="checkbox"/> RTC function block has been activated in the SoftPLC applicative and the HMI is disconnected from the inverter.
F701 ⁽⁴⁾ Disconnected HMI		
A702 ⁽⁴⁾ Disabled Inverter	Alarm indicating that the General Enable command is not active.	<input checked="" type="checkbox"/> The SoftPLC Run/Stop command is equal to Run or a movement block has been enable while the inverter is general disabled.
A704 ⁽⁴⁾ Two Enabled Movements	Two movements have been enabled.	<input checked="" type="checkbox"/> It occurs when two or more movement blocks are enabled simultaneously.
A706 ⁽⁴⁾ Speed Reference not Programmed for SoftPLC	Speed reference not programmed for SoftPLC.	<input checked="" type="checkbox"/> It occurs when a movement block has been enabled and the speed reference has not been configured for SoftPLC (check P0221 and P0222).

Models where they can occur and additional notes:

(1) With a Profibus DP module connected into the slot 3 (XC43).

(2) All the frame sizes G and H models.

(3) With an IOE-01 (02 or 03) module connected into the slot 1 (XC41).

(4) All the models with a SoftPLC applicative.

(5) Very long motor cables (longer than 100 meters) present a high parasite capacitance against the ground. The circulation of parasite currents through those capacitances may cause the ground fault circuit activation and thus disabling the inverter with F074, immediately after the inverter enabling.

(6) CFW110370T4, CFW110477T4, and all the frame sizes G and H models.

(7) Only frame size H.

(8) Below -20 °C (-4 °F) for frame size H.

(9) Only for models of frame sizes F and G.



NOTE!

The range from P0750 to P0799 is destined to the SoftPLC applicative user faults and alarms.

6.3 SOLUTIONS FOR THE MOST FREQUENT PROBLEMS

Table 6.2 - Solutions for the most frequent problems

Problem	Point to be Verified	Corrective Action
Motor does not start	Incorrect wiring	1. Check all power and control connections. For instance, the digital inputs set to start/stop, general enable, or no external error must be connected to the 24 Vdc or to DGND* terminals (refer to Figure 3.16 on page 3-31)
	Analog reference (if used)	1. Check if the external signal is properly connected 2. Check the status of the control potentiometer (if used)
	Incorrect settings	1. Check if the parameter values are correct for the application
	Fault	1. Check whether the inverter is disabled due to a fault condition 2. Make sure that the terminals XC1:13 and XC1:11 are not shorted (short-circuit at the 24 Vdc power supply)
	Stalled motor	1. Decrease the motor overload 2. Increase P0136, P0137 (V/f), or P0169/P0170 (vector control)
Motor speed oscillates	Loose connections	1. Stop the inverter, turn off the power supply, check and tighten all the power connections 2. Check all the internal connections of the inverter
	Defective speed reference potentiometer	1. Replace the potentiometer
	Oscillation of the external analog reference	1. Identify the cause of the oscillation. If it is caused by electrical noise, use shielded cables or separate them from the power and control wiring
	Incorrect settings (vector control)	1. Check parameters P0410, P0412, P0161, P0162, P0175, and P0176 2. Refer to the programming manual
Too high or too low motor speed	Incorrect settings (reference limits)	1. Check whether the values of P0133 (minimum speed) and P0134 (maximum speed) are properly set for the used motor and application
	Control signal from the analog reference (if used)	1. Check the level of the reference control signal 2. Check the settings (gain and offset) of parameters P0232 to P0249
	Motor nameplate	1. Check whether the used motor matches the application
Motor does not reach the rated speed, or motor speed starts oscillating around the rated speed (Vector Control)	Settings	1. Decrease P0180 2. Check P0410
Display is off	Keypad connections	1. Check the inverter keypad connection
	Power supply voltage	1. Rated values must be within the limits specified below: 380-480 V power supply: - Minimum: 323 V - Maximum: 528 V
	Mains supply fuses open	1. Replace the fuses
Motor does not operate in the field weakening region (Vector Control)	Settings	1. Decrease P0180
Low motor speed and P0009 = P0169 or P0170 (motor operating with torque limitation), for P0202 = 4 - vector with encoder	Encoder signals are inverted or power connections are inverted	1. Check signals A - \bar{A} , B - \bar{B} , refer to the incremental encoder interface manual. If signals are properly wired, invert two of the output phases. For instance U and V

6.4 INFORMATION NECESSARY FOR CONTACTING TECHNICAL SUPPORT



NOTE!

For technical support and servicing, it is important to have the following information in hand:

- ☑ Inverter model.
- ☑ Serial number, manufacturing date, and hardware revision that are listed in the product nameplate (refer to the [Section 2.4 CFW-11 IDENTIFICATION LABELS on page 2-12](#)).
- ☑ Installed software version (check parameter P0023).
- ☑ Application data and inverter settings.

6.5 PREVENTIVE MAINTENANCE



DANGER!

- ☑ Always turn off the mains power supply before touching any electrical component associated to the inverter.
- ☑ High voltage may still be present even after disconnecting the power supply.
- ☑ To prevent electric shock, wait at least 10 minutes after turning off the input power for the complete discharge of the power capacitors.
- ☑ Always connect the equipment frame to the protective ground (PE). Use the adequate connection terminal at the inverter.



DANGER!

- ☑ Débranchez toujours l'alimentation principale avant d'entrer en contact avec un appareil électrique associé au variateur.
- ☑ Des tensions élevées peuvent encore être présentes, même après déconnexion de l'alimentation.
- ☑ Pour éviter les risques d'électrocution, attendre au moins 10 minutes après avoir coupé l'alimentation d'entrée pour que les condensateurs de puissance soient totalement déchargés.
- ☑ Raccordez toujours la masse de l'appareil à une terre protectrice (PE). Utiliser la borne de connexion adéquate du variateur.



ATTENTION!

The electronic boards have electrostatic discharge sensitive components. Do not touch the components or connectors directly. If necessary, first touch the grounded metallic frame or wear a ground strap.

**Do not perform any withstand voltage test!
If necessary, consult WEG.**

The inverters require low maintenance when properly installed and operated. The [Table 6.3 on page 6-9](#) presents the main procedures and time intervals for preventive maintenance. The [Table 6.4 on page 6-10](#) provides recommended periodic inspections to be performed every 6 months after the inverter start-up.

Table 6.3 - Preventive maintenance

Maintenance		Interval	Instructions
Fan replacement		After 50000 operating hours ⁽¹⁾	Replacement procedure showed in Figure 6.1 on page 6-11
Keypad battery replacement		Every 10 years	Refer to the Chapter 4 HMI on page 4-1 .
Electrolytic capacitors ⁽²⁾	If the inverter is stocked (not being used): "Reforming"	Every year from the manufacturing date printed on the inverter identification label (refer to the Section 2.4 CFW-11 IDENTIFICATION LABELS on page 2-12)	Apply power to the inverter rated voltage and frequency for at least one hour. Then, disconnect the power supply and wait at least 24 hours before using the inverter (reapply power)
	Inverter is being used: replace	Every 10 years	Contact WEG technical support to obtain replacement procedures

(1) The inverters are set at the factory for automatic fan control (P0352 = 2), which means that they will be turned on only when the heatsink temperature exceeds a reference value. Therefore, the operating hours of the fan will depend on the inverter usage conditions (motor current, output frequency, cooling air temperature, etc.). The inverter stores the number of fan operating hours in the parameter P0045. When this parameter reaches 50000 operating hours, the keypad display shows the alarm A177.

(2) Valid for frame sizes F and G only.

Table 6.4 - Recommended periodic inspections - Every 6 months

Component	Abnormality	Corrective Action
Terminals, connectors	Loose screws	Tighten
	Loose connectors	
Fans/cooling system	Dirty fans	Cleaning
	Abnormal acoustic noise	Replace the fan. Refer to the Figure 6.1 on page 6-11 for the removal of the fan. Install the new fan in the reverse sequence of the removal Check the fan connections
	Blocked fan	
	Abnormal vibration	
	Dust in the cabinet air filter	Cleaning or replacement
Printed circuit boards	Accumulation of dust, oil, humidity, etc	Cleaning
	Odor	Replacement
Power module/power connections	Accumulation of dust, oil, humidity, etc	Cleaning
	Loose connection screws	Tighten
DC bus capacitors (DC link)	Discoloration/odor/electrolyte leakage	Replacement
	Expanded or broken safety valve	
	Frame expansion	
Power resistors	Discoloration	Replacement
	Odor	
Heatsink	Dust accumulation	Cleaning
	Dirty	

6.5.1 Cleaning Instructions

When it is necessary to clean the inverter, follow the instructions below:

Ventilation system:

- ☑ Disconnect the inverter power supply and wait at least 10 minutes.
- ☑ Remove the dust from the cooling air inlet by using a soft brush or a flannel.
- ☑ Remove the dust from the heatsink fins and from the fan blades by using compressed air.

Electronic boards:

- ☑ Disconnect the inverter power supply and wait at least 10 minutes.
- ☑ Remove the dust from the electronic board by using an anti-static brush or an ion air gun (Charges Burtes Ion Gun - reference A6030-6DESCO).
- ☑ If necessary, remove the boards from the inverter.
- ☑ Always wear a ground strap.



Figure 6.1 - Removal of the heatsink fans

7 OPTION KITS AND ACCESSORIES

This chapter presents:

- ☑ The option kits that can be integrated to the inverter from the factory:
 - Safety Stop.
 - External 24 Vdc power supply for control and keypad.
- ☑ Instructions for the proper use of the option kits.
- ☑ The accessories that can be integrated to the inverters.



Instructions for the installation, operation, and programming of the accessories are described in their own manuals and are not present in this chapter.

7.1 OPTION KITS

7.1.1 Safety Stop Function

Inverters with the following codification CFW11...O...Y... Refer to [Section 3.3 SAFETY STOP FUNCTION on page 3-38](#).

7.1.2 24 Vdc External Control Power Supply

Inverters with code CFW11XXXXXOW.

The use of this option kit is recommended with communication networks (Profibus, DeviceNet, etc.), since the control circuit and the network communication interface are kept active (with power supply and responding to the network communication commands) even in the event of main power supply interruption.

Inverters with this option have a built-in DC/DC converter with a 24 Vdc input that provides adequate outputs for the control circuit. Therefore, the control circuit power supply will be redundant, i.e., it can be provided either by a 24 Vdc external power supply (connection as shown in [Figure 7.1 on page 7-2](#)) or by the standard internal switched mode power supply of the inverter.

Observe that the inverters with the external 24 Vdc power supply option use terminals XC1:11 and 13 as the input for the external power supply and no longer as the output like in the standard inverter. ([Figure 7.1 on page 7-2](#)).

In case of interruption of the external 24 Vdc power supply, the digital inputs/outputs and analog outputs will no longer be fed, even if the mains power is on. Therefore, it is recommended to keep the 24 Vdc power supply always connected to the terminals XC1:11 and 13.

The keypad displays warnings indicating the inverter status: whether the 24 Vdc power source is connected, whether the mains power source is connected, etc.

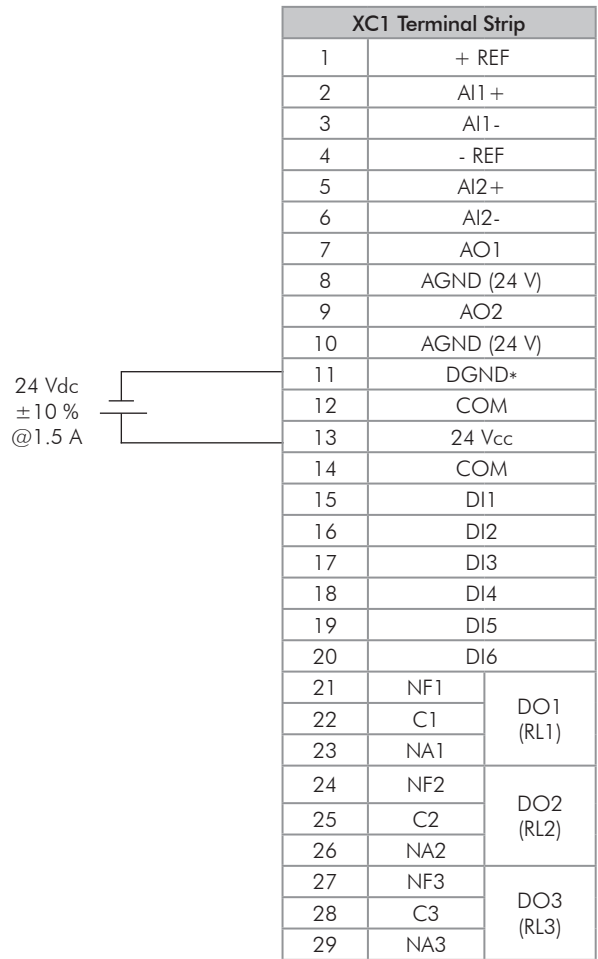

Figure 7.1 - External 24 Vdc power supply capacity and connection terminals



NOTE!

A class 2 power supply must be used in order to comply with the UL508C standard.

7.2 ACCESSORIES

The accessories are installed in the inverter easily and quickly using the "Plug and Play" concept. When the accessory is inserted into the slot, the control circuitry identifies its model and displays the installed accessory code in P0027 or P0028. The accessory must be installed with the inverter power supply off.

Part number and model of each available accessory are presented in [Table 7.1 on page 7-3](#). The accessories can be ordered separately and will be shipped in individual packages containing the components and the manual with detailed instructions for the product installation, operation, and programming.



ATTENTION!

Only one module at a time can be fitted into each slot (1, 2, 3, 4 or 5).

Table 7.1 - Accessory models

WEG Part Number	Name	Description	Slot	Identification Parameters	
				P0027	P0028
Control Accessories for Installation in the Slots 1, 2 and 3					
11008162	IOA-01	IOA module: 1 voltage/current analog input (14 bits); 2 digital inputs; 2 voltage/current analog outputs (14 bits); 2 open-collector digital outputs	1	FD--	----
11008099	IOB-01	IOB module: 2 isolated analog inputs (voltage/current); 2 digital inputs; 2 isolated analog outputs (voltage/current) (the programming of the outputs is identical as in the standard CFW-11); 2 open-collector digital outputs	1	FA--	----
11126674	IOC-01	IOC module with 8 digital inputs and 4 relay outputs (use with SoftPLC)	1	C1	----
11126730	IOC-02	IOC module with 8 digital inputs and 8 NPN open collector digital outputs (use with SoftPLC)	1	C5	----
11820111	IOC-03	IOC module with 8 digital inputs and 7 PNP open collector digital outputs	1	C6	----
11126732	IOE-01	Input module with 5 PTC type sensors	1	25--	----
11126735	IOE-02	Input module with 5 PT100 type sensors	1	23--	----
11126750	IOE-03	Input module with 5 KTY84 type sensors	1	27--	----
11008100	ENC-01	5 to 12 Vdc incremental encoder module, 100 kHz, with an encoder signal repeater	2	--C2	----
11008101	ENC-02	5 to 12 Vdc incremental encoder module, 100 kHz	2	--C2	----
11008102	RS485-01	RS485 serial communication module (Modbus)	3	----	CE--
11008103	RS232-01	RS232C serial communication module (Modbus)	3	----	CC--
11008104	RS232-02	RS232C serial communication module with DIP-switches for programming the microcontroller FLASH memory	3	----	CC--
11008105	CAN/RS485-01	CAN and RS485 interface module (CANopen/DeviceNet/Modbus)	3	----	CA--
11008106	CAN-01	CAN interface module (CANopen/DeviceNet)	3	----	CD--
11045488	PROFIBUS DP-01	Profibus DP communication module	3	----	C9
11008911	PLC11-01	PLC module	1, 2 and 3	----	--xx ^{(1) (3)}
11094251	PLC11-02	PLC module	1, 2 and 3	----	--xx ^{(1) (3)}
Anybus-CC Accessories for Installation in the Slot 4					
11008158	DEVICENET-05	DeviceNet interface module	4	----	--xx ^{(2) (3)}
10933688	ETHERNET/IP-05	Ethernet/IP interface module	4	----	--xx ^{(2) (3)}
11550476	MODBUSTCP-05	Modbus TCP interface module	4	----	--xx ^{(2) (3)}
11550548	PROFINETIP-05	PROFINET IO interface module	4	----	--xx ^{(2) (3)}
11008107	PROFDP-05	Profibus DP interface module	4	----	--xx ^{(2) (3)}
14926615	ETHERCAT-05	EtherCAT communication module	4	----	--xx ^{(2) (3)}
11008161	RS485-05	RS485 (passive) interface module (Modbus)	4	----	--xx ^{(2) (3)}
11008160	RS232-05	RS232 (passive) interface module (Modbus)	4	----	--xx ^{(2) (3)}
Flash Memory Module for Installation in the Slot 5 - Factory Settings Included ⁽⁵⁾					
11719952	MMF-03	FLASH memory module	5	----	--xx ⁽⁶⁾
Stand-alone HMI, Blank Cover, and Frame for Remote Mounted HMI					
11008913	HMI-01	Stand-alone HMI ⁽⁴⁾	HMI	-	-
11010521	RHMIF-01	Remote HMI frame kit IP65	-	-	-
11010298	HMID-01	Blank cover for the HMI slot	HMI	-	-
10950192	HMI CAB-RS-1M	1 m serial remote keypad cable set	-	-	-
10951226	HMI CAB-RS-2M	2 m serial remote keypad cable set	-	-	-
10951223	HMI CAB-RS-3M	3 m serial remote keypad cable set	-	-	-
10951227	HMI CAB-RS-5M	5 m serial remote keypad cable set	-	-	-
10951240	HMI CAB-RS-7.5M	7.5 m serial remote keypad cable set	-	-	-
10951239	HMI CAB-RS-10M	10 m serial remote keypad cable set	-	-	-
Miscellaneous					
10960846	CONRA-01	Control rack (containing the CC11 control board)	-	-	-
10960847	CCS-01	Control cable shielding kit (supplied with the product)	-	-	-
11417558	KN1F-01	Nema1 kit for the frame size F	-	-	-
11417559	KN1G-01	Nema1 kit for the frame size G	-	-	-
11337634	KMF-01	Frame size F movement kit	-	-	-
11337714	KMG-01	Frame size G movement kit	-	-	-
10794631	DBW030380 D3848SZ	Dynamic braking module DBW03	-	-	-
13166838	DBW040380 D3848SZ	Dynamic braking module DBW04	-	-	-

- (1) Refer to the PLC module manual.
- (2) Refer to the Anybus-CC communication manual.
- (3) Refer to the programming manual.
- (4) Use DB-9 pin, male-to-female, straight-through cable (serial mouse extension type) for connecting the keypad to the inverter or Null-Modem standard cable. Maximum cable length: 10 m (33 ft).
Examples:
 - Mouse extension cable - 1.80 m (6 ft); Manufacturer: Clone.
 - Belkin pro series DB9 serial extension cable 5 m (17 ft); Manufacturer: Belkin.
 - Cables Unlimited PCM195006 cable, 6 ft DB9 m/f; Manufacturer: Cables Unlimited.
- (5) Inverters with serial number below 1011361739 use MMF-01 control card.
- (6) The MMF-03 module has a reserved space for the user (for example: write the application software version SoffPLC).

7.2.1 Use of External Dynamic Braking Module DBW03 and DBW04

The braking module can be added externally to any model, and especially to the models of frame sizes F, G and H, which do not feature built-in braking IGBT.

This module is connected to the DC link terminals and the braking resistor must be connected to the braking module terminals.

See electrical diagram example for the frame sizes F, G and H in [Figure 3.9 on page 3-20](#) and [Figure 3.10 on page 3-21](#).

See also DBW03 and DBW04 instructions manual for detailed information.

For frame sizes F and G it's recommended to use DBW03 model.

For frame size H it's recommended to use DBW04 model.



NOTE!

Dynamic braking in models from frame sizes F, G and H:

- For accessing the DC link connections it's necessary to remove top cover. See [Figure 3.13 on page 3-26](#).
- The maximum rms braking currents on DC link terminals of standard models in frame sizes F, G and H are the following:
 - Frame size F: 143 Amps-rms
 - Frame size G: 216 Amps-rms
 - Frame size H: rated DC current according [Table 8.2 on page 8-3](#).

8 TECHNICAL SPECIFICATIONS

This chapter describes the technical specifications (electric and mechanical) of frame sizes F, G and H of the CFW-11 inverter line.



8.1 POWER DATA

Power Supply:

- ☑ Voltage tolerance: -15 % to +10 % of the nominal voltage.
- ☑ Maximum rated voltage: 480 V for models 380...480 V for altitudes up to 2000 m (6.600 ft). For higher altitudes, the voltage derating will be 1.1 % for each 100 m (330 ft) above 2000 m (6.600 ft) - maximum altitude: 4000 m (13.200 ft).
- ☑ Frequency: 50/60 Hz (48 Hz to 62 Hz).
- ☑ Phase imbalance: $\leq 3\%$ of the rated phase-to-phase input voltage.
- ☑ Overvoltage according to Category III (EN 61010/UL 508C/IEC/EN 61800-5-1).
- ☑ Transient voltage according to Category III.
- ☑ Maximum of 60 connections per hour (1 per minute).
- ☑ Efficiency: typical value in nominal condition $\geq 98\%$; class IE2 according to IEC61800-9-2.
- ☑ Typical input power factor:
 - 0.94 for models with three-phase input in the rated condition.
- ☑ $\cos \phi$ (displacement factor): >0.98 .

Table 8.1 - Technical specifications of the CFW-11 inverter series frame sizes F, G and H models at rated switching frequencies

Model	Frame Size												
	F				G				H				
Use with Normal Duty (ND) Cycle	Number of Power Phases												
	3 Φ												
	Rated Output Current ⁽¹⁾	0242 T 4	0312 T 4	0370 T 4	0477 T 4	0515 T 4	0601 T 4	0720 T 4	0760 T 4	0795 T 4	0877 T 4	1062 T 4	1141 T 4
	Overload Current ⁽²⁾ [Arms]	242	312	370	477	515	601	720	760	795	877	1062	1141
	Rated Switching Frequency [kHz]	266	343	407	525	567	662	792	836	875	965	1168	1255
	Maximum Motor ⁽³⁾ [HP/kW]	363	468	555	716	773	900	1080	1140	1193	1316	1593	1712
	Rated Input Current	2	2	2	2	2	2	2	2	2	2	2	2
	Surface Mounting ⁽⁴⁾	200/150	250/185	300/220	400/300	400/300	500/370	600/440	650/480	700/515	750/560	950/700	1000/750
	Flange Mounting ⁽⁵⁾	242	312	370	477	515	601	720	760	795	877	1062	1141
	Use with Heavy Duty (HD) Cycle	Dissipated Power [W]	2651	3957	4578	6059	6490	7044	8532	10055	10993	12498	13558
Rated Output Current ⁽¹⁾		622	826	900	1227	1339	1584	1685	2008	2008	2008	2008	
Overload Current ⁽²⁾ [Arms]		211	242	312	370	477	515	560	600	637	715	855	
Rated Switching Frequency [kHz]		317	363	468	555	716	773	840	900	956	1073	1283	
Maximum Motor ⁽³⁾ [HP/kW]		422	484	624	740	954	1030	1120	1200	1274	1430	1710	
Rated Input Current		2	2	2	2	2	2	2	2	2	2	2	
Surface Mounting ⁽⁴⁾		175/132	200/150	250/185	300/220	400/300	400/300	450/330	500/370	550/400	600/440	750/560	800/590
Flange Mounting ⁽⁵⁾		211	242	312	370	477	515	560	600	637	715	855	943
Dissipated Power [W]		2296	3046	3829	4669	6005	6005	6589	7909	7824	8836	9916	11022
Surrounding Air Temperature [°C (°F)]		524	614	722	915	1232	1320	1253	1550	747	751	753	757
-10...45 °C (14...113 °F)													
-10...40 °C (14...104 °F)													
RFI Filter													
Built-in													
Weight [kg (lb)]													
Safety Stop													
Yes													
24 Vdc External Control Power Supply													
Yes													
Availability of Option Kits that can be Integrated into the Product (refer to the smart code in the Section 2.5 HOW TO SPECIFY THE CFW-11 MODEL (SMART CODE) on page 2-14)													
Yes													

Table 8.2 - Technical Specifications of frame sizes F, G and H DC version fed from 436 to 713 Vdc (equivalent to a rectified 380 to 480 Vac three-phase voltage) for switching

Model	Frame Size																																																																																																																																														
	F				G				H																																																																																																																																						
Number of Power Phases	DC																																																																																																																																														
	Rated Output Current ⁽¹⁾			Overload ⁽²⁾ [Arms]			Rated Switching Frequency [kHz]			Maximum Motor ⁽³⁾ [HP/kW]			Rated Input Current																																																																																																																																		
Use with Normal Duty (ND) Cycle	1 min			3 s			Surface Mounting ⁽⁴⁾			Flange Mounting ⁽⁵⁾			Surface Mounting ⁽⁴⁾			Flange Mounting ⁽⁵⁾																																																																																																																															
	242	312	370	477	515	601	720	760	795	877	1062	1141	266	343	407	525	567	662	792	836	875	965	1168	1255																																																																																																																							
Use with Heavy Duty (HD) Cycle	200/150			300/220			400/300			500/370			600/440			700/515			800/560			950/700			1000/750																																																																																																																						
	327	421	500	644	695	811	972	1026	1073	1184	1434	1540	2098	3228	3679	4866	5235	5543	6672	8070	7625	8502	9438	10229																																																																																																																							
Surrounding air Temperature [°C (°F)]	-10...45 °C (14...113 °F)			-10...45 °C (14...113 °F)			-10...45 °C (14...113 °F)			-10...45 °C (14...113 °F)			-10...45 °C (14...113 °F)			-10...45 °C (14...113 °F)			-10...45 °C (14...113 °F)			-10...45 °C (14...113 °F)																																																																																																																									
	RFI Filter												Built-in																																																																																																																																		
Availability of Option Kits that can be Integrated into the Product (refer to the smart code in the Section 2.5 HOW TO SPECIFY THE CFW-11 MODEL (SMART CODE) on page 2-14)	Weight [kg (lb)]												Safety Stop																																																																																																																																		
	97												100												102												107												151												151												156												156												213												213												220												220										
24 Vdc External Control Power Supply												Yes												Yes																																																																																																																							
CFW11 0242 T 4 ..DC..	CFW11 0312 T 4 ..DC..	CFW11 0370 T 4 ..DC..	CFW11 0477 T 4 ..DC..	CFW11 0515 T 4 ..DC..	CFW11 0601 T 4 ..DC..	CFW11 0720 T 4 ..DC..	CFW11 0760 T 4 ..DC..	CFW11 0795 T 4 ..DC..	CFW11 0877 T 4 ..DC..	CFW11 1062 T 4 ..DC..	CFW11 1141 T 4 ..DC..	CFW11 242 T 4 ..DC..	CFW11 312 T 4 ..DC..	CFW11 370 T 4 ..DC..	CFW11 477 T 4 ..DC..	CFW11 515 T 4 ..DC..	CFW11 601 T 4 ..DC..	CFW11 720 T 4 ..DC..	CFW11 760 T 4 ..DC..	CFW11 795 T 4 ..DC..	CFW11 877 T 4 ..DC..	CFW11 1062 T 4 ..DC..	CFW11 1141 T 4 ..DC..	CFW11 266 T 4 ..DC..	CFW11 343 T 4 ..DC..	CFW11 407 T 4 ..DC..	CFW11 525 T 4 ..DC..	CFW11 567 T 4 ..DC..	CFW11 662 T 4 ..DC..	CFW11 792 T 4 ..DC..	CFW11 836 T 4 ..DC..	CFW11 875 T 4 ..DC..	CFW11 965 T 4 ..DC..	CFW11 1168 T 4 ..DC..	CFW11 1255 T 4 ..DC..	CFW11 2098 T 4 ..DC..	CFW11 3228 T 4 ..DC..	CFW11 3679 T 4 ..DC..	CFW11 4866 T 4 ..DC..	CFW11 5235 T 4 ..DC..	CFW11 5543 T 4 ..DC..	CFW11 6672 T 4 ..DC..	CFW11 8070 T 4 ..DC..	CFW11 7625 T 4 ..DC..	CFW11 8502 T 4 ..DC..	CFW11 9438 T 4 ..DC..	CFW11 10229 T 4 ..DC..	CFW11 242 T 4 ..DC..	CFW11 312 T 4 ..DC..	CFW11 370 T 4 ..DC..	CFW11 477 T 4 ..DC..	CFW11 515 T 4 ..DC..	CFW11 601 T 4 ..DC..	CFW11 720 T 4 ..DC..	CFW11 760 T 4 ..DC..	CFW11 795 T 4 ..DC..	CFW11 877 T 4 ..DC..	CFW11 1062 T 4 ..DC..	CFW11 1141 T 4 ..DC..	CFW11 2098 T 4 ..DC..	CFW11 3228 T 4 ..DC..	CFW11 3679 T 4 ..DC..	CFW11 4866 T 4 ..DC..	CFW11 5235 T 4 ..DC..	CFW11 5543 T 4 ..DC..	CFW11 6672 T 4 ..DC..	CFW11 8070 T 4 ..DC..	CFW11 7625 T 4 ..DC..	CFW11 8502 T 4 ..DC..	CFW11 9438 T 4 ..DC..	CFW11 10229 T 4 ..DC..																																																																								

Technical Specifications

(1) Rated current in permanent duty under the following conditions:

- Recommended switching frequencies.
- For operation with a switching frequency of 2.5 kHz (applicable to models 242...760 A only), a 10 % derating must be applied to the current values specified in [Table 8.1 on page 8-2](#).
- For operation with a switching frequency of 5 kHz (applicable to models 242...760 A only), the rated output current must be derated according to [Table 8.3 on page 8-5](#).

It is not possible to use the CFW-11 inverter models with frames F, G and H with a switching frequency of 10 kHz.

- Ambient temperature around the inverter: -10 °C to 45 °C for models 242 A... 601 A and -10 °C to 40 °C for models 720 A... 1141 A. For operation of the inverter in environments with higher ambient temperatures around the inverter, refer to [Item 3.1.1 Environmental Conditions on page 3-1](#).
- Air relative humidity: 5 % to 90 % non-condensing.
- Altitude: 1000 m; above 1000 m up to 4000 m, output current derating of 1 % for each 100 m above 1000 m.
- Environment with pollution degree 2 (as per EN50178 and UL508C).

(2) One overload each 10 minutes. [Table 8.1 on page 8-2](#) contains just two points of the overload curve (activation time of 1 min and 3 s). The complete overload curves of the IGBTs for ND and HD are presented below.

Depending on the inverter operational conditions such as surrounding air temperature and output frequency, the maximum time for operation of the inverter with overload may be reduced.

(3) The motor outputs are only for guiding purposes for WEG motor 460 V, 4 poles. The proper sizing must be done according to the rated current of the motors used.

(4) The specified dissipated powers are valid for rated operating conditions, that is, for rated output current and switching frequency.

(5) The dissipated powers for flange mounting correspond to the total losses of the inverter minus the losses on the power modules (IGBT and rectifier).

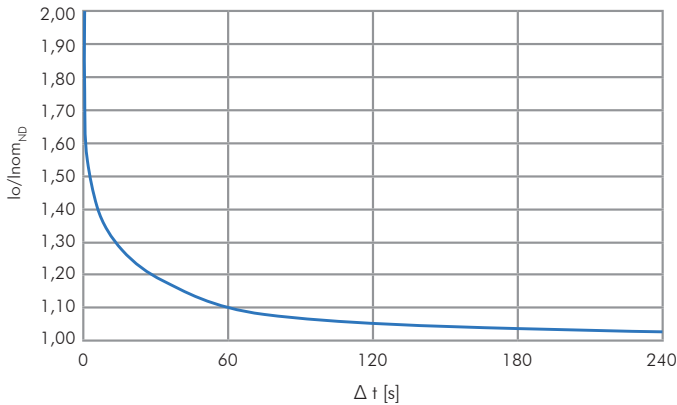

Attention!
One overload
each 10 minutes.

(a) IGBTs overload curve for the Normal Duty (ND) cycle

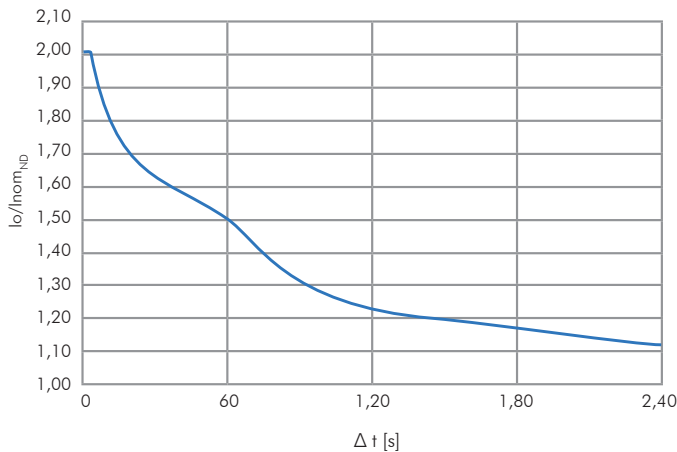

Attention!
One overload
each 10 minutes.

(b) IGBTs overload curve for the Heavy Duty (HD) cycle

Figure 8.1 - (a) and (b) - Overload curves for the IGBTs

Table 8.3 - Technical specifications of the CFW-11 inverter series frame sizes F and G models at 5 kHz switching frequency

Model		CFW11 0242T4	CFW11 0312T4	CFW11 0370T4	CFW11 0477T4	CFW11 0515T4	CFW11 0601T4	CFW11 0720T4	CFW11 0760T4	
Frame Size		F				G				
Number of Power Phases		3 ϕ								
Use with Normal Duty (ND) Cycle	Rated output current ⁽¹⁾ [Arms]	175	225	266	343	343	390	468	494	
	Overload Current [Arms]	1 min	193	248	293	377	377	429	515	543
		3 s	263	338	399	515	515	585	702	741
	Rated Switching Frequency [kHz]	5	5	5	5	5	5	5	5	
	Maximum Motor ⁽²⁾ [HP/kW]	150/110	175/132	200/150	270/200	270/200	300/220	400/300	400/300	
	Rated Input Current [Arms]	175	225	266	343	343	390	468	494	
	Dissipated Power [W]	Surface Mounting ⁽³⁾	2154	2770	3274	4222	4222	4801	5761	6081
Flange Mounting ⁽⁴⁾		819	1053	1245	1605	1605	1825	2190	2312	
Use with Heavy Duty (HD) Cycle	Rated Output Current ⁽¹⁾ [Arms]	152	175	225	266	318	335	364	390	
	Overload Current [Arms]	1 min	228	263	338	400	477	503	546	585
		3 s	304	350	450	532	636	670	728	780
	Switching Frequency [kHz]	5	5	5	5	5	5	5	5	
	Maximum Motor ⁽²⁾ [HP/kW]	125/90	150/110	175/132	200/150	250/185	270/200	300/220	300/220	
	Rated Input Current [Arms]	152	175	225	266	318	335	364	390	
	Dissipated Power [W]	Surface Mounting ⁽³⁾	1871	2154	2770	3274	3914	4124	4481	4801
Flange Mounting ⁽⁴⁾		711	819	1053	1245	1488	1568	1703	1825	
Surrounding Air Temperature [°C] ⁽¹⁾		-10...40 °C								
RFI Filter		Built-in								
Weight [kg (lb)]		130	132	135	140	204	207	215	215	
Availability of option kits that can be integrated into the product (refer to smart code in the Section 2.5 HOW TO SPECIFY THE CFW-11 MODEL (SMART CODE) on page 2-14)	Safety Stop	Yes								
	24 Vdc External Control Power Supply	Yes								

- (1) Steady state rated current in the following conditions:
- 5 kHz switching frequency.
 - Surrounding air temperature as specified in the table. For higher temperatures, limited to 50 °C (122 °F), the output current must be derated by 2 % for each °C above the maximum specified temperature.
 - Air relative humidity: 5 % to 90 % non-condensing.
 - Altitude: 1000 m (3,300 ft). Above 1000 m (3,300 ft) up to 4000 m (13,200 ft) the output current must be derated by 1 % for each 100 m (330 ft) above 1000 m (3,300 ft).
 - Ambient with pollution degree 2 (according to EN50178 and UL508C).
- (2) The motor outputs are only for guiding purposes for WEG motor 460 V, 4 poles. The proper sizing must be done according to the rated current of the motors used.
- (3) The dissipated powers are valid for rated operating conditions, that is, for rated output current and switching frequency.
- (4) The dissipated powers for flange mounting correspond to the total losses of the inverter minus the losses on the power modules (IGBT and rectifier).

8.2 ELECTRONICS/GENERAL DATA

Control	Method	<input checked="" type="checkbox"/> Voltage source <input checked="" type="checkbox"/> Type of control: - V/f (Scalar) - VVW: Voltage Vector Control - Vector control with encoder - Sensorless vector control (without encoder) <input checked="" type="checkbox"/> PWM SVM (Space Vector Modulation) <input checked="" type="checkbox"/> Full digital (software) current, flux, and speed regulators Execution rate: - current regulators: 0.2 ms (switching frequency of 2.5 kHz and 5 kHz), 0.25 ms (switching frequency = 2 kHz) - flux regulator: 0.4 ms (switching frequency of 2.5 kHz and 5 kHz), 0.5 ms (switching frequency = 2 kHz) - speed regulator / speed measurement: 1.2 ms
	Output frequency	<input checked="" type="checkbox"/> 0 to 3.4 x rated motor frequency (P0403). The rated frequency is programmable from 0 Hz to 300 Hz in the scalar mode and from 30 Hz to 120 Hz in the vector mode <input checked="" type="checkbox"/> Output frequency limits as a function of the switching frequency: - 125 Hz (switching frequency = 1.25 kHz) - 200 Hz (switching frequency = 2 kHz) - 250 Hz (switching frequency = 2.5 kHz) - 500 Hz (switching frequency = 5 kHz)
Performance	Speed control	V/f (Scalar): <input checked="" type="checkbox"/> Regulation (with slip compensation): 1 % of the rated speed <input checked="" type="checkbox"/> Speed variation range: 1:20 VVW: <input checked="" type="checkbox"/> Regulation: 1 % of the rated speed <input checked="" type="checkbox"/> Speed variation range: 1:30 Sensorless (P0202 = 3 induction motor): <input checked="" type="checkbox"/> Regulation: 0.5 % of the rated speed <input checked="" type="checkbox"/> Speed variation range: 1:100 Vector with Encoder (P0202 = 4 induction motor or P0202 = 6 permanent magnet): <input checked="" type="checkbox"/> Regulation: ±0.01 % of the rated speed with a 14-bits analog input (IOA) ±0.01 % of the rated speed with a digital reference (Keypad, Serial, Fieldbus, Electronic Potentiometer, Multispeed) ±0.05 % of the rated speed with a 12-bits analog input (CC11) <input checked="" type="checkbox"/> Speed variation range: 1:1000
	Torque control	<input checked="" type="checkbox"/> Range: 10 to 180 %, regulation: ±5 % of the rated torque (P0202 = 4, 6 or 7) <input checked="" type="checkbox"/> Range: 20 to 180 %, regulation: ±10 % of the rated torque (P0202 = 3, above 3 Hz)
Inputs (CC11 Board)	Analog	<input checked="" type="checkbox"/> 2 isolated differential inputs; resolution of AI1: 12 bits, resolution of AI2: 11 bits + signal, (0 to 10) V, (0 to 20) mA or (4 to 20) mA, impedance: 400 kΩ for (0 to 10) V, 500 Ω for (0 to 20) mA or (4 to 20) mA, programmable functions
	Digital	<input checked="" type="checkbox"/> 6 isolated digital inputs, 24 Vdc, programmable functions
Outputs (CC11 Board)	Analog	<input checked="" type="checkbox"/> 2 isolated outputs, (0 to 10) V, $R_I \geq 10 \text{ k}\Omega$ (maximum load), 0 to 20 mA / 4 to 20 mA ($R_I \leq 500 \Omega$) resolution: 11 bits, programmable functions
	Relay	<input checked="" type="checkbox"/> 3 relay outputs with NA/NF (NO/NC), 240 Vac, 1 A, programmable functions
Safety	Protection	<input checked="" type="checkbox"/> Output overcurrent/short-circuit <input checked="" type="checkbox"/> Under/Overvoltage <input checked="" type="checkbox"/> Phase loss <input checked="" type="checkbox"/> Overtemperature <input checked="" type="checkbox"/> Braking resistor overload <input checked="" type="checkbox"/> IGBTs overload <input checked="" type="checkbox"/> Motor overload <input checked="" type="checkbox"/> External fault/alarm <input checked="" type="checkbox"/> CPU or memory fault <input checked="" type="checkbox"/> Output phase-ground short-circuit
Integral keypad (HMI)	Standard keypad	<input checked="" type="checkbox"/> 9 operator keys: Start/Stop, Up arrow, Down arrow, Direction of rotation, Jog, Local/Remote, Right soft key and Left soft key <input checked="" type="checkbox"/> Graphical LCD display <input checked="" type="checkbox"/> View/edition of parameters <input checked="" type="checkbox"/> Indication accuracy: - current: 5 % of the rated current - speed resolution: 1 rpm <input checked="" type="checkbox"/> Possibility of remote mounting
Enclosure	IP20	<input checked="" type="checkbox"/> Standard
	IP00	<input checked="" type="checkbox"/> Special DC hardware
	IP54	<input checked="" type="checkbox"/> Back of the inverter (external part for flange mounting) ⁽¹⁾
PC connection for inverter programming	USB connector	<input checked="" type="checkbox"/> USB standard Rev. 2.0 (basic speed) <input checked="" type="checkbox"/> Type B (device) USB plug <input checked="" type="checkbox"/> Interconnection cable: standard host/device shielded USB cable

(1) They need special hardware H1.

8.3 CODES AND STANDARDS

Safety standards	<ul style="list-style-type: none"> ☑ UL 508C - power conversion equipment Note: suitable for Installation in a compartment handling conditioned air. ☑ UL 840 - insulation coordination including clearances and creepage distances for electrical equipment ☑ EN61800-5-1 - safety requirements electrical, thermal and energy ☑ EN 50178 - electronic equipment for use in power installations ☑ EN 60204-1 - safety of machinery. Electrical equipment of machines. Part 1: general requirements Note: the final assembler of the machine is responsible for installing an safety stop device and a supply disconnecting device ☑ EN 60146 (IEC 146) - semiconductor converters ☑ EN 61800-2 - adjustable speed electrical power drive systems - part 2: general requirements - rating specifications for low voltage adjustable frequency AC power drive systems
Electromagnetic compatibility (EMC)	<ul style="list-style-type: none"> ☑ EN 61800-3 - adjustable speed electrical power drive systems - part 3: EMC product standard including specific test methods ☑ CISPR 11 - Industrial, scientific and medical (ISM) radio-frequency equipment – electromagnetic disturbance characteristics - Limits and methods of measurement ☑ EN 61000-4-2 - electromagnetic compatibility (EMC) - part 4: testing and measurement techniques - section 2: electrostatic discharge immunity test ☑ EN 61000-4-3 - electromagnetic compatibility (EMC) - part 4: testing and measurement techniques - section 3: radiated, radio-frequency, electromagnetic field immunity test ☑ EN 61000-4-4 - electromagnetic compatibility (EMC) - part 4: testing and measurement techniques - section 4: electrical fast transient/burst immunity test ☑ EN 61000-4-5 - electromagnetic compatibility (EMC) - part 4: testing and measurement techniques - section 5: surge immunity test ☑ EN 61000-4-6 - electromagnetic compatibility (EMC)- part 4: testing and measurement techniques - section 6: Immunity to conducted disturbances, induced by radio-frequency fields ☑ EN 61000-4-11 - Testing and measurement techniques - Voltage dips, short interruptions and voltage variations immunity tests
Mechanical standards	<ul style="list-style-type: none"> ☑ EN 60529 - degrees of protection provided by enclosures (IP code) ☑ UL 50 - enclosures for electrical equipment ☑ IEC 61800-5-1 – adjustable speed electrical power drive systems - part 5-1: safety requirements - electrical, thermal and energy Level 10 Hz to 57 Hz – 0,075 mm of range 57 Hz to 150 Hz – 1g

8.4 CERTIFICATIONS

Certifications (*)	Notes
UL and cUL	E184430
CE	
IRAM	
C-Tick	
EAC	
ABS	<p>Link: http://ww2.eagle.org/en/rules-and-resources/type-approval-database.html After accessing the link, click on "Select Option" and select "Data Search". On the new window, the certificate number must be entered on the "Certificate Number" field: 15-RJ2890495. Click on "Search".</p>
Functional Safety	STO Funtion, with certificate issued by TÜV Rheinland.

(*) For updated information on certifications, please, contact WEG.

8.5 MECHANICAL DATA

Frame Size F

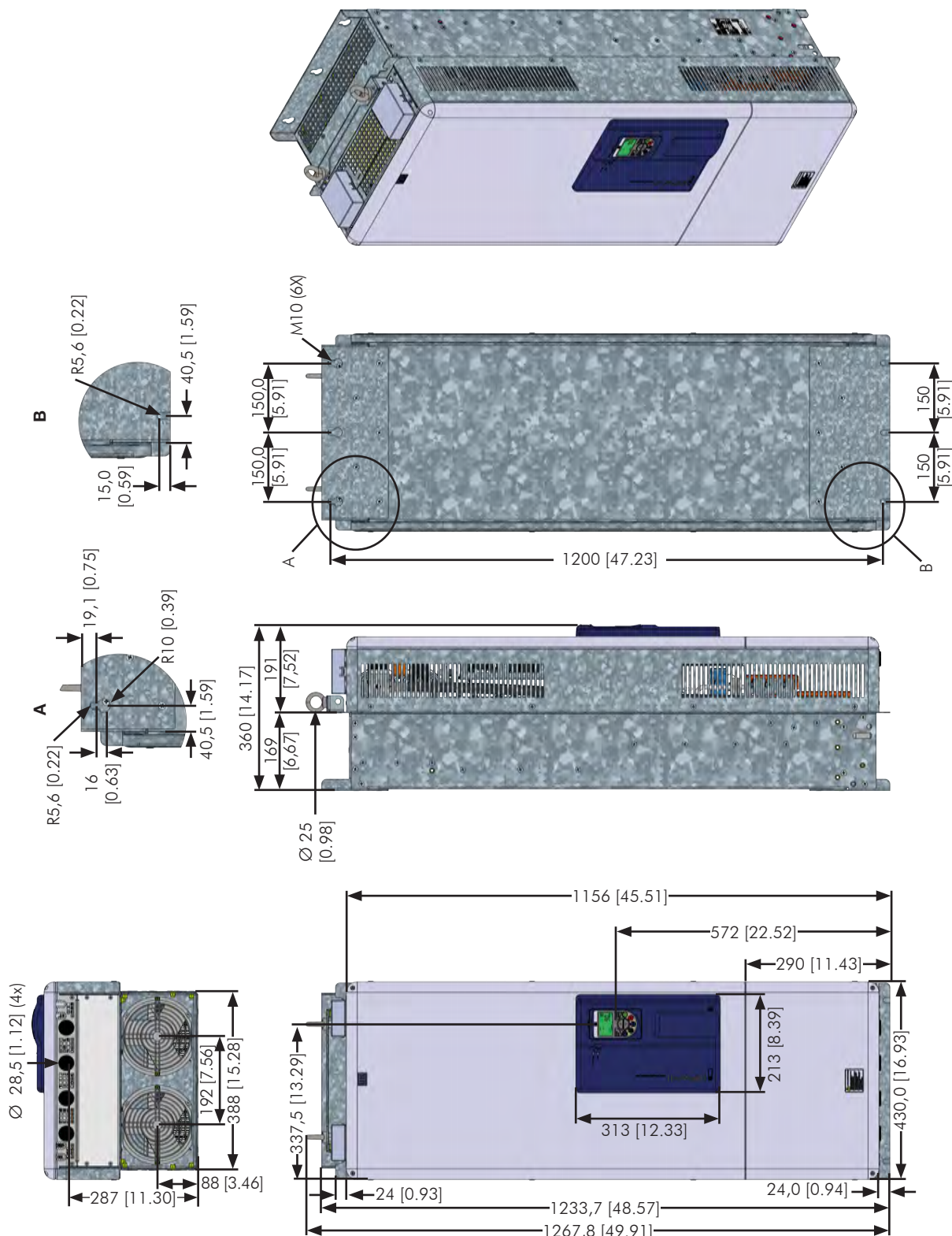

Figure 8.2 - Frame size F dimensions - mm [in]

Frame Size G

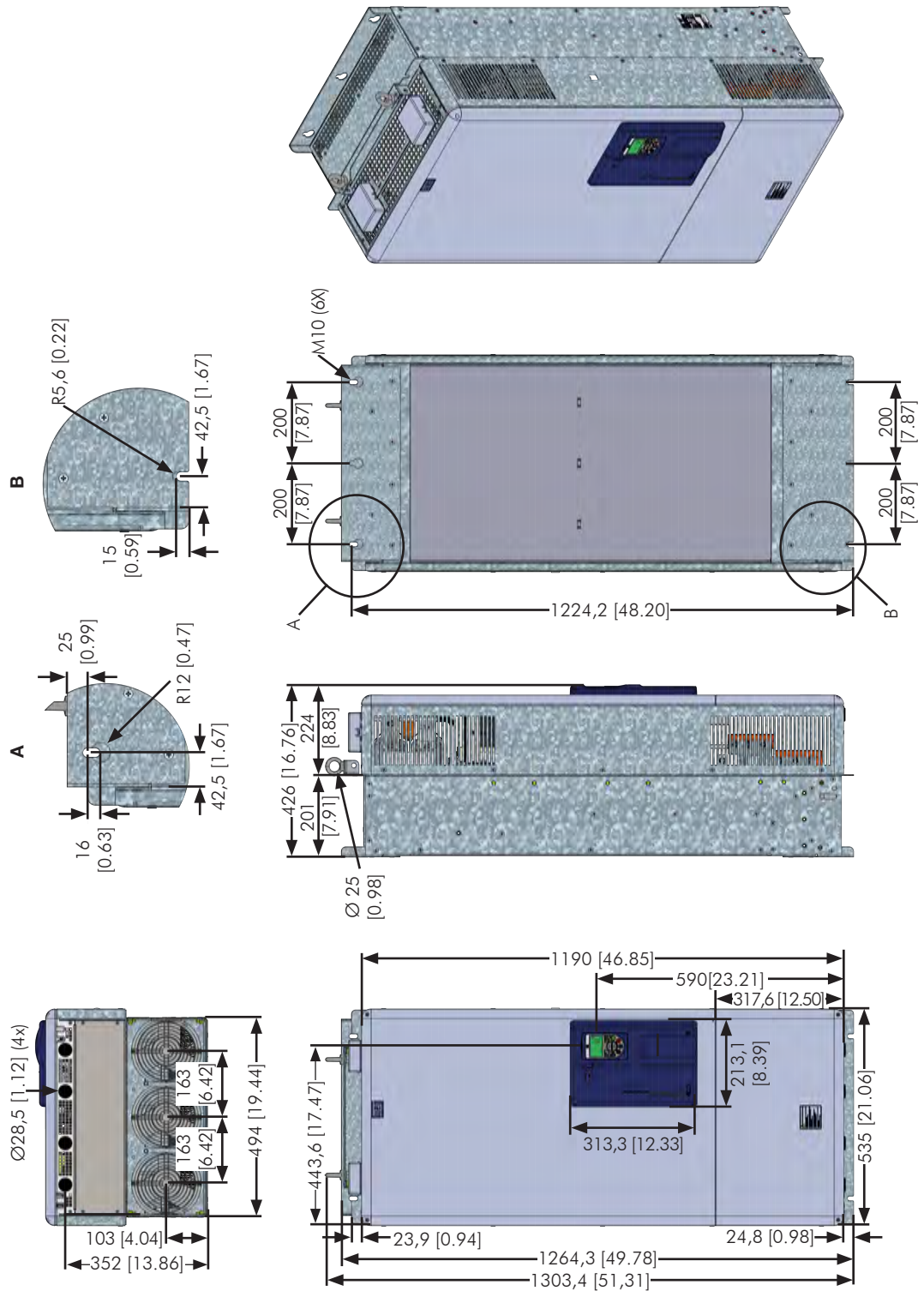

Figure 8.3 - Frame size G dimensions - mm [in]

Frame Size H

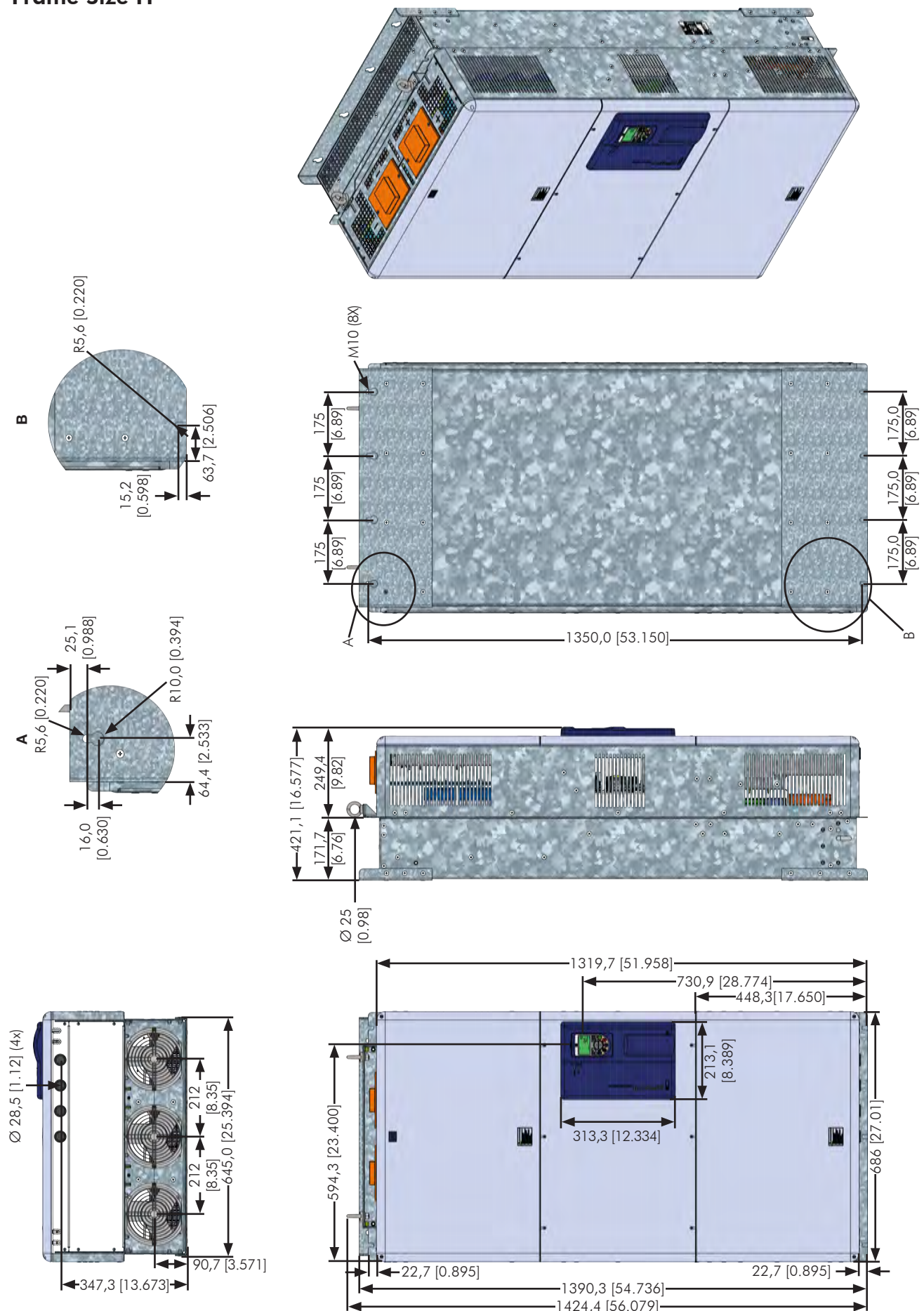

Figure 8.4 - Frame size H dimensions - mm [in]