

1 2 3 4 5 6

A

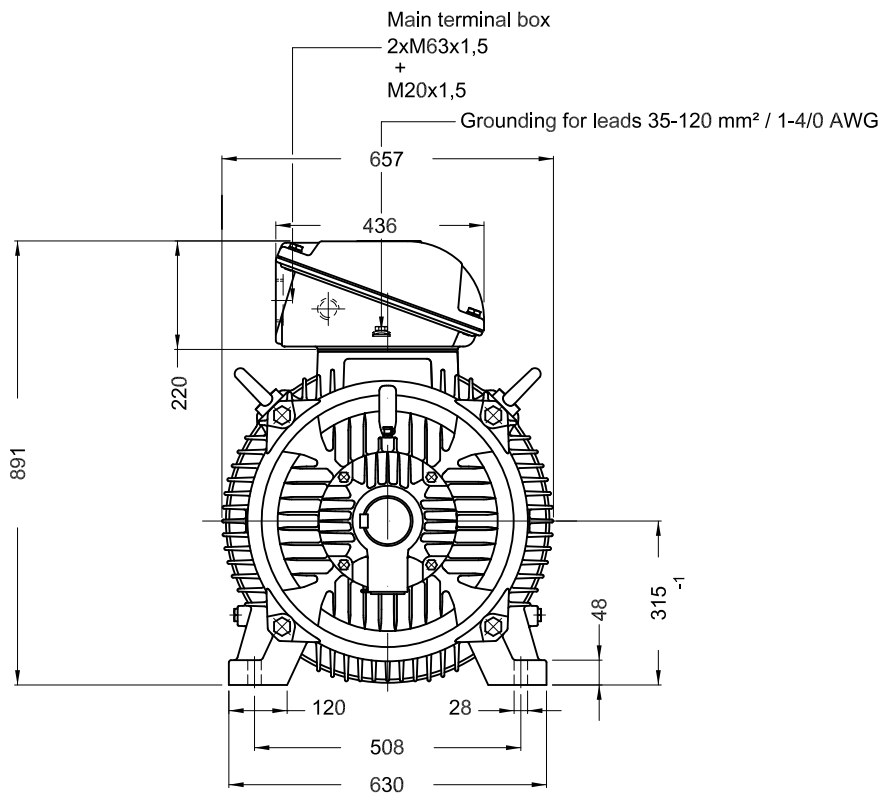

B

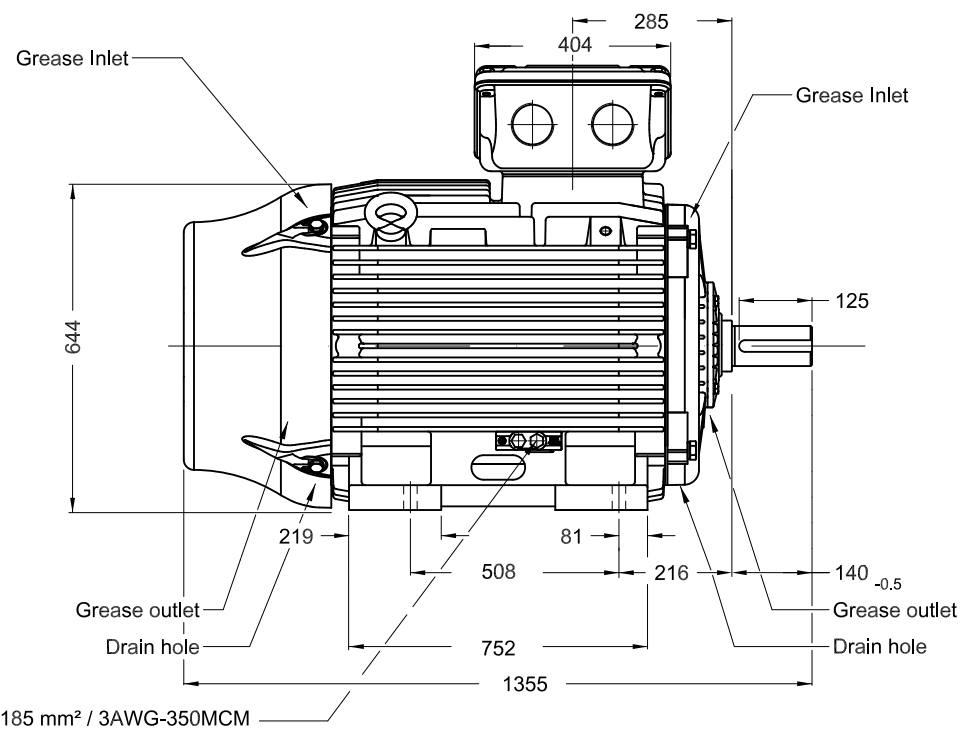

C

D

E

Without vertical jackscrews
NDE endshield with electrically insulated bearing hub
Color RAL 5009
Painting plan 203A
Mounting B3T

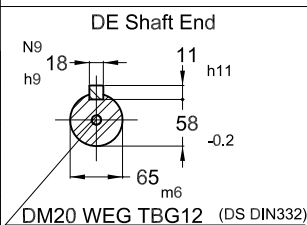

200 kW 02 Poles 50 Hz A

ECM	LOC	SUMMARY OF MODIFICATIONS	EXECUTED	CHECKED	RELEASED	DATE	VER
EXECUTED	PIRBUSER	THREE PHASE W22 MOTOR - PREMIUM EFF					
CHECKED		FRAME 315L IP55 TEFC					
RELEASED							
REL DT.	WMO	Jaragua do Sul	Product Engineering	SHEET	1 / 1		

PREVIEW
WDD

