



Compatível com disjuntores-motores MPW25 e MPW40 a partir da versão "V1A" e "V0A" respectivamente.

Compatible with motor-protective-circuit-breaker MPW25 and MPW40 from version "V1A" and "V0A" respectively.

Compatible con guardamotores MPW25, y MPW40 a partir de la versión "V1A" e "V0A" respectivamente..

RMMP und RMMP-E kann mit Motorschutzschalter MPW25, und MPW40 ab Version "V1A" und "V0A" eingesetzt werden.

INSTRUÇÕES DE MONTAGEM ASSEMBLY INSTRUCTIONS INSTRUCCIONES DE MONTAJE MONTAGEANLEITUNG

0757.2336.10

Manopla Rotativa para montagem em painel MPW25 e MPW40 (RMMP / RMMP-E)
Door Coupling Rotary Handle MPW25 and MPW40 (RMMP / RMMP-E)
Manija Rotativa para Purta de Tableros MPW25 y MPW40 (RMMP / RMMP-E)
Türkupplungsgriff MPW25 und MPW40 (RMMP / RMMP-E)



Montagem MPW25 e MPW40 / MPW25 and MPW40 Assembly
Montaje MPW25 y MPW40 / Einbaulage MPW25 und MPW40

Vertical
Vertical
Vertical
Vertical

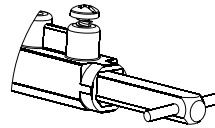

Horizontal
Horizontal
Horizontal
Horizontal

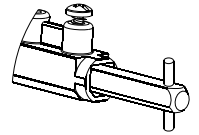

Fixação do Suporte / Fastening of the Support
Fijacion del Soporte / Befestigungsvorrichtung aufkleben

A tentativa de abertura do painel com MPW na posição "I", danificará o disjuntor.
The attempt of opening of the panel with the MPW in the "I" position, will damage the circuit breaker.
La tentativa de la abertura del panel con MPW en la posición "I", dañará el interruptor.
Der Versuch der Öffnung der Schaltschrankes mit dem MPW in der Pos. "I", beschädigt den Leistungsschalter.

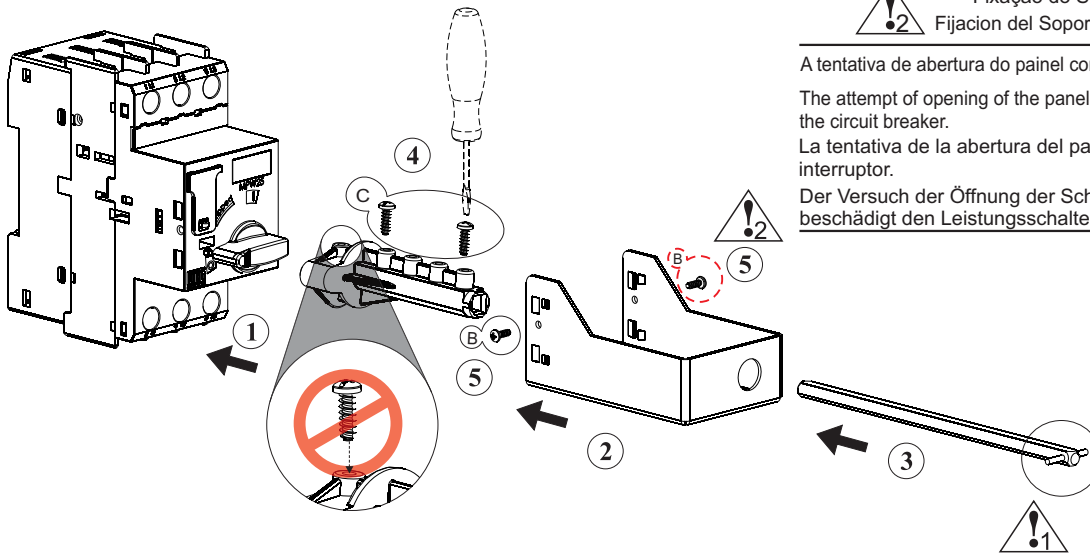

Furação da porta do painel
Drilling the panel door
Agujero en la puerta de tableros
Bohren der Schaltschranktür

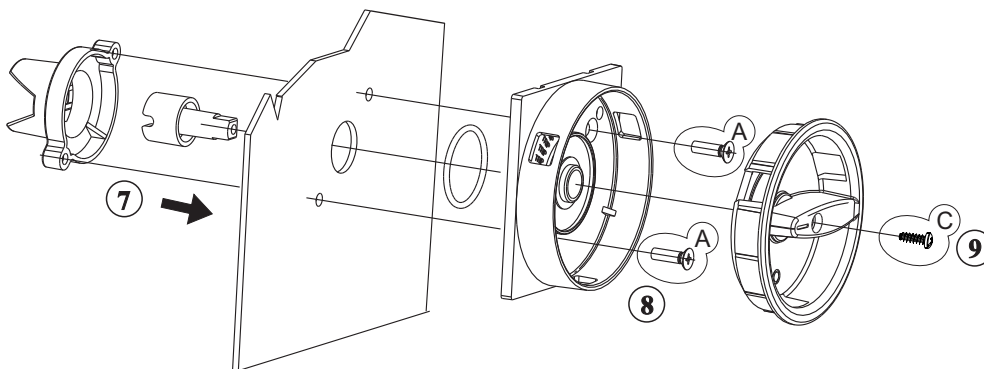
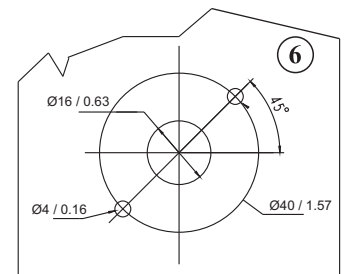

2	A		PHILLIPS #2 Ø3.5 X 10mm
2	B		PHILLIPS #1 Ø2.2 X 6mm
3	C		PHILLIPS #1 Ø3 X 10mm

Dimensão mínima para corte do eixo (mm)
Minimum dimension for cut the shaft (mm)
Dimensiones mínimas para corte del eje (mm)
Mindestmaß für das Kürzen der Achse (mm)

Dimensões
Dimensions
Dimensiones
Maße

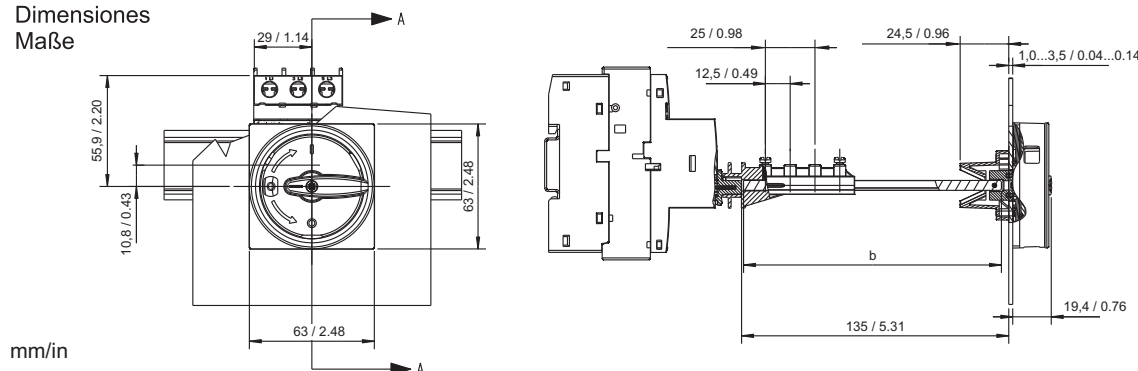

b (mm / in)	Possibilidade de ajuste Possible adjustment Posibilidad del ajuste Mögliche Einstellung
130 / 5.12	130 / 5.12...155 / 6.10
330 / 12.99	330 / 12.99...355 / 13.98

- Atenção / Warning / Atención / Warnung

A porta do painel só poderá ser aberta com o MPW na posição "O"
The panel door can be opened only with the MPW in the "O" position
Apertura de la puerta del tablero solamente con MPW en la posición desconectado
Die Schaltschranktür kann nur bei Pos. "O" MPW geöffnet werden

WEG Automação
www.weg.net