

Yaskawa GA500 Frequency Inverter Easy Start Guide



The Yaskawa GA500 Frequency Inverter range is available to order from inverterdrive.com

This guide is intended to complement the user manual provided by the manufacturer. It is provided as a basic introduction to the product for Inverter Drive Supermarket customers. It should not be used as a replacement for the manual issued by the manufacturer.



This product is not a safety device. All safety considerations including but not limited to Emergency Stop provision should be assessed separately and are outside the scope of this guide.

Contents

Page 1	Contents
Page 2	Power and Motor Connections (Single Phase)
Page 3	Power and Motor Connections (Three Phase)
Page 4	Motor Connections - Star and Delta
Page 5	Parameters - Overview Parameters to set before use
Page 6	How to set a Parameter value
Page 7	How to operate the Inverter from the keypad
Page 8	How to enable Sensorless Vector Mode
Page 9	How to connect and configure a Potentiometer for remote speed control
Page 10	How to connect and configure a Run Forward or Run Reverse switch
Page 11	How to connect and configure a Run/Stop switch with Forward/Reverse selection
Page 12	How to configure “3-Wire” control with Run Forward Run Reverse and Stop pushbuttons
Page 13	Brake Resistor Connection
Page 14	STO (Safe Torque Off) Connections
Page 15	How to Reset the Inverter to Factory Defaults

1. Power and Motor Connections (Single Phase)



Before commencing, confirm that the inverter and all cables are completely isolated from the power supply, have been isolated for at least 5 minutes and that the motor is not turning.

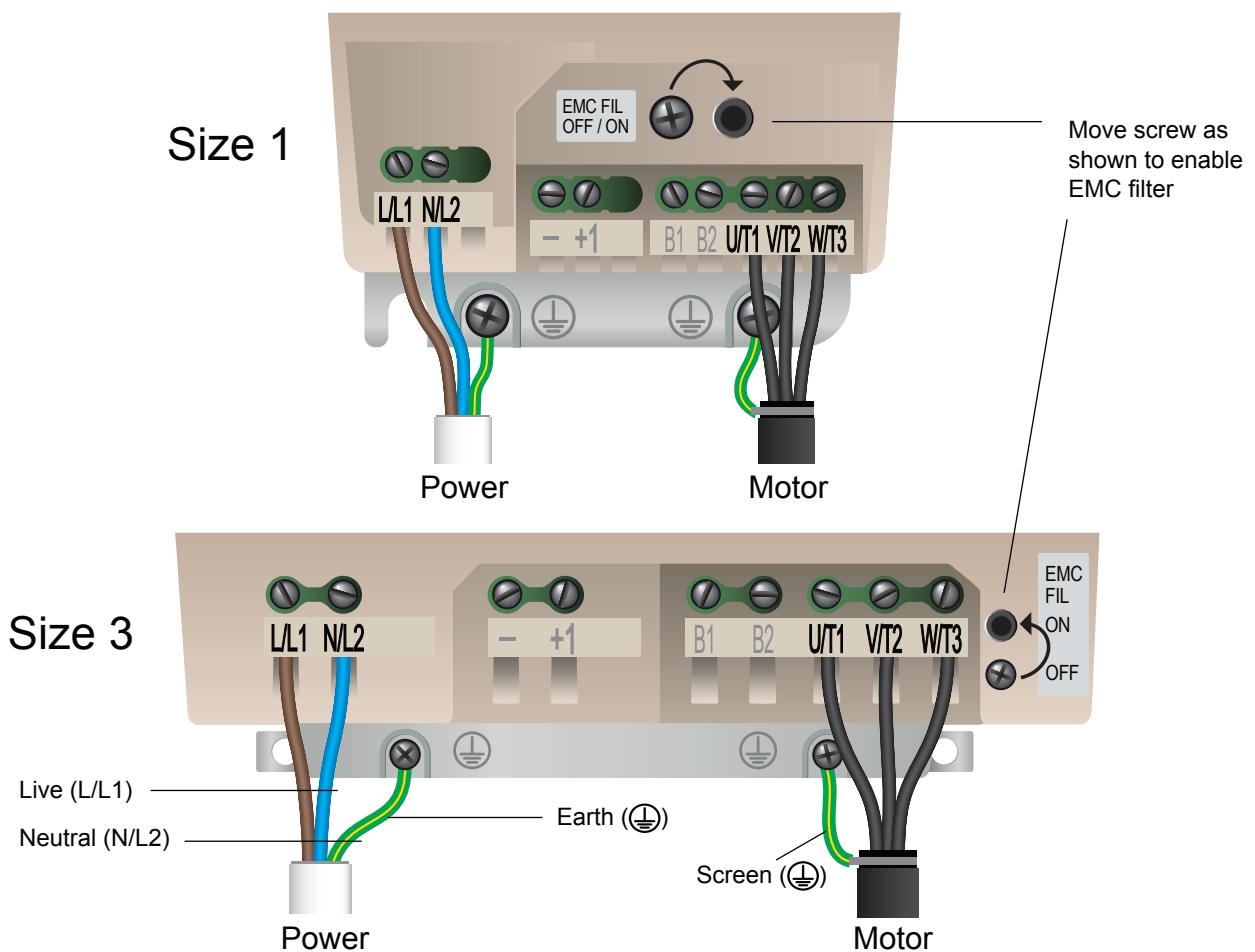

Notes:

The illustrations above show the 0.2kW-0.4kW (size 1) and 0.75kW-2.2kW (size 3) ratings. The arrangement for the 4kW rating (size 4, not shown) is different but uses the same labelling scheme.

Some power and motor terminals may be covered by stickers. The messages on these stickers should be read and understood before they are removed.

Important:

The supply must match the Inverter specification and the motor must be separately and permanently earthed.

The order of the three motor phases determines the initial direction the motor turns. This can be reversed by swapping any two phases or changing the inverter parameters.

Use screened cable between the Inverter and Motor and ensure the screen is grounded as shown.

Easy Start Guide

Yaskawa GA500 Frequency Inverter

2. Power and Motor Connections (Three Phase)



Before commencing, confirm that the inverter and all cables are completely isolated from the power supply, have been isolated for at least 5 minutes and that the motor is not turning.

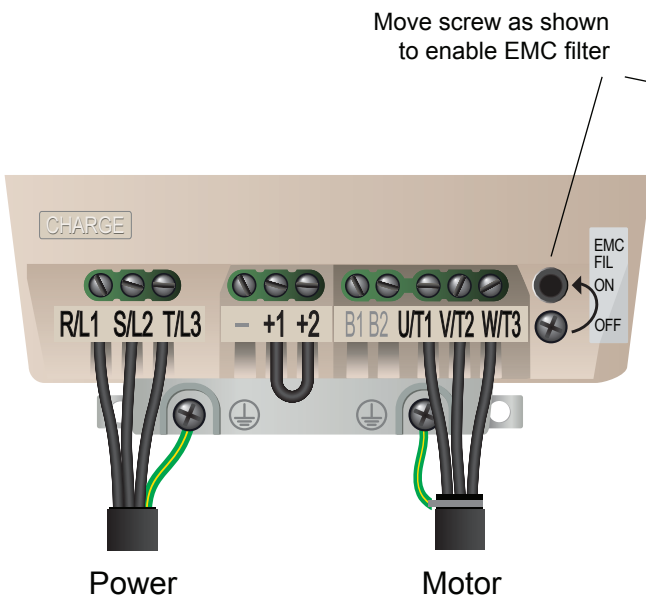

Size 2

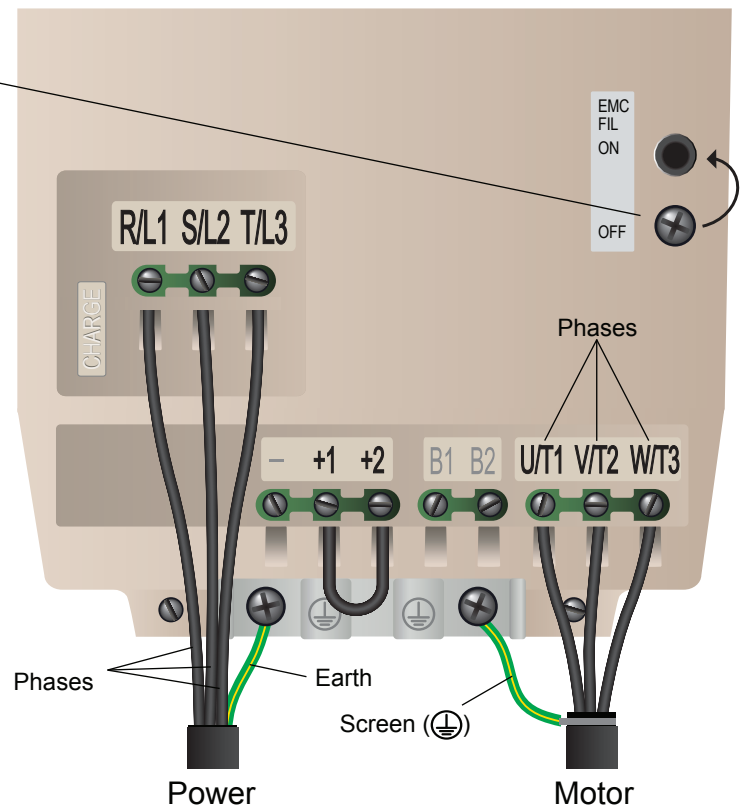

Size 5

Notes:

The illustrations above show the 5.5kW-7.5kW 400V (size 2) and 11kW-15kW 400V (size 5) ratings. Other sizes have the same labelling scheme but may have different terminal positions.

Some terminals may be covered by plastic tabs. These terminals are not used for power and motor connections and do not need to be removed!

Important:

Connect the three supply (power) phases to terminals R/L1, S/L2 and T/L3. The order is not important.

Connect the three motor phases to terminals U/T1, V/T2 and W/T3. The order determines the initial direction the motor turns. This can be reversed by swapping any two phases or changing the inverter parameters.

Use screened cable between the Inverter and Motor and ensure the screen is grounded as shown.

3. Motor Connections - Star and Delta

Dual voltage induction motors typically include terminal boxes with six points. The points can be connected together with links in one of two ways to suit one of the two rated voltages.

The two ways of connecting the links are shown below. These are known as “Star” (the higher voltage) or “Delta” (the lower voltage).

The selection of Star or Delta is not optional and must match the supply voltage.

Dual voltage motor name plates include symbols to represent voltage and full load current in each configuration. Delta is represented by a triangle and Star by a Y (Wye).

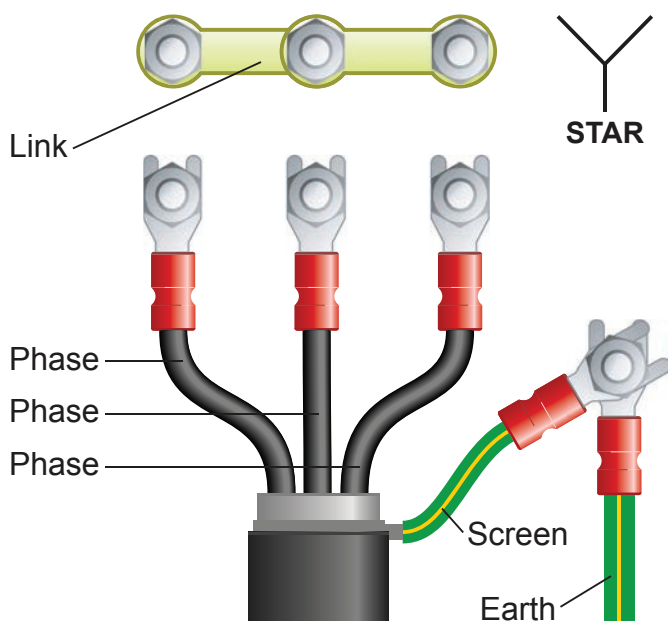

3.1 Motor connected in STAR (or Wye):

For safety purposes, Star (shown opposite is the default configuration for small motors (usually to 3kW) and is sometimes known as “two at one side”.

Only two links are required for Star. Double-up the links if changing from Delta to allow the motor to be changed back in future.

The order of the three phases determines the direction the motor turns.

Note that the manufacturer recommends that the cable screen is earthed at both ends and the motor and inverter are permanently and separately earthed.

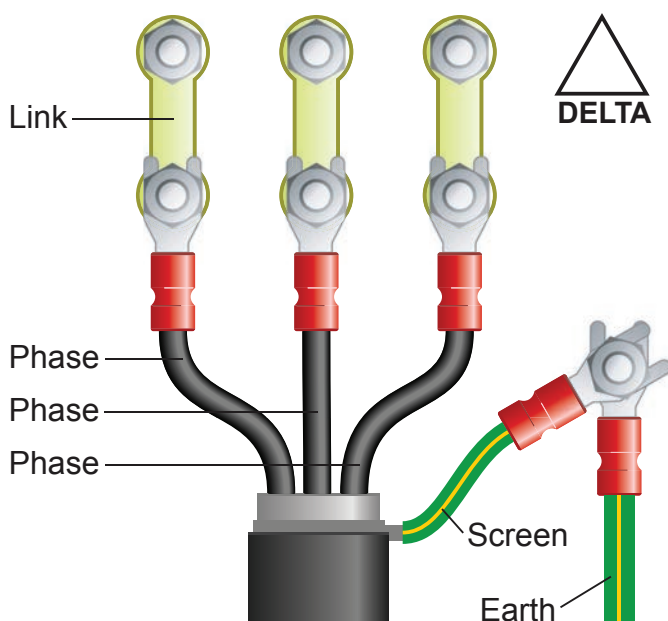

3.2 Motor connected in DELTA:

The link configuration is shown in the illustration opposite and is sometimes referred to as “three-a-breast”.

The order of the three phases determines the direction the motor turns.

Note that the manufacturer recommends that the cable screen is earthed at both ends and the motor and inverter are permanently and separately earthed.

4. Parameters - overview

The Inverter contains a number of settings which can be changed to tailor it for use in a wide range of applications. These settings are known as parameters.

Parameters are typically referred to by a letter and number (eg. E2-01 = Motor Rated Current) with a description available in the manual.

The parameters contain critical information essential to the correct operation of the Inverter. Therefore, they should at least be checked by the user before the Inverter is operated for the first time.

The parameters listed below are intended to provide a starting point to allow for basic operation of the GA500 Inverter.

5. Parameters to set before use

Set the following parameters to allow the GA500 to control a motor with Run, Stop and Speed Control from the keypad.

If any of the parameters have been changed previously, follow the procedure in section 15 to reset the Inverter to Factory Defaults.

See section 6 to learn how to set a parameter value

5.1 Parameters to check and values to set

Parameter	Description	How to Set
5FUP→A 1-02	Control Method Type	Default is 0 for V/F control and will suit many applications. If required, change to 2 for Sensorless Vector Control. This selection will determine the values of E1-04 to E1-13.
5FUP→b 1-01	Frequency Reference	Default is 1 for Analogue Input. Sets the frequency (speed) reference source when in remote control. Default is used in this guide.
5FUP→b 1-02	Run Command	Default is 1 for Digital Inputs. Sets the Run/Stop signal source when in remote control. Default is used in this guide.
5FUP→b 1-03	Stopping Method	Default is 0 for ramp to stop and will decelerate the load in the time set in C1-02. Change to 1 for coast to stop which will allow the load to stop in its own time.
5FUP→C 1-01	Acceleration Time (s)	Default is 10 seconds; increase or decrease if faster or slower acceleration is required.
5FUP→C 1-02	Deceleration Time (s)	Default is 10 seconds; increase or decrease if faster or slower deceleration is required.
5FUP→CG-01	Normal / Heavy Duty Selection	Default is 0 which will suit constant torque (Heavy Duty) loads. Change to 1 for fan and centrifugal pump (Normal Duty) loads.
5FUP→CG-02	Carrier Frequency (kHz)	Default is determined by the drive rating and will suit most applications.
5FUP→E 1-01	Input Voltage (V)	Default is rating-dependent; set to the power supply voltage eg. 230 or 400 volts.
5FUP→E 1-03	V/F Pattern (only applies if A1-02 is set to 0)	Set to 0F for 50Hz motor. By selecting this pattern parameters E1-04 to E1-13 are automatically adjusted.
5FUP→E2-01	Motor Rated Current (A)	Default is rating dependent. Set to match motor name plate. Do not exceed GA500 rating.
5FUP→E2-04	Number of Motor Poles	Default is 4. Set to match motor eg. approx 1400rpm = 4 pole, approx 2800 = 2 pole.
5FUP→E2-11	Motor Rated Power (kW)	Default is rating dependent. Set to match motor nameplate. Do not exceed GA500 rating.

6. How to set a Parameter Value



6.1 Default display

When first powered up the GA500 will display the speed setpoint in Hz.

Note this is F 0.00 by default but may change once setup has been completed.



6.2 Select the parameter list

The GA500 has two groups containing parameters; STuP and PAr. STuP contains a limited number of setup parameters whilst PAr contains all parameters organised in groups. In this example we will set parameter E2-01 motor rated current, which can be found in both PAr and STuP. From the default display of F 0.00, use the \uparrow and \downarrow keys to select PAr (which will flash). Then, press \leftarrow to select it.



6.3 Select the parameter

The display will now show A1-01 with the “A” digit flashing to indicate that it is selected. Use the \uparrow key to change this to “E”. Then, use the \rightarrow key to select the next digit. “1” will now flash to indicate that it is selected. Use the \uparrow key to change it to “2”. The display will now show E2-01. Press \leftarrow or the \rightarrow key to select “01”. These last two digits do not need to be changed so press \leftarrow again to edit the parameter value.



6.4 Change the parameter value and save

Use the \leftarrow and \rightarrow keys to select each digit changing the value with \uparrow and \downarrow as required. In this case we have changed the value to match our motor nameplate which states a rated current of 3.08A. This is an example. Set to match your motor details.

Press the \leftarrow key to save changes. The display will briefly show “End” before returning to the parameter group. Press ESC to return to PAr and ESC again for F 0.00.

7. How to operate the Inverter from the keypad









7.1 Default display

When first powered up the GA500 will display F 0.00 (unless the speed setpoint has been changed). The READY indicator will also be illuminated in blue.

As default, the GA500 is set to operate in remote control (via the IO terminals). To select local control (operator keypad) press the “LO/RE” key. The indicator next to the “LO/RE” key will illuminate in green when in local control.



7.2 Set the speed reference







Press  to edit F 0.00 then use the  and  keys to select each flashing digit changing it with  and  as required. In this example we have changed the value to 25.00Hz. Press  to save. “End” will briefly be displayed. Press “ESC” and the digit will stop flashing.

Note: If the default value of 0.00 is not changed the motor will not turn when “RUN” is pressed and the green indicator on the “RUN” key will flash.



7.3 Press the green “RUN” key to start the motor

The RUN key will start the motor and the RUN lamp will illuminate in green when the motor is running.

To change the speed whilst running, press  to edit the setpoint and use the  and  keys to select each digit, changing it with  and  as in step 7.2 above. Note that the new setpoint will not apply until  is pressed to save it. In this example will have changed the value to 26.00Hz.



7.4 Press the red “STOP” key to stop the motor

The STOP key will stop the motor. The RUN lamp will flash whilst the motor is decelerating and go off once stopped.

Note: if the GA500 is switched off in local control (operator keypad) it will return to remote control (via IO terminals) when powered back on. If keypad only control is required set b1-01 and b1-02 to 0.

8. How to enable Sensorless Vector Mode

The standard operating mode of the GA500 Inverter is VxV. This is the simplest form of operation and controls Volts and Frequency to vary the speed of a standard Induction Motor. The GA500 can also operate in Sensorless Vector mode. This can improve motor performance without requiring a separate feedback device.

To enable Sensorless Vector mode, parameters must be correctly set and an “auto-tune” performed to build a “model” of the motor. The process is described below.

Note: Sensorless Vector is not suitable where the motor rating is significantly lower than the Inverter rating or where more than one motor is being controlled.

8.1 Parameters to check and values to set for a constant torque (heavy duty) load

Parameter	Description	How to Set
PRr → R 1-02	Control Method Selection	Default is 0 for V/f; change to 02 for open loop (sensorless) vector.
PRr → C6-01	Application	Default is 0; default is required for heavy duty load.
RFUn → F 1-01	Auto-Tune Mode Selection	Default is 0 for rotational auto-tune; default is required for this example.
RFUn → F 1-02	Motor Rated Power (kW)	Set to match motor nameplate.
RFUn → F 1-03	Motor Rated Voltage (V)	Set to match motor nameplate - normally 230V or 400V.
RFUn → F 1-04	Motor Rated Current (A)	Set to match motor nameplate.
RFUn → F 1-05	Motor Base Frequency (Hz)	Set to match motor nameplate - normally 50Hz for Europe.
RFUn → F 1-06	Number of Motor Poles	Default is 4; change for 8 pole, 6 pole, 2 pole etc.
RFUn → F 1-07	Base Speed (rpm)	Default is 1450; Set to match motor nameplate rpm (or min ⁻¹).



8.2 Start Autotune

Once the parameters in 8.1 have been set and with parameter F 1-07 still visible, press the Δ key twice. The display will show “RUN10” to indicate that it is ready to start the auto-tune.

Important! Ensure that the motor is unloaded - ie. that it is decoupled from the load and “bare shaft” before starting the auto-tune.



8.3 The Autotune Process

Press the “RUN” key to start the auto tune. The motor shaft will turn, the GA500 display will flash “Run10” and the “RUN” lamp will illuminate. Once complete, the display will briefly show “End” and the run and ready lights will go off.

Note: An incomplete auto-tune will return an Er-XX error message or EndX alarm message. This is normally because the motor values are incorrect or the motor does not match the GA500 rating.

9. How to connect and configure a Potentiometer for remote speed control

If speed control via the integrated keypad is unsuitable for the application, a remote Potentiometer can be used instead. This provides the benefit of allowing motor speed to be controlled from a more convenient location such as a cabinet door or on the machine itself.

A potentiometer rated at 2kOhm is recommended by the manufacturer. The number of turns depends on the application. Both single and multiturn Potentiometers are available from us at InverterDrive.com.

When powered up with no parameter changes the GA500 is configured for this operation.

9.1 Parameters to check for remote Potentiometer speed control

Parameter	Description	How to Set
PR → b1-01	Frequency Reference	Default is 1 for Analogue Input AI1. Default value is required for this example.
PR → d2-01	Freq Reference Upper Limit (%)	Default is 100%. This is a percentage of parameter E1-04 which is 50Hz by default.
PR → d2-02	Freq Reference Lower Limit (%)	Default is 0%. This is a percentage of parameter E1-04 which is 50Hz by default.
PR → E1-04	Max Output Frequency (Hz)	Default is 50 Hz. If this is changed it increases or decreases the speed range of the potentiometer.

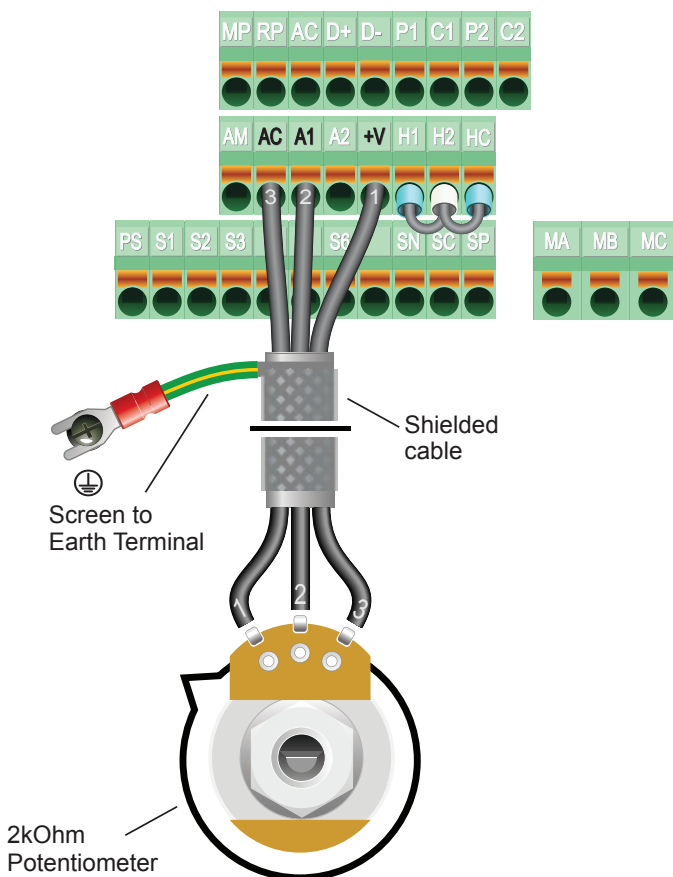

9.2 Connecting the Potentiometer

For the potentiometer to operate the GA500 must be in remote control mode. Use the LOC/REM key to toggle between local and remote control modes (the indicator is not illuminated when in remote).

A wiring diagram is shown in the illustration opposite. The most important connection at the Potentiometer end is the centre terminal or “wiper”. The wiper will output a variable voltage between 0 and 10 Volts and should be connected to the “A1” terminal on the Inverter. It is this voltage which provides the speed signal with 0V being slowest and 10V fastest.

If the rotation of the Potentiometer is the opposite to that required (ie. turn anti-clockwise to increase speed instead of clockwise) reverse connections AC and +V.

Use shielded twisted pair cable between Potentiometer and Inverter and ensure that the cable screen is connected to the Inverter earth terminal only.

In remote control without the start signal the speed reference can be seen on the display ranging from 0-50 with the values given.

10. How to connect and configure a Run Forward or Run Reverse switch

The procedure described in section 7 enables Run/Stop operation via the start and stop buttons on the Inverter keypad.

If this is unsuitable for the application, a remote switch can be used instead.

This section explains how to enable 2 wire control with Run Forward / Stop / Run Reverse commands via a single selector switch.

When set to operate in this way, the Run/Stop buttons on the keypad are not operational. When powered up with no parameter changes the GA500 is configured for this operation.

10.1 Parameters to check for remote Run/Stop

Parameter	Description	How to Set
PRr → b 1-02	Run Command	Default is 1 for terminal control; default is required for this example.
PRr → H 1-01	Digital Input S1 Function	Default is 40 for Run Forward; default is required for this example.
PRr → H 1-02	Digital Input S2 Function	Default is 41 for Run Reverse; default is required for this example.

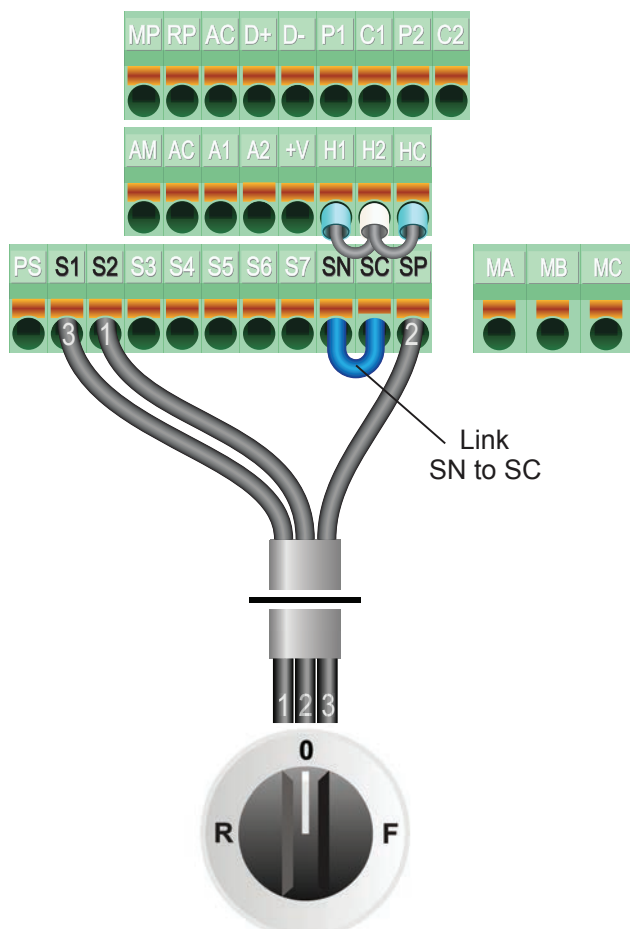

Switch, 3 Position
Normally Open
"Run Forward / Stop / Run Reverse"

10.2 Connecting the Switch

For the switch to operate the GA500 must be in remote control mode. Use the LOC/REM key to toggle between local and remote control modes (the indicator is not illuminated when in remote).

A wiring diagram is shown in the illustration opposite. A suitable 3 position NO (Normally Open) switch should be installed between terminals SP(24V), S1 and S2. The centre position should remain open circuit.

When a connection is made between terminals SP (24V) and S1, the motor will run forward. When terminals SP (24V) and S2 are connected, the motor will run in reverse.

If terminals S1 and S2 are connected to SP (24V) at the same time the motor will stop and an "external fault" will be triggered.

If the application only requires the motor to turn in one direction, a 2 position switch can be used and the connection to terminal S2 omitted.

11. How to connect and configure a Run/Stop switch with Forward/Reverse selection

The procedure described in section 7 enables Run/Stop operation via the start and stop buttons on the Inverter keypad.

If this is unsuitable for the application, remote switches can be used instead.

This section explains how to enable 2 wire control with Run/Stop and Forward/Reverse commands via separate selector switches. When set to operate in this way, the Run/Stop buttons on the keypad are not operational. To achieve this type of control, parameter changes are required.

11.1 Parameters to check for remote Run/Stop

Parameter	Description	How to Set
PR → b 1-02	Run Command	Default is 1 for terminal control; default is required for this example.
PR → H 1-01	Digital Input S1 Function	Default is 40 for Run Forward; change to 42 for Run/Stop operation.
PR → H 1-02	Digital Input S2 Function	Default is 41 for Run Reverse; change to 43 for Forward/Reverse selection.

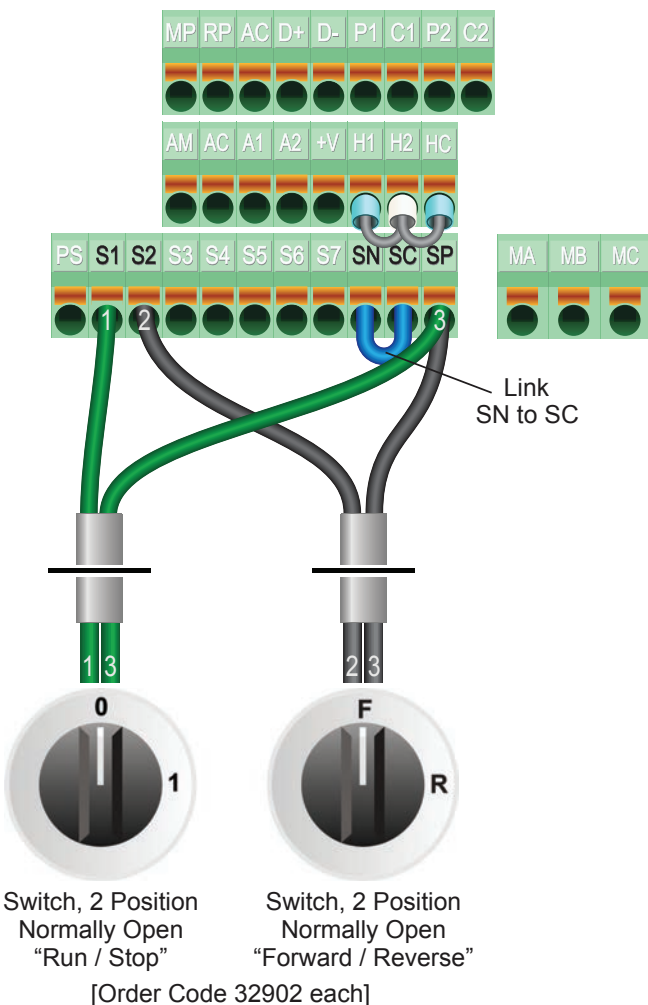

11.2 Connecting the Switch

For the switch to operate the GA500 must be in remote control mode. Use the LOC/REM key to toggle between local and remote control modes (the indicator is not illuminated when in remote).

A wiring diagram is shown in the illustration opposite. Two suitable 2 position NO (Normally Open) switches should be installed: One between terminals SP (24V) and S1 (Run / Stop) and the other between terminals SP (24V) and S2 (Forward / Reverse).

Note that the Forward/Reverse switch only selects the direction of rotation - it will not start or stop the motor. The direction can be set either before the motor is started or whilst it is running.

If the application only requires the motor to turn in one direction, the Forward/Reverse switch can be omitted.

12. How to configure “3 Wire” control with Run Forward Run Reverse and Stop pushbuttons

The procedure described in section 7 enables Run/Stop operation via the start and stop buttons on the Inverter keypad.

If this is unsuitable for the application, remote switches can be used instead.

This section explains how to enable 3 wire control with Start and Stop pushbuttons and direction selection switch.

When set to operate in this way, the Run/Stop buttons on the keypad are not operational.

12.1 Parameters to check for remote Run/Stop

Parameter	Description	How to Set
PR → R 1-03	Initialization	Default is 0; ensure all control cables are disconnected and change to 3330 for 3 wire control. <i>Note that this parameter changes several others automatically so it is the only change that needs to be made to enable 3-wire control to suit the diagram below. Once set return to F0.00 display.</i>

12.2 Connecting the Switches

For the switch to operate the GA500 must be in remote control mode. Use the LOC/REM key to toggle between local and remote control modes (the indicator is not illuminated when in remote).

A wiring diagram is shown in the illustration opposite. Two suitable pushbuttons and a 2 position switch should be installed:-

Stop: a normally closed pushbutton between terminals S2 and SP (24V).

Run: a normally open pushbutton between terminals S1 and S2.

Forward/Reverse: a normally open switch between terminals S5 and SP (24V).

A momentary connection between S1 and S2 will start the motor. It will continue to run until the connection between S2 and SP (24V) is broken. Direction can be reversed by closing the connection between S5 and SP (24V).

“Ready” indicator must be on for correct operation.

If the application only requires the motor to turn in one direction, the “Forward/Reverse” switch can be omitted.

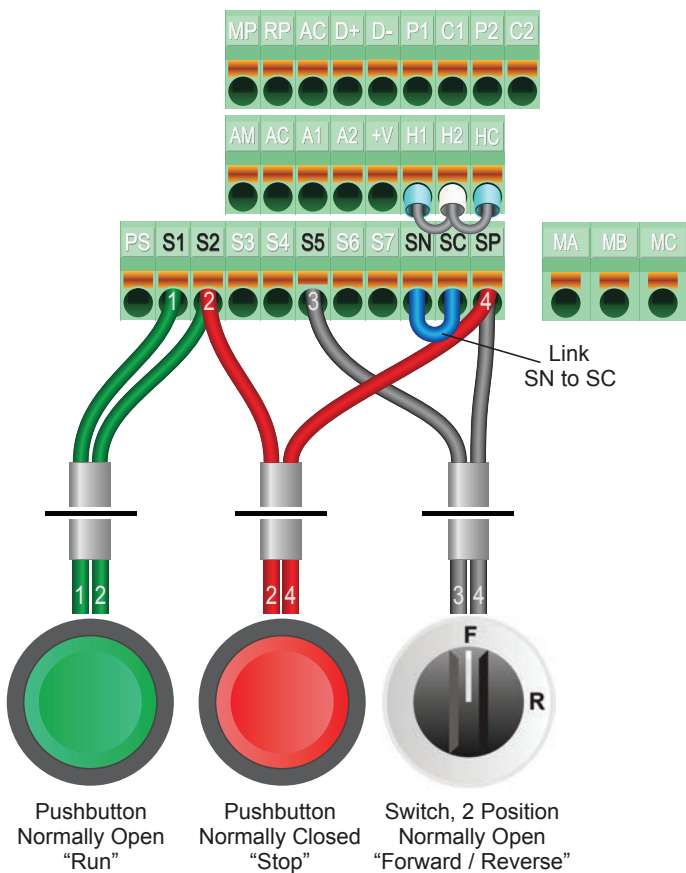

[Order Codes 32896, 32895 and 32902]

13. Brake Resistor Connection



Before commencing, confirm that the inverter and all cables are completely isolated from the power supply, have been isolated for at least 5 minutes and that the motor is not turning.

High inertia loads can cause overvoltage trips during deceleration and lead to “OU” error messages. In many cases, the solution is to increase the deceleration time to compensate.

However, if the application requires it, dynamic braking can be enabled to maintain or reduce deceleration times by absorbing the energy generated by such loads.

A Brake Resistor is first installed to absorb braking energy and dissipate it as heat. The resistor must be correctly sized for both the Inverter and application.

The “brake chopper” within the Inverter detects excessive braking energy and redirects it to the resistor when required.

13.1 Parameters to check for Dynamic Braking

Parameter	Description	How to Set
PRP → L3-04	Stall prevention during deceleration	Default is 1. Set to 0 to disable stall prevention. <i>Note: Stall prevention causes the GA500 to automatically increase the deceleration time to stop a load as quickly as possible if it is unable to stop it within the time specified. This is not desirable when dynamic braking will be used and is why it must be disabled.</i>

*The terminal arrangement for size 3 is shown. The terminals for other sizes are labelled using the same scheme (B1 and B2).

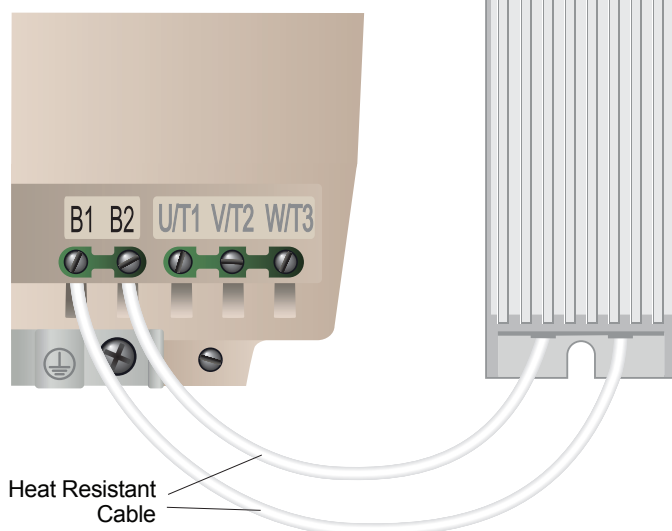

13.2 Connecting the Resistor

A wiring diagram is shown in the illustration opposite.

If a plastic tab is covering terminals B1 and B2, it can be removed.

Connect the brake resistor to the B1 and B2 terminals on the Inverter. The order of the connections is unimportant.

The braking resistor may get hot during operation. Ensure that it is suitably-rated and mounted to remain cool and prevent any heat generated from affecting other equipment. Some resistors may include a thermal relay for additional protection.

It is essential that a resistor of the correct rating is used. Consult the Inverter product listing at InverterDrive.com and manual issued by the manufacturer for details.

14. STO (Safe Torque Off) Connections



This section is an overview only. You must also refer to the manual provided by the manufacturer for full details of STO functionality

Safe Torque Off (STO) is a feature that is included on all GA500 products.

STO provides a facility to disable the output of the Inverter so that the motor it is controlling cannot be operated i.e. That no torque can be applied. However, it does not provide any form of braking so will not prevent the load from rotating the motor.

The STO function is only effective when wired to suitable safety devices that detect an 'unsafe' situation. A Safety assessment of the machinery is required by suitably qualified personnel to identify what should be considered unsafe and what safety devices are appropriate for the application.

It is not recommended to stop a motor using the Inverter STO function. The motor should be stopped before the STO feature is activated.

STO does not isolate the electrical supply. Therefore the Inverter must be isolated from the supply before any maintenance is carried out.

14.1 STO Links

The GA500 is supplied with links configured so that the Inverter can be used with the STO

disabled. The 'STO Disabled' illustration shows this arrangement. If the STO is to be used remove both links.

STO Disabled

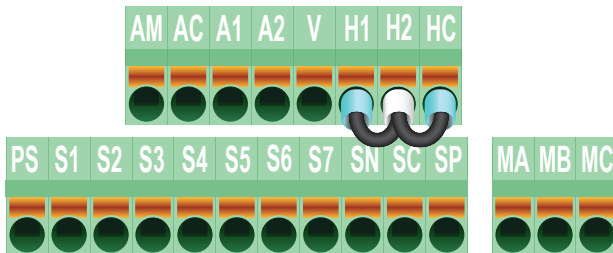

STO Enabled

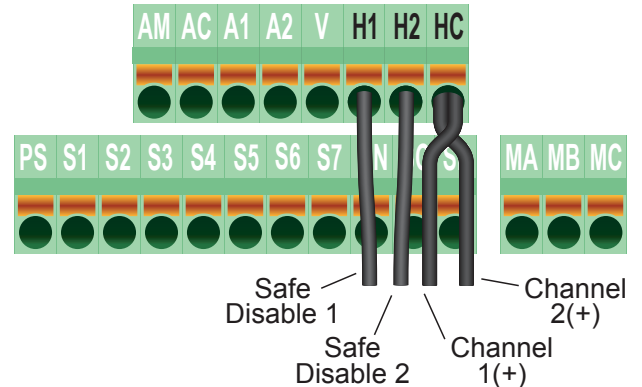

14.2 Keypad

When a dual channel Safety device is wired to the Inverter and both channels are closed (Safe) the Inverter can be operated as normal. If one or both of the channels open the Inverter will indicate an STO fault and cannot be operated.







15. How to reset the Inverter to Factory Defaults



14.1 Select parameter A1-03



From F 0.00 (or any F prefix), use the up and down arrow keys to select PAr then press the  key. A1-01 will be displayed.

Use the  and  keys to select each digit until 01 flashes to indicate that it is selected. Then, use the  and  keys to change the parameter to A1-03.

Press  to edit the parameter value.



14.2 Set parameter value to 2220

The display will show the default parameter value of 0000. Use the  key to cycle through each digit and the  and  keys to change the value to 2220 as shown. This will reset the Inverter for 2-wire control (as shown on pages 9, 10 and 11). For 3-wire control (as shown on page 12), change the value to 3330 instead.

Press  to save the changes.



14.3 Select parameter

When the process is complete, the display will show "End" and may briefly flash 0000 before returning to the parameter list (as shown in 14.1 above). Press ESC and ESC again to return to F0.00.

This process does not reset all parameters to factory defaults. The following parameters are not reset (this is not a comprehensive list, only the parameters referred to in this guide).

- A1-02; default is 0.
- C6-01; default is 0.
- E1-03; default is 0F.

To identify all changed parameters, use the Vrfy menu.