

YASKAWA AC Drive Option

EtherCAT Technical Manual

Model JOHB-SMP3

To correctly use the product, read this manual thoroughly and keep it for easy reference, inspection, and maintenance.
Make sure that the end user receives this manual.

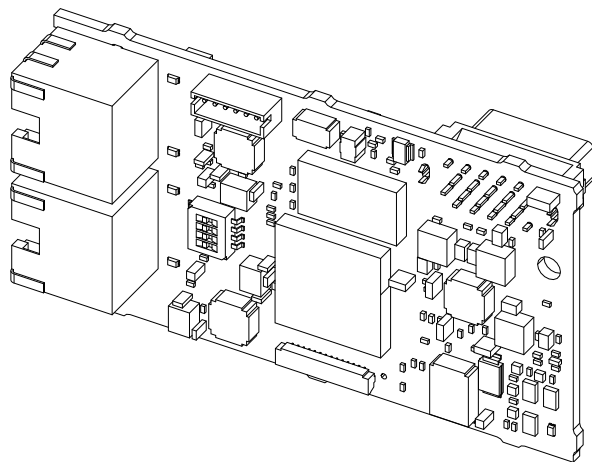

This Page Intentionally Blank

Table of Contents

1. Preface and Safety	7
Applicable Documentation	7
Glossary	7
Registered Trademarks	8
Supplemental Safety Information	8
Section Safety	8
2. Overview	8
Compatible Products	9
3. Receiving	9
Option Package Contents	10
Installation Tools	10
4. Option Components	11
Option PCB Components	11
Communication Modular Connector CN1 Port 1/Port 2	11
Option LED States	11
LEDs L/A OUT and L/A IN: Ethernet Link/Activity for Input and Output Ports	12
RUN LED	12
ERR LED	12
10/100	12
Meaning of LED Flash Rates	13
5. Installation Procedure	13
Section Safety	13
Settings for the DIP Switch S1	14
Procedures to Install and Wire Options on a Drive	14
Procedure A	15
Procedure B	16
Option Card Mounting Kit for GA500	18
Communication Cable Specifications	18
Option Connection Diagram	19
ESI File	19
6. Related Drive Parameters	19
7. Supported Modes of Operation	22
8. Object Dictionary	22
Object Dictionary Overview	22
Communication Profile Objects (DS 301)	22

Manufacturer Specific Profile Objects (DS 301)	23
Converter Specific Profile Objects	23
Drives and Motion Specific Profile Objects (DSP 402)	24
Communication Profile Objects (DS 301)	24
1000 (Hex.): Device Type	24
1001 (Hex.): Error Register	24
1003 (Hex.): Pre-defined Error Field	24
1008 (Hex.): Manufacturer Device Name	25
1009 (Hex.): Manufacturer Hardware Version	25
100A (Hex.): Manufacturer Software Version	25
1010 (Hex.): Store Parameters	25
1011 (Hex.): Restore Default Parameters	26
1018 (Hex.): Identity Object	26
1600 (Hex.), 1629 (Hex.), 1650 (Hex.): Receive PDO Mapping	27
1601 (Hex.) to 1628 (Hex.): Receive PDO Mapping	27
1A00 (Hex.), 1A29 (Hex.), 1A50 (Hex.): Transmit PDO Mapping	27
1A01 (Hex.) to 1A28 (Hex.): Transmit PDO Mapping	27
1C00 (Hex.): Sync Manager Communication Type	28
1C12 (Hex.): Sync Manager RxPDO Assign	28
1C13 (Hex.): Sync Manager TxPDO Assign	28
Manufacturer Specific Profile Objects (DS301) Details	28
2000 (Hex.): Operation Command	28
2010 (Hex.): Speed Reference/Speed Limit	29
2020 (Hex.): Torque Reference/Torque Limit	29
2030 (Hex.): Torque Compensation	30
2040 (Hex.): MEMOBUS/Modbus Read Request	30
2050 (Hex.): MEMOBUS/Modbus Write Request	30
2051 (Hex.): Advanced MEMOBUS/Modbus Write Response	31
2060 (Hex.): MEMOBUS/Modbus Unlimited ENTER Command	31
2061 (Hex.): MEMOBUS/Modbus Unlimited ENTER Command 2	32
2070 (Hex.): MEMOBUS/Modbus Limited ENTER Command	32
2071 (Hex.): MEMOBUS/Modbus Limited ENTER Command 2	32
2080 (Hex.) to 3100 (Hex.): Freely Configurable Input Objects	32
20D0 (Hex.): FM analog output 1	34
20E0 (Hex.): AM analog output 1	34
20F0 (Hex.): Multi-function DO Output	34
2100 (Hex.): Drive Status	35
2110 (Hex.): Output Frequency	35
2120 (Hex.): Output Current	36
2130 (Hex.): Output Torque Reference	36
2140 (Hex.): MEMOBUS/Modbus Read Response	36
2150 (Hex.): MEMOBUS/Modbus Write Response	37
2151 (Hex.): Advanced MEMOBUS/Modbus Write Response	37
2155 (Hex.): PDO Parameter Write Response	37
2160 (Hex.): MEMOBUS/Modbus Unlimited Enter Command Response	37
2180 (Hex.) to 21F0 (Hex.): Freely Configurable Output Objects	38
2200 (Hex.): Motor Speed	38
2210 (Hex.): DC-Bus Voltage/Control Circuit Voltage (For U1000)	39
2220 (Hex.): Analog Input Monitor A1	39
2240 (Hex.): Analog Input Monitor A2	39
2260 (Hex.): Analog Input Monitor A3	39
2270 (Hex.): Drive DI Input	39
2301 (Hex.): Error Register	40
2318 (Hex.): Drive Information	40
251x (Hex.): Main Parameter Group A	40
252x (Hex.): Main Parameter Group B	41
253x (Hex.): Main Parameter Group C	41
254x (Hex.): Main Parameter Group D	42
255x (Hex.): Main Parameter Group E	42
256x (Hex.): Main Parameter Group F	42

258x (Hex.): Main Parameter Group H	43
25Cx (Hex.): Main Parameter Group L	43
25Ex (Hex.): Main Parameter Group N	43
25Fx (Hex.): Main Parameter Group O	44
261x (Hex.): Main Parameter Group Q	44
262x (Hex.): Main Parameter Group R	45
264x (Hex.): Main Parameter Group T	45
265x (Hex.): Main Parameter Group U	45
2E00 (Hex.): Gateway Mode Communication Settings	46
2E01 (Hex.) to 2E04 (Hex.): Gateway Slave Drive Operation	46
2EFF (Hex.): Gateway MEMOBUS/Modbus Read/Write Request	47
2F01 (Hex.) to 2F04 (Hex.): Gateway Slave Drive Status	47
2FFF (Hex.): Gateway MEMOBUS/Modbus Read/Write Response	47
4001 (Hex.): Option Info + Status Record	48
4010 (Hex.): Store Parameters	48
4011 (Hex.): Restore Default Parameters	49
Converter Specific Profile Objects	49
5000 (Hex.): Regenerated Energy	49
5001 (Hex.): Input Voltage	49
5002 (Hex.): Current Limit	50
5003 (Hex.): AC Power	50
5004 (Hex.): Consumed Energy	50
5005 (Hex.): DC Bus Voltage Reference	50
CANopen DSP402 Controlword/Statusword	51
CANopen DSP402 Controlword	51
CANopen DSP402 Statusword	51
Controlword Operation Mode Specific Bits in Velocity Mode	52
Statusword Operation Mode Specific Bits in Velocity Mode	52
Controlword State Transition Bits	52
Statusword State Transition Bits	52
CANopen DSP402 State Transition Definition	53
CANopen DSP402 State Diagram	53
CANopen DSP402 Event Description	53
Drives and Motion Profile Objects (DSP 402) Details	54
6040 (Hex.): Controlword	54
6041 (Hex.): Statusword	54
6042 (Hex.): vl Target Velocity	55
6043 (Hex.): vl Velocity Demand	55
6044 (Hex.): vl Velocity Control Effort/Actual Value	55
6046 (Hex.): vl Velocity Min Max Amount	55
6048 (Hex.): vl Velocity Acceleration	56
6049 (Hex.): vl Velocity Deceleration	56
604A (Hex.): vl Velocity Quick Stop	56
604C (Hex.): vl Dimension Factor	56
604D (Hex.): vl Pole Number	57
6060 (Hex.): Modes of Operation	57
6061 (Hex.): Modes of Operation Display	57
60FD (Hex.): Digital Inputs	58
60FE (Hex.): Digital Outputs	58
6502 (Hex.): Supported Drive Modes	59
9. Process Data Objects (PDO)	59
Process Data Objects (PDO)	59
Transmit PDOs (TxPDO)	59
Receive PDOs (RxPDO)	60
RxPDO Mapped Drive Registers Above 0100 (Hex.) Range	60
10. Examples	61

Example Project with SPEED7	61
Example Project with TwinCAT System Manager	64
Example to Select MEMOBUS/Modbus Register into Freely Configurable Objects.	66
11. Troubleshooting	68
EtherCAT Option Card Error Codes	68
Emergency Error Codes	68
SDO Abort Codes	73
Drive-Side Error Codes	73
Fault	73
Minor Faults and Alarms	74
bUS Fault Tolerance	74
Option Board Error Management	75
Option Error Codes	75
Option Fault Monitors <i>U6-98</i> and <i>U6-99</i>	75
Self RAM Check	76
12. European Standards	76
EMC Directive Compliance	77
Option Installation	77
13. Specifications	78
Specifications	78
14. Disposal	78
Disposal Instructions	78
WEEE Directive	78
Revision History	79

1 Preface and Safety

YASKAWA Electric supplies component parts for use in a wide variety of industrial applications. The selection and application of YASKAWA products remain the responsibility of the equipment designer or end user.

YASKAWA accepts no responsibility for the way its products are incorporated into the final system design. Under no circumstances should any YASKAWA product be incorporated into any product or design as the exclusive or sole safety control. Without exception, all controls should be designed to detect faults dynamically and fail safely under all circumstances. All products designed to incorporate a component part manufactured by YASKAWA must be supplied to the end user with appropriate warnings and instructions as to the safe use and operation of that part. Any warnings provided by YASKAWA must be promptly provided to the end user. YASKAWA offers an express warranty only as to the quality of its products in conforming to standards and specifications published in the manual. **NO OTHER WARRANTY, EXPRESS OR IMPLIED, IS OFFERED.** YASKAWA assumes no liability for any personal injury, property damage, losses, or claims arising from misapplication of its products.

◆ Applicable Documentation

Document	Description
JOHB-SMP3 Multi-Protocol EtherNet Quick Setup Procedure Manual No.: TOBP C730600 0H	Read this manual first. The manual provides information about wiring, settings, functions, and troubleshooting. The manual is packaged together with the product.
YASKAWA AC Drive Option EtherCAT Technical Manual Manual No.: SIEP C730600 0L (This book)	The technical manual contains detailed information about the option. Access the following sites to obtain the technical manual: U.S.: http://www.yaskawa.com Europe: http://www.yaskawa.eu.com Japan: http://www.e-mechatronics.com Other areas: Check the back cover of these manuals. For questions, contact Yaskawa or a Yaskawa representative.
YASKAWA AC Drive Manuals	Refer to the drive manual to connect with the option. Drive manuals contain basic installation and wiring information in addition to detailed parameter setting, fault diagnostic, and maintenance information. The manuals also include important information about parameter settings and tuning the drive. The Quick Start Guides are packaged with the drive. The most recent versions of these manuals are available for download on our documentation websites: U.S.: http://www.yaskawa.com Europe: http://www.yaskawa.eu.com Japan: http://www.e-mechatronics.com Other areas: Check the back cover of these manuals. For questions, contact Yaskawa or a Yaskawa representative.

◆ Glossary

Terms	Definition
Option	YASKAWA AC Drive Option JOHB-SMP3 with DIP Switches Set for EtherCAT
Keypad	<ul style="list-style-type: none"> • HOA Operator • LCD Operator • LED Operator • HOA Keypad • LCD Keypad • LED Keypad
EtherCAT	Ethernet for Control Automation Technology, an open Ethernet-based network
Online-DRV	NOID processing mode, process (ctrl/resp) data is active
Online-DRVMB	NOID processing mode, process resp data is active, ctrl data is on hold (Until MEMOBUS process is complete)
Online-PRG	NOID processing mode, NO process (ctrl/resp) data is active
LED	Light Emitting Diode
OPT	The unit described in this document
INV	Inverter drive
PCB	Printed Circuit Board
FCS	Frame Check Sequence
INVR	MEMOBUS register number

Terms	Definition
ESI	EtherCAT Slave Information file
Hex. (Example: 900 (Hex.))	Identifies a unit for hexadecimal number format.

◆ Registered Trademarks

- EtherCAT is a registered trademark of Beckhoff Automation GmbH.
- Trademarks are the property of their respective owners.

◆ Supplemental Safety Information

Read and understand this manual before installing, operating, or servicing this option. The option must be installed according to this manual and local codes.

The following conventions are used to indicate safety messages in this manual. Failure to heed these messages could result in serious or possibly even fatal injury or damage to the products or to related equipment and systems.

⚠ DANGER This signal word identifies a hazard that will cause serious injury or death if you do not prevent it.

⚠ WARNING This signal word identifies a hazard that can cause death or serious injuries if you do not prevent it.

⚠ CAUTION This signal word identifies a hazardous situation, which, if not avoided, can cause minor or moderate injury.

NOTICE This signal word identifies a property damage message that is not related to personal injury.

■ Section Safety

General Precautions

- The diagrams in this section may include options and drives without covers or safety shields to illustrate details. Be sure to reinstall covers or shields before operating any devices. The option should be used according to the instructions described in this manual.
- The diagrams in this manual are provided as examples only and may not pertain to all products covered by this manual.
- The products and specifications described in this manual or the content and presentation of the manual may be changed without notice to improve the product and/or the manual.
- Contact Yaskawa or a Yaskawa representative and provide the manual number shown on the front cover to order new copies of the manual.

⚠ DANGER Do not ignore the safety messages in this manual. If you ignore the safety messages in this manual, it will cause serious injury or death. The manufacturer is not responsible for injuries or damage to equipment.

⚠ WARNING *Electrical Shock Hazard.* Do not modify the drive or option circuitry. Failure to obey can cause serious injury or death, or cause damage to the drive or option and will void warranty. Yaskawa is not responsible for modifications of the product made by the user.

NOTICE *Damage to Equipment.* Do not use steam or other disinfectants to fumigate wood for packaging the drive. Use alternative methods, for example heat treatment, before you package the components. Gas from wood packaging fumigated with halogen disinfectants, for example fluorine, chlorine, bromine, iodine or DOP gas (phthalic acid ester), can cause damage to the drive.

2 Overview

This option is designed to contact YASKAWA AC drives or converters to an EtherCAT network.

Using this option and an EtherCAT master you can:

- Operate the drive or converter
- Monitor the drive or converter operation status
- Change drive or converter parameter settings

The option contains support for the Velocity mode according the CANopen Device Profile and Motion Control (DSP 402) profile. It also contains YASKAWA vendor-specific CANopen objects based on the present CANopen option specification.

The EtherCAT Option supports the following communication profiles:

- DS 301 Ver.4.02
- DSP 402 Ver.3.0 Velocity Mode (This object is not available for D1000 and R1000.)



◆ Compatible Products

You can use the option with these products:

Table 2.1 Compatible Products

Product Series	Model(s)	Software Version ^{*1}
A1000	CIMR-Ax2Axxxx	≥ 1017
	CIMR-Ax4A0002 - 4A0675	
	CIMR-Ax4A0930, 4A1200	≥ 3015
	CIMR-Ax5Axxxx	≥ 5045 ≥ 1017
D1000	CIMR-Dx2A0005 - 4A0370	≥ 2006
	CIMR-Dx4A0630	≥ 3014
R1000	CIMR-Rx2A03P5 - 4A0300	≥ 2102
U1000	CIMR-UxxAxxxx	≥ 1010
	CIMR-UxxExxxx	
	CIMR-UxxPxxxx	
	CIMR-UxxWxxxx	
CR700	CIPR-CR70xxxxx	≥ 1012
GA500	CIPR-GA50xxxxx	≥ 1010
GA700	CIPR-GA70xxxxx	≥ 1010
GA800	CIPR-GA80xxxxx	≥ 9010

*1 Refer to "PRG" on the drive nameplate for the software version number.

Note:

- Refer to the option package labeling in the field designated "PRG (four digit number)" to identify the option software version.

- For Yaskawa customers in the North or South America regions:

If your product is not listed in [Table 2.1](#), refer to the web page below to confirm this manual is correct for your product. The web page provides a list of option manuals by product, and a direct link to download a PDF of the manual.

Scan QR code or refer to:

<http://www.yaskawa.com/optionlookup>



3 Receiving

After you receive the option package:

- Make sure that there is no damage to the option and no parts are missing. The Yaskawa warranty does not include damage from shipping. If there is damage to the option or other parts, contact the shipping company immediately.

NOTICE

Damage to Equipment. Do not use damaged parts to connect the drive and the option. Failure to comply could damage the drive and option.

- Contact the distributor where you purchased the option or contact Yaskawa or a Yaskawa representative about any problems with the option.

◆ Option Package Contents

Table 3.1 Contents of Package

Option Contents		Quantity
Option		1
Ground Wire ^{*1}		1
Screws (M3)		3 ^{*2}
LED Labels ^{*3}	1000-Series	1
	GA500, GA700, GA800, CR700	1
Quick Setup Procedure		1

*1 GA500, GA700, GA800, and CR700 drives do not use the ground wire.

*2 GA700, GA800, and CR700 drives use two screws only.

*3 LED labels are located on this label sheet.

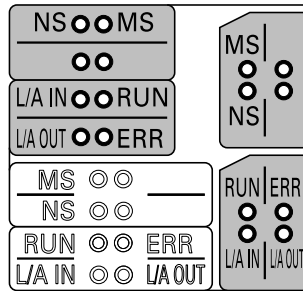

Figure 3.1 LED Label Sheet

◆ Installation Tools

You can use these tools to install the option to the drive:

- A Phillips screwdriver or slotted screwdriver ^{*1}.
- Non-conductive tweezers or a tool with a tip width of approximately 0.5 mm (0.02 in) to set DIP switch S1.
- A pair of diagonal cutting pliers.
- A small file or medium-grit sandpaper.

*1 Phillips screw sizes are different for different drive capacities. Prepare different screwdrivers for different screw sizes.

4 Option Components

◆ Option PCB Components

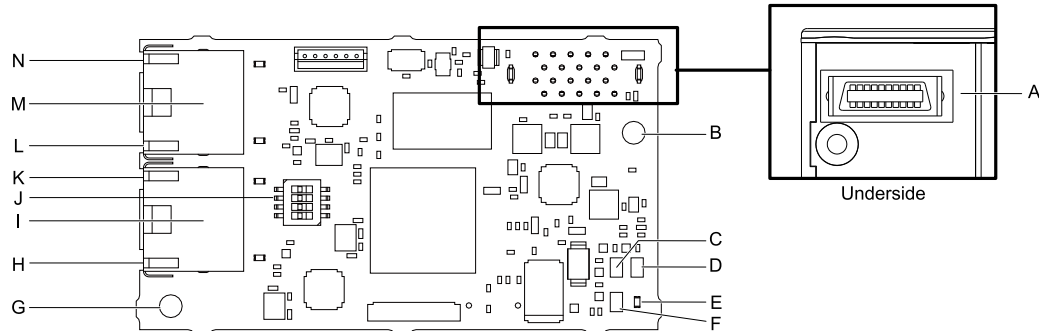

- | | |
|--|--|
| A - Connector (CN5) | H - Port 2 LED (10/100) *1 |
| B - Installation hole | I - Option modular connector CN1B (Port 2) (RJ45) |
| C - LED (L/A IN) *1 | J - DIP switch S1 |
| D - LED (RUN) *1 | K - Port 2 LED (LINK/ACT) *1 |
| E - LED (ERR) | L - Port 1 LED (10/100) *1 |
| F - LED (L/A OUT) | M - Option modular connector CN1A (Port 1) (RJ45) |
| G - Ground terminal (FE) and installation hole *2 | N - Port 1 LED (LINK/ACT) *1 |

Figure 4.1 Option PCB Components

*1 Refer to [Option LED States on page 11](#) for more information about the LEDs.

*2 Connect the included ground wire during installation. The ground wire is not necessary for installation on GA700, GA800, and CR700 drives. For GA500 drives, connect the included ground wire to the separately-sold communication option case (model: JOHB-GA50).

◆ Communication Modular Connector CN1 Port 1/Port 2

Option connections CN1A (Port 1) and CN1B (Port 2) are connection points for customer-supplied EtherCAT network communication cables. These ports accept customer-supplied male 8-way Ethernet modular RJ45 connectors.

Table 4.1 Male 8-way Ethernet Modular Connector (Customer-Supplied)

Male 8-way Ethernet Modular Connector	Pin	Description
	1 (Pair 2)	Transmit data (TXD) +
	2 (Pair 2)	Transmit data (TXD) -
	3 (Pair 3)	Receive data (RXD) +
	4 (Pair 1)	Not used
	5 (Pair 1)	Not used
	6 (Pair 3)	Receive data (RXD) -
	7 (Pair 4)	Not used
	8 (Pair 4)	Not used

◆ Option LED States

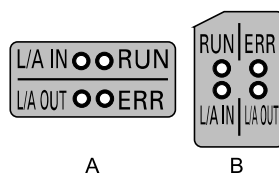

A - 1000-Series

B - GA500, GA700, GA800, CR700

Figure 4.2 Option LED Labels

■ LEDs L/A OUT and L/A IN: Ethernet Link/Activity for Input and Output Ports

The Link/Activity indicators show the status of the physical link and show activity on the link period.

LED	Color	Display	Meaning
Link Activity IN (L/A IN) Link Activity OUT (L/A OUT)	-	OFF	No link. The communication cable is not physically connected. The communication controller is not started up.
	Green	ON	The module is connected to Ethernet. A communication cable is physically connected, but there is no data exchange.
	Green	Flickering	There is traffic on Ethernet, data is being exchanged.

■ RUN LED

A green lit RUN LED indicates the status of the communication network state machine.

A red lit RUN LED is only used when updating the option firmware.

LED	Color	Display	Meaning
RUN	-	OFF	The device is in Init state.
	Green	Blinking	The device is in Pre-Operational State.
	Green	Single Flash	The device is in Safe-Operational State.
	Green	ON	The device is in Operational State.
	Red	Blinking (1 Hz or 6 Hz)	The firmware upgrade process for the option is in progress. 1 Hz: Firmware loader in IDLE state (waiting for commands from the drive) 6 Hz: Firmware loader is processing commands

■ ERR LED

The red error LED indicates the presence of any errors.

LED	Color	Display	Meaning
ERR	-	OFF	No link. The communication option is in working condition.
	Red	Blinking	General configuration error.
		Single Flash	The slave device application changed the communication state autonomously: The parameter "Change" in the AL status register is set to 01 (Hex.); change/error.
		Double Flash	There was a sync manager watchdog time out.
		ON	Possible causes: 1. There was a Process Data Interface error, the NOID application interface failed. 2. An option FATAL event occurred.
		Blinking (1 Hz)	An option EEPROM error occurred.

■ 10/100

The 10/100 LED indicates the status of the physical link.

LED	Color	Display	Meaning
10/100	-	OFF	Link is not established.
	Green	ON	Link is established.

■ Meaning of LED Flash Rates

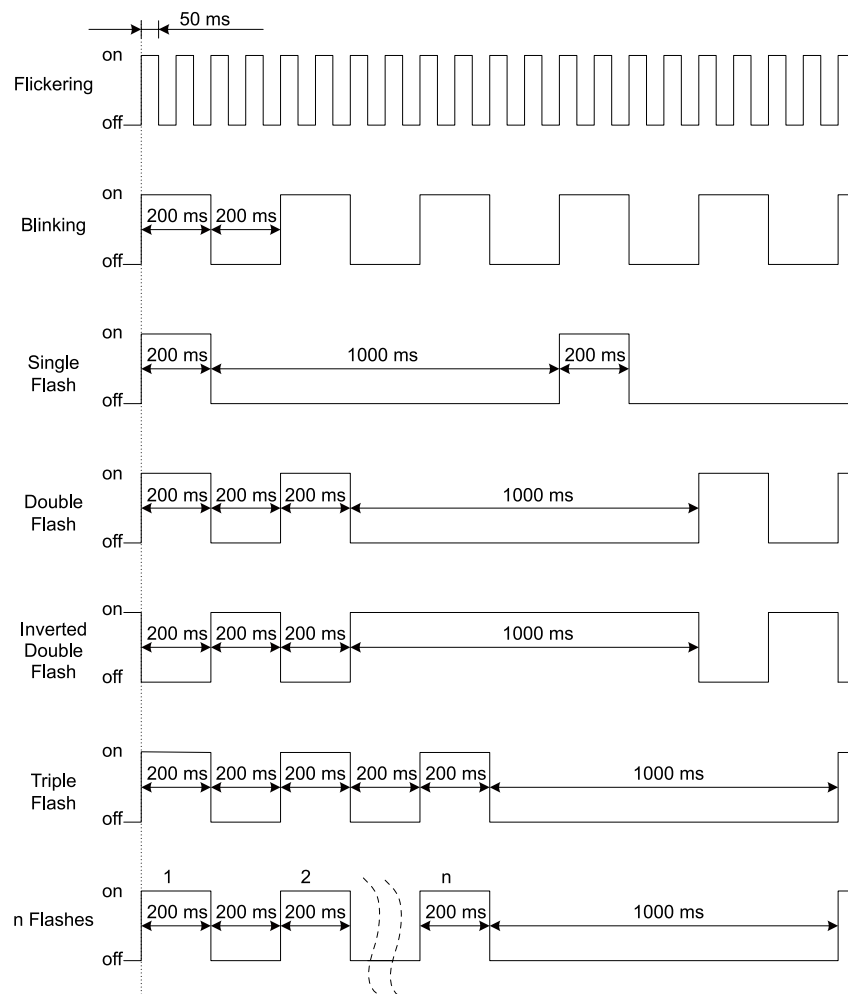

Figure 4.3 Meaning of LED Flash Rates

5 Installation Procedure

◆ Section Safety

⚠ DANGER *Electrical Shock Hazard. Do not examine, connect, or disconnect wiring on an energized drive. Before servicing, disconnect all power to the equipment and wait for the time specified on the warning label at a minimum. The internal capacitor stays charged after the drive is de-energized. The charge indicator LED extinguishes when the DC bus voltage decreases below 50 Vdc. When all indicators are OFF, measure for dangerous voltages to make sure that the drive is safe. If you do work on the drive when it is energized, it will cause serious injury or death from electrical shock.*

⚠ WARNING *Electrical Shock Hazard. Do not operate the drive when covers are missing. Replace covers and shields before you operate the drive. Use the drive only as specified by the instructions. Some figures in this section include drives without covers or safety shields to more clearly show the inside of the drive. If covers or safety shields are missing from the drive, it can cause serious injury or death.*

⚠ WARNING *Electrical Shock Hazard. Only let approved personnel install, wire, maintain, examine, replace parts, and repair the drive. If personnel are not approved, it can cause serious injury or death.*

⚠ WARNING *Electrical Shock Hazard. Do not remove covers or touch circuit boards while the drive is energized. If you touch the internal components of an energized drive, it can cause serious injury or death.*

⚠ WARNING *Electrical Shock Hazard. Do not use damaged wires, put too much force on the wiring, or cause damage to the wire insulation. Damaged wires can cause serious injury or death.*

⚠ WARNING *Fire Hazard. Tighten all terminal screws to the correct tightening torque. Connections that are too loose or too tight can cause incorrect operation and damage to the drive. Incorrect connections can also cause death or serious injury from fire.*

NOTICE *Damage to Equipment. When you touch the option, make sure that you observe correct electrostatic discharge (ESD) procedures. If you do not follow procedures, it can cause ESD damage to the drive circuitry.*

NOTICE *Damage to Equipment. Do not de-energize the drive while the drive is outputting voltage. Incorrect equipment sequencing can cause damage to the drive.*

NOTICE *Do not operate a drive or connected equipment that has damaged or missing parts. You can cause damage to the drive and connected equipment.*

NOTICE *Use Yaskawa connection cables or recommended cables only. Incorrect cables can cause the drive or option to function incorrectly.*

NOTICE *Damage to Equipment. Correctly connect the connectors. Incorrect connections can cause malfunction or damage to the equipment.*

NOTICE *Damage to Equipment. Make sure that all connections are correct after you install the drive and connecting peripheral devices. Incorrect connections can cause damage to the option.*

◆ Settings for the DIP Switch S1

Use the DIP switch S1 on the option to select the communication protocol.

⚠ WARNING *Electrical Shock Hazard. Make sure that the drive power supply was de-energized, then set DIP switch S1. Failure to obey will cause death or serious injury.*

Use non-conductive tweezers or a tool with a tip width of approximately 0.5 mm (0.02 in) to set DIP switch S1.

Figure 5.1 shows the default settings for the DIP switch S1.

As the communication protocol is not selected, when the drive is energized during the default setting, it causes oFA00 [Option Not Compatible with Port] or PSE [JOHB-SMP3 Protocol Set Error].

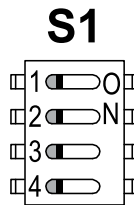

Figure 5.1 Default Settings for DIP Switch S1

When you use EtherCAT, set the DIP switch S1 as shown in Figure 5.2.

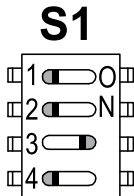

Figure 5.2 Settings for the DIP Switch S1

◆ Procedures to Install and Wire Options on a Drive

Procedures to install and wire the option are different for different drive models.

Refer to Table 5.1 to check the procedures to install and wire the option on a drive.

Table 5.1 Procedures to Install and Wire Options on a Drive

Drive	Procedures to Install and Wire Options on a Drive	Page
A1000	Procedure A	15
D1000	Procedure A	15
R1000	Procedure A	15
U1000	Procedure A	15
GA500	*1	-
GA700	Procedure B	16
GA800	Procedure B	16
CR700	Procedure B	16

*1 To install the option on GA500 drives, use the option mounting kit (JOHB-GA50) and manual.

■ Procedure A

This section shows the procedure to install and wire the option on a 1000-series drive.

Prepare the Drive for the Option

Correctly wire the drive as specified by the manual packaged with the drive. Make sure that the drive functions correctly. Refer to the drive manuals for more information.

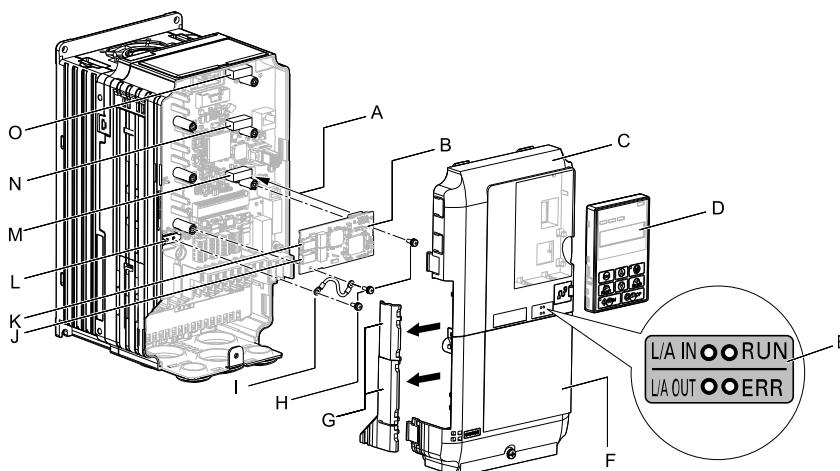

- | | |
|--|---|
| A - Insertion point for CN5 connector | I - Ground wire |
| B - Option | J - Option modular connector CN1B (Port 2) (RJ45) |
| C - Drive front cover | K - Option modular connector CN1A (Port 1) (RJ45) |
| D - Keypad | L - Drive grounding terminal (FE) |
| E - LED label | M - Connector CN5-A |
| F - Drive terminal cover | N - Connector CN5-B (Not available for communication option installation.) |
| G - Removable tabs for wire routing | O - Connector CN5-C (Not available for communication option installation.) |
| H - Included screws | |

Figure 5.3 Drive Components with Option

Install the Option

⚠ DANGER *Electrical Shock Hazard. Do not examine, connect, or disconnect wiring on an energized drive. Before servicing, disconnect all power to the equipment and wait for the time specified on the warning label at a minimum. The internal capacitor stays charged after the drive is de-energized. The charge indicator LED extinguishes when the DC bus voltage decreases below 50 Vdc. When all indicators are OFF, measure for dangerous voltages to make sure that the drive is safe. If you do work on the drive when it is energized, it will cause serious injury or death from electrical shock.*

NOTICE *Damage to Equipment. When you touch the option, make sure that you observe correct electrostatic discharge (ESD) procedures. If you do not follow procedures, it can cause ESD damage to the drive circuitry.*

Note:

You can only install this option into the CN5-A connector on the drive control board.

1. Shut off power to the drive and wait for the time specified on the drive warning label at a minimum. Make sure that the charge indicator LED is unlit. Refer to the drive manuals for more information.
2. Remove the keypad (D), front cover (C), and terminal cover (F).
3. Put the LED label (E) in the correct position on the drive front cover (C).
4. Install the option (B) into the CN5-A connector (M) on the drive and use the included screws (H) to put it in place.
5. Use one of the remaining included screws (H) to connect one end of the ground wire (I) to the ground terminal (L). Use the last remaining included screw (H) to connect the other end of the ground wire (I) to the remaining ground terminal and installation hole on the option (B).
Tighten the screws to a correct tightening torque:
 - 0.5 N·m to 0.6 N·m (4.4 lbf·in to 5.3 lbf·in)

Note:

The drive has only two ground terminal screw holes. When you connect three options, two options will share one ground terminal.

6. Route the option wiring.
Procedures to wire the option are different for different drive models.

- You can route the option wiring through openings on the front cover of some models. Remove the perforated tabs on the left side of the front cover as shown in [Figure 5.4-A](#) to create the necessary openings on these models. To prevent damage to the cable from the cut end, treat the cut surface with sandpaper.
 - Route the option wiring inside the enclosure as shown in [Figure 5.4-B](#).
- Refer to the drive manuals for more information.

Note:

Isolate communication cables from main circuit wiring and other electrical and power lines.

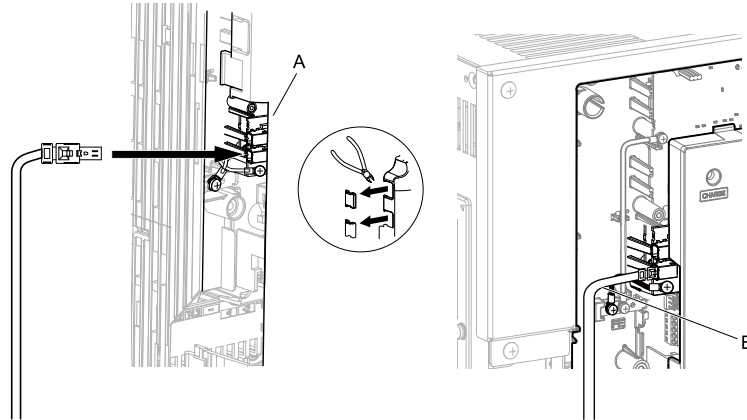

A - Route wires through the openings provided on the left side of the front cover. ^{*1}

B - Use the open space provided inside the drive to route option wiring.

Figure 5.4 Wire Routing Examples

^{*1} If there is wiring outside the enclosure, the drive will not meet Enclosed wall-mounted type (IP20/UL Type 1) requirements.

- Firmly connect the Ethernet communication cables to CN1B (Port 2) (J), and/or CN1A (Port 1) (K). Isolate communication cables from main circuit wiring and other electrical and power lines. Make sure that you firmly connect the cable end. Refer to [Communication Cable Specifications on page 18](#) for more information.
 - Reattach the front cover (C), terminal cover (F), and keypad (D). Refer to the drive manuals for more information.
- NOTICE** Do not pinch cables between the front covers and the drive. Failure to comply could cause erroneous operation.
- Set drive parameters in [Related Drive Parameters on page 19](#) for correct option performance.

■ Procedure B

This section shows the procedure to install and wire the option on a GA700, GA800, or CR700 drive.

Prepare the Drive for the Option

Correctly wire the drive as specified by the manual packaged with the drive. Make sure that the drive functions correctly. Refer to the drive manuals for more information.

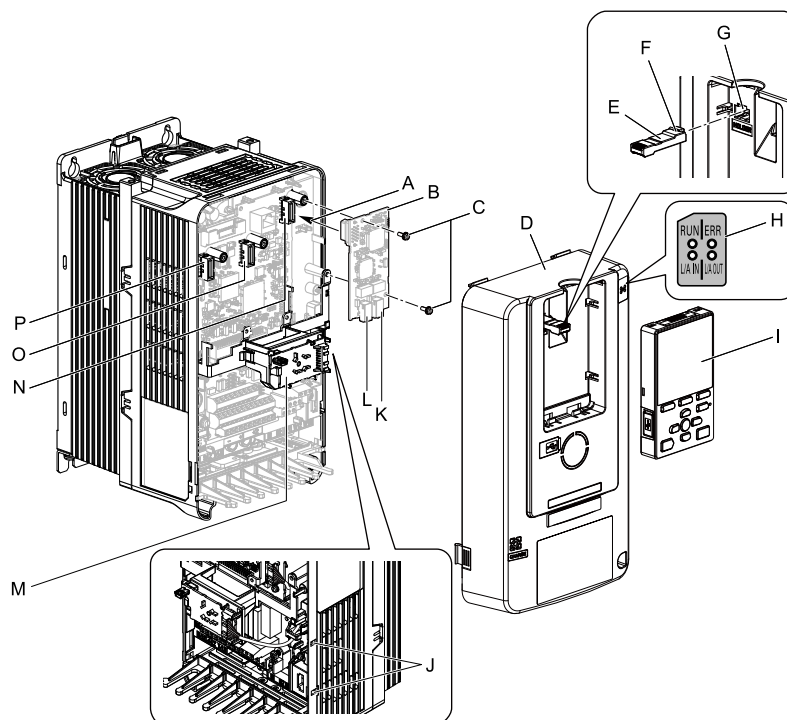

- | | |
|--|---|
| A - Insertion point for CN5 connector | I - Keypad |
| B - Option | J - LED Status Ring board temporary placement holes |
| C - Included screws | K - Option modular connector CN1B (Port 2) (RJ45) |
| D - Drive front cover | L - Option modular connector CN1A (Port 1) (RJ45) |
| E - Keypad connector | M - LED Status Ring board |
| F - Keypad connector tab | N - Connector CN5-A |
| G - Holder | O - Connector CN5-B (Not available for communication option installation.) |
| H - LED label | P - Connector CN5-C (Not available for communication option installation.) |

Figure 5.5 Drive Components with Option

Install the Option

⚠ DANGER *Electrical Shock Hazard. Do not examine, connect, or disconnect wiring on an energized drive. Before servicing, disconnect all power to the equipment and wait for the time specified on the warning label at a minimum. The internal capacitor stays charged after the drive is de-energized. The charge indicator LED extinguishes when the DC bus voltage decreases below 50 Vdc. When all indicators are OFF, measure for dangerous voltages to make sure that the drive is safe. If you do work on the drive when it is energized, it will cause serious injury or death from electrical shock.*

NOTICE *Damage to Equipment. When you touch the option, make sure that you observe correct electrostatic discharge (ESD) procedures. If you do not follow procedures, it can cause ESD damage to the drive circuitry.*

Note:

You can only install this option into the CN5-A connector on the drive control board.

- Put the LED label (H) in the correct position on the drive front cover (D).
- Shut off power to the drive and wait for the time specified on the drive warning label at a minimum. Make sure that the charge indicator LED is unlit, then remove the keypad and front cover. Refer to the drive manuals for more information.
- Remove the keypad (I), then move the keypad connector (E) to the holder (G) on the drive, then remove the front cover.
- Carefully remove the LED Status Ring board (M) and put it in the temporary placement holes (J) on the right side of the drive. Refer to the drive manuals for more information.

NOTICE *Do not remove the LED Status Ring board cable connector. If you disconnect the LED Status Ring board, it can cause incorrect operation and damage to the drive.*

5. Install the option (B) into the CN5-A connector (N) on the drive and use the included screws (C) to put it in place.

Tighten the screws to a correct tightening torque:

- 0.5 N·m to 0.6 N·m (4.4 lbf-in to 5.3 lbf-in)

Note:

1. A ground wire is not necessary. Do not use the ground wire.
2. Only two screws are necessary to install the option on GA700, GA800, and CR700 drives.

6. Firmly connect the Ethernet communication cables to CN1B (Port 2) (K), and/or CN1A (Port 1) (L).

Isolate communication cables from main circuit wiring and other electrical and power lines. Make sure that you firmly connect the cable end. Refer to [Communication Cable Specifications on page 18](#) for more information.

Note:

Maximum transmission distance is 100 m (328 ft). Minimum wiring distance between stations is 0.2 m (7.9 in).

7. Install the LED status ring board (M), front cover (D), and the keypad to their initial positions, then install the keypad (I).

Put the keypad connector tab (F) into the holder when you install the keypad connector to the holder.

Refer to the drive manuals for more information.

NOTICE Do not pinch cables between the front cover or the LED Status Ring board and the drive. Failure to comply could cause erroneous operation.

8. Set drive parameters in [Related Drive Parameters on page 19](#) for correct option performance.

◆ Option Card Mounting Kit for GA500

An option card mounting kit is necessary to install the option on a GA500 drive. The option card mounting kit model is: JOHB-GA50. This kit is sold separately.

Refer to the option card mounting kit manual for more information about installation.

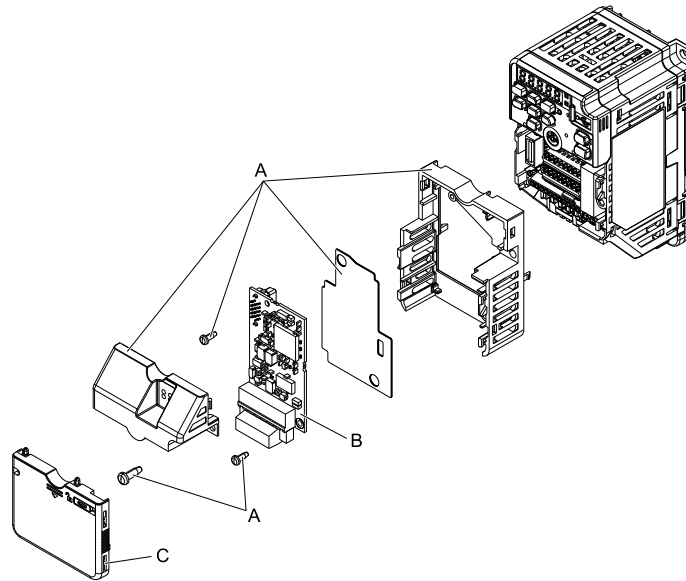

A - Option card mounting kit components (sold separately)

C - Drive front cover

B - Option

Figure 5.6 Option Card Mounting Kit (JOHB-GA50)

◆ Communication Cable Specifications

Yaskawa recommends using EtherCAT dedicated Cat5e or better communication cables. The Yaskawa warranty does not cover other cable types.

■ Option Connection Diagram

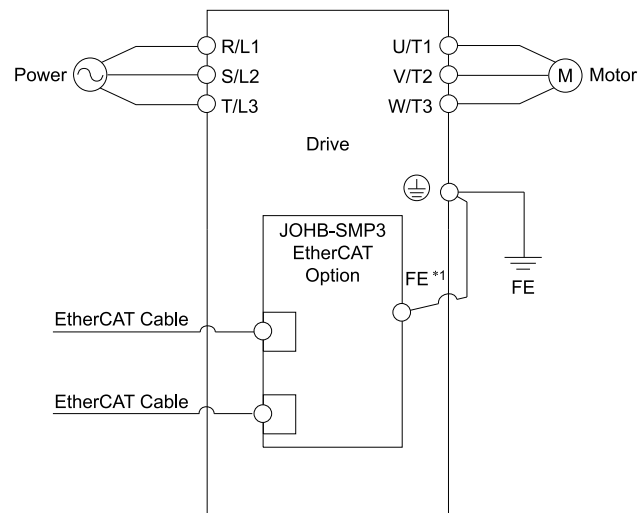

Figure 5.7 Option Connection Diagram

*1 Connect the specified ground wire for installations on 1000-series and GA500 drives. The ground wire is not necessary for installations on GA700, GA800, or CR700 drives.

◆ ESI File

Use the ESI file to easily register the option to an EtherCAT network. You can get the ESI file from these sources:

- Europe: <http://www.yaskawa.eu.com>
- Japan: <http://www.e-mechatronics.com>
- America: <http://www.yaskawa.com>
- Other areas: Contact Yaskawa or your nearest sales representative.

6 Related Drive Parameters

These parameters set the drive for operation with the option. Make sure that the parameter settings in this table are correct before you start network communications.

Note:

- Hex.: MEMOBUS addresses that you can use to change parameters over network communication are represented in hexadecimal numbers.
- Expert: The parameter that is available in Expert Mode only. When $A1-01 = 3$ [Access Level Selection = Expert Level], you can use the drive keypad to access and set Expert Mode parameters.

No. (Hex.)	Name	Description	Default (Range)
b1-01 (0180)	Frequency Reference Selection 1	<p>Selects the input method for frequency reference.</p> <p>0 : Keypad 1 : Analog Input 2 : Memobus/Modbus Communications 3 : Option PCB 4 : Pulse Train Input</p> <p>Note:</p> <ul style="list-style-type: none"> • Set $b1-01 = 3$ to use the master device to control the frequency reference of the drive. • The default setting is different for different drives. Refer to the instruction manual of your specific drive for more information. 	1 (0 - 4)
b1-02 (0181)	Run Command Selection 1	<p>Sets the input method for the Run command.</p> <p>0 : Keypad 1 : Digital Input 2 : Memobus/Modbus Communications 3 : Option PCB 7 : AUTO Command + Term Run 8 : AUTO Command + Serial Run 9 : AUTO Command + Option Run</p> <p>Note:</p> <ul style="list-style-type: none"> • Set $b1-02 = 3$ or 9 to start and stop the drive with the master device using serial communications. • The setting range is different for different drives. Refer to the instruction manual of your specific drive for more information. 	1 (0 - 9)

6 Related Drive Parameters

No. (Hex.)	Name	Description	Default (Range)
E2-04 (0311)	Motor Pole Count	Sets the number of motor poles. Note: • The setting range is different for different product series. –1000-Series: 2 - 48 –GA500, GA700, GA800: 2 - 120 • Necessary to set up when the Drive Profile DSP402 objects are used. Refer to <i>o1-03 [Frequency Display Unit Selection]</i> . • Parameter is available when <i>A1-02 = 0, 1, 2, 3, 4 [Control Method Selection = V/f Control, V/f Control with Encoder, Open Loop Vector, Closed Loop Vector, Advanced Open Loop Vector]</i> .	4 (2 - 120)
E4-04 (0324)	Motor 2 Motor Poles	Sets the number of poles for motor 2. Note: • The setting range is different for different product series. –1000-Series: 2 - 48 –GA500, GA700, GA800: 2 - 120 • Necessary to set up when the Drive Profile DSP402 objects are used. Refer to <i>o1-03 [Frequency Display Unit Selection]</i> . • Parameter is available in <i>A1-02 = 0, 1, 2, 3 [Control Method Selection = V/f Control, V/f Control with Encoder(PG Open Loop Vector, PG Vector Control(CLV))]</i> .	4 (2 - 120)
E5-04 (032C)	PM Motor Pole Count	Sets the number of PM motor poles. Note: • The setting range is different for different product series. –1000-Series: 2 - 48 –GA500, GA700, GA800: 2 - 120 • Necessary to set up when the Drive Profile DSP402 objects are used. Refer to <i>o1-03 [Frequency Display Unit Selection]</i> . • Parameter is available in <i>A1-02 = 5, 6, 7 [Control Method Selection = Open Loop Vector, PM Advanced Open Loop Vector, for PM PM Vector Control(CLV/ PM)]</i> .	Determined by E5-01 (2 - 120)
E9-08 (11EB)	PM Motor Pole Count	Sets the number of motor poles. Note: • The setting range is different for different product series. –GA500, GA700, GA800: 2 - 120 • Necessary to set up when the Drive Profile DSP402 objects are used. Refer to <i>o1-03 [Frequency Display Unit Selection]</i> . • Parameter is available in <i>A1-02 = 8 [Control Method Selection = EZ Vector Control (EZOLV)]</i> .	4 (2 - 120)
F6-01 (03A2)	Communication Error Selection	Selects drive response when the drive detects a <i>bUS [Option Communication Error]</i> error during communications with the option. 0 : Ramp to Stop 1 : Coast to Stop 2 : Fast Stop (Use C1-09) 3 : Alarm Only 4 : Alarm (Run at <i>d1-04</i>) 5 : Alarm - Ramp Stop Note: • When you set this parameter to 3 or 4, the drive will continue operation after it detects a fault. Separately prepare safety protection equipment and systems, for example fast-stop switches. • Refer to the drive manual to know if settings 4 and 5 are available. • The setting range for 1000-Series drives is different for different software versions. Refer to the Peripheral Devices & Options section of the drive instruction manual for more information. • Changes to this parameter take effect immediately. It is not necessary to cycle power on the drive.	1 (0 - 5)
F6-02 (03A3)	Comm External Fault (EF0) Detect	Selects the conditions at which <i>EF0 [Option Card External Fault]</i> is detected. 0 : Always Detected 1 : Detected during RUN Only	0 (0, 1)
F6-03 (03A4)	Comm External Fault (EF0) Select	Selects the operation of the drive when <i>EF0 [Option Card External Fault]</i> is detected. 0 : Ramp to Stop 1 : Coast to Stop 2 : Fast Stop (Use C1-09) 3 : Alarm Only Note: When you set this parameter to 3, the drive will continue operation after it detects a fault. Separately prepare safety protection equipment and systems, for example fast stop switches.	1 (0 - 3)
F6-06 (03A7)	Torque Reference/Limit by Comm	Sets the function that enables and disables the torque reference and torque limit received from the communication option. 0 : Disabled 1 : Enabled Note: • Control method availability of this parameter is different for different product series. –1000-Series Parameter is available in <i>A1-02 = 3, 6, 7 [Control Method Selection = Closed Loop Vector, PM Advanced Open Loop Vector, PM Closed Loop Vector]</i> . When you enable this parameter, <i>d5-01 [Torque Control Selection]</i> sets the drive to read the value as the Torque Limit value or the Torque Reference value. <i>d5-01 = 0 [Speed Control]:</i> Torque Limit <i>d5-01 = 1 [Torque Control]:</i> Torque Reference	0 (0, 1)

No. (Hex.)	Name	Description	Default (Range)
		<p>In $A1-02 = 6$ [Control Method Selection = PM Advanced Open Loop Vector], this value is read as the Torque Limit.</p> <p>–GA500 Parameter is available in $A1-02 = 2, 6, 8$ [Control Method Selection = Open Loop Vector, PM Advanced Open Loop Vector, EZ Vector Control]. The drive reads this value as the Torque Limit.</p> <p>–GA700, GA800 Parameter is available in $A1-02 = 2, 3, 4, 6, 7, 8$ [Control Method Selection = Open Loop Vector, Closed Loop Vector, Advanced Open Loop Vector, PM Advanced Open Loop Vector, PM Closed Loop Vector, EZ Vector Control]. When you enable this parameter, $d5-01$ [Torque Control Selection] sets the drive to read the value as the Torque Limit value or the Torque Reference value. $d5-01 = 0$ [Speed Control]: Torque Limit $d5-01 = 1$ [Torque Control]: Torque Reference In $A1-02 = 2, 8$ [Control Method Selection = Open Loop Vector, EZ Vector Control], this value is read as the Torque Limit.</p> <p>–CR700 In $A1-02 = 2, 3, 4$ [Control Method Selection = Open Loop Vector, Closed Loop Vector, Advanced Open Loop Vector], this value is read as the Torque Limit.</p> <ul style="list-style-type: none"> If the PLC does not supply a torque reference or torque limit when $F6-06 = 1$ [Torque Reference/Limit by Comm = Enabled], the motor cannot rotate. 	
F6-07 (03A8)	Multi-Step Ref @ NetRef/ComRef	<p>0 : Disable Multi-Step References 1 : Enable Multi-Step References</p> <p>Note: Default setting of $F6-07$ is 1 for GA500.</p>	0 (0, 1)
F6-08 (036A)	Comm Parameter Reset @Initialize	<p>Selects whether communication-related parameters $F6-xx$ and $F7-xx$ are set back to original default values when you use parameter $A1-03$ [Initialize Parameters] to initialize the drive.</p> <p>0 : No Reset - Parameters Retained 1 : Reset - Back to Factory Default</p> <p>Note: When you set $F6-08$ to 1 and you then use $A1-03$ to initialize the drive, the drive will not change this setting value.</p>	0 (0, 1)
F6-14 (03BB)	Bus Error Auto Reset	<p>Enables and disables the automatic reset of a <i>bUS</i> [Option Communication Error] fault.</p> <p>0 : Disabled 1 : Enabled</p> <p>Note: • This parameter is not available in all 1000-series drives. • Changes to this parameter take effect immediately. It is not necessary to cycle power on the drive.</p>	0 (0, 1)
F6-16 (0B8A)	Gateway Mode	<p>Sets the gateway mode operation and the number of connected slave drives.</p> <p>0 : Disabled 1 : Enabled: 1 Slave Drives 2 : Enabled: 2 Slave Drives 3 : Enabled: 3 Slave Drives 4 : Enabled: 4 Slave Drives</p> <p>Note: This parameter is not available for the 1000-series drives.</p>	0 (0 - 4)
H5-11 (043C)	Communications ENTER Function Selection (Function common to communication option)	<p>Sets when an Enter command is necessary to use MEMOBUS/Modbus communications to change parameter values.</p> <p>0 : Parameter changes are activated when ENTER command is written 1 : Parameter changes are activated immediately. No ENTER command is necessary.</p>	0 (0, 1)
o1-03 (0502)	Frequency Display Unit Selection	<p>Sets the display units for the frequency reference and output frequency.</p> <p>0 : 0.01Hz units 1 : 0.01% (100% = E1-04) 2 : min⁻¹ (Setting number of motor poles is required) 3 : User units (Set with o1-10, o1-11)</p> <p>Note: When you change $o1-03$, it also changes the units for input object 2010 (Hex.) (frequency reference), output object 2110 (Hex.) (output frequency), and 2200 (Hex.) (motor speed).</p>	Determined by A1-02 (0 - 3)

Table 6.1 Option Monitor

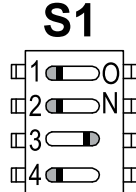
No.	Name	Description	Range
U4-75	Communication OPT Protocol	<p>Shows the setting of DIP switch S1.</p> <ul style="list-style-type: none"> • 70 = All switches OFF (incorrect for EtherCAT) • 74 = Switch 3 ON, all others OFF (correct for EtherCAT)  <p>S1</p> <p>• 71 to 73, 75 to 7F = Other switch positions that are incorrect for EtherCAT</p> <p>Note: This monitor will show the setting value only when you use a drive with the latest software version. Contact Yaskawa or your nearest sales representative for more information.</p>	00 - FF (Hex.)
U6-97	OPT SPARE 4	Shows option software version.	-
U6-98	First Fault	Shows first option fault.	-
U6-99	Current Fault	Shows current option fault.	-

7 Supported Modes of Operation

EtherCAT option supports Velocity mode (DSP 402) and Yaskawa specific mode (DS 301). DSP 402 mode is not available for converters. Operation modes DSP 402 and DS 301 are mutually exclusive. If you mix objects from both modes, it can cause incorrect operation. Also, do not transition the state of the EtherCAT state machine when the drive is in operation.

Cycle power to reset the mode.

DSP 402 is activated depending on the following constraints:

- If at least one of these DSP 402 objects is assigned to RxPDO Mapping:
 - 6040 (Hex.), 6042 (Hex.), 6046 (Hex.), 6048 (Hex.), 6049 (Hex.), 604A (Hex.)
- If the EtherCAT state machine is NOT in the SAFEOP or OP state and an SDO write request is performed on the DSP 402 6040 (Hex.) Controlword or DSP 402 6042 (Hex.) v1 target velocity.
- In all other cases, you can access the vendor-specific control word normally.

8 Object Dictionary

◆ Object Dictionary Overview

These sections are in the Object Dictionary:

- Communication Profile Objects
- Manufacturer Specific Profile Objects
- Drive and Motion Profile Objects

■ Communication Profile Objects (DS 301)

Index (Hex.)	Name	Ref.
1000	Device Type	24
1001	Error Register	24
1003	Pre-defined Error Field	24
1008	Manufacturer Device Name	25
1009	Manufacturer Hardware Version	25
100A	Manufacturer Software Version	25
1010	Store Parameters	25

Index (Hex.)	Name	Ref.
1011	Restore Default Parameters	26
1018	Identity Object	26
1600 - 1650	Receive PDO Mapping	27
1A00 - 1A50	Transmit PDO Mapping	27
1C00	Sync Manager Communication Type	28
1C12	Sync Manager RxPDO assign	28
1C13	Sync Manager TxPDO assign	28

■ Manufacturer Specific Profile Objects (DS 301)

Index (Hex.)	Name	Ref.
2000	Operation Command	28
2010	Speed Reference/Speed Limit	29
2020	Torque Reference/Torque Limit	29
2030	Torque Compensation	30
2040	MEMOBUS/Modbus Read Request	30
2050	MEMOBUS/Modbus Write Request	30
2051	Advanced MEMOBUS/Modbus Write Response	31
2060	MEMOBUS/Modbus Unlimited Enter Command	31
2061	MEMOBUS/Modbus Unlimited Enter Command 2	32
2070	MEMOBUS/Modbus Limited Enter Command	32
2071	MEMOBUS/Modbus Limited Enter Command 2	32
2080	Selectable (default: none)	32
2090	Selectable (default: none)	32
20A0	Selectable (default: none)	32
20B0	Selectable (default: none)	32
20C0	Selectable (default: none)	32
20D0	FM analog output 1	34
20E0	AM analog output 2	34
20F0	Multi-function DO output	34
3000	Selectable (default: none)	-
3100	Selectable (default: none)	-
2100	Drive Status	35
2110	Output Frequency	35
2120	Output Current	36
2130	Output Torque Reference	36
2140	MEMOBUS/Modbus Read Response	36
2150	MEMOBUS/Modbus Write Response	37
2151	Advanced MEMOBUS/Modbus Write Response	37
2155	PDO Parameter Write Response	37
2160	MEMOBUS/Modbus Not Limited Enter Command Response	37
2180	Selectable (default: Input terminal status)	38
2190	Selectable (default: Analog input 1 monitor)	38
21A0	Selectable (default: none)	38
21B0	Selectable (default: none)	38

Index (Hex.)	Name	Ref.
21C0	Selectable (default: none)	38
21E0	Selectable (default: none)	38
21F0	Selectable (default: none)	38
2200	Motor Speed	38
2210	DC Bus Voltage	39
2220	Analog input monitor A1	39
2240	Analog input monitor A2	39
2260	Analog input monitor A3	39
2270	Inverter DI Input	39
2301	Error Register	40
2318	Drive Information	40
251x	Main Parameter Group A	40
252x	Main Parameter Group B	41
253x	Main Parameter Group C	41
254x	Main Parameter Group D	42
255x	Main Parameter Group E	42
256x	Main Parameter Group F	42
258x	Main Parameter Group H	43
25Cx	Main Parameter Group L	43
25Ex	Main Parameter Group N	43
25Fx	Main Parameter Group O	44
261x	Main Parameter Group Q	44
262x	Main Parameter Group R	45
264x	Main Parameter Group T	45
265x	Main Parameter Group U	45
2E00	Gateway Mode Communication Settings	46
2E01 - 2E04	Gateway Slave Drive Operation	46
2EFF	Gateway MEMOBUS/Modbus Read/Write Request	47
2F01 - 2F04	Gateway Slave Drive Status	47
2FFF	Gateway MEMOBUS/Modbus Read/Write Response	47
4001	Option Info + Status Record	48
4010	Store Parameters	48
4011	Restore Default Parameters	49

■ Converter Specific Profile Objects

Index (Hex.)	Name	Ref.
5000	Regenerated Energy	49
5001	Input Voltage	49
5002	Current Limit	50

Index (Hex.)	Name	Ref.
5003	AC Power	50
5004	Consumed Energy	50
5005	DC Bus Voltage Reference	50

■ Drives and Motion Specific Profile Objects (DSP 402)

Table 8.1 Common Entries

Index (Hex.)	Name	Ref.
60FD	Digital Inputs	58
60FE	Digital Outputs	58
6502	Supported Drive Modes	59

Table 8.2 Device Control

Index (Hex.)	Name	Ref.	Index (Hex.)	Name	Ref.
6040	Controlword	54	6060	Modes of Operation	57
6041	Status Word	54	6061	Modes of Operation Display	57

Table 8.3 Velocity Mode

Index (Hex.)	Name	Ref.	Index (Hex.)	Name	Ref.
6042	vl target velocity	55	6049	vl velocity deceleration	56
6043	vl velocity demand	55	604A	vl velocity quick stop	56
6044	vl control effort	55	604C	vl dimension factor	56
6046	vl velocity min max amount	55	604D	vl pole number	57
6048	vl velocity acceleration	56			

◆ Communication Profile Objects (DS 301)

■ 1000 (Hex.): Device Type

This object describes the type of the device and its functionality. It has one 16-bit field that describes the device profile used and a second 16-bit field that gives additional information about optional functionality.

Bit 0 - 15	Device Profile Number = 0192 (Hex.) (402) (static) Device Profile Number = 0000 (Hex.) (402) (static) (For D1000 and R1000)
Bit 16 - 23	Type = 01 (Hex.) Type = 00 (Hex.) (For D1000 and R1000)
Bit 24 - 31	Mode Bits (Vendor specific) = 00 (Hex.)

Index (Hex.)	Subindex	Content	Access	PDO Mapping	Data Type	Value
1000	0	Device Type	Read Only	No	UNS32	-

■ 1001 (Hex.): Error Register

This register shows the fault status of the device. If any errors occur in the device, bit 0 (generic error) is set to one.

0	No error
1	Generic error

Index (Hex.)	Subindex	Content	Access	PDO Mapping	Data Type	Value (Range)
1001	0	Error Register	Read Only	No	UNS8	0 (0 - 1)

■ 1003 (Hex.): Pre-defined Error Field

This register gives a history of errors that occurred in the drive and have been signaled via the Emergency object. Subindex 0 contains the number of errors. Subindices 1 to FF contain a rolling list of error codes where subindex 1 always contains the last error that occurred.

For Error Codes, please refer to [Emergency Error Codes on page 68](#).

The number of valid logged errors in the subindex is 01 - FE (Hex.). To reset the error field, write 0 to subindex 0.

Index (Hex.)	Subindex	Content	Access	PDO Mapping	Data Type	Value (Range)
1003	0	Number of errors	Read Write	No	UNS8	00 (Hex.) (00 - FF (Hex.))
1003	1	Standard error field (Emergency error code)	Read Only	No	UNS32	0000 (Hex.) (0000 - FFB8 (Hex.))

■ 1008 (Hex.): Manufacturer Device Name

This object contains the manufacturer device name.

Index (Hex.)	Subindex	Content	Access	PDO Mapping	Data Type	Value
1008	0	Manufacturer Device Name	Read Only	No	String	-

■ 1009 (Hex.): Manufacturer Hardware Version

This object contains the manufacturer device name.

Index (Hex.)	Subindex	Content	Access	PDO Mapping	Data Type	Value
1009	0	Manufacturer Hardware Version	Read Only	No	String	x.y

Note:

x: Major hardware version

y: Minor hardware revision assigned during production

■ 100A (Hex.) Manufacturer Software Version

This object contains the manufacturer software version.

Index (Hex.)	Subindex	Content	Access	PDO Mapping	Data Type	Value
100A	0	Manufacturer Software Version	Read Only	No	String	-

■ 1010 (Hex.): Store Parameters

To save the Communication Option settings in the non-volatile memory, write "save" to this object.

Signature	MSB			LSB
ASCII	e	v	a	s
Hex	65	76	61	73

Actions: Will issue Limited Enter command. Writes data into the EEPROM of the drive and enables the data in RAM at the same time. If you cycle the power supply, the parameter changes will stay.

Note:

You can write the EEPROM to the drive a maximum of 100,000 times. Do not frequently execute the Enter command that is written to EEPROM.

Table 8.4 Non-volatile Stored Parameters (NVS Parameters)

CANopen Object (Hex.)	Default Value (Hex.)	EEPROM Size	CANopen Object (Hex.)	Default Value (Hex.)	EEPROM Size
2080:2	FFFFFFFF	32 bit	2190:2	004E	16 bit
2090:2	FFFF	16 bit	21A0:2	FFFF	16 bit
20A0:2	FFFF	16 bit	21B0:2	FFFF	16 bit
20B0:2	FFFF	16 bit	21C0:2	FFFF	16 bit
20C0:2	FFFF	16 bit	21E0:2	FFFF	16 bit
3000:2	FFFF	16 bit	21F0:2	FFFFFFFF	32 bit
3100:2	FFFF	16 bit	604C:1	00000001	32 bit
2180:2	0049	16 bit	604C:2	00000001	32 bit

Index (Hex.)	Subindex	Content	Access	PDO Mapping	Data Type	Value
1010	0	Store Parameters	Read only	No	UNS8	1
1010	1	Save all parameters	Read Write	No	UNS32	01 (Hex.) (Save on command)

■ 1011 (Hex.): Restore Default Parameters

To restore the Communication Option default settings, write "load" to this object.

Signature	MSB			LSB
ASCII	d	a	o	l
Hex	64	61	6F	6C

Actions: Option will write value = 2220 to *A1-03 [Initialize Parameters]* (INVR: 0103 (Hex.)) together with an EEPROM ENTER command.

Note:

You can write the EEPROM to the drive a maximum of 100,000 times. Do not frequently execute the Enter command that is written to EEPROM.

Table 8.5 Non-volatile Stored Parameters (NVS Parameters)

CANopen Object (Hex.)	Default Value (Hex.)	EEPROM Size	CANopen Object (Hex.)	Default Value (Hex.)	EEPROM Size
2080:2	FFFFFFFF	32 bit	2190:2	004E	16 bit
2090:2	FFFF	16 bit	21A0:2	FFFF	16 bit
20A0:2	FFFF	16 bit	21B0:2	FFFF	16 bit
20B0:2	FFFF	16 bit	21C0:2	FFFF	16 bit
20C0:2	FFFF	16 bit	21E0:2	FFFF	16 bit
3000:2	FFFF	16 bit	21F0:2	FFFFFFFF	32 bit
3100:2	FFFF	16 bit	604C:1	00000001	32 bit
2180:2	0049	16 bit	604C:2	00000001	32 bit

Index (Hex.)	Subindex	Content	Access	PDO Mapping	Data Type	Value
1011	0	Restore Default Parameters	Read Only	No	UNS8	1
1011	1	Restore all default parameters	Read Write	No	UNS32	01 (Hex.) (Restore on command)

■ 1018 (Hex.): Identity Object

This object contains general information about the drive.

Vendor ID

Values: 00000539 (Hex.) for "Yaskawa Electric Corporation, Japan"

Product Code

The value is the first three letters of the product name followed by a running number. This value is in ASCII format. Example: Values: Value 41313030 (Hex.) (ASCII: A100) when you connect an A1000 drive.

Revision History

EtherCAT Option software revision number

Index (Hex.)	Subindex	Content	Access	PDO Mapping	Data Type	Value
1018	0	Number of entries	Read Only	No	UNS8	4
1018	1	Vendor ID	Read Only	No	UNS32	00000539 (Hex.)
1018	2	Product code	Read Only	No	UNS32	Depends on manufacturer device
1018	3	Revision number	Read Only	No	UNS32	-
1018	4	EtherCAT Option serial number	Read Only	No	UNS32	-

■ 1600 (Hex.), 1629 (Hex.), 1650 (Hex.): Receive PDO Mapping

These objects are automatically filled by the master.

Index (Hex.)	Subindex	Content	Access	PDO Mapping	Data Type	Value (Range)
1600, 1629, 1650	0	Number of entries	Read Write	No	UNS8	0 (0 - 8)
1600, 1629, 1650	1	Mapped Object #1	Read Write	No	UNS32	-
1600, 1629, 1650	2	Mapped Object #2	Read Write	No	UNS32	-
1600, 1629, 1650	n	Mapped Object #n	Read Write	No	UNS32	-

■ 1601 (Hex.) to 1628 (Hex.): Receive PDO Mapping

These objects are automatically filled by the master.

Index (Hex.)	Subindex	Content	Access	PDO Mapping	Data Type	Value (Range)
1601 - 1628	0	Number of entries	Read Write	No	UNS8	0 (0 - 2)
1601 - 1628	1	Mapped Object #1	Read Write	No	UNS8	-
1601 - 1628	2	Mapped Object #2	Read Write	No	UNS8	-
1601 - 1628	n	Mapped Object #n	Read Write	No	UNS8	-

■ 1A00 (Hex.), 1A29 (Hex.), 1A50 (Hex.): Transmit PDO Mapping

These objects are automatically filled by the master.

Index (Hex.)	Subindex	Content	Access	PDO Mapping	Data Type	Value (Range)
1A00, 1A50	0	Number of entries	Read Write	No	UNS8	0 (0 - 8)
1A29	0	Number of entries	Read Write	No	UNS8	6 (0 - 6)
1A00, 1A29, 1A50	1	Mapped Object #1	Read Write	No	UNS32	-
1A00, 1A29, 1A50	2	Mapped Object #2	Read Write	No	UNS32	-
1A00, 1A29, 1A50	n	Mapped Object #n	Read Write	No	UNS32	-

■ 1A01 (Hex.) to 1A28 (Hex.): Transmit PDO Mapping

These objects are automatically filled by the master.

Index (Hex.)	Subindex	Content	Access	PDO Mapping	Data Type	Value (Range)
1A01 - 1A28	0	Number of entries	Read Write	No	UNS8	0 (0 - 2)
1A01 - 1A28	1	Mapped Object #1	Read Write	No	UNS32	-
1A01 - 1A28	2	Mapped Object #2	Read Write	No	UNS32	-
1A01 - 1A28	n	Mapped Object #n	Read Write	No	UNS32	-

■ 1C00 (Hex.): Sync Manager Communication Type

Index (Hex.)	Subindex	Content	Access	PDO Mapping	Data Type	Value
1C00	0	Number of entries	Read Only	No	UNS8	4
1C00	1	Mailbox receive	Read Only	No	UNS8	1
1C00	2	Mailbox send	Read Only	No	UNS8	2
1C00	3	Process data output	Read Only	No	UNS8	3
1C00	4	Process data input	Read Only	No	UNS8	4

■ 1C12 (Hex.): Sync Manager RxPDO Assign

Index (Hex.)	Subindex	Content	Access	PDO Mapping	Data Type	Value (Range)
1C12	0	Number of entries	Read Write	No	UNS8	1 (0 - 4)
1C12	1	Assigned RxPDO #1	Read Write	No	UNS16	1600 (Hex.)
1C12	2	Assigned RxPDO #1	Read Write	No	UNS16	-
1C12	3	Assigned RxPDO #1	Read Write	No	UNS16	-
1C12	4	Assigned RxPDO #1	Read Write	No	UNS16	-

■ 1C13 (Hex.): Sync Manager TxPDO Assign

Index (Hex.)	Subindex	Content	Access	PDO Mapping	Data Type	Value (Range)
1C13	0	Number of entries	Read Write	No	UNS8	1 (0 - 4)
1C13	1	Assigned TxPDO #1	Read Write	No	UNS16	1A00 (Hex.)
1C13	2	Assigned TxPDO #2	Read Write	No	UNS16	-
1C13	3	Assigned TxPDO #3	Read Write	No	UNS16	-
1C13	4	Assigned TxPDO #4	Read Write	No	UNS16	-

◆ Manufacturer Specific Profile Objects (DS301) Details

The EtherCAT option offers the manufacturer specific objects listed below. These objects are specific to Yaskawa products and are not available on other EtherCAT products.

The manufacturer specific objects list has static objects and configurable objects. You can link these objects to drive parameters, monitors, or MEMOBUS/Modbus registers to determine the content of configurable objects.

■ 2000 (Hex.): Operation Command

This object starts and stops the drive, controls the multi-function digital input terminals, and triggers and resets faults.

Bit No.	Description	Function
0	<i>H5-12 = 0 [Run Command Method Selection = FWD/Stop, REV/Stop]: Forward Run Command</i> <i>H5-12 = 1 [Run/Stop, FWD/REV]: Run Command</i>	0: Stop, 1: Forward run 0: Stop, 1: Run
1	<i>H5-12 = 0 [Run Command Method Selection = FWD/Stop, REV/Stop]: Reverse Run Command</i> <i>H5-12 = 1 [Run/Stop, FWD/REV]: Forward/Reverse</i>	0: Stop, 1: Reverse run 0: Forward, 1: Reverse
2	External Fault (EF0)	1: External Fault Input (EF0)
3	Fault Reset	1: Fault Reset

Bit No.	Description	Function
4	Terminal S1 Function	Multi-Function Input 1
5	Terminal S2 Function	Multi-Function Input 2
6	Terminal S3 Function	Multi-Function Input 3
7	Terminal S4 Function	Multi-Function Input 4
8	Terminal S5 Function	Multi-Function Input 5
9	Terminal S6 Function	Multi-Function Input 6
10	Terminal S7 Function	Multi-Function Input 7
11	Terminal S8 Function	Multi-Function Input 8
12 - 15	Reserved	Reserved

Index (Hex.)	Subindex	Content	Access	PDO Mapping	Data Type	Value
2000	0	Number of entries	Read Only	No	UNS8	2
2000	1	Value	Read Write	Rx/Tx	UNS16	-
2000	2	MEMOBUS/Modbus address Mapped to MEMOBUS/Modbus address 0001 (Hex.) (Operation command and multi-function inputs)	Read Only	No	UNS16	0001 (Hex.)

■ 2010 (Hex.): Speed Reference/Speed Limit

Note:

This object is not available for D1000 and R1000.

Sets the speed reference or speed limit. The unit of this value depends on the setting of the drive parameter *o1-03* [*Frequency Display Unit Selection*]. Refer to [Related Drive Parameters on page 19](#) for information.

The drive uses this value as the frequency reference for torque control [*d5-01* = 1] or as the frequency reference limit in speed control [*d5-01* = 0].

Note:

The availability of the torque control function depends on the drive and the selected control method. For more information, refer to the Technical Manual for your drive.

Index (Hex.)	Subindex	Content	Access	PDO Mapping	Data Type	Value
2010	0	Number of entries	Read Only	No	UNS8	2
2010	1	Value	Read Write	Rx/Tx	UNS16	0
2010	2	MEMOBUS/Modbus address Mapped to MEMOBUS/Modbus address 0002 (Hex.) (Frequency reference)	Read Only	No	UNS16	0002 (Hex.)

■ 2020 (Hex.): Torque Reference/Torque Limit

Note:

This object is not available for D1000 and R1000.

Sets the torque reference or torque limit in units of 0.1%. Only usable when *F6-06* = 1 [*Torque Reference/Limit by Comm* = Enabled]. Refer to [Related Drive Parameters on page 19](#) for information.

The drive uses this value as the torque reference for torque control [*d5-01* = 1] or as the torque limit in speed control [*d5-01* = 0].

Note:

The availability of the torque control function depends on the drive and the selected control method. For more information, refer to the Technical Manual for your drive.

Index (Hex.)	Subindex	Content	Access	PDO Mapping	Data Type	Value (Range)
2020	0	Number of entries	Read Only	No	UNS8	2
2020	1	Value	Read Write	Rx/Tx	UNS16	0 (0 - 3000)
2020	2	MEMOBUS/Modbus address Mapped to MEMOBUS/Modbus address 0004 (Hex.) (Torque ref/limit)	Read Only	No	UNS16	0004 (Hex.)

■ 2030 (Hex.): Torque Compensation

Note:

This object is not available for D1000 and R1000.

This object sets the torque compensation in units of 0.1%.

Note:

Only usable when $F6-06 = 1$ [Torque Reference/Limit by Comm = Enabled].

Index (Hex.)	Subindex	Content	Access	PDO Mapping	Data Type	Value (Range)
2030	0	Number of entries	Read Only	No	UNS8	2
2030	1	Value	Read Write	Rx/Tx	UNS16	0 (0 - 2000)
2030	2	MEMOBUS/Modbus address Mapped to MEMOBUS/Modbus address 0005 (Hex.) (Torque compensation)	Read Only	No	UNS16	0005 (Hex.)

■ 2040 (Hex.): MEMOBUS/Modbus Read Request

Objects 2040 (Hex) and 2140 (Hex) are used as a pair to read out the contents of drive's MEMOBUS/Modbus registers.

The PLC reads the drive output frequency at register at 2040 (Hex.). After sending a MEMOBUS/Modbus Read Request to the drive, you can read the MEMOBUS/Modbus register content from object 2140 (Hex.).

You must write the address of the MEMOBUS/Modbus in bytes 3 and 4 of Subindex 1, and set bytes 1 and 2 to 0.

Signature	MSB			LSB
Byte	4	3	2	1
Hex	yy	xx	00	00

For more information about MEMOBUS/Modbus addresses and data, refer to the Technical Manual for your drive.

Index (Hex.)	Subindex	Content	Access	PDO Mapping	Data Type	Value
2040	0	Number of entries	Read Only	No	UNS8	1
2040	1	MEMOBUS/Modbus read request	Read Write	Rx/Tx	UNS32	0

■ 2050 (Hex.): MEMOBUS/Modbus Write Request

Object 2050 (Hex.) writes the contents of the drive MEMOBUS/Modbus registers. When you write this object, it will automatically issue an Unlimited Enter command, which applies changes immediately. This happens regardless of the Communications ENTER Function Selection (*H5-11 [Comm ENTER Command Mode]*).

The automatic ENTER command makes the writing process slower, but it also makes the process of writing registers less complicated. For these reasons, Yaskawa recommends that you use object 2050 (Hex.) for most applications.

You must write the address of the MEMOBUS/Modbus in bytes 3 and 4 of Subindex 1, and you must write the value to bytes 1 and 2.

Signature	MSB			LSB
Byte	4	3	2	1
Hex	Address		Value	

For more information about MEMOBUS/Modbus addresses and data, refer to the Technical Manual for your drive.

Index (Hex.)	Subindex	Content	Access	PDO Mapping	Data Type	Value
2050	0	Number of entries	Read Only	No	UNS8	1
2050	1	MEMOBUS/Modbus write request	Read Write	Rx/Tx	UNS32	0

■ 2051 (Hex.): Advanced MEMOBUS/Modbus Write Response

Object 2051(Hex.) is used to write the contents of drive's MEMOBUS/Modbus registers. Writing this object does not automatically issue an enter command. You can set $H5-11 = 0$ [*Comm ENTER Command Mode = ENTER Command Required*] to set an internal automatic ENTER command that will immediately apply changes to registers for all fieldbus objects.

Use object 2051 without automatic ENTER commands ($H5-11=0$), to increase the speed of the writing process. You must issue ENTER commands separately to apply changes to registers. YASKAWA AC Drives check for inconsistencies when you issue an ENTER command. They do not check before you issue the command. This means that the drive will not always report incorrect parameter settings correctly over the fieldbus (refer to [2151 \(Hex.\): Advanced MEMOBUS/Modbus Write Response on page 37](#) for more information). For these reasons, Yaskawa recommends that you use object 2051 (Hex.) only for applications where the writing speed is of critical importance.

You must write the address of the MEMOBUS/Modbus in bytes 3 and 4 of Subindex 1, and you must write the value to bytes 1 and 2.

Signature	MSB			LSB
Byte	4	3	2	1
Hex	Address		Value	

For more information about MEMOBUS/Modbus addresses and data, refer to the Technical Manual for your drive.

Index (Hex.)	Subindex	Content	Access	PDO Mapping	Data Type	Value
2051	0	Number of entries	Read Only	No	UNS8	1
2051	1	MEMOBUS/Modbus write request	Read Write	Rx/Tx	UNS32	0

■ 2060 (Hex.): MEMOBUS/Modbus Unlimited ENTER Command

To activate parameter changes, you must execute this ENTER command. This ENTER command activates parameters in the drive RAM only. If you cycle power to the drive, you will lose your parameter changes. When you change more than one parameter, you can send only one ENTER command after the last parameter change.

It is not necessary to execute the ENTER command each time you make a parameter change. You can execute this ENTER command as many times as necessary. There are no limits.

Note:

You can execute the ENTER command according to the following settings except for this ENTER command.

- Activating the Communications ENTER Function ($H5-11 = 1$ [*Comm ENTER Command Mode = ENTER Command Not Required*]).
- Using object 2050 (Hex.) to issue MEMOBUS write commands.

To save the data, input "save" (73H + 61H + 76H + 65H).

Signature	MSB			LSB
ASCII	e	v	a	s
Hex	65	76	61	73

Index (Hex.)	Subindex	Content	Access	PDO Mapping	Data Type	Value (Range)
2060	0	Limited ENTER command Mapped to MEMOBUS/Modbus address 0910 (Hex.) (Un-Memorized ENTER command)	Read Write	Rx/Tx	UNS32	00000001 (Hex.) (00000001, 65766173 (Hex.))

■ 2061 (Hex.): MEMOBUS/Modbus Unlimited ENTER Command 2

To activate parameter changes, you must execute this ENTER command. This ENTER command activates parameters in the drive RAM only. If you cycle power to the drive, you will lose your parameter changes. When you change more than one parameter, you can send only one ENTER command after the last parameter change. It is not necessary to execute the ENTER command each time you make a parameter change. You can execute this ENTER command as many times as necessary. There are no limits.

Note:

You can execute the ENTER command according to the following settings except for this ENTER command.

- Activating the Communications ENTER Function ($H5-11 = 1$ [*Comm ENTER Command Mode = ENTER Command Not Required*]).
- Using object 2050 (Hex.) to issue MEMOBUS write commands.

To execute this type of ENTER command, toggle subindex 0 from 0 to 1.

Index (Hex.)	Subindex	Content	Access	PDO Mapping	Data Type	Value (Range)
2061	0	Unlimited ENTER command 2 Mapped to MEMOBUS/Modbus address 0910 (Hex.) (Un-Memorized ENTER command)	Read Write	Rx/Tx	UNS8	0 (Hex.) (0, 1 (Hex.))

■ 2070 (Hex.): MEMOBUS/Modbus Limited ENTER Command

To activate parameter changes, you must execute this ENTER command. The limited ENTER command activates parameters in the drive RAM and saves them to the EEPROM. If the drive loses power or if you cycle the power supply, the drive will operate using the saved parameters. When you change more than one parameter, you can send only one ENTER command after the last parameter change. It is not necessary to execute the ENTER command each time you make a parameter change.

Note:

You can execute this command approximately 100,000 times.

To save the data, input "save" (73H + 61H + 76H + 65H).

Signature	MSB			LSB
ASCII	e	v	a	s
Hex	65	76	61	73

Index (Hex.)	Subindex	Content	Access	PDO Mapping	Data Type	Value (Range)
2070	0	Limited ENTER command Mapped to MEMOBUS/Modbus address 0900 (Hex.) (Memorized ENTER command)	Read Write	No	UNS32	00000001 (Hex.) (00000001, 65766173 (Hex.))

■ 2071 (Hex.): MEMOBUS/Modbus Limited ENTER Command 2

To activate parameter changes, you must execute this ENTER command. The limited ENTER command activates parameters in the drive RAM and saves them to the EEPROM. If the drive loses power or if you cycle the power supply, the drive will operate using the saved parameters. When you change more than one parameter, you can send only one ENTER command after the last parameter change. It is not necessary to execute the ENTER command each time you make a parameter change.

Note:

You can execute this command approximately 100,000 times.

To execute this type of ENTER command, toggle subindex 0 from 0 to 1.

Index (Hex.)	Subindex	Content	Access	PDO Mapping	Data Type	Value (Range)
2071	0	Limited ENTER command 2 Mapped to MEMOBUS/Modbus address 0900 (Hex.) (Memorized ENTER command)	Read Write	No	UNS8	0 (Hex.) (0, 1 (Hex.))

■ 2080 (Hex.) to 3100 (Hex.): Freely Configurable Input Objects

These objects can write selectable MEMOBUS content through fieldbus communication. You can assign any MEMOBUS address to this object. After you assign the address, you can use PDO or SDO until Power Off to

write the content of this MEMOBUS address. Although this object can be read, please note that this is not necessarily the content of the register. Subindex 2 determines the MEMOBUS address to be written.

Subindex 1 reads and writes the content.

For more information about MEMOBUS/Modbus addresses and data, refer to the Technical Manual for your drive.

2080 (Hex.): Freely Configurable Input Object

Use this object to write up to two registers at the same time. To write to only one register, set the other register value to FFFF (Hex.).

Index (Hex.)	Subindex	Content	Access	PDO Mapping	Data Type	Value (Range)
2080	0	Number of entries	Read Only	No	UNS8	2
2080	1	Value	Read Write	Rx/Tx	UNS32	-
2080	2	MEMOBUS/Modbus address of content 1 and 2	Read Write	No	UNS32	FFFF (Hex.) + FFFF (Hex.) (00000000 - FFFFFFFF (Hex.))

2090 (Hex.) to 3100 (Hex.): Freely Configurable Input Objects

Index (Hex.)	Subindex	Content	Access	PDO Mapping	Data Type	Value (Range)
2090 20A0 20B0 20C0 3000 3100	0	Number of entries	Read Only	No	UNS8	2
2090 20A0 20B0 20C0 3000 3100	1	Value	Read Write	Rx/Tx	UNS16	-
2090 20A0 20B0 20C0 3000 3100	2	MEMOBUS/Modbus address of content	Read Write	No	UNS16	FFFF (Hex.) (0000 - FFFF (Hex.))

Limitations of Object Content Selection

Consider these limitations when you set the content of an object.

- You cannot switch the communication option to the Operational state until the content selection process is complete. If the process is incomplete, it will trigger an emergency message (code 6301 (Hex.))
- When object content selection is ongoing, you cannot send a different request or command, including Run, to the drive. If you send a different request or command, it will trigger an error message or an emergency message (code 6301 (Hex.)).
- For 4 byte input objects, you can link MEMOBUS/Modbus register numbers up to 00FF (Hex.) in any combination. When you link MEMOBUS/Modbus register numbers from 0100 (Hex.) to a 4 byte object, the MEMOBUS/Modbus register numbers must be consecutive.

Mapped Register 1	Mapped Register 2	Combination possible?
0007 (Hex.)	0009 (Hex.)	Possible
0201 (Hex.)	0202 (Hex.)	Possible
0202 (Hex.)	0201 (Hex.)	No
0201 (Hex.)	0203 (Hex.)	No
0202 (Hex.)	0202 (Hex.)	No
0200 (Hex.)	FFFF (Hex.)	Possible
FFFF (Hex.)	FFFF (Hex.)	Possible

- Register numbers must not be consecutive for 4-byte output objects.
- You cannot map a MEMOBUS/Modbus register to two or more objects at the same time.
- MEMOBUS/Modbus registers 0001 (Hex.), 0002 (Hex.), 0004 (Hex.), 0005 (Hex.), 0007 (Hex.), 0008 (Hex.), and 0014 (Hex.) are already linked to not changeable input objects. You cannot link them to any object with selectable content. If you try to map one of those registers to an input object, it will trigger an error message.

Example

- To map the drive output power monitor (*UI-08*, 0047 (Hex.)) to output object 21A0 (Hex.), write 0047 (Hex.) to subindex 2 of object 21A0 (Hex.).
- To map the speed reference 1 (*dI-01*, 0280 (Hex.)) to input object 2090 (Hex.), write 0280 (Hex.) to subindex 2 of object 2090 (Hex.).
- To map the input terminal status (*UI-10*, 0049 (Hex.)) and output terminal status (*UI-11*, 004A (Hex.)) to output object 21F0 (Hex.) (4 Byte), write 0049 (Hex.) to the higher and 004A (Hex.) to the lower word of object 2090 (Hex.), subindex 2.

■ **20D0 (Hex.): FM analog output 1**

This object controls the FM analog terminal output value.

Index (Hex.)	Subindex	Content	Access	PDO Mapping	Data Type	Value
20D0	0	Number of entries	Read Only	No	UNS8	2
20D0	1	Value	Read Write	Rx/Tx	UNS16	-
20D0	2	MEMOBUS/Modbus address Mapped to MEMOBUS/Modbus address 0007 (Hex.) (FM analog output 1)	Read Only	No	UNS16	0007 (Hex.)

■ **20E0 (Hex.): AM analog output 1**

Note:

This object is not available for GA500.

This object controls the AM analog terminal output value.

Index (Hex.)	Subindex	Content	Access	PDO Mapping	Data Type	Value
20E0	0	Number of entries	Read Only	No	UNS8	2
20E0	1	Value	Read Write	Rx/Tx	UNS16	-
20E0	2	MEMOBUS/Modbus address Mapped to MEMOBUS/Modbus address 0008 (Hex.) (AM analog output 2)	Read Only	No	UNS16	0008 (Hex.)

■ **20F0 (Hex.): Multi-function DO Output**

This object controls the multi-function DO outputs.

Signature	Bit	GA700	Supplementary Information
LSB	0	Terminals M1-M2	Refer to MEMOBUS/Modbus address 0009 (Hex.) bit 0 to bit 7 in the Technical Manual of your drive for more information.
	1	Terminals M3-M4	
	2	Terminals P1-C1	
	3	Terminals P2-C2	
	4	Reserved	
	5	Reserved	
	6	1: bit 7 function is enabled	
	7	Faulty Relay MA/MB-MC	
MSB	8 - 15	Reserved	-

Value	Description
1	ON
0	OFF

Index (Hex.)	Subindex	Content	Access	PDO Mapping	Data Type	Value
20F0	0	Number of entries	Read Only	No	UNS8	2
20F0	1	Value	Read Write	Rx/Tx	UNS16	-
20F0	2	MEMOBUS/Modbus address Mapped to MEMOBUS/Modbus address 0009 (Hex.) (Multi-function DO)	Read Only	No	UNS16	0009 (Hex.)

■ 2100 (Hex.): Drive Status

These objects monitor the drive status. The value in object 2100 (Hex.) is not filtered.

Bit	Description	Function
0	During Run	1: During Run 0: During Stop
1	During Zero Speed	1: During Zero Speed
2	During Reverse Running	1: During Reverse Running 0: During Forward Running
3	During Fault Reset Signal Input	1: During Fault Reset Signal Input
4	During Speed Agree	1: During Speed Agree
5	During Drive Ready	1: During Drive Ready 0: Not Ready
6	During Alarm	1: During Alarm
7	During Fault	1: During Fault
8	During Operation Error	1: During Operation Error
9	During Momentary Power Loss	1: During Momentary Power Loss 0: During Power Loss
10	NetCtrl Status	1: NetCtrl
11	Digital Output 1 Status (function set in drive parameter <i>H2-01 [Term M1-M2 Function Selection]</i>)	1: ON 0: OFF
12	Digital Output 2 Status (function set in drive parameter <i>H2-02 [Term M3-M4 Function Selection]</i>)	1: ON 0: OFF
13	Digital Output 3 Status (function set in drive parameter <i>H2-03 [Term M5-M6 Function Selection]</i>)	1: ON 0: OFF
14	Motor 2 Selected	1: Motor 2 Selected (Not available for D1000 and R1000)
15	Zero-Servo End	1: Zero-Servo End (Not available for D1000 and R1000)

Index (Hex.)	Subindex	Content	Access	PDO Mapping	Data Type	Value (Range)
2100	0	Number of entries	Read Only	No	UNS8	2
2100	1	Value	Read Only	Tx	UNS16	-
2100	2	MEMOBUS/Modbus address Mapped to MEMOBUS/Modbus address 00FC (Hex.) (Drive Status)	Read Only	No	UNS16	00FC (Hex.) (0 - FFFF (Hex.))

■ 2110 (Hex.): Output Frequency

Note:

This object is not available for D1000 and R1000.

This object monitors the drive output frequency. The unit of this value depends on the setting of the drive parameter *o1-03 [Frequency Display Unit Selection]*.

***o1-03 = 0:* Hz**

***o1-03 = 1:* %**

100% equal *E1-04 [Maximum Output Frequency]*.

***o1-03 = 2:* min⁻¹**

Enter the number of motor poles into *E2-04 [Motor Pole Count]/E4-04 [Motor 2 Motor Poles]/E5-04 [PM Motor Pole Count]*.

o1-03 = 3: User units (Set with o1-10 [User Units Maximum Value], o1-11 [User Units Decimal Position])

Index (Hex.)	Subindex	Content	Access	PDO Mapping	Data Type	Value (Range)
2110	0	Number of entries	Read Only	No	UNS8	2
2110	1	Value	Read Only	Tx	UNS16	0 (0 - FFFF (Hex.))
2110	2	MEMOBUS/Modbus address Mapped to MEMOBUS/Modbus address 0041 (Hex.) (Output frequency)	Read Only	No	UNS16	0041 (Hex.)

■ 2120 (Hex.): Output Current

Note:

This object is not available for D1000 and R1000.

Monitors drive output current. The current value resolution is the same as drive monitor *U1-03*. For more information, refer to the Technical Manual for your drive.

Index (Hex.)	Subindex	Content	Access	PDO Mapping	Data Type	Value (Range)
2120	0	Number of entries	Read Only	No	UNS8	2
2120	1	Value	Read Only	Tx	UNS16	0 (0 - FFFF (Hex.))
2120	2	MEMOBUS/Modbus address Mapped to MEMOBUS/Modbus address 00FB (Hex.) (Output current)	Read Only	No	UNS16	00FB (Hex.)

■ 2130 (Hex.): Output Torque Reference

Note:

This object is not available for D1000 and R1000.

You can use this object to monitor the drive internal calculated torque reference. To set the torque reference from the PLC, use object 2020 (Hex.).

The availability of this object content depends on the drive control method. If the selected control mode does not support this monitor (equal to drive monitor *U1-09*), the torque reference monitor value will be 0. For more information, refer to the Technical Manual for your drive.

Index (Hex.)	Subindex	Content	Access	PDO Mapping	Data Type	Value
2130	0	Number of entries	Read Only	No	UNS8	2
2130	1	Value	Read Only	Tx	UNS16	-
2130	2	MEMOBUS/Modbus address Mapped to MEMOBUS/Modbus address 0048 (Hex.) (Output torque reference)	Read Only	No	UNS16	0048 (Hex.)

■ 2140 (Hex.): MEMOBUS/Modbus Read Response

This object contains the data of the drive MEMOBUS/Modbus register content specified in object 2040 (Hex.). Bytes 1 and 2 of subindex 1 will contain the data, bytes 3 and 4 will contain the MEMOBUS/Modbus Address that was read out.

Signature	MSB			LSB
Byte	4	3	2	1
Hex	AA		BB	
Content	MEMOBUS/Modbus address		Data	

Index (Hex.)	Subindex	Content	Access	PDO Mapping	Data Type	Value (Range)
2140	0	Number of entries	Read Only	No	UNS8	1
2140	1	MEMOBUS/Modbus read response	Read Only	Tx	UNS32	0 (0 - FFFFFFFF (Hex.))

■ 2150 (Hex.): MEMOBUS/Modbus Write Response

Bytes 1 and 2 of subindex 1 will contain the data that were written, bytes 3 and 4 will contain the MEMOBUS/Modbus Address that was written to.

Signature	MSB			LSB
Byte	4	3	2	1
Hex	AA		BB	
Content	MEMOBUS/Modbus address		Data	

Index (Hex.)	Subindex	Content	Access	PDO Mapping	Data Type	Value (Range)
2150	0	Number of entries	Read Only	No	UNS8	1
2150	1	MEMOBUS/Modbus write response	Read Only	Tx	UNS32	0 (0 - FFFFFFFF (Hex.))

■ 2151 (Hex.): Advanced MEMOBUS/Modbus Write Response

Object 2151 (Hex.) confirms register changes made by object 2051 (Hex.). Bytes 1 and 2 of subindex 1 will contain the data that were written, bytes 3 and 4 will contain the MEMOBUS/Modbus Address that was written to.

Signature	MSB			LSB
Byte	4	3	2	1
Hex	AA		BB	
Content	MEMOBUS/Modbus address		Data	

Index (Hex.)	Subindex	Content	Access	PDO Mapping	Data Type	Value (Range)
2151	0	Number of entries	Read Only	No	UNS8	1
2151	1	MEMOBUS/Modbus write response	Read Only	Tx	UNS32	0 (0 - FFFFFFFF (Hex.))

■ 2155 (Hex.): PDO Parameter Write Response

Object 2155 displays the RxPDO number and the number of errors that have occurred when writing an RxPDO, if any. This object contains the response from the drive when writing a drive parameter directly using an RxPDO. Bytes 1 and 2 contain the last RxPDO number that caused the error. Byte 3 contains the number of errors. The error counter increases when the drive flags a control data write as invalid (INVSTS2: Bit6, Control command error or local option RxPDO error).

Signature	MSB		LSB
Byte	3	2	1
Content	8 bit error counter	Last RxPDO number that caused the error	

Index (Hex.)	Subindex	Content	Access	PDO Mapping	Data Type	Value (Range)
2155	0	PDO Parameter Write Response	Read Only	Tx	UNS24	-

■ 2160 (Hex.): MEMOBUS/Modbus Unlimited Enter Command Response

Object 2160 (Hex.) contains the response from the drive when you use object 2060 (Hex.) to write an Enter command.

Response values:

OK	65766173 (Hex.)
ERR	MEMOBUS error code or SDO abort code if SDO request

Index (Hex.)	Subindex	Content	Access	PDO Mapping	Data Type	Value (Range)
2160	0	MEMOBUS/Modbus Not Limited Enter Command Response	Read Only	Tx	UNS32	0

■ 2180 (Hex.) to 21F0 (Hex.): Freely Configurable Output Objects

These objects can write selectable MEMOBUS content through fieldbus communication. You can assign any MEMOBUS address to this object. After you assign the address, you can use PDO or SDO until Power Off to write the content of this MEMOBUS address.

Subindex 2 sets the MEMOBUS address to be read. Subindex 1 reads the content.

You can link these objects to MEMOBUS/Modbus registers to determine the content.

2180 (Hex.) to 21E0 (Hex.): Freely Configurable Output Objects

Index (Hex.)	Subindex	Content	Access	PDO Mapping	Data Type	Value (Range)
2180 2190 21A0 21B0 21C0 21E0	0	Number of entries	Read Only	No	UNS8	2
2180 2190 21A0 21B0 21C0 21E0	1	Value	Read Only	Tx	UNS16	0 (0 - FFFF (Hex.))
2180	2	MEMOBUS/Modbus address of content 1 and 2	Read Write	No	UNS16	0049 (Hex.)
2190	2					004E (Hex.)
21A0 21B0 21C0 21E0	2					FFFF (Hex.)

21F0 (Hex.): Freely Configurable Output Object

Use this object to write up to two registers at the same time. To write to only one register, set the other register value to FFFF (Hex.).

Index (Hex.)	Subindex	Content	Access	PDO Mapping	Data Type	Value (Range)
21F0	0	Number of entries	Read Only	No	UNS8	2
21F0	1	Value	Read Only	Tx	UNS32	0 (0 - FFFF (Hex.))
21F0	2	MEMOBUS/Modbus address of content 1 and 2	Read Write	No	UNS32	FFFF (Hex.) + FFFF (Hex.)

■ 2200 (Hex.): Motor Speed

Note:

This object is not available for D1000 and R1000.

This object monitors the motor speed (drive parameter *U1-05 [Motor Speed]*). The value in object 2200 (Hex.) is not filtered. Setting units are determined by *o1-03 [Frequency Display Unit Selection]*.

The availability of this object content depends on the drive control method. For more information, refer to the Technical Manual for your drive.

Index (Hex.)	Subindex	Content	Access	PDO Mapping	Data Type	Value
2200	0	Number of entries	Read Only	No	UNS8	0
2200	1	Motor Speed	Read Only	Tx	UNS16	0
2200	2	MEMOBUS/Modbus write response	Read Only	No	UNS16	0044 (Hex.)

■ 2210 (Hex.): DC-Bus Voltage/Control Circuit Voltage (For U1000)

This object monitors the DC BUS voltage.

Index (Hex.)	Subindex	Content	Access	PDO Mapping	Data Type	Value (Range)
2210	0	Number of entries	Read Only	No	UNS8	2
2210	1	DC Bus Voltage Control Circuit Voltage (For U1000)	Read Only	Tx	UNS16	0
2210	2	MEMOBUS/Modbus address Mapped to MEMOBUS/Modbus address 0046 (Hex.) (DC bus voltage) Mapped to MEMOBUS/Modbus address 1081 (Hex.) (DC bus voltage) (For D1000 and R1000)	Read Only	No	UNS16	0046 (Hex.) or 1081 (Hex.)

■ 2220 (Hex.): Analog Input Monitor A1

This object displays the analog input terminal A1 level: 100% when input is 10 V.

Index (Hex.)	Subindex	Content	Access	PDO Mapping	Data Type	Value (Range)
2220	0	Number of entries	Read Only	No	UNS8	2
2220	1	Value	Read Only	Tx	UNS16	0 (0.0 - 100.0)
2220	2	MEMOBUS/Modbus address Mapped to MEMOBUS/Modbus address 004E (Hex.) (Terminal A1 Input Level)	Read Only	No	UNS16	004E (Hex.)

■ 2240 (Hex.): Analog Input Monitor A2

This object displays the analog input terminal A2 level: 100% when input is 10 V.

Index (Hex.)	Subindex	Content	Access	PDO Mapping	Data Type	Value (Range)
2240	0	Number of entries	Read Only	No	UNS8	2
2240	1	Value	Read Only	Tx	UNS16	0 (0.0 - 100.0)
2240	2	MEMOBUS/Modbus address Mapped to MEMOBUS/Modbus address 004F (Hex.) (Terminal A2 Input Level)	Read Only	No	UNS16	004F (Hex.)

■ 2260 (Hex.): Analog Input Monitor A3

Note:

This object is not available for GA500.

This object displays the analog input terminal A3 level: 100% when input is 10 V.

Index (Hex.)	Subindex	Content	Access	PDO Mapping	Data Type	Value (Range)
2260	0	Number of entries	Read Only	No	UNS8	2
2260	1	Value	Read Only	Tx	UNS16	0 (0.0 - 100.0)
2260	2	MEMOBUS/Modbus address Mapped to MEMOBUS/Modbus address 0050 (Hex.) (Terminal A3 Input Level)	Read Only	No	UNS16	0050 (Hex.)

■ 2270 (Hex.): Drive DI Input

This object displays the input terminal status.

Bit defines:

Signature	Bit	GA700	Supplementary Information
LSB	0	Terminal S1 (MFDI 1)	Refer to MEMOBUS/Modbus address 0049 (Hex.) bit 0 to bit 7 in the Technical Manual of your drive for more information.
	1	Terminal S2 (MFDI 2)	
	2	Terminal S3 (MFDI 3)	

Signature	Bit	GA700	Supplementary Information
	3	Terminal S4 (MFDI 4)	
	4	Terminal S5 (MFDI 5)	
	5	Terminal S6 (MFDI 6)	
	6	Terminal S7 (MFDI 7)	
	7	Terminal S8 (MFDI 8)	

Index (Hex.)	Subindex	Content	Access	PDO Mapping	Data Type	Value
2270	0	Number of entries	Read Only	No	UNS8	2
2270	1	Value	Read Only	Tx	UNS16	0
2270	2	MEMOBUS/Modbus address Mapped to MEMOBUS/Modbus address 0049 (Hex.) (Input Terminal Status)	Read Only	No	UNS16	0049 (Hex.)

■ 2301 (Hex.): Error Register

This register shows the fault status of the device. If there are any errors in the device, bit 0 (generic error) is set to one.

Values:

- 00 (Hex.) = No error
- 01 (Hex.) = Generic error

Index (Hex.)	Subindex	Content	Access	PDO Mapping	Data Type	Value (Range)
2301	0	Error register	Read Only	Tx	UNS8	0 (0 - 1)

■ 2318 (Hex.): Drive Information

This object contains information read from the device.

Power Rating

This object shows the drive power rating read from drive parameter *o2-04 [Drive Model (KVA) Selection]*.

Default value: 0508 (Hex.)

Drive Model Code

This object entry shows the drive model code.

Values:

- 1000 series: COSMOS
- xx700 series: String concatenated from values read from the following drive registers. 15F3 (Hex.) - 15F9 (Hex.)

Index (Hex.)	Subindex	Content	Access	PDO Mapping	Data Type	Value
2318	0	Number of entries	Read Only	No	UNS8	2
2318	1	Power Rating	Read Only	No	UNS16	0508 (Hex.)
2318	2	Drive Model Code	Read Only	No	String	

■ 251x (Hex.): Main Parameter Group A

Note:

This object is not available for A1000, D1000, R1000 and U1000.

To write a value into a parameter of the drive, you must write the value to the corresponding subindex of this object.

x: Parameter subgroup

yy: Parameter number

Note:

- If parameter number is 00, then the value for yy must be set to FF.

- If this object is written when $H5-11 = 0$ [*Comm ENTER Command Mode = ENTER Command Required*], the MEMOBUS/Modbus unlimited ENTER command will not be executed automatically. You must issue ENTER commands separately to apply changes to registers.
- Refer to the Technical Manual of your drive for more information.

To write a value into a parameter $A1-02$ [*Control Method Selection*] of the drive, you must write this value to object 2511 (Hex.), subindex 2.

Index (Hex.)	Subindex	Content	Access	PDO Mapping	Data Type
251x	0	Number of entries	Read Only	No	UNS8
251x	1 - FF	Parameter Ax-yy	Read Write	No	UNS16

■ 252x (Hex.): Main Parameter Group B

Note:

This object is not available for A1000, D1000, R1000 and U1000.

To write a value into a parameter of the drive, you must write the value to the corresponding subindex of this object.

x: Parameter subgroup

yy: Parameter number

Note:

- If parameter number is 00, then the value for yy must be set to FF.
- If this object is written when $H5-11 = 0$ [*Comm ENTER Command Mode = ENTER Command Required*], the MEMOBUS/Modbus unlimited ENTER command will not be executed automatically. You must issue ENTER commands separately to apply changes to registers.
- Refer to the Technical Manual of your drive for more information.

To write a value into a parameter $b1-02$ [*Run Command Selection 1*] of the drive, you must write this value to object 2521 (Hex.), subindex 2.

Index (Hex.)	Subindex	Content	Access	PDO Mapping	Data Type
252x	0	Number of entries	Read Only	No	UNS8
252x	1 - FF	Parameter Bx-yy	Read Write	No	UNS16

■ 253x (Hex.): Main Parameter Group C

Note:

This object is not available for A1000, D1000, R1000 and U1000.

To write a value into a parameter of the drive, you must write the value to the corresponding subindex of this object.

x: Parameter subgroup

yy: Parameter number

Note:

- If parameter number is 00, then the value for yy must be set to FF.
- If this object is written when $H5-11 = 0$ [*Comm ENTER Command Mode = ENTER Command Required*], the MEMOBUS/Modbus unlimited ENTER command will not be executed automatically. You must issue ENTER commands separately to apply changes to registers.
- Refer to the Technical Manual of your drive for more information.

To write a value into a parameter $C1-02$ [*Deceleration Time 1*] of the drive, you must write this value to object 2531 (Hex.), sub-index 2.

Index (Hex.)	Subindex	Content	Access	PDO Mapping	Data Type
253x	0	Number of entries	Read Only	No	UNS8
253x	1 - FF	Parameter Cx-yy	Read Write	No	UNS16

■ 254x (Hex.): Main Parameter Group D

Note:

This object is not available for A1000, D1000, R1000 and U1000.

To write a value into a parameter of the drive, you must write the value to the corresponding subindex of this object.

x: Parameter subgroup

yy: Parameter number

Note:

- If parameter number is 00, then the value for yy must be set to FF.
- If this object is written when $H5-11 = 0$ [*Comm ENTER Command Mode = ENTER Command Required*], the MEMOBUS/Modbus unlimited ENTER command will not be executed automatically. You must issue ENTER commands separately to apply changes to registers.
- Refer to the Technical Manual of your drive for more information.

To write a value into a parameter $d1-02$ [*Reference 2*] of the AC drive, you must write this value to object 2541 (Hex.), subindex 2.

Index (Hex.)	Subindex	Content	Access	PDO Mapping	Data Type
254x	0	Number of entries	Read Only	No	UNS8
254x	1 - FF	Parameter Dx-yy	Read Write	No	UNS16

■ 255x (Hex.): Main Parameter Group E

Note:

This object is not available for A1000, D1000, R1000 and U1000.

To write a value into a parameter of the drive, you must write the value to the corresponding subindex of this object.

x: Parameter subgroup

yy: Parameter number

Note:

- If parameter number is 00, then the value for yy must be set to FF.
- If this object is written when $H5-11 = 0$ [*Comm ENTER Command Mode = ENTER Command Required*], the MEMOBUS/Modbus unlimited ENTER command will not be executed automatically. You must issue ENTER commands separately to apply changes to registers.
- Refer to the Technical Manual of your drive for more information.

To write a value into a parameter $E1-01$ [*Input AC Supply Voltage*] of the drive, you must write this value to object 2551 (Hex.), subindex 1.

Index (Hex.)	Subindex	Content	Access	PDO Mapping	Data Type
255x	0	Number of entries	Read Only	No	UNS8
255x	1 - FF	Parameter Ex-yy	Read Write	No	UNS16

■ 256x (Hex.): Main Parameter Group F

Note:

This object is not available for A1000, D1000, R1000 and U1000.

To write a value into a parameter of the drive, you must write the value to the corresponding subindex of this object.

x: Parameter subgroup

yy: Parameter number

Note:

- If parameter number is 00, then the value for yy must be set to FF.
- If this object is written when $H5-11 = 0$ [*Comm ENTER Command Mode = ENTER Command Required*], the MEMOBUS/Modbus unlimited ENTER command will not be executed automatically. You must issue ENTER commands separately to apply changes to registers.

- Refer to the Technical Manual of your drive for more information.

To write a value into a parameter *F1-02 [Encoder Signal Loss Detect Sel]* of the drive, you must write this value to object 2561 (Hex.), subindex 2.

Index (Hex.)	Subindex	Content	Access	PDO Mapping	Data Type
256x	0	Number of entries	Read Only	No	UNS8
256x	1 - FF	Parameter Fx-yy	Read Write	No	UNS16

■ 258x (Hex.): Main Parameter Group H

Note:

This object is not available for A1000, D1000, R1000 and U1000.

To write a value into a parameter of the drive, you must write the value to the corresponding subindex of this object.

x: Parameter subgroup

yy: Parameter number

Note:

- If parameter number is 00, then the value for yy must be set to FF.
- If this object is written when *H5-11 = 0 [Comm ENTER Command Mode = ENTER Command Required]*, the MEMOBUS/Modbus unlimited ENTER command will not be executed automatically. You must issue ENTER commands separately to apply changes to registers.
- Refer to the Technical Manual of your drive for more information.

To write a value into a parameter *H1-02 [Terminal S2 Function Selection]* of the drive, you must write this value to object 2581 (Hex.), subindex 2.

Index (Hex.)	Subindex	Content	Access	PDO Mapping	Data Type
258x	0	Number of entries	Read Only	No	UNS8
258x	1 - FF	Parameter Hx-yy	Read Write	No	UNS16

■ 25Cx (Hex.): Main Parameter Group L

Note:

This object is not available for A1000, D1000, R1000 and U1000.

To write a value into a parameter of the drive, you must write the value to the corresponding subindex of this object.

x: Parameter subgroup

yy: Parameter number

Note:

- If parameter number is 00, then the value for yy must be set to FF.
- If this object is written when *H5-11 = 0 [Comm ENTER Command Mode = ENTER Command Required]*, the MEMOBUS/Modbus unlimited ENTER command will not be executed automatically. You must issue ENTER commands separately to apply changes to registers.
- Refer to the Technical Manual of your drive for more information.

To write a value into a parameter *L1-02 [Motor Overload Protection Time]* of the drive, you must write this value to object 25C1 (Hex.), subindex 2.

Index (Hex.)	Subindex	Content	Access	PDO Mapping	Data Type
25Cx	0	Number of entries	Read Only	No	UNS8
25Cx	1 - FF	Parameter Lx-yy	Read Write	No	UNS16

■ 25Ex (Hex.): Main Parameter Group N

Note:

This object is not available for A1000, D1000, R1000 and U1000.

To write a value into a parameter of the drive, you must write the value to the corresponding subindex of this object.

x: Parameter subgroup

yy: Parameter number

Note:

- If parameter number is 00, then the value for yy must be set to FF.
- If this object is written when $H5-11 = 0$ [*Comm ENTER Command Mode = ENTER Command Required*], the MEMOBUS/Modbus unlimited ENTER command will not be executed automatically. You must issue ENTER commands separately to apply changes to registers.
- Refer to the Technical Manual of your drive for more information.

To write a value into a parameter $n1-02$ [*Hunting Prevention Gain Setting*] of the drive, you must write this value to object 25E1 (Hex.), subindex 2.

Index (Hex.)	Subindex	Content	Access	PDO Mapping	Data Type
25Ex	0	Number of entries	Read Only	No	UNS8
25Ex	1 - FF	Parameter Nx-yy	Read Write	No	UNS16

■ 25Fx (Hex.): Main Parameter Group O

Note:

This object is not available for A1000, D1000, R1000 and U1000.

To write a value into a parameter of the drive, you must write the value to the corresponding subindex of this object.

x: Parameter subgroup

yy: Parameter number

Note:

- If parameter number is 00, then the value for yy must be set to FF.
- If this object is written when $H5-11 = 0$ [*Comm ENTER Command Mode = ENTER Command Required*], the MEMOBUS/Modbus unlimited ENTER command will not be executed automatically. You must issue ENTER commands separately to apply changes to registers.
- Refer to the Technical Manual of your drive for more information.

To write a value into a parameter $o1-02$ [*Monitor Selection at Power-up*] of the drive, you must write this value to object 25F1 (Hex.), subindex 2.

Index (Hex.)	Subindex	Content	Access	PDO Mapping	Data Type
25Fx	0	Number of entries	Read Only	No	UNS8
25Fx	1 - FF	Parameter Ox-yy	Read Write	No	UNS16

■ 261x (Hex.): Main Parameter Group Q

Note:

This object is not available for A1000, D1000, R1000 and U1000.

To write a value into a parameter of the drive, you must write the value to the corresponding subindex of this object.

x: Parameter subgroup

yy: Parameter number

Note:

- If parameter number is 00, then the value for yy must be set to FF.
- If this object is written when $H5-11 = 0$ [*Comm ENTER Command Mode = ENTER Command Required*], the MEMOBUS/Modbus unlimited ENTER command will not be executed automatically. You must issue ENTER commands separately to apply changes to registers.
- Refer to the Technical Manual of your drive for more information.

To write a value into a parameter $Q1-02$ [*Custom Parameter 2*] of the drive, you must write this value to object 2611 (Hex.), subindex 2.

Index (Hex.)	Subindex	Content	Access	PDO Mapping	Data Type
261x	0	Number of entries	Read Only	No	UNS8
261x	1 - FF	Parameter Qx-yy	Read Write	No	UNS16

■ 262x (Hex.): Main Parameter Group R

Note:

This object is not available for A1000, D1000, R1000 and U1000.

To write a value into a parameter of the drive, you must write the value to the corresponding subindex of this object.

x: Parameter subgroup

yy: Parameter number

Note:

- If parameter number is 00, then the value for yy must be set to FF.
- If this object is written when $H5-11 = 0$ [Comm ENTER Command Mode = ENTER Command Required], the MEMOBUS/Modbus unlimited ENTER command will not be executed automatically. You must issue ENTER commands separately to apply changes to registers.
- Refer to the Technical Manual of your drive for more information.

To write a value into a parameter $R1-02$ [Connection 1 Data (low word)] of the drive, you must write this value to object 2621 (Hex.), subindex 2.

Index (Hex.)	Subindex	Content	Access	PDO Mapping	Data Type
262x	0	Number of entries	Read Only	No	UNS8
262x	1 - FF	Parameter Rx-yy	Read Write	No	UNS16

■ 264x (Hex.): Main Parameter Group T

Note:

This object is not available for A1000, D1000, R1000 and U1000.

To write a value into a parameter of the drive, you must write the value to the corresponding subindex of this object.

x: Parameter subgroup

yy: Parameter number

Note:

- If parameter number is 00, then the value for yy must be set to FF.
- If this object is written when $H5-11 = 0$ [Comm ENTER Command Mode = ENTER Command Required], the MEMOBUS/Modbus unlimited ENTER command will not be executed automatically. You must issue ENTER commands separately to apply changes to registers.
- Refer to the Technical Manual of your drive for more information.

To write a value into a parameter $T1-02$ [Motor Rated Power] of the drive, you must write this value to object 2641 (Hex.), subindex 2.

Index (Hex.)	Subindex	Content	Access	PDO Mapping	Data Type
264x	0	Number of entries	Read Only	No	UNS8
264x	1 - FF	Parameter Tx-yy	Read Write	No	UNS16

■ 265x (Hex.): Main Parameter Group U

Note:

This object is not available for A1000, D1000, R1000 and U1000.

This object is read only. To read the monitor value of the drive, you must read the subindex of this object as follows.

x: Parameter subgroup

yy: Parameter number

Note:

- If parameter number is 00, then the value for yy must be set to FF.
- Refer to the Technical Manual of your drive for more information.

To read a value from a monitor *U1-02 [Output Frequency]* of the drive, you must read the value of object 2651 (Hex.), subindex 2.

Index (Hex.)	Subindex	Content	Access	PDO Mapping	Data Type
265x	0	Number of entries	Read Only	No	UNS8
265x	1 - FF	Parameter Ux-yy	Read Only	Tx	UNS16

■ 2E00 (Hex.): Gateway Mode Communication Settings

Note:

This object does not work on the drives which *F6-16 [Gateway Mode]* is not available. Only usable when *F6-16 = 1 to 4 [Enabled: 1 to 4 Slave Drives]*.

This object should be used when 2E01 (Hex.) to 2E04 (Hex.) have to be available.

Index (Hex.)	Subindex	Content	Access	PDO Mapping	Data Type	Value	Drive MEMOBUS/ Modbus Registers (Hex.) *1
2E00	0	Value	Read Write	Rx/Tx	UNS16	0	15C5

*1 Refer to the corresponding MEMOBUS/Modbus register in the Technical Manual for your drive.

■ 2E01 (Hex.) to 2E04 (Hex.): Gateway Slave Drive Operation

Note:

This object does not work on the drives which *F6-16 [Gateway Mode]* is not available. Only usable when *F6-16 = 1 to 4 [Enabled: 1 to 4 Slave Drives]*.

Run command and frequency reference on the gateway mode should be set to this object.

Index (Hex.)	Subindex	Description	Access	PDO Mapping	Data Type	Value	Drive MEMOBUS/ Modbus Registers (Hex.) *1
2E01	0	Number of entries	Read Only	No	UNS8	2	-
	1	Run Command (Drive1)	Read Write	Rx/Tx	UNS16	0	15C6
	2	Frequency Reference (Drive1)	Read Write	Rx/Tx	UNS16	0	15C7
2E02	0	Number of entries	Read Only	No	UNS8	2	-
	1	Run Command (Drive2)	Read Write	Rx/Tx	UNS16	0	15C8
	2	Frequency Reference (Drive2)	Read Write	Rx/Tx	UNS16	0	15C9
2E03	0	Number of entries	Read Only	No	UNS8	2	-
	1	Run Command (Drive3)	Read Write	Rx/Tx	UNS16	0	15CA
	2	Frequency Reference (Drive3)	Read Write	Rx/Tx	UNS16	0	15CB
2E04	0	Number of entries	Read Only	No	UNS8	2	-
	1	Run Command (Drive4)	Read Write	Rx/Tx	UNS16	0	15CC
	2	Frequency Reference (Drive4)	Read Write	Rx/Tx	UNS16	0	15CD

*1 Refer to the corresponding MEMOBUS/Modbus register in the Technical Manual for your drive.

■ 2EFF (Hex.): Gateway MEMOBUS/Modbus Read/Write Request

Note:

This object does not work on the drives which *F6-16 [Gateway Mode]* is not available. Only usable when *F6-16 = 1 to 4 [Enabled:1 to 4 Slave Drives]*.

The MEMOBUS read or write request on the gateway mode should be set to this object.

Index (Hex.)	Subindex	Description	Access	PDO Mapping	Data Type	Value	Drive MEMOBUS/Modbus Registers (Hex.) */
2EFF	0	Number of entries	Read Only	No	UNS8	3	-
	1	Slave Address for Reg. Access + Read/Write	Read Write	Rx/Tx	UNS16	0	15CE
	2	Register number	Read Write	Rx/Tx	UNS16	0	15CF
	3	Write	Read Write	Rx/Tx	UNS16	0	15D0

*1 Refer to the corresponding MEMOBUS/Modbus register in the Technical Manual for your drive.

■ 2F01 (Hex.) to 2F04 (Hex.): Gateway Slave Drive Status

Note:

This object does not work on the drives which *F6-16 [Gateway Mode]* is not available. Only usable when *F6-16 = 1 to 4 [Enabled:1 to 4 Slave Drives]*.

Drive status, output frequency, or frequency reference on the gateway mode are set to this object.

Index (Hex.)	Subindex	Content	Access	PDO Mapping	Data Type	Value	Drive MEMOBUS/Modbus Registers (Hex.) */
2F01	0	Number of entries	Read Only	No	UNS8	2	-
	1	Drive Status (Drive 1)	Read Only	Tx	UNS16	-	15E7
	2	Output frequency or frequency reference (Drive 1)	Read Only	Tx	UNS16	-	15E8
2F02	0	Number of entries	Read Only	No	UNS8	2	-
	1	Drive Status (Drive 2)	Read Only	Tx	UNS16	-	15E9
	2	Output frequency or frequency reference (Drive 2)	Read Only	Tx	UNS16	-	15EA
2F03	0	Number of entries	Read Only	No	UNS8	2	-
	1	Drive Status (Drive 3)	Read Only	Tx	UNS16	-	15EB
	2	Output frequency or frequency reference (Drive 3)	Read Only	Tx	UNS16	-	15EC
2F04	0	Number of entries	Read Only	No	UNS8	2	-
	1	Drive Status (Drive 4)	Read Only	Tx	UNS16	-	15ED
	2	Output frequency or frequency reference (Drive 4)	Read Only	Tx	UNS16	-	15EE

*1 Refer to the corresponding MEMOBUS register in the technical manual for your drive.

■ 2FFF (Hex.): Gateway MEMOBUS/Modbus Read/Write Response

Note:

This object does not work on the drives which *F6-16 [Gateway Mode]* is not available. Only usable when *F6-16 = 1 to 4 [Enabled:1 to 4 Slave Drives]*.

The MEMOBUS read or write request on the gateway mode should be set to this object.

Index (Hex.)	Subindex	Description	Access	PDO Mapping	Data Type	Value	Drive MEMOBUS/Modbus Registers (Hex.) */
2FFF	0	Number of entries	Read Only	No	UNS8	3	-

Index (Hex.)	Subindex	Description	Access	PDO Mapping	Data Type	Value	Drive Drive MEMOBUS/ Modbus Registers (Hex.) */
	1	Slave Address for Reg. Access + During MEMOBUS process & ErrCode	Read Only	Tx	UNS16	-	15EF
	2	Register number	Read Only	Tx	UNS16	-	15F0
	3	Data	Read Only	Tx	UNS16	-	15F1

*1 Refer to the corresponding MEMOBUS/Modbus register in the Technical Manual for your drive.

■ 4001 (Hex.): Option Info + Status Record

This object provides general information of option system firmware parts and internal system states.

OptBootFwRev

This object entry shows the drive model code.

Values:

- AA = Major revision
- BB = Minor revision
- CC = Build

OptAppFwRev

Application firmware revision in flash.

Values:

- AA = Major revision
- BB = Minor revision
- CC = Build

OptRunTimeMS

Total running time in milliseconds of option system since power-up.

NOISystem: iSysErrorBits

NOI System active error bits.

NOISystem: iSysErrorBitsLatched

NOI System latched (All errors that have occurred since start-up) error bits.

Index (Hex.)	Subindex	Content	Access	PDO Mapping	Data Type	Value (Range)
4001	0	Number of entries	Read Only	No	UNS8	5
4001	1	OptBootFwRev	Read Only	No	UNS32	00AABBCC
4001	2	OptAppFwRev	Read Only	No	UNS32	00AABBCC
4001	3	OptRunTimeMS	Read Only	No	UNS32	0 (0 - FFFFFFFF (Hex.))
4001	4	NOISystem: iSysErrorBits	Read Only	No	UNS16	0 (0 - FFFF (Hex.))
4001	5	NOISystem: iSysErrorBitsLatched	Read Only	No	UNS16	0 (0 - FFFF (Hex.))

■ 4010 (Hex.): Store Parameters

Write “save” to this object to save the EtherCAT Option settings in the non-volatile memory.

Signature	MSB			LSB
ASCII	e	v	a	s
Hex	65	76	61	73

Actions: Will issue Limited Enter command. Writes data into the EEPROM of the drive and enables the data in RAM at the same time. Parameter changes will stay even if you cycle the power supply.

Note:

You can write the EEPROM to the drive a maximum of 100,000 times. Do not frequently execute the Enter command that is written to EEPROM.

Refer to [1010 \(Hex.\): Store Parameters on page 25](#) for information.

Index (Hex.)	Subindex	Content	Access	PDO Mapping	Data Type	Value
4010	0	Store parameters	Write Only	No	UNS32	01 (Hex.) (Save on command)

■ 4011 (Hex.): Restore Default Parameters

Write “load” to this object to restore the EtherCAT Option default settings.

Signature	MSB			LSB
ASCII	d	a	o	l
Hex	64	61	6F	6C

Actions: The option will write value = 2220 to *A1-03 [Initialize Parameters]* (INVR:0103 (Hex)) together with an EEPROM ENTER command.

Note:

You can write the EEPROM to the drive a maximum of 100,000 times. Do not frequently execute the Enter command that is written to EEPROM.

Refer to [1011 \(Hex.\): Restore Default Parameters on page 26](#) for information.

Index (Hex.)	Subindex	Content	Access	PDO Mapping	Data Type	Value
4011	0	Restore Default Parameters	Write Only	No	UNS32	01 (Hex.) (Restore on command)

◆ Converter Specific Profile Objects

These objects are used for the converter.

■ 5000 (Hex.): Regenerated Energy

Note:

This object is available for D1000, R1000, and U1000.

Energy regenerated by the converter.

0: Regenerated Energy

Write 0 to subindex 0 to clear this object as well as object 5004 (Hex.) (Consumed Energy).

Index (Hex.)	Subindex	Description	Access	PDO Mapping	Data Type	Value (Range)
5000	0	Number of entries	Read Write	No	UNS8	3 (0, 3)
5000	1	Regenerated Energy (GWh) Mapped to MEMOBUS/Modbus address 0823 (Hex.) (Regenerated Energy GWh)	Read Only	Tx	UNS16	0 (0 - FFFF (Hex.))
5000	2	Regenerated Energy (MWh) Mapped to MEMOBUS/Modbus address 0824 (Hex.) (Regenerated Energy MWh)	Read Only	Tx	UNS16	0 (0 - FFFF (Hex.))
5000	3	Regenerated Energy (kWh) Mapped to MEMOBUS/Modbus address 0825 (Hex.) (Regenerated Energy kWh)	Read Only	Tx	UNS16	0 (0 - FFFF (Hex.))

■ 5001 (Hex.): Input Voltage

Note:

This object is available for D1000, R1000, and U1000.

Sets the converter input voltage.

Index (Hex.)	Subindex	Content	Access	PDO Mapping	Data Type	Value (Range)
5001	-	Input Voltage Mapped to MEMOBUS/Modbus address 1083 (Hex.) (Power Supply Voltage)	Read Only	Tx	UNS16	- (0 - FFFF (Hex.))

■ 5002 (Hex.): Current Limit

Note:

This object is available for D1000 and R1000.

This object can be used to set the positive and negative current limit.

This object sets the Current Limit Selection in units of rated current for 0.1%.

Positive current: motoring current

Negative current: regenerative current

Index (Hex.)	Subindex	Description	Access	PDO Mapping	Data Type	Value (Range)
5002	0	Number of entries	Read Only	No	UNS8	2
5002	1	Positive current limit Mapped to MEMOBUS/Modbus address 0004 (Hex.) (Active Current Limit (Positive))	Read Write	Rx/Tx	UNS16	0 (0.0 - 100.0)
5002	2	Negative current limit Mapped to MEMOBUS/Modbus address 000E (Hex.) (Active Current Limit (Negative))	Read Write	Rx/Tx	UNS16	0 (0.0 - 100.0)

■ 5003 (Hex.): AC Power

Note:

This object is available for D1000 and R1000.

This object shows the AC power from the converter.

Index (Hex.)	Subindex	Description	Access	PDO Mapping	Data Type	Value (Range)
5003	-	AC Power Mapped to MEMOBUS/Modbus address 1086 (Hex.) (Power Supply Side Power)	Read Only	Tx	UNS16	0 (0 - FFFF (Hex.))

■ 5004 (Hex.): Consumed Energy

Note:

This object is available for D1000 and R1000.

Energy consumed by the converter.

0: Consumed Energy

Write 0 to subindex 0 to clear this object as well as object 5000 (Hex.) (Regenerated Energy).

Index (Hex.)	Subindex	Description	Access	PDO Mapping	Data Type	Value (Range)
5004	0	Number of entries	Read Write	No	UNS8	3 (0, 3)
5004	1	Consumed Energy (GWh) Mapped to MEMOBUS/Modbus address 0820 (Hex.) (Regenerated Energy GWh)	Read Only	Tx	UNS16	0 (0 - FFFF (Hex.))
5004	2	Consumed Energy (MWh) Mapped to MEMOBUS/Modbus address 0821 (Hex.) (Regenerated Energy MWh)	Read Only	Tx	UNS16	0 (0 - FFFF (Hex.))
5004	3	Consumed Energy (kWh) Mapped to MEMOBUS/Modbus address 0822 (Hex.) (Regenerated Energy kWh)	Read Only	Tx	UNS16	0 (0 - FFFF (Hex.))

■ 5005 (Hex.): DC Bus Voltage Reference

Note:

This object is available for D1000 and R1000.

This object can be used to read out the DC bus voltage reference.

Index (Hex.)	Subindex	Description	Access	PDO Mapping	Data Type	Value (Range)
5005	-	DC Bus Voltage Reference Mapped to MEMOBUS/Modbus address 000D (Hex.) (DC Bus Voltage Reference)	Read Write	Rx/Tx	UNS16	0 (0 - FFFF (Hex.))

◆ CANopen DSP402 Controlword/Statusword

This section describes how to use controlword/statusword to control the drive and how to access drive parameters.

■ CANopen DSP402 Controlword

Table 8.6 Controlword

Bit Number	Controlword	Description	Ref.
0	Switch on	This bit controls the DSP402 state machine.	Table 8.10
1	Enable voltage	This bit controls the DSP402 state machine.	Table 8.10
2	Quick stop	This bit controls the DSP402 state machine.	Table 8.10
3	Enable operation	This bit controls the DSP402 state machine.	Table 8.10
4	Operation mode specific	-	Table 8.8
5	Operation mode specific	-	Table 8.8
6	Operation mode specific	-	Table 8.8
7	Fault reset	This bit controls the DSP402 state machine.	Table 8.10
8	Halt	Not implemented	-
9	Operation mode specific	-	Table 8.8
10	Reserved	Not used	-
11	Manufacturer specific	N/A	-
12	Manufacturer specific	N/A	-
13	Manufacturer specific	N/A	-
14	Manufacturer specific	N/A	-
15	Manufacturer specific	N/A	-

■ CANopen DSP402 Statusword

Table 8.7 Statusword

Bit Number	Statusword	Description	Ref.
0	Ready to switch on	This bit controls the DS402 state machine.	Table 8.11
1	Switched on	This bit controls the DS402 state machine.	Table 8.11
2	Operation enabled	This bit controls the DS402 state machine.	Table 8.11
3	Fault	This bit controls the DS402 state machine.	Table 8.11
4	Voltage enabled	This bit controls the DS402 state machine.	Table 8.11
5	Quick stop	This bit controls the DS402 state machine.	Table 8.11
6	Switch on disabled	This bit controls the DS402 state machine.	Table 8.11
7	Warning	1: INVR: 00FC (Hex) & 0040 (Hex) 2: !(INVR: 00FC (Hex) & 0040 (Hex))	-
8	Manufacturer specific	N/A	-
9	Remote	1: Online-DRV:INVSTS2 & 0003 (Hex) != 0 (INV uses NET cmd or ref) 0: Online-DRV:INVSTS2 & 0003 (Hex) = 0 (INV does not use NET cmd or ref)	-
10	Target reached (Op mode spec)	-	Table 8.9
11	Internal limit active	0: Always, not implemented	-
12	Operation mode specific	-	Table 8.9
13	Operation mode specific	-	Table 8.9
14	Manufacturer specific	N/A	-
15	Manufacturer specific	N/A	-

■ Controlword Operation Mode Specific Bits in Velocity Mode

Table 8.8 Controlword Operation Mode Specific Bits in Velocity Mode

Bit Number	Controlword	Description
4	rfg enable	0: Online-DRV:OPTSTS2#0002 (Hex) = 0 (Clear NetRef bit) 1: Online-DRV:OPTSTS2#0002 (Hex) = 1 (Clear NetRef bit)
5	rfg unlock	0: Discard any new NET set-point 1: Use NET set-point
6	rfg use ref	0: Force NET set-point to zero 1: Use NET set-point
9	Not implemented	Not implemented

■ Statusword Operation Mode Specific Bits in Velocity Mode

Table 8.9 Statusword Operation Mode Specific Bits in Velocity Mode

Bit Number	Statusword	Description
(10)	Target reached	0: !(INVR:00FC (Hex) & 0010 (Hex)) 1: INVR:00FC (Hex) & 0010 (Hex)
12	Reserved	0: Always, not applicable in Velocity Mode
13	Reserved	0: Always, not applicable in Velocity Mode

■ Controlword State Transition Bits

Table 8.10 Controlword State Transition Bits

DSP402 Command	Controlword Bits					Controlword Example (Hex.)	Transitions
	Bit 7	Bit 3	Bit 2	Bit 1	Bit 0		
0: Shutdown	0	X	1	1	0	06	2, 6, 8
1: Switch on	0	0	1	1	1	07	3
2: Switch on + enable operation	0	1	1	1	1	0F	3 + 4 * / *2
3: Disable voltage	0	X	X	0	X	00	7, 9, 10, 12
4: Quick stop	0	X	0	1	X	02	7, 10, 11
5: Disable Operation	0	0	1	1	1	07	5
6: Enable Operation	0	1	1	1	1	0F	4, 16
7: Fault Reset	0 → 1	X	X	X	X	00	15

*1 Automatic transition to Enable operation state after executing Switch on state functionality.

*2 If the option does not have the NetCtrl command (Online-DRV#INVSTS2&0002 (Hex)) it will not process any command orders against the drive.

■ Statusword State Transition Bits

After a change in the control word (remote control) as specified in [Table 8.10](#), the node state will change and the state result will be identified in the status word as specified in [Table 8.11](#).

Table 8.11 Statusword State Transition Bits

DSP402 Command	Statusword Bits						Statusword Example (Hex.)
	Bit 6	Bit 5	Bit 3	Bit 2	Bit 1	Bit 0	
1: Not ready to switch on	0	X	0	0	0	0	00
2: Switch on disabled	1	X	0	0	0	0	20
3: Ready to switch on	0	1	0	0	0	1	11
4: Switch on	0	1	0	0	1	1	13
5: Operation enabled	0	1	0	1	1	1	17
6: Quick stop active	0	0	0	1	1	1	07
7: Fault reaction active	0	X	1	1	1	1	0F
8: Fault	0	X	1	0	0	0	08

■ CANopen DSP402 State Transition Definition

The YASKAWA EtherCAT option has the state transitions and states as shown in Figure 8.1. To accept frequency and operation commands, the module must be in the Operation Enable state. Table 8.12 describes the events that are necessary to change between different states. The control word from the bus triggers most of these events, but others are internally triggered.

■ CANopen DSP402 State Diagram

The EtherCAT option is always in one of the states shown below. The events that trigger transitions between the states are either sent with the control word or triggered by an internal action. All the possible events and the corresponding transition numbers are listed in Table 8.12.

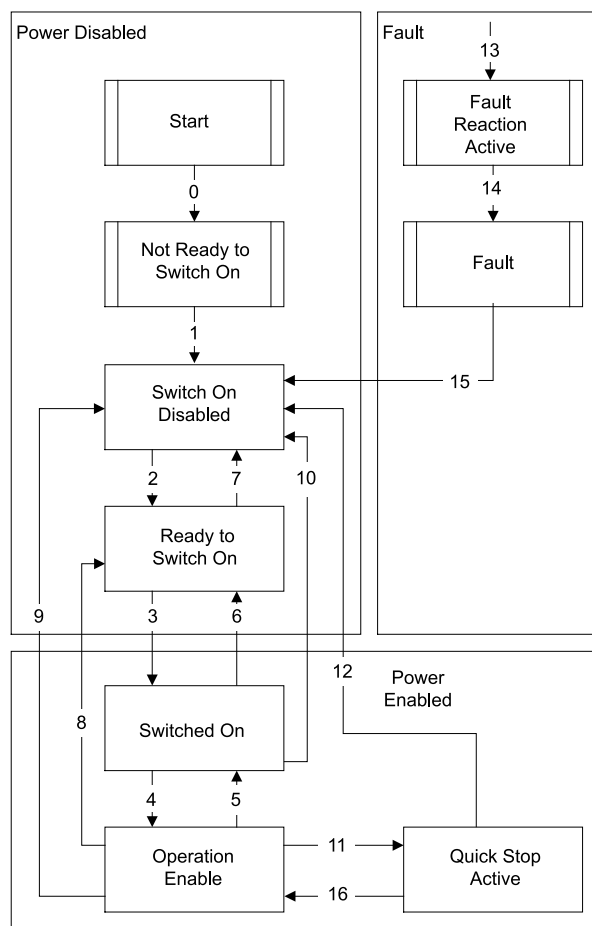

Transition 16 is only available while the drive is doing a Quick Stop. When completed, the transition will automatically be processed.

Figure 8.1 DSP402 State Diagram

■ CANopen DSP402 Event Description

The state transitions in Table 8.12 are available in the CANopen DSP402 drive profile. Transitions 0 and 1 are triggered at start-up. After all start-up tests are complete, the module will be in state 3. You can trigger some commands from more than one place. For example, you can trigger the fault reset command from the bus with the control word or from the application drive.

Table 8.12 Event Description

State Transition Number	Transition Name	DSP402 Event
0	Startup → Not Ready To Switch On	Reset
1	Not ready to switch on → Switch on disabled	Self test and init successful
2	Switch on disabled → Ready to switch on	Shutdown command received
3	Ready to switch on → Switch on disabled	Switch on command received
4	Switched on → Operation enabled	Enable operation command received

State Transition Number	Transition Name	DSP402 Event
5	Operation enabled → Switched on	Disable operation command received
6	Switch on → Ready to switch on	Shutdown command received
7	Ready to switch on → Switch on disabled	Disable voltage command received or Quickstop command received
8	Operation enabled → Ready to switch on	Shutdown command received
9	Operation enabled → Switch on disabled	Disable voltage command received
10	Switched on → Switch on disabled	Disable voltage command received or Quickstop command received
11	Operation enabled → Quick stop active	Quickstop command received
12	Quick stop active → Switch on disabled	Quickstop command completed or Disable voltage command received
13	All states → Fault reaction active	Fatal fault has occurred in the drive
14	Fault reaction active → Fault	The fault action is completed
15	Fault → Switch on disabled	Fault reset command received
16	Quick stop active → Operation enabled	Enable operation command received

◆ Drives and Motion Profile Objects (DSP 402) Details

The drive supports the Drive and Motion Profile DSP 402 Velocity Mode.

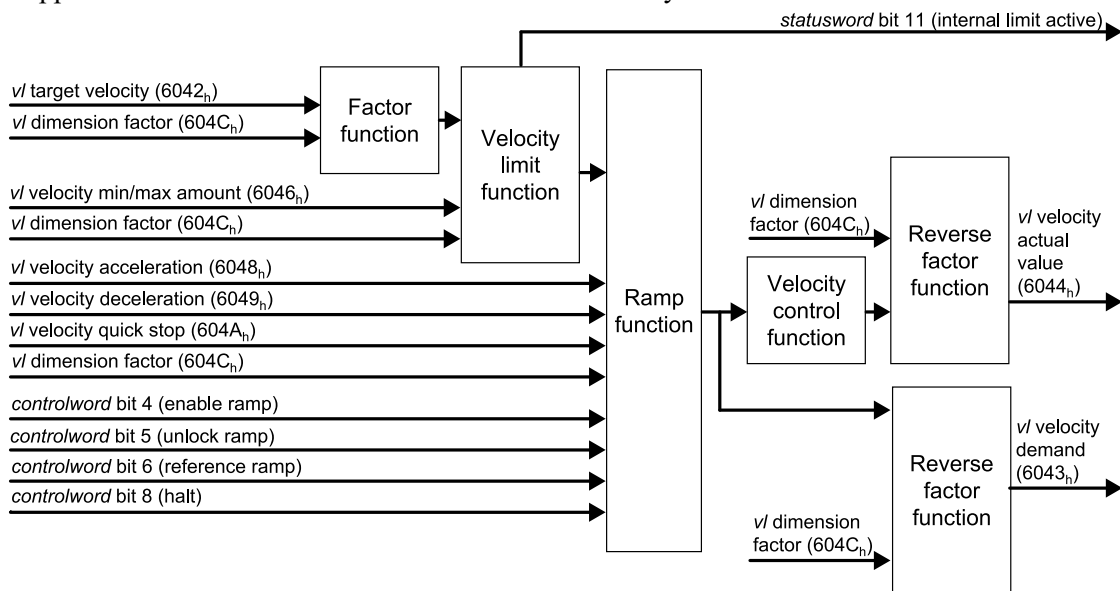

Figure 8.2 Velocity mode with all objects

■ 6040 (Hex.): Controlword

Note:

This object is not available for D1000 and R1000.

This object sets the device to different states.

Index (Hex.)	Subindex	Content	Access	PDO Mapping	Data Type	Value
6040	0	Controlword	Read Write	Rx/Tx	UNS16	-

■ 6041 (Hex.): Statusword

Note:

This object is not available for D1000 and R1000.

This object shows different states of the device.

Index (Hex.)	Subindex	Content	Access	PDO Mapping	Data Type	Value
6041	0	Statusword	Read Only	Tx	UNS16	-

■ 6042 (Hex.): v1 Target Velocity

Note:

This object is not available for D1000 and R1000.

This object sets the drive internal speed reference. It is internally multiplied with the 604C (Hex.) v1 dimension factor. The drive works internally with absolute values of v1 target velocity only. Negative values written to this object set the internal reverse Run command.

Index (Hex.)	Subindex	Description	Access	PDO Mapping	Data Type	Value (Range)
6042	0	v1 Target Velocity Mapped to MEMOBUS/Modbus address 0002 (Hex.) (Reference frequency in min ⁻¹)	Read Write	Rx/Tx	S16	0 (-32768 - 32767)

■ 6043 (Hex.): v1 Velocity Demand

Note:

This object is not available for D1000 and R1000.

This object shows the output frequency (rpm) of the drive to the motor. The drive works internally with absolute values of v1 target velocity only. Negative values read from this object depend on the internal reverse Run command.

Index (Hex.)	Subindex	Content	Access	PDO Mapping	Data Type	Value (Range)
6043	0	v1 Velocity Demand Mapped to MEMOBUS/Modbus address 0041 (Hex.) (Output frequency in min ⁻¹)	Read Only	Tx	S16	0 (-32768 - 32767)

■ 6044 (Hex.): v1 Velocity Control Effort/Actual Value

Note:

This object is not available for D1000 and R1000.

This object shows the output frequency (rpm) of the drive to the motor. The drive works internally with absolute values of v1 target velocity only. Negative values read from this object depend on the internal reverse Run command.

Index (Hex.)	Subindex	Content	Access	PDO Mapping	Data Type	Value (Range)
6044	0	v1 Velocity Control Effort/Actual Value Mapped to: <ul style="list-style-type: none"> • If A1-02 = 0 or 5 [Control Method Selection = V/f Control or PM Open Loop Vector], MEMOBUS/Modbus address 0041 (Hex.) (Output frequency in min⁻¹) • else MEMOBUS/Modbus address 00AC (Hex.) (Motor speed in min⁻¹) 	Read Only	Tx	S16	0 (-32768 - 32767)

■ 6046 (Hex.): v1 Velocity Min Max Amount

Note:

This object is not available for D1000 and R1000.

This object sets the minimum and maximum allowable speed of the drive. Subindices 1 and 2 are mapped to d2-02 [Frequency Reference Lower Limit] and d2-01 [Frequency Reference Upper Limit], respectively. The drive does an internal calculation on the value entered into this object. The formula to determine the d2-01 or d2-02 value is as shown here:

$$d2-02 = \frac{6046:1 \text{ (Hex.)} \times E2-04 \text{ (Motor Poles)}}{120 \times E1-04 \text{ (Max. Motor Speed (Hz))}}$$

Index (Hex.)	Subindex	Content	Access	PDO Mapping	Data Type	Value (Range)
6046	1	v1 Velocity Min Amount; in rpm Mapped to MEMOBUS/Modbus address 028A (Hex.)/ d2-02 [Frequency Reference Lower Limit]	Read Write	Rx/Tx	UNS32	0 (0 - 2 ³² -1)
6046	2	v1 Velocity Max Amount; in rpm Mapped to MEMOBUS/Modbus address 0289 (Hex.)/ d2-01 [Frequency Reference Upper Limit]	Read Write	Rx/Tx	UNS32	0 (0 - 2 ³² -1)

■ 6048 (Hex.): vl Velocity Acceleration

Note:

This object is not available for D1000 and R1000.

This object sets the acceleration ramp of the drive. Subindices 1 and 2 are mapped to *C1-01 [Acceleration Time I]*. The drive does an internal calculation on the value entered into this object. The formula to determine the *C1-01* value is as shown here:

$$C1-01 = \frac{120 \times 6048:2 \text{ (Hex)} \times E1-04 \text{ (Max. Motor Speed (Hz))}}{6048:1 \text{ (Hex)} \times E2-04 \text{ (Motor Poles)}}$$

Index (Hex.)	Subindex	Content	Access	PDO Mapping	Data Type	Value (Range)
6048	1	Acceleration Delta Speed; in rpm	Read Write	Rx/Tx	UNS32	(0 - 2 ³² -1)
6048	2	Acceleration Delta Time; in sec	Read Write	Rx/Tx	SINT32	(0 - 65535)

■ 6049 (Hex.): vl Velocity Deceleration

Note:

This object is not available for D1000 and R1000.

This object sets the deceleration ramp of the drive. Subindices 1 and 2 are mapped to *C1-02 [Deceleration Time I]*. The drive does an internal calculation on the value entered into this object. The formula to determine the *C1-02* value is as shown here:

$$C1-02 = \frac{120 \times 6049:2 \text{ (Hex)} \times E1-04 \text{ (Max. Motor Speed (Hz))}}{6049:1 \text{ (Hex)} \times E2-04 \text{ (Motor Poles)}}$$

Index (Hex.)	Subindex	Content	Access	PDO Mapping	Data Type	Value (Range)
6049	1	Acceleration Delta Speed; in rpm	Read Write	Rx/Tx	UNS32	(0 - 2 ³² -1)
6049	2	Acceleration Delta Time; in sec	Read Write	Rx/Tx	UNS16	(0 - 65535)

■ 604A (Hex.): vl Velocity Quick Stop

Note:

This object is not available for D1000 and R1000.

This object sets the Fast-Stop deceleration ramp of the drive. Subindices 1 and 2 are mapped to *C1-09 [Fast Stop Time]*. The drive does an internal calculation on the value entered into this object. The formula to determine the *C1-09* value is as shown here:

$$C1-09 = \frac{120 \times 604A:2 \text{ (Hex)} \times E1-04 \text{ (Max. Motor Speed (Hz))}}{604A:1 \text{ (Hex)} \times E2-04 \text{ (Motor Poles)}}$$

Index (Hex.)	Subindex	Content	Access	PDO Mapping	Data Type	Value (Range)
604A	1	Quick Stop Delta Speed; in rpm	Read Write	Rx/Tx	UNS32	(0 - 2 ³² -1)
604A	2	Quick Stop Delta Time; in sec	Read Write	Rx/Tx	UNS16	(0 - 65535)

■ 604C (Hex.): vl Dimension Factor

Note:

This object is not available for D1000 and R1000.

The vl dimension factor is multiplied with the target velocity. The quotient of the subindexes vl dimension factor numerator and vl dimension factor denominator determines the vl dimension factor.

The drive multiplies the following objects by the dimension factor and are always used in a product (multiplication):

Object (Hex.)	Object Name	Reference Page
6042	vl Target Velocity	55
6043	vl Velocity Demand	55
6044	vl Velocity Control Effort/Actual Value	55
6046	vl Velocity Min Max Amount	55
6048	vl Velocity Acceleration	56
6049	vl Velocity Deceleration	56
604A	vl Velocity Quick Stop	56

Index (Hex.)	Subindex	Content	Access	PDO Mapping	Data Type	Value (Range)
604C	1	vl Dimensions Factor numerator	Read Write	Rx/Tx	SINT32	1 (-2 ³¹ - 2 ³² -1)
604C	2	vl Dimensions Factor denominator	Read Write	Rx/Tx	SINT32	1 (-2 ³¹ - 2 ³² -1)

■ 604D (Hex.): vl Pole Number

Note:

This object is not available for D1000 and R1000.

This object sets the number of motor poles and calculates all speed related values in min⁻¹. This value aligns with the number of motor poles setting in the drive.

Index (Hex.)	Subindex	Content	Access	PDO Mapping	Data Type	Value (Range)
604D	0	vl Pole Number Mapped to: MEMOBUS/Modbus address 0311 (Hex.)/ E2-04 [Motor Pole Count]	Read Write	Tx	UNS8	4 (2 - 254)

■ 6060 (Hex.): Modes of Operation

Note:

This object is not available for D1000 and R1000.

This object shows the mode of the device. The object supports 2 (Velocity Mode) only. Refer to [Supported Modes of Operation on page 22](#) for information.

Supported modes:

Value	Description
2	Velocity Mode

Index (Hex.)	Subindex	Content	Access	PDO Mapping	Data Type	Value
6060	0	Modes of Operation	Read Write	Rx/Tx	SINT8	2

■ 6061 (Hex.): Modes of Operation Display

Note:

This object is not available for D1000 and R1000.

This object shows the mode of the device. Refer to [Supported Modes of Operation on page 22](#) for information.

Supported modes:

Value	Description
2	Velocity Mode
-2	Vendor Control Mode

Index (Hex.)	Subindex	Content	Access	PDO Mapping	Data Type	Value (Range)
6061	0	Modes of Operation	Read Only	Tx	SINT8	- (-2, 2)

■ 60FD (Hex.): Digital Inputs

This object contains the drive digital output status (seen as input to the network). The content of this object is equal to drive MEMOBUS/Modbus register 004A (Hex.)/UI-II [Output Terminal Status]. For more information, refer to the Technical Manual for your drive.

Bit defines:

Signature	Bit	GA700	Supplementary Information
LSB	0 - 15	0 (reserved)	-
	16	Terminals M1-M2	Refer to MEMOBUS/Modbus address 004A (Hex.) bit 0 to bit 7 in the Technical Manual of your drive for more information.
	17	Terminals M3-M4	
	18	Terminals P1-C1	
	19	Terminals P2-C2	
	20	0 (reserved)	
	21	0 (reserved)	
	22	0 (reserved)	
23	Faulty Relay MA/MB-MC		
MSB	24 - 31	0 (reserved)	-

Value	Description
1	ON
0	OFF

Index (Hex.)	Subindex	Content	Access	PDO Mapping	Data Type	Value (Range)
60FD	0	Drive Digital Input Status	Read Only	Tx	UNS32	- (0 - 2 ³² -1)

■ 60FE (Hex.): Digital Outputs

This object sets drive digital inputs (seen as output from the network).

Bit defines:

Signature	Bit	GA700	Supplementary Information
LSB	0 - 15	0 (reserved)	-
	16	Multi-function input command 1	Refer to MEMOBUS/Modbus address 0001 (Hex.) bit 4 to bit 9 in the Technical Manual of your drive for more information.
	17	Multi-function input command 2	
	18	Multi-function input command 3	
	19	Multi-function input command 4	
	20	Multi-function input command 5	
	21	Multi-function input command 6	Refer to MEMOBUS/Modbus address 0001 (Hex.) bit A to bit B in the Technical Manual of your drive for more information.
	22	Multi-function input command 7	
	23	Multi-function input command 8	
	24	External Fault (EF0)	Refer to MEMOBUS/Modbus address 0001 (Hex.) bit 2 to bit 3 in the Technical Manual of your drive for more information.
25	Fault Reset		
MSB	26 - 31	0 (reserved)	-

Value	Description
1	ON
0	OFF

Index (Hex.)	Subindex	Content	Access	PDO Mapping	Data Type	Value (Range)
60FE	0	Number of Elements	Read Only	-	UNS8	1
60FE	1	Physical Outputs	Read Write	Rx/Tx	UNS32	- (0 - 2 ³² -1)

■ 6502 (Hex.): Supported Drive Modes

Note:

This object is not available for D1000 and R1000.

This object displays the supported drive modes.

Index (Hex.)	Subindex	Content	Access	PDO Mapping	Data Type	Value
6502	-	Supported Drive Modes Mapped to: MEMOBUS/Modbus address 00020002 (Hex.) (vl velocity mode and vendor specific)	Read Only	Tx	UNS32	00020002 (Hex.)

9 Process Data Objects (PDO)

◆ Process Data Objects (PDO)

PDOs (Process Data Object) will be used for I/O exchange. PDOs are mapped to objects during configuration (PRE-OPERATIONAL state). TxPDOs transfer data from the option and RxPDOs transfer data to the option.

The Communication Option supports at least 8 parameters mapped to RxPDO and 8 parameters mapped to TxPDO.

The drive supports 17 Receive and 18 Transmit PDOs. The following tables show available PDOs, their default settings, and the objects required to set up when changing the PDO configuration or the PDO mapping.

■ Transmit PDOs (TxPDO)

The Transmit PDOs have a default mapping according to the table below. You can write to the map objects 1A00 (Hex.) - 1A50 (Hex.) to re-map Transmit PDOs. Refer to *Communication Profile Objects (DS 301) on page 22* for information.

Table 9.1 Transmit PDO Mapping

PDO Number	Mapped Objects (Hex.)	Index (Hex.)
1	Sub-index 1: 6041:0, 2-bytes (DSP402 status word)	1A00
2	Sub-index 1: 6041:0, 2-bytes (DSP402 status word) Sub-index 2: 6061:0, 2-bytes (DSP402 Modes of operation display)	1A01
6	Sub-index 1: 6041:0, 2-bytes (DSP402 status word) Sub-index 2: 6044:0, 2-bytes (vl control effort)	1A05
7	Sub-index 1: 6041:0, 2-bytes (DSP402 status word) Sub-index 2: 60FD:0, 4-bytes (Digital inputs)	1A06
21	Sub-index 1: 6042:0, 2-bytes (vl target velocity)	1A14
22	Sub-index 1: 6043:0, 2-bytes (vl velocity demand)	1A15
23	Sub-index 1: 6048:1, 4-bytes (vl Accel delta speed) Sub-index 2: 6048:2, 2-bytes (vl Accel delta time)	1A16
24	Sub-index 1: 6049:1, 4-bytes (vl Decel delta speed) Sub-index 2: 6049:2, 2-bytes (vl Decel delta time)	1A17
25	Sub-index 1: 604A:1, 4-bytes (vl quick-stop delta speed) Sub-index 2: 604A:2, 2-bytes (vl quick-stop delta time)	1A18
26	Sub-index 1: 604C:1, 4-bytes (vl Dimension factor) Sub-index 2: 604C:2, 4-bytes (vl Dimension factor)	1A19
36	Sub-index 1: 2100:1, 2-bytes (Drive status)	1A23
37	Sub-index 1: 2110:1, 2-bytes (Output frequency)	1A24
38	Sub-index 1: 2120:1, 2-bytes (Output current)	1A25
39	Sub-index 1: 2130:1, 2-bytes (Output torque reference)	1A26
40	Sub-index 1: 2140:1, 2-bytes (MEMOBUS/Modbus read response)	1A27

9 Process Data Objects (PDO)

PDO Number	Mapped Objects (Hex.)	Index (Hex.)
41	Sub-index 1: 2150:1, 2-bytes (MEMOBUS/Modbus write response)	1A28
42	Sub-index 1: 6041:0, 2-bytes (DSP402 status word) Sub-index 2: 6061:0, 1-byte (DSP402 Modes of operation display) Sub-index 3: 6044:0, 2-bytes (DSP402 vl velocity actual value) Sub-index 4: 60FD:0, 4-bytes (DSP402 Digital inputs) Sub-index 5: 6042:0, 2-bytes (DSP402 vl target velocity) Sub-index 6: 6043:0, 2-bytes (DSP402 vl velocity demand)	1A29
81	Sub-index 1: 2100:1, 2-bytes (Drive status) Sub-index 2: 5001:0, 2-bytes (Input voltage) Sub-index 3: 5003:0, 2-bytes (AC power) Sub-index 4: 2210:1, 2-bytes (DC bus voltage)	1A50

■ Receive PDOs (RxPDO)

The Receive PDOs have a default mapping as specified by the table below. You can write to the map objects 1600 (Hex.) - 1650 (Hex.) to re-map Receive PDOs. Refer to *Communication Profile Objects (DS 301) on page 22* for information.

Table 9.2 Receive PDO Mapping

PDO Number	Mapped Objects (Hex.)	Index (Hex.)
1	Sub-index 1: 6040:0, 2-bytes (DSP402 control word)	1600
2	Sub-index 1: 6040:0, 2-bytes (DSP402 control word) Sub-index 2: 6060:0, 1-bytes, (DSP402 Modes of operation)	1601
6	Sub-index 1: 6040:0, 2-bytes (DSP402 control word) Sub-index 2: 6042:0, 2-bytes, (vl target velocity)	1605
7	Sub-index 1: 6040:0, 2-bytes (DSP402 control word) Sub-index 2: 60FE:1, 4-bytes, (Physical digital outputs)	1606
8	Sub-index 1: 6040:0, 2-bytes (DSP402 control word) Sub-index 2: 6060:0, 1-bytes, (DSP402 Modes of operation)	1607
21	Sub-index 1: 6048:1, 4-bytes (vl Accel delta speed) Sub-index 2: 6048:2, 2-bytes (vl Accel delta time)	1614
22	Sub-index 1: 6049:1, 4-bytes (vl Decel delta speed) Sub-index 2: 6049:2, 2-bytes, (vl Decel delta time)	1615
23	Sub-index 1: 604A:1, 4-bytes (vl quick-stop delta speed) Sub-index 2: 604A:2, 2-bytes (vl quick-stop delta time)	1616
24	Sub-index 1: 604C:1, 4-bytes (vl Dimension factor) Sub-index 2: 604C:2, 4-bytes, (vl Dimension factor)	1617
36	Sub-index 1: 2000:1, 2-bytes (Operation command)	1623
37	Sub-index 1: 2010:1, 2-bytes (Speed reference/limit)	1624
38	Sub-index 1: 2020:1, 2-bytes (Torque reference/limit)	1625
39	Sub-index 1: 2030:1, 2-bytes (Torque compensation)	1626
40	Sub-index 1: 2040:1, 4-bytes (MEMOBUS read request)	1627
41	Sub-index 1: 2050:1, 4-bytes (MEMOBUS write request)	1628
42	Sub-index 1: 6040:0, 2-bytes (DSP402 control word) Sub-index 2: 6042:0, 2-bytes (vl target velocity) Sub-index 3: 6048:1, 4-bytes (vl Accel delta speed) Sub-index 4: 6048:2, 2-bytes (vl Accel delta time) Sub-index 5: 6049:1, 4-bytes (vl Decel delta speed) Sub-index 6: 6049:2, 2-bytes (vl Decel delta time) Sub-index 7: 6046:1, 4-bytes (vl velocity min amount) Sub-index 8: 6046:2, 4-bytes (vl velocity max amount)	1629
81	Sub-index 1: 2000:1, 2-bytes (Operation command)	1650

■ RxPDO Mapped Drive Registers Above 0100 (Hex.) Range

You can configure drive registers up to 00FF (Hex.) as process data exchanged on each I/F scan cycle. You cannot exchange drive registers from 0100 (Hex.) on each I/F scan cycle.

To be able to RxPDO map those objects on EtherCAT, there is a “slow” IO channel inside the option system firmware. This slow IO channel uses the overlaid MEMOBUS/Modbus channel in I/F to write the drive registers required.

When the RxPDO mapping is done on any drive register and the address is larger than 0100 (Hex.), it is added to the slow IO control set. ENTER command management for slow IO channel control sets:

- New value only written against drive if it changes from the previously written value.
- If a value update is detected, the write will be scheduled directly after the RxPDO EtherCAT process data cycle is complete.
- If the written value from MEMOBUS/Modbus fails (for example, it cannot write a parameter when the drive is running), a new retry will be triggered after 8 ms.
- If a RAM ENTER command is necessary for the drive to use the written value, the ENTER command will be written when the last register that should be updated in a slow IO data scan set update is triggered.
I.e mapped drive registers: A: 0200 (Hex.), B: 0201 (Hex.), C: 0203 (Hex.)
 - All three registers change at the same time: RAM ENTER command executed with C.
 - Only register 0200 (Hex.) changes: RAM ENTER command executed with A.

Table 9.3 Objects Managed in the Slow IO Channel

CoE Object (Hex.)	Linked INV Register	Information
2080, 2090, 20A0, 20B0, 20C0, 3000, 3100	If subindex 2 MEMOBUS address is > 0100 (Hex.) that address is linked.	Configurable input objects
2040, 2140	Register address in MEMOBUS read payload	Overlaid MEMOBUS read channel, request and response CoE objects.
2050, 2150	Register address in MEMOBUS write payload	Overlaid MEMOBUS write channel, request and response CoE objects. Note: No ENTER command is executed for this request. You must use object 2060 (Hex.) to manage it manually.
2060, 2160	0910 (Hex.) (RAM Enter)	MEMOBUS RAM (un-memorized) Enter command
6046:1	028A (Hex.) / d2-02 [Frequency Reference Lower Limit]	Inverter frequency reference lower limit
6046:2	0289 (Hex.) / d2-01 [Frequency Reference Upper Limit]	Inverter frequency reference upper limit
6048:1, 6048:2	0200 (Hex.) / C1-01 [Acceleration Time 1]	v1 velocity acceleration #1 = delta speed #2 = delta time
6049:1, 6049:2	0201 (Hex.) / C1-02 [Deceleration Time 1]	v1 velocity deceleration #1 = delta speed #2 = delta time
604A:1, 604A:2	0208 (Hex.) / C1-09 [Fast Stop Time]	v1 velocity quick stop #1 = delta speed #2 = delta time

10 Examples

◆ Example Project with SPEED7

The following example shows how to make the YASKAWA EtherCAT communication option available in a SPEED7 Studio project.

Note:

The graphics were created using SPEED7 Studio version 2016 [clarify]. The software user interface is different for different versions.

1. Click [Extra] > [Install device description file (EtherCAT ESI)] to import the device description file for the communication option.

2. In the projecting view, right-click the [EC-Mastersystem (100)] and select [Add new device....].

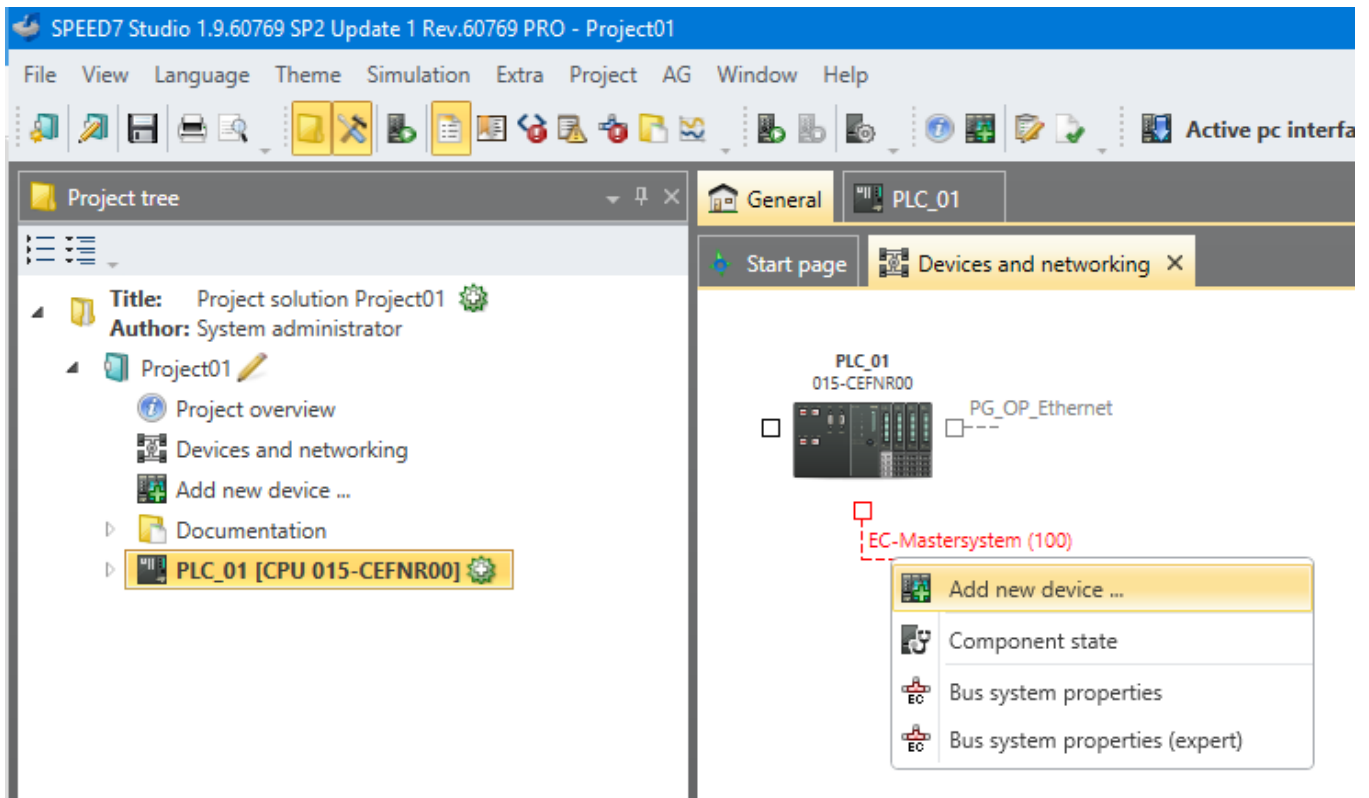

3. In the dialog box, select [ESI] on the left pane.

4. Navigate to [Vendor] > [Yaskawa Electric Corporation] > [Drives] and select your drive. Confirm with [OK].

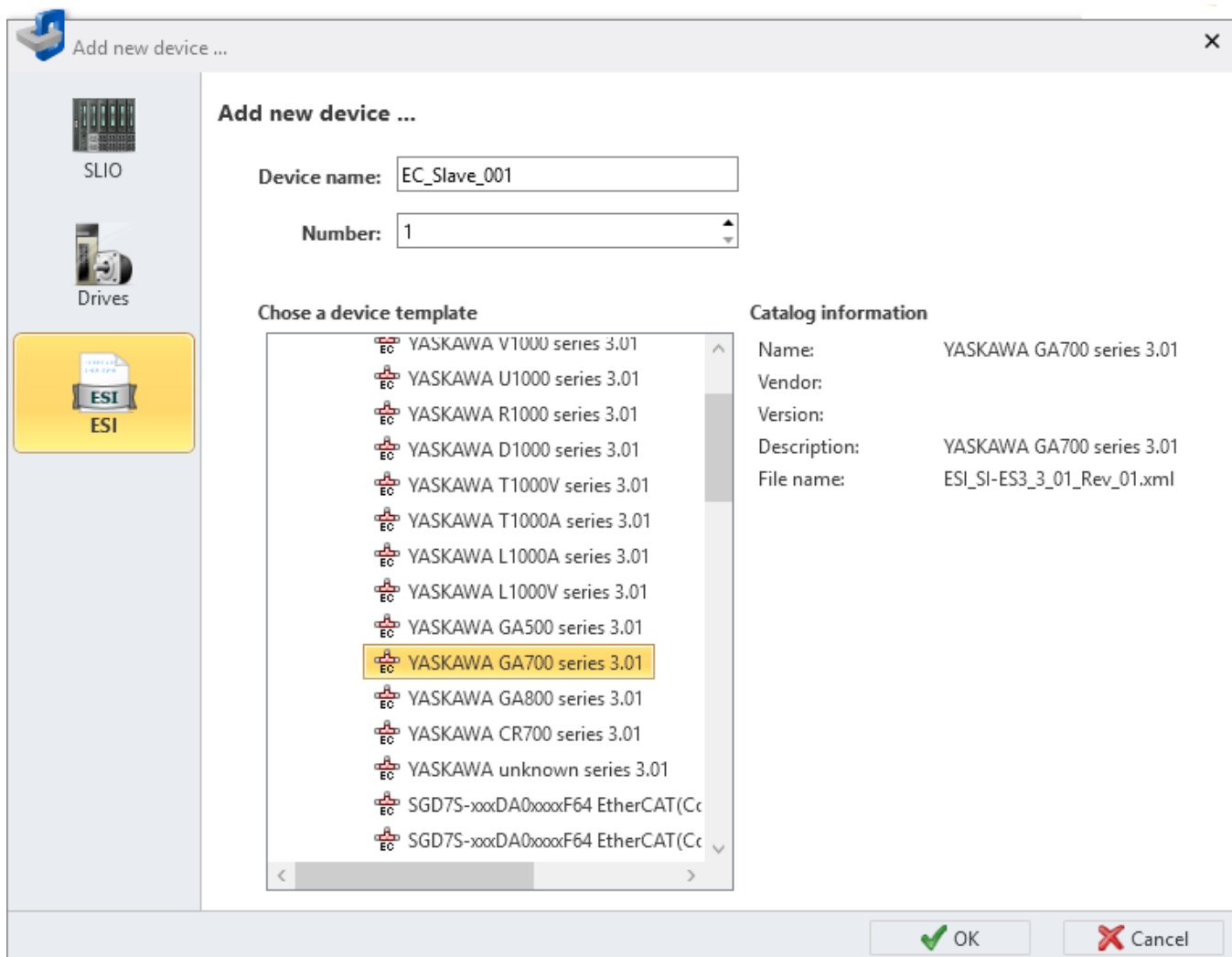

After following the procedure, the drive is ready for further use.

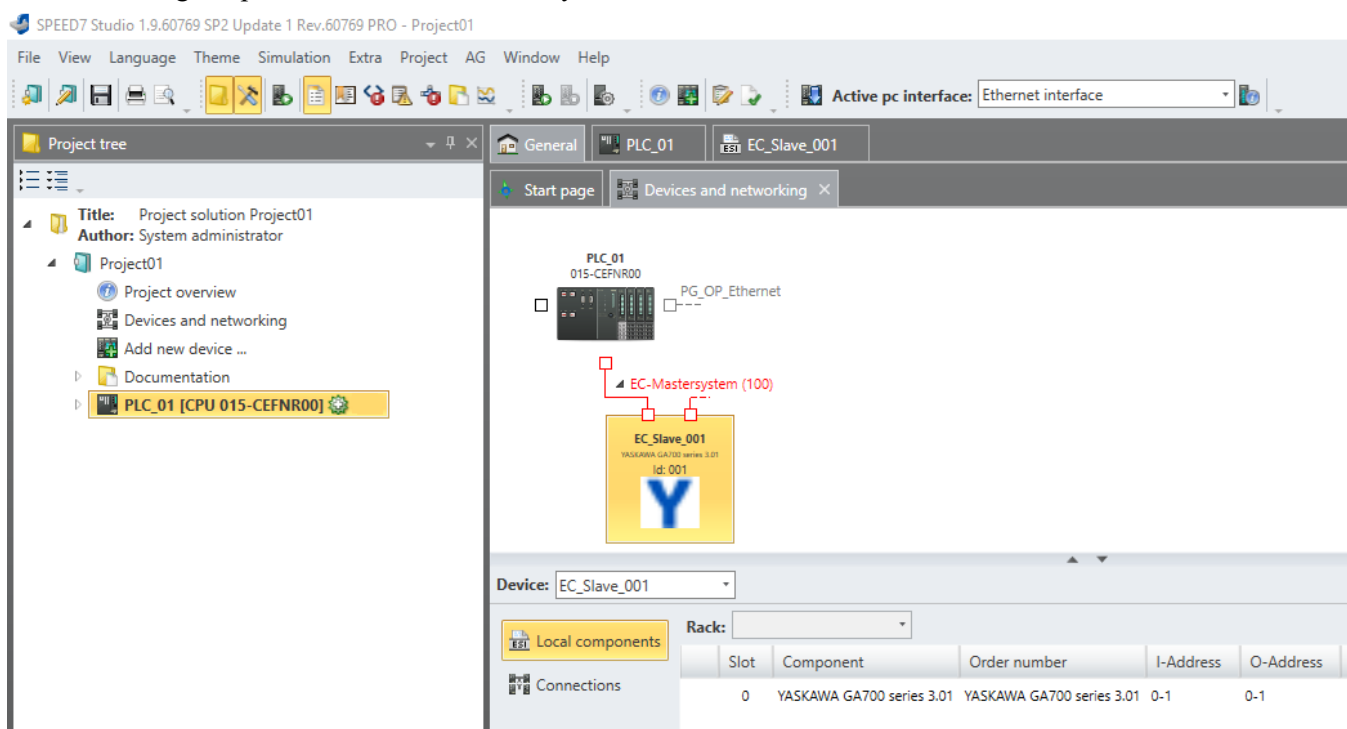

◆ Example Project with TwinCAT System Manager

The following example shows how to make the YASKAWA EtherCAT communication option available in a Beckhoff TwinCAT System Manager.

Note:

The graphics were created using TwinCAT System Manager version 2.11. The software user interface is different for different versions.

1. Click [Action] > [Import XML Description...] to import the device description file for the communication option.
2. In the project tree, right-click [Devices] in the [I/O] node and select [Scan].

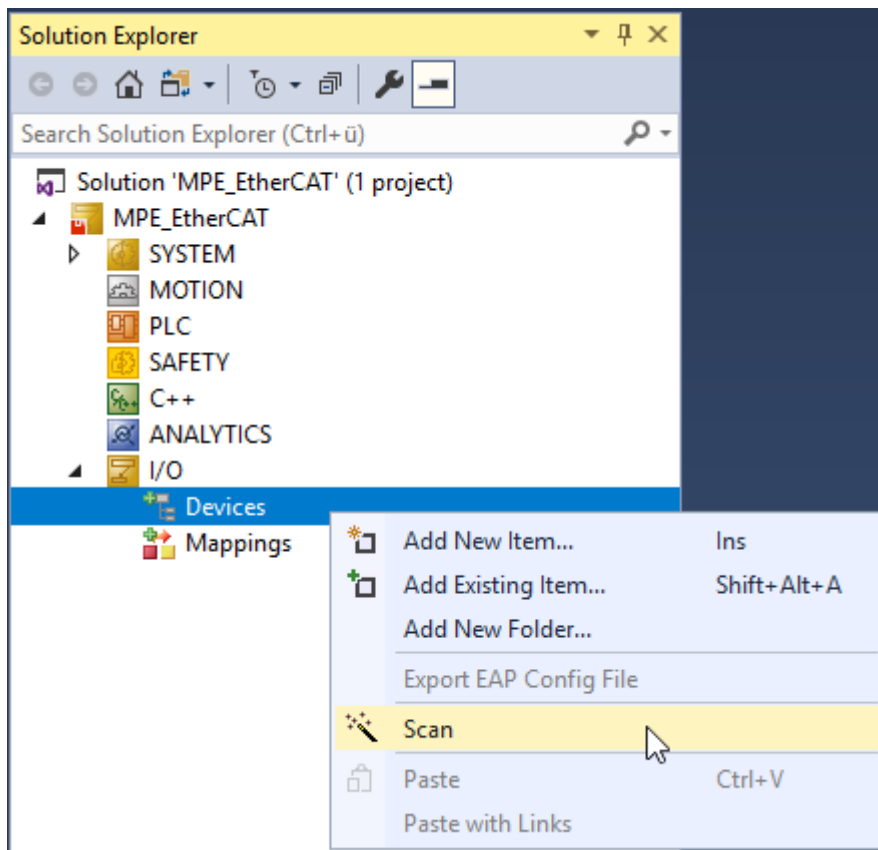

3. Select the EtherCAT device and confirm with [OK].

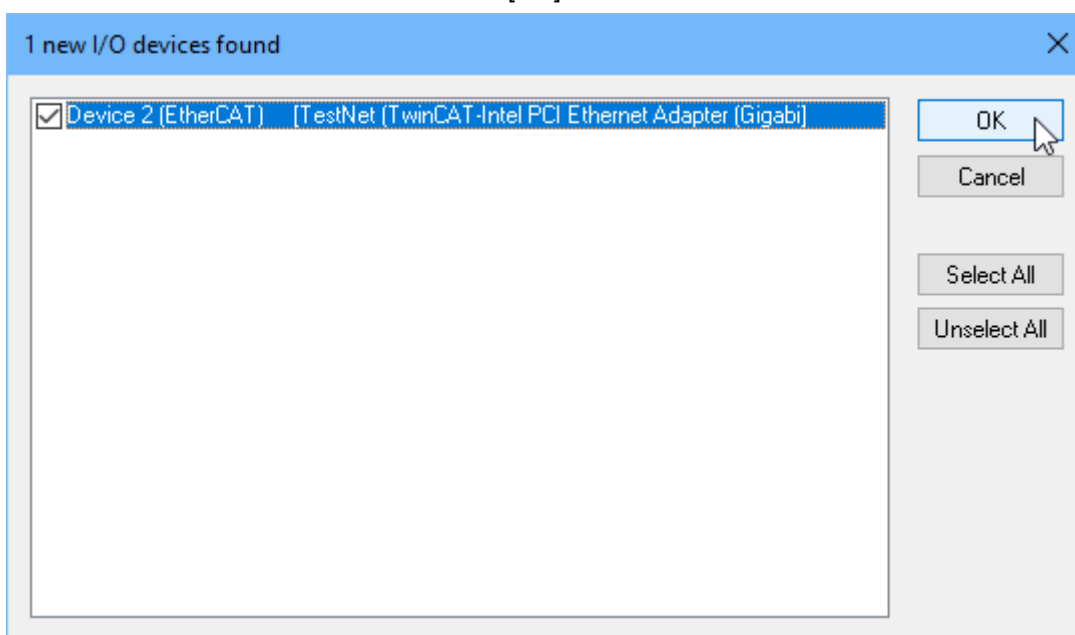

4. TwinCAT System Manager will ask you to scan for boxes. Select [Yes].

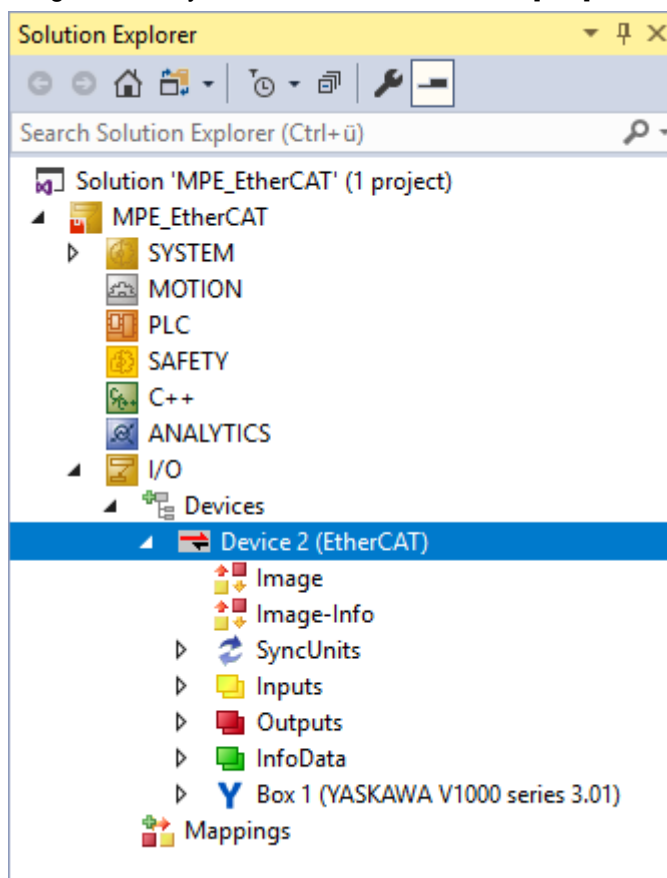

After following the procedure, the drive is ready for further use.

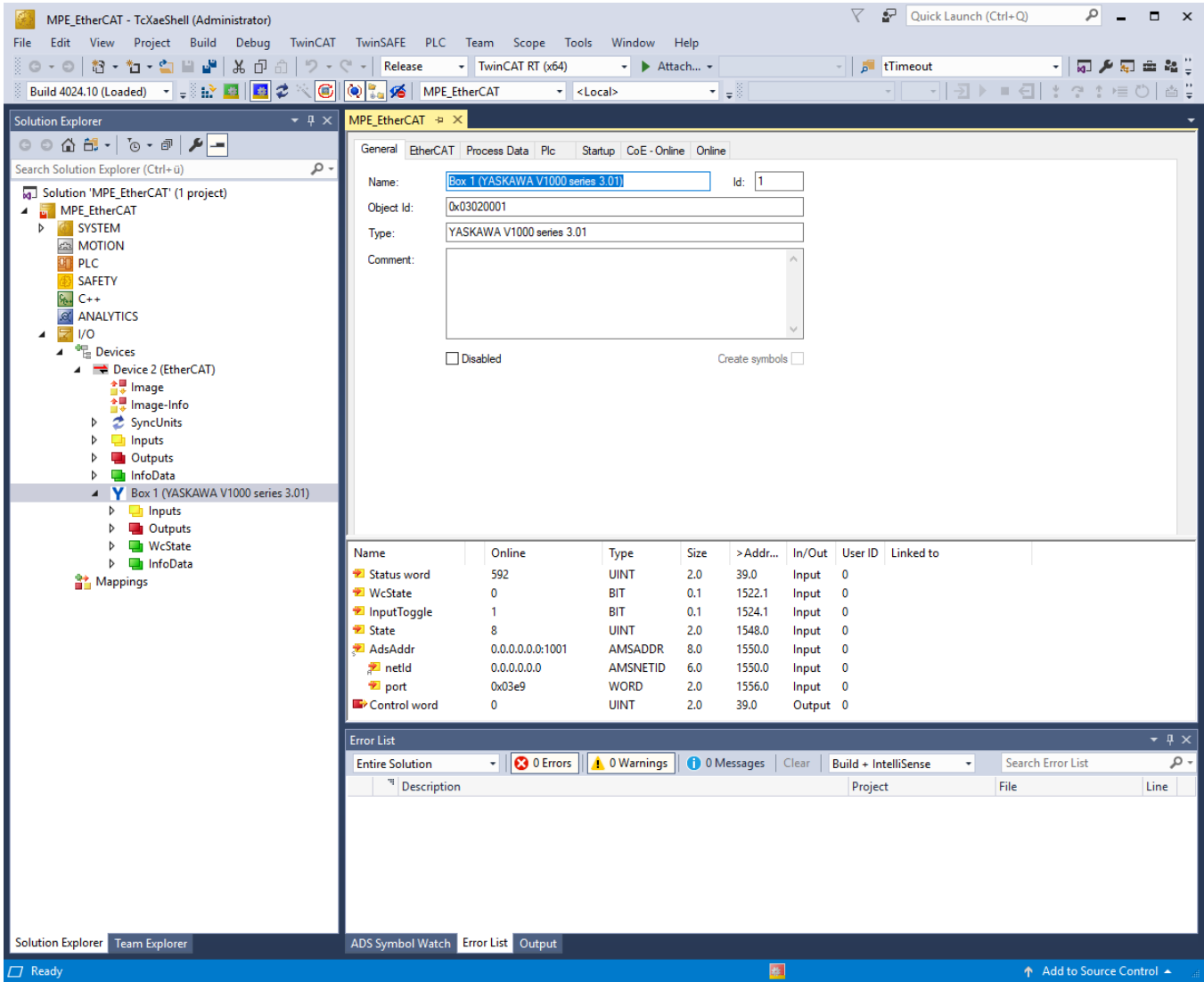

◆ Example to Select MEMOBUS/Modbus Register into Freely Configurable Objects

The following example shows how to select MEMOBUS/Modbus register into freely configurable objects.

Example: Select MEMOBUS/Modbus register 1950 (Hex.) into freely configurable output object 2180 (Hex.) in TwinCAT 3.

1. Select the freely configurable output object 2180 (Hex.) subindex 1 into the input TxPDO of the PLC. The freely configurable output object 2180 (Hex.) subindex 1 will contain the value of the MEMOBUS/Modbus register that we are reading.

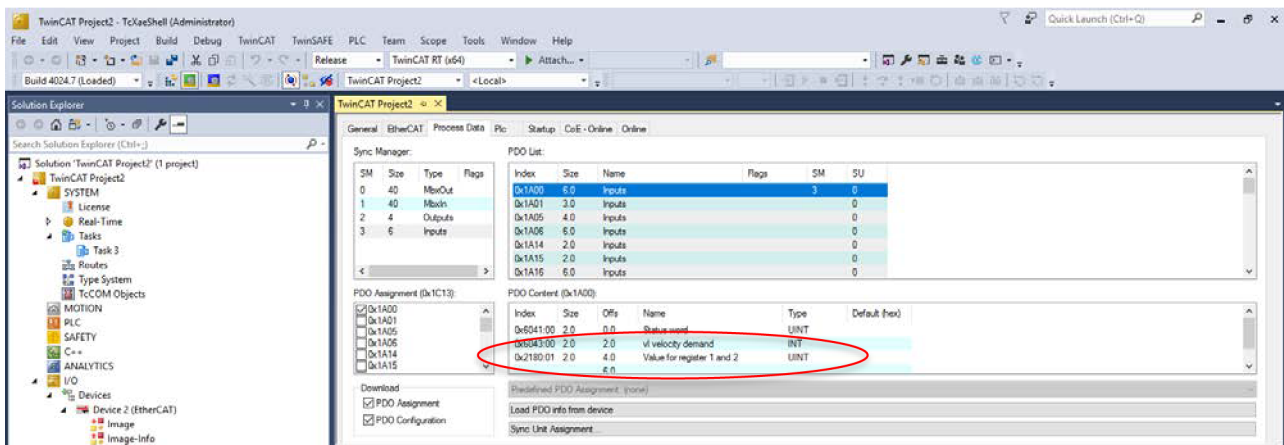

- Write a MEMOBUS/Modbus register to the freely configurable output object 2180 (Hex.) and determine the MEMOBUS/Modbus register to be read.

This can be done in [Startup].

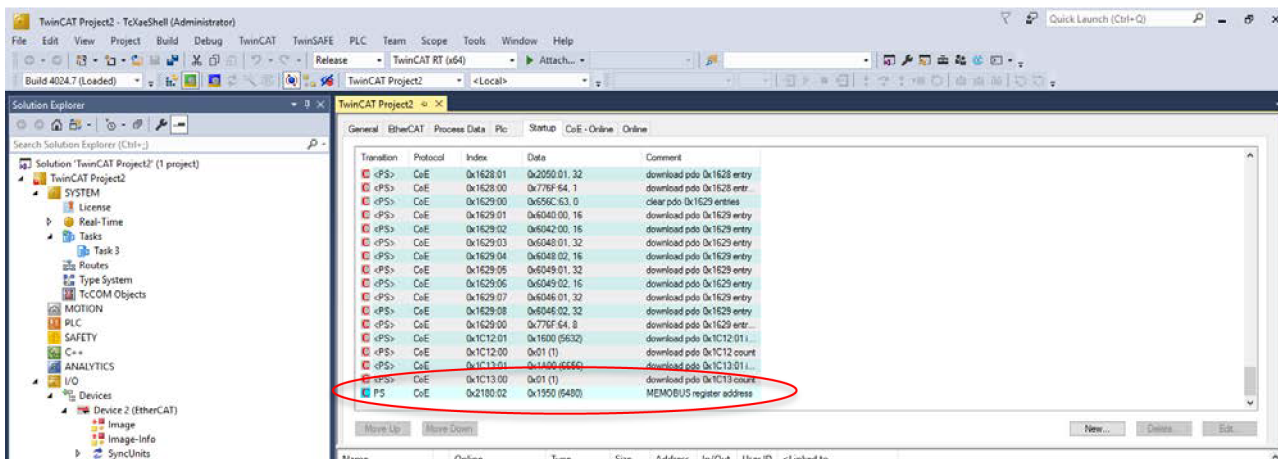

- In the [Startup], you can add a new startup message by clicking on [New...] on the bottom right to open a new window where you can select [2180 02 MEMOBUS register address].

Be careful that you select [2180 02 MEMOBUS register address], otherwise you will get an error during TwinCAT 3 startup.

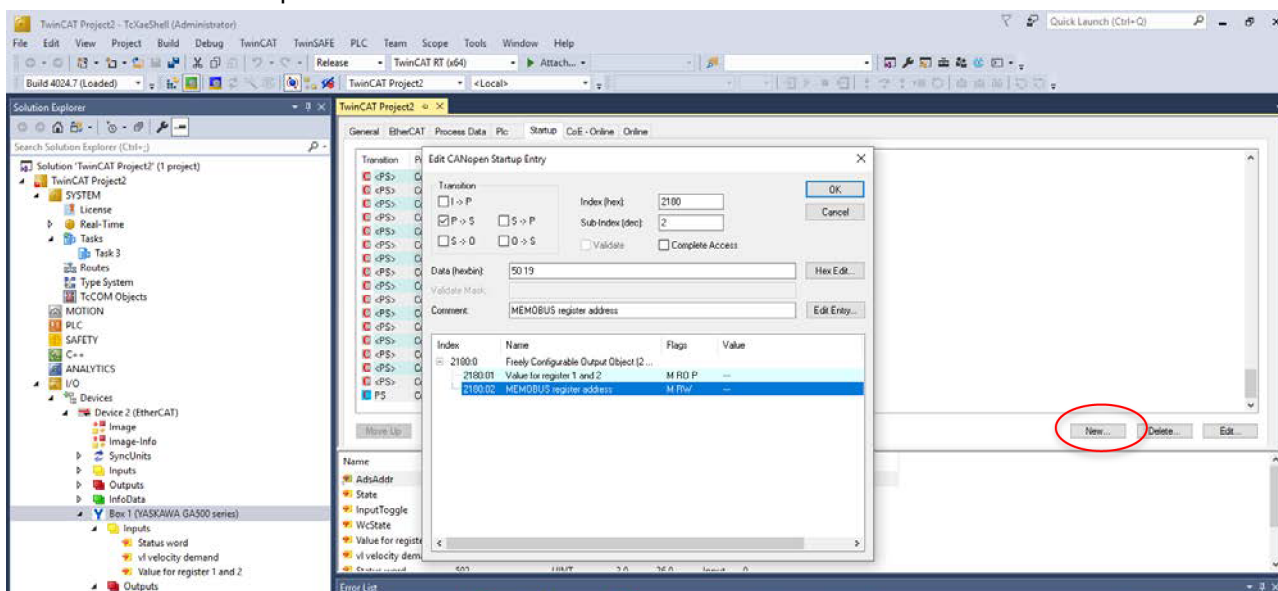

- By double clicking on [2180 02 MEMOBUS register address], you can set a startup value which will be written in the freely configurable output object 2180 (Hex.) subindex 2 during P->S (PREOP to SAFEOP). There you should set the MEMOBUS/Modbus register you want to be coupled to the freely configurable input/output. Example: MEMOBUS/Modbus register 1950 (Hex.) (drive monitor U8-01 [DWEZ Monitor 1]).

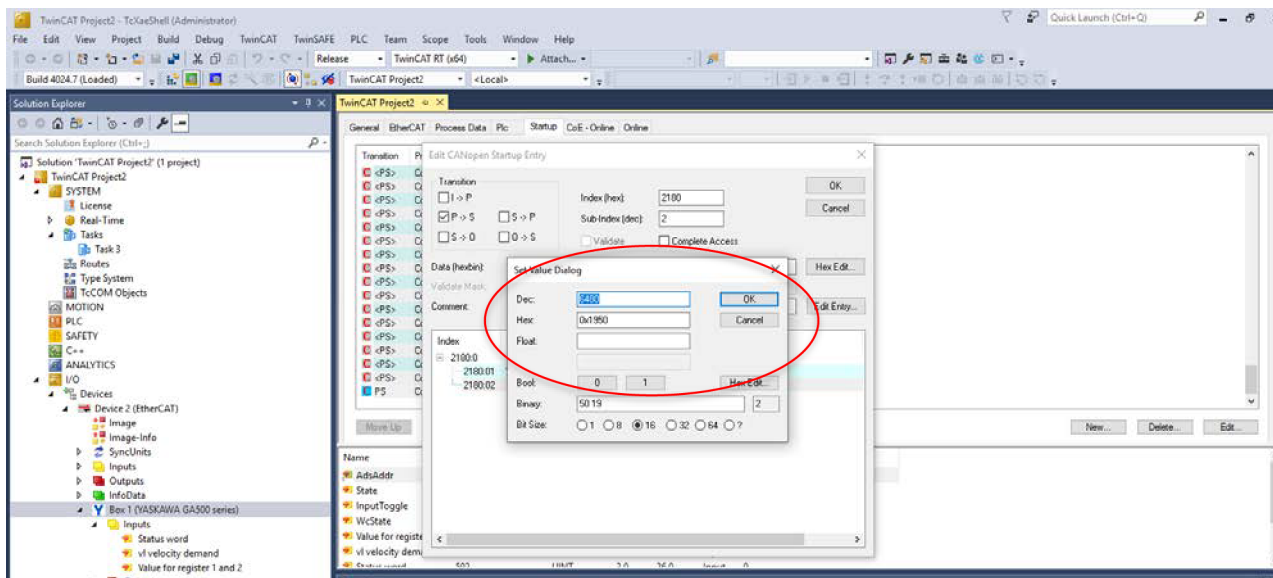

- Now after the TwinCAT 3 startup, the freely configurable output object 2180 (Hex.) subindex 1 will show the value of the MEMOBUS/Modbus register 1950 (Hex.).

11 Troubleshooting

◆ EtherCAT Option Card Error Codes

If there is a fault or alarm in the drive, the fault or alarm will be stored in consecutive subindices of object 1003 (Hex.). Additionally, an emergency telegram will be sent once.

Index (Hex.)	Subindex	Description	Access	PDO Mapping	Data Type	Value (Range)
1003	0	Number of errors	Read Write	No	UNS8	00 (Hex.) (00 - FF (Hex.))
1003	1	Standard error field (Emergency error code)	Read Only	No	UNS32	0000 (Hex.) (0000 - FF8 (Hex.))

Table 11.1 Emergency Telegram Specification

Byte	0	1	2	3	4	5	6	7
Content	Emergency Error Code			Error register object 1001 (Hex.) = 1	Manufacturer specific error info. Not used. Set to zero.			

■ Emergency Error Codes

Table 11.2 Error Code List

Error Code (Hex.)	Meaning	Drive Display	Numeric Value of MEMOBUS/Modbus Address 0080 (Hex.)
0000	No error	No error	00
5450	DC Bus Fuse Open	FUd	01
3220	DC Bus Undervoltage	Uv1	02
5200	Control Power Undervoltage	Uv2	03
3221	Soft Charge Answerback Fault	Uv3	04
2340	Short Circuit/IGBT Failure	SC	05
2330	Ground Fault	GF	06
2220	Overcurrent	oC	07
3210	Overvoltage	ov	08
4280	Heatsink Overheat	oH	09
4210	Heatsink Overheat	oH1	0A
2310	Motor Overload	oL1	0B

Error Code (Hex.)	Meaning	Drive Display	Numeric Value of MEMOBUS/Modbus Address 0080 (Hex.)
2221	Drive Overload	oL2	0C
2311	Overtorque Detection 1	oL3	0D
2312	Overtorque Detection 2	oL4	0E
5420	Dynamic Braking Transistor Fault	rr	0F
4410	Braking Resistor Overheat	rH	10
5441	External Fault (Terminal S3)	EF3	11
5442	External Fault (Terminal S4)	EF4	12
5443	External Fault (Terminal S5)	EF5	13
5444	External Fault (Terminal S6)	EF6	14
5445	External Fault (Terminal S7)	EF7	15
5480	External Fault (Terminal S8)	EF8	16
FF01	Internal Fan Fault	FAn	17
7180	Overspeed	oS	18
8321	Speed Deviation	dEv	19
7305	Encoder (PG) Feedback Loss	PGo	1A
3130	Input Phase Loss	PF	1B
3300	Output Phase Loss	LF	1C
FF02	Motor Overheat (PTC Input)	oH3	1D
5300	Keypad Connection Fault	oPr	1E
5530	EEPROM Write Error	Err	1F
4310	Motor Overheat Fault (PTC Input)	oH4	20
FF03	Modbus Communication Error	CE	21
FF04	Option Communication Error	bUS	22
FF05	Control Fault	CF	25
8313	Zero Servo Fault	SvE	26
5481	Option Card External Fault	EF0	27
FF06	PID Feedback Loss	FbL	28
FF07	Undertorque Detection 1	UL3	29
FF08	Undertorque Detection 2	UL4	2A
FF09	High Slip Braking Overload	oL7	2B
FF0A	External Fault (Terminal S9)	EF9	2C
FF0B	External Fault (Terminal S10)	EF10	2D
FF0C	External Fault (Terminal S11)	EF11	2E
FF0D	External Fault (Terminal S12)	EF12	2F
6000	Hardware Fault	oFx	30
FF0E	Z Pulse Fault	dv1	32
FF0F	Z Pulse Noise Fault Detection	dv2	33
FF10	Inversion Detection	dv3	34
FF11	Inversion Prevention Detection	dv4	35
FF12	Output Current Imbalance	LF2	36
FF13	Motor Step-Out Detected	STPo */	37
FF14	Encoder (PG) Hardware Fault	PGoH	38
FF15	MECHATROLINK Watchdog Timer Err	E5	39
FF16	Speed Search Retries Exceeded	SEr	3B
FF17	Reserved	CASEFAL1	3C
FF18	Reserved	CASEFAL2	3D

11 Troubleshooting

Error Code (Hex.)	Meaning	Drive Display	Numeric Value of MEMOBUS/Modbus Address 0080 (Hex.)
FF19	Reserved	CASEFAL3	3E
FF1A	Reserved	CASEFAL4	3F
FF1B	Reserved	CASEFAL5	40
FF1C	Excessive PID Feedback	FbH	41
FF1D	External Fault (Terminal S1)	EF1	42
FF1E	External Fault (Terminal S2)	EF2	43
FF1F	Mechanical Weakening Detection 1	oL5	44
FF20	Mechanical Weakening Detection 2	UL5	45
FF21	Current Offset Fault	CoF	46
FF22	PLC Fault 1	PE1	47
FF23	PLC Fault 2	PE2	48
FF24	DriveWorksEZ Fault	dWFL	49
6301	Error during object content selection	-	-
FF25	EEPROM Memory DWEZ Data Error	dWF1	4A
FF26	DriveWorksEZ Fault 2	dWF2	4B
FF27	DriveWorksEZ Fault 3	dWF3	4C
FF28	Output Voltage Detection Fault	voF	4D
FF29	Braking Resistor Fault	rF	4E
FF2A	Braking Transistor Overload Fault	boL	4F
FF2B	Motor Overheat (NTC Input)	oH5	50
FF2C	Low Speed Motor Step-Out	LSo	51
FF2D	Node Setup Error	nSE	52
FF2E	Thermistor Disconnect	THo	53
FF2F	Over Jerk	dv6	54
FF30	Motor Contactor Response Error	SE1	55
FF31	Starting Current Error	SE2	56
FF32	Output Current Error	SE3	57
FF33	Brake Response Error	SE4	58
FF34	Speed Reference Missing	FrL	59
FF35	Polarity Judge Timeout	dV7	5B
FF36	GF1 Error	GF1	5C
FF37	Output Phase Loss 3	LF3	5F
FF38	Current Imbalance	UnbC	60
FF39	Gate Drive Board Power Supply Voltage Low	Uv4	61
FF3A	Power Supply Undervoltage	AUv	66
FF3B	Power Supply Overvoltage	Aov	67
FF3C	Power Supply Frequency Fault	Fdv	68
FF3D	Phase Order Detection Fault	SrC	69
FF3E	Power Supply Undervoltage Pre-Alarm	PAUv	6B
FF3F	DC Bus Fuse Open	FUA	70
FF40	Resonance Detection	vrE	71
FF41	Control Circuit Error	CPF00	81
FF42	Control Circuit Error	CPF01	82
FF43	A/D Conversion Failure	CPF02	83
FF44	PWM Motor Failure	CPF03	84
FF45	EEPROM Memory Data Error	CPF06	87

Error Code (Hex.)	Meaning	Drive Display	Numeric Value of MEMOBUS/Modbus Address 0080 (Hex.)
FF46	Terminal Board Connection Error	CPF07	88
FF47	EEPROM Serial Communications Error	CPF08	89
FF48	Option RAM Error	CPF11	8C
FF49	FLASH Memory Fault	CPF12	8D
FF4A	Watchdog Circuit Exception	CPF13	8E
FF4B	Control Circuit Error	CPF14	8F
FF4C	Clock Fault	CPF16	91
FF4D	Timing Fault	CPF17	92
FF4E	Control Circuit Fault	CPF18	93
FF4F	Control Circuit Fault	CPF19	94
FF50	Hardware Fault (at power ON)	CPF20	95
FF51	Hardware Fault (after communication start up)	CPF21	96
FF52	A/D Conversion Failure	CPF22	97
FF53	PWM Feedback Fault	CPF23	98
FF54	Drive Unit Signal Fault	CPF24	99
FF55	Terminal Board not Connected	CPF25	9A
FF56	ASIC BB Circuit Error	CPF26	9B
FF57	ASIC PWM Setting Register Error	CPF27	9C
FF58	ASIC PWM Pattern Error	CPF28	9D
FF59	ASIC On-Delay Error	CPF29	9E
FF5A	ASIC BB On Error	CPF30	9F
FF5B	ASIC Code Error	CPF31	A0
FF5C	ASIC Start-up Error	CPF32	A1
FF5D	Watchdog Circuit Exception Circuit Fault	CPF33	A2
FF5E	ASIC Power, Clock Error	CPF34	A3
FF5F	External A/D Conversion Failure	CPF35	A4
FF60	ASIC COM Error	CPF36	A5
FF61	ASIC COM Error	CPF37	A6
FF62	EEPROM Data Error	CPF38	A7
FF63	Control Circuit Error	CPF40	A9
FF64	Control Circuit Error	CPF41	AA
FF65	Control Circuit Error	CPF42	AB
FF66	Control Circuit Error	CPF43	AC
FF67	Control Circuit Error	CPF44	AD
FF68	Control Circuit Error	CPF45	AE
FF69	Option Not Compatible with Port	oFA00	101
FF6A	Option Fault/Connection Error	oFA01	102
FF6B	Duplicate Options	oFA02	103
FF6C	Option Card Error Occurred at Option Port CN5-A	oFA03	104
FF6D	Option Card Error Occurred at Option Port CN5-A	oFA04	105
FF6E	Option A/D Error	oFA05	106
FF6F	Option Communication Error	oFA06	107
FF70	Option RAM Error	oFA10	111
FF71	Option Card Error Occurred at Option Port CN5-A	oFA11	112
FF72	Option Card Error Occurred at Option Port CN5-A	oFA12	113
FF73	Option Card Error Occurred at Option Port CN5-A	oFA13	114

11 Troubleshooting

Error Code (Hex.)	Meaning	Drive Display	Numeric Value of MEMOBUS/Modbus Address 0080 (Hex.)
FF74	Option Card Error Occurred at Option Port CN5-A	oFA14	115
FF75	Option Card Error Occurred at Option Port CN5-A	oFA15	116
FF76	Option Card Error Occurred at Option Port CN5-A	oFA16	117
FF77	Option Card Error Occurred at Option Port CN5-A	oFA17	118
FF78	COM ID Error	oFA30	131
FF79	Type Code Error	oFA31	132
FF7A	SUM Check Error	oFA32	133
FF7B	Option Receive Time Over	oFA33	134
FF7C	Memobus Time Over	oFA34	135
FF7D	Drive Receive Time Over 1	oFA35	136
FF7E	CI Check Error	oFA36	137
FF7F	Drive Receive Time Over 2	oFA37	138
FF80	Control Reference Error	oFA38	139
FF81	Drive Receive Time Over 3	oFA39	13A
FF82	Control Response Selection 1 Error	oFA40	13B
FF83	Drive Receive Time Over 4	oFA41	13C
FF84	Control Response Selection 2 Error	oFA42	13D
FF85	Drive Receive Time Over 5	oFA43	13E
FF86	Option Not Compatible with Port	oFb00	201
FF87	Option Fault/Connection Error	oFb01	202
FF88	Duplicate Options	oFb02	203
FF89	Option A/D Error	oFb05	206
FF8A	Option Communication Error	oFb06	207
FF8B	Option RAM Error	oFb10	211
FF8C	Option Card Error Occurred at Option Port CN5-B	oFb11	212
FF8D	Option Card Error Occurred at Option Port CN5-B	oFb12	213
FF8E	Option Card Error Occurred at Option Port CN5-B	oFb13	214
FF8F	Option Card Error Occurred at Option Port CN5-B	oFb14	215
FF90	Option Card Error Occurred at Option Port CN5-B	oFb15	216
FF91	Option Card Error Occurred at Option Port CN5-B	oFb16	217
FF92	Option Card Error Occurred at Option Port CN5-B	oFb17	218
FF93	COM ID Error	oFb30	231
FF94	Type Code Error	oFb31	232
FF95	SUM Check Error	oFb32	233
FF96	Option Receive Time Over	oFb33	234
FF97	Memobus Time Over	oFb34	235
FF98	Drive Receive Time Over 1	oFb35	236
FF99	CI Check Error	oFb36	237
FF9A	Drive Receive Time Over 2	oFb37	238
FF9B	Control Reference Error	oFb38	239
FF9C	Drive Receive Time Over 3	oFb39	23A
FF9D	Control Response Selection 1 Error	oFb40	23B
FF9E	Drive Receive Time Over 4	oFb41	23C
FF9F	Control Response Selection 2 Error	oFb42	23D
FFA0	Drive Receive Time Over 5	oFb43	23E
FFA1	Option Not Compatible with Port	oFC00	301

Error Code (Hex.)	Meaning	Drive Display	Numeric Value of MEMOBUS/Modbus Address 0080 (Hex.)
FFA2	Option Fault/Connection Error	oFC01	302
FFA3	Duplicate Options	oFC02	303
FFA4	Option A/D Error	oFC05	306
FFA5	Option Communication Error	oFC06	307
FFA6	Option RAM Error	oFC10	311
FFA7	Option Card Error Occurred at Option Port CN5-C	oFC11	312
FFA8	Option Card Error Occurred at Option Port CN5-C	oFC12	313
FFA9	Option Card Error Occurred at Option Port CN5-C	oFC13	314
FFAA	Option Card Error Occurred at Option Port CN5-C	oFC14	315
FFAB	Option Card Error Occurred at Option Port CN5-C	oFC15	316
FFAC	Option Card Error Occurred at Option Port CN5-C	oFC16	317
FFAD	Option Card Error Occurred at Option Port CN5-C	oFC17	318
FFAE	Option Card Error Occurred at Option Port	oFC50	351
FFAF	Option Card Error Occurred at Option Port	oFC51	352
FFB0	Option Card Error Occurred at Option Port	oFC52	353
FFB1	Option Card Error Occurred at Option Port	oFC53	354
FFB2	Option Card Error Occurred at Option Port	oFC54	355
FFB3	Option Card Error Occurred at Option Port	oFC55	356
FFB4	Damping Resistor Overheat	doH	408
FFB5	Snubber Discharge Resistor Overheat	SoH	409
FFB6	Internal Resistance Fault	Srr	40A
FFB7	Safety Circuit Fault	SCF	40F
FFB8	Drive Cooling Fan Fault	FAn1	413
FFC0	Comparator 1 Limit Error	CP1	414
FFC1	Comparator 2 Limit Error	CP2	415
FFC2	Bluetooth Communication Fault	bCE	416
FFC3	Communication Error1	dCE1	41A
FFC4	Communication Error2	dCE2	41B
FFC5	Overcurrent 2	oC2	45F

*1 An *Sto* fault is displayed when connecting A1000.

■ SDO Abort Codes

SDO abort codes are supported as specified in DS301.

◆ Drive-Side Error Codes

Drive-side error codes appear on the drive keypad. *Fault on page 73* lists causes of the errors and possible corrective actions. Refer to the drive Technical Manual for additional error codes that can appear on the drive keypad.

■ Fault

This section gives information about some of the causes and possible solutions of faults. You must use the Fault Reset operation to remove the fault before you can operate the drive. Use the information in this table to remove the cause of the fault.

Code	Name	Causes	Possible Solutions
bUS	Option Communication Error	The drive did not receive a signal from the controller.	<ul style="list-style-type: none"> Check for wiring errors. Correct the wiring.
		The communications cable wiring is incorrect.	
		An existing short circuit or communications disconnection	Check disconnected cables and short circuits and repair as needed.

Code	Name	Causes	Possible Solutions
		A data error occurred due to electric interference	<ul style="list-style-type: none"> Prevent noise in the control circuit, main circuit, and ground wiring. If you identify a magnetic contactor as a source of noise, install a surge absorber to the contactor coil. Use only recommended cables or other shielded line. Ground the shield on the controller side or the drive input power side. Separate all communication wiring from drive power lines. Install an EMC noise filter to the drive power supply input. Decrease the effects of electrical interference from the controller.
		Option is damaged	If there are no problems with the wiring and the error continues to occur, replace the option.
		Connection Time-out	Check if the CPU of the controller is not stopped.
EF0	Option Card External Fault	The option received an external fault from the controller.	<ol style="list-style-type: none"> Find the device that caused the external fault and remove the caus. Clear the external fault input from the controller.
		A programming error occurred on the controller side.	Examine the operation of the controller program.
oFA00	Option Not Compatible with Port	The option connected to connector CN5-A is not compatible.	Connect the option to the correct connector. <ul style="list-style-type: none"> Use connector CN5-A when you connect the option. To use other options, refer to those option manuals.
		Invalid DIP switch S1 setting.	Set the option DIP switch S1 as shown in Figure 5.2 . Monitor, U4-75 [<i>Communication OPT Protocol</i>] will display the DIP switch S1 setting.
oFA01	Option Card Fault (CN5-A)	The option connected to option port CN5-A was changed during run.	<ol style="list-style-type: none"> De-energize the drive. Connect the option to the correct option port.
oFA03, oFA04	Option Card Error (CN5-A)	A fault occurred in the option.	<ol style="list-style-type: none"> De-energize the drive. Make sure that the option is correctly connected to the connector. If the problem continues, replace the option.
oFA30 to oFA43	Option Card Connection Error (CN5-A)	A fault occurred in the option.	<ol style="list-style-type: none"> De-energize the drive. Make sure that the option is correctly connected to the connector. If the problem continues, replace the option.
oFb00	Option Not Compatible with Port	The option connected to connector CN5-B is not compatible.	Connect the option to the correct connector. <ul style="list-style-type: none"> Use connector CN5-A when you connect the option. To use other options, refer to those option manuals.
oFb02	Option Fault	An option of the same type is already installed in option port CN5-A, CN5-B, or CN5-C.	Connect the option to the correct option port.
oFC00	Option Fault (CN5-B)	The option connected to connector CN5-C is not compatible.	Connect the option to the correct connector. <ul style="list-style-type: none"> Use connector CN5-A when you connect the option. To use other options, refer to those option manuals.
oFC02	Option Fault	An option of the same type is already installed in option port CN5-A, CN5-B, or CN5-C.	Connect the option to the correct option port.
PSE	JOHB-SMP3 Protocol Set Error	Invalid DIP switch S1 setting.	Set the option DIP switch S1 as shown in Figure 5.2 . Monitor, U4-75 [<i>Communication OPT Protocol</i>] will display the DIP switch S1 setting.

■ Minor Faults and Alarms

This section gives information about the causes and possible solutions when a minor fault or alarm occurs. Use the information in this table to remove the cause of the fault.

Code	Name	Causes	Possible Solutions
CyPo	Cycle Power to Active Parameters	Comm. Option Parameter Not Upgraded	Re-energize the drive to update the communication option parameters.

■ bUS Fault Tolerance

bUS Fault Auto-Restart

Parameter *F6-14* [*BUS Error Auto Reset*] will appear when the option is installed.

Setting *F6-14* = 0 [*Disabled*] or *F6-01* = 3, 4, 5 [*Alarm Only, Alarm (Run at d1-04), Alarm - Ramp Stop*] will not affect standard default drive behavior.

Setting *F6-14* = 1 [*Enabled*] AND *F6-01* = 0, 1, 2 [*Ramp to Stop, Coast to Stop, Fast Stop (Use C1-09)*] will cause the following operation:

- bUS [Option Communication Error]
- Then the option throws a *bUS* fault to the drive.

3. When the condition is removed, the option commands a fault reset and returns control of the drive to the EtherCAT network.

Note:

The option will only read parameter *F6-01* and *F6-14* from the drive during power-up.

◆ Option Board Error Management

This section describes the errors that the option board manages and also gives possible solutions.

Option Error	Description	Error Indication	Possible Solution
OP > SAFEOP/ PREOP when Drive running	An EtherCAT state transition from OP > SAFEOP/PREOP was made when the drive was in OPERATION enabled.	The drive triggered a <i>bUS</i> [Option Communication Error] Error. When the EtherCAT state transitions to OP while the drive is stopped, the drive error will clear.	Check and correct state machine transitions in control word.
OP > SAFEOP EtherCAT WD time out	If the EtherCAT watchdog time out is enabled (Default in native XML description file) and output data from PLC to the drive does not update in the necessary time, it will trigger an error.	The drive triggered a <i>bUS</i> Error. When the EtherCAT state transitions to OP while the drive is stopped, the drive error will clear.	<ul style="list-style-type: none"> Check network connection (for example, make sure that the cables are plugged into each node). Check telegram timing. Determine whether telegrams were sent to the slave where the error occurred.
OP > SAFEOP 1. Drive FCS error 2. Drive COMID error	<ol style="list-style-type: none"> Drive detected a Sum check error. Drive detected a Communication Option ID error. Possible cause: <ol style="list-style-type: none"> Option system is overloaded. Option is not correctly processing the state. 	<ol style="list-style-type: none"> Drive fault: <i>oFx32</i> [SUM Check Error] Drive fault: <i>oFx30</i> [COM ID Error] 	1 + 2 actions: <ul style="list-style-type: none"> Disable process data OUT sync manager channel. Force EtherCAT state change to SAFE_OP.
OP > SAFEOP 1. Option card FCS error 2. Option card COMID error	<ol style="list-style-type: none"> Option detected a Sum check error. Option detected a Communication Option ID error. Possible cause: <ol style="list-style-type: none"> Drive system is overloaded. Drive is not correctly processing the state. 	<ol style="list-style-type: none"> Drive fault: <i>oFx32</i> Drive fault: <i>oFx30</i> 	1 + 2 actions: <ul style="list-style-type: none"> Disable process data IN sync manager channel. Force EtherCAT state change to SAFE_OP.
Initial power-up sequence not completed within 10 seconds.	Possible cause: <ol style="list-style-type: none"> Drive is not processing the internal interface protocol. Drive does not support this communication option. 	Drive fault: <i>oFx00</i> [Option Not Compatible with Port] Option will log FATAL event record in NVS memory and set ERR LED: solid RED.	Actions: <ul style="list-style-type: none"> Check drive firmware version. If the drive firmware version is correct, replace option. Replace the drive.
I/F proc time out	Option has not processed any drive system frames in 1000 ms. Possible cause: Drive stopped serving the internal interface to option or HW failure.	Drive fault: <i>oFx00</i> Option will log FATAL event record in NVS memory and set ERR LED: solid RED.	Force communication state to INIT
Option ID Error: Power-up sequence copyright string mismatch.	Drive reported invalid copyright string in power-up process.	Drive fault: <i>oFx00</i> Option will log FATAL event record in NVS memory and set ERR LED: solid RED.	Replace option.

◆ Option Error Codes

■ Option Fault Monitors *U6-98* and *U6-99*

The option can declare error/warning conditions via drive monitor parameters on the drive keypad as shown in [Table 11.3](#).

Table 11.3 Option Fault Monitor Descriptions

Status	Fault Declared	Status Value (<i>U6-98/U6-99</i>)	Description
No faults	-	0	No faults
Default MAC Address	-	1103	MAC Address programmed into the option is not factory default setting. Note: Contact Yaskawa or your nearest sales representative for more information.
Web Interface Setting Error	-	1110	Failure to read the web interface setting.

Two drive monitor parameters, *U6-98* [First Fault] and *U6-99* [Current Fault] assist the user in network troubleshooting.

- U6-98* displays the first declared fault since the last power cycle. *U6-98* is only cleared upon drive power-up.

- *U6-99* displays the present option status. *U6-99* is cleared upon a network-issued fault reset and upon power-up. If another fault occurs while the original fault is still active, parameter *U6-98* retains the original fault value and *U6-99* stores the new fault status value.

◆ Self RAM Check

Use these procedures to do a self RAM check for all areas including unused areas.

Note:

- The self RAM check completes in approximately 2.5 minutes.
- When you start the self RAM check, the drive will detect *oFA00* [Option Not Compatible with Port].

1. Set DIP switches as shown in [Figure 11.1](#).

Note:

- Set DIP switch S1 to de-energize the option.
- Use non-conductive tweezers or a tool with a tip width of approximately 0.5 mm (0.02 in) to set DIP switch S1.

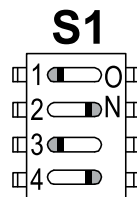

Figure 11.1 DIP Switch S1 Settings for the Self RAM Check

2. Apply power to the option. This will start the self RAM check.
3. Look at the LEDs on the option to see the status of the self RAM check. Refer to [Table 11.4](#) for more information.

Table 11.4 LED States during Self RAM Check

Self RAM Check Status	LED States	
	MS	NS
Checking	Lit in green	OFF
Successful termination	Lit in green	Lit in green
Abnormal termination	Lit in red	Lit in red

12 European Standards



Figure 12.1 CE Mark

The CE mark indicates compliance with European safety and environmental regulations.

European standards include the Machinery Directive for machine manufacturers, the Low Voltage Directive for electronics manufacturers, and the EMC Directive for controlling noise.

It is required for engaging in business and commerce in Europe.

This option displays the CE mark based on the EMC guidelines.

EMC Directive: 2014/30/EU

Drives used in combination with this option and devices used in combination with the drive must also be CE certified and display the CE mark.

When using drives displaying the CE mark in combination with other devices, it is ultimately the responsibility of the user to ensure compliance with CE standards. Verify that conditions meet European standards after setting up the device.

◆ EMC Directive Compliance

This option is tested according to European standard EN 61800-3:2004/A1:2012 and complies with the EMC Directive. The CE marking is declared based on the harmonized standards.

■ Option Installation

Verify the following installation conditions to make sure that other devices and machinery used with this option and drive also comply with EMC Directive:

1. Use dedicated shield cable for the option and external device (encoder, I/O device, master), or run the wiring through a metal conduit.
2. Keep wiring as short as possible and ground the largest possible surface area of the shield to the metal panel according to [Figure 12.2](#) and [Figure 12.3](#).

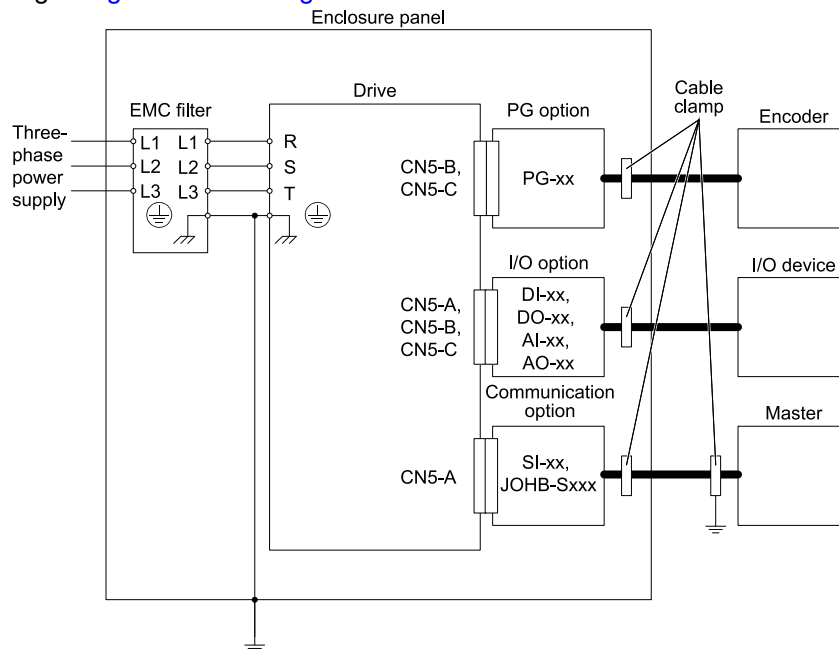

Figure 12.2 Option Installation for CE Compliance: 1000-Series, GA700, GA800, CR700

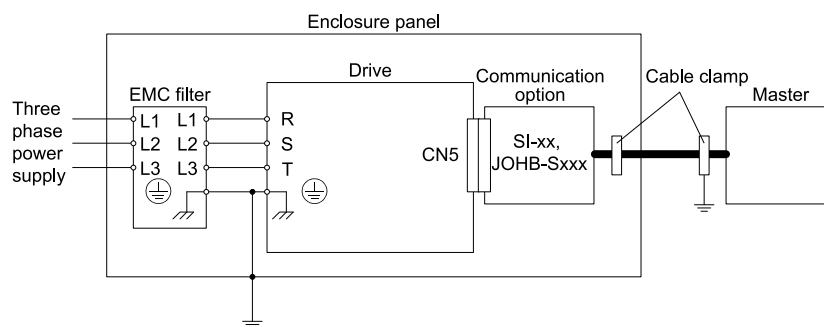
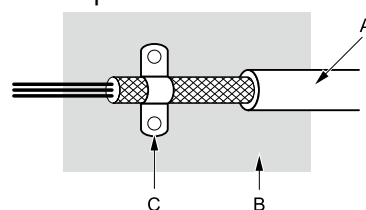

Figure 12.3 Option Installation for CE Compliance: GA500

3. Ground the largest possible surface area of the shield to the metal panel. Yaskawa recommends using cable clamps.



A - Braided shield cable
B - Metal panel

C - Cable clamp (conductive)

Figure 12.4 Ground Area

13 Specifications

◆ Specifications

Table 13.1 Option Specifications

Items	Specifications
Model	JOHB-SMP3
Communication Profile	DS 301 Ver.4.02 DSP 402 Ver.1.1 Velocity Mode
Connector	RJ45 connector
Communication Speed	100 Mbps
Ambient Temperature	-10 °C to +50 °C (14 °F to +122 °F)
Humidity	Up to 95% RH (non-condensing)
Storage Temperature	-20 °C to +60 °C (-4 °F to +140 °F) allowed for short-term transport of the product
Area of Use	Indoors and not near: <ul style="list-style-type: none"> • Oil mist, corrosive gas, flammable gas, or dust • Radioactive materials or flammable materials, including wood • Dangerous gases or fluids • Salt • Direct sunlight • Falling objects
Altitude	Up to 1000 m (3281 ft.) Note: You can use the option at a maximum of 4000 m (13123 ft), depending on the model of the drive and the operating conditions. Refer to the drive manuals for more information.

14 Disposal

◆ Disposal Instructions

Correctly dispose of the product and packing material as specified by applicable regional, local, and municipal laws and regulations.

◆ WEEE Directive



The wheeled bin symbol on this product, its manual, or its packaging identifies that you must recycle it at the end of its product life.

You must discard the product at an applicable collection point for electrical and electronic equipment (EEE). Do not discard the product with usual waste.

Revision History

Date of Publication	Revision Number	Section	Revised Content
December 2021	1	4, 7, 8, 11	Revision: Reviewed and corrected entire documentation
August 2021	-	-	First Edition

YASKAWA AC Drive Option EtherCAT Technical Manual

DRIVE CENTER (INVERTER PLANT)

2-13-1, Nishimiyaichi, Yukuhashi, Fukuoka, 824-8511, Japan
Phone: +81-930-25-2548 Fax: +81-930-25-3431
www.yaskawa.co.jp

YASKAWA ELECTRIC CORPORATION

New Pier Takeshiba South Tower, 1-16-1, Kaigan, Minatoku, Tokyo, 105-6891, Japan
Phone: +81-3-5402-4502 Fax: +81-3-5402-4580
www.yaskawa.co.jp

YASKAWA AMERICA, INC.

2121, Norman Drive South, Waukegan, IL 60085, U.S.A.
Phone: +1-800-YASKAWA (927-5292) or +1-847-887-7000 Fax: +1-847-887-7310
www.yaskawa.com

YASKAWA ELÉTRICO DO BRASIL LTDA.

777, Avenida Piraporinha, Diadema, São Paulo, 09950-000, Brasil
Phone: +55-11-3585-1100 Fax: +55-11-3585-1187
www.yaskawa.com.br

YASKAWA EUROPE GmbH

Hauptstraße 185, 65760 Eschborn, Germany
Phone: +49-6196-569-300 Fax: +49-6196-569-398
E-mail: info@yaskawa.eu.com
www.yaskawa.eu.com

YASKAWA ELECTRIC KOREA CORPORATION

35F, Three IFC, 10 Gukjegeumyung-ro, Yeongdeungpo-gu, Seoul, 07326, Korea
Phone: +82-2-784-7844 Fax: +82-2-784-8495
www.yaskawa.co.kr

YASKAWA ASIA PACIFIC PTE. LTD

30A, Kallang Place, #06-01, 339213, Singapore
Phone: +65-6282-3003 Fax: +65-6289-3003
www.yaskawa.com.sg

YASKAWA ELECTRIC (THAILAND) CO., LTD.

59, 1F-5F, Flourish Building, Soi Ratchadapisek 18, Ratchadapisek Road, Huaykwang, Bangkok, 10310, Thailand
Phone: +66-2-017-0099 Fax: +66-2-017-0799
www.yaskawa.co.th

YASKAWA ELECTRIC (CHINA) CO., LTD.

22F, Link Square 1, No.222, Hubin Road, Shanghai, 200021, China
Phone: +86-21-5385-2200 Fax: +86-21-5385-3299
www.yaskawa.com.cn

YASKAWA ELECTRIC (CHINA) CO., LTD. BEIJING OFFICE

Room 1011, Tower W3 Oriental Plaza, No. 1, East Chang An Avenue,
Dong Cheng District, Beijing, 100738, China
Phone: +86-10-8518-4086 Fax: +86-10-8518-4082

YASKAWA ELECTRIC TAIWAN CORPORATION

12F, No. 207, Section 3, Beishin Road, Shindian District, New Taipei City 23143, Taiwan
Phone: +886-2-8913-1333 Fax: +886-2-8913-1513 or +886-2-8913-1519
www.yaskawa.com.tw

YASKAWA INDIA PRIVATE LIMITED

#17/A, Electronics City, Hosur Road, Bengaluru, 560 100 (Karnataka), India
Phone: +91-80-4244-1900 Fax: +91-80-4244-1901
www.yaskawaindia.in

YASKAWA

YASKAWA ELECTRIC
CORPORATION

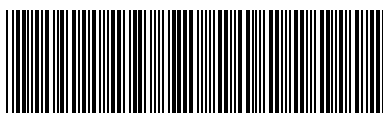

SIEPC7306000L

In the event that the end user of this product is to be the military and said product is to be employed in any weapons systems or the manufacture thereof, the export will fall under the relevant regulations as stipulated in the Foreign Exchange and Foreign Trade Regulations. Therefore, be sure to follow all procedures and submit all relevant documentation according to any and all rules, regulations and laws that may apply.

Specifications are subject to change without notice for ongoing product modifications and improvements.

© 2021 YASKAWA ELECTRIC CORPORATION

MANUAL NO. SIEP C730600 0LB <1>-0
Published in Japan December 2021
20-2-22
Original Instructions