

YASKAWA AC Drive Option

EtherNet/IP

Technical Manual

Model JOHB-SMP3

To correctly use the product, read this manual thoroughly and keep it for easy reference, inspection, and maintenance.
Make sure that the end user receives this manual.

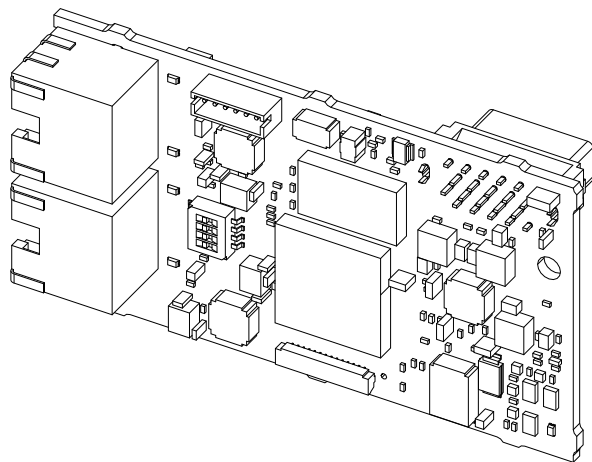

This Page Intentionally Blank

Table of Contents

1. Preface and Safety	8
Applicable Documentation	8
Glossary	8
Registered Trademarks	8
Supplemental Safety Information	8
Section Safety	9
2. Overview	9
Compatible Products	9
For Yaskawa Customers in the North or South America Regions	10
Install the Option on a GA500 Drive	10
3. Receiving	11
Option Package Contents	11
Installation Tools	12
4. Option Components	13
Option PCB Components	13
Communication Connector	13
Option LED States	13
Power-Up Diagnostics	14
5. Installation Procedure	14
Section Safety	14
Settings for the DIP Switch S1	15
Procedures to Install and Wire Options on a Drive	15
Procedure A	16
Procedure B	17
Procedure C	19
Procedure D	20
IGMP Snooping	22
Communication Cable Specifications	22
Option Connection Diagram	23
Communication Topology Specifications	23
EDS Files	24
6. Related Drive Parameters	24
7. EtherNet/IP Configuring Messaging	30
Drive Polled Configuration	30
Converter Polled Configuration	30

8. Output Assemblies (Drive Consumes)	31
EtherNet/IP Basic Speed Control Output - 20 (0x14)	31
EtherNet/IP Extended Speed Control Output - 21 (0x15)	32
EtherNet/IP Speed and Torque Control Output - 22 (0x16)	32
EtherNet/IP Extended Speed and Torque Control Output - 23 (0x17)	33
MEMOBUS/Modbus Message Output (Vendor Specific Yaskawa Electric (YE) Assy) - 100 (0x64)	33
(Vendor Specific Yaskawa Electric (YE) Assy) Speed/Torque Control Output - 101 (0x65)	34
(Vendor Specific Yaskawa Electric (YE) Assy) Extended Speed/Torque Control Output - 115 (0x73)	35
(Vendor Specific Yaskawa Electric (YE) Assy)-High Speed/Torque Control Output - 116 (0x74)	37
(Vendor Specific Yaskawa Electric (YE) Assy) 8 Byte Dynamic Output - 117 (0x75)	39
(Vendor Specific Yaskawa Electric (YE) Assy) 12 Byte Dynamic Output - 118 (0x76)	40
(Vendor Specific Yaskawa Electric (YE) Assy) 18 Byte Dynamic Output - 119 (0x77)	41
(Vendor Specific Yaskawa Electric (YE) Assy) 24 Byte Dynamic Output - 120 (0x78)	42
(Vendor Specific Yaskawa Electric (YE) Assy) Gateway Consume Assembly - 130 (0x82)	44
9. Input Assemblies (Drive Produces)	45
EtherNet/IP Basic Speed Control Input - 70 (0x46)	45
EtherNet/IP Extended Speed Control Input - 71 (0x47)	45
EtherNet/IP Speed and Torque Control Input - 72 (0x48)	46
EtherNet/IP Extended Speed and Torque Control Input - 73 (0x49)	47
(Vendor Specific Yaskawa Electric (YE) Assy) MEMOBUS/Modbus Message Input - 150 (0x96)	47
(Vendor Specific Yaskawa Electric (YE) Assy) Speed/Torque Status Input - 151 (0x97)	48
(Vendor Specific Yaskawa Electric (YE) Assy) Extended Speed/Torque Status Input - 155 (0x9B)	50
(Vendor Specific Yaskawa Electric (YE) Assy) High Speed/Torque Status Input - 166 (0xA6)	52
(Vendor Specific Yaskawa Electric (YE) Assy) 8-Byte Dynamic Input - 167 (0xA7)	55
(Vendor Specific Yaskawa Electric (YE) Assy) 12-Byte Dynamic Input - 168 (0xA8)	56
(Vendor Specific Yaskawa Electric (YE) Assy) 18-Byte Dynamic Input - 169 (0xA9)	58
(Vendor Specific Yaskawa Electric (YE) Assy) 24-Byte Dynamic Input - 170 (0xAA)	59
(Vendor Specific Yaskawa Electric (YE) Assy) Gateway Produce Assembly - 180 (0xB4)	60
10. Output Assemblies (Converter Consumes)	61
EtherNet/IP Basic Speed Control Output - 20 (0x14)	62
EtherNet/IP Extended Speed Control Output - 21 (0x15)	62
EtherNet/IP Speed and Torque Control Output - 22 (0x16)	63
EtherNet/IP Extended Speed and Torque Control Output - 23 (0x17)	63
(Vendor Specific Yaskawa Electric (YE) Assy) Speed/Torque Control Output - 101 (0x65)	64
(Vendor Specific Yaskawa Electric (YE) Assy) Extended Speed/Torque Control Output - 115 (0x73)	65

(Vendor Specific Yaskawa Electric (YE) Assy)-High Speed/Torque Control Output - 116 (0x74)	67
(Vendor Specific Yaskawa Electric (YE) Assy) 8 Byte Dynamic 2 Output - 117 (0x75).....	69
(Vendor Specific Yaskawa Electric (YE) Assy) 12 Byte Dynamic 4 Output - 118 (0x76).....	70
(Vendor Specific Yaskawa Electric (YE) Assy) 18 Byte Dynamic 7 Output - 119 (0x77).....	71
(Vendor Specific Yaskawa Electric (YE) Assy) 24 Byte Dynamic 10 Output - 120 (0x78).....	73
11. Input Assemblies (Converter Produces)	74
EtherNet/IP Basic Speed Control Input - 70 (0x46).....	74
EtherNet/IP Extended Speed Control Input - 71 (0x47)	74
EtherNet/IP Speed and Torque Control Input - 72 (0x48).....	75
EtherNet/IP Extended Speed and Torque Control Input - 73 (0x49)	75
(Vendor Specific Yaskawa Electric (YE) Assy) Speed/Torque Status Input - 151 (0x97).....	76
(Vendor Specific Yaskawa Electric (YE) Assy) Extended Speed/Torque Status Input - 155 (0x9B)	77
(Vendor Specific Yaskawa Electric (YE) Assy) High Speed/Torque Status Input - 166 (0xA6).....	79
(Vendor Specific Yaskawa Electric (YE) Assy) 8-Byte Dynamic Input 2 - 167 (0xA7) ...	82
(Vendor Specific Yaskawa Electric (YE) Assy) 12-Byte Dynamic Input 4 - 168 (0xA8).....	84
(Vendor Specific Yaskawa Electric (YE) Assy) 18-Byte Dynamic Input 7 - 169 (0xA9).....	85
(Vendor Specific Yaskawa Electric (YE) Assy) 24-Byte Dynamic Input 10 - 170 (0xAA)	86
12. General Class Objects (Drive)	88
Identity Object - 1 (Class 0x01)	88
Services Supported	88
Attributes Supported	88
Assembly Object - 4 (Class 0x04)	89
Services Supported	89
Attributes Supported	89
Motor Data Object - 40 (Class 0x28)	90
Services Supported	90
Attributes Supported	90
Control Supervisor Object - 41 (Class 0x29).....	91
Services Supported	91
Attributes Supported	91
Option Fault Code Conversion Table	92
AC/DC Drive Object - 42 (Class 0x2A)	93
Services Supported	93
Attributes Supported	94
Base Energy Object 78 (Class 0x4E).....	95
Services Supported	95
Attributes Supported	95
Electrical Energy Object 79 (Class 0x4F)	96
Services Supported	96

Attributes Supported	96
TCP/IP Object 245 (Class 0xF5)	96
Services Supported	96
Attributes Supported	96
Ethernet Link Object 246 (Class 0xF6)	97
Services Supported	97
Attributes Supported	97
13. General Class Objects (Converter)	99
Motor Data Object - 40 (Class 0x28)	99
Services Supported	99
Attributes Supported	100
Control Supervisor Object 41 (Class 0x29)	100
Services Supported	100
Attributes Supported	100
AC/DC Drive Object - 42 (Class 0x2A)	101
Services Supported	101
Attributes Supported	101
Base Energy Object 78 (Class 0x4E)	102
Services Supported	102
Attributes Supported	102
Electrical Energy Object 79 (Class 0x4F)	103
Services Supported	103
Attributes Supported	103
14. Vendor-Specific (Yaskawa) Class Objects	103
Yaskawa Drive Parameters Object - 100 (Class 0x64)	103
Services Supported	103
Storing Changed Parameters	104
Attributes Supported	104
Yaskawa Monitor/Control Object - 125 (Class 0x7D)	104
Services Supported	104
Attributes Supported	105
15. Web Interface	105
Home Page	105
EtherNet/IP Page	106
Network Page	106
Chart Page	107
Email Alerts Page	107
Parameter Access Page	108
Settings Page	108
16. Troubleshooting	108
Drive-Side Error Codes	108
Faults	108
Minor Faults and Alarms	109
bUS Fault Tolerance	110
bUS Fault Auto-Restart	110
bUS Fault Delay	110
Explicit Message Communications Errors	110
Option Error Codes	110
Option Fault Monitors <i>U6-98</i> and <i>U6-99</i>	110

Self RAM Check	111
17. European Standards	111
EMC Directive Compliance	112
Option Installation	112
18. Specifications	113
Specifications	113
19. Disposal	114
Disposal Instructions	114
WEEE Directive	114
Revision History	115

1 Preface and Safety

YASKAWA Electric supplies component parts for use in a wide variety of industrial applications. The selection and application of YASKAWA products remain the responsibility of the equipment designer or end user.

YASKAWA accepts no responsibility for the way its products are incorporated into the final system design. Under no circumstances should any YASKAWA product be incorporated into any product or design as the exclusive or sole safety control. Without exception, all controls should be designed to detect faults dynamically and fail safely under all circumstances. All products designed to incorporate a component part manufactured by YASKAWA must be supplied to the end user with appropriate warnings and instructions as to the safe use and operation of that part. Any warnings provided by YASKAWA must be promptly provided to the end user. YASKAWA offers an express warranty only as to the quality of its products in conforming to standards and specifications published in the manual. **NO OTHER WARRANTY, EXPRESS OR IMPLIED, IS OFFERED.** YASKAWA assumes no liability for any personal injury, property damage, losses, or claims arising from misapplication of its products.

◆ Applicable Documentation

Document	Description
JOHB-SMP3 Multi-Protocol EtherNet Quick Setup Procedure Document No. TOBP C730600 0H	Read this manual first. The manual provides information about wiring, settings, functions, and troubleshooting. The manual is packaged together with the product.
YASKAWA AC Drive Option EtherNet/IP Technical Manual Document No. SIEP C730600 0J (This book)	The technical manual contains detailed information about the option. Access the following sites to obtain the technical manual: U.S.: http://www.yaskawa.com Europe: http://www.yaskawa.eu.com Japan: http://www.e-mechatronics.com Other areas: Check the back cover of these manuals. For questions, contact Yaskawa or a Yaskawa representative.
YASKAWA AC Drive Manuals	Refer to the drive manual to connect with the option. Drive manuals contain basic installation and wiring information in addition to detailed parameter setting, fault diagnostic, and maintenance information. The manuals also include important information about parameter settings and tuning the drive. The Quick Start Guides are packaged with the drive. The most recent versions of these manuals are available for download on our documentation websites: U.S.: http://www.yaskawa.com Europe: http://www.yaskawa.eu.com Japan: http://www.e-mechatronics.com Other areas: Check the back cover of these manuals. For questions, contact Yaskawa or a Yaskawa representative.

◆ Glossary

Terms	Definition
Option	YASKAWA AC Drive Option JOHB-SMP3 with DIP switches set for EtherNet/IP
Keypad	<ul style="list-style-type: none"> • HOA Operator • LCD Operator • LED Operator • HOA Keypad • LCD Keypad • LED Keypad
Hex. (Example: 900 (Hex.))	Identifies a unit for hexadecimal number format.

◆ Registered Trademarks

- EtherNet/IP is a registered trademark of Open DeviceNet Vendor Association, Inc. (ODVA).
- Trademarks are the property of their respective owners.

◆ Supplemental Safety Information

Read and understand this manual before installing, operating, or servicing this option. The option must be installed according to this manual and local codes.

The following conventions are used to indicate safety messages in this manual. Failure to heed these messages could result in serious or possibly even fatal injury or damage to the products or to related equipment and systems.

⚠ DANGER This signal word identifies a hazard that will cause serious injury or death if you do not prevent it.

⚠ WARNING This signal word identifies a hazard that can cause death or serious injuries if you do not prevent it.

⚠ CAUTION This signal word identifies a hazardous situation, which, if not avoided, can cause minor or moderate injury.

NOTICE This signal word identifies a property damage message that is not related to personal injury.

■ Section Safety

General Precautions

- The diagrams in this section may include options and drives without covers or safety shields to illustrate details. Be sure to reinstall covers or shields before operating any devices. The option should be used according to the instructions described in this manual.
- The diagrams in this manual are provided as examples only and may not pertain to all products covered by this manual.
- The products and specifications described in this manual or the content and presentation of the manual may be changed without notice to improve the product and/or the manual.
- Contact Yaskawa or a Yaskawa representative and provide the manual number shown on the front cover to order new copies of the manual.

⚠ DANGER Do not ignore the safety messages in this manual. If you ignore the safety messages in this manual, it will cause serious injury or death. The manufacturer is not responsible for injuries or damage to equipment.

⚠ WARNING Electrical Shock Hazard. Do not modify the drive or option circuitry. Failure to obey can cause serious injury or death, or cause damage to the drive or option and will void warranty. Yaskawa is not responsible for modifications of the product made by the user.

NOTICE Damage to Equipment. Do not use steam or other disinfectants to fumigate wood for packaging the drive. Use alternative methods, for example heat treatment, before you package the components. Gas from wood packaging fumigated with halogen disinfectants, for example fluorine, chlorine, bromine, iodine or DOP gas (phthalic acid ester), can cause damage to the drive.

2 Overview

This option provides a communications connection between the drive and an EtherNet/IP network. The option connects the drive to an EtherNet/IP network and facilitates the exchange of data.

EtherNet/IP is a communications link to connect industrial devices (for example smart motor controllers, operator interfaces, and variable frequency drives) and control devices (for example, programmable controllers and computers) to a network. EtherNet/IP is a simple networking solution. EtherNet/IP decreases the cost and time to wire and install factory automation devices, and it gives the option to interchange like components from other vendors.

EtherNet/IP is an open network standard.

Install the option on a drive to perform the following functions from an EtherNet/IP client:

- Operate the drive
- Monitor the drive operation status
- Change drive parameter settings

◆ Compatible Products

You can use the option with these products:

Table 2.1 Compatible Products

Product Series	Model(s)	Software Version ^{*1}
A1000	CIMR-Ax2Axxxx	≥ 1020
	CIMR-Ax4A0002 - 4A0675	
	CIMR-Ax4A0930, 4A1200	≥ 3015
	CIMR-Ax5Axxxx	≥ 5040 ≥ 1017
D1000	CIMR-Dx2A0005 - 4A0370	≥ 2006
	CIMR-Dx4A0630	≥ 3014
R1000	CIMR-Rx2A03P5 - 4A0300	≥ 2102
U1000	CIMR-UxxAxxxx	≥ 1015
	CIMR-UxxExxxx	

Product Series	Model(s)	Software Version ^{*1}
	CIMR-UxxPxxxx	
	CIMR-UxxWxxxx	
Z1000	CIMR-ZxxAxxxx	≥ 1016
Z1000U	CIMR-ZxxUxxxx	≥ 6113
	CIMR-ZxxExxxxx	
	CIMR-ZxxPxxxx	
	CIMR-ZxxWxxxx	
CR700	CIPR-CR70xxxxx	≥ 1012
GA500	CIPR-GA50xxxxx	≥ 1010
GA700	CIPR-GA70xxxxx	≥ 1010
GA800	CIPR-GA80xxxxx	≥ 9010
HV600	CIPR-HV60xxxxx	≥ 1011
FP605	CIPR-FP65xxxxx	≥ 1010

*1 Refer to "PRG" on the drive nameplate for the software version number.

Note:

Refer to the option package labeling in the field designated "PRG (four digit number)" to identify the option software version.

■ For Yaskawa Customers in the North or South America Regions

If your drive series is not shown in the "Compatible Products" section, refer to the web page below to confirm that your drive is compatible with this option. The web page shows a list of drives and compatible options, and also directs you to the correct installation manual and installation procedure for your drive.

Refer to the URL or scan QR code:



<https://www.yaskawa.com/mpe>

◆ Install the Option on a GA500 Drive

An option card mounting kit is necessary to install the option on a GA500 drive. The option card mounting kit model is: JOHB-GA50. This kit is sold separately.

Refer to the option card mounting kit manual for more information about installation.

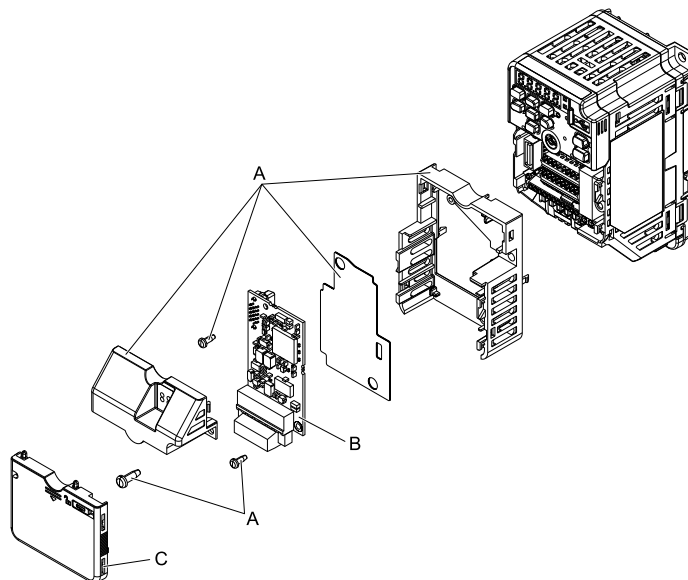

A - Option card mounting kit components (sold separately)
 B - Option
 C - Drive front cover

Figure 2.1 Option Card Mounting Kit (JOHB-GA50)

3 Receiving

After you receive the option package:



- Make sure that there is no damage to the option and no parts are missing. The Yaskawa warranty does not include damage from shipping. If there is damage to the option or other parts, contact the shipping company immediately.

NOTICE *Damage to Equipment. Do not use damaged parts to connect the drive and the option. Failure to comply could damage the drive and option.*

- Make sure that the model number on the option nameplate and the model number on the purchase order are the same. Refer to Figure 4.1 for more information.
- Contact the distributor where you purchased the option or contact Yaskawa or a Yaskawa representative about any problems with the option.

◆ Option Package Contents

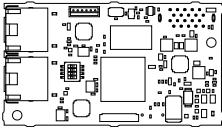
Table 3.1 Contents of Package

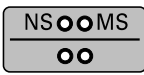
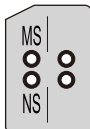
Option Contents		Quantity
Option		1
Ground Wire *1		1
Screws (M3)		3 *2
LED Labels *3	1000-Series, Z1000U 	1
	GA500, GA700, GA800, CR700 	1

3 Receiving

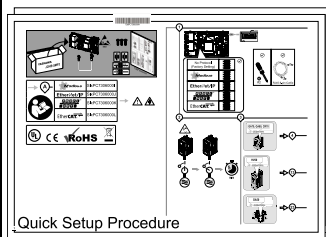
Option Contents		Quantity
	Z1000, HV600, FP605 *4	1
Quick Setup Procedure		1

- *1 GA500, GA700, GA800, and CR700 drives do not use the ground wire.
- *2 GA700, GA800, CR700, HV600, and FP605 drives use two screws only.
- *3 LED labels are located on this label sheet.

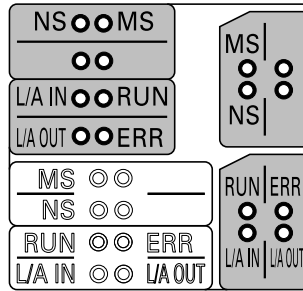

Figure 3.1 LED Label Sheet

- *4 The LED label has transparent background and white letters. Please make sure that you use the correct label for Z1000, HV600, or FP605.

◆ Installation Tools

You can use these tools to install the option to the drive:

- A Phillips screwdriver or slotted screwdriver *1.
- Non-conductive tweezers or a tool with a tip width of approximately 0.5 mm (0.02 in) to set DIP switch S1.
- A pair of diagonal cutting pliers.
- A small file or medium-grit sandpaper.

- *1 Phillips screw sizes are different for different drive capacities. Prepare different screwdrivers for different screw sizes.

4 Option Components

◆ Option PCB Components

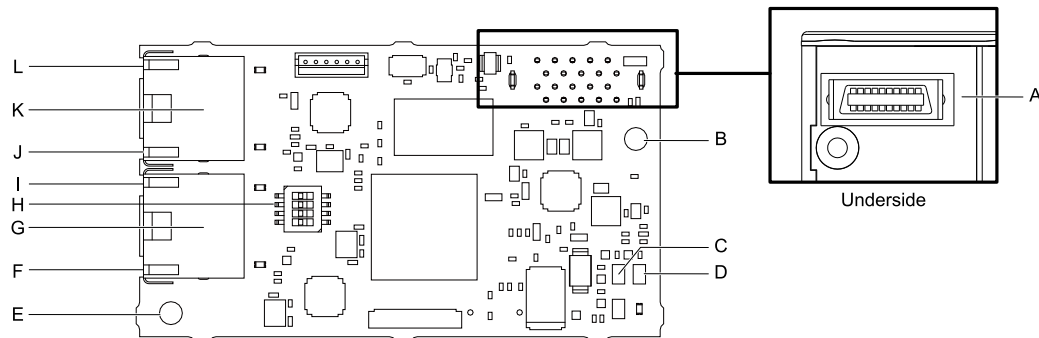

- | | |
|--|--|
| A - Connector (CN5) | G - Option modular connector CN1B (Port 2) (RJ45) |
| B - Installation hole | H - DIP switch S1 |
| C - LED (NS) *1 | I - Port 2 LED (LINK/ACT) *1 |
| D - LED (MS) *1 | J - Port 1 LED (10/100) *1 |
| E - Ground terminal (FE) and installation hole *2 | K - Option modular connector CN1A (Port 1) (RJ45) |
| F - Port 2 LED (10/100) *1 | L - Port 1 LED (LINK/ACT) *1 |

Figure 4.1 Option PCB Components

*1 Refer to [Option LED States on page 13](#) for more information about the LEDs.

*2 Connect the included ground wire during installation. The ground wire is not necessary for installation on GA700, GA800, and CR700 drives. For GA500 drives, connect the included ground wire to the separately-sold communication option case (model: JOHB-GA50).

◆ Communication Connector

Option connections CN1A (Port 1) and CN1B (Port 2) are connection points for customer-supplied EtherNet/IP network communication cables. These ports accept customer-supplied male 8-way ethernet modular RJ45 connectors.

Table 4.1 Male 8-way Ethernet Modular Connector (Customer-Supplied)

Male 8-way Ethernet Modular Connector	Pin	Description
	1 (Pair 2)	Transmit data (TXD) +
	2 (Pair 2)	Transmit data (TXD) -
	3 (Pair 3)	Receive data (RXD) +
	4 (Pair 1)	Not used
	5 (Pair 1)	Not used
	6 (Pair 3)	Receive data (RXD) -
	7 (Pair 4)	Not used
	8 (Pair 4)	Not used

◆ Option LED States

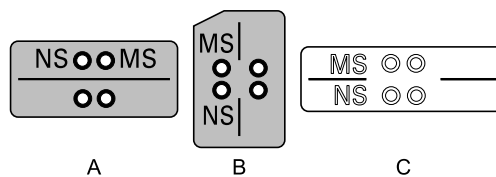

A - 1000-Series, Z1000U

B - GA500, GA700, GA800, CR700

C - Z1000, HV600, FP605 *1

Figure 4.2 Option LED Labels

*1 LED label has transparent background and white letters. Please make sure that you use the correct label for Z1000, HV600, or FP605.

Wait 2 seconds minimum for the power-up diagnostic process to complete before you verify the LED states. [Table 4.2](#) shows the operating status of the option LEDs after the power-up diagnostic LED sequence is complete.

Table 4.2 Option LED States

LED Name	Indication		Operating State	Description
	Color	State		
MS (Module Status)	-	OFF	Power supply off	There is no power to the drive.
	Green	ON	Option operating	The option is operating normally.
	Green	Flashing	Option initializing	The option is configuring an IP address.
	Red	ON	Fatal error occurred	The option detected a fatal (unrecoverable) error.
	Red	Flashing	Non-fatal error occurred	The option detected a non-fatal (recoverable) error.
NS (Network Status)	-	OFF	Power supply OFF or Offline	-
	Green	ON	Online communications established	The option is online and has established connections.
	Green	Flashing	Online with IP address	The option is configured with an active link but does not have any control connections.
	Red	ON	Communications error (fatal)	The option detected a duplicate IP address.
10/100 */	-	OFF	10 Mbps is established	-
	Green	ON	100 Mbps is established	
LINK/ACT */	-	OFF	Link is not established	
	Green	ON	Link is established	
	Green	Flashing	Link is established and there is network activity	

*1 To verify LED states, you must remove the drive front cover. Do not touch the drive main circuit terminal or circuit boards when you remove the drive front cover.

■ Power-Up Diagnostics

An LED test is performed each time the drive is powered up. The initial boot sequence can take several seconds. After the LEDs complete the diagnostic LED sequence, the option is successfully initialized. The LEDs then assume operational conditions as shown in [Table 4.3](#).

Table 4.3 Power-Up Diagnostic LED Sequence

Sequence	Module Status (MS)	Network Status (NS)	Time (ms)
1	Green	OFF	250
2	Red	OFF	250
3	Green	OFF	-
4	Green	Green	250
5	Green	Red	250
6	Green	OFF	-

5 Installation Procedure

◆ Section Safety

⚠ DANGER *Electrical Shock Hazard. Do not examine, connect, or disconnect wiring on an energized drive. Before servicing, disconnect all power to the equipment and wait for the time specified on the warning label at a minimum. The internal capacitor stays charged after the drive is de-energized. The charge indicator LED extinguishes when the DC bus voltage decreases below 50 Vdc. When all indicators are OFF, measure for dangerous voltages to make sure that the drive is safe. If you do work on the drive when it is energized, it will cause serious injury or death from electrical shock.*

⚠ WARNING *Electrical Shock Hazard. Do not operate the drive when covers are missing. Replace covers and shields before you operate the drive. Use the drive only as specified by the instructions. Some figures in this section include drives without covers or safety shields to more clearly show the inside of the drive. If covers or safety shields are missing from the drive, it can cause serious injury or death.*

⚠ WARNING *Electrical Shock Hazard. Only let approved personnel install, wire, maintain, examine, replace parts, and repair the drive. If personnel are not approved, it can cause serious injury or death.*

- ⚠ WARNING** *Electrical Shock Hazard. Do not remove covers or touch circuit boards while the drive is energized. If you touch the internal components of an energized drive, it can cause serious injury or death.*
- ⚠ WARNING** *Electrical Shock Hazard. Do not use damaged wires, put too much force on the wiring, or cause damage to the wire insulation. Damaged wires can cause serious injury or death.*
- ⚠ WARNING** *Fire Hazard. Tighten all terminal screws to the correct tightening torque. Connections that are too loose or too tight can cause incorrect operation and damage to the drive. Incorrect connections can also cause death or serious injury from fire.*
- NOTICE** *Damage to Equipment. When you touch the option, make sure that you observe correct electrostatic discharge (ESD) procedures. If you do not follow procedures, it can cause ESD damage to the drive circuitry.*
- NOTICE** *Damage to Equipment. Do not de-energize the drive while the drive is outputting voltage. Incorrect equipment sequencing can cause damage to the drive.*
- NOTICE** *Do not operate a drive or connected equipment that has damaged or missing parts. You can cause damage to the drive and connected equipment.*
- NOTICE** *Use Yaskawa connection cables or recommended cables only. Incorrect cables can cause the drive or option to function incorrectly.*
- NOTICE** *Damage to Equipment. Correctly connect the connectors. Incorrect connections can cause malfunction or damage to the equipment.*
- NOTICE** *Damage to Equipment. Make sure that all connections are correct after you install the drive and connecting peripheral devices. Incorrect connections can cause damage to the option.*

◆ Settings for the DIP Switch S1

Use the DIP switch S1 on the option to select the communication protocol.
 Use non-conductive tweezers or a tool with a tip width of approximately 0.5 mm (0.02 in) to set DIP switch S1.
 Figure 5.1 shows the default settings for the DIP switch S1.

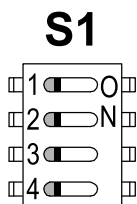

Figure 5.1 Default Settings for DIP Switch S1

When you use EtherNet/IP, set the DIP switch S1 as shown in Figure 5.2.

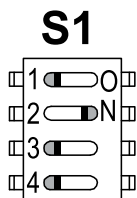

Figure 5.2 Settings for the DIP Switch S1

◆ Procedures to Install and Wire Options on a Drive

Procedures to install and wire the option are different for different drive models.
 Refer to Table 5.1 to check the procedures to install and wire the option on a drive.

Table 5.1 Procedures to Install and Wire Options on a Drive

Product Series	Procedures to Install and Wire Options on a Drive	Page
A1000	Procedure A	16
D1000	Procedure A	16
R1000	Procedure A	16
U1000	Procedure A	16
Z1000U	Procedure A	16
Z1000	Procedure B	17
GA500	*I	-

Product Series	Procedures to Install and Wire Options on a Drive	Page
GA700	Procedure C	19
GA800	Procedure C	19
CR700	Procedure C	19
HV600	Procedure D	20
FP605	Procedure D	20

*1 To install the option on GA500 drives, use the option mounting kit (JOHB-GA50) and manual.

■ Procedure A

This section shows the procedure to install and wire the option on a 1000-series drive.

Prepare the Drive for the Option

Correctly wire the drive as specified by the manual packaged with the drive. Make sure that the drive functions correctly. Refer to the drive manuals for more information.

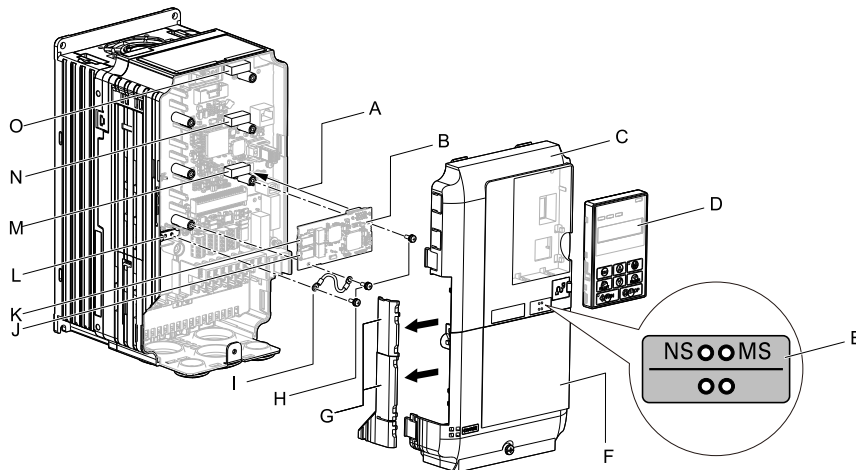

- | | |
|--|---|
| A - Insertion point for CN5 connector | I - Ground wire |
| B - Option | J - Option modular connector CN1B (Port 2) (RJ45) |
| C - Drive front cover | K - Option modular connector CN1A (Port 1) (RJ45) |
| D - Keypad | L - Drive grounding terminal (FE) |
| E - LED label | M - Connector CN5-A |
| F - Drive terminal cover | N - Connector CN5-B (Not available for communication option installation.) |
| G - Removable tabs for wire routing | O - Connector CN5-C (Not available for communication option installation.) |
| H - Included screws | |

Figure 5.3 Drive Components with Option

Install the Option

⚠ DANGER *Electrical Shock Hazard. Do not examine, connect, or disconnect wiring on an energized drive. Before servicing, disconnect all power to the equipment and wait for the time specified on the warning label at a minimum. The internal capacitor stays charged after the drive is de-energized. The charge indicator LED extinguishes when the DC bus voltage decreases below 50 Vdc. When all indicators are OFF, measure for dangerous voltages to make sure that the drive is safe. If you do work on the drive when it is energized, it will cause serious injury or death from electrical shock.*

NOTICE *Damage to Equipment. When you touch the option, make sure that you observe correct electrostatic discharge (ESD) procedures. If you do not follow procedures, it can cause ESD damage to the drive circuitry.*

Note:

You can only install this option into the CN5-A connector on the drive control board.

1. Shut off power to the drive and wait for the time specified on the drive warning label at a minimum. Make sure that the charge indicator LED is unlit, then remove the keypad and front cover. Refer to the drive manuals for more information.
2. Remove the keypad (D), front cover (C), and terminal cover (F).
3. Put the LED label (E) in the correct position on the drive front cover (C).
4. Install the option (B) into the CN5-A connector (M) on the drive and use the included screws (H) to put it in place.

5. Use one of the remaining included screws (H) to connect one end of the ground wire (I) to the ground terminal (L). Use the last remaining included screw (H) to connect the other end of the ground wire (I) to the remaining ground terminal and installation hole on the option (B).

Tighten the screws to a correct tightening torque:

- 0.5 N·m to 0.6 N·m (4.4 lbf·in to 5.3 lbf·in)

Note:

The drive has only two ground terminal screw holes. When you connect three options, two options will share one ground terminal.

6. Route the option wiring.

Procedures to wire the option are different for different drive models.

- You can route the option wiring through openings on the front cover of some models. Remove the perforated tabs on the left side of the front cover as shown in [Figure 5.4-A](#) to create the necessary openings on these models. To prevent damage to the cable from the cut end, treat the cut surface with sandpaper.

- Route the option wiring inside the enclosure as shown in [Figure 5.4-B](#).

Refer to the drive manuals for more information.

Note:

Isolate communication cables from main circuit wiring and other electrical and power lines.

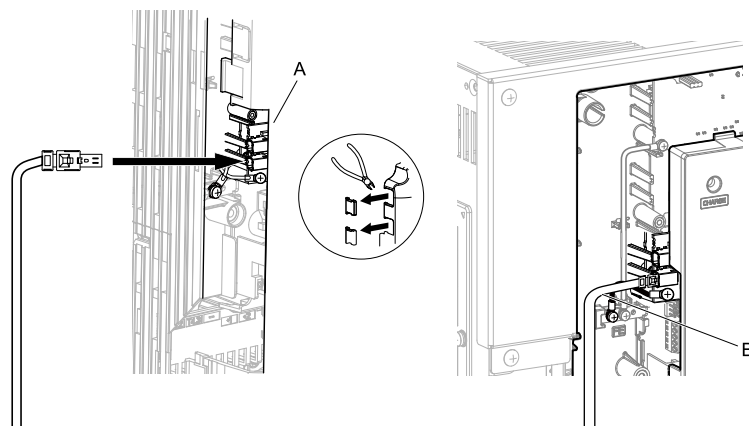

A - Route wires through the openings provided on the left side of the front cover. *1

B - Use the open space provided inside the drive to route option wiring.

Figure 5.4 Wire Routing Examples

*1 If there is wiring outside the enclosure, the drive will not meet Enclosed wall-mounted type (IP20/UL Type 1) requirements.

7. Firmly connect the Ethernet communication cables to CN1B (Port 2) (J), and/or CN1A (Port 1) (K). Isolate communication cables from main circuit wiring and other electrical and power lines. Make sure that you firmly connect the cable end. Refer to [Communication Cable Specifications on page 22](#) for more information.
8. Reattach the front cover (C), terminal cover (F), and keypad (D). Refer to the drive manuals for more information.

NOTICE Do not pinch cables between the front covers and the drive. Failure to comply could cause erroneous operation.

9. Set drive parameters in [Related Drive Parameters on page 24](#) for correct option performance.

■ Procedure B

This section shows the procedure to install and wire the option on a Z1000 drive.

Prepare the Drive for the Option

Correctly wire the drive as specified by the manual packaged with the drive. Make sure that the drive functions correctly. Refer to the drive manuals for more information.

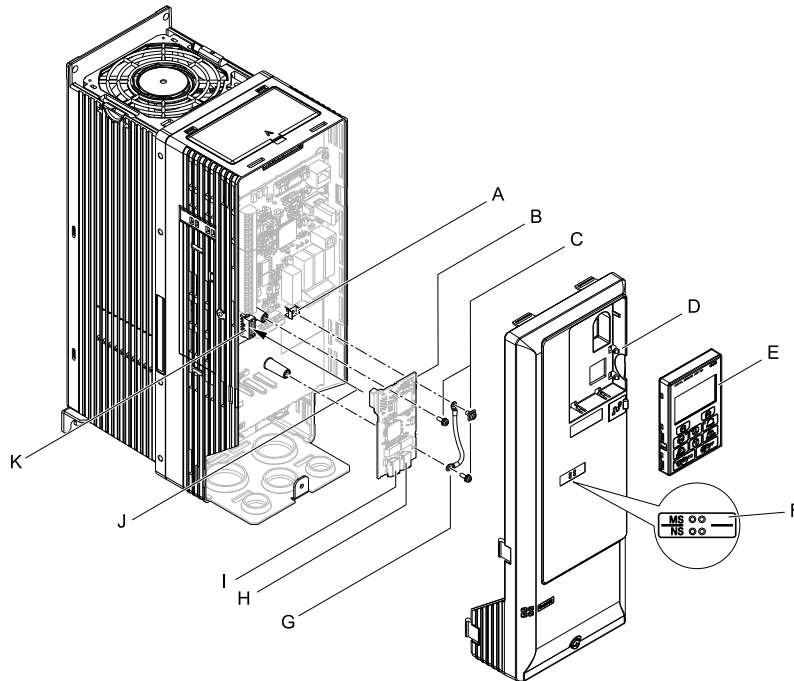

- | | |
|--|--|
| A - Drive grounding terminal (FE) | G - Ground wire |
| B - Option | H - Option modular connector CN1B (Port 2) (RJ45) |
| C - Included screws | I - Option modular connector CN1A (Port 1) (RJ45) |
| D - Drive front cover | J - Insertion point for CN5 connector |
| E - Keypad | K - Connector CN5 |
| F - LED label | |

Figure 5.5 Drive Components with Option

Install the Option

⚠ DANGER *Electrical Shock Hazard. Do not examine, connect, or disconnect wiring on an energized drive. Before servicing, disconnect all power to the equipment and wait for the time specified on the warning label at a minimum. The internal capacitor stays charged after the drive is de-energized. The charge indicator LED extinguishes when the DC bus voltage decreases below 50 Vdc. When all indicators are OFF, measure for dangerous voltages to make sure that the drive is safe. If you do work on the drive when it is energized, it will cause serious injury or death from electrical shock.*

NOTICE *Damage to Equipment. When you touch the option, make sure that you observe correct electrostatic discharge (ESD) procedures. If you do not follow procedures, it can cause ESD damage to the drive circuitry.*

- Shut off power to the drive and wait for the time specified on the drive warning label at a minimum. Make sure that the charge indicator LED is unlit, then remove the keypad and front cover. Refer to the drive manuals for more information.
- Remove the keypad (E) and front cover (D).
- Put the LED label (F) in the correct position on the drive front cover (D).
- Install the option (B) into the CN5 connector (K) on the drive and use one of the included screws (C) to put it in place.
- Use one of the remaining included screws (C) to connect one end of the ground wire (G) to the ground terminal (A). Use the last remaining included screw (C) to connect the other end of the ground wire (G) to the remaining ground terminal and installation hole on the option (B).
Tighten the screws to a correct tightening torque:
 - 0.5 N·m to 0.6 N·m (4.4 lbf·in to 5.3 lbf·in)
- Firmly connect the Ethernet communication cables to CN1B (Port 2) (H), and/or CN1A (Port 1) (I). Isolate communication cables from main circuit wiring and other electrical and power lines. Make sure that you firmly connect the cable end. Refer to [Communication Cable Specifications on page 22](#) for more information.
- Reattach the drive front cover (D) and the keypad (E). Refer to the drive manuals for more information.

NOTICE *Do not pinch cables between the front covers and the drive. Failure to comply could cause erroneous operation.*

8. Set drive parameters in [Related Drive Parameters on page 24](#) for correct option performance.

■ Procedure C

This section shows the procedure to install and wire the option on a GA700, GA800 or CR700 drive.

Prepare the Drive for the Option

Correctly wire the drive as specified by the manual packaged with the drive. Make sure that the drive functions correctly. Refer to the drive manuals for more information.

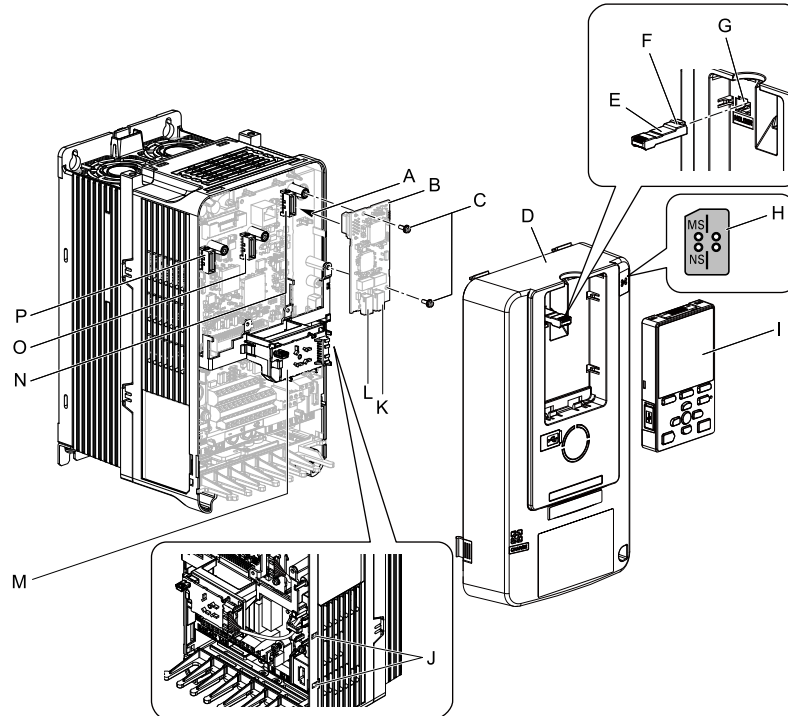

- | | |
|---------------------------------------|--|
| A - Insertion point for CN5 connector | I - Keypad |
| B - Option | J - LED Status Ring board temporary placement holes |
| C - Included screws | K - Option modular connector CN1B (Port 2) (RJ45) |
| D - Drive front cover | L - Option modular connector CN1A (Port 1) (RJ45) |
| E - Keypad connector | M - LED Status Ring board |
| F - Keypad connector tab | N - Connector CN5-A |
| G - Holder | O - Connector CN5-B (Not available for communication option installation.) |
| H - LED label | P - Connector CN5-C (Not available for communication option installation.) |

Figure 5.6 Drive Components with Option

Install the Option

⚠ DANGER *Electrical Shock Hazard. Do not examine, connect, or disconnect wiring on an energized drive. Before servicing, disconnect all power to the equipment and wait for the time specified on the warning label at a minimum. The internal capacitor stays charged after the drive is de-energized. The charge indicator LED extinguishes when the DC bus voltage decreases below 50 Vdc. When all indicators are OFF, measure for dangerous voltages to make sure that the drive is safe. If you do work on the drive when it is energized, it will cause serious injury or death from electrical shock.*

NOTICE *Damage to Equipment. When you touch the option, make sure that you observe correct electrostatic discharge (ESD) procedures. If you do not follow procedures, it can cause ESD damage to the drive circuitry.*

Note:

You can only install this option into the CN5-A connector on the drive control board.

1. Put the LED label (H) in the correct position on the drive front cover (D).
2. Shut off power to the drive and wait for the time specified on the drive warning label at a minimum. Make sure that the charge indicator LED is unlit, then remove the keypad and front cover. Refer to the drive manuals for more information.

3. Remove the keypad (I) and front cover (D).

Note:

Remove the keypad, then move the keypad connector (E) to the holder (G) on the drive, then remove the front cover.

4. Carefully remove the LED Status Ring board (M) and put it in the temporary placement holes (J) on the right side of the drive.

Refer to the drive manuals for more information.

NOTICE Do not remove the LED Status Ring board cable connector. If you disconnect the LED Status Ring board, it can cause incorrect operation and damage to the drive.

5. Install the option (B) into the CN5-A connector (N) on the drive and use the included screws (C) to put it in place.

Tighten the screws to a correct tightening torque:

- 0.5 N·m to 0.6 N·m (4.4 lbf·in to 5.3 lbf·in)

Note:

1. A ground wire is not necessary. Do not use the ground wire.
2. Only two screws are necessary to install the option on a GA700, GA800, and CR700 drive.

6. Firmly connect the Ethernet communication cables to CN1B (Port 2) (K), and/or CN1A (Port 1) (L).

Isolate communication cables from main circuit wiring and other electrical and power lines. Make sure that you firmly connect the cable end. Refer to [Communication Cable Specifications on page 22](#) for more information.

Note:

Maximum transmission distance is 100 m (328 ft). Minimum wiring distance between stations is 0.2 m (7.9 in).

7. Reattach the LED Status Ring board (M), front cover (D), and keypad (I).

Refer to the drive manuals for more information.

NOTICE Do not pinch cables between the front cover or the LED Status Ring board and the drive. Failure to comply could cause erroneous operation.

Note:

- Replace the keypad connector (E), then install the keypad.
- Put the keypad connector tab (F) into the holder when you install the keypad connector to the holder.

8. Set drive parameters in [Related Drive Parameters on page 24](#) for correct option performance.

■ Procedure D

This section shows the procedure to install and wire the option on HV600 and FP605 drives.

Prepare the Drive for the Option

Correctly wire the drive as specified by the manual packaged with the drive. Make sure that the drive functions correctly. Refer to the drive manuals for more information.

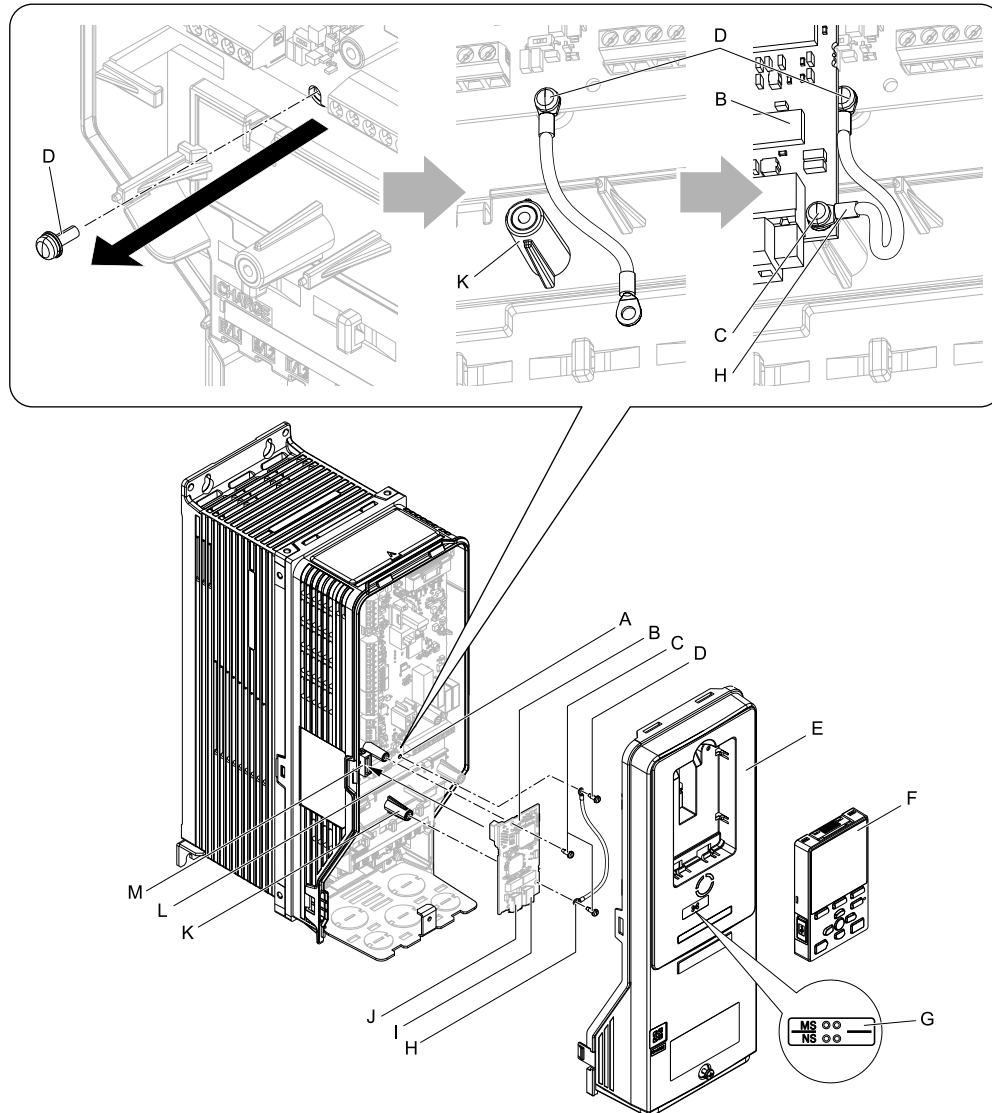

A - Drive grounding terminal (FE)

B - Option

C - Included screws

D - Ground screw

E - Drive front cover

F - Keypad

G - LED label

H - Ground wire

I - Option modular connector CN1B (Port 2) (RJ45)

J - Option modular connector CN1A (Port 1) (RJ45)

K - Stud

L - Insertion point for CN5 connector (HV600: CN5, FP605: CN5-A)

M - Connector CN5 (HV600: CN5, FP605: CN5-A)

Figure 5.7 Drive Components with Option

Install the Option

⚠ DANGER *Electrical Shock Hazard. Do not examine, connect, or disconnect wiring on an energized drive. Before servicing, disconnect all power to the equipment and wait for the time specified on the warning label at a minimum. The internal capacitor stays charged after the drive is de-energized. The charge indicator LED extinguishes when the DC bus voltage decreases below 50 Vdc. When all indicators are OFF, measure for dangerous voltages to make sure that the drive is safe. If you do work on the drive when it is energized, it will cause serious injury or death from electrical shock.*

NOTICE *Damage to Equipment. When you touch the option, make sure that you observe correct electrostatic discharge (ESD) procedures. If you do not follow procedures, it can cause ESD damage to the drive circuitry.*

1. Shut off power to the drive and wait for the time specified on the drive warning label at a minimum. Make sure that the charge indicator LED is unlit, then remove the keypad and front cover. Refer to the drive manuals for more information.
2. Remove the keypad (F) and front cover (E).
3. Put the LED label (G) in the correct position on the drive front cover (E).

4. Remove the screw (D) installed in the drive grounding terminal (A).
5. Use the screw (C) installed in the FE ground terminal of the drive (A) to connect one end of the included ground wire (H) to the ground terminal on the drive.
Route ground wire on the right side of the stud (K).
Tighten the screw to a correct tightening torque:
 - 0.5 N·m to 0.6 N·m (4.4 lbf·in to 5.3 lbf·in)
6. Install the option (B) into the CN5 connector (M) (HV600: CN5, FP605: CN5-A) on the drive and use one of the included screws (C) to put it in place.
Tighten the screw to a correct tightening torque:
 - 0.5 N·m to 0.6 N·m (4.4 lbf·in to 5.3 lbf·in)

Note:

Only two screws are necessary to install the option on HV600 and FP605 drives.

7. Use one of the remaining included screws (C) to connect the ground wire (H) to the ground terminal and installation hole on the option (B).
Refer to [Figure 5.7](#) for instruction about crimp terminal orientation and wire routing.
Tighten the screw to a correct tightening torque:
 - 0.5 N·m to 0.6 N·m (4.4 lbf·in to 5.3 lbf·in)
8. Firmly connect the Ethernet communication cables to CN1B (Port 2) (I), and/or CN1A (Port 1) (J).
Isolate communication cables from main circuit wiring and other electrical and power lines. Make sure that you firmly connect the cable end. Refer to [Communication Cable Specifications on page 22](#) for more information.
9. Reattach the drive front cover (E) and the keypad (F).
Refer to the drive manuals for more information.

NOTICE

Do not pinch cables between the front covers and the drive. Failure to comply could cause erroneous operation.
10. Set drive parameters in [Related Drive Parameters on page 24](#) for correct option performance.

◆ IGMP Snooping

Switches implementing IGMP Snooping are strongly recommended. When IGMP Snooping is used, devices will only receive the multicast packets in which they are interested.

◆ Communication Cable Specifications

Yaskawa recommends using shielded Cat5e cable. The Yaskawa warranty does not cover other cable types.

■ Option Connection Diagram

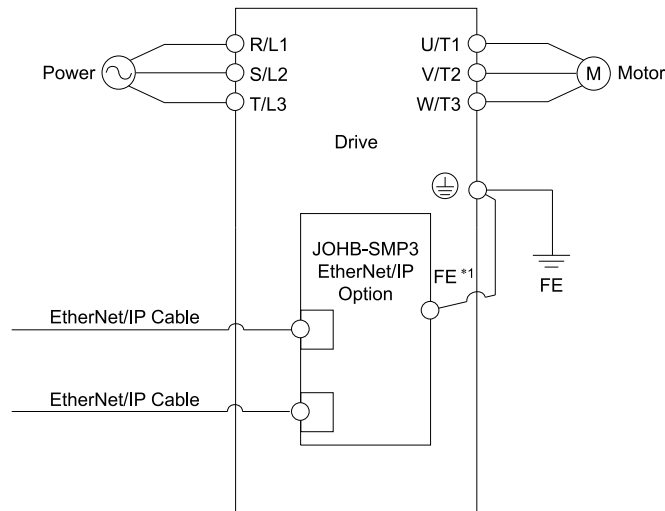

Figure 5.8 Option Connection Diagram

*1 Connect the specified ground wire for installations on 1000-series, GA500, HV600 and FP605 drives. The ground wire is not necessary for installation on GA700, GA800, or CR700 drives.

■ Communication Topology Specifications

Drives equipped with the JOHB-SMP3 option can be connected to network in either star or line topology.

- **Star Topology**
Use either one of the communication connectors CN1A (Port 1) or CN1B (Port 2).
- **Daisy-Chained Topology**
Use the communication connectors CN1A (Port 1) and CN1B (Port 2) at the same time. A switch is not necessary for this connection.

Note:

- This option does not support STP and RSTP.
- To use this option in a ring topology, prepare a separate device that supports STP and RSTP in the same network.
- If the link speed of Port 1 is different than the link speed of Port 2, it will trigger a *PA1 [PLC Alarm 1]* and the drive will not send data between the ports. To prevent this alarm, set *F7-14 = 1 [Duplex Mode Selection = Auto/Auto (Auto Negotiation/Auto Negotiation)]* and set the two connected nodes to the same link speed, set the two connected nodes to the same speed, and make sure that *F7-15 ≠ 101 or 102 [Communication Speed Selection ≠ 10/100 Mbps (10 Mbps/100 Mbps) or 100/10 Mbps (100 Mbps/10 Mbps)]*.

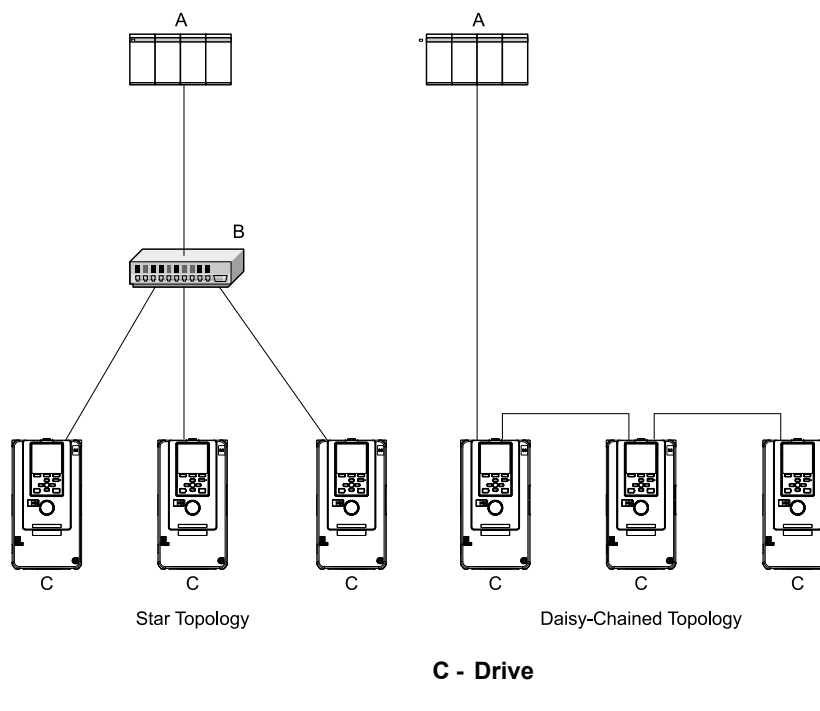

Figure 5.9 Communication Cable Wiring

◆ EDS Files

For easy network implementation of drives equipped with the option, please obtain the EDS file from the web page on the option or from the Yaskawa website: Contact Yaskawa or your nearest sales representative for more information.

- [EtherNet/IP Page on page 106](#)
- Yaskawa website
 - Japan: <http://www.e-mechatronics.com>
 - North or South America regions: <http://www.yaskawa.com>
 - Europe: <http://www.yaskawa.eu.com>
 - Other areas: Check the back cover of these manuals.

Note:

Download the EDS file for JOHB-SMP3 option. The correct EDS file is necessary to make the JOHB-SMP3 operate correctly as a device on the network.

6 Related Drive Parameters

These parameters set the drive for operation with the option. Make sure that the parameter settings in this table are correct before you start network communications.

Note:

- Hex.: MEMOBUS addresses that you can use to change parameters over network communication are represented in hexadecimal numbers.
- Expert: The parameter that is available in Expert Mode only. When $A1-01 = 3$ [Access Level Selection = Expert Level], Expert Mode parameters can be displayed on and set with the keypad.

No. (Hex.)	Name	Description	Default (Range)
b1-01 (0180)	Frequency Reference Selection 1	<p>Selects the input method for frequency reference.</p> <p>0 : Keypad 1 : Analog Input 2 : Memobus/Modbus Communications 3 : Option PCB 4 : Pulse Train Input</p> <p>Note:</p> <ul style="list-style-type: none"> • Set $b1-01 = 3$ to use the client to control the frequency reference of the drive. • The default setting is different for different drives. Refer to the instruction manual of your specific drive for more information. 	1 (0 - 4)
b1-02 (0181)	Run Command Selection 1	<p>Sets the input method for the Run command.</p> <p>0 : Keypad 1 : Digital Input 2 : Memobus/Modbus Communications 3 : Option PCB 7 : AUTO Command + Term Run 8 : AUTO Command + Serial Run 9 : AUTO Command + Option Run</p> <p>Note:</p> <ul style="list-style-type: none"> • Set $b1-02 = 3$ or 9 to start and stop the drive with the client using serial communications. • The setting range is different for different drives. Refer to the instruction manual of your specific drive for more information. 	1 (0 - 9)
F6-01 (03A2)	Communication Error Selection	<p>Selects drive response when the drive detects a <i>bUS</i> [Option Communication Error] error during communications with the option.</p> <p>0 : Ramp to Stop 1 : Coast to Stop 2 : Fast Stop (Use C1-09) 3 : Alarm Only 4 : Alarm (Run at $d1-04$) 5 : Alarm - Ramp Stop</p> <p>Note:</p> <ul style="list-style-type: none"> • When you set this parameter to 3 or 4, the drive will continue operation after it detects a fault. Separately prepare safety protection equipment and systems, for example fast-stop switches. • Refer to the drive manual to know if settings 4 and 5 are available. • The setting range for 1000-Series drives is different for different software versions. Refer to the Peripheral Devices & Options section of the drive instruction manual for more information. • Changes to this parameter take effect immediately. It is not necessary to cycle power on the drive. 	1 (0 - 5)

No. (Hex.)	Name	Description	Default (Range)
F6-02 (03A3)	Comm External Fault (EF0) Detect	Selects the conditions at which EF0 [Option Card External Fault] is detected. 0 : Always Detected 1 : Detected during RUN Only	0 (0, 1)
F6-03 (03A4)	Comm External Fault (EF0) Select	Selects the operation of the drive when EF0 [Option Card External Fault] is detected. 0 : Ramp to Stop 1 : Coast to Stop 2 : Fast Stop (Use C1-09) 3 : Alarm Only Note: When you set this parameter to 3, the drive will continue operation after it detects a fault. Separately prepare safety protection equipment and systems, for example fast stop switches.	1 (0 - 3)
F6-06 (03A7)	Torque Reference/Limit by Comm	Selects whether to enable or disable the torque reference and torque limit received from the communication option. 0 : Disabled 1 : Enabled Note: • Control method availability of this parameter is different for different product series. –1000-Series Parameter is available when A1-02 = 3, 6, 7 [Control Method Selection = Closed Loop Vector, PM Advanced Open Loop Vector, PM Closed Loop Vector]. When you enable this parameter, d5-01 [Torque Control Selection] sets the drive to read the value as the Torque Limit value or the Torque Reference value. d5-01 = 0 [Speed Control]: Torque Limit d5-01 = 1 [Torque Control]: Torque Reference When A1-02 = 6 [Control Method Selection = PM Advanced Open Loop Vector], the drive reads this value as the Torque Limit. –GA500 Parameter is available when A1-02 = 2, 6, 8 [Control Method Selection = Open Loop Vector PM Advanced Open Loop Vector, EZ Vector Control]. The drive reads this value as the Torque Limit. –GA700, GA800 Parameter is available when A1-02 = 2, 3, 4, 6, 7, 8 [Control Method Selection = Open Loop Vector, Closed Loop Vector, Advanced Open Loop Vector, PM Advanced Open Loop Vector, PM Closed Loop Vector, EZ Vector Control]. When you enable this parameter, d5-01 [Torque Control Selection] sets the drive to read the value as the Torque Limit value or the Torque Reference value. d5-01 = 0 [Speed Control]: Torque Limit d5-01 = 1 [Torque Control]: Torque Reference When A1-02 = 2, 8 [Control Method Selection = Open Loop Vector, EZ Vector Control], the drive reads this value as the Torque Limit. –CR700 Parameter is available when A1-02 = 2, 3, 4 [Control Method Selection = Open Loop Vector, Closed Loop Vector, Advanced Open Loop Vector]. –HV600, FP605 Torque Limit is enabled when A1-02 = 8 [Control Method Selection = EZ Vector Control]. • If the PLC does not supply a torque reference or torque limit when F6-06 = 1 [Torque Reference/Limit by Comm = Enabled], the motor cannot rotate.	0 (0, 1)
F6-07 (03A8)	Multi-Step Ref @ NetRef/ComRef	0 : Disable Multi-Step References 1 : Enable Multi-Step References Note: Default setting of F6-07 is 1 for GA500.	0 (0, 1)
F6-08 (036A)	Comm Parameter Reset @Initialize	Selects whether communication-related parameters F6-xx and F7-xx are set back to original default values when you use parameter A1-03 [Initialize Parameters] to initialize the drive. 0 : No Reset - Parameters Retained 1 : Reset - Back to Factory Default Note: When you set F6-08 to 1 and you then use A1-03 to initialize the drive, the drive will not change this setting value.	0 (0, 1)
F6-14 (03BB)	Bus Error Auto Reset	Enables and disables the automatic reset of a bUS [Option Communication Error] fault. 0 : Disabled 1 : Enabled Note: • This parameter is not available in all 1000-series drives. • Changes to this parameter take effect immediately. It is not necessary to cycle power on the drive.	0 (0, 1)
F6-15 (0B5B)	Comm. Option Parameters Reload	Sets when the drive will activate the F6-xx/F7-xx communications-related parameters that you changed. Use this parameter as an alternative to cycling power to the drive to active parameters. 0 : Reload at Next Power Cycle 1 : Reload Now 2 : Cancel Reload Request Note: • F6-15 is reset to 0 after setting 1 or 2. • This parameter is not available in all 1000-series drives. • Changes to this parameter take effect immediately. It is not necessary to cycle power on the drive.	0 (0 - 2)
F6-54 (03C5)	Idle Fault Detection	Sets the drive operation when communication is in Idle Mode. 0 : Stop 1 : Ignore	0 (0 - 4)

6 Related Drive Parameters

No. (Hex.)	Name	Description	Default (Range)
		2 : Vendor Specific 3 : RUN Forward 4 : RUN Reverse Note: <ul style="list-style-type: none"> Change the parameter then cycle power on the drive. When you set $F6-54 = 2$, use $F6-01$ to select drive operation to stop or continue. 	
F7-01 (03E5)	IP Address 1	Sets the static/fixed IP address. Sets the most significant octet. Note: <ul style="list-style-type: none"> This parameter is only effective when $F7-13 = 0$ [Address Mode at Startup = Static]. All IP Addresses must be unique. You must cycle power to the drive for the changes to take effect. For non-1000 series drives, you can set $F6-15 = 1$ [Comm. Option Parameters Reload = Reload Now]. 	192 (0 - 255)
F7-02 (03E6)	IP Address 2	Sets the static/fixed IP address. Sets the second most significant octet. Note: <ul style="list-style-type: none"> This parameter is only effective when $F7-13 = 0$ [Address Mode at Startup = Static]. All IP Addresses must be unique. You must cycle power to the drive for the changes to take effect. For non-1000 series drives, you can set $F6-15 = 1$ [Comm. Option Parameters Reload = Reload Now]. 	168 (0 - 255)
F7-03 (03E7)	IP Address 3	Sets the static/fixed IP address. Sets the third most significant octet. Note: <ul style="list-style-type: none"> This parameter is only effective when $F7-13 = 0$ [Address Mode at Startup = Static]. All IP Addresses must be unique. You must cycle power to the drive for the changes to take effect. For non-1000 series drives, you can set $F6-15 = 1$ [Comm. Option Parameters Reload = Reload Now]. 	1 (0 - 255)
F7-04 (03E8)	IP Address 4	Sets the static/fixed IP address. Sets the fourth most significant octet. Note: <ul style="list-style-type: none"> This parameter is only effective when $F7-13 = 0$ [Address Mode at Startup = Static]. All IP Addresses must be unique. You must cycle power to the drive for the changes to take effect. For non-1000 series drives, you can set $F6-15 = 1$ [Comm. Option Parameters Reload = Reload Now]. 	20 (0 - 255)
F7-05 (03E9)	Subnet Mask 1	Sets the static/fixed Subnet Mask. Sets the most significant octet. Note: <ul style="list-style-type: none"> This parameter is only effective when $F7-13 = 0$ [Address Mode at Startup = Static]. All IP Addresses must be unique. You must cycle power to the drive for the changes to take effect. For non-1000 series drives, you can set $F6-15 = 1$ [Comm. Option Parameters Reload = Reload Now]. 	255 (0 - 255)
F7-06 (03EA)	Subnet Mask 2	Sets the static/fixed Subnet Mask. Sets the second most significant octet. Note: <ul style="list-style-type: none"> This parameter is only effective when $F7-13 = 0$ [Address Mode at Startup = Static]. All IP Addresses must be unique. You must cycle power to the drive for the changes to take effect. For non-1000 series drives, you can set $F6-15 = 1$ [Comm. Option Parameters Reload = Reload Now]. 	255 (0 - 255)
F7-07 (03EB)	Subnet Mask 3	Sets the static/fixed Subnet Mask. Sets the third most significant octet. Note: <ul style="list-style-type: none"> This parameter is only effective when $F7-13 = 0$ [Address Mode at Startup = Static]. All IP Addresses must be unique. You must cycle power to the drive for the changes to take effect. For non-1000 series drives, you can set $F6-15 = 1$ [Comm. Option Parameters Reload = Reload Now]. 	255 (0 - 255)
F7-08 (03EC)	Subnet Mask 4	Sets the static/fixed Subnet Mask. Parameter F7-08 sets the fourth most significant octet. Note: <ul style="list-style-type: none"> This parameter is only effective when $F7-13 = 0$ [Address Mode at Startup = Static]. All IP Addresses must be unique. You must cycle power to the drive for the changes to take effect. For non-1000 series drives, you can set $F6-15 = 1$ [Comm. Option Parameters Reload = Reload Now]. 	0 (0 - 255)
F7-09 (03ED)	Gateway Address 1	Sets the static/fixed Gateway address. Sets the most significant octet. Note: <ul style="list-style-type: none"> This parameter is only effective when $F7-13 = 0$ [Address Mode at Startup = Static]. All IP Addresses must be unique. You must cycle power to the drive for the changes to take effect. For non-1000 series drives, you can set $F6-15 = 1$ [Comm. Option Parameters Reload = Reload Now]. 	192 (0 - 255)
F7-10 (03EE)	Gateway Address 2	Sets the static/fixed Gateway address. Sets the second most significant octet. Note: <ul style="list-style-type: none"> This parameter is only effective when $F7-13 = 0$ [Address Mode at Startup = Static]. All IP Addresses must be unique. You must cycle power to the drive for the changes to take effect. For non-1000 series drives, you can set $F6-15 = 1$ [Comm. Option Parameters Reload = Reload Now]. 	168 (0 - 255)
F7-11 (03EF)	Gateway Address 3	Sets the static/fixed Gateway address. Sets the third most significant octet. Note: <ul style="list-style-type: none"> This parameter is only effective when $F7-13 = 0$ [Address Mode at Startup = Static]. All IP Addresses must be unique. You must cycle power to the drive for the changes to take effect. For non-1000 series drives, you can set $F6-15 = 1$ [Comm. Option Parameters Reload = Reload Now]. 	1 (0 - 255)

No. (Hex.)	Name	Description	Default (Range)
F7-12 (03F0)	Gateway Address 4	Sets the static/fixed Gateway address. Parameter F7-12 sets the fourth most significant octet. Note: • This parameter is only effective when $F7-13 = 0$ [Address Mode at Startup = Static]. • All IP Addresses must be unique. • You must cycle power to the drive for the changes to take effect. For non-1000 series drives, you can set $F6-15 = 1$ [Comm. Option Parameters Reload = Reload Now].	1 (0 - 255)
F7-13 (03F1)	Address Startup Mode	Selects how the option address is set. 0 : Static (Use F7-01 to F7-12 to set.) 1 : BOOTP (Use network address.) 2 : DHCP (Use network address.) Note: You must cycle power to the drive for the changes to take effect. For non-1000 series drives, you can set $F6-15 = 1$ [Comm. Option Parameters Reload = Reload Now].	2 (0 - 2)
F7-14 (03F2)	Duplex Mode Selection	Sets duplex mode settings (Port 1 (CN1A)/Port 2 (CN1B)). 0 : Half/Half (Half Duplex/Half Duplex) 1 : Auto/Auto (Auto Negotiation/Auto Negotiation) 2 : Full/Full (Full Duplex/Full Duplex) 3 : Half/Auto (Half Duplex/Auto Negotiation) 4 : Half/Full (Half Duplex/Full Duplex) 5 : Auto/Half (Auto Negotiation/Half Duplex) 6 : Auto/Full (Auto Negotiation/Full Duplex) 7 : Full/Half (Full Duplex/Half Duplex) 8 : Full/Auto (Full Duplex/Auto Negotiation) Note: You must cycle power to the drive for the changes to take effect. For non-1000 series drives, you can set $F6-15 = 1$ [Comm. Option Parameters Reload = Reload Now].	1 (0 - 8)
F7-15 (03F3)	Communication Speed Selection	Sets the communications speed (Port 1 (CN1A)/Port 2 (CN1B)). 10 : 10/10 Mbps (10 Mbps/10 Mbps) 100 : 100/100 Mbps (100 Mbps/100 Mbps) 101 : [Not Used/No function] 10/100 Mbps (10 Mbps/100 Mbps) 102 : [Not Used/No function] 100/10 Mbps (100 Mbps/10 Mbps) Note: • $F7-15$ is only effective when the port is set to half or full duplex in $F7-14$ [Duplex Mode Selection]. • You must cycle power to the drive for the changes to take effect. For non-1000 series drives, you can set $F6-15 = 1$ [Comm. Option Parameters Reload = Reload Now].	10 (10 - 102)
F7-16 (03F4)	Timeout Value	Sets the detection time for a communications timeout. Note: • Set this parameter to 0.0 to disable the connection timeout function. • This parameter is not available in all 1000-series drives. • Changes to this parameter take effect immediately. It is not necessary to cycle power on the drive.	0.0 s (0.0 s - 30.0 s)
F7-17 (03F5)	EtherNet/IP Speed Scaling Factor	Sets the scaling factor for the speed monitor in EtherNet/IP Class ID 2A (Hex.) Object. Note: Changes to this parameter take effect immediately. It is not necessary to cycle power on the drive.	0 (-15 - 15)
F7-18 (03F6)	EtherNet/IP Current Scale Factor	Sets the scaling factor for the output current monitor in EtherNet/IP Class ID 2A (Hex.) Object. Note: Changes to this parameter take effect immediately. It is not necessary to cycle power on the drive.	0 (-15 - 15)
F7-19 (03F7)	EtherNet/IP Torque Scale Factor	Sets the scaling factor for the torque monitor in EtherNet/IP Class ID 2A (Hex.) Object. Note: Changes to this parameter take effect immediately. It is not necessary to cycle power on the drive.	0 (-15 - 15)
F7-20 (03F8)	EtherNet/IP Power Scaling Factor	Sets the scaling factor for the power monitor in EtherNet/IP Class ID 2A (Hex.) Object. Note: Changes to this parameter take effect immediately. It is not necessary to cycle power on the drive.	0 (-15 - 15)
F7-21 (03F9)	EtherNet/IP Voltage Scale Factor	Sets the scaling factor for the voltage monitor in EtherNet/IP Class ID 2A (Hex.) Object. Note: Changes to this parameter take effect immediately. It is not necessary to cycle power on the drive.	0 (-15 - 15)
F7-22 (03FA)	EtherNet/IP Time Scaling	Sets the scaling factor for the time monitor in EtherNet/IP Class ID 2A (Hex.) Object. Note: Changes to this parameter take effect immediately. It is not necessary to cycle power on the drive.	0 (-15 - 15)

6 Related Drive Parameters

No. (Hex.)	Name	Description	Default (Range)
F7-23 - F7-27 (03FB - 03FF) F7-28 - F7-32 (0370 - 0374)	Dynamic Output Assembly Parameters 1 to 10	Parameters used in Output Assemblies 116, 117, 118, 119, 120. Each parameter contains a MEMOBUS/Modbus address. The value received for the Output Assembly will be written to this corresponding MEMOBUS/Modbus address. A MEMOBUS/Modbus address value of 0 means that the value received for the Output Assembly will not be written to any MEMOBUS/Modbus register.	0 (-)
F7-33 - F7-42 (0375 to 037E)	Dynamic Input Assembly Parameters 1 to 10	Parameters used in Input Assemblies 166, 167, 168, 169, 170. Each parameter contains a MEMOBUS/Modbus address. The value sent for the Input Assembly will be read from this corresponding MEMOBUS/Modbus address. A MEMOBUS/Modbus address value of 0 means that the value sent for the Input Assembly is not defined by the user, therefore the option default register value will be returned.	0 (-)

Table 6.1 Option Monitor

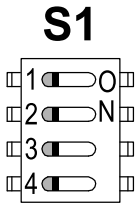
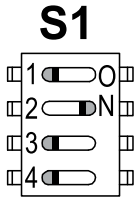
No.	Name	Description	Range
U4-75	Communication OPT Protocol	<p>Shows the setting of the DIP switch S1.</p> <ul style="list-style-type: none"> 70 = All switches OFF (incorrect for EtherNet/IP)  <ul style="list-style-type: none"> 71 = Incorrect for EtherNet/IP 72 = Switch 2 ON, all others OFF (correct for EtherNet/IP)  <ul style="list-style-type: none"> 73 to 7F = Other switch positions that are incorrect for EtherNet/IP <p>Note: Setting value is shown only when you use the drive with the latest software version. Contact Yaskawa or your nearest sales representative for more information.</p>	00 - FF (Hex.)
U4-76 - U4-78	MAC Address 1	<p>Shows the main MAC Address.</p> <ul style="list-style-type: none"> U4-76: First octet, Second octet U4-77: Third octet, Fourth octet U4-78: Fifth octet, Sixth octet <p>Note: Contact Yaskawa or your nearest sales representative for more information about corresponding drives and the drive software versions.</p>	0000 - FFFF (Hex.)
U4-79 - U4-81 Expert	MAC Address 2	<p>Shows the second MAC Address.</p> <ul style="list-style-type: none"> U4-79: First octet, Second octet U4-80: Third octet, Fourth octet U4-81: Fifth octet, Sixth octet <p>Note: Contact Yaskawa or your nearest sales representative for more information about corresponding drives and the drive software versions.</p>	0000 - FFFF (Hex.)
U4-82 - U4-84 Expert	MAC Address 3	<p>Shows the third MAC Address.</p> <ul style="list-style-type: none"> U4-82: First octet, Second octet U4-83: Third octet, Fourth octet U4-84: Fifth octet, Sixth octet <p>Note: Contact Yaskawa or your nearest sales representative for more information about corresponding drives and the drive software versions.</p>	0000 - FFFF (Hex.)
U6-80 - U6-83	Option IP Address 1 - 4	<p>Shows the currently available local IP Address.</p> <ul style="list-style-type: none"> U6-80: First octet U6-81: Second octet U6-82: Third octet U6-83: Fourth octet 	0 - 255
U6-84 - U6-87	Online Subnet 1 - 4	<p>Shows the currently available subnet mask.</p> <ul style="list-style-type: none"> U6-84: First octet U6-85: Second octet U6-86: Third octet 	0 - 255

No.	Name	Description	Range
		<ul style="list-style-type: none"> • U6-87: Fourth octet 	
U6-88 - U6-91	Online Gateway 1 - 4	Shows the currently available gateway address. <ul style="list-style-type: none"> • U6-88: First octet • U6-89: Second octet • U6-90: Third octet • U6-91: Fourth octet 	0 - 255
U6-92	Online Speed	Shows CN1A Port 1 link speed currently available.	10: 10 Mbps 100: 100 Mbps
U6-93	Online Duplex	Shows CN1A Port 1 duplex setting currently available.	0: Half/Half 1: Full/Full
U6-94	OPT SPARE 1	Shows CN1B Port 2 link speed currently available.	10: 10 Mbps 100: 100 Mbps
U6-95	OPT SPARE 2	Shows CN1B Port 2 duplex setting currently available.	0: Half/Half 1: Full/Full
U6-97	OPT SPARE 4	Shows option software version.	-
U6-98	First Fault	Shows first option fault.	-
U6-99	Current Fault	Shows current option fault.	-

7 EtherNet/IP Configuring Messaging

This section provides information on methods used to control the drive and converter with the option installed.

◆ Drive Polled Configuration

The assemblies in [Table 7.1](#) are available for polled I/O:

Note:

These assemblies are not available in D1000 and R1000.

Table 7.1 Supported Polled I/O Assemblies

Assembly Number (Hex.)	Description	Type	Bytes	Page
20 (14)	EtherNet/IP Basic Speed Control Output	Output	4	31
21 (15)	EtherNet/IP Extended Speed Control Output	Output	4	32
22 (16)	EtherNet/IP Speed and Torque Control Output	Output	6	32
23 (17)	EtherNet/IP Extended Speed and Torque Control Output	Output	6	33
70 (46)	EtherNet/IP Basic Speed Control Input	Input	4	45
71 (47)	EtherNet/IP Extended Speed Control Input	Input	4	45
72 (48)	EtherNet/IP Speed and Torque Control Input	Input	6	46
73 (49)	EtherNet/IP Extended Speed and Torque Control Input	Input	6	47
100 (64)	(Vendor Specific Yaskawa Electric (YE) Assy) MEMOBUS Message Output	Output	5	33
101 (65)	(Vendor Specific Yaskawa Electric (YE) Assy) Speed/Torque Control Output	Output	8	34
115 (73)	(Vendor Specific Yaskawa Electric (YE) Assy) Extended Speed/Torque Control Output	Output	40	35
116 (74)	(Vendor Specific Yaskawa Electric (YE) Assy) High Speed/Torque Control Output	Output	44	37
117 (75)	(Vendor Specific Yaskawa Electric (YE) Assy) 8-Byte Dynamic Output	Output	8	39
118 (76)	(Vendor Specific Yaskawa Electric (YE) Assy) 12-Byte Dynamic Output	Output	12	40
119 (77)	(Vendor Specific Yaskawa Electric (YE) Assy) 18-Byte Dynamic Output	Output	18	41
120 (78)	(Vendor Specific Yaskawa Electric (YE) Assy) 24-Byte Dynamic Output	Output	24	42
130 (82)	(Vendor Specific Yaskawa Electric (YE) Assy) Gateway Consume Assembly	Output	48	44
150 (96)	(Vendor Specific Yaskawa Electric (YE) Assy) MEMOBUS Message Input	Input	5	47
151 (97)	(Vendor Specific Yaskawa Electric (YE) Assy) Speed/Torque Status Input	Input	8	48
155 (9B)	(Vendor Specific Yaskawa Electric (YE) Assy) Extended Speed/Torque Status Input	Input	40	50
166 (A6)	(Vendor Specific Yaskawa Electric (YE) Assy) High Speed/Torque Status Input	Input	44	52
167 (A7)	(Vendor Specific Yaskawa Electric (YE) Assy) 8-Byte Dynamic Input	Input	8	55
168 (A8)	(Vendor Specific Yaskawa Electric (YE) Assy) 12-Byte Dynamic Input	Input	12	56
169 (A9)	(Vendor Specific Yaskawa Electric (YE) Assy) 18-Byte Dynamic Input	Input	18	58
170 (AA)	(Vendor Specific Yaskawa Electric (YE) Assy) 24-Byte Dynamic Input	Input	24	59
180 (B4)	(Vendor Specific Yaskawa Electric (YE) Assy) Gateway Produce Assembly	Input	48	60

◆ Converter Polled Configuration

The assemblies in [Table 7.2](#) are available for polled I/O:

Note:

These assemblies apply to D1000/R1000 converters.

Table 7.2 Supported Polled I/O Assemblies

Assembly Number (Hex.)	Description	Type	Bytes	Page
20 (14)	EtherNet/IP Basic Speed Control Output	Output	4	62
21 (15)	EtherNet/IP Extended Speed Control Output	Output	4	62

Assembly Number (Hex.)	Description	Type	Bytes	Page
22 (16)	EtherNet/IP Speed and Torque Control Output	Output	6	63
23 (17)	EtherNet/IP Extended Speed and Torque Control Output	Output	6	63
70 (46)	EtherNet/IP Basic Speed Control Input	Input	4	74
71 (47)	EtherNet/IP Extended Speed Control Input	Input	4	74
72 (48)	EtherNet/IP Speed and Torque Control Input	Input	6	75
73 (49)	EtherNet/IP Extended Speed and Torque Control Input	Input	6	75
101 (65)	(Vendor Specific Yaskawa Electric (YE) Assy) Speed/Torque Control Output	Output	8	64
115 (73)	(Vendor Specific Yaskawa Electric (YE) Assy) Extended Speed/Torque Control Output	Output	40	65
116 (74)	(Vendor Specific Yaskawa Electric (YE) Assy) High Speed/Torque Control Output	Output	44	67
117 (75)	(Vendor Specific Yaskawa Electric (YE) Assy) 8-Byte Dynamic Output 2	Output	8	69
118 (76)	(Vendor Specific Yaskawa Electric (YE) Assy) 12-Byte Dynamic Output 4	Output	12	70
119 (77)	(Vendor Specific Yaskawa Electric (YE) Assy) 18-Byte Dynamic Output 7	Output	18	71
120 (78)	(Vendor Specific Yaskawa Electric (YE) Assy) 24-Byte Dynamic Output 10	Output	24	73
151 (97)	(Vendor Specific Yaskawa Electric (YE) Assy) Speed/Torque Status Input	Input	8	76
155 (9B)	(Vendor Specific Yaskawa Electric (YE) Assy) Extended Speed/Torque Status Input	Input	40	77
166 (A6)	(Vendor Specific Yaskawa Electric (YE) Assy) High Speed/Torque Status Input	Input	44	79
167 (A7)	(Vendor Specific Yaskawa Electric (YE) Assy) 8-Byte Dynamic Input 2	Input	8	82
168 (A8)	(Vendor Specific Yaskawa Electric (YE) Assy) 12-Byte Dynamic Input 4	Input	12	84
169 (A9)	(Vendor Specific Yaskawa Electric (YE) Assy) 18-Byte Dynamic Input 7	Input	18	85
170 (AA)	(Vendor Specific Yaskawa Electric (YE) Assy) 24-Byte Dynamic Input 10	Input	24	86

8 Output Assemblies (Drive Consumes)

Note:

The convention in this manual is from the PLC perspective. As such, an assembly is called an “Output Assembly” when outputted from the PLC and received by this node. This section details “Output Assemblies” that are “Consumed” by the drive.

◆ EtherNet/IP Basic Speed Control Output - 20 (0x14)

Output Instance	Word	Byte	Bit 7	Bit 6	Bit 5	Bit 4	Bit 3	Bit 2	Bit 1	Bit 0	
20	0	0	-	-	-	-	-	Fault Reset	-	Run Fwd	
		1	-								
	1	2	Speed Reference (Low Byte)								
		3	Speed Reference (High Byte)								

Name	Description
Run Fwd	Forward Run Command 0: Stop 1: Forward Run
Fault Reset	Fault Reset 0: - 1: Fault Reset
Speed Reference	Speed Command Sets drive speed reference. Speed reference data: Frequency reference/2 ^{SS} (SS: Speed scale) Setting range: 0 - FFFF (Hex.) For example, when setting a reference of 4096 with a speed scale of 2: Speed reference data = 4096/2 ² = 1024 = 400 (Hex.) Unit depends on o1-03.

◆ EtherNet/IP Extended Speed Control Output - 21 (0x15)

Output Instance	Word	Byte	Bit 7	Bit 6	Bit 5	Bit 4	Bit 3	Bit 2	Bit 1	Bit 0	
21	0	0	-	NetRef	NetCtrl	-	-	Fault Reset	Run Rev	Run Fwd	
		1	-								
	1	2	Speed Reference (Low Byte)								
		3	Speed Reference (High Byte)								

Name	Description
Run Fwd	Forward Run Command 0: Stop 1: Forward Run
Run Rev	Reverse Run Command 0: Stop 1: Reverse Run
Fault Reset	Fault Reset 0: - 1: Fault Reset
NetCtrl	Run command from network 0: Depends on b1-02 1: Enables the Run command from network
NetRef	Speed reference from network 0: Depends on b1-01 1: Enables the speed reference from network
Speed Reference	Speed Command Sets drive speed reference. Speed reference data: Frequency reference/2 ^{SS} (SS: Speed scale) Setting range: 0 - FFFF (Hex.) For example, when setting a reference of 4096 with a speed scale of 2: Speed reference data = 4096/2 ² = 1024 = 400 (Hex.) Unit depends on o1-03.

◆ EtherNet/IP Speed and Torque Control Output - 22 (0x16)

Output Instance	Word	Byte	Bit 7	Bit 6	Bit 5	Bit 4	Bit 3	Bit 2	Bit 1	Bit 0	
22	0	0	-	-	-	-	-	Fault Reset	-	Run Fwd	
		1	-								
	1	2	Speed Reference (Low Byte)								
		3	Speed Reference (High Byte)								
	2	4	Torque Reference/Torque Limit (Low Byte)								
		5	Torque Reference/Torque Limit (High Byte)								

Name	Description
Run Fwd	Forward Run Command 0: Stop 1: Forward Run
Fault Reset	Fault Reset 0: - 1: Fault Reset

Name	Description
Speed Reference	Speed Command Sets drive speed reference. Speed reference data: Frequency reference/2 ^{SS} (SS: Speed scale) Setting range: 0 - FFFF (Hex.) For example, when setting a reference of 4096 with a speed scale of 2: Speed reference data = 4096/2 ² = 1024 = 400 (Hex.) Unit depends on o1-03.
Torque Reference/Torque Limit	Torque Reference/Torque Limit Sets the Torque Reference/Torque Limit. Sets in units of 0.1%. Sets the Torque Reference when using Torque Control [d5-01 = 1]. Sets the Torque Limit when using Speed Control [d5-01 = 0]. The Torque Reference/Torque Limit are disabled when F6-06 = 0.

◆ EtherNet/IP Extended Speed and Torque Control Output - 23 (0x17)

Output Instance	Word	Byte	Bit 7	Bit 6	Bit 5	Bit 4	Bit 3	Bit 2	Bit 1	Bit 0	
23	0	0	-	NetRef	NetCtrl	-	-	Fault Reset	Run Rev	Run Fwd	
		1	-								
	1	2	Speed Reference (Low Byte)								
		3	Speed Reference (High Byte)								
	2	4	Torque Reference/Torque Limit (Low Byte)								
		5	Torque Reference/Torque Limit (High Byte)								

Name	Description
Run Fwd	Forward Run Command 0: Stop 1: Forward Run
Run Rev	Reverse Run Command 0: Stop 1: Reverse Run
Fault Reset	Fault Reset 0: - 1: Fault Reset
NetCtrl	Run command is from network 0: Depends on b1-02 1: Run command is from network
NetRef	Speed reference is from network 0: Depends on b1-01 1: Speed reference is from network
Speed Reference	Sets drive speed reference. Speed reference data: Frequency reference x 2 ^{SS} (SS: Speed scale) Setting range: 0 - FFFF (Hex.) For example, when setting a reference of 4096 with a speed scale of 2: Speed reference data = 4096/2 ² = 1024 = 400 (Hex.) Unit depends on o1-03.
Torque Reference/Torque Limit	Sets the Torque Reference/Torque Limit. Sets in units of 0.1%. Sets the Torque Reference when using Torque Control [d5-01 = 1]. Sets the Torque Limit when using Speed Control [d5-01 = 0]. The Torque Reference/Torque Limit are disabled when F6-06 = 0.

◆ MEMOBUS/Modbus Message Output (Vendor Specific Yaskawa Electric (YE) Assy) - 100 (0x64)

Output Instance	Word	Byte	Bit 7	Bit 6	Bit 5	Bit 4	Bit 3	Bit 2	Bit 1	Bit 0
100	0	0	Function Code							
		1	Register Number (High Byte)							
	1	2	Register Number (Low Byte)							
		3	Register Data (High Byte)							
	2	4	Register Data (Low Byte)							

8 Output Assemblies (Drive Consumes)

Note:

This is a paired assembly (100/150).

Name	Description
Function Code	MEMOBUS/Modbus Function Code
Register Number	MEMOBUS/Modbus Register Number
Register Data	MEMOBUS/Modbus Register Data

Table 8.1 Function Code Decode Table

Function Code	MEMOBUS/Modbus Function
0x00	No Operation
0x03	Read Register
0x10	Write Register

Note:

Refer to the MEMOBUS/Modbus Data Table in Appendix C of the Technical Manual for a list of monitor data using the MEMOBUS/Modbus message area.

◆ (Vendor Specific Yaskawa Electric (YE) Assy) Speed/Torque Control Output - 101 (0x65)

Output Instance	Word	Byte	Bit 7	Bit 6	Bit 5	Bit 4	Bit 3	Bit 2	Bit 1	Bit 0	
101	0	0	Multi-Function Input 8	Multi-Function Input 7	Multi-Function Input 6	Multi-Function Input 5	Multi-Function Input 4	Multi-Function Input 3	Run Rev	Run Fwd	
		1	Multi-Function Digital Output 3	Multi-Function Digital Output 2	Multi-Function Digital Output 1	-	-	-	Fault Reset	External Fault	
	1	2	Speed Reference (Low Byte)								
		3	Speed Reference (High Byte)								
	2	4	Torque Reference/Torque Limit (Low Byte)								
		5	Torque Reference/Torque Limit (High Byte)								
	3	6	Torque Compensation (Low Byte)								
		7	Torque Compensation (High Byte)								

Name	Description
Run Fwd	Forward Run Command 0: Stop 1: Forward Run
Run Rev	Reverse Run Command 0: Stop 1: Reverse Run
Multi-Function Input 3	Terminal S3 Function Input 0: Terminal S3 Function [H1-03] OFF 1: Terminal S3 Function [H1-03] ON
Multi-Function Input 4	Terminal S4 Function Input 0: Terminal S4 Function [H1-04] OFF 1: Terminal S4 Function [H1-04] ON
Multi-Function Input 5	Terminal S5 Function Input 0: Terminal S5 Function [H1-05] OFF 1: Terminal S5 Function [H1-05] ON
Multi-Function Input 6	Terminal S6 Function Input 0: Terminal S6 Function [H1-06] OFF 1: Terminal S6 Function [H1-06] ON
Multi-Function Input 7	Terminal S7 Function Input 0: Terminal S7 Function [H1-07] OFF 1: Terminal S7 Function [H1-07] ON
Multi-Function Input 8	Terminal S8 Function Input 0: Terminal S8 Function [H1-08] OFF 1: Terminal S8 Function [H1-08] ON

Name	Description
External Fault	External Fault EF0 0: - 1: External Fault [EF0]
Fault Reset	Fault Reset 0: - 1: Fault Reset
Multi-Function Digital Output 1	Terminal M1/M2 (varies by drive model) 0: M1/M2 OFF 1: M1/M2 ON This function is enabled only when H2-01 is set to F. Note: The names of the digital outputs are different for different drive series.
Multi-Function Digital Output 2	Terminal M3/M4 (varies by drive model) 0: M3/M4 OFF 1: M3/M4 ON This function is enabled only when H2-02 is set to F. Note: The names of the digital outputs are different for different drive series.
Multi-Function Digital Output 3	Terminal M5/M6 (varies by drive model) 0: M5/M6 OFF 1: M5/M6 ON This function is enabled only when H2-03 is set to F. Note: The names of the digital outputs are different for different drive series.
Speed Reference	Speed Command Sets drive speed reference. Unit depends on o1-03. Unit is not affected by Speed Scale SS.
Torque Reference/Torque Limit	Torque Reference/Torque Limit Sets the Torque Reference/Torque Limit. Sets in units of 0.1%. Sets the Torque Reference when using Torque Control [d5-01 = 1]. Sets the Torque Limit when using Speed Control [d5-01 = 0]. The Torque Reference/Torque Limit are disabled when F6-06 = 0.
Torque Compensation	Torque Compensation Sets the amount of Torque Compensation Sets in units of 0.1%.

◆ (Vendor Specific Yaskawa Electric (YE) Assy) Extended Speed/Torque Control Output - 115 (0x73)

Output Instance	Word	Byte	Bit 7	Bit 6	Bit 5	Bit 4	Bit 3	Bit 2	Bit 1	Bit 0	
115	0	0	Multi-Function Input 8	Multi-Function Input 7	Multi-Function Input 6	Multi-Function Input 5	Multi-Function Input 4	Multi-Function Input 3	Run Rev	Run Fwd	
		1	Multi-Function Digital Output 3	Multi-Function Digital Output 2	Multi-Function Digital Output 1	-	-	-	Fault Reset	External Fault	
	1	2	Speed Reference (Low Byte)								
		3	Speed Reference (High Byte)								
	2	4	Torque Reference/Torque Limit (Low Byte)								
		5	Torque Reference/Torque Limit (High Byte)								
	3	6	Torque Compensation (Low Byte)								
		7	Torque Compensation (High Byte)								
	4 - 5	8 - 11	Reserved								
	6	12	Analog Output 1 (Low Byte)								
		13	Analog Output 1 (High Byte)								
	7	14	Analog Output 2 (Low Byte)								
		15	Analog Output 2 (High Byte)								
	8	16	Digital Outputs (Low Byte)								

8 Output Assemblies (Drive Consumes)

Output Instance	Word	Byte	Bit 7	Bit 6	Bit 5	Bit 4	Bit 3	Bit 2	Bit 1	Bit 0
		17	Digital Outputs (High Byte)							
	9 - 19	18 - 39	Reserved							

Name	Description
Run Fwd	Forward Run Command 0: Stop 1: Forward Run
Run Rev	Reverse Run Command 0: Stop 1: Reverse Run
Multi-Function Input 3	Terminal S3 Function Input 0: Terminal S3 Function [H1-03] OFF 1: Terminal S3 Function [H1-03] ON
Multi-Function Input 4	Terminal S4 Function Input 0: Terminal S4 Function [H1-04] OFF 1: Terminal S4 Function [H1-04] ON
Multi-Function Input 5	Terminal S5 Function Input 0: Terminal S5 Function [H1-05] OFF 1: Terminal S5 Function [H1-05] ON
Multi-Function Input 6	Terminal S6 Function Input 0: Terminal S6 Function [H1-06] OFF 1: Terminal S6 Function [H1-06] ON
Multi-Function Input 7	Terminal S7 Function Input 0: Terminal S7 Function [H1-07] OFF 1: Terminal S7 Function [H1-07] ON
Multi-Function Input 8	Terminal S8 Function Input 0: Terminal S8 Function [H1-08] OFF 1: Terminal S8 Function [H1-08] ON
External Fault	External Fault EF0 0: - 1: External Fault [EF0]
Fault Reset	Fault Reset 0: - 1: Fault Reset
Multi-Function Digital Output 1	Terminal M1/M2 (varies by drive model) 0: M1/M2 OFF 1: M1/M2 ON This function is enabled only when H2-01 is set to F. Note: The names of the digital outputs are different for different drive series.
Multi-Function Digital Output 2	Terminal M3/M4 (varies by drive model) 0: M3/M4 OFF 1: M3/M4 ON This function is enabled only when H2-02 is set to F. Note: The names of the digital outputs are different for different drive series.
Multi-Function Digital Output 3	Terminal M5/M6 (varies by drive model) 0: M5/M6 OFF 1: M5/M6 ON This function is enabled only when H2-03 is set to F. Note: The names of the digital outputs are different for different drive series.
Speed Reference	Speed Command Sets drive speed reference. Unit is min^{-1} or determined by o1-03.
Torque Reference/Torque Limit	Torque Reference/Torque Limit Sets the Torque Reference/Torque Limit. Sets in units of 0.1%. Sets the Torque Reference when using Torque Control [d5-01 = 1]. Sets the Torque Limit when using Speed Control [d5-01 = 0]. The Torque Reference/Torque Limit are disabled when F6-06 = 0.
Torque Compensation	Torque Compensation Sets the amount of Torque Compensation Sets in units of 0.1%.

Name	Description
Analog Output 1	MEMOBUS/Modbus (0x0007)
Analog Output 2	MEMOBUS/Modbus (0x0008)
Digital Outputs	MEMOBUS/Modbus (0x0009) Note: These values are ORed with values in byte 1.

◆ (Vendor Specific Yaskawa Electric (YE) Assy)-High Speed/Torque Control Output - 116 (0x74)

The first 20 Bytes (0-19) are fixed and the next 20 Bytes can be configured using parameters F7-23 to F7-32. If an error occurs while trying to write to the dynamic parameters, the appropriate error bit in Assembly 166 will be set. If more information is needed as to the nature of the error, the extended error status can be read explicitly through Class 4, Instance 0xA6, Attribute 0x64. This will return 20 Bytes with each dynamic parameter in Assembly 116 having a Byte dedicated to its extended error status.

Output Instance	Word	Byte	Bit 7	Bit 6	Bit 5	Bit 4	Bit 3	Bit 2	Bit 1	Bit 0	
116	0	0	Multi-Function Input 8	Multi-Function Input 7	Multi-Function Input 6	Multi-Function Input 5	Multi-Function Input 4	Multi-Function Input 3	Run Rev	Run Fwd	
		1	Multi-Function Digital Output 3	Multi-Function Digital Output 2	Multi-Function Digital Output 1	-	-	-	Fault Reset	External Fault	
	1	2	Speed Reference (Low Byte)								
		3	Speed Reference (High Byte)								
	2	4	Torque Reference/Torque Limit (Low Byte)								
		5	Torque Reference/Torque Limit (High Byte)								
	3	6	Torque Compensation (Low Byte)								
		7	Torque Compensation (High Byte)								
	4	8	Reserved								
		9	-	-	-	-	Multi-Function Input 12	Multi-Function Input 11	Multi-Function Input 10	Multi-Function Input 9	
	5	10	-	-	-	-	-	-	NetCtrl	NetRef	
		11	-	-	-	-	-	-	-	-	
	6	12	Analog Output 1 (Low Byte)								
		13	Analog Output 1 (High Byte)								
	7	14	Analog Output 2 (Low Byte)								
		15	Analog Output 2 (High Byte)								
	8	16	Digital Outputs (Low Byte)								
		17	Digital Outputs (High Byte)								
	9	18	Reserved								
		19	Reserved								
	10	20 - 21	Dynamic Output 1 [F7-23], Default: Not Used								
	11	22 - 23	Dynamic Output 2 [F7-24], Default: Not Used								
	12	24 - 25	Dynamic Output 3 [F7-25], Default: Not Used								
	13	26 - 27	Dynamic Output 4 [F7-26], Default: Not Used								
	14	28 - 29	Dynamic Output 5 [F7-27], Default: Not Used								
	15	30 - 31	Dynamic Output 6 [F7-28], Default: Not Used								
	16	32 - 33	Dynamic Output 7 [F7-29], Default: Not Used								
	17	34 - 35	Dynamic Output 8 [F7-30], Default: Not Used								
	18	36 - 37	Dynamic Output 9 [F7-31], Default: Not Used								
	19	38 - 39	Dynamic Output 10 [F7-32], Default: Not Used								

8 Output Assemblies (Drive Consumes)

Output Instance	Word	Byte	Bit 7	Bit 6	Bit 5	Bit 4	Bit 3	Bit 2	Bit 1	Bit 0
	20 - 21	40 - 43	Not Used							
Name			Description							
Run Fwd			Forward Run Command 0: Stop 1: Forward Run							
Run Rev			Reverse Run Command 0: Stop 1: Reverse Run							
Multi-Function Input 3			Terminal S3 Function Input 0: Terminal S3 Function [H1-03] OFF 1: Terminal S3 Function [H1-03] ON							
Multi-Function Input 4			Terminal S4 Function Input 0: Terminal S4 Function [H1-04] OFF 1: Terminal S4 Function [H1-04] ON							
Multi-Function Input 5			Terminal S5 Function Input 0: Terminal S5 Function [H1-05] OFF 1: Terminal S5 Function [H1-05] ON							
Multi-Function Input 6			Terminal S6 Function Input 0: Terminal S6 Function [H1-06] OFF 1: Terminal S6 Function [H1-06] ON							
Multi-Function Input 7			Terminal S7 Function Input 0: Terminal S7 Function [H1-07] OFF 1: Terminal S7 Function [H1-07] ON							
Multi-Function Input 8			Terminal S8 Function Input 0: Terminal S8 Function [H1-08] OFF 1: Terminal S8 Function [H1-08] ON							
External Fault			External Fault EF0 0: - 1: External Fault [EF0]							
Fault Reset			Fault Reset 0: - 1: Fault Reset							
Multi-Function Digital Output 1			Terminal M1/M2 (varies by drive model) 0: M1/M2 OFF 1: M1/M2 ON This function is enabled only when H2-01 is set to F. Note: The names of the digital outputs are different for different drive series.							
Multi-Function Digital Output 2			Terminal M3/M4 (varies by drive model) 0: M3/M4 OFF 1: M3/M4 ON This function is enabled only when H2-02 is set to F. Note: The names of the digital outputs are different for different drive series.							
Multi-Function Digital Output 3			Terminal M5/M6 (varies by drive model) 0: M5/M6 OFF 1: M5/M6 ON This function is enabled only when H2-03 is set to F. Note: The names of the digital outputs are different for different drive series.							
Speed Reference			Speed Command Sets drive speed reference. Unit is min^{-1} or determined by o1-03.							
Torque Reference/Torque Limit			Torque Reference/Torque Limit Sets the Torque Reference/Torque Limit. Sets in units of 0.1%. Sets the Torque Reference when using Torque Control [d5-01 = 1]. Sets the Torque Limit when using Speed Control [d5-01 = 0]. The Torque Reference/Torque Limit are disabled when F6-06 = 0.							
Torque Compensation			Torque Compensation Sets the amount of Torque Compensation Sets in units of 0.1%.							
Digital Inputs			Sets digital inputs 9-12 if the drive supports them.							

Name	Description
NetRef	Network sets reference
NetCtrl	Network sets control
Analog Output 1	MEMOBUS/Modbus (0x0007)
Analog Output 2	MEMOBUS/Modbus (0x0008)
Digital Outputs	MEMOBUS/Modbus (0x0009) Note: These values are ORed with values in byte 1.
Dynamic Outputs	Contains the data to be written to the MEMOBUS/Modbus address defined in the given parameter. A value of 0 in the given parameter means it is not used, therefore the value received for this given parameter will not be written to any MEMOBUS/Modbus register. If the PPA is Input Assembly 166, then any errors occurring during a write will be flagged. Refer to page 52 for more information.

◆ (Vendor Specific Yaskawa Electric (YE) Assy) 8 Byte Dynamic Output - 117 (0x75)

Output Instance	Word	Byte	Bit 7	Bit 6	Bit 5	Bit 4	Bit 3	Bit 2	Bit 1	Bit 0	
117	0	0	Multi-Function Input 8	Multi-Function Input 7	Multi-Function Input 6	Multi-Function Input 5	Multi-Function Input 4	Multi-Function Input 3	Run Rev	Run Fwd	
		1	Multi-Function Digital Output 3	Multi-Function Digital Output 2	Multi-Function Digital Output 1	-	-	-	Fault Reset	External Fault	
	1	2	Speed Reference (Low Byte)								
		3	Speed Reference (High Byte)								
	2	4 - 5	Dynamic Output 1 [F7-23], Default: Not Used								
	3	6 - 7	Dynamic Output 2 [F7-24], Default: Not Used								

Name	Description
Run Fwd	Forward Run Command 0: Stop 1: Forward Run
Run Rev	Reverse Run Command 0: Stop 1: Reverse Run
Multi-Function Input 3	Terminal S3 Function Input 0: Terminal S3 Function [H1-03] OFF 1: Terminal S3 Function [H1-03] ON
Multi-Function Input 4	Terminal S4 Function Input 0: Terminal S4 Function [H1-04] OFF 1: Terminal S4 Function [H1-04] ON
Multi-Function Input 5	Terminal S5 Function Input 0: Terminal S5 Function [H1-05] OFF 1: Terminal S5 Function [H1-05] ON
Multi-Function Input 6	Terminal S6 Function Input 0: Terminal S6 Function [H1-06] OFF 1: Terminal S6 Function [H1-06] ON
Multi-Function Input 7	Terminal S7 Function Input 0: Terminal S7 Function [H1-07] OFF 1: Terminal S7 Function [H1-07] ON
Multi-Function Input 8	Terminal S8 Function Input 0: Terminal S8 Function [H1-08] OFF 1: Terminal S8 Function [H1-08] ON
External Fault	External Fault EF0 0: - 1: External Fault [EF0]
Fault Reset	Fault Reset 0: - 1: Fault Reset
Multi-Function Digital Output 1	Terminal M1/M2 (varies by drive model) 0: M1/M2 OFF

8 Output Assemblies (Drive Consumes)

Name	Description
	1: M1/M2 ON This function is enabled only when H2-01 is set to F. Note: The names of the digital outputs are different for different drive series.
Multi-Function Digital Output 2	Terminal M3/M4 (varies by drive model) 0: M3/M4 OFF 1: M3/M4 ON This function is enabled only when H2-02 is set to F. Note: The names of the digital outputs are different for different drive series.
Multi-Function Digital Output 3	Terminal M5/M6 (varies by drive model) 0: M5/M6 OFF 1: M5/M6 ON This function is enabled only when H2-03 is set to F. Note: The names of the digital outputs are different for different drive series.
Speed Reference	Speed Command Sets drive speed reference. Unit is min^{-1} or determined by o1-03. Unit is not affected by Speed Scale SS.
Dynamic Outputs	Contains the data to be written to the MEMOBUS/Modbus address defined in the given parameter. A value of 0 in the given parameter means it is not used, therefore the value received for this given parameter will not be written to any MEMOBUS/Modbus register. If the PPA is Input Assembly 166, then any errors occurring during a write will be flagged. Refer to page 52 for more information.

◆ (Vendor Specific Yaskawa Electric (YE) Assy) 12 Byte Dynamic Output - 118 (0x76)

Output Instance	Word	Byte	Bit 7	Bit 6	Bit 5	Bit 4	Bit 3	Bit 2	Bit 1	Bit 0	
118	0	0	Multi-Function Input 8	Multi-Function Input 7	Multi-Function Input 6	Multi-Function Input 5	Multi-Function Input 4	Multi-Function Input 3	Run Rev	Run Fwd	
		1	Multi-Function Digital Output 3	Multi-Function Digital Output 2	Multi-Function Digital Output 1	-	-	-	Fault Reset	External Fault	
	1	2	Speed Reference (Low Byte)								
		3	Speed Reference (High Byte)								
	2	4 - 5	Dynamic Output 1 [F7-23], Default: Not Used								
	3	6 - 7	Dynamic Output 2 [F7-24], Default: Not Used								
	4	8 - 9	Dynamic Output 3 [F7-25], Default: Not Used								
	5	10 - 11	Dynamic Output 4 [F7-26], Default: Not Used								

Name	Description
Run Fwd	Forward Run Command 0: Stop 1: Forward Run
Run Rev	Reverse Run Command 0: Stop 1: Reverse Run
Multi-Function Input 3	Terminal S3 Function Input 0: Terminal S3 Function [H1-03] OFF 1: Terminal S3 Function [H1-03] ON
Multi-Function Input 4	Terminal S4 Function Input 0: Terminal S4 Function [H1-04] OFF 1: Terminal S4 Function [H1-04] ON
Multi-Function Input 5	Terminal S5 Function Input 0: Terminal S5 Function [H1-05] OFF 1: Terminal S5 Function [H1-05] ON
Multi-Function Input 6	Terminal S6 Function Input 0: Terminal S6 Function [H1-06] OFF 1: Terminal S6 Function [H1-06] ON
Multi-Function Input 7	Terminal S7 Function Input

Name	Description
	0: Terminal S7 Function [H1-07] OFF 1: Terminal S7 Function [H1-07] ON
Multi-Function Input 8	Terminal S8 Function Input 0: Terminal S8 Function [H1-08] OFF 1: Terminal S8 Function [H1-08] ON
External Fault	External Fault EF0 0: - 1: External Fault [EF0]
Fault Reset	Fault Reset 0: - 1: Fault Reset
Multi-Function Digital Output 1	Terminal M1/M2 (varies by drive model) 0: M1/M2 OFF 1: M1/M2 ON This function is enabled only when H2-01 is set to F. Note: The names of the digital outputs are different for different drive series.
Multi-Function Digital Output 2	Terminal M3/M4 (varies by drive model) 0: M3/M4 OFF 1: M3/M4 ON This function is enabled only when H2-02 is set to F. Note: The names of the digital outputs are different for different drive series.
Multi-Function Digital Output 3	Terminal M5/M6 (varies by drive model) 0: M5/M6 OFF 1: M5/M6 ON This function is enabled only when H2-03 is set to F. Note: The names of the digital outputs are different for different drive series.
Speed Reference	Speed Command Sets drive speed reference. Unit is min ⁻¹ or determined by o1-03. Unit is not affected by Speed Scale SS.
Dynamic Outputs	Contains the data to be written to the MEMOBUS/Modbus address defined in the given parameter. A value of 0 in the given parameter means it is not used, therefore the value received for this given parameter will not be written to any MEMOBUS/Modbus register. If the PPA is Input Assembly 166, then any errors occurring during a write will be flagged. Refer to page 52 for more information.

◆ (Vendor Specific Yaskawa Electric (YE) Assy) 18 Byte Dynamic Output - 119 (0x77)

Output Instance	Word	Byte	Bit 7	Bit 6	Bit 5	Bit 4	Bit 3	Bit 2	Bit 1	Bit 0	
119	0	0	Multi-Function Input 8	Multi-Function Input 7	Multi-Function Input 6	Multi-Function Input 5	Multi-Function Input 4	Multi-Function Input 3	Run Rev	Run Fwd	
		1	Multi-Function Digital Output 3	Multi-Function Digital Output 2	Multi-Function Digital Output 1	-	-	-	Fault Reset	External Fault	
	1	2	Speed Reference (Low Byte)								
		3	Speed Reference (High Byte)								
	2	4 - 5	Dynamic Output 1 [F7-23], Default: Not Used								
	3	6 - 7	Dynamic Output 2 [F7-24], Default: Not Used								
	4	8 - 9	Dynamic Output 3 [F7-25], Default: Not Used								
	5	10 - 11	Dynamic Output 4 [F7-26], Default: Not Used								
	6	12 - 13	Dynamic Output 5 [F7-27], Default: Not Used								
	7	14 - 15	Dynamic Output 6 [F7-28], Default: Not Used								
8	16 - 17	Dynamic Output 7 [F7-29], Default: Not Used									

8 Output Assemblies (Drive Consumes)

Name	Description
Run Fwd	Forward Run Command 0: Stop 1: Forward Run
Run Rev	Reverse Run Command 0: Stop 1: Reverse Run
Multi-Function Input 3	Terminal S3 Function Input 0: Terminal S3 Function [H1-03] OFF 1: Terminal S3 Function [H1-03] ON
Multi-Function Input 4	Terminal S4 Function Input 0: Terminal S4 Function [H1-04] OFF 1: Terminal S4 Function [H1-04] ON
Multi-Function Input 5	Terminal S5 Function Input 0: Terminal S5 Function [H1-05] OFF 1: Terminal S5 Function [H1-05] ON
Multi-Function Input 6	Terminal S6 Function Input 0: Terminal S6 Function [H1-06] OFF 1: Terminal S6 Function [H1-06] ON
Multi-Function Input 7	Terminal S7 Function Input 0: Terminal S7 Function [H1-07] OFF 1: Terminal S7 Function [H1-07] ON
Multi-Function Input 8	Terminal S8 Function Input 0: Terminal S8 Function [H1-08] OFF 1: Terminal S8 Function [H1-08] ON
External Fault	External Fault EF0 0: - 1: External Fault [EF0]
Fault Reset	Fault Reset 0: - 1: Fault Reset
Multi-Function Digital Output 1	Terminal M1/M2 (varies by drive model) 0: M1/M2 OFF 1: M1/M2 ON This function is enabled only when H2-01 is set to F. Note: The names of the digital outputs are different for different drive series.
Multi-Function Digital Output 2	Terminal M3/M4 (varies by drive model) 0: M3/M4 OFF 1: M3/M4 ON This function is enabled only when H2-02 is set to F. Note: The names of the digital outputs are different for different drive series.
Multi-Function Digital Output 3	Terminal M5/M6 (varies by drive model) 0: M5/M6 OFF 1: M5/M6 ON This function is enabled only when H2-03 is set to F. Note: The names of the digital outputs are different for different drive series.
Speed Reference	Speed Command Sets drive speed reference. Unit is min^{-1} or determined by o1-03. Unit is not affected by Speed Scale SS.
Dynamic Outputs	Contains the data to be written to the MEMOBUS/Modbus address defined in the given parameter. A value of 0 in the given parameter means it is not used, therefore the value received for this given parameter will not be written to any MEMOBUS/Modbus register. If the PPA is Input Assembly 166, then any errors occurring during a write will be flagged. Refer to page 52 for more information.

◆ (Vendor Specific Yaskawa Electric (YE) Assy) 24 Byte Dynamic Output - 120 (0x78)

Output Instance	Word	Byte	Bit 7	Bit 6	Bit 5	Bit 4	Bit 3	Bit 2	Bit 1	Bit 0
120	0	0	Multi-Function Input 8	Multi-Function Input 7	Multi-Function Input 6	Multi-Function Input 5	Multi-Function Input 4	Multi-Function Input 3	Run Rev	Run Fwd

Output Instance	Word	Byte	Bit 7	Bit 6	Bit 5	Bit 4	Bit 3	Bit 2	Bit 1	Bit 0
		1	Multi-Function Digital Output 3	Multi-Function Digital Output 2	Multi-Function Digital Output 1	-	-	-	Fault Reset	External Fault
1		2	Speed Reference (Low Byte)							
		3	Speed Reference (High Byte)							
2		4 - 5	Dynamic Output 1 [F7-23], Default: Not Used							
3		6 - 7	Dynamic Output 2 [F7-24], Default: Not Used							
4		8 - 9	Dynamic Output 3 [F7-25], Default: Not Used							
5		10 - 11	Dynamic Output 4 [F7-26], Default: Not Used							
6		12 - 13	Dynamic Output 5 [F7-27], Default: Not Used							
7		14 - 15	Dynamic Output 6 [F7-28], Default: Not Used							
8		16 - 17	Dynamic Output 7 [F7-29], Default: Not Used							
9		18 - 19	Dynamic Output 8 [F7-30], Default: Not Used							
10		20 - 21	Dynamic Output 9 [F7-31], Default: Not Used							
11		22 - 23	Dynamic Output 10 [F7-32], Default: Not Used							

Name	Description
Run Fwd	Forward Run Command 0: Stop 1: Forward Run
Run Rev	Reverse Run Command 0: Stop 1: Reverse Run
Multi-Function Input 3	Terminal S3 Function Input 0: Terminal S3 Function [H1-03] OFF 1: Terminal S3 Function [H1-03] ON
Multi-Function Input 4	Terminal S4 Function Input 0: Terminal S4 Function [H1-04] OFF 1: Terminal S4 Function [H1-04] ON
Multi-Function Input 5	Terminal S5 Function Input 0: Terminal S5 Function [H1-05] OFF 1: Terminal S5 Function [H1-05] ON
Multi-Function Input 6	Terminal S6 Function Input 0: Terminal S6 Function [H1-06] OFF 1: Terminal S6 Function [H1-06] ON
Multi-Function Input 7	Terminal S7 Function Input 0: Terminal S7 Function [H1-07] OFF 1: Terminal S7 Function [H1-07] ON
Multi-Function Input 8	Terminal S8 Function Input 0: Terminal S8 Function [H1-08] OFF 1: Terminal S8 Function [H1-08] ON
External Fault	External Fault EF0 0: - 1: External Fault [EF0]
Fault Reset	Fault Reset 0: - 1: Fault Reset
Multi-Function Digital Output 1	Terminal M1/M2 (varies by drive model) 0: M1/M2 OFF 1: M1/M2 ON This function is enabled only when H2-01 is set to F. Note: The names of the digital outputs are different for different drive series.
Multi-Function Digital Output 2	Terminal M3/M4 (varies by drive model) 0: M3/M4 OFF 1: M3/M4 ON This function is enabled only when H2-02 is set to F. Note: The names of the digital outputs are different for different drive series.

8 Output Assemblies (Drive Consumes)

Name	Description
Multi-Function Digital Output 3	Terminal M5/M6 (varies by drive model) 0: M5/M6 OFF 1: M5/M6 ON This function is enabled only when H2-03 is set to F. Note: The names of the digital outputs are different for different drive series.
Speed Reference	Speed Command Sets drive speed reference. Unit is min ⁻¹ or determined by o1-03. Unit is not affected by Speed Scale SS.
Dynamic Outputs	Contains the data to be written to the MEMOBUS/Modbus address defined in the given parameter. A value of 0 in the given parameter means it is not used, therefore the value received for this given parameter will not be written to any MEMOBUS/Modbus register. If the PPA is Input Assembly 166, then any errors occurring during a write will be flagged. Refer to page 52 for more information.

◆ (Vendor Specific Yaskawa Electric (YE) Assy) Gateway Consume Assembly - 130 (0x82)

Note:

This assembly will not work on drives or bypass units that do not support the gateway functionality. Refer to the instruction manual of your specific drive for more information.

The drive reads the values of parameters *F7-23 to F7-32 [Dynamic Out Param 1 to 10 for CommCard]* on power-up or after a reset. You must cycle power on the drive or reset the software on the option to change these parameter values.

The master drive control and frequency reference registers are written immediately. Slave drive registers 15C5 (Hex.) through 15D0 (Hex.) are written after the network data for these registers change. The maximum rate that it will write is every 250 ms.

Output Instance	Word	Byte	Modbus Address (Hex.)	Bit 7	Bit 6	Bit 5	Bit 4	Bit 3	Bit 2	Bit 1	Bit 0	
130	0	0 - 1	0001	Control Word (Drive or Master)								
	1	2 - 3	0002	Frequency Reference (Drive or Master)								
	2	4 - 5	15C5	Source Update Register								
	3	6 - 7	15C6	Slave Drive 1 Control Word								
	4	8 - 9	15C7	Slave Drive 1 Frequency Reference								
	5	10 - 11	15C8	Slave Drive 2 Control Word								
	6	12 - 13	15C9	Slave Drive 2 Frequency Reference								
	7	14 - 15	15CA	Slave Drive 3 Control Word								
	8	16 - 17	15CB	Slave Drive 3 Frequency Reference								
	9	18 - 19	15CC	Slave Drive 4 Control Word								
	10	20 - 21	15CD	Slave Drive 4 Frequency Reference								
				Modbus Window Command								
	11	22 - 23	15CE	-	-	-	0: Read 1: Write	Drive Select 0: Broadcast 1: Drive 1 2: Drive 2 3: Drive 3 4: Drive 4 5: Run command and frequency reference broadcast				
	12	24 - 25	15CF	Modbus Window Register								
	13	26 - 27	15D0	Modbus Window Data								
	14	28 - 29	Configurable (F7-23)	Dynamic Output 1								
15	30 - 31	Configurable (F7-24)	Dynamic Output 2									
16	32 - 33	Configurable (F7-25)	Dynamic Output 3									

Output Instance	Word	Byte	Modbus Address (Hex.)	Bit 7	Bit 6	Bit 5	Bit 4	Bit 3	Bit 2	Bit 1	Bit 0
	17	34 - 35	Configurable (F7-26)	Dynamic Output 4							
	18	36 - 37	Configurable (F7-27)	Dynamic Output 5							
	19	38 - 39	Configurable (F7-28)	Dynamic Output 6							
	20	40 - 41	Configurable (F7-29)	Dynamic Output 7							
	21	42 - 43	Configurable (F7-30)	Dynamic Output 8							
	22	44 - 45	Configurable (F7-31)	Dynamic Output 9							
	23	46 - 47	Configurable (F7-32)	Dynamic Output 10							

Name	Description
Dynamic Outputs	Contains the data to be written to the MEMOBUS/Modbus address defined in the given parameter. A value of 0 in the given parameter means it is not used, therefore the value received for this given parameter will not be written to any MEMOBUS/Modbus register. If the PPA is Input Assembly 166, then any errors occurring during a write will be flagged. Refer to page 52 for more information.

9 Input Assemblies (Drive Produces)

Note:

The convention in this manual is from the PLC perspective. An “Input Assembly” is outputted from this node and read by the PLC. This section details “Input Assemblies” that are “Produced” by the drive.

◆ EtherNet/IP Basic Speed Control Input - 70 (0x46)

Input Instance	Word	Byte	Bit 7	Bit 6	Bit 5	Bit 4	Bit 3	Bit 2	Bit 1	Bit 0	
70	0	0	-	-	-	-	-	Running 1 (FWD)	-	Faulted	
		1	-								
	1	2	Speed Actual (Low Byte)								
		3	Speed Actual (High Byte)								

Name	Description
Faulted	Faulted 0: No Fault 1: Fault
Running 1 (FWD)	Forward Running 0: Stop or Reverse Running 1: Forward Running
Speed Actual	Actual Drive Speed Monitors drive output frequency. Speed actual data: Output frequency x 2 ^{SS} (SS: Speed scale) Range: 0 - FFFF (Hex.) For example, when output frequency of 1024 with a speed scale of 2: Speed actual data = 1024 x 2 ² = 4096 = 1000 (Hex.) Unit depends on o1-03.

◆ EtherNet/IP Extended Speed Control Input - 71 (0x47)

Input Instance	Word	Byte	Bit 7	Bit 6	Bit 5	Bit 4	Bit 3	Bit 2	Bit 1	Bit 0	
71	0	0	Speed Agree	NetRef	NetCtrl	Ready	Running 2 (REV)	Running 1 (FWD)	Alarm	Faulted	
		1	State								
	1	2	Speed Actual (Low Byte)								
		3	Speed Actual (High Byte)								

9 Input Assemblies (Drive Produces)

Name	Description
Faulted	Faulted 0: No Fault 1: Fault
Alarm	Alarm 0: No Alarm 1: Alarm
Running 1 (FWD)	Forward Running 0: Stop or Reverse Running 1: Forward Running
Running 2 (REV)	Reverse Running 0: Stop or Forward Running 1: Reverse Running
Ready	Ready 0: Not Ready 1: Ready
NetCtrl	Run command is from network 0: Run command is not from network 1: Run command is from network
NetRef	Speed reference is from network 0: Speed reference is not from network 1: Speed reference is from network
Speed Agree	Speed Agree 0: - 1: Speed actual at speed reference
State	Contains the value from the Control Supervisor (Class 0x29) Instance 1 Attribute 6.
Speed Actual	Actual Drive Speed Monitors drive output frequency. Speed actual data: Output frequency x 2 ^{SS} (SS: Speed scale) Range: 0 - FFFF (Hex.) For example, when output frequency of 1024 with a speed scale of 2: Speed actual data = 1024 x 2 ² = 4096 = 0x1000 Unit depends on o1-03.

◆ EtherNet/IP Speed and Torque Control Input - 72 (0x48)

Input Instance	Word	Byte	Bit 7	Bit 6	Bit 5	Bit 4	Bit 3	Bit 2	Bit 1	Bit 0	
72	0	0	-	-	-	-	-	Running 1 (FWD)	-	Faulted	
		1	-								
	1	2	Speed Actual (Low Byte)								
		3	Speed Actual (High Byte)								
	2	4	Torque Actual (Low Byte)								
		5	Torque Actual (High Byte)								

Name	Description
Faulted	Faulted 0: No Fault 1: Fault
Running 1 (FWD)	Forward Running 0: Stop or Reverse Running 1: Forward Running
Speed Actual	Actual Drive Speed Monitors drive output frequency. Speed actual data: Output frequency x 2 ^{SS} (SS: Speed scale) Range: 0 - FFFF (Hex.) For example, when output frequency of 1024 with a speed scale of 2: Speed actual data = 1024 x 2 ² = 4096 = 1000 (Hex.) Unit depends on o1-03.
Torque Actual	Output Torque Shows the Torque Reference. Value displays in 0.1% units.

◆ EtherNet/IP Extended Speed and Torque Control Input - 73 (0x49)

Input Instance	Word	Byte	Bit 7	Bit 6	Bit 5	Bit 4	Bit 3	Bit 2	Bit 1	Bit 0	
73	0	0	Speed Agree	NetRef	NetCtrl	Ready	Running 2 (REV)	Running 1 (FWD)	Alarm	Faulted	
		1	State								
	1	2	Speed Actual (Low Byte)								
		3	Speed Actual (High Byte)								
	2	4	Torque Actual (Low Byte)								
		5	Torque Actual (High Byte)								

Name	Description
Faulted	Faulted 0: No Fault 1: Fault
Alarm	Alarm 0: No Alarm 1: Alarm
Running 1 (FWD)	Forward Running 0: Stop or Reverse Running 1: Forward Running
Running 2 (REV)	Reverse Running 0: Stop or Forward Running 1: Reverse Running
Ready	Ready 0: Not Ready 1: Ready
NetCtrl	Run command is from network 0: Run command is not from network 1: Run command is from network
NetRef	Speed reference is from network 0: Speed reference is not from network 1: Speed reference is from network
Speed Agree	Speed Agree 0: - 1: Speed actual at speed reference
State	Contains the value from the Control Supervisor (Class 0x29) Instance 1 Attribute 6.
Speed Actual	Actual Drive Speed Monitors drive output frequency. Speed actual data: Output frequency x 2 ^{SS} (SS: Speed scale) Range: 0 - FFFF (Hex.) For example, when output frequency of 1024 with a speed scale of 2: Speed actual data = 1024 x 2 ² = 4096 = 1000 (Hex.) Unit depends on o1-03.
Torque Actual	Output Torque Shows the Torque Reference. Value displays in 0.1% units.

◆ (Vendor Specific Yaskawa Electric (YE) Assy) MEMOBUS/Modbus Message Input - 150 (0x96)

Input Instance	Word	Byte	Bit 7	Bit 6	Bit 5	Bit 4	Bit 3	Bit 2	Bit 1	Bit 0	
150	0	0	Function Code								
		1	Register Number (High Byte)								
	1	2	Register Number (Low Byte)								
		3	Register Data (High Byte)								
	2	4	Register Data (Low Byte)								

9 Input Assemblies (Drive Produces)

Note:

This is a paired assembly (100/150).

Table 9.1 Reply Mapping - 150

Byte	Write Success	Read Success	Write Failure	Read Failure	Invalid Function Code	Function Code Equals Zero
0	0x10	0x03	0x90	0x83	Function Code Or-ed with 0x80	0
1	Output Assembly Register Number (High Byte)	Output Assembly Register Number (High Byte)	Output Assembly Register Number (High Byte)	Output Assembly Register Number (High Byte)	Output Assembly Register Number (High Byte)	0
2	Output Assembly Register Number (Low Byte)	Output Assembly Register Number (Low Byte)	Output Assembly Register Number (Low Byte)	Output Assembly Register Number (Low Byte)	Output Assembly Register Number (Low Byte)	0
3	0	Read Data (High Byte)	0	0	0	0
4	0	Read Data (Low Byte)	Error Code	Error Code	1	0

Table 9.2 Error Replies - 150

Error Code	Description
0x01	Invalid Function Code
0x02	Invalid Register Number
0x21	Upper/Lower Limit Error
0x22	Write Mode Error Option generated busy event. The MEMOBUS/Modbus requested operation is in the process loop but the drive is not done yet. Writing "Enter" when drive is running. Attempt to write data that is read only. Attempt to write a parameter when drive is running. During a CPF03 event attempting to write to registers other than A1-00 to A1-05, E1-03, o2-04.
0x23	Writing Error during Undervoltage Attempting to write during a drive Uv [undervoltage] event.
0x24	Writing Error during Parameter Processing Attempting to write while the drive is storing data.

Note:

Refer to the MEMOBUS/Modbus Data Table in Appendix C of the drive Technical Manual for a list of monitor data using the MEMOBUS/Modbus message area.

◆ (Vendor Specific Yaskawa Electric (YE) Assy) Speed/Torque Status Input - 151 (0x97)

Input Instance	Word	Byte	Bit 7	Bit 6	Bit 5	Bit 4	Bit 3	Bit 2	Bit 1	Bit 0	
151	0	0	Faulted	Alarm	Ready	Speed Agree	Reset	REV Running	ZSP	Running	
		1	ZSV	-	Multi-Function Digital Output 3	Multi-Function Digital Output 2	Multi-Function Digital Output 1	LOCAL/REMOTE	Uv	oPE	
	1	2	Output Frequency (Low Byte)								
		3	Output Frequency (High Byte)								
	2	4	Torque Actual (Low Byte)								
		5	Torque Actual (High Byte)								
	3	6	Current Actual (Low Byte)								
		7	Current Actual (High Byte)								

Name	Description
Running	Running 0: Stop 1: Forward or Reverse Running
ZSP	Zero Speed 0: Running 1: Stop or DC Injection Braking
REV Running	Reverse Running 0: Not Reverse Running

Name	Description
	1: Reverse Running
Reset	Reset 0: - 1: Reset
Speed Agree	Speed Agree 0: - 1: Speed actual at speed reference
Ready	Ready 0: Not Ready 1: Ready
Alarm	Alarm 0: No Alarm 1: Alarm
Faulted	Faulted 0: No Fault 1: Fault
oPE	oPE 0: - 1: oPExx
Uv	Undervoltage 0: - 1: Undervoltage
LOCAL/REMOTE	Run command is from network 0: Run command is not from network 1: Run command is from network
Multi-Function Digital Output 1	Terminal M1/M2 (varies by drive model) 0: M1/M2 OFF 1: M1/M2 ON This function is enabled only when H2-01 is set to F. Note: The names of the digital outputs are different for different drive series.
Multi-Function Digital Output 2	Terminal M3/M4 (varies by drive model) 0: M3/M4 OFF 1: M3/M4 ON This function is enabled only when H2-02 is set to F. Note: The names of the digital outputs are different for different drive series.
Multi-Function Digital Output 3	Terminal M5/M6 (varies by drive model) 0: M5/M6 OFF 1: M5/M6 ON This function is enabled only when H2-03 is set to F. Note: The names of the digital outputs are different for different drive series.
ZSV	Zero Servo Completed 0: - 1: Zero Servo Completed
Output Frequency	Actual Drive Speed Monitors drive output frequency. Unit depends on o1-03. Unit is not affected by Speed Scale SS.
Torque Actual	Output Torque Shows the Torque Reference. Value displays in 0.1% units.
Current Actual	Actual Output Current Monitors drive output current. Unit: 0.1 A Unit is not affected by Current Scale CS.

◆ (Vendor Specific Yaskawa Electric (YE) Assy) Extended Speed/Torque Status Input - 155 (0x9B)

Input Instance	Word	Byte	Bit 7	Bit 6	Bit 5	Bit 4	Bit 3	Bit 2	Bit 1	Bit 0	
155	0	0	Faulted	Alarm	Ready	Speed Agree	Fault Reset	REV Running	ZSP	Running	
		1	ZSV	-	Multi-Function Digital Output 3	Multi-Function Digital Output 2	Multi-Function Digital Output 1	LOCAL/REMOTE	Uv	oPE	
	1	2	Motor Speed (Low Byte)								
		3	Motor Speed (High Byte)								
	2	4	Torque Actual (Low Byte)								
		5	Torque Actual (High Byte)								
	3	6	PG Count Value (Low Byte)								
		7	PG Count Value (High Byte)								
	4	8	Frequency Command (Low Byte)								
		9	Frequency Command (High Byte)								
	5	10	Output Frequency (Low Byte)								
		11	Output Frequency (High Byte)								
	6	12	Output Current (Low Byte)								
		13	Output Current (High Byte)								
	7	14	Terminal A2 Input (Low Byte)								
		15	Terminal A2 Input (High Byte)								
	8	16	Main Circuit DC Voltage (Low Byte)								
		17	Main Circuit DC Voltage (High Byte)								
	9	18	Error Alarm Signal 1 (Low Byte)								
		19	Error Alarm Signal 1 (High Byte)								
	10	20	Error Alarm Signal 2 (Low Byte)								
		21	Error Alarm Signal 2 (High Byte)								
	11	22	Error Alarm Signal 3 (Low Byte)								
		23	Error Alarm Signal 3 (High Byte)								
	12	24	Terminal A3 Input (Low Byte)								
		25	Terminal A3 Input (High Byte)								
	13	26	Terminal S1 to S8 Input (Low Byte)								
		27	Terminal S1 to S8 Input (High Byte)								
	14	28	Terminal A1 Input (Low Byte)								
		29	Terminal A1 Input (High Byte)								
	15	30	PG Counter (Ch2) (Low Byte)								
		31	PG Counter (Ch2) (High Byte)								
16 - 19	32 - 39	Reserved									

Name	Description
Running	Running 0: Stop 1: Forward or Reverse Running
ZSP	Zero Speed 0: Running 1: Stop or DC Injection Braking
REV Running	Reverse Running 0: Not Reverse Running 1: Reverse Running
Fault Reset	Fault Reset 0: -

Name	Description
	1: Fault Reset
Speed Agree	Speed Agree 0: - 1: Speed actual at speed reference
Ready	Ready 0: Not Ready 1: Ready
Alarm	Alarm 0: No Alarm 1: Alarm
Faulted	Faulted 0: No Fault 1: Fault
oPE	oPE 0: - 1: oPExx
Uv	Undervoltage 0: - 1: Undervoltage
LOCAL/REMOTE	Run command is from network 0: Run command is not from network 1: Run command is from network
Multi-Function Digital Output 1	Terminal M1/M2 (varies by drive model) 0: M1/M2 OFF 1: M1/M2 ON This function is enabled only when H2-01 is set to F. Note: The names of the digital outputs are different for different drive series.
Multi-Function Digital Output 2	Terminal M3/M4 (varies by drive model) 0: M3/M4 OFF 1: M3/M4 ON This function is enabled only when H2-02 is set to F. Note: The names of the digital outputs are different for different drive series.
Multi-Function Digital Output 3	Terminal M5/M6 (varies by drive model) 0: M5/M6 OFF 1: M5/M6 ON This function is enabled only when H2-03 is set to F. Note: The names of the digital outputs are different for different drive series.
ZSV	Zero Servo Completed 0: - 1: Zero Servo Completed
Motor Speed	Monitor parameter U1-05
Torque Actual	Output Torque Shows the torque reference. Value displays in 0.1% units.
PG Count Value	MEMOBUS/Modbus (0x7CD) PG1 Count value register U6-18
Frequency Command	Monitor parameter U1-01
Output Frequency	Actual Drive Speed Monitors drive output frequency. Unit depends on o1-03. Unit is not affected by Speed Scale SS.
Output Current	Actual Output Current Monitors drive output current. Unit: 0.01A Unit is not affected by Current Scale CS.
Terminal A2 Input	MEMOBUS/Modbus (0x4F) Monitor parameter U1-14
Main Circuit DC Voltage	Main Circuit DC Voltage Monitor parameter U1-07

9 Input Assemblies (Drive Produces)

Name	Description
Error Alarm Signal 1	Error Alarm Signal 1 MEMOBUS/Modbus (0xC8)
Error Alarm Signal 2	Error Alarm Signal 2 MEMOBUS/Modbus (0xC9)
Error Alarm Signal 3	Error Alarm Signal 3 MEMOBUS/Modbus (0xCA)
Terminal A3 Input	MEMOBUS/Modbus (0x50) Monitor parameter U1-15
Terminal S1 to S8 Input	MEMOBUS/Modbus (0x49) Monitor parameter U1-10
Terminal A1 Input	MEMOBUS/Modbus (0x46) Monitor parameter U1-13
PG Counter (Ch2)	MEMOBUS/Modbus (0x7E5) PG Pulse Count for Channel 2 U6-19

◆ (Vendor Specific Yaskawa Electric (YE) Assy) High Speed/Torque Status Input - 166 (0xA6)

If an error occurs while trying to read from the dynamic parameters, the appropriate error bit in Assembly 166 will be set. If more information about the nature of the error is needed, the extended error status can be read explicitly through Class 4, Instance 0xA6, Attribute 0x64. This will return 20 Bytes with each dynamic parameter in Assembly 166 having a Byte dedicated to its extended error status.

Input Instance	Word	Byte	Bit 7	Bit 6	Bit 5	Bit 4	Bit 3	Bit 2	Bit 1	Bit 0	
166	0	0	Faulted	Alarm	Ready	Speed Agree	Fault Reset	REV Running	ZSP	Running	
		1	ZSV	-	Multi-Function Digital Output 3	Multi-Function Digital Output 2	Multi-Function Digital Output 1	LOCAL/REMOTE	Uv	oPE	
	1	2	Motor Speed (Low Byte)								
		3	Motor Speed (High Byte)								
	2	4	Torque Actual (Low Byte)								
		5	Torque Actual (High Byte)								
	3	6	PG Count Value (Low Byte)								
		7	PG Count Value (High Byte)								
	4	8	Frequency Command (Low Byte)								
		9	Frequency Command (High Byte)								
	5	10	Output Frequency (Low Byte)								
		11	Output Frequency (High Byte)								
	6	12	Output Current (Low Byte)								
		13	Output Current (High Byte)								
	7	14	Parameter [F7-35], Default: Terminal A1 Input (Low Byte)								
		15	Parameter [F7-35], Default: Terminal A1 Input (High Byte)								
	8	16	Main Circuit DC Voltage (Low Byte)								
		17	Main Circuit DC Voltage (High Byte)								
	9	18	Error Code (Low Byte)								
		19	Error Code (High Byte)								
	10 *I	20 *I	Parameter [F7-33], Default: Alarm Code (Low Byte)								
		21 *I	Parameter [F7-33], Default: Alarm Code (High Byte)								
	11 *I	22 *I	Parameter [F7-34], Default: Output Power (Low Byte)								
		23 *I	Parameter [F7-34], Default: Output Power (High Byte)								
	12 *I	24 *I	Parameter [F7-35], Default: Terminal A2 Input (Low Byte)								
25 *I		Parameter [F7-35], Default: Terminal A2 Input (High Byte)									

Input Instance	Word	Byte	Bit 7	Bit 6	Bit 5	Bit 4	Bit 3	Bit 2	Bit 1	Bit 0
13 */	26 */	Parameter [F7-36], Default: Terminal S1 to S8 Input (Low Byte)								
	27 */	Parameter [F7-36], Default: Terminal S1 to S8 Input (High Byte)								
14 */	28 */	Parameter [F7-37], Default: Terminal A3 Input (Low Byte)								
	29 */	Parameter [F7-37], Default: Terminal A3 Input (High Byte)								
15 */	30 */	Parameter [F7-38], Default: PG Counter (Ch2) (Low Byte)								
	31 */	Parameter [F7-38], Default: PG Counter (Ch2) (High Byte)								
16 */	32 */	-	-	-	-	-	-	-	NetCtrl	NetRef
	33 */	Parameter [F7-39], Default: NetRef and NetCtrl (High Byte)								
17 */	34 */	Parameter [F7-40], Default: Drive Software Version (Low Byte)								
	35 */	Parameter [F7-40], Default: Drive Software Version (High Byte)								
18 */	36 */	Parameter [F7-41] (Low Byte), Default: Not Used								
	37 */	Parameter [F7-41] (High Byte), Default: Not Used								
19 */	38 */	Parameter [F7-42] (Low Byte), Default: Not Used								
	39 */	Parameter [F7-42] (High Byte), Default: Not Used								
20	40	-	-	-	-	-	-	-	Assy. 116 F7-32 Error	Assy. 116 F7-31 Error
	41	Assy. 116 F7-30 Error	Assy. 116 F7-29 Error	Assy. 116 F7-28 Error	Assy. 116 F7-27 Error	Assy. 116 F7-26 Error	Assy. 116 F7-25 Error	Assy. 116 F7-24 Error	Assy. 116 F7-23 Error	Assy. 116 F7-22 Error
21	42	-	-	-	-	-	-	-	Assy. 166 F7-42 Error	Assy. 166 F7-41 Error
	43	Assy. 166 F7-40 Error	Assy. 166 F7-39 Error	Assy. 166 F7-38 Error	Assy. 166 F7-37 Error	Assy. 166 F7-36 Error	Assy. 166 F7-35 Error	Assy. 166 F7-34 Error	Assy. 166 F7-33 Error	Assy. 166 F7-32 Error

*1 Selectable with F7-33 to F7-42.

Name	Description
Running	Running 0: Stop 1: Forward or Reverse Running
ZSP	Zero Speed 0: Running 1: Stop or DC Injection Braking
REV Running	Reverse Running 0: Not Reverse Running 1: Reverse Running
Fault Reset	Fault Reset 0: - 1: Fault Reset
Speed Agree	Speed Agree 0: - 1: Speed actual at speed reference
Ready	Ready 0: Not Ready 1: Ready
Alarm	Alarm 0: No Alarm 1: Alarm
Faulted	Faulted 0: No Fault 1: Fault
oPE	oPE 0: - 1: oPExx
Uv	Undervoltage 0: - 1: Undervoltage
LOCAL/REMOTE	Run command is from network

9 Input Assemblies (Drive Produces)

Name	Description
	0: Run command is not from network 1: Run command is from network
Multi-Function Digital Output 1	Terminal M1/M2 (varies by drive model) 0: M1/M2 OFF 1: M1/M2 ON This function is enabled only when H2-01 is set to F. Note: The names of the digital outputs are different for different drive series.
Multi-Function Digital Output 2	Terminal M3/M4 (varies by drive model) 0: M3/M4 OFF 1: M3/M4 ON This function is enabled only when H2-02 is set to F. Note: The names of the digital outputs are different for different drive series.
Multi-Function Digital Output 3	Terminal M5/M6 (varies by drive model) 0: M5/M6 OFF 1: M5/M6 ON This function is enabled only when H2-03 is set to F. Note: The names of the digital outputs are different for different drive series.
ZSV	Zero Servo Completed 0: - 1: Zero Servo Completed
Motor Speed	Monitor parameter U1-05
Torque Actual	Output Torque Shows the Torque Reference. Value displays in 0.1% units.
PG Count Value	Contained MEMOBUS/Modbus Address PG1 Count value register (0xF0)
Frequency Command	Monitor parameter U1-01
Output Frequency	Actual Drive Speed Monitors drive output frequency. Unit depends on o1-03. Unit is not affected by Speed Scale SS.
Output Current	Actual Output Current Monitors drive output current. Unit: 0.01A Unit is not affected by Current Scale CS.
Terminal A1 Input	MEMOBUS/Modbus (0x46) Monitor parameter U1-13
Main Circuit DC Voltage	Main Circuit DC Voltage Monitor parameter U1-07
Error Code	U2-01 converted using fault code table.
F7-33 Alarm Code	Programmable: MEMOBUS/Modbus (0x7F)
F7-34 Output Power	Programmable: MEMOBUS/Modbus (0x47) Monitor parameter U1-08
F7-35 Terminal A2 Input	Programmable: MEMOBUS/Modbus (0x4F) Monitor parameter U1-14
F7-36 Terminal S1 to S8	Programmable: MEMOBUS/Modbus (0x49) Monitor parameter U1-10
F7-37 Terminal A3 Input	Programmable: MEMOBUS/Modbus (0x50)
F7-38 PG Count Value (Ch2)	Programmable: MEMOBUS/Modbus (0x7E5) PG Pulse Count for Channel 2 U6-19
F7-39 NetRef (Status)	Speed reference is from network 0: Speed reference is not from network 1: Speed reference is from network
F7-40 Drive Software Version	Programmable: MEMOBUS/Modbus (0x4D) Monitor parameter U1-25

Possible extended error codes are listed in [Table 9.3](#) and [Table 9.4](#). If an error occurs, extended error code 0x02 (Register number failure) is usually set.

Table 9.3 Extended Error Codes for Assembly 116/166

Error Code	Description
0x00	No Fault
0x01	Sub function code failure
0x02	Register Number
0x21	Limit check error failure
0x22	Write Failure
0x23	Write failure at Uv
0x24	Write failure at busy

Table 9.4 Extended Error Codes in Class 0x04, Instance 0xA6, Attribute 0x64

Dynamic Parameter	Byte Containing Extended Error Code
F7-23	Byte 0
F7-24	Byte 1
F7-25	Byte 2
F7-26	Byte 3
F7-27	Byte 4
F7-28	Byte 5
F7-29	Byte 6
F7-30	Byte 7
F7-31	Byte 8
F7-32	Byte 9
F7-33	Byte 10
F7-34	Byte 11
F7-35	Byte 12
F7-36	Byte 13
F7-37	Byte 14
F7-38	Byte 15
F7-39	Byte 16
F7-40	Byte 17
F7-41	Byte 18
F7-42	Byte 19

◆ (Vendor Specific Yaskawa Electric (YE) Assy) 8-Byte Dynamic Input - 167 (0xA7)

Input Instance	Word	Byte	Bit 7	Bit 6	Bit 5	Bit 4	Bit 3	Bit 2	Bit 1	Bit 0	
167	0	0	Faulted	Alarm	Ready	Speed Agree	Fault Reset	REV Running	ZSP	Running	
		1	ZSV	-	Multi-Function Digital Output 3	Multi-Function Digital Output 2	Multi-Function Digital Output 1	LOCAL/REMOTE	Uv	oPE	
	1	2	Output Frequency (Low Byte)								
		3	Output Frequency (High Byte)								
	2	4 - 5	Dynamic Input 1 [F7-33], Default: Alarm Code								
	3	6 - 7	Dynamic Input 2 [F7-34], Default: Output Power [U1-08]								

Name	Description
Running	Running 0: Stop 1: Forward or Reverse Running
ZSP	Zero Speed

9 Input Assemblies (Drive Produces)

Name	Description
	0: Running 1: Stop or DC Injection Braking
REV Running	Reverse Running 0: Not Reverse Running 1: Reverse Running
Fault Reset	Fault Reset 0: - 1: Fault Reset
Speed Agree	Speed Agree 0: - 1: Speed actual at speed reference
Ready	Ready 0: Not Ready 1: Ready
Alarm	Alarm 0: No Alarm 1: Alarm
Faulted	Faulted 0: No Fault 1: Fault
oPE	oPE 0: - 1: oPExx
Uv	Undervoltage 0: - 1: Undervoltage
LOCAL/REMOTE	Run command is from network 0: Run command is not from network 1: Run command is from network
Multi-Function Digital Output 1	Terminal M1/M2 (varies by drive model) 0: M1/M2 OFF 1: M1/M2 ON This function is enabled only when H2-01 is set to F. Note: The names of the digital outputs are different for different drive series.
Multi-Function Digital Output 2	Terminal M3/M4 (varies by drive model) 0: M3/M4 OFF 1: M3/M4 ON This function is enabled only when H2-02 is set to F. Note: The names of the digital outputs are different for different drive series.
Multi-Function Digital Output 3	Terminal M5/M6 (varies by drive model) 0: M5/M6 OFF 1: M5/M6 ON This function is enabled only when H2-03 is set to F. Note: The names of the digital outputs are different for different drive series.
Output Frequency	Actual Drive Speed Monitors drive output frequency. Unit depends on o1-03. Unit is not affected by Speed Scale SS.
Dynamic Inputs	Contains the data to be read from the MEMOBUS/Modbus address defined in the given parameter. A value of 0 in the given parameter means it will return the default data as defined in the table above.

◆ (Vendor Specific Yaskawa Electric (YE) Assy) 12-Byte Dynamic Input - 168 (0xA8)

Input Instance	Word	Byte	Bit 7	Bit 6	Bit 5	Bit 4	Bit 3	Bit 2	Bit 1	Bit 0
168	0	0	Faulted	Alarm	Ready	Speed Agree	Fault Reset	REV Running	ZSP	Running
		1	ZSV	-	Multi-Function Digital Output 3	Multi-Function Digital Output 2	Multi-Function Digital Output 1	LOCAL/REMOTE	Uv	oPE

Input Instance	Word	Byte	Bit 7	Bit 6	Bit 5	Bit 4	Bit 3	Bit 2	Bit 1	Bit 0
	1	2	Output Frequency (Low Byte)							
		3	Output Frequency (High Byte)							
	2	4 - 5	Dynamic Input 1 [F7-33], Default: Alarm Code							
	3	6 - 7	Dynamic Input 2 [F7-34], Default: Output Power [U1-08]							
	4	8 - 9	Dynamic Input 3 [F7-35], Default: Analog Input 2							
5	10 - 11	Dynamic Input 4 [F7-36], Default: Digital Input								

Name	Description
Running	Running 0: Stop 1: Forward or Reverse Running
ZSP	Zero Speed 0: Running 1: Stop or DC Injection Braking
REV Running	Reverse Running 0: Not Reverse Running 1: Reverse Running
Fault Reset	Fault Reset 0: - 1: Fault Reset
Speed Agree	Speed Agree 0: - 1: Speed actual at speed reference
Ready	Ready 0: Not Ready 1: Ready
Alarm	Alarm 0: No Alarm 1: Alarm
Faulted	Faulted 0: No Fault 1: Fault
oPE	oPE 0: - 1: oPExx
Uv	Undervoltage 0: - 1: Undervoltage
LOCAL/REMOTE	Run command is from network 0: Run command is not from network 1: Run command is from network
Multi-Function Digital Output 1	Terminal M1/M2 (varies by drive model) 0: M1/M2 OFF 1: M1/M2 ON This function is enabled only when H2-01 is set to F. Note: The names of the digital outputs are different for different drive series.
Multi-Function Digital Output 2	Terminal M3/M4 (varies by drive model) 0: M3/M4 OFF 1: M3/M4 ON This function is enabled only when H2-02 is set to F. Note: The names of the digital outputs are different for different drive series.
Multi-Function Digital Output 3	Terminal M5/M6 (varies by drive model) 0: M5/M6 OFF 1: M5/M6 ON This function is enabled only when H2-03 is set to F. Note: The names of the digital outputs are different for different drive series.

9 Input Assemblies (Drive Produces)

Name	Description
Output Frequency	Actual Drive Speed Monitors drive output frequency. Unit depends on o1-03. Unit is not affected by Speed Scale SS.
Dynamic Inputs	Contains the data to be read from the MEMOBUS/Modbus address defined in the given parameter. A value of 0 in the given parameter means it will return the default data as defined in the table above.

◆ (Vendor Specific Yaskawa Electric (YE) Assy) 18-Byte Dynamic Input - 169 (0xA9)

Input Instance	Word	Byte	Bit 7	Bit 6	Bit 5	Bit 4	Bit 3	Bit 2	Bit 1	Bit 0	
169	0	0	Faulted	Alarm	Ready	Speed Agree	Fault Reset	REV Running	ZSP	Running	
		1	ZSV	-	Multi-Function Digital Output 3	Multi-Function Digital Output 2	Multi-Function Digital Output 1	LOCAL/REMOTE	Uv	oPE	
	1	2	Output Frequency (Low Byte)								
		3	Output Frequency (High Byte)								
	2	4 - 5	Dynamic Input 1 [F7-33], Default: Fault Code								
	3	6 - 7	Dynamic Input 2 [F7-34], Default: Output Power [U1-08]								
	4	8 - 9	Dynamic Input 3 [F7-35], Default: Analog Input 2								
	5	10 - 11	Dynamic Input 4 [F7-36], Default: Digital Input								
	6	12 - 13	Dynamic Input 5 [F7-37], Default: Analog Input 3								
	7	14 - 15	Dynamic Input 6 [F7-38], Default: PG 2 Counter								
8	16 - 17	Dynamic Input 7 [F7-39], Default: Net Ref and Net Ctrl									

Name	Description
Running	Running 0: Stop 1: Forward or Reverse Running
ZSP	Zero Speed 0: Running 1: Stop or DC Injection Braking
REV Running	Reverse Running 0: Not Reverse Running 1: Reverse Running
Fault Reset	Fault Reset 0: - 1: Fault Reset
Speed Agree	Speed Agree 0: - 1: Speed actual at speed reference
Ready	Ready 0: Not Ready 1: Ready
Alarm	Alarm 0: No Alarm 1: Alarm
Faulted	Faulted 0: No Fault 1: Fault
oPE	oPE 0: - 1: oPExx
Uv	Undervoltage 0: - 1: Undervoltage
LOCAL/REMOTE	Run command is from network 0: Run command is not from network

Name	Description
	1: Run command is from network
Multi-Function Digital Output 1	Terminal M1/M2 (varies by drive model) 0: M1/M2 OFF 1: M1/M2 ON This function is enabled only when H2-01 is set to F. Note: The names of the digital outputs are different for different drive series.
Multi-Function Digital Output 2	Terminal M3/M4 (varies by drive model) 0: M3/M4 OFF 1: M3/M4 ON This function is enabled only when H2-02 is set to F. Note: The names of the digital outputs are different for different drive series.
Multi-Function Digital Output 3	Terminal M5/M6 (varies by drive model) 0: M5/M6 OFF 1: M5/M6 ON This function is enabled only when H2-03 is set to F. Note: The names of the digital outputs are different for different drive series.
Output Frequency	Actual Drive Speed Monitors drive output frequency. Unit depends on o1-03. Unit is not affected by Speed Scale SS.
Dynamic Inputs	Contains the data to be read from the MEMOBUS/Modbus address defined in the given parameter. A value of 0 in the given parameter means it will return the default data as defined in the table above.

◆ (Vendor Specific Yaskawa Electric (YE) Assy) 24-Byte Dynamic Input - 170 (0xAA)

Input Instance	Word	Byte	Bit 7	Bit 6	Bit 5	Bit 4	Bit 3	Bit 2	Bit 1	Bit 0	
170	0	0	Faulted	Alarm	Ready	Speed Agree	Fault Reset	REV Running	ZSP	Running	
		1	ZSV	-	Multi-Function Digital Output 3	Multi-Function Digital Output 2	Multi-Function Digital Output 1	LOCAL/REMOTE	Uv	oPE	
	1	2	Output Frequency (Low Byte)								
		3	Output Frequency (High Byte)								
	2	4 - 5	Dynamic Input 1 [F7-33], Default: Fault Code								
	3	6 - 7	Dynamic Input 2 [F7-34], Default: Output Power [U1-08]								
	4	8 - 9	Dynamic Input 3 [F7-35], Default: Analog Input 2								
	5	10 - 11	Dynamic Input 4 [F7-36], Default: Digital Input								
	6	12 - 13	Dynamic Input 5 [F7-37], Default: Analog Input 3								
	7	14 - 15	Dynamic Input 6 [F7-38], Default: PG 2 Counter								
	8	16 - 17	Dynamic Input 7 [F7-39], Default: Net Ref and Net Ctrl								
	9	18 - 19	Dynamic Input 8 [F7-40], Default: Drive Software Version								
10	20 - 21	Dynamic Input 9 [F7-41], Default: Not Used									
11	22 - 23	Dynamic Input 10 [F7-42], Default: Not Used									

Name	Description
Running	Running 0: Stop 1: Forward or Reverse Running
ZSP	Zero Speed 0: Running 1: Stop or DC Injection Braking
REV Running	Reverse Running 0: Not Reverse Running 1: Reverse Running
Fault Reset	Fault Reset

9 Input Assemblies (Drive Produces)

Name	Description
	0: - 1: Fault Reset
Speed Agree	Speed Agree 0: - 1: Speed actual at speed reference
Ready	Ready 0: Not Ready 1: Ready
Alarm	Alarm 0: No Alarm 1: Alarm
Faulted	Faulted 0: No Fault 1: Fault
oPE	oPE 0: - 1: oPExx
Uv	Undervoltage 0: - 1: Undervoltage
LOCAL/REMOTE	Run command is from network 0: Run command is not from network 1: Run command is from network
Multi-Function Digital Output 1	Terminal M1/M2 (varies by drive model) 0: M1/M2 OFF 1: M1/M2 ON This function is enabled only when H2-01 is set to F. Note: The names of the digital outputs are different for different drive series.
Multi-Function Digital Output 2	Terminal M3/M4 (varies by drive model) 0: M3/M4 OFF 1: M3/M4 ON This function is enabled only when H2-02 is set to F. Note: The names of the digital outputs are different for different drive series.
Multi-Function Digital Output 3	Terminal M5/M6 (varies by drive model) 0: M5/M6 OFF 1: M5/M6 ON This function is enabled only when H2-03 is set to F. Note: The names of the digital outputs are different for different drive series.
Output Frequency	Actual Drive Speed Monitors drive output frequency. Unit depends on o1-03. Unit is not affected by Speed Scale SS.
Dynamic Inputs	Contains the data to be read from the MEMOBUS/Modbus address defined in the given parameter. A value of 0 in the given parameter means it will return the default data as defined in the table above.

◆ (Vendor Specific Yaskawa Electric (YE) Assy) Gateway Produce Assembly - 180 (0xB4)

Note:

This assembly will not work on drives or bypass units that do not support the gateway functionality. Refer to the instruction manual of your specific drive for more information.

The drive reads the values of parameters *F7-33 to F7-42 [Dynamic In Param 1 to 10 for CommCard]* on power-up or after a reset. You must cycle power on the drive or reset the software on the option to change these parameter values.

The option reads registers 15E7 (Hex.) through 15EE (Hex.) every 500 ms.

The option reads registers 15EF (Hex.) through 15F1 (Hex.) every 2 seconds.

Input Instance	Word	Byte	Modbus Address (Hex.)	Bit 10	Bit 9	Bit 8	Bit 7	Bit 6	Bit 5	Bit 4	Bit 3	Bit 2	Bit 1	Bit 0	
180	0	0 - 1	004B	Drive (Master) Status											
	1	2 - 3	0041	Drive (Master) Output Frequency											
	2	4 - 5	15E7	Slave Drive 1 Status											
	3	6 - 7	15E8	Slave Drive 1 Output Frequency											
	4	8 - 9	15E9	Slave Drive 2 Status											
	5	10 - 11	15EA	Slave Drive 2 Output Frequency											
	6	12 - 13	15EB	Slave Drive 3 Status											
	7	14 - 15	15EC	Slave Drive 3 Output Frequency											
	8	16 - 17	15ED	Slave Drive 4 Status											
	9	18 - 19	15EE	Slave Drive 4 Output Frequency											
	10	20 - 21	15EF	Communication Status											
					Drive Number				Command Status						
	11	22 - 23	15F0	Target Register Address											
	12	24 - 25	15F1	Read or Write Data											
	13	26 - 27	Configurable (F7-33)	Dynamic Input 1											
	14	28 - 29	Configurable (F7-34)	Dynamic Input 2											
	15	30 - 31	Configurable (F7-35)	Dynamic Input 3											
	16	32 - 33	Configurable (F7-36)	Dynamic Input 4											
	17	34 - 35	Configurable (F7-37)	Dynamic Input 5											
	18	36 - 37	Configurable (F7-38)	Dynamic Input 6											
	19	38 - 39	Configurable (F7-39)	Dynamic Input 7											
	20	40 - 41	Configurable (F7-40)	Dynamic Input 8											
	21	42 - 43	Configurable (F7-41)	Dynamic Input 9											
22	44 - 45	Configurable (F7-42)	Dynamic Input 10												
23	46 - 47	Reserved	Reserved												

Name	Description
Output Frequency	Actual Drive Speed Monitors drive output frequency. Unit depends on o1-03. Unit is not affected by Speed Scale SS.
Dynamic Inputs	Contains the data to be read from the MEMOBUS/Modbus address defined in the given parameter. A value of 0 in the given parameter means it will return the default data as defined in the table above.

10 Output Assemblies (Converter Consumes)

Note:

The convention in this manual is from the PLC perspective. As such, an assembly is called an "Output Assembly" when outputted from the PLC and received by this node. This section details "Output Assemblies" that are "Consumed" by the converter.

◆ EtherNet/IP Basic Speed Control Output - 20 (0x14)

Output Instance	Word	Byte	Bit 7	Bit 6	Bit 5	Bit 4	Bit 3	Bit 2	Bit 1	Bit 0	
20	0	0	-	-	-	-	-	Fault Reset	-	D1000: Run R1000: Auto Run	
		1	-								
	1	2	D1000: Voltage Reference (Low Byte) R1000: -								
		3	D1000: Voltage Reference (High Byte) R1000: -								

Name	Description
D1000: Run R1000: Auto Run	D1000: Run converter 0: Stop 1: Run R1000: Run converter in auto 0: Stop 1: Auto Run
Fault Reset	Fault Reset 0: - 1: Fault Reset
D1000: Voltage Reference (High Byte) R1000: -	D1000: Voltage Reference Sets converter voltage reference. Voltage reference data: Voltage reference/2VS (VS: Voltage scale) Setting range: 0 - FFFF (Hex.) Example: setting a reference of 4096 with a voltage scale of 2: Voltage reference data = 4096/2 ² = 1024 = 400 (Hex.) Unit depends on <i>o1-03</i> . R1000: -

◆ EtherNet/IP Extended Speed Control Output - 21 (0x15)

Output Instance	Word	Byte	Bit 7	Bit 6	Bit 5	Bit 4	Bit 3	Bit 2	Bit 1	Bit 0	
21	0	0	-	D1000: NetRef R1000: -	NetCtrl	-	-	Fault Reset	D1000: - R1000: Forced Run	D1000: Run R1000: Auto Run	
		1	-								
	1	2	D1000: Voltage Reference (Low Byte) R1000: -								
		3	D1000: Voltage Reference (High Byte) R1000: -								

Name	Description
D1000: Run R1000: Auto Run	D1000: Run converter 0: Stop 1: Run R1000: Run converter in auto 0: Stop 1: Auto Run
D1000: - R1000: Forced Run	D1000: - R1000: Force run converter 0: Stop 1: Force Run
Fault Reset	Fault Reset 0: - 1: Fault Reset
NetCtrl	Run command from network 0: Depends on <i>b1-02</i> 1: Run Command is from network

Name	Description
D1000: NetRef R1000: -	D1000: Voltage command from network 0: Depends on <i>b1-01</i> 1: Voltage command from network R1000: -
D1000: Voltage Reference R1000: -	D1000: Voltage Reference Sets converter voltage reference. Voltage reference data: Voltage reference/2VS (VS: Voltage scale) Setting range: 0 - FFFF (Hex.) Example: setting a reference of 4096 with a voltage scale of 2: Voltage reference data = $4096/2^2 = 1024 = 400$ (Hex.) Unit depends on <i>o1-03</i> . R1000: -

◆ EtherNet/IP Speed and Torque Control Output - 22 (0x16)

Output Instance	Word	Byte	Bit 7	Bit 6	Bit 5	Bit 4	Bit 3	Bit 2	Bit 1	Bit 0	
22	0	0	-	-	-	-	-	Fault Reset	-	D1000: Run R1000: Auto Run	
		1	-								
	1	2	D1000: Voltage Reference (Low Byte) R1000: -								
		3	D1000: Voltage Reference (High Byte) R1000: -								

Name	Description
D1000: Run R1000: Auto Run	D1000: Run converter 0: Stop 1: Run R1000: Run converter in auto 0: Stop 1: Auto Run
Fault Reset	Fault Reset 0: - 1: Fault Reset
D1000: Voltage Reference R1000: -	D1000: Voltage Reference Sets converter voltage reference. Voltage reference data: Voltage reference/2VS (VS: Voltage scale) Setting range: 0 - FFFF (Hex.) Example: setting a reference of 4096 with a voltage scale of 2: Voltage reference data = $4096/2^2 = 1024 = 400$ (Hex.) Unit depends on <i>o1-03</i> . R1000: -

◆ EtherNet/IP Extended Speed and Torque Control Output - 23 (0x17)

Output Instance	Word	Byte	Bit 7	Bit 6	Bit 5	Bit 4	Bit 3	Bit 2	Bit 1	Bit 0	
23	0	0	-	D1000: NetRef R1000: -	NetCtrl	-	-	Fault Reset	D1000: - R1000: Forced Run	D1000: Run R1000: Auto Run	
		1	-								
	1	2	D1000: Voltage Reference (Low Byte) R1000: -								
		3	D1000: Voltage Reference (High Byte) R1000: -								

10 Output Assemblies (Converter Consumes)

Name	Description
D1000: Run R1000: Auto Run	D1000: Run converter 0: Stop 1: Run R1000: Run converter in auto 0: Stop 1: Auto Run
D1000: - R1000: Forced Run	D1000: - R1000: Force run converter
Fault Reset	Fault Reset 0: - 1: Fault Reset
NetCtrl	Run command from network 0: Depends on <i>b1-02</i> 1: Enables the run command from network
D1000: NetRef R1000: -	D1000: Voltage command from network 0: Depends on <i>b1-01</i> 1: Voltage command from network R1000: -
D1000: Voltage Reference R1000: -	D1000: Voltage Reference Sets converter voltage reference. Voltage reference data: Voltage reference/2VS (VS: Voltage scale) Setting range: 0 - FFFF (Hex.) Example: setting a reference of 4096 with a voltage scale of 2: Voltage reference data = $4096/2^2 = 1024 = 400$ (Hex.) Unit depends on <i>o1-03</i> . R1000: -

◆ (Vendor Specific Yaskawa Electric (YE) Assy) Speed/Torque Control Output - 101 (0x65)

Output Instance	Word	Byte	Bit 7	Bit 6	Bit 5	Bit 4	Bit 3	Bit 2	Bit 1	Bit 0	
101	0	0	Multi-Function Input 8	Multi-Function Input 7	Multi-Function Input 6	Multi-Function Input 5	Multi-Function Input 4	Multi-Function Input 3	D1000: - R1000: Forced Run	D1000: Run R1000: Auto Run	
		1	Multi-Function Digital Output 3	Multi-Function Digital Output 2	Multi-Function Digital Output 1	-	-	-	Fault Reset	External Fault	
	1	2	D1000: Voltage Reference (Low Byte) R1000: -								
		3	D1000: Voltage Reference (High Byte) R1000: -								

Name	Description
D1000: Run R1000: Auto Run	D1000: Run converter 0: Stop 1: Run R1000: Run converter in auto 0: Stop 1: Auto Run
D1000: - R1000: Forced Run	D1000: - R1000: Force run converter 0: Stop 1: Force Run
Multi-Function Input 3	Terminal S3 Function Input 0: Terminal S3 Function [H1-03] OFF 1: Terminal S3 Function [H1-03] ON
Multi-Function Input 4	Terminal S4 Function Input 0: Terminal S4 Function [H1-04] OFF 1: Terminal S4 Function [H1-04] ON
Multi-Function Input 5	Terminal S5 Function Input 0: Terminal S5 Function [H1-05] OFF 1: Terminal S5 Function [H1-05] ON
Multi-Function Input 6	Terminal S6 Function Input

	0: Terminal S6 Function [H1-06] OFF 1: Terminal S6 Function [H1-06] ON
Multi-Function Input 7	Terminal S7 Function Input 0: Terminal S7 Function [H1-07] OFF 1: Terminal S7 Function [H1-07] ON
Multi-Function Input 8	Terminal S8 Function Input 0: Terminal S8 Function [H1-08] OFF 1: Terminal S8 Function [H1-08] ON
External Fault	External Fault EF0 0: - 1: External Fault [EF0]
Fault Reset	Fault Reset 0: - 1: Fault Reset
Multi-Function Digital Output 1	Terminal M1/M2 (varies by converter model) 0: M1/M2 OFF 1: M1/M2 ON This function is enabled only when H2-01 is set to F. Note: The names of the digital outputs are different for different converter series.
Multi-Function Digital Output 2	Terminals M3 and M4 0: M3/M4 OFF 1: M3/M4 ON This function is enabled only when H2-02 is set to F. Note: The names of the digital outputs are different for different converter series.
Multi-Function Digital Output 3	Terminals M5 and M6 0: M5/M6 OFF 1: M5/M6 ON This function is enabled only when H2-03 is set to F. Note: The names of the digital outputs are different for different converter series.
D1000: Voltage Reference R1000: -	D1000: Voltage Reference Sets converter voltage reference. R1000: -

◆ (Vendor Specific Yaskawa Electric (YE) Assy) Extended Speed/Torque Control Output - 115 (0x73)

Output Instance	Word	Byte	Bit 7	Bit 6	Bit 5	Bit 4	Bit 3	Bit 2	Bit 1	Bit 0	
115	0	0	Multi-Function Input 8	Multi-Function Input 7	Multi-Function Input 6	Multi-Function Input 5	Multi-Function Input 4	Multi-Function Input 3	D1000: - R1000: Forced Run	D1000: Run R1000: Auto Run	
		1	Multi-Function Digital Output 3	Multi-Function Digital Output 2	Multi-Function Digital Output 1	-	-	-	Fault Reset	External Fault	
	1	2	D1000: Voltage Reference (Low Byte) R1000: -								
		3	D1000: Voltage Reference (High Byte) R1000: -								
	2	4	-								
		5	-								
	3	6	-								
		7	-								
	4 - 5	8 - 11	Reserved								
	6	12	Analog Output 1 (Low Byte)								
		13	Analog Output 1 (High Byte)								
	7	14	Analog Output 2 (Low Byte)								
		15	Analog Output 2 (High Byte)								
	8	16	Digital Outputs (Low Byte)								

10 Output Assemblies (Converter Consumes)

Output Instance	Word	Byte	Bit 7	Bit 6	Bit 5	Bit 4	Bit 3	Bit 2	Bit 1	Bit 0
		17	Digital Outputs (High Byte)							
	9 - 19	18 - 39	Reserved							

Name	Description
D1000: Run R1000: Auto Run	D1000: Run converter 0: Stop 1: Run R1000: Run converter in auto 0: Stop 1: Auto Run
D1000: - R1000: Forced Run	D1000: - R1000: Force run converter 0: Stop 1: Force Run
Multi-Function Input 3	Terminal S3 Function Input 0: Terminal S3 Function [H1-03] OFF 1: Terminal S3 Function [H1-03] ON
Multi-Function Input 4	Terminal S4 Function Input 0: Terminal S4 Function [H1-04] OFF 1: Terminal S4 Function [H1-04] ON
Multi-Function Input 5	Terminal S5 Function Input 0: Terminal S5 Function [H1-05] OFF 1: Terminal S5 Function [H1-05] ON
Multi-Function Input 6	Terminal S6 Function Input 0: Terminal S6 Function [H1-06] OFF 1: Terminal S6 Function [H1-06] ON
Multi-Function Input 7	Terminal S7 Function Input 0: Terminal S7 Function [H1-07] OFF 1: Terminal S7 Function [H1-07] ON
Multi-Function Input 8	Terminal S8 Function Input 0: Terminal S8 Function [H1-08] OFF 1: Terminal S8 Function [H1-08] ON
External Fault	External Fault EF0 0: - 1: External Fault [EF0]
Fault Reset	Fault Reset 0: - 1: Fault Reset
Multi-Function Digital Output 1	Terminal M1/M2 (varies by converter model) 0: M1/M2 OFF 1: M1/M2 ON This function is enabled only when H2-01 is set to F. Note: The names of the digital outputs are different for different converter series.
Multi-Function Digital Output 2	Terminal M3/M4 (varies by converter model) 0: M3/M4 OFF 1: M3/M4 ON This function is enabled only when H2-02 is set to F. Note: The names of the digital outputs are different for different converter series.
Multi-Function Digital Output 3	Terminal M5/M6 (varies by converter model) 0: M5/M6 OFF 1: M5/M6 ON This function is enabled only when H2-03 is set to F. Note: The names of the digital outputs are different for different converter series.
D1000: Voltage Reference R1000: -	D1000: Voltage Reference Sets converter voltage reference. R1000: -
Analog Output 1	MEMOBUS/Modbus (0x0007)

Name	Description
Analog Output 2	MEMOBUS/Modbus (0x0008)
Digital Outputs	MEMOBUS/Modbus (0x0009) Note: Note: These values are ORed with values in byte 1.

◆ (Vendor Specific Yaskawa Electric (YE) Assy)-High Speed/Torque Control Output - 116 (0x74)

The first 20 Bytes (0-19) are fixed and the next 20 Bytes can be configured using parameters F7-23 to F7-32. If an error occurs while trying to write to the dynamic parameters, the appropriate error bit in Assembly 166 will be set. If more information is needed as to the nature of the error, the extended error status can be read explicitly through Class 4, Instance 0xA6, Attribute 0x64. This will return 20 Bytes with each dynamic parameter in Assembly 116 having a Byte dedicated to its extended error status.

Output Instance	Word	Byte	Bit 7	Bit 6	Bit 5	Bit 4	Bit 3	Bit 2	Bit 1	Bit 0	
116	0	0	Multi-Function Input 8	Multi-Function Input 7	Multi-Function Input 6	Multi-Function Input 5	Multi-Function Input 4	Multi-Function Input 3	D1000: - R1000: Forced Run	D1000: Run R1000: Auto Run	
		1	Multi-Function Digital Output 3	Multi-Function Digital Output 2	Multi-Function Digital Output 1	-	-	-	Fault Reset	External Fault	
	1	2	D1000: Voltage Reference (Low Byte) R1000: -								
		3	D1000: Voltage Reference (High Byte) R1000: -								
	2	4	-								
		5	-								
	3	6	-								
		7	-								
	4	8	Reserved								
		9	-	-	-	-	Multi-Function Input 12	Multi-Function Input 11	Multi-Function Input 10	Multi-Function Input 9	
	5	10	-	-	-	-	-	-	NetCtrl	D1000: NetRef R1000: -	
		11	Reserved								
	6	12	Analog Output 1 (Low Byte)								
		13	Analog Output 1 (High Byte)								
	7	14	Analog Output 2 (Low Byte)								
		15	Analog Output 2 (High Byte)								
	8	16	Digital Outputs (Low Byte)								
		17	Digital Outputs (High Byte)								
	9	18	Reserved								
		19	Reserved								
	10	20 - 21	Programmable Bytes [F7-23], Default: Not Used								
	11	22 - 23	Programmable Bytes [F7-24], Default: Not Used								
	12	24 - 25	Programmable Bytes [F7-25], Default: Not Used								
	13	26 - 27	Programmable Bytes [F7-26], Default: Not Used								
	14	28 - 29	Programmable Bytes [F7-27], Default: Not Used								
	15	30 - 31	Programmable Bytes [F7-28], Default: Not Used								
	16	32 - 33	Programmable Bytes [F7-29], Default: Not Used								
	17	34 - 35	Programmable Bytes [F7-30], Default: Not Used								
	18	36 - 37	Programmable Bytes [F7-31], Default: Not Used								

10 Output Assemblies (Converter Consumes)

Output Instance	Word	Byte	Bit 7	Bit 6	Bit 5	Bit 4	Bit 3	Bit 2	Bit 1	Bit 0
	19	38 - 39	Programmable Bytes [F7-32], Default: Not Used							
	20 - 21	40 - 43	Reserved							

Name	Description
D1000: Run R1000: Auto Run	D1000: Run converter 0: Stop 1: Run R1000: Run converter in auto 0: Stop 1: Auto Run
D1000: - R1000: Forced Run	D1000: - R1000: Force run converter 0: Stop 1: Force Run
Multi-Function Input 3	Terminal S3 Function Input 0: Terminal S3 Function [H1-03] OFF 1: Terminal S3 Function [H1-03] ON
Multi-Function Input 4	Terminal S4 Function Input 0: Terminal S4 Function [H1-04] OFF 1: Terminal S4 Function [H1-04] ON
Multi-Function Input 5	Terminal S5 Function Input 0: Terminal S5 Function [H1-05] OFF 1: Terminal S5 Function [H1-05] ON
Multi-Function Input 6	Terminal S6 Function Input 0: Terminal S6 Function [H1-06] OFF 1: Terminal S6 Function [H1-06] ON
Multi-Function Input 7	Terminal S7 Function Input 0: Terminal S7 Function [H1-07] OFF 1: Terminal S7 Function [H1-07] ON
Multi-Function Input 8	Terminal S8 Function Input 0: Terminal S8 Function [H1-08] OFF 1: Terminal S8 Function [H1-08] ON
External Fault	External Fault EF0 0: - 1: External Fault [EF0]
Fault Reset	Fault Reset 0: - 1: Fault Reset
Multi-Function Digital Output 1	Terminal M1/M2 (varies by converter model) 0: M1/M2 OFF 1: M1/M2 ON This function is enabled only when H2-01 is set to F. Note: The names of the digital outputs are different for different converter series.
Multi-Function Digital Output 2	Terminal M3/M4 (varies by converter model) 0: M3/M4 OFF 1: M3/M4 ON This function is enabled only when H2-02 is set to F. Note: The names of the digital outputs are different for different converter series.
Multi-Function Digital Output 3	Terminal M5/M6 (varies by converter model) 0: M5/M6 OFF 1: M5/M6 ON This function is enabled only when H2-03 is set to F. Note: The names of the digital outputs are different for different converter series.
D1000: Voltage Reference R1000: -	D1000: Voltage Reference Sets converter voltage reference. R1000: -
Digital Inputs	Sets digital inputs 9-12 if the drive supports them.
D1000: NetRef R1000: -	D1000: Voltage command from network R1000: -
NetCtrl	Run command from network

Name	Description
Analog Output 1	MEMOBUS/Modbus (0x0007)
Analog Output 2	MEMOBUS/Modbus (0x0008)
Digital Outputs	MEMOBUS/Modbus (0x0009) Note: These values are ORed with values in byte 1.
Programmable Bytes	Contains the data to be written to the MEMOBUS/Modbus address defined in the given parameter. A value of 0 in the given parameter means it is not used, therefore the value received for this given parameter will not be written to any MEMOBUS/Modbus register.

◆ (Vendor Specific Yaskawa Electric (YE) Assy) 8 Byte Dynamic 2 Output - 117 (0x75)

Output Instance	Word	Byte	Bit 7	Bit 6	Bit 5	Bit 4	Bit 3	Bit 2	Bit 1	Bit 0	
117	0	0	Multi-Function Input 8	Multi-Function Input 7	Multi-Function Input 6	Multi-Function Input 5	Multi-Function Input 4	Multi-Function Input 3	D1000: - R1000: Forced Run	D1000: Run R1000: Auto Run	
		1	Multi-Function Digital Output 3	Multi-Function Digital Output 2	Multi-Function Digital Output 1	-	-	-	Fault Reset	External Fault	
	1	2	D1000: Voltage Reference (Low Byte) R1000: -								
		3	D1000: Voltage Reference (High Byte) R1000: -								
	2	4-5	Programmable Bytes [F7-23], Default: Not Used								
	3	6-7	Programmable Bytes [F7-24], Default: Not Used								

Name	Description
D1000: Run R1000: Auto Run	D1000: Run converter 0: Stop 1: Run R1000: Run converter in auto 0: Stop 1: Auto Run
D1000: - R1000: Forced Run	D1000: - R1000: Force run converter 0: Stop 1: Force Run
Multi-Function Input 3	Terminal S3 Function Input 0: Terminal S3 Function [H1-03] OFF 1: Terminal S3 Function [H1-03] ON
Multi-Function Input 4	Terminal S4 Function Input 0: Terminal S4 Function [H1-04] OFF 1: Terminal S4 Function [H1-04] ON
Multi-Function Input 5	Terminal S5 Function Input 0: Terminal S5 Function [H1-05] OFF 1: Terminal S5 Function [H1-05] ON
Multi-Function Input 6	Terminal S6 Function Input 0: Terminal S6 Function [H1-06] OFF 1: Terminal S6 Function [H1-06] ON
Multi-Function Input 7	Terminal S7 Function Input 0: Terminal S7 Function [H1-07] OFF 1: Terminal S7 Function [H1-07] ON
Multi-Function Input 8	Terminal S8 Function Input 0: Terminal S8 Function [H1-08] OFF 1: Terminal S8 Function [H1-08] ON
External Fault	External Fault EF0 0: - 1: External Fault [EF0]
Fault Reset	Fault Reset 0: - 1: Fault Reset

10 Output Assemblies (Converter Consumes)

Name	Description
Multi-Function Digital Output 1	Terminal M1/M2 (varies by converter model) 0: M1/M2 OFF 1: M1/M2 ON This function is enabled only when H2-01 is set to F. Note: The names of the digital outputs are different for different converter series.
Multi-Function Digital Output 2	Terminal M3/M4 (varies by converter model) 0: M3/M4 OFF 1: M3/M4 ON This function is enabled only when H2-02 is set to F. Note: The names of the digital outputs are different for different converter series.
Multi-Function Digital Output 3	Terminal M5/M6 (varies by converter model) 0: M5/M6 OFF 1: M5/M6 ON This function is enabled only when H2-03 is set to F. Note: The names of the digital outputs are different for different converter series.
D1000: Voltage Reference R1000: -	D1000: Voltage Reference Sets converter voltage reference. R1000: -
Programmable Bytes	Contains the data to be written to the MEMOBUS/Modbus address defined in the given parameter. A value of 0 in the given parameter means it is not used, therefore the value received for this given parameter will not be written to any MEMOBUS/Modbus register.

◆ (Vendor Specific Yaskawa Electric (YE) Assy) 12 Byte Dynamic 4 Output - 118 (0x76)

Output Instance	Word	Byte	Bit 7	Bit 6	Bit 5	Bit 4	Bit 3	Bit 2	Bit 1	Bit 0	
118	0	0	Multi-Function Input 8	Multi-Function Input 7	Multi-Function Input 6	Multi-Function Input 5	Multi-Function Input 4	Multi-Function Input 3	D1000: - R1000: Forced Run	D1000: Run R1000: Auto Run	
		1	Multi-Function Digital Output 3	Multi-Function Digital Output 2	Multi-Function Digital Output 1	-	-	-	Fault Reset	External Fault	
	1	2	D1000: Voltage Reference (Low Byte) R1000: -								
		3	D1000: Voltage Reference (High Byte) R1000: -								
	2	4-5	Programmable Bytes [F7-23], Default: Not Used								
	3	6-7	Programmable Bytes [F7-24], Default: Not Used								
	4	8-9	Programmable Bytes [F7-25], Default: Not Used								
	5	10-11	Programmable Bytes [F7-26], Default: Not Used								

Name	Description
D1000: Run R1000: Auto Run	D1000: Run converter 0: Stop 1: Run R1000: Run converter in auto 0: Stop 1: Auto Run
D1000: - R1000: Forced Run	D1000: - R1000: Force run converter 0: Stop 1: Force Run
Multi-Function Input 3	Terminal S3 Function Input 0: Terminal S3 Function [H1-03] OFF 1: Terminal S3 Function [H1-03] ON
Multi-Function Input 4	Terminal S4 Function Input 0: Terminal S4 Function [H1-04] OFF 1: Terminal S4 Function [H1-04] ON
Multi-Function Input 5	Terminal S5 Function Input

Name	Description
	0: Terminal S5 Function [H1-05] OFF 1: Terminal S5 Function [H1-05] ON
Multi-Function Input 6	Terminal S6 Function Input 0: Terminal S6 Function [H1-06] OFF 1: Terminal S6 Function [H1-06] ON
Multi-Function Input 7	Terminal S7 Function Input 0: Terminal S7 Function [H1-07] OFF 1: Terminal S7 Function [H1-07] ON
Multi-Function Input 8	Terminal S8 Function Input 0: Terminal S8 Function [H1-08] OFF 1: Terminal S8 Function [H1-08] ON
External Fault	External Fault EF0 0: - 1: External Fault [EF0]
Fault Reset	Fault Reset 0: - 1: Fault Reset
Multi-Function Digital Output 1	Terminal M1/M2 (varies by converter model) 0: M1/M2 OFF 1: M1/M2 ON This function is enabled only when H2-01 is set to F.
Multi-Function Digital Output 2	Terminals M3 and M4 0: M3/M4 OFF 1: M3/M4 ON This function is enabled only when H2-02 is set to F.
Multi-Function Digital Output 3	Terminals M5 and M6 0: M5/M6 OFF 1: M5/M6 ON This function is enabled only when H2-03 is set to F.
D1000: Voltage Reference R1000: -	D1000: Voltage Reference Sets converter voltage reference. R1000: -
Programmable Bytes	Contains the data to be written to the MEMOBUS/Modbus address defined in the given parameter. A value of 0 in the given parameter means it is not used, therefore the value received for this given parameter will not be written to any MEMOBUS/Modbus register.

◆ (Vendor Specific Yaskawa Electric (YE) Assy) 18 Byte Dynamic 7 Output - 119 (0x77)

Output Instance	Word	Byte	Bit 7	Bit 6	Bit 5	Bit 4	Bit 3	Bit 2	Bit 1	Bit 0	
119	0	0	Multi-Function Input 8	Multi-Function Input 7	Multi-Function Input 6	Multi-Function Input 5	Multi-Function Input 4	Multi-Function Input 3	D1000: - R1000: Forced Run	D1000: Run R1000: Auto Run	
		1	Multi-Function Digital Output 3	Multi-Function Digital Output 2	Multi-Function Digital Output 1	-	-	-	Fault Reset	External Fault	
	1	2	D1000: Voltage Reference (Low Byte) R1000: -								
		3	D1000: Voltage Reference (High Byte) R1000: -								
	2	4-5	Programmable Bytes [F7-23], Default: Not Used								
	3	6-7	Programmable Bytes [F7-24], Default: Not Used								
	4	8-9	Programmable Bytes [F7-25], Default: Not Used								
	5	10-11	Programmable Bytes [F7-26], Default: Not Used								
	6	12-13	Programmable Bytes [F7-27], Default: Not Used								
	7	14-15	Programmable Bytes [F7-28], Default: Not Used								
8	16-17	Programmable Bytes [F7-29], Default: Not Used									

10 Output Assemblies (Converter Consumes)

Name	Description
D1000: Run R1000: Auto Run	D1000: Run converter 0: Stop 1: Run R1000: Run converter in auto 0: Stop 1: Auto Run
D1000: - R1000: Forced Run	D1000: - R1000: Force run converter 0: Stop 1: Force Run
Multi-Function Input 3	Terminal S3 Function Input 0: Terminal S3 Function [H1-03] OFF 1: Terminal S3 Function [H1-03] ON
Multi-Function Input 4	Terminal S4 Function Input 0: Terminal S4 Function [H1-04] OFF 1: Terminal S4 Function [H1-04] ON
Multi-Function Input 5	Terminal S5 Function Input 0: Terminal S5 Function [H1-05] OFF 1: Terminal S5 Function [H1-05] ON
Multi-Function Input 6	Terminal S6 Function Input 0: Terminal S6 Function [H1-06] OFF 1: Terminal S6 Function [H1-06] ON
Multi-Function Input 7	Terminal S7 Function Input 0: Terminal S7 Function [H1-07] OFF 1: Terminal S7 Function [H1-07] ON
Multi-Function Input 8	Terminal S8 Function Input 0: Terminal S8 Function [H1-08] OFF 1: Terminal S8 Function [H1-08] ON
External Fault	External Fault EF0 0: - 1: External Fault [EF0]
Fault Reset	Fault Reset 0: - 1: Fault Reset
Multi-Function Digital Output 1	Terminal M1/M2 (varies by converter model) 0: M1/M2 OFF 1: M1/M2 ON This function is enabled only when H2-01 is set to F. Note: The names of the digital outputs are different for different converter series.
Multi-Function Digital Output 2	Terminal M3/M4 (varies by converter model) 0: M3/M4 OFF 1: M3/M4 ON This function is enabled only when H2-02 is set to F. Note: The names of the digital outputs are different for different converter series.
Multi-Function Digital Output 3	Terminal M5/M6 (varies by converter model) 0: M5/M6 OFF 1: M5/M6 ON This function is enabled only when H2-03 is set to F. Note: The names of the digital outputs are different for different converter series.
D1000: Voltage Reference R1000: -	D1000: Voltage Reference Sets converter voltage reference. R1000: -
Programmable Bytes	Contains the data to be written to the MEMOBUS/Modbus address defined in the given parameter. A value of 0 in the given parameter means it is not used, therefore the value received for this given parameter will not be written to any MEMOBUS/Modbus register.

◆ (Vendor Specific Yaskawa Electric (YE) Assy) 24 Byte Dynamic 10 Output - 120 (0x78)

Output Instance	Word	Byte	Bit 7	Bit 6	Bit 5	Bit 4	Bit 3	Bit 2	Bit 1	Bit 0	
120	0	0	Multi-Function Input 8	Multi-Function Input 7	Multi-Function Input 6	Multi-Function Input 5	Multi-Function Input 4	Multi-Function Input 3	D1000: - R1000: Forced Run	D1000: Run R1000: Auto Run	
		1	Multi-Function Digital Output 3	Multi-Function Digital Output 2	Multi-Function Digital Output 1	-	-	-	Fault Reset	External Fault	
	1	2	D1000: Voltage Reference (Low Byte) R1000: -								
		3	D1000: Voltage Reference (High Byte) R1000: -								
	2	4 -5	Programmable Bytes [F7-23], Default: Not Used								
	3	6 -7	Programmable Bytes [F7-24], Default: Not Used								
	4	8 -9	Programmable Bytes [F7-25], Default: Not Used								
	5	10 -11	Programmable Bytes [F7-26], Default: Not Used								
	6	12 -13	Programmable Bytes [F7-27], Default: Not Used								
	7	14 -15	Programmable Bytes [F7-28], Default: Not Used								
	8	16 -17	Programmable Bytes [F7-29], Default: Not Used								
	9	18 -19	Programmable Bytes [F7-30], Default: Not Used								
	10	20 -21	Programmable Bytes [F7-31], Default: Not Used								
11	22 -23	Programmable Bytes [F7-32], Default: Not Used									

Name	Description
D1000: Run R1000: Auto Run	D1000: Run converter 0: Stop 1: Run R1000: Run converter in auto 0: Stop 1: Auto Run
D1000: - R1000: Forced Run	D1000: - R1000: Force run converter 0: Stop 1: Force Run
Multi-Function Input 3	Terminal S3 Function Input 0: Terminal S3 Function [H1-03] OFF 1: Terminal S3 Function [H1-03] ON
Multi-Function Input 4	Terminal S4 Function Input 0: Terminal S4 Function [H1-04] OFF 1: Terminal S4 Function [H1-04] ON
Multi-Function Input 5	Terminal S5 Function Input 0: Terminal S5 Function [H1-05] OFF 1: Terminal S5 Function [H1-05] ON
Multi-Function Input 6	Terminal S6 Function Input 0: Terminal S6 Function [H1-06] OFF 1: Terminal S6 Function [H1-06] ON
Multi-Function Input 7	Terminal S7 Function Input 0: Terminal S7 Function [H1-07] OFF 1: Terminal S7 Function [H1-07] ON
Multi-Function Input 8	Terminal S8 Function Input 0: Terminal S8 Function [H1-08] OFF 1: Terminal S8 Function [H1-08] ON
External Fault	External Fault EF0 0: - 1: External Fault [EF0]
Fault Reset	Fault Reset 0: - 1: Fault Reset

11 Input Assemblies (Converter Produces)

Name	Description
Multi-Function Digital Output 1	Terminal M1/M2 (varies by converter model) 0: M1/M2 OFF 1: M1/M2 ON This function is enabled only when H2-01 is set to F. Note: The names of the digital outputs are different for different converter series.
Multi-Function Digital Output 2	Terminal M3/M4 (varies by converter model) 0: M3/M4 OFF 1: M3/M4 ON This function is enabled only when H2-02 is set to F. Note: The names of the digital outputs are different for different converter series.
Multi-Function Digital Output 3	Terminal M5/M6 (varies by converter model) 0: M5/M6 OFF 1: M5/M6 ON This function is enabled only when H2-03 is set to F. Note: The names of the digital outputs are different for different converter series.
D1000: Voltage Reference R1000: -	D1000: Voltage Reference Sets converter voltage reference. R1000: -
Programmable Bytes	Contains the data to be written to the MEMOBUS/Modbus address defined in the given parameter. A value of 0 in the given parameter means it is not used, therefore the value received for this given parameter will not be written to any MEMOBUS/Modbus register.

11 Input Assemblies (Converter Produces)

Note:

The convention in this manual is from the PLC perspective. An "Input Assembly" is outputted from this node and read by the PLC. This section details "Input Assemblies" that are "Produced" by the converter.

◆ EtherNet/IP Basic Speed Control Input - 70 (0x46)

Input Instance	Word	Byte	Bit 7	Bit 6	Bit 5	Bit 4	Bit 3	Bit 2	Bit 1	Bit 0	
70	0	0	-	-	-	-	-	Faulted	-	Running	
		1	-								
	1	2	Voltage Actual (Low Byte)								
		3	Voltage Actual (High Byte)								

Name	Description
Running	Running
Faulted	Faulted 0: No Fault 1: Fault
Voltage Actual	Actual Converter Voltage Monitors the converter output voltage. Voltage actual data: Output Voltage x 2VS (VS: Voltage scale) Setting range: 0 - FFFF (Hex.) For example, when output voltage of 1024 with a voltage scale of 2: Voltage actual data = $1024 \times 2 = 4096 = 1000$ (Hex.)

◆ EtherNet/IP Extended Speed Control Input - 71 (0x47)

Input Instance	Word	Byte	Bit 7	Bit 6	Bit 5	Bit 4	Bit 3	Bit 2	Bit 1	Bit 0	
71	0	0	-	NetRef	NetCtrl	Ready	During Regenerative Operation	Running	Alarm	Faulted	
		1	State								
	1	2	Voltage Actual (Low Byte)								
		3	Voltage Actual (High Byte)								

Name	Description
Faulted	Faulted 0: No Fault 1: Fault
Alarm	Alarm 0: No Alarm 1: Alarm
Running	Running
During Regenerative Operation	Converter in regenerative operation
Ready	Ready 0: Not Ready 1: Ready
NetCtrl	Run command is from network 0: Run command is not from network 1: Run command is from network
NetRef	Voltage command is from network 0: Voltage command is not from network 1: Voltage command is from network
State	Contains the value from the Control Supervisor (Class 0x29) Instance 1 Attribute 6.
Voltage Actual	Actual Converter Voltage Monitors the converter output voltage. Speed actual data: Output Voltage x 2VS (VS: Voltage scale) Setting range: 0 - FFFF (Hex.) For example, when output voltage of 1024 with a voltage scale of 2: Voltage actual data = $1024 \times 2^2 = 4096 = 1000$ (Hex.)

◆ EtherNet/IP Speed and Torque Control Input - 72 (0x48)

Input Instance	Word	Byte	Bit 7	Bit 6	Bit 5	Bit 4	Bit 3	Bit 2	Bit 1	Bit 0	
72	0	0	-	-	-	-	-	Faulted	-	Running	
		1	-								
	1	2	Voltage Actual (Low Byte)								
		3	Voltage Actual (High Byte)								

Name	Description
Running	Running
Faulted	Faulted 0: No Fault 1: Fault
Voltage Actual	Actual Converter Voltage Monitors the converter output voltage. Voltage actual data: Output Voltage x 2VS (VS: Voltage scale) Setting range: 0 - FFFF (Hex.) For example, when output voltage of 1024 with a voltage scale of 2: Voltage actual data = $1024 \times 2^2 = 4096 = 1000$ (Hex.)

◆ EtherNet/IP Extended Speed and Torque Control Input - 73 (0x49)

Input Instance	Word	Byte	Bit 7	Bit 6	Bit 5	Bit 4	Bit 3	Bit 2	Bit 1	Bit 0	
73	0	0	-	NetRef	NetCtrl	Ready	During Regenerative Operation	Running	Alarm	Faulted	
		1	State								
	1	2	Voltage Actual (Low Byte)								
		3	Voltage Actual (High Byte)								

11 Input Assemblies (Converter Produces)

Name	Description
Faulted	Faulted 0: No Fault 1: Fault
Alarm	Alarm 0: No Alarm 1: Alarm
Running	Running
During Regenerative Operation	During Regenerative Operation
Ready	Ready 0: Not Ready 1: Ready
NetCtrl	Run command is from network 0: Run command is not from network 1: Run command is from network
NetRef	Voltage command is from network 0: Voltage command is not from network 1: Voltage command is from network
State	Contains the value from the Control Supervisor (Class 0x29) Instance 1 Attribute 6.
Voltage Actual	Actual Converter Voltage Monitors the converter output voltage. Speed actual data: Output Voltage x 2VS (VS: Voltage scale) Setting range: 0 - FFFF (Hex.) For example, when output voltage of 1024 with a voltage scale of 2: Voltage actual data = $1024 \times 2^2 = 4096 = 1000$ (Hex.)

◆ (Vendor Specific Yaskawa Electric (YE) Assy) Speed/Torque Status Input - 151 (0x97)

Input Instance	Word	Byte	Bit 7	Bit 6	Bit 5	Bit 4	Bit 3	Bit 2	Bit 1	Bit 0	
151	0	0	Faulted	Alarm	Ready	During Run - Operation Ready	Reset	During Regenerative Operation	-	Running	
		1	-	-	Multi-Function Digital Output 3	Multi-Function Digital Output 2	Multi-Function Digital Output 1	LOCAL/REMOTE	Uv	oPE	
	1	2	Output Voltage (Low Byte)								
		3	Output Voltage (High Byte)								
	2	4	-								
		5	-								
	3	6	D1000: Current Actual (Low Byte) R1000: -								
		7	D1000: Current Actual (High Byte) R1000: -								

Name	Description
Running	Running 0: Stop 1: Running
During Regenerative Operation	During Regenerative Operation 0: Converter not in regenerative operation 1: Converter in regenerative operation
Reset	Reset 0: - 1: Reset
During Run - Operation Ready	During Run - Operation Ready 0: Not Ready 1: Ready
Ready	Ready 0: Not Ready 1: Ready

Name	Description
Alarm	Alarm 0: No Alarm 1: Alarm
Faulted	Faulted 0: No Fault 1: Fault
oPE	oPE 0: - 1: oPExx
Uv	Undervoltage 0: - 1: Undervoltage
LOCAL/REMOTE	Run command is from network 0: Run command is not from network 1: Run command is from network
Multi-Function Digital Output 1	Terminal M1/M2 (varies by converter model) 0: M1/M2 OFF 1: M1/M2 ON This function is enabled only when H2-01 is set to F. Note: The names of the digital outputs are different for different converter series.
Multi-Function Digital Output 2	Terminal M3/M4 (varies by converter model) 0: M3/M4 OFF 1: M3/M4 ON This function is enabled only when H2-02 is set to F. Note: The names of the digital outputs are different for different converter series.
Multi-Function Digital Output 3	Terminal M5/M6 (varies by converter model) 0: M5/M6 OFF 1: M5/M6 ON This function is enabled only when H2-03 is set to F. Note: The names of the digital outputs are different for different converter series.
Output Voltage	Converter Output Voltage
D1000: Current Actual R1000: -	D1000: Actual Output Current Monitors the converter output current. Unit: 0.1 A Unit is not affected by Current Scale CS. R1000: -

◆ (Vendor Specific Yaskawa Electric (YE) Assy) Extended Speed/Torque Status Input - 155 (0x9B)

Input Instance	Word	Byte	Bit 7	Bit 6	Bit 5	Bit 4	Bit 3	Bit 2	Bit 1	Bit 0	
155	0	0	Faulted	Alarm	Ready	During Run - Operation Ready	Reset	During Regenerative Operation	-	Running	
		1	-	-	Multi-Function Digital Output 3	Multi-Function Digital Output 2	Multi-Function Digital Output 1	LOCAL/REMOTE	Uv	oPE	
	1	2	Output Voltage (Low Byte)								
		3	Output Voltage (High Byte)								
	2	4	-								
		5	-								
	3	6	-								
		7	-								
	4	8	D1000: Voltage Command (Low Byte) R1000: -								
		9	D1000: Voltage Command (High Byte) R1000: -								
	5	10	Output Voltage (Low Byte)								

11 Input Assemblies (Converter Produces)

Input Instance	Word	Byte	Bit 7	Bit 6	Bit 5	Bit 4	Bit 3	Bit 2	Bit 1	Bit 0
		11	Output Voltage (High Byte)							
6		12	D1000: Output Current (Low Byte) R1000: -							
		13	D1000: Output Current (High Byte) R1000: -							
7		14	Terminal A2 Input (Low Byte)							
		15	Terminal A2 Input (High Byte)							
8		16	Main Circuit DC Voltage (Low Byte)							
		17	Main Circuit DC Voltage (High Byte)							
9		18	Error Code (Low Byte)							
		19	Error Code (High Byte)							
10		20	Alarm Code 2 (Low Byte)							
		21	Alarm Code 2 (High Byte)							
11		22	Alarm Code 3 (Low Byte)							
		23	Alarm Code 3 (High Byte)							
12		24	Terminal A3 Input (Low Byte)							
		25	Terminal A3 Input (High Byte)							
13		26	Digital Input (Low Byte)							
		27	Digital Input (High Byte)							
14		28	Terminal A1 Input (Low Byte)							
		29	Terminal A1 Input (High Byte)							
15		30	-							
		31	-							
16 - 19	32 - 39	Reserved								

Name	Description
Running	Running 0: Stop 1: Running
During Regenerative Operation	During Regenerative Operation 0: Converter not in regenerative operation 1: Converter in regenerative operation
Reset	Reset 0: - 1: Reset
During Run - Operation Ready	0: Not Ready 1: Ready
Ready	Ready 0: Not Ready 1: Ready
Alarm	Alarm 0: No Alarm 1: Alarm
Faulted	Faulted 0: No Fault 1: Fault
oPE	oPE 0: - 1: oPExx
Uv	Undervoltage 0: - 1: Undervoltage
LOCAL/REMOTE	Run command is from network 0: Run command is not from network 1: Run command is from network

Name	Description
Multi-Function Digital Output 1	Terminal M1/M2 (varies by converter model) 0: M1/M2 OFF 1: M1/M2 ON This function is enabled only when H2-01 is set to F. Note: The names of the digital outputs are different for different converter series.
Multi-Function Digital Output 2	Terminal M3/M4 (varies by converter model) 0: M3/M4 OFF 1: M3/M4 ON This function is enabled only when H2-02 is set to F. Note: The names of the digital outputs are different for different converter series.
Multi-Function Digital Output 3	Terminal M5/M6 (varies by converter model) 0: M5/M6 OFF 1: M5/M6 ON This function is enabled only when H2-03 is set to F. Note: The names of the digital outputs are different for different converter series.
Output Voltage	Converter Output Voltage
D1000: Voltage Command R1000: -	D1000: Converter Voltage Command R1000: -
D1000: Output Current R1000: -	D1000: Actual Output Current Monitors the converter output current. Unit: 0.01A Unit is not affected by Current Scale CS. R1000: -
Terminal A1 Input	MEMOBUS/Modbus (0x46) Monitor parameter U1-13
Terminal A2 Input	MEMOBUS/Modbus (0x4F) Monitor parameter U1-14
Terminal A3 Input	MEMOBUS/Modbus (0x50) Monitor parameter U1-15
Main Circuit DC Voltage	Main Circuit DC Voltage Monitor parameter U1-07
Error Code	U2-01 converted using fault code table.
Alarm Code 2	U2-01 converted using fault code table.
Alarm Code 3	U2-01 converted using fault code table.
Digital Inputs	Sets digital inputs 9-12 if the drive supports them.

◆ (Vendor Specific Yaskawa Electric (YE) Assy) High Speed/Torque Status Input - 166 (0xA6)

If an error occurs while trying to read from the dynamic parameters, the appropriate error bit in Assembly 166 will be set. If more information about the nature of the error is needed, the extended error status can be read explicitly through Class 4, Instance 0xA6, Attribute 0x64. This will return 20 Bytes with each dynamic parameter in Assembly 166 having a Byte dedicated to its extended error status.

*1 Selectable with F7-33 to F7-42.

Input Instance	Word	Byte	Bit 7	Bit 6	Bit 5	Bit 4	Bit 3	Bit 2	Bit 1	Bit 0	
166	0	0	Faulted	Alarm	Ready	During Run - Operation Ready	Reset	During Regenerative Operation	-	Running	
		1	-	-	Multi-Function Digital Output 3	Multi-Function Digital Output 2	Multi-Function Digital Output 1	LOCAL/REMOTE	Uv	oPE	
	1	2	Output Voltage (Low Byte)								
		3	Output Voltage (High Byte)								
	2	4	-								
		5	-								

11 Input Assemblies (Converter Produces)

Input Instance	Word	Byte	Bit 7	Bit 6	Bit 5	Bit 4	Bit 3	Bit 2	Bit 1	Bit 0
3		6	-							
		7	-							
4		8	D1000: Voltage Command (Low Byte) R1000: -							
		9	D1000: Voltage Command (High Byte) R1000: -							
5		10	Output Voltage (Low Byte)							
		11	Output Voltage (High Byte)							
6		12	D1000: Output Current (Low Byte) R1000: -							
		13	D1000: Output Current (High Byte) R1000: -							
7		14	Terminal A1 Input (Low Byte)							
		15	Terminal A1 Input (High Byte)							
8		16	Main Circuit DC Voltage (Low Byte)							
		17	Main Circuit DC Voltage (High Byte)							
9		18	Error Code (Low Byte)							
		19	Error Code (High Byte)							
10	20 - 21	Parameter [F7-33], Default: Alarm Code								
11	22 - 23	D1000: Parameter [F7-34], Default: Output Power R1000: Parameter [F7-34], Default: Not Used								
12	24 - 25	Parameter [F7-35], Default: Terminal A2 Input								
13	26 - 27	Parameter [F7-36], Default: Terminal S1 - S8 Input								
14	28 - 29	Parameter [F7-37], Default: Terminal A3 Input								
15	30 - 31	Parameter [F7-38], Default: Not Used								
16	32	-	-	-	-	-	-	-	Parameter [F7-39] (Low Byte), Default: NetCtrl	Parameter [F7-39] (Low Byte), Default: NetRef
		Parameter [F7-39] (High Byte), Default: Not Used								
17	34 - 35	Parameter [F7-40], Default: Converter Software Version								
18	36 - 37	Parameter [F7-41], Default: Not Used								
19	38 - 39	Parameter [F7-42], Default: Not Used								
20	40	-	-	-	-	-	-	-	Assy. 116 F7-32 Error	Assy. 116 F7-31 Error
		Assy. 116 F7-30 Error	Assy. 116 F7-29 Error	Assy. 116 F7-28 Error	Assy. 116 F7-27 Error	Assy. 116 F7-26 Error	Assy. 116 F7-25 Error	Assy. 116 F7-24 Error	Assy. 116 F7-23 Error	
21	42	-	-	-	-	-	-	-	Assy. 166 F7-42 Error	Assy. 166 F7-41 Error
		Assy. 166 F7-40 Error	Assy. 166 F7-39 Error	Assy. 166 F7-38 Error	Assy. 166 F7-37 Error	Assy. 166 F7-36 Error	Assy. 166 F7-35 Error	Assy. 166 F7-34 Error	Assy. 166 F7-33 Error	

Name	Description
Running	Running 0: Stop 1: Running
During Regenerative Operation	During Regenerative Operation 0: Converter not in regenerative operation 1: Converter in regenerative operation
Reset	Reset 0: - 1: Reset
During Run - Operation Ready	During Run - Operation Ready 0: Not Ready 1: Ready
Ready	Ready

Name	Description
	0: Not Ready 1: Ready
Alarm	Alarm 0: No Alarm 1: Alarm
Faulted	Faulted 0: No Fault 1: Fault
oPE	oPE 0: - 1: oPExx
Uv	Undervoltage 0: - 1: Undervoltage
LOCAL/REMOTE	Run command is from network 0: Run command is not from network 1: Run command is from network
Multi-Function Digital Output 1	Terminal M1/M2 (varies by converter model) 0: M1/M2 OFF 1: M1/M2 ON This function is enabled only when H2-01 is set to F. Note: The names of the digital outputs are different for different converter series.
Multi-Function Digital Output 2	Terminal M3/M4 (varies by converter model) 0: M3/M4 OFF 1: M3/M4 ON This function is enabled only when H2-02 is set to F. Note: The names of the digital outputs are different for different converter series.
Multi-Function Digital Output 3	Terminal M5/M6 (varies by converter model) 0: M5/M6 OFF 1: M5/M6 ON This function is enabled only when H2-03 is set to F. Note: The names of the digital outputs are different for different converter series.
Output Voltage	Converter Output Voltage
Voltage Command	Converter Voltage Command
D1000: Output Current R1000: -	D1000: Actual Output Current Monitors the converter output current. Unit: 0.01A Unit is not affected by Current Scale CS. R1000: -
Terminal A1 Input	MEMOBUS/Modbus (0x46) Monitor parameter U1-13
Main Circuit DC Voltage	Main Circuit DC Voltage Monitor parameter U1-07
Error Code	U2-01 converted using fault code table.
F7-33 Alarm Code	Programmable: MEMOBUS/Modbus (0x7F)
D1000: F7-34 Output Power R1000: F7-34 Not Used	D1000: Programmable: MEMOBUS/Modbus (0x47) Monitor parameter U1-08 R1000: -
F7-35 Terminal A2 Input	Programmable: MEMOBUS/Modbus (0x4F) Monitor parameter U1-14
F7-36 Terminal S1 - S12	Programmable: MEMOBUS/Modbus (0x49) Monitor parameter U1-10
F7-37 Terminal A3 Input	Programmable: MEMOBUS/Modbus (0x50)
F7-38 Not Used	-
F7-39 NetRef (Status)	Voltage command is from network 0: Voltage command is not from network 1: Voltage command is from network
F7-39 Not Used	-

11 Input Assemblies (Converter Produces)

Name	Description
F7-40 Converter Software Version	Programmable: MEMOBUS/Modbus (0x4D) Monitor parameter U1-25
F7-41 Not Used	-
F7-42 Not Used	-

Possible extended error codes are listed in [Table 11.1](#) and [Table 11.2](#). If an error occurs, extended error code 0x02 (Register number failure) is usually set.

Table 11.1 Extended Error Codes for Assembly 116/166

Error Code	Description
0x00	No Fault
0x01	Sub function code failure
0x02	Register Number
0x21	Limit check error failure
0x22	Write Failure
0x23	Write failure at Uv
0x24	Write failure at busy

Table 11.2 Extended Error Codes in Class 0x04 Instance 0xA6 Attribute 0x64

Dynamic Parameter	Byte Containing Extended Error Code
F7-23	Byte 0
F7-24	Byte 1
F7-25	Byte 2
F7-26	Byte 3
F7-27	Byte 4
F7-28	Byte 5
F7-29	Byte 6
F7-30	Byte 7
F7-31	Byte 8
F7-32	Byte 9
F7-33	Byte 10
F7-34	Byte 11
F7-35	Byte 12
F7-36	Byte 13
F7-37	Byte 14
F7-38	Byte 15
F7-39	Byte 16
F7-40	Byte 17
F7-41	Byte 18
F7-42	Byte 19

◆ (Vendor Specific Yaskawa Electric (YE) Assy) 8-Byte Dynamic Input 2 - 167 (0xA7)

Input Instance	Word	Byte	Bit 7	Bit 6	Bit 5	Bit 4	Bit 3	Bit 2	Bit 1	Bit 0
167	0	0	Faulted	Alarm	Ready	During Run - Operation Ready	Reset	During Regenerative Operation	-	Running
		1	-	-	Multi-Function Digital Output 3	Multi-Function Digital Output 2	Multi-Function Digital Output 1	LOCAL/REMOTE	Uv	oPE
	1	2	Output Voltage (Low Byte)							

Input Instance	Word	Byte	Bit 7	Bit 6	Bit 5	Bit 4	Bit 3	Bit 2	Bit 1	Bit 0
		3	Output Voltage (High Byte)							
	2	4 - 5	Parameter [F7-33], Default: Alarm Code							
	3	6 - 7	D1000: Parameter [F7-34], Default: Output Power R1000: Parameter [F7-34], Default: Not Used							

Name	Description
Running	Running 0: Stop 1: Running
During Regenerative Operation	During Regenerative Operation 0: Converter not in regenerative operation 1: Converter in regenerative operation
Reset	Reset 0: - 1: Reset
During Run - Operation Ready	During Run - Operation Ready 0: Not Ready 1: Ready
Ready	Ready 0: Not Ready 1: Ready
Alarm	Alarm 0: No Alarm 1: Alarm
Faulted	Faulted 0: No Fault 1: Fault
oPE	oPE 0: - 1: oPExx
Uv	Undervoltage 0: - 1: Undervoltage
LOCAL/REMOTE	Run command is from network 0: Run command is not from network 1: Run command is from network
Multi-Function Digital Output 1	Terminal M1/M2 (varies by converter model) 0: M1/M2 OFF 1: M1/M2 ON This function is enabled only when H2-01 is set to F. Note: The names of the digital outputs are different for different converter series.
Multi-Function Digital Output 2	Terminal M3/M4 (varies by converter model) 0: M3/M4 OFF 1: M3/M4 ON This function is enabled only when H2-02 is set to F. Note: The names of the digital outputs are different for different converter series.
Multi-Function Digital Output 3	Terminal M5/M6 (varies by converter model) 0: M5/M6 OFF 1: M5/M6 ON This function is enabled only when H2-03 is set to F. Note: The names of the digital outputs are different for different converter series.
Output Voltage	Converter Output Voltage
F7-33 Alarm Code	Programmable: MEMOBUS/Modbus (0x7F)
D1000: F7-34 Output Power R1000: F7-34 Not Used	D1000: Programmable: MEMOBUS/Modbus (0x47) Monitor parameter U1-08 R1000: -

◆ (Vendor Specific Yaskawa Electric (YE) Assy) 12-Byte Dynamic Input 4 - 168 (0xA8)

Input Instance	Word	Byte	Bit 7	Bit 6	Bit 5	Bit 4	Bit 3	Bit 2	Bit 1	Bit 0	
168	0	0	Faulted	Alarm	Ready	During Run - Operation Ready	Reset	During Regenerative Operation	-	Running	
		1	-	-	Multi-Function Digital Output 3	Multi-Function Digital Output 2	Multi-Function Digital Output 1	LOCAL/REMOTE	Uv	oPE	
	1	2	Output Voltage (Low Byte)								
		3	Output Voltage (High Byte)								
	2	4 - 5	Parameter [F7-33], Default: Alarm Code								
	3	6 - 7	D1000: Parameter [F7-34], Default: Output Power R1000: Parameter [F7-34], Default: Not Used								
	4	8 - 9	Parameter [F7-35], Default: Terminal A2 Input								
	5	10 - 11	Parameter [F7-36], Default: Terminal S1 - S8 Input								

Name	Description
Running	Running 0: Stop 1: Running
During Regenerative Operation	During Regenerative Operation 0: Converter not in regenerative operation 1: Converter in regenerative operation
Reset	Reset 0: - 1: Reset
During Run - Operation Ready	During Run - Operation Ready 0: Not Ready 1: Ready
Ready	Ready 0: Not Ready 1: Ready
Alarm	Alarm 0: No Alarm 1: Alarm
Faulted	Faulted 0: No Fault 1: Fault
oPE	oPE 0: - 1: oPExx
Uv	Undervoltage 0: - 1: Undervoltage
LOCAL/REMOTE	Run command is from network 0: Run command is not from network 1: Run command is from network
Multi-Function Digital Output 1	Terminal M1/M2 (varies by converter model) 0: M1/M2 OFF 1: M1/M2 ON This function is enabled only when H2-01 is set to F. Note: The names of the digital outputs are different for different converter series.
Multi-Function Digital Output 2	Terminal M3/M4 (varies by converter model) 0: M3/M4 OFF 1: M3/M4 ON This function is enabled only when H2-02 is set to F. Note: The names of the digital outputs are different for different converter series.
Multi-Function Digital Output 3	Terminal M5/M6 (varies by converter model)

Name	Description
	0: M5/M6 OFF 1: M5/M6 ON This function is enabled only when H2-03 is set to F. Note: The names of the digital outputs are different for different converter series.
Output Voltage	Converter Output Voltage
F7-33 Alarm Code	Programmable: MEMOBUS/Modbus (0x7F)
D1000: F7-34 Output Power R1000: F7-34 Not Used	D1000: Programmable: MEMOBUS/Modbus (0x47) Monitor parameter U1-08 R1000: -
F7-35 Terminal A2 Input	Programmable: MEMOBUS/Modbus (0x4F) Monitor parameter U1-14
F7-36 Terminal S1 - S12	Programmable: MEMOBUS/Modbus (0x49) Monitor parameter U1-10

◆ (Vendor Specific Yaskawa Electric (YE) Assy) 18-Byte Dynamic Input 7 - 169 (0xA9)

Input Instance	Word	Byte	Bit 7	Bit 6	Bit 5	Bit 4	Bit 3	Bit 2	Bit 1	Bit 0	
169	0	0	Faulted	Alarm	Ready	During Run - Operation Ready	Reset	During Regenerative Operation	-	Running	
		1	-	-	Multi-Function Digital Output 3	Multi-Function Digital Output 2	Multi-Function Digital Output 1	LOCAL/REMOTE	Uv	oPE	
	1	2	Output Voltage (Low Byte)								
		3	Output Voltage (High Byte)								
	2	4 - 5	Parameter [F7-33], Default: Alarm Code								
	3	6 - 7	D1000: Parameter [F7-34], Default: Output Power R1000: Parameter [F7-34], Default: Not Used								
	4	8 - 9	Parameter [F7-35], Default: Terminal A2 Input								
	5	10 - 11	Parameter [F7-36], Default: Terminal S1 - S8 Input								
	6	12 - 13	Parameter [F7-37], Default: Terminal A3 Input								
	7	14 - 15	Parameter [F7-38], Default: Not Used								
8	16	-	-	-	-	-	-	-	Parameter [F7-39] (Low Byte), Default: Net Ctrl	Parameter [F7-39] (Low Byte), Default: Net Ref	
	17	Parameter [F7-39] (High Byte), Default: Not Used									

Name	Description
Running	Running 0: Stop 1: Running
During Regenerative Operation	During Regenerative Operation 0: Converter not in regenerative operation 1: Converter in regenerative operation
Reset	Reset 0: - 1: Reset
During Run - Operation Ready	During Run - Operation Ready 0: Not Ready 1: Ready
Ready	Ready 0: Not Ready 1: Ready
Alarm	Alarm 0: No Alarm 1: Alarm

11 Input Assemblies (Converter Produces)

Name	Description
Faulted	Faulted 0: No Fault 1: Fault
oPE	oPE 0: - 1: oPExx
Uv	Undervoltage 0: - 1: Undervoltage
LOCAL/REMOTE	Run command is from network 0: Run command is not from network 1: Run command is from network
Multi-Function Digital Output 1	Terminal M1/M2 (varies by converter model) 0: M1/M2 OFF 1: M1/M2 ON This function is enabled only when H2-01 is set to F. Note: The names of the digital outputs are different for different converter series.
Multi-Function Digital Output 2	Terminal M3/M4 (varies by converter model) 0: M3/M4 OFF 1: M3/M4 ON This function is enabled only when H2-02 is set to F. Note: The names of the digital outputs are different for different converter series.
Multi-Function Digital Output 3	Terminal M5/M6 (varies by converter model) 0: M5/M6 OFF 1: M5/M6 ON This function is enabled only when H2-03 is set to F. Note: The names of the digital outputs are different for different converter series.
Output Voltage	Converter Output Voltage
F7-33 Alarm Code	Programmable: MEMOBUS/Modbus (0x7F)
D1000: F7-34 Output Power R1000: F7-34 Not Used	D1000: Programmable: MEMOBUS/Modbus (0x47) Monitor parameter U1-08 R1000: -
F7-35 Terminal A2 Input	Programmable: MEMOBUS/Modbus (0x4F) Monitor parameter U1-14
F7-36 Terminal S1 - S12	Programmable: MEMOBUS/Modbus (0x49) Monitor parameter U1-10
F7-37 Terminal A3 Input	Programmable: MEMOBUS/Modbus (0x50)
F7-38 Not Used	-
F7-39 NetRef (Status)	Voltage command is from network 0: Voltage command is not from network 1: Voltage command is from network
F7-39 NetCtrl	Run command is from network 0: Run command is not from network 1: Run command is from network
F7-39 Not Used	-

◆ (Vendor Specific Yaskawa Electric (YE) Assy) 24-Byte Dynamic Input 10 - 170 (0xAA)

Input Instance	Word	Byte	Bit 7	Bit 6	Bit 5	Bit 4	Bit 3	Bit 2	Bit 1	Bit 0	
170	0	0	Faulted	Alarm	Ready	During Run - Operation Ready	Reset	During Regenerative Operation	-	Running	
		1	-	-	Multi-Function Digital Output 3	Multi-Function Digital Output 2	Multi-Function Digital Output 1	LOCAL/REMOTE	Uv	oPE	
	1	2	Output Voltage (Low Byte)								
		3	Output Voltage (High Byte)								

Input Instance	Word	Byte	Bit 7	Bit 6	Bit 5	Bit 4	Bit 3	Bit 2	Bit 1	Bit 0
	2	4 - 5	Parameter [F7-33], Default: Alarm Code							
	3	6 - 7	D1000: Parameter [F7-34], Default: Output Power R1000: Parameter [F7-34], Default: Not Used							
	4	8 - 9	Parameter [F7-35], Default: Terminal A2 Input							
	5	10 - 11	Parameter [F7-36], Default: Terminal S1 - S8 Input							
	6	12 - 13	Parameter [F7-37], Default: Terminal A3 Input							
	7	14 - 15	Parameter [F7-38], Default: Not Used							
	8	16	-	-	-	-	-	-	Parameter [F7-39] (Low Byte), Default: Net Ctrl	Parameter [F7-39] (Low Byte), Default: Net Ref
		17	Parameter [F7-39], Default: Not Used (High Byte)							
	9	18 - 19	Parameter [F7-40], Default: Converter Software Version							
	10	20 - 21	Parameter [F7-41], Default: Not Used							
	11	22 - 23	Parameter [F7-42], Default: Not Used							

Name	Description
Running	Running 0: Stop 1: Running
During Regenerative Operation	During Regenerative Operation 0: Converter not in regenerative operation 1: Converter in regenerative operation
Reset	Reset 0: - 1: Reset
During Run - Operation Ready	During Run - Operation Ready 0: Not Ready 1: Ready
Ready	Ready 0: Not Ready 1: Ready
Alarm	Alarm 0: No Alarm 1: Alarm
Faulted	Faulted 0: No Fault 1: Fault
oPE	oPE 0: - 1: oPExx
Uv	Undervoltage 0: - 1: Undervoltage
LOCAL/REMOTE	Run command is from network 0: Run command is not from network 1: Run command is from network
Multi-Function Digital Output 1	Terminal M1/M2 (varies by converter model) 0: M1/M2 OFF 1: M1/M2 ON This function is enabled only when H2-01 is set to F. Note: The names of the digital outputs are different for different converter series.
Multi-Function Digital Output 2	Terminal M3/M4 (varies by converter model) 0: M3/M4 OFF 1: M3/M4 ON This function is enabled only when H2-02 is set to F. Note: The names of the digital outputs are different for different converter series.
Multi-Function Digital Output 3	Terminal M5/M6 (varies by converter model)

12 General Class Objects (Drive)

Name	Description
	0: M5/M6 OFF 1: M5/M6 ON This function is enabled only when H2-03 is set to F. Note: The names of the digital outputs are different for different converter series.
Output Voltage	Converter Output Voltage
F7-33 Alarm Code	Programmable: MEMOBUS/Modbus (0x7F)
D1000: F7-34 Output Power R1000: F7-34 Not Used	D1000: Programmable: MEMOBUS/Modbus (0x47) Monitor parameter U1-08 R1000: -
F7-35 Terminal A2 Input	Programmable: MEMOBUS/Modbus (0x4F) Monitor parameter U1-14
F7-36 Terminal S1 - S12	Programmable: MEMOBUS/Modbus (0x49) Monitor parameter U1-10
F7-37 Terminal A3 Input	Programmable: MEMOBUS/Modbus (0x50)
F7-38 Not Used	-
F7-39 NetRef (Status)	Voltage command is from network 0: Voltage command is not from network 1: Voltage command is from network
F7-39 NetCtrl	Run command is from network 0: Run command is not from network 1: Run command is from network
F7-39 Not Used	-
F7-40 Converter Software Version	Programmable: MEMOBUS/Modbus (0x4D) Monitor parameter U1-25
F7-41 Not Used	-
F7-42 Not Used	-

12 General Class Objects (Drive)

◆ Identity Object - 1 (Class 0x01)

■ Services Supported

Service Code No. (hex)	Service Name
01	Get Attribute All
05	Reset
0E	Get Attribute Single

■ Attributes Supported

Instance ID	Attribute	Name	Description	Get	Set	Size	Range	Default
0	1	Object Software Revision	Identity Object software revision	○	-	Word	-	1
1	1	Vendor ID	Manufacturer code. 44 (2C (Hex.)): Yaskawa Electric	○	-	Word	-	44
1	2	Device Type	Device profile. The profile for this product is an AC drive. 2: AC drive	○	-	Word	-	2
1	3	Product Code	Product codes determined by the manufacturer.	○	-	Word	-	*J
1	4	Revision	Software revision for the option.	○	-	Word	-	Depends on software
1	5	Status	Shows the communication status for the drive.	○	-	Word	-	0
1	6	Serial number	Option serial number.	○	-	Long	-	Each unit is unique

12 General Class Objects (Drive)

Instance ID	Attribute	Name	Description	Get	Set	Size	Range	Default
130	3	Data	Gateway Consume Assembly	○	○	Array 48 Bytes	-	00 00
150	3	Data	Same function as the MEMOBUS/Modbus Message Command (Input Assembly)	○	-	Array 5 Bytes	-	00 00 00 00 00
151	3	Data	Same function as the Speed/Torque Status (Input Assembly)	○	-	Array 8 Bytes	-	00 00 00 00 00 00 00 00
166	3	Data	Same function as the High Speed/Torque Status (Input Assembly)	○	-	Array 44 Bytes	-	00 00
167	3	Data	Same function as the 8 Byte Dynamic Input (Input Assembly)	○	-	Array 8 Bytes	-	00 00 00 00 00 00 00 00
168	3	Data	Same function as the 12 Byte Dynamic Input (Input Assembly)	○	-	Array 12 Bytes	-	00 00 00 00 00 00 00 00 00 00 00 00
169	3	Data	Same function as the 18 Byte Dynamic Input (Input Assembly)	○	-	Array 18 Bytes	-	00 00 00 00 00 00 00 00 00 00 00 00 00 00 00 00 00 00
170	3	Data	Same function as the 24 Byte Dynamic Input (Input Assembly)	○	-	Array 24 Bytes	-	00 00
180	3	Data	Gateway Produce Assembly	○	-	Array 48 Bytes	-	00 00

◆ Motor Data Object - 40 (Class 0x28)

Note:

This object is not available in D1000 and R1000. Refer to [Motor Data Object - 40 \(Class 0x28\) on page 99](#) for more information about this object compatible with D1000 and R1000.

■ Services Supported

Service Code No. (hex)	Service Name
0E	Get Attribute Single
10	Set Attribute Single

■ Attributes Supported

Instance ID	Attribute	Name	Description	Get	Set	Size	Range	Default
0	1	Object Software Revision	Motor Data Object software revision.	○	-	Word	-	1
1	3	Motor Type	Type of motor used. 3: PM motor 7: IM motor The setting value of this parameter is different for different A1-02 [Control Method Selection] setting. When A1-02 = 5, 6, 7 [PM Open Loop Vector, PM Advanced Open Loop Vector, PM Closed Loop Vector], value becomes 3 [PM Motor]. When A1-02 = 0, 1, 2, 3 [V/f Control, V/f Control with Encoder, Open Loop Vector, Closed Loop Vector], value becomes 7 [IM Motor]. Note: On GA700, GA800, CR700, HV600, and FP605 when A1-	○	-	Byte	-	Depends on A1-02 [Control Method Selection].

Instance ID	Attribute	Name	Description	Get	Set	Size	Range	Default
			02 = 8 [EZ Vector Control], this looks at E9-01 (E9-01 = 0 value becomes 7, E9-01 = 1 value becomes 3).					
1	6	Rated Current [0.1 A]	Motor rated current (E2-01). Displayed in 0.1 A units. Changes according to the current scale (CS).	○	○	Byte	-	Depends on capacity
1	7	Rated Voltage [1V]	Motor rated voltage (E1-01). Displayed in 1 V units. Changes according to the voltage scale (VS).	○	○	Byte	-	Depends on capacity

◆ Control Supervisor Object - 41 (Class 0x29)

Note:

This information applies to all products except D1000/R1000 converters. For the D1000/R1000 data for this object, refer to [Control Supervisor Object 41 \(Class 0x29\) on page 100](#).

■ Services Supported

Service Code No. (hex)	Service Name
0E	Get Attribute Single
10	Set Attribute Single
05	Reset

■ Attributes Supported

Instance ID	Attribute	Name	Description	Get	Set	Size	Range	Default
0	1	Object Software Revision	Revision number of the Control Supervisor Object.	○	-	Word	-	1
1	3	Run command 1 (FWD)	Forward Run Command 0: Stop 1: Forward Run	○	○	Byte	0, 1	0
1	4	Run command 2 (REV)	Reverse Run Command 0: Stop 1: Reverse Run	○	○	Byte	0, 1	0
1	5	NetCtrl (Command)	Run command is from network 0: Depends on b1-02 1: Run command is from network	○	○	Byte	0, 1	0
1	6	State	State 2: Not Ready 3: Ready (Stopped) 4: Enabled (Run command present) 5: Deceleration to Stop 6: Fault Stop 7: Fault	○	-	Byte	-	3
1	7	Running 1 (FWD)	Forward Running 0: Stop or Reverse Running 1: Forward Running	○	-	Byte	-	0
1	8	Running 2 (REV)	Reverse Running 0: Stop or Forward Running 1: Reverse Running	○	-	Byte	-	0
1	9	Ready	Ready 0: Not Ready 1: Ready	○	-	Byte	-	1
1	10	Faulted	Faulted 0: No Fault 1: Fault	○	-	Byte	-	0
1	11	Alarm	Alarm 0: No Alarm 1: Alarm	○	-	Byte	-	0
1	12	Fault Reset	Fault Reset 0: - 1: Fault Reset	○	○	Byte	0, 1	0

12 General Class Objects (Drive)

Instance ID	Attribute	Name	Description	Get	Set	Size	Range	Default
1	13	Fault Code	Current Fault Refer to page 92 for more information.	○	-	Word	-	0000
1	15	NetCtrl (Status)	Run command is from network 0: Run command is not from network 1: Run command is from network	○	-	Byte	-	0
1	16	EtherNet/IP Fault Mode	Normal 2 (Vendor Specific)	○	-	Byte	-	2
1	17	Force Fault	External Fault 0: - 1: External Fault [EF0] Triggered by the rising edge of the signal.	○	○	Byte	0, 1	0
1	18	Force Reset	External Fault status 0: - 1: External Fault [EF0] Triggered by the rising edge of the signal.	○	-	Byte	-	0
1	20	Net Idle Mode	Operation mode selection when communication is in Idle Mode. 0: Stop 1: Ignore 2: Stop if F6-01 is set to fault mode. 3: Forward Run 4: Reverse Run	○	○	-	0 - 4	

■ Option Fault Code Conversion Table

Drive Fault Code (Dec.) (MEMOBUS/Modbus 0080 (Hex.))	Option Fault Code (Hex.)	Description
0	0000	No Fault
2	3220	Uv1 [DC Bus Undervoltage]
3	5110	Uv2 [Control Power Undervoltage]
4	3222	Uv3 [Soft Charge Answerback Fault]
6	2120	GF [Ground Fault]
7	2300	oC [Overcurrent]
8	3210	ov [Overvoltage]
9	4200	oH [Heatsink Overheat]
10	4210	oH1 [Heatsink Overheat]
11	2220	oL1 [Motor Overload]
12	2200	oL2 [Drive Overload]
13	2221	oL3 [Overtorque Detection 1]
14	2222	oL4 [Overtorque Detection 2]
15	7110	rr [Dynamic Braking Transistor Fault]
16	7112	rH [Braking Resistor Overheat]
17	9000	EF3 [External Fault (Terminal S3)]
18	9000	EF4 [External Fault (Terminal S4)]
19	9000	EF5 [External Fault (Terminal S5)]
20	9000	EF6 [External Fault (Terminal S6)]
21	9000	EF7 [External Fault (Terminal S7)]
22	9000	EF8 [External Fault (Terminal S8)]
24	7310	oS [Overspeed]
25	7310	dEv [Speed Deviation]
26	7301	PGo [Encoder (PG) Feedback Loss]
27	3130	PF [Input Phase Loss]

Drive Fault Code (Dec.) (MEMOBUS/Modbus 0080 (Hex.))	Option Fault Code (Hex.)	Description
28	3130	LF [Output Phase Loss]
29	5210	oH3 [Motor Overheat (PTC Input)]
30	5300	oPr [Keypad Connection Fault]
31	6320	Err [EEPROM Write Error]
32	0	oH4 [Motor Overheat Fault (PTC Input)]
33	7500	CE [Modbus Communication Error]
34	7500	bUS [Option Communication Error]
37	8321	CF [Control Fault]
38	8313	SvE [Zero Servo Fault]
39	9000	EF0 [Option Card External Fault]
40	8000	FbL [PID Feedback Loss]
41	8000	UL3 [Undertorque Detection 1]
42	8000	UL4 [Undertorque Detection 2]
43	8000	oL7 [High Slip Braking Overload]
50	8000	dv1 [Z Pulse Fault]
51	8000	dv2 [Z Pulse Noise Fault Detection]
52	8000	dv3 [Inversion Detection]
53	8000	dv4 [Inversion Prevention Detection]
54	8000	LF2 [Output Current Imbalance]
55	8000	STo [Pull-Out Detection] Note: When using YASKAWA AC Drive GA500, GA700, GA800, CR700, HV600, or FP605 STPo [Motor Step-Out Detected] will be shown.
56	7000	PGoH [Encoder (PG) Hardware Fault]
59	1000	SEr [Speed Search Retries Exceeded]
65	8000	FbH [Excessive PID Feedback]
66	9000	EF1 [External Fault (Terminal S1)]
67	9000	EF2 [External Fault (Terminal S2)]
68	8000	oL5 [Mechanical Weakening Detection 1]
69	8000	UL5 [Mechanical Weakening Detection 2]
70	5000	CoF [Current Offset Fault]
73	8000	dWFL [DriveWorksEZ Fault]
77	5000	voF [Output Voltage Detection Fault]
78	7000	rF [Braking Resistor Fault]
79	7000	boL [Braking Transistor Overload Fault]
-	1000	Other faults

◆ AC/DC Drive Object - 42 (Class 0x2A)

Note:

This object is not available in D1000 and R1000. Refer to *AC/DC Drive Object - 42 (Class 0x2A) on page 101* for more information about this object compatible with D1000 and R1000.

■ Services Supported

Service Code No. (hex)	Service Name
0E	Get Attribute Single
10	Set Attribute Single

■ Attributes Supported

Instance ID	Attribute	Name	Description	Get	Set	Size	Range	Default
0	1	Object Software Revision	Revision number of AC/DC drive object	○	-	Word	-	1
1	3	Speed Agree	Speed Agree 0: - 1: Speed actual at speed reference	○	-	Byte	-	0
1	4	NetRef (Command)	Speed reference is from network 0: Speed reference is not from network 1: Speed reference is from network	○	-	Byte	-	0
1	6	Drive Mode	Drive Control Mode 0: OLV 0: OLV for PM (Read only) 0: Advanced OLV for PM (Read only) 1: V/f 2: V/f with PG 3: CLV 3: CLV for PM (Read only) Note: On GA500, GA700, GA800, CR700, HV600, and FP605 setting 1 also includes EZOLV (Read only). 1: V/f Control, EZ Vector Control	○	○	Byte	0 - 3	0
1	7	Speed Actual	Actual Drive Speed Unit depends on o1-03.	○	-	Word	-	3
1	8	Speed Reference	Speed Reference Unit depends on o1-03.	○	○	Word	-	0
1	9	Current Actual	Actual Output Current Monitors drive output current. Unit is 0.01 A for drives set up to 11 kW in Heavy Duty or Normal Duty and 0.1 A for drives set up for 15 kW and above. The maximum applicable motor output varies depending on the setting of C6-01 [Normal / Heavy Duty Selection].	○	-	Word	-	0
1	11	Torque Actual	Drive Output Torque Unit is affected by Torque Scale (TS)	○	-	Word	-	0
1	12	Torque Reference/Torque Limit	Torque Reference/Torque Limit Sets the Torque Reference/Torque Limit. Unit is affected by Torque Scale (TS). Sets the Torque Reference when using Torque Control [d5-01 = 1]. Sets the Torque Limit when using Speed Control [d5-01 = 0]. The Torque Reference/Torque Limit are disabled when F6-06 = 0.	○	○	Word	-	0
1	15	Power Actual [W]	Drive Output Power Unit is affected by Power Scale (PS).	○	-	Word	-	0
1	16	Input Voltage [V]	Drive Input Voltage [E1-01] Unit is affected by Voltage Scale (VS).	○	-	Word	-	Depends on capacity
1	17	Output Voltage [V]	Drive Output Voltage Unit is affected by Voltage Scale (VS).	○	-	Word	-	0
1	18	Accel Time [ms]	Acceleration Time 1 [C1-01] Units set in parameter C1-10. Unit is affected by Time Scale (TS).	○	○	Word	-	2710 (Hex.)
1	19	Decel Time [ms]	Acceleration Time 1 [C1-02] Units set in parameter C1-10. Unit is affected by Time Scale (TS).	○	○	Word	-	2710 (Hex.)
1	20	Low Speed Limit Percent of Max Speed	Frequency Reference Lower Limit [d2-02]	○	○	Word	0 - 1100	0

Instance ID	Attribute	Name	Description	Get	Set	Size	Range	Default
1	21	High Speed Limit Percent of Max Speed	Frequency Reference Upper Limit [d2-01]	○	○	Word	0 - 1100	3E8 (Hex.)
1	22	Speed Scale (-15 - +15)	Scale of Units for Speed Related Data Sets or verifies F7-17 [EtherNet/IP Speed Scaling Factor].	○	○	Byte	-15 - +15	0
1	23	Current Scale (-15 - +15)	Scale of Units for Current Related Data Sets or verifies F7-18 [EtherNet/IP Current Scaling Factor].	○	○	Byte	-15 - +15	0
1	24	Torque Scale (-15 - +15)	Scale of Units for Torques Related Data Sets or verifies F7-19 [EtherNet/IP Torques Scaling Factor].	○	○	Byte	-15 - +15	0
1	26	Power Scale (-15 - +15)	Scale of Units for Power Related Data Sets or verifies F7-20 [EtherNet/IP Power Scaling Factor].	○	○	Byte	-15 - +15	0
1	27	Voltage Scale (-15 - +15)	Scale of Units for Voltage Related Data Sets or verifies F7-21 [EtherNet/IP Voltage Scaling Factor].	○	○	Byte	-15 - +15	0
1	28	Time Scale (-15 - +15)	Scale of Units for Time Related Data Sets or verifies F7-22 [EtherNet/IP Timeout Scaling Factor].	○	○	Byte	-15 - +15	0
1	29	NetRef (Status)	Speed reference is from network 0: Speed reference is not from network 1: Speed reference is from network	○	-	Byte	-	0

◆ Base Energy Object 78 (Class 0x4E)

Note:

This object is not available in D1000 and R1000. Refer to [Base Energy Object 78 \(Class 0x4E\) on page 102](#) for more information about this object compatible with D1000 and R1000.

■ Services Supported

Service Code No. (hex)	Service Name
0E	Get Attribute Single
10	Set Attribute Single

■ Attributes Supported

Instance ID	Attribute	Name	Description	Get	Set	Size	Range	Default
0	1	Base Energy Software Revision	Base Energy Object software revision	○	-	Word	-	2
1	1	Energy/Resource Type	Type of energy managed	○	-	Word	-	Always 1 (Electrical)
1	2	Base Energy Object Capabilities	Energy Capabilities of this device	○	-	Word	-	Always 0 (Measured)
1	3	Energy Accuracy	Specifies the accuracy of power and energy metering results.	○	-	Word	-	Always 1000 (10%)
1	7	Consumed Energy Odometer	Consumed energy read from U4-10 [kWh, Lower 4 Digits] and U4-11 [kWh, Upper 5 Digits] in units of kWh.	○	-	ODOMETER Array of 5 words	0 - 999,999,999,999.999	-
1	8	Generated Energy Odometer	Always returns 0	○	-	ODOMETER Array of 5 words	0 - 999,999,999,999.999	-
1	9	Net Energy Odometer	The difference between Consumed energy and Generated energy in units of kWh.	○	-	SIGNED ODOMETER Array of 5 signed Words	-999,999,999,999.999 - 999,999,999,999.999	-

12 General Class Objects (Drive)

Instance ID	Attribute	Name	Description	Get	Set	Size	Range	Default
1	10	Energy Transfer Rate	Output Power read from monitor U1-08 [Output Power] in units of 1kW. In IEEE 754 REAL format.	○	-	REAL	Depends on capacity	-
1	12	Energy Type Specific Object Path	EPATH to Electrical Energy Object	○	-	STRUCT of UINT Size Padded EPATH	-	Always 02 20 4F 24 01

◆ Electrical Energy Object 79 (Class 0x4F)

Note:

This object is not available in D1000 and R1000. Refer to [Electrical Energy Object 79 \(Class 0x4F\) on page 103](#) for more information about this object compatible with D1000 and R1000.

■ Services Supported

Service Code No. (hex)	Service Name
0E	Get Attribute Single
10	Set Attribute Single

■ Attributes Supported

Instance ID	Attribute	Name	Description	Get	Set	Size	Range	Default
0	1	Electrical Energy Software Revision	Electrical Energy Object software revision	○	-	Word	-	2
1	1	Consumed Energy Odometer	Consumed energy read from U4-10 [kWh, Lower 4 Digits] and U4-11 [kWh, Upper 5 Digits] in units of kWh.	○	-	ODOMETER Array of 5 words	0 - 999,999,999,999.999	-
1	2	Generated Energy Odometer	Always returns 0	○	-	ODOMETER Array of 5 words	0 - 999,999,999,999.999	-
1	3	Net Energy Odometer	The difference between Consumed energy and Generated energy in units of kWh.	○	-	SIGNED ODOMETER Array of 5 signed Words	-999,999,999,999.999 - 999,999,999,999.999	-
1	41	Energy Type Specific Object Path	EPATH to Base Energy Object	○	-	STRUCT of UINT Size Padded EPATH	-	Always 02 20 4E 24 01

◆ TCP/IP Object 245 (Class 0xF5)

■ Services Supported

Service Code No. (hex)	Service Name
01	Get Attribute All
0E	Get Attribute Single
10	Set Attribute Single

■ Attributes Supported

Instance ID	Attribute	Name	Description	Get	Set	Size	Range	Default
0	1	Object Software Revision	Revision number of the TCP/IP Object	○	-	Word	-	3
1	1	Status	Bits 0-3 = Interface Status 0: Interface has not been configured 1: Interface Configuration is valid, obtained from BOOTP, DHCP, or NVRAM 2: Interface Configuration is valid and obtained from hardware settings 3: Reserved Bit 4 = Multicast Pending Bits 5-31 = Reserved	○	-	DWord	-	-

Instance ID	Attribute	Name	Description	Get	Set	Size	Range	Default
1	2	Configuration Capability	Bit 0 = BOOTP Client Bit 1 = DNS Client Bit 2 = DHCP Client Bit 3 = DHCP-DNS Update Bit 4 = Configuration Settable Bits 5-31 = Reserved	○	-	DWord	-	-
1	3	Configuration Control	Bits 0-3 = Startup Configuration 0: NVRAM 1: BOOTP 2: DHCP 3: Reserved Bit 4 = DNS Enabled (not supported) Bits 5-31 = Reserved	○	○	DWord	-	-
1	4	Physical Link	Struct of: Path Size: First 2 bytes Path: Remaining bytes	○	-	Struct	-	02 00 20 F6 24 01
1	5	Interface Configuration	Struct of: IP Address: Long Subnet Mask: Long Gateway Address: Long Name Server1: Long Name Server2: Long Domain Name: STRING	○	○	Struct	-	-
1	6	Host Name	Host Name	○	○	String	64 Characters	Null
1	10	SelectACD	Activates the use of ACD	○	○	BOOL	0, 1	1
1	11	Last Conflict Detected	AcdActivity	○	○	USINT	0, 1, 2, 3	0
			RemoteMAC	○	○	Array of 6 bytes	00 00 00 00 00 00 FF FF FF FF FF FF	00 00 00 00 00 00
			ArpPdu	○	○	Array of 28 bytes	-	00 00
1	13	Encapsulation Inactivity Timeout	Number of seconds of inactivity before TCP connection is closed.	○	○	UINT	1 s - 3600 s	120 s

Note:

“Get Attributes All” Service shall report in attribute ascending order.

◆ Ethernet Link Object 246 (Class 0xF6)

■ Services Supported

Service Code No. (hex)	Service Name
01	Get Attribute All
0E	Get Attribute Single
10	Set Attribute Single

■ Attributes Supported

Instance ID	Attribute	Name	Description	Get	Set	Size	Range	Default
0	1	Object Software Revision	Revision number of the Ethernet Link Object	○	-	Word	-	3
0	2	Max Instance	Number of Option Instances	○	-	UINT	-	2
0	3	Number of Instances	Number of Option Instances	○	-	UINT	-	2
1	1	Interface Speed	Interface speed currently in use	○	-	UDINT	-	-
1	2	Interface Flags	Bit 0 = Link Status Bit 1 = Duplex (0: half duplex, 1: full duplex) Bits 2-4 = Negotiation Status	○	-	DWord	-	-

12 General Class Objects (Drive)

Instance ID	Attribute	Name	Description	Get	Set	Size	Range	Default
			0: In progress 1: Auto-negotiate failed 2: Speed found, duplex not found Mode not detected 3: Successful 4: Not attempted Bit 5 = Manual Setting requires restart Bit 6 = Local hardware fault Bits 7-31 = Reserved					
1	3	Physical Address (MAC)	MAC address	○	-	Array of 6 Bytes	-	-
1	4	Interface Counters (Port 1)	In Octets	○	-	UDINT	0 - 4294967295	0
			In Ucast Packets	○	-	UDINT	0 - 4294967295	0
			In NUcast Packets	○	-	UDINT	0 - 4294967295	0
			In Discards	○	-	UDINT	0 - 4294967295	0
			In Errors	○	-	UDINT	0 - 4294967295	0
			In Unknown Protos	○	-	UDINT	0 - 4294967295	0
			Out Octets	○	-	UDINT	0 - 4294967295	0
			Out Ucast Packets	○	-	UDINT	0 - 4294967295	0
			Out NUcast Packets	○	-	UDINT	0 - 4294967295	0
			Out Discards	○	-	UDINT	0 - 4294967295	0
			Out Errors	○	-	UDINT	0 - 4294967295	0
1	5	Media Counters (Port 1)	Alignment Errors	○	-	UDINT	0 - 4294967295	0
			FCS Errors	○	-	UDINT	0 - 4294967295	0
			Single Collisions	○	-	UDINT	0 - 4294967295	0
			Multiple Collisions	○	-	UDINT	0 - 4294967295	0
			SQE Test Errors	○	-	UDINT	0 - 4294967295	0
			Deferred Trans-missions	○	-	UDINT	0 - 4294967295	0
			Late Collisions	○	-	UDINT	0 - 4294967295	0
			Excessive Collisions	○	-	UDINT	0 - 4294967295	0
			MAC Transmit Errors	○	-	UDINT	0 - 4294967295	0
			Carrier Sense Errors	○	-	UDINT	0 - 4294967295	0
			Frame Too Large	○	-	UDINT	0 - 4294967295	0
			MAC Receive Errors	○	-	UDINT	0 - 4294967295	0
1	6	Interface Control	Struct of: Control Bits: Word Bit 0 = Auto-negotiate Bit 1 = Forced Duplex Mode Bits 2-15 = Reserved Forced Int Speed: Word	-	○	Struct	-	-
1	10	Interface Label (Port 1)	Human readable identification	○	-	STRING	-	Port 1
1	11	Interface Capability (Port 1)	Capability bits	○	-	DWORD	-	000F (Hex.)
			Array of Struct of Speed/Duplex Options	○	-	Array of Struct of UINT USINT	-	-
			Interface Speed Interface Duplex Mode					
2	1	Interface Speed	Interface speed currently in use	○	-	UDINT	-	-
2	2	Interface Flags	Bit 0 = Link Status Bit 1 = Duplex (0: half duplex, 1: full duplex) Bits 2-4 = Negotiation Status 0: In progress 1: Auto-negotiate failed 2: Speed found, duplex not found Mode not detected 3: Successful	○	-	DWord	-	-

			4: Not attempted Bit 5 = Manual Setting requires restart Bit 6 = Local hardware fault Bits 7-31 = Reserved					
2	3	Physical Address (MAC)	MAC address	o	-	Array of 6 Bytes	-	-
2	4	Interface Counters (Port 2)	In Octets	o	-	UDINT	0 - 4294967295	0
			In Ucast Packets	o	-	UDINT	0 - 4294967295	0
			In NUCast Packets	o	-	UDINT	0 - 4294967295	0
			In Discards	o	-	UDINT	0 - 4294967295	0
			In Errors	o	-	UDINT	0 - 4294967295	0
			In Unknown Protos	o	-	UDINT	0 - 4294967295	0
			Out Octets	o	-	UDINT	0 - 4294967295	0
			Out Ucast Packets	o	-	UDINT	0 - 4294967295	0
			Out NUCast Packets	o	-	UDINT	0 - 4294967295	0
			Out Discards	o	-	UDINT	0 - 4294967295	0
			Out Errors	o	-	UDINT	0 - 4294967295	0
2	5	Media Counters (Port 2)	Alignment Errors	o	-	UDINT	0 - 4294967295	0
			FCS Errors	o	-	UDINT	0 - 4294967295	0
			Single Collisions	o	-	UDINT	0 - 4294967295	0
			Multiple Collisions	o	-	UDINT	0 - 4294967295	0
			SQE Test Errors	o	-	UDINT	0 - 4294967295	0
			Deferred Trans-missions	o	-	UDINT	0 - 4294967295	0
			Late Collisions	o	-	UDINT	0 - 4294967295	0
			Excessive Collisions	o	-	UDINT	0 - 4294967295	0
			MAC Transmit Errors	o	-	UDINT	0 - 4294967295	0
			Carrier Sense Errors	o	-	UDINT	0 - 4294967295	0
			Frame Too Large	o	-	UDINT	0 - 4294967295	0
MAC Receive Errors	o	-	UDINT	0 - 4294967295	0			
2	6	Interface Control	Struct of: Control Bits: Word Bit 0 = Auto-negotiate Bit 1 = Forced Duplex Mode Bits 2-15 = Reserved Forced Int Speed: Word	-	o	Struct	-	-
2	10	Interface Label (Port 2)	Human readable identification	o	-	STRING	-	Port 2
2	11	Interface Capability (Port 2)	Capability bits	o	-	DWORD	-	000F (Hex.)
			Array of Struct of Speed/Duplex Options Interface Speed Interface Duplex Mode	o	-	Array of Struct of UINT USINT	-	-

Note:

“Get Attributes All” Service shall report in attribute ascending order.

13 General Class Objects (Converter)

◆ Motor Data Object - 40 (Class 0x28)

■ Services Supported

Service Code No. (Hex.)	Service Name
0E	Get Attribute Single
10	Set Attribute Single

■ Attributes Supported

Instance ID	Attribute	Name	Description	Get	Set	Size	Range	Default
0	1	Object Software Revision	Motor Data Object software revision.	○	-	Word	-	1
1	3	Motor Type	Type of motor used. 0: Other than standard motor	○	-	Byte	-	0

◆ Control Supervisor Object 41 (Class 0x29)

■ Services Supported

Service Code No. (Hex.)	Service Name
0E	Get Attribute Single
10	Set Attribute Single
05	Reset

■ Attributes Supported

Instance ID	Attribute	Name	Description	Get	Set	Size	Range	Default
0	1	Object Software Revision	Motor Data Object software revision.	○	-	Word	-	1
1	3	Run 1 (Command)	D1000: 0: Stop 1: Run R1000: 0: Stop 1: Auto Run	○	○	Byte	0, 1	0
1	4	Run 2 (Command)	D1000: - R1000: 0: Stop 1: Force Run	○	○	Byte	0, 1	0
1	5	NetCtrl (Command)	Run command is from network 0: Depends on b1-02 1: Run command is from network	○	○	Byte	0, 1	0
1	6	State	State 2: Not Ready 3: Ready (Stopped) 4: Enabled (Run command present) 5: Deceleration to Stop 6: Fault Stop 7: Fault	○	-	Byte	-	3
1	7	Running 1	D1000: 0: Stop 1: Running R1000: 0: Stop 1: Auto Run	○	-	Byte	-	0
1	8	Running 2	D1000: - R1000: 0: Stop 1: Force Run	○	-	Byte	-	0
1	9	Ready	Ready 0: Not Ready 1: Ready	○	-	Byte	-	1
1	10	Faulted	Faulted 0: No Fault 1: Fault	○	-	Byte	-	0
1	11	Alarm	Alarm 0: No Alarm 1: Alarm	○	-	Byte	-	0
1	12	Fault Reset	Fault Reset 0: -	○	○	Byte	0, 1	0

Instance ID	Attribute	Name	Description	Get	Set	Size	Range	Default
			1: Fault Reset					
1	13	Fault Code	Current Fault Refer to page 92 for more information.	○	-	Word	-	0000
1	15	NetCtrl (Status)	Run command is from network 0: Run command is not from network 1: Run command is from network	○	-	Byte	-	0
1	16	EtherNet/IP Fault Mode	Normal 2 (Vendor Specific)	○	-	Byte	-	2
1	17	Force Fault	External Fault 0: - 1: External Fault [EF0] Triggered by the rising edge of the signal.	○	○	Byte	0, 1	0
1	18	Force Reset	External Fault status 0: - 1: External Fault [EF0] Triggered by the rising edge of the signal.	○	-	Byte	-	0
1	20	Net Idle Mode	Operation mode selection when communication is in Idle Mode. 0: Stop 1: Ignore 2: Stop if F6-01 is set to fault mode. 3: Forward Run 4: Reverse Run	○	○	-	0 - 4	

◆ AC/DC Drive Object - 42 (Class 0x2A)

■ Services Supported

Service Code No. (Hex.)	Service Name
0E	Get Attribute Single
10	Set Attribute Single

■ Attributes Supported

Instance ID	Attribute	Name	Description	Get	Set	Size	Range	Default
0	1	Object Software Revision	Revision number of AC/DC drive object	○	-	Word	-	1
1	4	NetRef (Command)	Voltage command is from network 0: Voltage command is not from network 1: Voltage command is from network	○	-	Byte	-	0
1	6	Drive Mode	Control Mode 0: Vendor Specific Control Mode	○	○	Byte	0	0
1	7	Voltage Actual	Voltage read from U1-52 [DC Bus DC Bus Voltage].	○	-	Word	-	-
1	8	Voltage Command	D1000: Sets with d8-01 [DC Bus Voltage Reference]. R1000: -	○	○	Word	-	-
1	9	Current Actual	D1000: Current read from U1-53 [DC Bus Side Current]. R1000: -	○	-	Word	-	0
1	15	Power Actual [W]	D1000: Output power read from U1-56 [DC Bus Side Power]. R1000: -	○	-	Word	-	0
1	17	Output Voltage [V]	Output voltage read from U1-52 [DC Bus Voltage Feedback].	○	-	Word	-	0
1	22	Voltage Scale (-15 - +15)	Scale of Units for Voltage Related Data Sets or verifies F7-21 [EtherNet/IP Voltage Scale Factor].	○	○	Byte	-15 - +15	0

13 General Class Objects (Converter)

Instance ID	Attribute	Name	Description	Get	Set	Size	Range	Default
1	23	Current Scale (-15 - +15)	Scale of Units for Current Related Data Sets or verifies F7-18 [EtherNet/IP Current Scale Factor].	○	○	Byte	-15 - +15	0
1	24	Torque Scale (-15 - +15)	Scale of Units for Torque Related Data Sets or verifies F7-19 [EtherNet/IP Torques Scale Factor].	○	○	Byte	-15 - +15	0
1	26	Power Scale (-15 - +15)	Scale of Units for Power Related Data Sets or verifies F7-20 [EtherNet/IP Power Scaling Factor].	○	○	Byte	-15 - +15	0
1	27	Voltage Scale (-15 - +15)	Scale of Units for Voltage Related Data Sets or verifies F7-21 [EtherNet/IP Voltage Scale Factor].	○	○	Byte	-15 - +15	0
1	28	Time Scale (-15 - +15)	Scale of Units for Time Related Data Sets or verifies F7-22 [EtherNet/IP Time Scaling].	○	○	Byte	-15 - +15	0
1	29	NetRef (Status)	Voltage command is from network 0: Voltage command is not from network 1: Voltage command is from network	○	-	Byte	-	0

◆ Base Energy Object 78 (Class 0x4E)

■ Services Supported

Service Code No. (Hex.)	Service Name
0E	Get Attribute Single
10	Set Attribute Single

■ Attributes Supported

Instance ID	Attribute	Name	Description	Get	Set	Size	Range	Default
0	1	Base Energy Software Revision	Base Energy Object software revision	○	-	Word	-	2
1	1	Energy/Resource Type	Type of energy managed	○	-	Word	-	Always 1 (Electrical)
1	2	Base Energy Object Capabilities	Energy Capabilities of this device	○	-	Word	-	Always 0 (Measured)
1	3	Energy Accuracy	Specifies the accuracy of power and energy metering results.	○	-	Word	-	Always 1000 (0.01%)
1	7	Consumed Energy Odometer	D1000: Consumed energy read from U9-01 [Electric Power (GWh)] to U9-03 [Electric Power (kWh)]. R1000: Always 0	○	-	ODOMETER Array of 5 words	0 - 999,999,999,999.999	-
1	8	Generated Energy Odometer	Regenerative power read from U9-04 [Regenerative Power (GWh)] to U9-06 [Regenerative Power (kWh)].	○	-	ODOMETER Array of 5 words	0 - 999,999,999,999.999	-
1	9	Net Energy Odometer	The difference between Consumed energy and Generated energy in units of kWh.	○	-	SIGNED ODOMETER Array of 5 signed Words	-999,999,999,999.999 - 999,999,999,999.999	-
1	10	Energy Transfer Rate	D1000: DC Bus power read from U1-56 [DC Bus Side Power] in units of 1kW. In IEEE 754 REAL format.	○	-	REAL	Depends on capacity	-
1	12	Energy Type Specific Object Path	EPATH to Electrical Energy Object	○	-	STRUCT of UINT Size Padded EPATH	-	Always 02 20 4F 24 01

◆ Electrical Energy Object 79 (Class 0x4F)

■ Services Supported

Service Code No. (Hex.)	Service Name
0E	Get Attribute Single
10	Set Attribute Single

■ Attributes Supported

Instance ID	Attribute	Name	Description	Get	Set	Size	Range	Default
0	1	Electrical Energy Software Revision	Electrical Energy Object software revision	○	-	Word	-	2
1	1	Consumed Energy Odometer	D1000: Consumed energy read from U9-01 [Electric Power (GWh)] to U9-03 [Electric Power (kWh)]. R1000: Always 0	○	-	ODOMETER Array of 5 words	0 - 999,999,999,999 .999	-
1	2	Generated Energy Odometer	Regenerative power read from U9-04 [Regenerative Power (GWh)] to U9-06 [Regenerative Power (kWh)].	○	-	ODOMETER Array of 5 words	0 - 999,999,999,999 .999	-
1	3	Net Energy Odometer	The difference between Consumed energy and Generated energy in units of kWh.	○	-	ODOMETER Array of 5 signed Words	-999,999,999,99 9,999 - 999,999,999,999 .999	-
1	9	Line Frequency	Power supply frequency read from U1-58 [Power Supply Frequency]. In IEEE 754 REAL format.	○	-	REAL	-	0
1	13	Average Current	Power supply current read from U1-55 [Power Supply Current]. In IEEE 754 REAL format.	○	-	REAL	-	0
1	18	Average L-N Voltage	Power supply voltage read from U1-54 [Power Supply Voltage]. In IEEE 754 REAL format.	○	-	REAL	-	0
1	39	Three Phase True Power Factor	D1000: Power factor read from U1-60 [Power Factor]. In IEEE 754 REAL format.	○	-	REAL	-	0
1	41	Energy Type Specific Object Path	EPATH to Base Energy Object	○	-	STRUCT of UINT Size Padded EPATH	-	Always 02 20 4E 24 01

14 Vendor-Specific (Yaskawa) Class Objects

◆ Yaskawa Drive Parameters Object - 100 (Class 0x64)

■ Services Supported

Service Code No. (Hex.)	Service Name
0E	Get Attribute Single
10	Set Attribute Single

Yaskawa Drive Parameters object is related to the parameters or monitor of Yaskawa drives. Not compatible with EtherNet/IP compatible drives from a different company. With this Class object any drive parameter or monitor with a MEMOBUS/Modbus address greater than 0x00FF can be accessed. The mapping of Class Object instance/attribute to MEMOBUS/Modbus address is as follows.

Given a typical MEMOBUS/Modbus Address of 0xXXYY

The EtherNet/IP Instance value is equal to XX

The EtherNet/IP Attribute value is equal to YY

As an example, to access parameter *b5-12* [MEMOBUS/Modbus Address = 0x01B0]

Class Object is 100 (0x64) (Always for this Class Object)

Instance = 0x01

Attribute = 0xB0

■ **Storing Changed Parameters**

Writing a zero to 0x0900 (Enter) stores changed parameters to the non-volatile memory of the drive. Writing a 0 to 0x0910 (Accept) allows the drive to use the changed parameters. Reading Enter Command 0x0900 or Accept Command 0x910 will always return a value of 0x0001.

Performing a RAM-ENTER to Store Register Data

Parameter *H5-11* is used to decide whether a RAM-ENTER will be done on the writes to registers in the drive. If *H5-11 = 1 [default]*, the option will issue the RAM-ENTER with the parameter writes. If *H5-11 = 0*, no RAM-ENTER is issued and an ENTER command must be explicitly sent by the user for the parameter to be activated after a write.

Explicit writes to RAM-ENTER (0x910) and ROM-ENTER (0x900) are handled as special cases. If a user writes a 0 to RAM-ENTER or ROM-ENTER, the command will be executed in the drive. If a user writes a 1 to those registers, the command will not be executed but returns a success to the explicit write on the network. Writing a value other than 0 or 1 will result in an error response of Invalid Attribute Value on the network.

Note:

Performing the RAM-ENTER increases the processing time of the writes and increases the response time to explicit writes.

■ **Attributes Supported**

Instance ID	Attribute	Name	Description	Get	Set	Size	Range	Default
0	1	Object Software Revision	Yaskawa Drive Parameters object software revision	○	-	Word	-	1
1	00	MEMOBUS/Modbus Register 0x0100	Language selection	○	○	Word	0 - 12	1
1	01	MEMOBUS/Modbus Register 0x0101	Parameter access level	○	○	Word	0 - 2	2
1	YY	MEMOBUS/Modbus Registers 0x0100 - 0x01FF	MEMOBUS/Modbus Registers 0x0100 - 0x01FF	○	○	Word	-	-
2	YY	MEMOBUS/Modbus Registers 0x0200 - 0x02FF	MEMOBUS/Modbus Registers 0x0200 - 0x02FF	○	○	Word	-	-
..	-	○	Word	-	-
255	YY	MEMOBUS/Modbus Registers 0xFF00 - 0xFFFF	MEMOBUS/Modbus Registers 0xFF00 - 0xFFFF	○	○	Word	-	-

Note:

1. Refer to *Explicit Message Communications Errors on page 110* for error codes.
2. Refer to the MEMOBUS/Modbus Data Table in the MEMOBUS/Modbus Communications chapter of the drive manual for a list of monitor data using the MEMOBUS/Modbus message area.

◆ **Yaskawa Monitor/Control Object - 125 (Class 0x7D)**

■ **Services Supported**

Service Code No. (Hex.)	Service Name
0E	Get Attribute Single
10	Set Attribute Single

Yaskawa Monitor/Control object is related to the parameters or monitors of Yaskawa drives. Not compatible with the EtherNet/IP compatible drives from another company. With this Class object any parameter or monitor with a MEMOBUS/Modbus address less than 0x0100 can be accessed. In this class, the most significant byte of MEMOBUS/Modbus address is always zero and the Instance ID remains at 1. Other than that, it is the same as Yaskawa Drive Parameters object 100 (Class 0x64).

Given a typical MEMOBUS/Modbus Address of 0x00YY

The EtherNet/IP Instance value is equal to 0x01

The EtherNet/IP Attribute value is equal to YY

As an example, to access Drive Status (MEMOBUS/Modbus Address = 0x002C)

Class Object is 125 (0x7D) (Always for this Class Object)

Instance = 0x01

Attribute = 0x2C

■ Attributes Supported

Instance ID	Attribute	Name	Description	Get	Set	Size	Range	Default
0	1	Object Software Revision	Shows Yaskawa Monitor/Control Object Software Revision.	○	-	Word	-	1
1	1	0x0001	Drive Command Bits	○	○	Word	-	0
1	2	0x0002	Frequency Instruction	○	○	Word	-	4
..	○	○	Word	-	-
1	255	0x00FF	Reserved	○	○	Word	-	-

Note:

1. Refer to *Explicit Message Communications Errors on page 110* for error codes.
2. Refer to the MEMOBUS/Modbus Data Table in the MEMOBUS/Modbus Communications chapter of the drive manual for a list of monitor data using the MEMOBUS/Modbus message area.

15 Web Interface

The option contains a series of web pages that let you use a standard web browser to view status and diagnostic information.

You can access the web page through a self-contained web server at port 80. Type the IP address of the option into a web browser to access the home page.

Example: "http://192.168.1.20"

If you do not know the IP address, use monitors *U6-80 to U6-83 [Option IP Address 1 to 4]* on the keypad to read the IP address of the option. Refer to [Table 6.1](#) for more information.

◆ Home Page

The screenshot shows the Yaskawa web interface for a CIPR-GA80U2004 drive. The main status is 'Not Ready'. The drive monitors section shows: Frequency Reference (55.00 Hz), Output Frequency (0.00 Hz), Output Current (0.0 A), DC Bus Voltage (326 VDC), and Torque Reference (0.0 %). Digital inputs S1-S8 are all off. Digital outputs M1-M2, M3-M4, and M5-M6 are all off. Analog inputs A1, A2, and A3 are all at 0.0%. The drive information section shows: Model (GA800), Full Model (CIPR-GA80U2004), Version (9015), and Serial Number (1W19Z32351XXXXX). The option card information shows: Model (JOHB-SMP3), Version (VST903000 (R0)), Protocol (EtherNet/IP), and Serial Number (J01067C5437XXXXX). The page footer indicates it is ©2021 Yaskawa America, Inc. and the update time is 1 second.

Figure 15.1 Home Page View

◆ EtherNet/IP Page

CIPR-GA80U2004
EtherNet/IP / JOHB-SMP3

Home EtherNet/IP Network Chart Login

No Active Connection

Originator IP Address	0.0.0.0
Timeout Multiplier	0
O2T RPI	0
O2T API	0
T2O RPI	0
T2O API	0
Consume Message Count	0
Produce Message Count	0

Downloads

EDS File: CIPR-GA80U2004 [Download](#)

©2021 Yaskawa America, Inc. All Rights Reserved - WEB 426 (R0) Update Time: 1 sec

Figure 15.2 EtherNet/IP Page View

◆ Network Page

CIPR-GA80U2004
EtherNet/IP / JOHB-SMP3

Home EtherNet/IP Network Chart Login

Identity

IP Address	192.168.1.20
Subnet Mask	255.255.255.0
Gateway Address	192.168.1.1
MAC Address	00:20:B5:88:15:B9
Address Mode	Static

Status

	Port 1	Port 2
Link Status	Active	Active
Speed	100 Mbps	100 Mbps
Duplex	Full	Full
Auto-Negotiation	Successful	Successful

Packet Counters

	Tx	Rx
Ok	4361	7242
Errors	0	0
Dropped	0	0

Interface Counters

	Port 1	Port 2
In Octets	99535	720335
In Ucast Packets	11	5214
In NUCast Packets	1023	928
Out Octets	82199	1387828
Out Ucast Packets	10	4334
Out NUCast Packets	919	987

Misc

Retry	0
Collisions	0
Current Connections	0

Media Counters

	Port 1	Port 2
Alignment Errors	0	0
FCS Errors	0	0
Single Collisions	0	0
Multiple Collisions	0	0
Late Collisions	0	0
Deferred Collisions	0	0
Excessive Collisions	0	0
Frame Too Large	0	0

©2021 Yaskawa America, Inc. All Rights Reserved - WEB 426 (R0) Update Time: 1 sec

Figure 15.3 Network Page View

◆ Chart Page

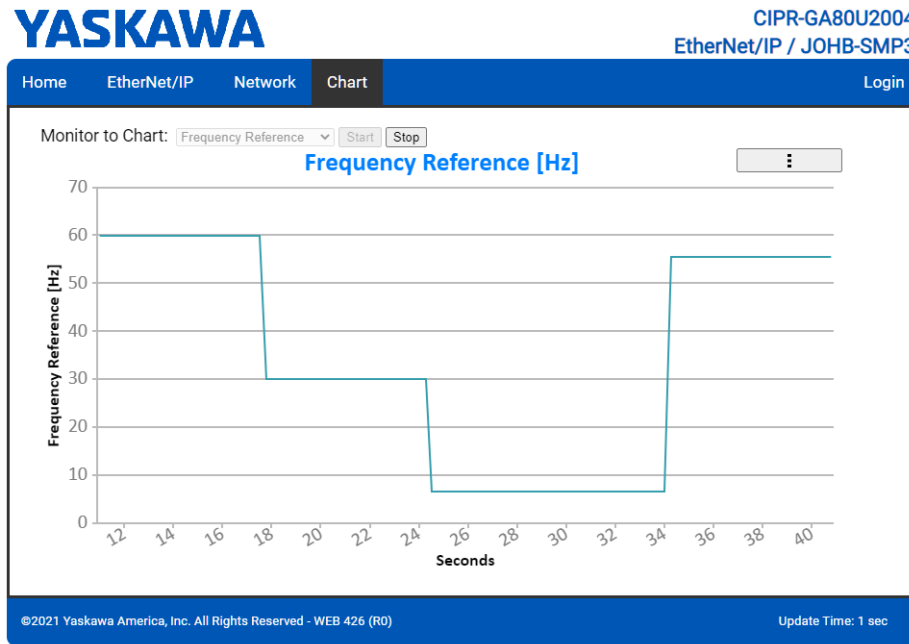

Figure 15.4 Chart Page View

◆ Email Alerts Page

Figure 15.5 Email Alerts Page View

◆ Parameter Access Page

Figure 15.6 Parameter Access Page View

◆ Settings Page

Figure 15.7 Settings Page View

16 Troubleshooting

◆ Drive-Side Error Codes

Drive-side error codes appear on the drive keypad. *Faults on page 108* lists causes of the errors and possible corrective actions. Refer to the drive Technical Manual for additional error codes that may appear on the drive keypad.

■ Faults

Both *bUS* [Option Communication Error] and *EF0* [Option Card External Fault] can appear as a fault. When a fault occurs, the keypad ALM LED stays lit. When an alarm occurs, the ALM LED flashes.

If communication stops while the drive is running, use these questions as a guide to help remove the fault:

- Is the communication line properly connected to the option? Is it loose?
- Is the option properly installed?
- Is the PLC program working? Is the controller/PLC CPU stopped?
- Did a momentary power loss interrupt communications?

Code	Name	Causes	Possible Solutions
bUS	Option Communication Error	The drive did not receive a signal from the controller.	<ul style="list-style-type: none"> Check for wiring errors. Correct the wiring.
		The communications cable wiring is incorrect.	
		An existing short circuit or communications disconnection	Check disconnected cables and short circuits and repair as needed
		A data error occurred due to electric interference	<ul style="list-style-type: none"> Prevent noise in the control circuit, main circuit, and ground wiring. If you identify a magnetic contactor as a source of noise, install a surge absorber to the contactor coil. Use only recommended cables or other shielded line. Ground the shield on the controller side or the drive input power side. Separate all communication wiring from drive power lines. Install an EMC noise filter to the drive power supply input. Decrease the effects of electrical interference from the controller.
		Option is damaged	If there are no problems with the wiring and the error continues to occur, replace the option.
		Connection Time-out	Check if the CPU of the controller is not stopped.
		Duplicate IP Address found on network	Change to a different IP address. If $F7-13 = 0$ [Address Mode at Startup = Static], change parameters F7-01 to F7-04 [IP Address 1 to 4].
EF0	Option Card External Fault	The option received an external fault from the controller.	<ol style="list-style-type: none"> Find the device that caused the external fault and remove the caus. Clear the external fault input from the controller.
		A programming error occurred on the controller side.	Examine the operation of the controller program.
oFA00	Option Not Compatible with Port	The option connected to connector CN5-A is not compatible.	Connect the option to the correct connector. <ul style="list-style-type: none"> Use connector CN5-A when you connect the option. To use other options, refer to those option manuals.
		Invalid DIP switch S1 setting	Set the option DIP switch S1 as shown in Figure 5.1. Monitor, U4-75 [Communication OPT Protocol] will display the DIP switch S1 setting.
oFA01	Option Card Fault (CN5-A)	The option connected to option port CN5-A was changed during run.	<ol style="list-style-type: none"> De-energize the drive. Connect the option to the correct option port.
oFA03, oFA04	Option Card Error (CN5-A)	A fault occurred in the option.	<ol style="list-style-type: none"> De-energize the drive. Make sure that the option is correctly connected to the connector. If the problem continues, replace the option.
oFA30 to oFA43	Option Card Connection Error (CN5-A)	A fault occurred in the option.	<ol style="list-style-type: none"> De-energize the drive. Make sure that the option is correctly connected to the connector. If the problem continues, replace the option.
oFb00	Option Not Compatible with Port	The option connected to connector CN5-B is not compatible.	Connect the option to the correct connector. <ul style="list-style-type: none"> Use connector CN5-A when you connect the option. To use other options, refer to those option manuals.
oFb02	Option Fault	An option of the same type is already installed in option port CN5-A, CN5-B, or CN5-C.	Connect the option to the correct option port.
oFC00	Option Fault (CN5-B)	The option connected to connector CN5-C is not compatible.	Connect the option to the correct connector. <ul style="list-style-type: none"> Use connector CN5-A when you connect the option. To use other options, refer to those option manuals.
oFC02	Option Fault	An option of the same type is already installed in option port CN5-A, CN5-B, or CN5-C.	Connect the option to the correct option port.
PSE	JOHB-SMP3 Protocol Set Error	Invalid DIP switch S1 setting	Set the option DIP switch S1 as shown in Figure 5.2. Monitor, U4-75 [Communication OPT Protocol] will display the DIP switch S1 setting.

■ Minor Faults and Alarms

Code	Name	Causes	Possible Solutions
CyPo	Cycle Power to Active Parameters	Comm. Option Parameter Not Upgraded	Re-energize the drive to update the communication option parameters.
PA1	PLC Alarm 1	Port 1 is at a link speed different from Port 2 (100 Mbps and 10 Mbps). Data will not be passed between the two ports in this condition.	When $F7-14 \neq 1$ [Duplex Mode Selection \neq Auto/Auto (Auto Negotiation/Auto Negotiation)], set the two connected ports to the same speed, $F7-15 = 101$ or 102 [Communication Speed Selection = [Not Used/No function] 10/100 Mbps (10 Mbps/100 Mbps) or [Not Used/No function] 100/10 Mbps (100 Mbps/10 Mbps)]. When $F7-14 = 1$ [Duplex Mode Selection = Auto/Auto (Auto Negotiation/Auto Negotiation)], make sure that the devices connected to the two ports have the same speed (both at 10 Mbps or both at 100 Mbps).

◆ bUS Fault Tolerance

■ bUS Fault Auto-Restart

Parameter *F6-14* [*bUS Fault Auto Reset Select*] will appear when the option is installed.

Setting *F6-14* = 0 [*Disabled*] or *F6-01* = 3 or greater (*Alarm only*) will not affect standard default drive behavior.

Setting *F6-14* = 1 [*Enabled*] AND *F6-01* ≠ 3 [*Fault*] will cause the following operation:

1. The bUS fault occurs after the *F7-16* [*Timeout Value*] delay and the Run command is removed from the drive.
2. Then the option throws a *bUS* fault to the drive.
3. When the condition is removed, the option commands a fault reset and returns control of the drive to the EtherNet/IP network.

Note:

The option will only read parameter *F6-01* and *F6-14* from the drive during power-up.

■ bUS Fault Delay

Parameter *F7-16* [*Timeout Value*] will appear when the option is installed. The setting value of *F7-16* is the length of time that the option will delay sending the *bUS* fault to the drive. The status LEDs on the option are not affected by the delay time set in *F7-16*; the LEDs will indicate the *bUS* condition immediately.

Note:

The option will only read parameter *F7-16* from the drive during power-up.

◆ Explicit Message Communications Errors

When there is a problem with a request message sent from the client in explicit communications, the drive will return one of the error codes shown in [Table 16.1](#).

Table 16.1 Communications Errors and Solutions

Error Code (Hex.)	Description	Cause	Possible Solutions
08	Service not supported	The service code is incorrect.	Correct the service code.
09	Invalid attribute value	The attribute is incorrect.	Correct the attribute.
0C	Object state conflict	Attempted to change a drive parameter that cannot be changed while the drive is running.	Stop the drive.
0E	Attribute not settable	Attempted to change a read-only attribute.	Correct the service code or attribute setting.
13	Not enough data	The data size is incorrect.	Correct the data size.
14	Attribute not supported	Attempted to execute a service not defined for the attribute.	Correct the service code or attribute setting.
15	Too much data	The data size is incorrect.	Correct the data size.
16	Object does not exist	An unsupported object was specified.	Correct the class or instance setting.
1F	Vendor-specific error	<ul style="list-style-type: none"> • Attempted to change a drive parameter that cannot be changed while the drive is running. • Attempted to change a drive parameter to a value outside the setting range. 	<ul style="list-style-type: none"> • Stop the drive. • Specify a value within the setting range.
20	Invalid parameter	Attempted to change to a data value outside the setting range.	Specify a data value within the setting range.

◆ Option Error Codes

■ Option Fault Monitors *U6-98* and *U6-99*

The option can declare error/warning conditions via drive monitor parameters on the drive keypad as shown in [Table 16.2](#).

Table 16.2 Option Fault Monitor Descriptions

Status	Fault Declared	Status Value (U6-98/U6-99)	Description
No faults	-	0	No faults
Fatal error occurred	<i>EF0</i>	3	Network sent a message to force this node to the fault state.

Status	Fault Declared	Status Value (U6-98/U6-99)	Description
Communications time-out (non-fatal)	<i>bUS</i>	1101	The node timer (Requested Packet Interval) timed out.
Duplicate IP Address	<i>bUS</i>	1102	This node and at least one other node have the same IP Address.
Default MAC Address	-	1103	Factory default MAC Address programmed into the option. Note: Return the option to Yaskawa or your nearest sales representative and request the setting change.
Network Link Down	<i>bUS</i>	1104	No network link to option.
Bad IP configuration	<i>bUS</i>	1106	<i>F7-13 = 0 [Address Mode at Startup = Static]</i> is set and the <i>F7-01 to F7-12 [IP Address 1 to 4, Subnet Mask 1 to 4, Gateway Address 1 to 4]</i> are set to an invalid configuration. Set the parameters to the correct values and cycle power on the drive.
Web Interface Setting Error	-	1110	Failure to read the web interface setting.

Two drive monitor parameters, *U6-98 [First Fault]* and *U6-99 [Current Fault]* assist the user in network troubleshooting.

- *U6-98* displays the first declared fault since the last power cycle. *U6-98* is only cleared upon drive power-up.
 - *U6-99* displays the present option status. *U6-99* is cleared upon a network-issued fault reset and upon power-up.
- If another fault occurs while the original fault is still active, parameter *U6-98* retains the original fault value and *U6-99* stores the new fault status value.

◆ Self RAM Check

Use these procedures to do a self RAM check for all areas including unused areas.

Note:

- The self RAM check completes in approximately 2.5 minutes.
- When you start the self RAM check, the drive will detect *oFA00 [Option Not Compatible with Port]*.

1. Set DIP switch S1 as shown in [Figure 16.1](#).

Note:

Use non-conductive tweezers or a tool with a tip width of approximately 0.5 mm (0.02 in) to set DIP switch S1.

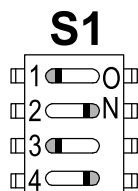

Figure 16.1 DIP Switch S1 Settings for the Self RAM Check

2. Apply power to the option.
This will start the self RAM check.
3. Look at the LEDs on the option to see the status of the self RAM check.
Refer to [Table 16.3](#) for more information.

Table 16.3 LED States during Self RAM Check

Self RAM Check Status	LED States	
	MS	NS
Checking	Lit in green	OFF
Successful termination	Lit in green	Lit in green
Abnormal termination	Lit in red	Lit in red

17 European Standards



Figure 17.1 CE Mark

The CE mark indicates compliance with European safety and environmental regulations.

European standards include the Machinery Directive for machine manufacturers, the Low Voltage Directive for electronics manufacturers, and the EMC Directive for controlling noise.

It is required for engaging in business and commerce in Europe.

This option displays the CE mark based on the EMC guidelines.

EMC Directive: 2014/30/EU

Drives used in combination with this option and devices used in combination with the drive must also be CE certified and display the CE mark.

When using drives displaying the CE mark in combination with other devices, it is ultimately the responsibility of the user to ensure compliance with CE standards. Verify that conditions meet European standards after setting up the device.

◆ EMC Directive Compliance

This option is tested according to European standard EN 61800-3:2004/A1:2012 and complies with the EMC Directive. The CE marking is declared based on the harmonized standards.

■ Option Installation

Verify the following installation conditions to make sure that other devices and machinery used with this option and drive also comply with EMC Directive:

1. Use dedicated shield cable for the option and external device (encoder, I/O device, controller), or run the wiring through a metal conduit.
2. Keep wiring as short as possible and ground the largest possible surface area of the shield to the metal panel according to [Figure 17.2](#), [Figure 17.3](#), and [Figure 17.4](#).

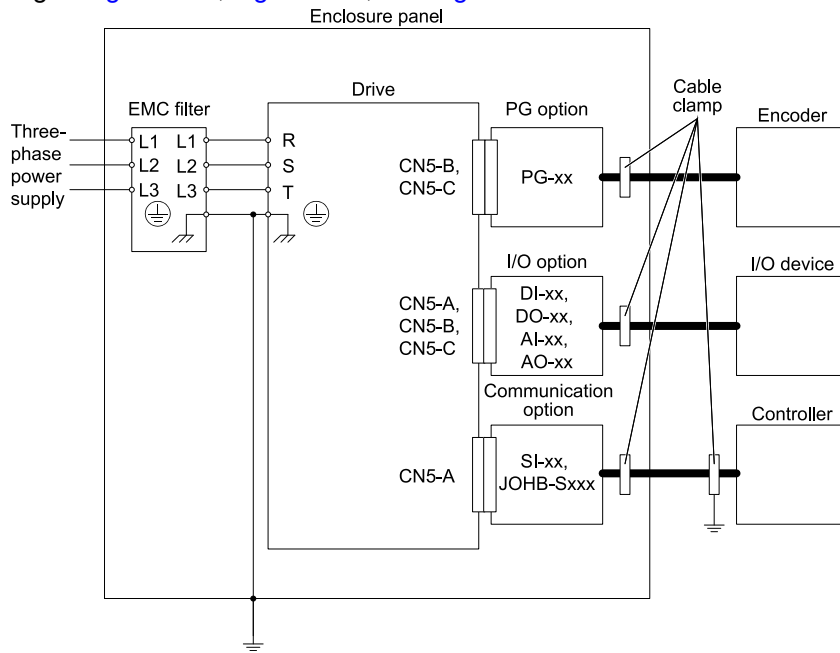

Figure 17.2 Option Installation for CE Compliance: 1000-Series, GA700, GA800, CR700

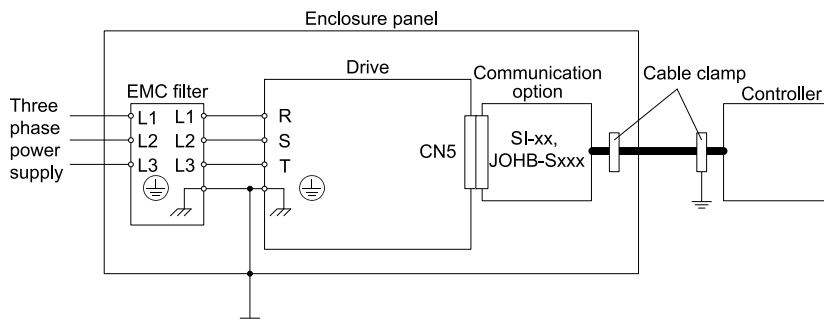

Figure 17.3 Option Installation for CE Compliance: GA500, HV600

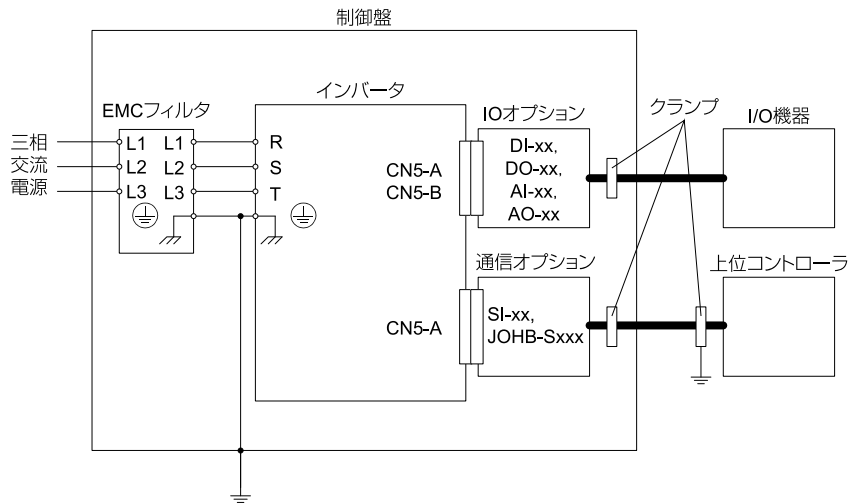
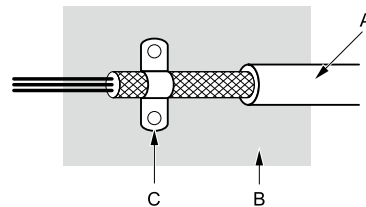

Figure 17.4 Option Installation for CE Compliance: FP605

3. Ground the largest possible surface area of the shield to the metal panel.
Yaskawa recommends using cable clamps.



A - Braided shield cable
B - Metal panel

C - Cable clamp (conductive)

Figure 17.5 Ground Area

18 Specifications

◆ Specifications

Table 18.1 Option Specifications

Items	Specifications
Model	JOHB-SMP3
Supported Messages	<ul style="list-style-type: none"> • Explicit: Explicit Class 3, Unconnected • I/O: Class 1, Listen Only, Input Only
I/O Assembly Instance	<ul style="list-style-type: none"> • Input: 13 types (4 - 47 Bytes) • Output: 13 types (4 - 47 Bytes)
EtherNet/IP Specification	Conformance Level CT 17: Passed
EtherNet/IP Profile	AC Drive
Recommended Connector Type	Shielded Cat5e cable
Physical Layer Type	Isolated Physical Layer Ethernet
IP Address Setting	Programmable from drive keypad or network
Communication Speed	Programmable from drive keypad or network: 10/100 Mbps, auto-negotiate
Number of Connections	<ul style="list-style-type: none"> • Explicit: 6 • I/O: 2
Duplex Mode	Half-forced, Auto-negotiate, Full-forced
Address Startup Mode	Static, BOOTP, DHCP
Ambient Temperature	-10°C - +50°C (14°F - 122°F)
Humidity	Up to 95% RH (non-condensing)
Storage Temperature	-20°C - +60°C (-4°F - 140°F) allowed for short-term transport of the product

Items	Specifications
Area of Use	Indoors and not near: <ul style="list-style-type: none"> • Oil mist, corrosive gas, flammable gas, or dust • Radioactive materials or flammable materials, including wood • Dangerous gases or fluids • Salt • Direct sunlight • Falling objects
Altitude	Up to 1000 m (3281 ft) Note: This option can be used at a maximum of 4000 m (13123 ft) depending on the model of the drive and the operating conditions. Refer to the drive manuals for more information.

19 Disposal

◆ Disposal Instructions

Correctly dispose of the product and packing material as specified by applicable regional, local, and municipal laws and regulations.

◆ WEEE Directive

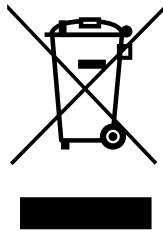

The wheeled bin symbol on this product, its manual, or its packaging identifies that you must recycle it at the end of its product life.

You must discard the product at an applicable collection point for electrical and electronic equipment (EEE). Do not discard the product with usual waste.

Revision History

Date of Publication	Revision Number	Section	Revised Content
June 2022	1	All	Revision: Reviewed and corrected entire documentation. Addition: Information on FP605
		2	Addition: For Yaskawa Customers in the North or South America Regions
		10	Deletion: EU Declaration of Conformity
April 2021	-	-	First edition

YASKAWA AC Drive Option EtherNet/IP Technical Manual

DRIVE CENTER (INVERTER PLANT)

2-13-1, Nishimiyaichi, Yukuhashi, Fukuoka, 824-8511, Japan
Phone: +81-930-25-2548 Fax: +81-930-25-3431
www.yaskawa.co.jp

YASKAWA ELECTRIC CORPORATION

New Pier Takeshiba South Tower, 1-16-1, Kaigan, Minatoku, Tokyo, 105-6891, Japan
Phone: +81-3-5402-4502 Fax: +81-3-5402-4580
www.yaskawa.co.jp

YASKAWA AMERICA, INC.

2121, Norman Drive South, Waukegan, IL 60085, U.S.A.
Phone: +1-800-YASKAWA (927-5292) or +1-847-887-7000 Fax: +1-847-887-7310
www.yaskawa.com

YASKAWA ELÉTRICO DO BRASIL LTDA.

777, Avenida Piraporinha, Diadema, São Paulo, 09950-000, Brasil
Phone: +55-11-3585-1100 Fax: +55-11-3585-1187
www.yaskawa.com.br

YASKAWA EUROPE GmbH

Hauptstraße 185, 65760 Eschborn, Germany
Phone: +49-6196-569-300 Fax: +49-6196-569-398
E-mail: info@yaskawa.eu.com
www.yaskawa.eu.com

YASKAWA ELECTRIC KOREA CORPORATION

18F, Hi Investment & Securities Building, 66 Yeoui-daero, Yeongdeungpo-gu, Seoul, 07325, Korea
Phone: +82-2-784-7844 Fax: +82-2-784-8495
www.yaskawa.co.kr

YASKAWA ASIA PACIFIC PTE. LTD

30A, Kallang Place, #06-01, 339213, Singapore
Phone: +65-6282-3003 Fax: +65-6289-3003
www.yaskawa.com.sg

YASKAWA ELECTRIC (THAILAND) CO., LTD.

59, 1F-5F, Flourish Building, Soi Ratchadapisek 18, Ratchadapisek Road, Huaykwang, Bangkok, 10310, Thailand
Phone: +66-2-017-0099 Fax: +66-2-017-0799
www.yaskawa.co.th

YASKAWA ELECTRIC (CHINA) CO., LTD.

22F, Link Square 1, No.222, Hubin Road, Shanghai, 200021, China
Phone: +86-21-5385-2200 Fax: +86-21-5385-3299
www.yaskawa.com.cn

YASKAWA ELECTRIC (CHINA) CO., LTD. BEIJING OFFICE

Room 1011, Tower W3 Oriental Plaza, No. 1, East Chang An Avenue,
Dong Cheng District, Beijing, 100738, China
Phone: +86-10-8518-4086 Fax: +86-10-8518-4082

YASKAWA ELECTRIC TAIWAN CORPORATION

12F, No. 207, Section 3, Beishin Road, Shindian District, New Taipei City 23143, Taiwan
Phone: +886-2-8913-1333 Fax: +886-2-8913-1513 or +886-2-8913-1519
www.yaskawa.com.tw

YASKAWA INDIA PRIVATE LIMITED

#17/A, Electronics City, Hosur Road, Bengaluru, 560 100 (Karnataka), India
Phone: +91-80-4244-1900 Fax: +91-80-4244-1901
www.yaskawaindia.in

YASKAWA

YASKAWA ELECTRIC
CORPORATION

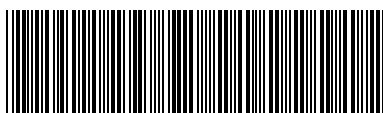

SIEPC730600J

In the event that the end user of this product is to be the military and said product is to be employed in any weapons systems or the manufacture thereof, the export will fall under the relevant regulations as stipulated in the Foreign Exchange and Foreign Trade Regulations. Therefore, be sure to follow all procedures and submit all relevant documentation according to any and all rules, regulations and laws that may apply.

Specifications are subject to change without notice for ongoing product modifications and improvements.

© 2021 YASKAWA ELECTRIC CORPORATION

MANUAL NO. SIEP C730600 0JB <1>-0
Published in Japan June 2022
22-3-23
Original Instructions