

YASKAWA AC Drive Option

Modbus TCP/IP

Technical Manual

Model JOHB-SMP3

To correctly use the product, read this manual thoroughly and keep it for easy reference, inspection, and maintenance.
Make sure that the end user receives this manual.

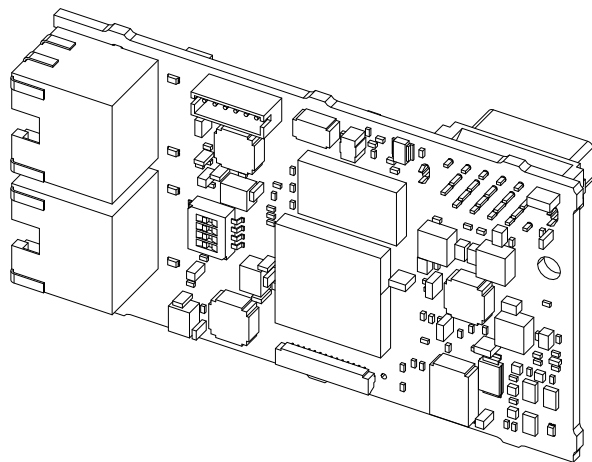

This Page Intentionally Blank

Table of Contents

1. Preface and Safety	5
Applicable Documentation	5
Glossary	5
Registered Trademarks	5
Supplemental Safety Information	5
Section Safety	6
2. Overview	6
Compatible Products	6
For Yaskawa Customers in the North or South America Regions	7
Install the Option on a GA500 Drive	7
3. Receiving	8
Option Package Contents	8
Installation Tools	9
4. Option Components	10
Option PCB Components	10
Communication Connector	10
Option LED States	10
5. Installation Procedure	11
Section Safety	11
Settings for the DIP Switch S1	12
Procedures to Install and Wire Options on a Drive	12
Procedure A	12
Procedure B	14
Procedure C	16
Procedure D	17
Communication Cable Specifications	19
Option Connection Diagram	19
Communication Topology Specifications	19
6. Related Drive Parameters	20
7. Modbus TCP/IP Messaging	25
Modbus TCP/IP Overview	25
Supported Modbus TCP/IP Commands	25
Drive Modbus TCP/IP Option Registers	25
High Speed Access Drive Modbus TCP/IP Option Registers	25
Types of Enter Commands	28
Enter Command Function Differences Depending on the Setting of H5-11	29

Message Format	29
Modbus TCP/IP Option Function Details	29
Modbus TCP/IP Exception Codes	35
Control Connection Timeout	35
8. Web Interface	36
Home Page	36
Modbus-TCP Page	36
Network Page	37
Chart Page	37
Email Alerts Page	38
Parameter Access Page	38
Settings Page	39
9. Troubleshooting	39
Drive-Side Error Codes	39
Fault	39
Minor Faults and Alarms	40
bUS Fault Tolerance	40
bUS Fault Auto-Restart	40
bUS Fault Delay	40
Option Error Codes	41
Option Fault Monitors <i>U6-98</i> and <i>U6-99</i>	41
Self RAM Check	41
10. European Standards	42
EMC Directive Compliance	42
Option Installation	42
11. Specifications	43
Specifications	43
12. Disposal	44
Disposal Instructions	44
WEEE Directive	44
Revision History	45

1 Preface and Safety

YASKAWA Electric supplies component parts for use in a wide variety of industrial applications. The selection and application of YASKAWA products remain the responsibility of the equipment designer or end user.

YASKAWA accepts no responsibility for the way its products are incorporated into the final system design. Under no circumstances should any YASKAWA product be incorporated into any product or design as the exclusive or sole safety control. Without exception, all controls should be designed to detect faults dynamically and fail safely under all circumstances. All products designed to incorporate a component part manufactured by YASKAWA must be supplied to the end user with appropriate warnings and instructions as to the safe use and operation of that part. Any warnings provided by YASKAWA must be promptly provided to the end user. YASKAWA offers an express warranty only as to the quality of its products in conforming to standards and specifications published in the manual. **NO OTHER WARRANTY, EXPRESS OR IMPLIED, IS OFFERED.** YASKAWA assumes no liability for any personal injury, property damage, losses, or claims arising from misapplication of its products.

◆ Applicable Documentation

Document	Description
JOHB-SMP3 Multi-Protocol EtherNet Quick Setup Procedure Manual No.: TOBP C730600 0H	Read this manual first. The manual provides information about wiring, settings, functions, and troubleshooting. The manual is packaged together with the product.
YASKAWA AC Drive Option Modbus TCP/IP Technical Manual Manual No.: SIEP C730600 0I (This book)	The technical manual contains detailed information about the option. Access the following sites to obtain the technical manual: U.S.: http://www.yaskawa.com Europe: http://www.yaskawa.eu.com Japan: http://www.e-mechatronics.com Other areas: Check the back cover of these manuals. For questions, contact Yaskawa or a Yaskawa representative.
YASKAWA AC Drive Manuals	Refer to the drive manual to connect with the option. Drive manuals contain basic installation and wiring information in addition to detailed parameter setting, fault diagnostic, and maintenance information. The manuals also include important information about parameter settings and tuning the drive. The Quick Start Guides are packaged with the drive. The most recent versions of these manuals are available for download on our documentation websites: U.S.: http://www.yaskawa.com Europe: http://www.yaskawa.eu.com Japan: http://www.e-mechatronics.com Other areas: Check the back cover of these manuals. For questions, contact Yaskawa or a Yaskawa representative.

◆ Glossary

Terms	Definition
Option	YASKAWA AC Drive Option JOHB-SMP3 with DIP Switches Set for Modbus TCP/IP
Keypad	<ul style="list-style-type: none"> • HOA Operator • LCD Operator • LED Operator • HOA Keypad • LCD Keypad • LED Keypad
Hex. (Example: 900 (Hex.))	Identifies a unit for hexadecimal number format.

◆ Registered Trademarks

- Modbus TCP/IP is a trademark of Modbus-IDA.
- All trademarks are the property of their respective owners.

◆ Supplemental Safety Information

Read and understand this manual before installing, operating, or servicing this option. The option must be installed according to this manual and local codes.

The following conventions are used to indicate safety messages in this manual. Failure to heed these messages could result in serious or possibly even fatal injury or damage to the products or to related equipment and systems.

⚠ DANGER This signal word identifies a hazard that will cause serious injury or death if you do not prevent it.

⚠ WARNING This signal word identifies a hazard that can cause death or serious injuries if you do not prevent it.

⚠ CAUTION This signal word identifies a hazardous situation, which, if not avoided, can cause minor or moderate injury.

NOTICE This signal word identifies a property damage message that is not related to personal injury.

■ Section Safety

General Precautions
<ul style="list-style-type: none"> The diagrams in this section may include options and drives without covers or safety shields to illustrate details. Be sure to reinstall covers or shields before operating any devices. The option should be used according to the instructions described in this manual. The diagrams in this manual are provided as examples only and may not pertain to all products covered by this manual. The products and specifications described in this manual or the content and presentation of the manual may be changed without notice to improve the product and/or the manual. Contact Yaskawa or a Yaskawa representative and provide the manual number shown on the front cover to order new copies of the manual.

⚠ DANGER Do not ignore the safety messages in this manual. If you ignore the safety messages in this manual, it will cause serious injury or death. The manufacturer is not responsible for injuries or damage to equipment.

⚠ WARNING *Electrical Shock Hazard.* Do not modify the drive or option circuitry. Failure to obey can cause serious injury or death, or cause damage to the drive or option and will void warranty. Yaskawa is not responsible for modifications of the product made by the user.

NOTICE *Damage to Equipment.* Do not use steam or other disinfectants to fumigate wood for packaging the drive. Use alternative methods, for example heat treatment, before you package the components. Gas from wood packaging fumigated with halogen disinfectants, for example fluorine, chlorine, bromine, iodine or DOP gas (phthalic acid ester), can cause damage to the drive.

2 Overview

This option provides a communications connection between the drive and a Modbus TCP/IP network. The option connects the drive to a Modbus TCP/IP network and facilitates the exchange of data.

Modbus TCP/IP is a communications link to connect industrial devices (such as smart motor controllers, operator interfaces, and variable frequency drives) as well as control devices (such as programmable controllers and computers) to a network.

Modbus TCP/IP is an open network standard.

Install the option on a drive to perform the following functions from a Modbus TCP/IP master device:

- Operate the drive
- Monitor the drive operation status
- Change drive parameter settings

◆ Compatible Products

You can use the option with these products:

Table 2.1 Compatible Products

Product Series	Model(s)	Software Version ^{*1}
A1000	CIMR-Ax2Axxxx	≥ 1020
	CIMR-Ax4A0002 - 4A0675	
	CIMR-Ax4A0930, 4A1200	≥ 3015
	CIMR-Ax5Axxxx	≥ 5040 ≥ 1017
D1000	CIMR-Dx2A0005 - 4A0370	≥ 2006
	CIMR-Dx4A0630	≥ 3014
R1000	CIMR-Rx2A03P5 - 4A0300	≥ 2102
U1000	CIMR-UxxAxxxx	≥ 1015
	CIMR-UxxExxxx	
	CIMR-UxxPxxxx	

Product Series	Model(s)	Software Version ^{*1}
	CIMR-UxxWxxxx	
Z1000	CIMR-ZxxAxxxx	≥ 1016
Z1000U	CIMR-ZxxUxxxx	≥ 6113
	CIMR-ZxxExxxx	
	CIMR-ZxxPxxxx	
	CIMR-ZxxWxxxx	
CR700	CIPR-CR70xxxxx	≥ 1012
GA500	CIPR-GA50xxxxx	≥ 1010
GA700	CIPR-GA70xxxxx	≥ 1010
GA800	CIPR-GA80xxxxx	≥ 9010
HV600	CIPR-HV60xxxxx	≥ 1011
FP605	CIPR-FP65xxxxx	≥ 1010

*1 Refer to “PRG” on the drive nameplate for the software version number.

Note:

Refer to the option package labeling in the field designated “PRG (four digit number)” to identify the option software version.

■ For Yaskawa Customers in the North or South America Regions

If your drive series is not shown in the “Compatible Products” section, refer to the web page below to confirm that your drive is compatible with this option. The web page shows a list of drives and compatible options, and also directs you to the correct installation manual and installation procedure for your drive.

Refer to the URL or scan QR code:



<https://www.yaskawa.com/mpe>

◆ Install the Option on a GA500 Drive

An option card mounting kit is necessary to install the option on a GA500 drive. The option card mounting kit model is: JOHB-GA50. This kit is sold separately.

Refer to the option card mounting kit manual for more information about installation.

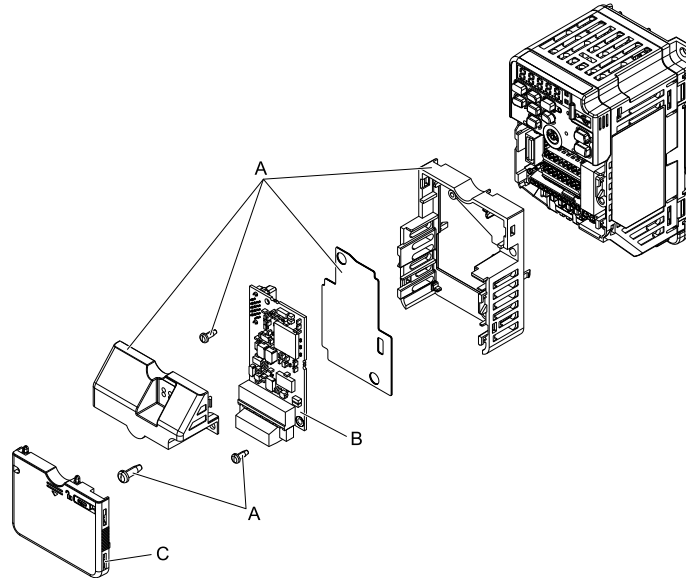

A - Option card mounting kit components (sold separately)
 B - Option
 C - Drive front cover

Figure 2.1 Option Card Mounting Kit (JOHB-GA50)

3 Receiving

After you receive the option package:

- Make sure that there is no damage to the option and no parts are missing. The Yaskawa warranty does not include damage from shipping. If there is damage to the option or other parts, contact the shipping company immediately.

NOTICE *Damage to Equipment. Do not use damaged parts to connect the drive and the option. Failure to comply could damage the drive and option.*

- Make sure that the model number on the option nameplate and the model number on the purchase order are the same. Refer to Figure 4.1 for more information.
- Contact the distributor where you purchased the option or contact Yaskawa or a Yaskawa representative about any problems with the option.

◆ Option Package Contents

Table 3.1 Contents of Package

Option Contents		Quantity
Option		1
Ground Wire *1		1
Screws (M3)		3 *2
LED Labels *3	1000-Series, Z1000U 	1
	GA500, GA700, GA800, CR700 	1

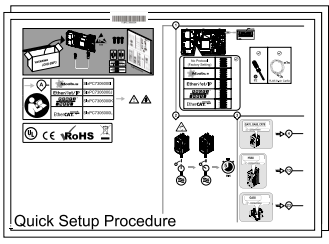
Option Contents		Quantity
	Z1000, HV600, FP605 *4	1
Quick Setup Procedure		1

- *1 GA500, GA700, GA800, and CR700 drives do not use the ground wire.
- *2 GA700, GA800, CR700, HV600, and FP605 drives use two screws only.
- *3 LED labels are located on this label sheet.

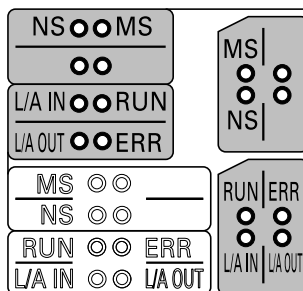

Figure 3.1 LED Label Sheet

- *4 The LED label has transparent background and white letters. Please make sure that you use the correct label for Z1000, HV600, or FP605.

◆ Installation Tools

You can use these tools to install the option to the drive:

- A Phillips screwdriver or slotted screwdriver *1.
- Non-conductive tweezers or a tool with a tip width of approximately 0.5 mm (0.02 in) to set DIP switch S1.
- A pair of diagonal cutting pliers.
- A small file or medium-grit sandpaper.

- *1 Phillips screw sizes are different for different drive capacities. Prepare different screwdrivers for different screw sizes.

4 Option Components

◆ Option PCB Components

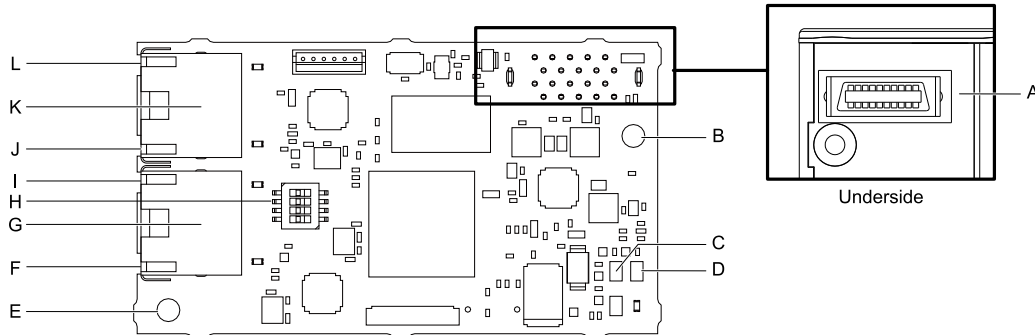

- A - Connector (CN5)
- B - Installation hole
- C - LED (NS) *1
- D - LED (MS) *1
- E - Ground terminal (FE) and installation hole *2
- F - Port 2 LED (10/100) *1
- G - Option modular connector CN1B (Port 2) (RJ45)
- H - DIP switch S1
- I - Port 2 LED (LINK/ACT) *1
- J - Port 1 LED (10/100) *1
- K - Option modular connector CN1A (Port 1) (RJ45)
- L - Port 1 LED (LINK/ACT) *1

Figure 4.1 Option PCB Components

*1 Refer to [Option LED States on page 10](#) for more information about the LEDs.
 *2 Connect the included ground wire during installation. The ground wire is not necessary for installation on GA700, GA800, and CR700 drives. For GA500 drives, connect the included ground wire to the separately-sold communication option case (model: JOHB-GA50).

◆ Communication Connector

Option connections CN1A (Port 1) and CN1B (Port 2) are connection points for customer-supplied Modbus TCP/IP network communication cables. These ports accept customer-supplied male 8-way Ethernet modular RJ45 connectors.

Table 4.1 Male 8-way Ethernet Modular Connector (Customer-Supplied)

Male 8-way Ethernet Modular Connector	Pin	Description
	1 (Pair 2)	Transmit data (TXD) +
	2 (Pair 2)	Transmit data (TXD) -
	3 (Pair 3)	Receive data (RXD) +
	4 (Pair 1)	Not used
	5 (Pair 1)	Not used
	6 (Pair 3)	Receive data (RXD) -
	7 (Pair 4)	Not used
	8 (Pair 4)	Not used

◆ Option LED States

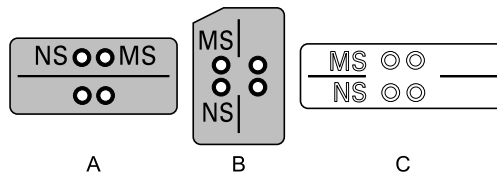

- A - 1000-Series, Z1000U
- B - GA500, GA700, GA800, CR700
- C - Z1000, HV600, FP605 *1

Figure 4.2 Option LED Labels

*1 LED label has transparent background and white letters. Please make sure that you use the correct label for Z1000, HV600, or FP605.

Wait 2 seconds minimum for the power-up diagnostic process to complete before you verify the LED states. Table 4.2 shows the operating status of the option LEDs after the power-up diagnostic LED sequence is complete.

Table 4.2 Option LED States

LED Name	Indication		Operating State	Description
	Color	State		
MS (Module Status)	-	OFF	Power supply off	There is no power to the drive.
	Green	ON	Option operating	The option is operating normally.
	Green	Flashing	Option initializing	The option is configuring an IP address.
	Red	ON	Fatal error occurred	The option detected a fatal (unrecoverable) error.
	Red	Flashing	Non-fatal error occurred	The option detected a non-fatal (recoverable) error.
NS (Network Status)	-	OFF	Power supply OFF or Offline	-
	Green	ON	Online communications established	The option is online and has established connections.
	Green	Flashing	Control connection active	The option is online and has an established and active control connection.
	Red	ON	Communications error (fatal)	The option detected a duplicate IP address.
10/100 *1	-	OFF	10 Mbps is established	
	Green	ON	100 Mbps is established	
LINK/ACT *1	-	OFF	Link is not established	
	Green	ON	Link is established	
	Green	Flashing	Link is established and there is network activity	

*1 To verify LED states, you must remove the drive front cover. Do not touch the drive main circuit terminal or circuit boards when you remove the drive front cover.

5 Installation Procedure

◆ Section Safety

⚠ DANGER *Electrical Shock Hazard. Do not examine, connect, or disconnect wiring on an energized drive. Before servicing, disconnect all power to the equipment and wait for the time specified on the warning label at a minimum. The internal capacitor stays charged after the drive is de-energized. The charge indicator LED extinguishes when the DC bus voltage decreases below 50 Vdc. When all indicators are OFF, measure for dangerous voltages to make sure that the drive is safe. If you do work on the drive when it is energized, it will cause serious injury or death from electrical shock.*

⚠ WARNING *Electrical Shock Hazard. Do not operate the drive when covers are missing. Replace covers and shields before you operate the drive. Use the drive only as specified by the instructions. Some figures in this section include drives without covers or safety shields to more clearly show the inside of the drive. If covers or safety shields are missing from the drive, it can cause serious injury or death.*

⚠ WARNING *Electrical Shock Hazard. Only let approved personnel install, wire, maintain, examine, replace parts, and repair the drive. If personnel are not approved, it can cause serious injury or death.*

⚠ WARNING *Electrical Shock Hazard. Do not remove covers or touch circuit boards while the drive is energized. If you touch the internal components of an energized drive, it can cause serious injury or death.*

⚠ WARNING *Electrical Shock Hazard. Do not use damaged wires, put too much force on the wiring, or cause damage to the wire insulation. Damaged wires can cause serious injury or death.*

⚠ WARNING *Fire Hazard. Tighten all terminal screws to the correct tightening torque. Connections that are too loose or too tight can cause incorrect operation and damage to the drive. Incorrect connections can also cause death or serious injury from fire.*

NOTICE *Damage to Equipment. When you touch the option, make sure that you observe correct electrostatic discharge (ESD) procedures. If you do not follow procedures, it can cause ESD damage to the drive circuitry.*

NOTICE *Damage to Equipment. Do not de-energize the drive while the drive is outputting voltage. Incorrect equipment sequencing can cause damage to the drive.*

NOTICE *Do not operate a drive or connected equipment that has damaged or missing parts. You can cause damage to the drive and connected equipment.*

NOTICE *Use Yaskawa connection cables or recommended cables only. Incorrect cables can cause the drive or option to function incorrectly.*

NOTICE *Damage to Equipment. Correctly connect the connectors. Incorrect connections can cause malfunction or damage to the equipment.*

NOTICE *Damage to Equipment. Make sure that all connections are correct after you install the drive and connecting peripheral devices. Incorrect connections can cause damage to the option.*

◆ Settings for the DIP Switch S1

Use the DIP switch S1 on the option to select the communication protocol.

Use non-conductive tweezers or a tool with a tip width of approximately 0.5 mm (0.02 in) to set DIP switch S1.

Figure 5.1 shows the default settings for the DIP switch S1.

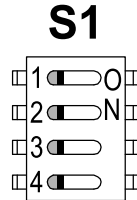

Figure 5.1 Default Settings for DIP Switch S1

When you use Modbus TCP/IP, set the DIP switch S1 as shown in Figure 5.2.

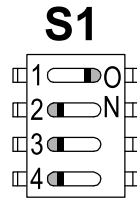

Figure 5.2 Settings for the DIP Switch S1

◆ Procedures to Install and Wire Options on a Drive

Procedures to install and wire the option are different for different drive models.

Refer to Table 5.1 to check the procedures to install and wire the option on a drive.

Table 5.1 Procedures to Install and Wire Options on a Drive

Product Series	Procedures to Install and Wire Options on a Drive	Page
A1000	Procedure A	12
D1000	Procedure A	12
R1000	Procedure A	12
U1000	Procedure A	12
Z1000U	Procedure A	12
Z1000	Procedure B	14
GA500	*1	-
GA700	Procedure C	16
GA800	Procedure C	16
CR700	Procedure C	16
HV600	Procedure D	17
FP605	Procedure D	17

*1 To install the option on GA500 drives, use the option mounting kit (JOHB-GA50) and manual.

■ Procedure A

This section shows the procedure to install and wire the option on a 1000-series drive.

Prepare the Drive for the Option

Correctly wire the drive as specified by the manual packaged with the drive. Make sure that the drive functions correctly. Refer to the drive manuals for more information.

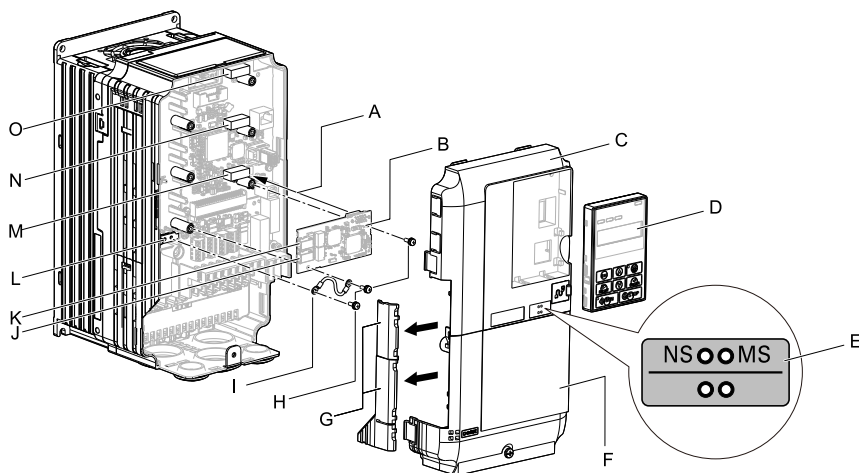

- | | |
|--|---|
| A - Insertion point for CN5 connector | I - Ground wire |
| B - Option | J - Option modular connector CN1B (Port 2) (RJ45) |
| C - Drive front cover | K - Option modular connector CN1A (Port 1) (RJ45) |
| D - Keypad | L - Drive grounding terminal (FE) |
| E - LED label | M - Connector CN5-A |
| F - Drive terminal cover | N - Connector CN5-B (Not available for communication option installation.) |
| G - Removable tabs for wire routing | O - Connector CN5-C (Not available for communication option installation.) |
| H - Included screws | |

Figure 5.3 Drive Components with Option

Install the Option

⚠ DANGER *Electrical Shock Hazard. Do not examine, connect, or disconnect wiring on an energized drive. Before servicing, disconnect all power to the equipment and wait for the time specified on the warning label at a minimum. The internal capacitor stays charged after the drive is de-energized. The charge indicator LED extinguishes when the DC bus voltage decreases below 50 Vdc. When all indicators are OFF, measure for dangerous voltages to make sure that the drive is safe. If you do work on the drive when it is energized, it will cause serious injury or death from electrical shock.*

NOTICE *Damage to Equipment. When you touch the option, make sure that you observe correct electrostatic discharge (ESD) procedures. If you do not follow procedures, it can cause ESD damage to the drive circuitry.*

Note:

You can only install this option into the CN5-A connector on the drive control board.

1. Shut off power to the drive and wait for the time specified on the drive warning label at a minimum. Make sure that the charge indicator LED is unlit, then remove the keypad and front cover. Refer to the drive manuals for more information.
2. Remove the keypad (D), front cover (C), and terminal cover (F).
3. Put the LED label (E) in the correct position on the drive front cover (C).
4. Install the option (B) into the CN5-A connector (M) on the drive and use one of the included screws (H) to put it in place.
5. Use one of the remaining included screws (H) to connect one end of the ground wire (I) to the ground terminal (L). Use the last remaining included screw (H) to connect the other end of the ground wire (I) to the remaining ground terminal and installation hole on the option (B).
Tighten the screws to a correct tightening torque:
 - 0.5 N·m to 0.6 N·m (4.4 lbf·in to 5.3 lbf·in)

Note:

The drive has only two ground terminal screw holes. When you connect three options, two options will share one ground terminal.

6. Route the option wiring.

Procedures to wire the option are different for different drive models.

 - You can route the option wiring through openings on the front cover of some models. Remove the perforated tabs on the left side of the front cover as shown in [Figure 5.4-A](#) to create the necessary openings on these models. To prevent damage to the cable from the cut end, treat the cut surface with sandpaper.
 - Route the option wiring inside the enclosure as shown in [Figure 5.4-B](#). Refer to the drive manuals for more information.

Note:

Isolate communication cables from main circuit wiring and other electrical and power lines.

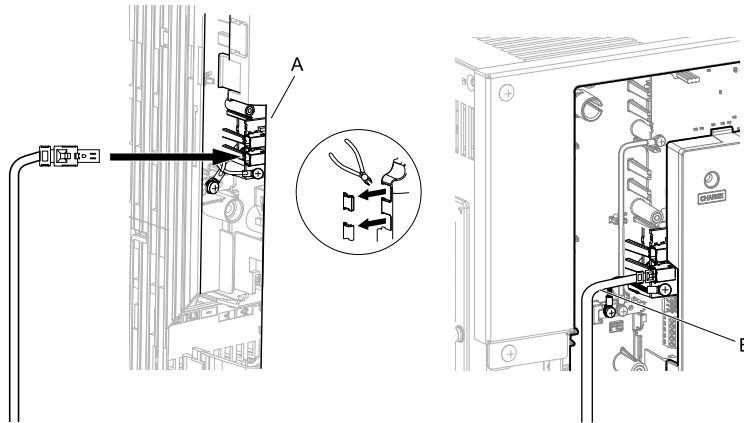

A - Route wires through the openings provided on the left side of the front cover. *1

B - Use the open space provided inside the drive to route option wiring.

Figure 5.4 Wire Routing Examples

*1 If there is wiring outside the enclosure, the drive will not meet Enclosed wall-mounted type (IP20/UL Type 1) requirements.

7. Firmly connect the Ethernet communication cables to CN1B (Port 2) (J), and/or CN1A (Port 1) (K).
Isolate communication cables from main circuit wiring and other electrical and power lines. Make sure that you firmly connect the cable end. Refer to [Communication Cable Specifications on page 19](#) for more information.
8. Reattach the front cover (C), terminal cover (F), and keypad (D).
Refer to the drive manuals for more information.
NOTICE Do not pinch cables between the front covers and the drive. Failure to comply could cause erroneous operation.
9. Set drive parameters in [Related Drive Parameters on page 20](#) for correct option performance.

■ Procedure B

This section shows the procedure to install and wire the option on a Z1000 drive.

Prepare the Drive for the Option

Correctly wire the drive as specified by the manual packaged with the drive. Make sure that the drive functions correctly. Refer to the drive manuals for more information.

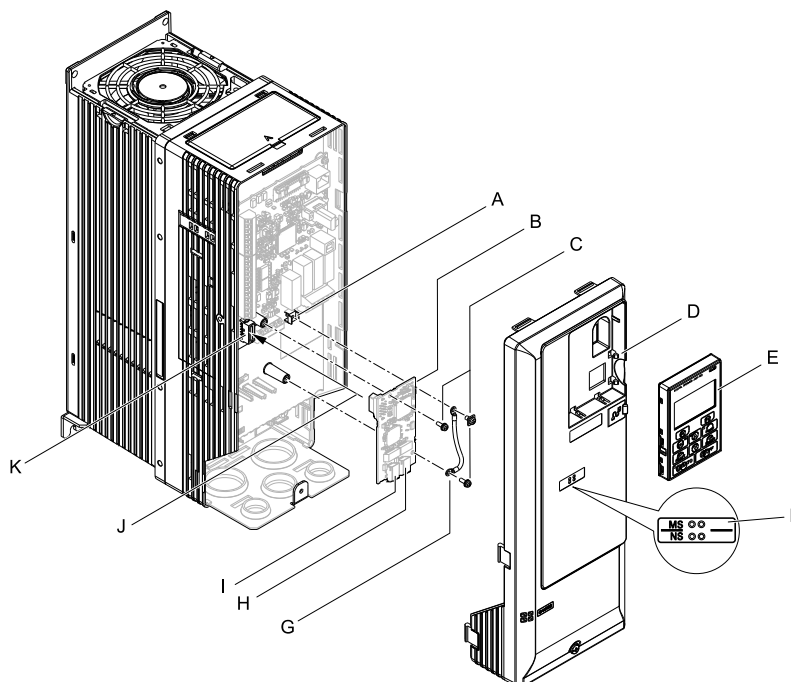

- | | |
|--|--|
| A - Drive grounding terminal (FE) | G - Ground wire |
| B - Option | H - Option modular connector CN1B (Port 2) (RJ45) |
| C - Included screws | I - Option modular connector CN1A (Port 1) (RJ45) |
| D - Drive front cover | J - Insertion point for CN5 connector |
| E - Keypad | K - Connector CN5 |
| F - LED label | |

Figure 5.5 Drive Components with Option

Install the Option

⚠ DANGER *Electrical Shock Hazard. Do not examine, connect, or disconnect wiring on an energized drive. Before servicing, disconnect all power to the equipment and wait for the time specified on the warning label at a minimum. The internal capacitor stays charged after the drive is de-energized. The charge indicator LED extinguishes when the DC bus voltage decreases below 50 Vdc. When all indicators are OFF, measure for dangerous voltages to make sure that the drive is safe. If you do work on the drive when it is energized, it will cause serious injury or death from electrical shock.*

NOTICE *Damage to Equipment. When you touch the option, make sure that you observe correct electrostatic discharge (ESD) procedures. If you do not follow procedures, it can cause ESD damage to the drive circuitry.*

- Shut off power to the drive and wait for the time specified on the drive warning label at a minimum. Make sure that the charge indicator LED is unlit, then remove the keypad and front cover. Refer to the drive manuals for more information.
- Remove the keypad (E) and front cover (D).
- Put the LED label (F) in the correct position on the drive front cover (D).
- Install the option (B) into the CN5 connector (K) on the drive and use one of the included screws (C) to put it in place.
- Use one of the remaining included screws (C) to connect one end of the ground wire (G) to the ground terminal (A). Use the last remaining included screw (C) to connect the other end of the ground wire (G) to the remaining ground terminal and installation hole on the option (B).
Tighten the screws to a correct tightening torque:
 - 0.5 N·m to 0.6 N·m (4.4 lbf·in to 5.3 lbf·in)
- Firmly connect the Ethernet communication cables to CN1B (Port 2) (H), and/or CN1A (Port 1) (I). Isolate communication cables from main circuit wiring and other electrical and power lines. Make sure that you firmly connect the cable end. Refer to [Communication Cable Specifications on page 19](#) for more information.
- Reattach the drive front cover (D) and the keypad (E).
Refer to the drive manuals for more information.

NOTICE *Do not pinch cables between the front covers and the drive. Failure to comply could cause erroneous operation.*

8. Set drive parameters in *Related Drive Parameters on page 20* for correct option performance.

■ Procedure C

This section shows the procedure to install and wire the option on a GA700, GA800, or CR700 drive.

Prepare the Drive for the Option

Correctly wire the drive as specified by the manual packaged with the drive. Make sure that the drive functions correctly. Refer to the drive manuals for more information.

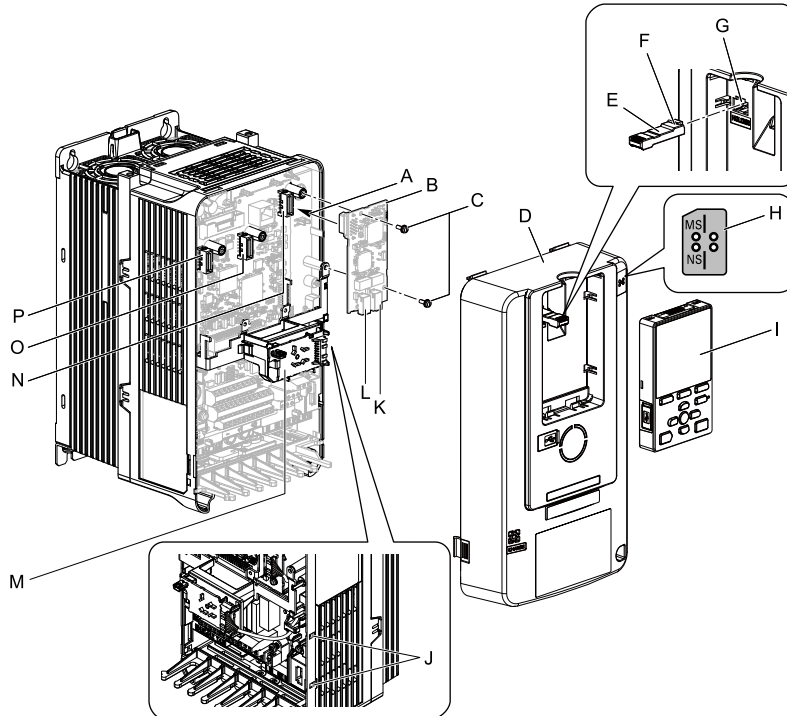

- | | |
|--|---|
| A - Insertion point for CN5 connector | I - Keypad |
| B - Option | J - LED Status Ring board temporary placement holes |
| C - Included screws | K - Option modular connector CN1B (Port 2) (RJ45) |
| D - Drive front cover | L - Option modular connector CN1A (Port 1) (RJ45) |
| E - Keypad connector | M - LED Status Ring board |
| F - Keypad connector tab | N - Connector CN5-A |
| G - Holder | O - Connector CN5-B (Not available for communication option installation.) |
| H - LED label | P - Connector CN5-C (Not available for communication option installation.) |

Figure 5.6 Drive Components with Option

Install the Option

⚠ DANGER *Electrical Shock Hazard. Do not examine, connect, or disconnect wiring on an energized drive. Before servicing, disconnect all power to the equipment and wait for the time specified on the warning label at a minimum. The internal capacitor stays charged after the drive is de-energized. The charge indicator LED extinguishes when the DC bus voltage decreases below 50 Vdc. When all indicators are OFF, measure for dangerous voltages to make sure that the drive is safe. If you do work on the drive when it is energized, it will cause serious injury or death from electrical shock.*

NOTICE *Damage to Equipment. When you touch the option, make sure that you observe correct electrostatic discharge (ESD) procedures. If you do not follow procedures, it can cause ESD damage to the drive circuitry.*

Note:

You can only install this option into the CN5-A connector on the drive control board.

1. Put the LED label (H) in the correct position on the drive front cover (D).
2. Shut off power to the drive and wait for the time specified on the drive warning label at a minimum. Make sure that the charge indicator LED is unlit, then remove the keypad and front cover. Refer to the drive manuals for more information.

3. Remove the keypad (I) and front cover (D).

Note:

Remove the keypad, then move the keypad connector (E) to the holder (G) on the drive, then remove the front cover.

4. Carefully remove the LED Status Ring board (M) and put it in the temporary placement holes (J) on the right side of the drive.
Refer to the drive manuals for more information.

NOTICE Do not remove the LED Status Ring board cable connector. If you disconnect the LED Status Ring board, it can cause incorrect operation and damage to the drive.

5. Install the option (B) into the CN5-A connector (N) on the drive and use the included screws (C) to put it in place.

Tighten the screws to a correct tightening torque:

- 0.5 N·m to 0.6 N·m (4.4 lbf·in to 5.3 lbf·in)

Note:

1. A ground wire is not necessary. Do not use the ground wire.
2. Only two screws are necessary to install the option on a GA700, GA800, and CR700 drive.

6. Firmly connect the Ethernet communication cables to CN1B (Port 2) (K), and/or CN1A (Port 1) (L).
Isolate communication cables from main circuit wiring and other electrical and power lines. Make sure that you firmly connect the cable end. Refer to [Communication Cable Specifications on page 19](#) for more information.

Note:

Maximum transmission distance is 100 m (328 ft). Minimum wiring distance between stations is 0.2 m (7.9 in).

7. Reattach the LED Status Ring board (M), front cover (D), and keypad (I).

Refer to the drive manuals for more information.

NOTICE Do not pinch cables between the front cover or the LED Status Ring board and the drive. Failure to comply could cause erroneous operation.

Note:

- Replace the keypad connector (E), then install the keypad.
- Put the keypad connector tab (F) into the holder when you install the keypad connector to the holder.

8. Set drive parameters in [Related Drive Parameters on page 20](#) for correct option performance.

■ Procedure D

This section shows the procedure to install and wire the option on HV600 and FP605 drives.

Prepare the Drive for the Option

Correctly wire the drive as specified by the manual packaged with the drive. Make sure that the drive functions correctly. Refer to the drive manuals for more information.

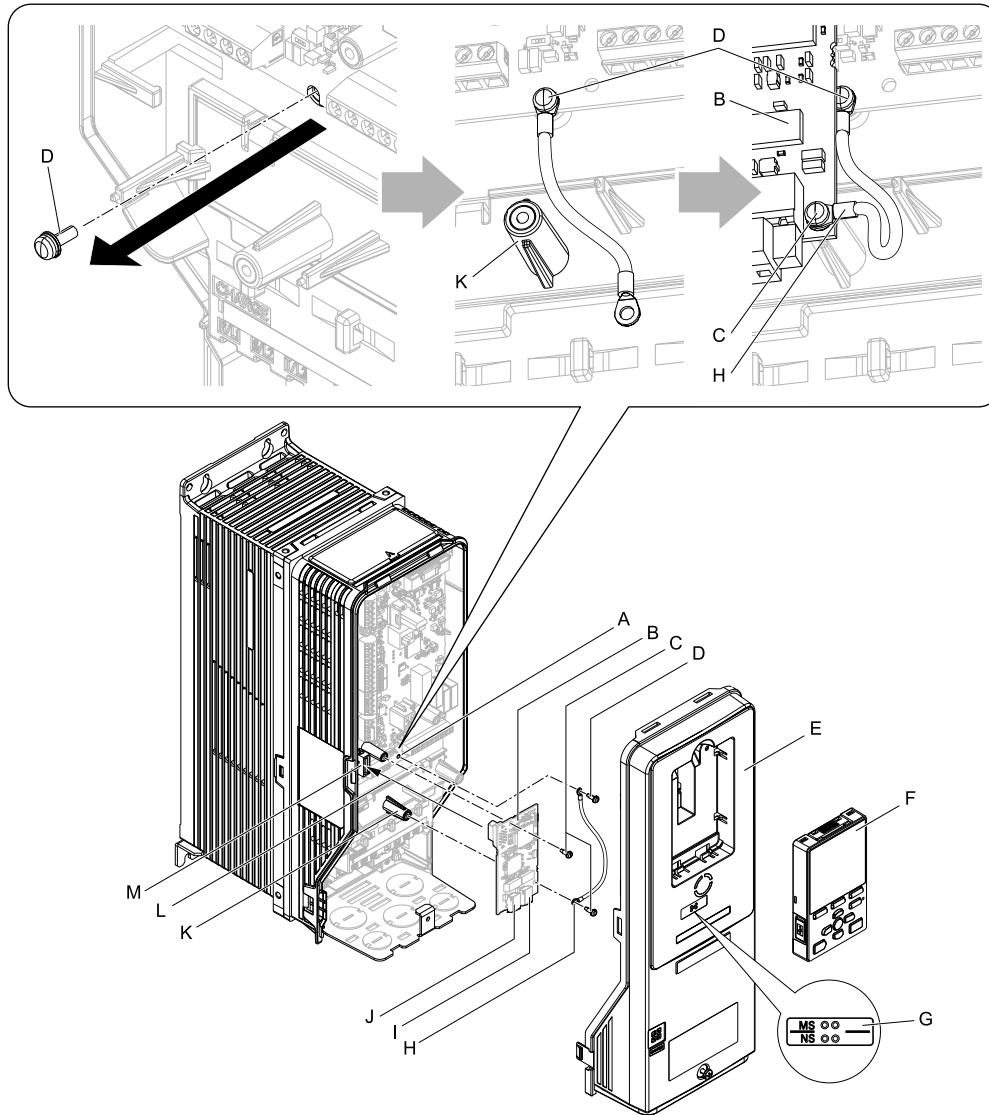

- A - Drive grounding terminal (FE)
- B - Option
- C - Included screws
- D - Ground screw
- E - Drive front cover
- F - Keypad
- G - LED label

- H - Ground wire
- I - Option modular connector CN1B (Port 2) (RJ45)
- J - Option modular connector CN1A (Port 1) (RJ45)
- K - Stud
- L - Insertion point for CN5 connector (HV600: CN5, FP605: CN5-A)
- M - Connector CN5 (HV600: CN5, FP605: CN5-A)

Figure 5.7 Drive Components with Option

Install the Option

⚠ DANGER *Electrical Shock Hazard. Do not examine, connect, or disconnect wiring on an energized drive. Before servicing, disconnect all power to the equipment and wait for the time specified on the warning label at a minimum. The internal capacitor stays charged after the drive is de-energized. The charge indicator LED extinguishes when the DC bus voltage decreases below 50 Vdc. When all indicators are OFF, measure for dangerous voltages to make sure that the drive is safe. If you do work on the drive when it is energized, it will cause serious injury or death from electrical shock.*

NOTICE *Damage to Equipment. When you touch the option, make sure that you observe correct electrostatic discharge (ESD) procedures. If you do not follow procedures, it can cause ESD damage to the drive circuitry.*

1. Shut off power to the drive and wait for the time specified on the drive warning label at a minimum. Make sure that the charge indicator LED is unlit, then remove the keypad and front cover. Refer to the drive manuals for more information.
2. Remove the keypad (F) and front cover (E).
3. Put the LED label (G) in the correct position on the drive front cover (E).

4. Remove the screw (D) installed in the drive grounding terminal (A).
5. Use the screw (C) installed in the FE ground terminal of the drive (A) to connect one end of the included ground wire (H) to the ground terminal on the drive.
Route ground wire on the right side of the stud (K).
Tighten the screw to a correct tightening torque:
 - 0.5 N·m to 0.6 N·m (4.4 lbf·in to 5.3 lbf·in)
6. Install the option (B) into the CN5 connector (M) (HV600: CN5, FP605: CN5-A) on the drive and use one of the included screws (C) to put it in place.
Tighten the screw to a correct tightening torque:
 - 0.5 N·m to 0.6 N·m (4.4 lbf·in to 5.3 lbf·in)

Note:

Only two screws are necessary to install the option on HV600 and FP605 drives.

7. Use one of the remaining included screws (C) to connect the ground wire (H) to the ground terminal and installation hole on the option (B).
Refer to [Figure 5.7](#) for instruction about crimp terminal orientation and wire routing.
Tighten the screw to a correct tightening torque:
 - 0.5 N·m to 0.6 N·m (4.4 lbf·in to 5.3 lbf·in)
8. Firmly connect the Ethernet communication cables to CN1B (Port 2) (I), and/or CN1A (Port 1) (J).
Isolate communication cables from main circuit wiring and other electrical and power lines. Make sure that you firmly connect the cable end. Refer to [Communication Cable Specifications on page 19](#) for more information.
9. Reattach the drive front cover (E) and the keypad (F).
Refer to the drive manuals for more information.

NOTICE Do not pinch cables between the front covers and the drive. Failure to comply could cause erroneous operation.

10. Set drive parameters in [Related Drive Parameters on page 20](#) for correct option performance.

◆ Communication Cable Specifications

Yaskawa recommends using shielded Cat5e cable. The Yaskawa warranty does not cover other cable types.

■ Option Connection Diagram

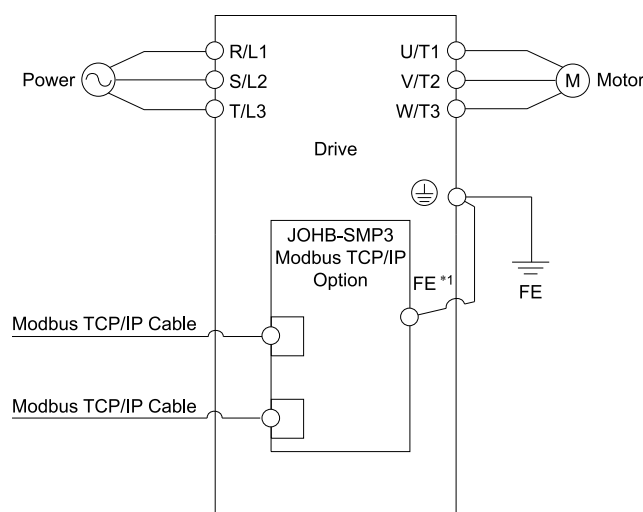

Figure 5.8 Option Connection Diagram

*1 Connect the specified ground wire for installations on 1000-series, GA500, HV600 and FP605 drives. The ground wire is not necessary for installation on GA700, GA800, or CR700 drives.

■ Communication Topology Specifications

Drives equipped with the JOHB-SMP3 option can be connected to network in either star or line topology.

- Star Topology
Use either one of the communication connectors CN1A (Port 1) or CN1B (Port 2).

• **Daisy-Chained Topology**

Use the communication connectors CN1A (Port 1) and CN1B (Port 2) at the same time. A switch is not necessary for this connection.

Note:

- This option does not support STP and RSTP.
- To use this option in a ring topology, prepare a separate device that supports STP and RSTP in the same network.
- If the link speed of Port 1 is different than the link speed of Port 2, it will trigger a PA1 [PLC Alarm 1] and the drive will not send data between the ports. To prevent this alarm, set F7-14 = 1 [Duplex Mode Selection = Auto/Auto (Auto Negotiation/Auto Negotiation)] and set the two connected nodes to the same link speed, set the two connected nodes to the same speed, and make sure that F7-15 ≠ 101 or 102 [Communication Speed Selection ≠ 10/100 Mbps (10 Mbps/100 Mbps) or 100/10 Mbps (100 Mbps/10 Mbps)].

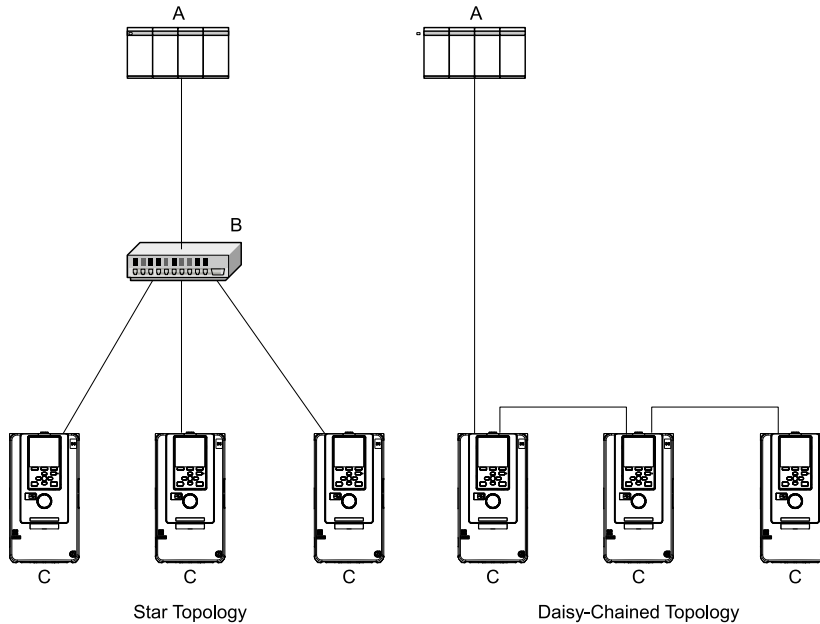

A - PLC
B - Switch

C - Drive

Figure 5.9 Communication Cable Wiring

6 Related Drive Parameters

These parameters set the drive for operation with the option. Make sure that the parameter settings in this table are correct before you start network communications.

Note:

- Hex.: MEMOBUS addresses that you can use to change parameters over network communication are represented in hexadecimal numbers.
- Expert: The parameter that is available in Expert Mode only. When A1-01 = 3 [Access Level Selection = Expert Level], Expert Mode parameters can be displayed on and set with the keypad.

No. (Hex.)	Name	Description	Default (Range)
b1-01 (0180)	Frequency Reference Selection 1	Selects the input method for frequency reference. 0 : Keypad 1 : Analog Input 2 : Memobus/Modbus Communications 3 : Option PCB 4 : Pulse Train Input Note: • Set b1-01 = 3 to use the master device to control the frequency reference of the drive. • The default setting is different for different drives. Refer to the instruction manual of your specific drive for more information.	1 (0 - 4)
b1-02 (0181)	Run Command Selection 1	Sets the input method for the Run command. 0 : Keypad 1 : Digital Input 2 : Memobus/Modbus Communications 3 : Option PCB 7 : AUTO Command + Term Run 8 : AUTO Command + Serial Run 9 : AUTO Command + Option Run	1 (0 - 9)

No. (Hex.)	Name	Description	Default (Range)
		<p>Note:</p> <ul style="list-style-type: none"> Set <i>b1-02</i> = 3 or 9 to start and stop the drive with the master device using serial communications. The setting range is different for different drives. Refer to the instruction manual of your specific drive for more information. 	
F6-01 (03A2)	Communication Error Selection	<p>Selects drive response when the drive detects a <i>bUS [Option Communication Error]</i> error during communications with the option.</p> <p>0 : Ramp to Stop 1 : Coast to Stop 2 : Fast Stop (Use C1-09) 3 : Alarm Only 4 : Alarm (Run at <i>d1-04</i>) 5 : Alarm - Ramp Stop</p> <p>Note:</p> <ul style="list-style-type: none"> When you set this parameter to 3 or 4, the drive will continue operation after it detects a fault. Separately prepare safety protection equipment and systems, for example fast-stop switches. Refer to the drive manual to know if settings 4 and 5 are available. The setting range for 1000-Series drives is different for different software versions. Refer to the Peripheral Devices & Options section of the drive instruction manual for more information. Changes to this parameter take effect immediately. It is not necessary to cycle power on the drive. 	1 (0 - 5)
F6-02 (03A3)	Comm External Fault (EF0) Detect	<p>Selects the conditions at which <i>EF0 [Option Card External Fault]</i> is detected.</p> <p>0 : Always Detected 1 : Detected during RUN Only</p>	0 (0, 1)
F6-03 (03A4)	Comm External Fault (EF0) Select	<p>Selects the operation of the drive when <i>EF0 [Option Card External Fault]</i> is detected.</p> <p>0 : Ramp to Stop 1 : Coast to Stop 2 : Fast Stop (Use C1-09) 3 : Alarm Only</p> <p>Note:</p> <p>When you set this parameter to 3, the drive will continue operation after it detects a fault. Separately prepare safety protection equipment and systems, for example fast stop switches.</p>	1 (0 - 3)
F6-06 (03A7)	Torque Reference/Limit by Comm	<p>Selects whether to enable or disable the torque reference and torque limit received from the communication option.</p> <p>0 : Disabled 1 : Enabled</p> <p>Note:</p> <ul style="list-style-type: none"> Control method availability of this parameter is different for different product series. <ul style="list-style-type: none"> –1000-Series Parameter is available when <i>A1-02</i> = 3, 6, 7 [<i>Control Method Selection</i> = Closed Loop Vector, PM Advanced Open Loop Vector, PM Closed Loop Vector]. When you enable this parameter, <i>d5-01 [Torque Control Selection]</i> sets the drive to read the value as the Torque Limit value or the Torque Reference value. <i>d5-01</i> = 0 [<i>Speed Control</i>]: Torque Limit <i>d5-01</i> = 1 [<i>Torque Control</i>]: Torque Reference When <i>A1-02</i> = 6 [<i>Control Method Selection</i> = PM Advanced Open Loop Vector], the drive reads this value as the Torque Limit. –GA500 Parameter is available when <i>A1-02</i> = 2, 6, 8 [<i>Control Method Selection</i> = Open Loop Vector PM Advanced Open Loop Vector, EZ Vector Control]. The drive reads this value as the Torque Limit. –GA700, GA800 Parameter is available when <i>A1-02</i> = 2, 3, 4, 6, 7, 8 [<i>Control Method Selection</i> = Open Loop Vector, Closed Loop Vector, Advanced Open Loop Vector, PM Advanced Open Loop Vector, PM Closed Loop Vector, EZ Vector Control]. When you enable this parameter, <i>d5-01 [Torque Control Selection]</i> sets the drive to read the value as the Torque Limit value or the Torque Reference value. <i>d5-01</i> = 0 [<i>Speed Control</i>]: Torque Limit <i>d5-01</i> = 1 [<i>Torque Control</i>]: Torque Reference When <i>A1-02</i> = 2, 8 [<i>Control Method Selection</i> = Open Loop Vector, EZ Vector Control], the drive reads this value as the Torque Limit. –CR700 Parameter is available when <i>A1-02</i> = 2, 3, 4 [<i>Control Method Selection</i> = Open Loop Vector, Closed Loop Vector, Advanced Open Loop Vector]. –HV600, FP605 Torque Limit is enabled when <i>A1-02</i> = 8 [<i>Control Method Selection</i> = EZ Vector Control]. If the PLC does not supply a torque reference or torque limit when <i>F6-06</i> = 1 [<i>Torque Reference/Limit by Comm</i> = Enabled], the motor cannot rotate. 	0 (0, 1)
F6-07 (03A8)	Multi-Step Ref @ NetRef/ComRef	<p>0 : Disable Multi-Step References 1 : Enable Multi-Step References</p> <p>Note:</p> <p>Default setting of <i>F6-07</i> is 1 for GA500.</p>	0 (0, 1)
F6-08 (036A)	Comm Parameter Reset @Initialize	<p>Selects whether communication-related parameters <i>F6-xx</i> and <i>F7-xx</i> are set back to original default values when you use parameter <i>A1-03 [Initialize Parameters]</i> to initialize the drive.</p> <p>0 : No Reset - Parameters Retained 1 : Reset - Back to Factory Default</p>	0 (0, 1)

6 Related Drive Parameters

No. (Hex.)	Name	Description	Default (Range)
		<p>Note: When you set <i>F6-08</i> to 1 and you then use <i>A1-03</i> to initialize the drive, the drive will not change this setting value.</p>	
F6-14 (03BB)	Bus Error Auto Reset	<p>Enables and disables the automatic reset of a <i>bUS [Option Communication Error]</i> fault.</p> <p>0 : Disabled 1 : Enabled</p> <p>Note:</p> <ul style="list-style-type: none"> This parameter is not available in all 1000-series drives. Changes to this parameter take effect immediately. It is not necessary to cycle power on the drive. 	0 (0, 1)
F6-15 (0B5B)	Comm. Option Parameters Reload	<p>Sets when the drive will activate the <i>F6-xx/F7-xx</i> communications-related parameters that you changed. Use this parameter as an alternative to cycling power to the drive to active parameters.</p> <p>0 : Reload at Next Power Cycle 1 : Reload Now 2 : Cancel Reload Request</p> <p>Note:</p> <ul style="list-style-type: none"> <i>F6-15</i> is reset to 0 after setting 1 or 2. This parameter is not available in all 1000-series drives. Changes to this parameter take effect immediately. It is not necessary to cycle power on the drive. 	0 (0 - 2)
F7-01 (03E5)	IP Address 1	<p>Sets the static/fixed IP address. Sets the most significant octet.</p> <p>Note:</p> <ul style="list-style-type: none"> This parameter is only effective when <i>F7-13</i> = 0 [<i>Address Mode at Startup = Static</i>]. All IP Addresses must be unique. You must cycle power to the drive for the changes to take effect. For non-1000 series drives, you can set <i>F6-15</i> = 1 [<i>Comm. Option Parameters Reload = Reload Now</i>]. 	192 (0 - 255)
F7-02 (03E6)	IP Address 2	<p>Sets the static/fixed IP address. Sets the second most significant octet.</p> <p>Note:</p> <ul style="list-style-type: none"> This parameter is only effective when <i>F7-13</i> = 0 [<i>Address Mode at Startup = Static</i>]. All IP Addresses must be unique. You must cycle power to the drive for the changes to take effect. For non-1000 series drives, you can set <i>F6-15</i> = 1 [<i>Comm. Option Parameters Reload = Reload Now</i>]. 	168 (0 - 255)
F7-03 (03E7)	IP Address 3	<p>Sets the static/fixed IP address. Sets the third most significant octet.</p> <p>Note:</p> <ul style="list-style-type: none"> This parameter is only effective when <i>F7-13</i> = 0 [<i>Address Mode at Startup = Static</i>]. All IP Addresses must be unique. You must cycle power to the drive for the changes to take effect. For non-1000 series drives, you can set <i>F6-15</i> = 1 [<i>Comm. Option Parameters Reload = Reload Now</i>]. 	1 (0 - 255)
F7-04 (03E8)	IP Address 4	<p>Sets the static/fixed IP address. Sets the fourth most significant octet.</p> <p>Note:</p> <ul style="list-style-type: none"> This parameter is only effective when <i>F7-13</i> = 0 [<i>Address Mode at Startup = Static</i>]. All IP Addresses must be unique. You must cycle power to the drive for the changes to take effect. For non-1000 series drives, you can set <i>F6-15</i> = 1 [<i>Comm. Option Parameters Reload = Reload Now</i>]. 	20 (0 - 255)
F7-05 (03E9)	Subnet Mask 1	<p>Sets the static/fixed Subnet Mask. Sets the most significant octet.</p> <p>Note:</p> <ul style="list-style-type: none"> This parameter is only effective when <i>F7-13</i> = 0 [<i>Address Mode at Startup = Static</i>]. All IP Addresses must be unique. You must cycle power to the drive for the changes to take effect. For non-1000 series drives, you can set <i>F6-15</i> = 1 [<i>Comm. Option Parameters Reload = Reload Now</i>]. 	255 (0 - 255)
F7-06 (03EA)	Subnet Mask 2	<p>Sets the static/fixed Subnet Mask. Sets the second most significant octet.</p> <p>Note:</p> <ul style="list-style-type: none"> This parameter is only effective when <i>F7-13</i> = 0 [<i>Address Mode at Startup = Static</i>]. All IP Addresses must be unique. You must cycle power to the drive for the changes to take effect. For non-1000 series drives, you can set <i>F6-15</i> = 1 [<i>Comm. Option Parameters Reload = Reload Now</i>]. 	255 (0 - 255)
F7-07 (03EB)	Subnet Mask 3	<p>Sets the static/fixed Subnet Mask. Sets the third most significant octet.</p> <p>Note:</p> <ul style="list-style-type: none"> This parameter is only effective when <i>F7-13</i> = 0 [<i>Address Mode at Startup = Static</i>]. All IP Addresses must be unique. You must cycle power to the drive for the changes to take effect. For non-1000 series drives, you can set <i>F6-15</i> = 1 [<i>Comm. Option Parameters Reload = Reload Now</i>]. 	255 (0 - 255)
F7-08 (03EC)	Subnet Mask 4	<p>Sets the static/fixed Subnet Mask. Parameter <i>F7-08</i> sets the fourth most significant octet.</p> <p>Note:</p> <ul style="list-style-type: none"> This parameter is only effective when <i>F7-13</i> = 0 [<i>Address Mode at Startup = Static</i>]. All IP Addresses must be unique. You must cycle power to the drive for the changes to take effect. For non-1000 series drives, you can set <i>F6-15</i> = 1 [<i>Comm. Option Parameters Reload = Reload Now</i>]. 	0 (0 - 255)
F7-09 (03ED)	Gateway Address 1	<p>Sets the static/fixed Gateway address. Sets the most significant octet.</p> <p>Note:</p> <ul style="list-style-type: none"> This parameter is only effective when <i>F7-13</i> = 0 [<i>Address Mode at Startup = Static</i>]. All IP Addresses must be unique. 	192 (0 - 255)

No. (Hex.)	Name	Description	Default (Range)
		<ul style="list-style-type: none"> You must cycle power to the drive for the changes to take effect. For non-1000 series drives, you can set $F6-15 = 1$ [Comm. Option Parameters Reload = Reload Now]. 	
F7-10 (03EE)	Gateway Address 2	<p>Sets the static/fixed Gateway address. Sets the second most significant octet.</p> <p>Note:</p> <ul style="list-style-type: none"> This parameter is only effective when $F7-13 = 0$ [Address Mode at Startup = Static]. All IP Addresses must be unique. You must cycle power to the drive for the changes to take effect. For non-1000 series drives, you can set $F6-15 = 1$ [Comm. Option Parameters Reload = Reload Now]. 	168 (0 - 255)
F7-11 (03EF)	Gateway Address 3	<p>Sets the static/fixed Gateway address. Sets the third most significant octet.</p> <p>Note:</p> <ul style="list-style-type: none"> This parameter is only effective when $F7-13 = 0$ [Address Mode at Startup = Static]. All IP Addresses must be unique. You must cycle power to the drive for the changes to take effect. For non-1000 series drives, you can set $F6-15 = 1$ [Comm. Option Parameters Reload = Reload Now]. 	1 (0 - 255)
F7-12 (03F0)	Gateway Address 4	<p>Sets the static/fixed Gateway address. Parameter F7-12 sets the fourth most significant octet.</p> <p>Note:</p> <ul style="list-style-type: none"> This parameter is only effective when $F7-13 = 0$ [Address Mode at Startup = Static]. All IP Addresses must be unique. You must cycle power to the drive for the changes to take effect. For non-1000 series drives, you can set $F6-15 = 1$ [Comm. Option Parameters Reload = Reload Now]. 	1 (0 - 255)
F7-13 (03F1)	Address Startup Mode	<p>Selects how the option address is set.</p> <p>0 : Static (Use F7-01 to F7-12 to set.) 1 : BOOTP (Use network address.) 2 : DHCP (Use network address.)</p> <p>Note:</p> <p>You must cycle power to the drive for the changes to take effect. For non-1000 series drives, you can set $F6-15 = 1$ [Comm. Option Parameters Reload = Reload Now].</p>	2 (0 - 2)
F7-14 (03F2)	Duplex Mode Selection	<p>Sets duplex mode settings (Port 1 (CN1A)/Port 2 (CN1B)).</p> <p>0 : Half/Half (Half Duplex/Half Duplex) 1 : Auto/Auto (Auto Negotiation/Auto Negotiation) 2 : Full/Full (Full Duplex/Full Duplex) 3 : Half/Auto (Half Duplex/Auto Negotiation) 4 : Half/Full (Half Duplex/Full Duplex) 5 : Auto/Half (Auto Negotiation/Half Duplex) 6 : Auto/Full (Auto Negotiation/Full Duplex) 7 : Full/Half (Full Duplex/Half Duplex) 8 : Full/Auto (Full Duplex/Auto Negotiation)</p> <p>Note:</p> <p>You must cycle power to the drive for the changes to take effect. For non-1000 series drives, you can set $F6-15 = 1$ [Comm. Option Parameters Reload = Reload Now].</p>	1 (0 - 8)
F7-15 (03F3)	Communication Speed Selection	<p>Sets the communications speed (Port 1 (CN1A)/Port 2 (CN1B)).</p> <p>10 : 10/10 Mbps (10 Mbps/10 Mbps) 100 : 100/100 Mbps (100 Mbps/100 Mbps) 101 : [Not Used/No function] 10/100 Mbps (10 Mbps/100 Mbps) 102 : [Not Used/No function] 100/10 Mbps (100 Mbps/10 Mbps)</p> <p>Note:</p> <ul style="list-style-type: none"> $F7-15$ is only effective when the port is set to half or full duplex in $F7-14$ [Duplex Mode Selection]. You must cycle power to the drive for the changes to take effect. For non-1000 series drives, you can set $F6-15 = 1$ [Comm. Option Parameters Reload = Reload Now]. 	10 (10 - 102)
F7-16 (03F4)	Timeout Value	<p>Sets the detection time for a communications timeout.</p> <p>Note:</p> <ul style="list-style-type: none"> Set this parameter to 0.0 to disable the connection timeout function. This parameter is not available in all 1000-series drives. Changes to this parameter take effect immediately. It is not necessary to cycle power on the drive. 	0.0 s (0.0 s - 30.0 s)
H5-11 (043C)	Communications ENTER Function Selection (Function common to communication option)	<p>Sets when an Enter command is necessary to use MEMOBUS/Modbus communications to change parameter values.</p> <p>0 : Parameter changes are activated when ENTER command is written 1 : Parameter changes are activated immediately. No ENTER command is necessary.</p>	0 (0, 1)

Table 6.1 Option Monitor

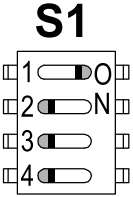
No.	Name	Description	Range
U4-75	Communication OPT Protocol	<p>Shows the setting of the DIP switch S1.</p> <ul style="list-style-type: none"> 70 = All switches OFF (incorrect for Modbus TCP/IP) 71 = Switch 1 ON, all others OFF (correct for Modbus TCP/IP)  <p style="text-align: center;">S1</p> <ul style="list-style-type: none"> 72 to 7F = Other switch positions that are incorrect for Modbus TCP/IP <p>Note: Setting value is shown only when you use the drive with the latest software version. Contact Yaskawa or your nearest sales representative for more information.</p>	00 - FF (Hex.)
U4-76 - U4-78	MAC Address 1	<p>Shows the main MAC Address.</p> <ul style="list-style-type: none"> U4-76: First octet, Second octet U4-77: Third octet, Fourth octet U4-78: Fifth octet, Sixth octet <p>Note: Setting value is shown only when you use the drive with the latest software version. Contact Yaskawa or your nearest sales representative for more information.</p>	0000 - FFFF (Hex.)
U4-79 - U4-81 Expert	MAC Address 2	<p>Shows the second MAC Address.</p> <ul style="list-style-type: none"> U4-79: First octet, Second octet U4-80: Third octet, Fourth octet U4-81: Fifth octet, Sixth octet <p>Note: Setting value is shown only when you use the drive with the latest software version. Contact Yaskawa or your nearest sales representative for more information.</p>	0000 - FFFF (Hex.)
U4-82 - U4-84 Expert	MAC Address 3	<p>Shows the third MAC Address.</p> <ul style="list-style-type: none"> U4-82: First octet, Second octet U4-83: Third octet, Fourth octet U4-84: Fifth octet, Sixth octet <p>Note: Setting value is shown only when you use the drive with the latest software version. Contact Yaskawa or your nearest sales representative for more information.</p>	0000 - FFFF (Hex.)
U6-80 - U6-83	OPT IP Address 1 - 4	<p>Shows the currently available local IP Address.</p> <ul style="list-style-type: none"> U6-80: First octet U6-81: Second octet U6-82: Third octet U6-83: Fourth octet 	0 - 255
U6-84 - U6-87	Online Subnet 1 - 4	<p>Shows the currently available subnet mask.</p> <ul style="list-style-type: none"> U6-84: First octet U6-85: Second octet U6-86: Third octet U6-87: Fourth octet 	0 - 255
U6-88 - U6-91	Online Gateway 1 - 4	<p>Shows the currently available gateway address.</p> <ul style="list-style-type: none"> U6-88: First octet U6-89: Second octet U6-90: Third octet U6-91: Fourth octet 	0 - 255
U6-92	Online Speed	Shows CN1A Port 1 link speed currently available.	10: 10 Mbps 100: 100 Mbps
U6-93	Online Duplex	Shows CN1A Port 1 duplex setting currently available.	0: Half/Half 1: Full/Full
U6-94	OPT SPARE 1	Shows CN1B Port 2 link speed currently available.	10: 10 Mbps 100: 100 Mbps
U6-95	OPT SPARE 2	Shows CN1B Port 2 duplex setting currently available.	0: Half/Half 1: Full/Full
U6-97	OPT SPARE 4	Shows option software version.	-
U6-98	First Fault	Shows first option fault.	-
U6-99	Current Fault	Shows current option fault.	-

7 Modbus TCP/IP Messaging

◆ Modbus TCP/IP Overview

The Modbus TCP/IP protocol is essentially the Modbus protocol over an Modbus TCP/IP network. A master controller (typically a PLC) sends commands to slave devices, which then perform the specified functions and send a response to the master. The drive using the option has slave functionality.

■ Supported Modbus TCP/IP Commands

Table 7.1 Supported Modbus TCP/IP Commands

Function Code (Hex.)	Name
03	Read Multiple Registers
06	Write Single Register
10	Write Multiple Registers
17	Read/Write Multiple Registers

■ Drive Modbus TCP/IP Option Registers

All of the command registers, monitor registers, and parameters documented in the drive Technical Manual are accessible via the option.

■ High Speed Access Drive Modbus TCP/IP Option Registers

Many of the registers required for control have been specially mapped to provide higher speed access to increase network performance. Use these registers for the best response times.

Table 7.2 and Table 7.3 show all data that are refreshed in a fast cycle. Command registers can be read from and written into.

Note:

Set bits that you do not use to 0. Do not write to reserved registers.

Table 7.2 Command Register Data

Register Number (Hex.)	Description	
0000	Reserved	
0001	Operation Commands and Multi-function Inputs	
	bit0	<i>H5-12 = 0 [Run Command Method Selection = FWD/Stop, REV/Stop]: FWD/Stop</i> 1: Forward Run 0: Stop <i>H5-12 = 1 [Run Command Method Selection = Run/Stop, FWD/REV]: Run/Stop</i> 1: Run 0: Stop
	bit1	<i>H5-12 = 0 [Run Command Method Selection = FWD/Stop, REV/Stop]: REV/Stop</i> 1: Reverse run 0: Stop <i>H5-12 = 1 [Run Command Method Selection = Run/Stop, FWD/REV]: FWD/REV</i> 1: Reverse run 0: Forward run
	bit2	External Fault (EF0 [Option Card External Fault])
	bit3	Fault Reset
	bit4	Multi-Function Input 1
	bit5	Multi-Function Input 2
	bit6	Multi-Function Input 3
	bit7	Multi-Function Input 4
	bit8	Multi-Function Input 5
	bit9	Multi-Function Input 6
	bit A	Multi-Function Input 7

7 Modbus TCP/IP Messaging

Register Number (Hex.)	Description	
	bit B	Multi-Function Input 8
	bit C - F	Reserved
0002	Frequency Reference	Units are determined by parameter <i>o1-03 [Frequency Display Unit Selection]</i> .
0003	Output voltage gain Unit: 0.1% Setting range: 20 (2.0%) - 2000 (200.0%) Default value at energize: 1000 (100.0%)	
0004	Torque reference/torque limit (0.1% signed)	
0005	Torque compensation (0.1% signed)	
0006	PID setpoint (0.01% signed)	
0007	Multi-Function Analog Output Terminal 1 Setting (10 V/4000 (Hex.))	
0008	Multi-Function Analog Output Terminal 2 Setting (10 V/4000 (Hex.))	
0009	MFDO setting	
	bit 0	Multi-Function Contact Output 1 Terminal M1-M2 (varies by drive model)
	bit 1	Multi-Function Contact Output 2 Terminal M3-M4 (varies by drive model)
	bit 2	Multi-Function Contact Output 3 Terminal M5-M6 (varies by drive model)
	bit 3- 5	Reserved
	bit 6	Enables the function in bit 7
	bit 7	Fault Relay Output Terminal MA/ MB- MC (varies by drive model)
	bit 8 - F	Reserved
000A	Pulse train output (Units: 1/1 Hz, setting range: 0 - 32000)	
000B - 000E	Reserved	
000F	Command selection setting	
	bit 0	Reserved
	bit 1	Input for the PID setpoint
	bit 2	Torque reference/torque limit input (enables the setting from MEMOBUS/Modbus)
	bit 3	Torque compensation input (enables the setting from MEMOBUS/Modbus)
	bit 4 - B	Reserved
	bit C	Terminal S5 input of broadcast message
	bit D	Terminal S6 input of broadcast message
	bit E	Terminal S7 input of broadcast message
bit F	Terminal S8 input of broadcast message	
0010 - 001A	Reserved	
001B	Analog Monitor Option AO-A3 Analog Output 1 (10 V/4000 (Hex.))	
001C	Analog Monitor Option AO-A3 Analog Output 2 (10 V/4000 (Hex.))	
001D	Digital output option DO-A3 output value (binary)	
001E - 001F	Reserved	

Table 7.3 Drive Registers

No. (Modbus Register)	Drive Registers	Register Name	Bit	Description
2000	4B	Drive Status (U1-12)	0	1: During Run
			1	1: During zero speed
			2	1: During reverse
			3	1: During reset signal input
			4	1: During Speed Agree

No. (Modbus Register)	Drive Registers	Register Name	Bit	Description
			5	1: Drive operation ready
			6	1: Alarm
			7	1: Fault
			8	1: During Operation Error (oPExx)
			9	1: Momentary power loss recovery 0: Power loss recovery
			A	1: Motor 2 Selection
			B	Reserved
			C	Reserved
			D	Reserved
			E	ComRef status/ NetRef status
			F	ComCtrl status/ NetCtrl status
2001	44	Motor Speed Monitor (U1-05)		
2002	48	Torque Reference Monitor (U1-09)		
2003	F0	PG Count Channel 1		
2004	40	Frequency Reference Monitor (U1-01)		
2005	41	Output Frequency Monitor (U1-02)		
2006	26	Output Current (U1-03) (units: 0.1 A)		
2007	4F	Terminal A2 Input Level Monitor (U1-14)		
2008	46	DC Bus Voltage Monitor (U1-07)		
2009	C0	Error Signal 1	0	Reserved
			1	Undervoltage (Uv1)
			2	Control Power Supply Undervoltage (Uv2)
			3	Soft Charge Circuit Fault (Uv3)
			4	Short Circuit/IGBT Failure (SC)
			5	Ground Fault (GF)
			6	Overcurrent (oC)
			7	Overvoltage (ov)
			8	Heatsink Overheat (oH)
			9	Heatsink Overheat (oH1)
			A	Motor Overload (oL1)
			B	Drive Overload (oL2)
			C	Overtorque Detection 1 (oL3)
			D	Overtorque Detection 2 (oL4)
			E	Dynamic Braking Transistor Fault (rr)
F	Braking Resistor Overheat (rH)			
200A	C1	Error Signal 2	0	External Fault (Terminal S3) (EF3)
			1	External Fault (Terminal S4) (EF4)
			2	External Fault (Terminal S5) (EF5)
			3	External Fault (Terminal S6) (EF6)
			4	External Fault (Terminal S7) (EF7)
			5	External Fault (Terminal S8) (EF8)
			6	Cooling fan Error (FAn)
			7	Overspeed (oS)
			8	Excessive Speed Deviation (dEv)
			9	PG Disconnected (PGo)

No. (Modbus Register)	Drive Registers	Register Name	Bit	Description
			A	Input Phase Loss (PF)
			B	Output Phase Loss (LF)
			C	Motor Overheat (PTC input) (oH3)
			D	Digital Operator Connection Fault (oPr)
			E	EEPROM Write Error (Err)
			F	Motor Overheat Fault (PTC input) (oH4)
200B	C2	Error Signal 3	0	MEMOBUS/Modbus Communication Error (CE)
			1	Option Communication Error (bUS)
			2	Reserved
			3	Reserved
			4	Control Fault (CF)
			5	Zero Servo Fault (SvE)
			6	Option External Fault (EF0)
			7	PID Feedback Loss (FbL)
			8	Undertorque Detection 1 (UL3)
			9	Undertorque Detection 2 (UL4)
			A	High Slip Braking Overload (oL7)
			B	Reserved
			C	Reserved
			D	Reserved
			E	Reserved
			F	Hardware Fault (includes oFx)
200C	4E	Terminal A1 Input Level Monitor (U1-13)		
200D	49	Digital Input Terminal Status (U1-10)		
200E	50	Terminal A3 Input Level Monitor (U1-15)		
200F	F1	PG Count Channel 2		
2010	4D	Drive Software Number (Flash) (U1-25)		

■ Types of Enter Commands

The drive supports the two Enter commands shown in Table 7.4.

An Enter command is enabled by writing 0 to register number 0900 (Hex.) or 0910 (Hex.).

These registers can be written to only.

An error will occur if the user attempts to read from these registers.

Table 7.4 Types of Enter Commands

Register Number (Hex.)	Description
0900	When you write parameter data to the EEPROM, you will enable the data on the RAM at the same time. Parameter changes remain even if the power supply is cycled.
0910	This updates the data on the RAM, but does not write data to the EEPROM. Parameter changes are lost when the drive is shut off.

Note:

- You can write the EEPROM to the drive a maximum of 100,000 times. Do not frequently execute the Enter command (0900 (Hex.)) that is written to EEPROM. When the command data or broadcast message is transmitted to the drive, the Enter command is not necessary.
- Parameter data cannot be written to EEPROM during undervoltage, even using 0900 (Hex.).
- If undervoltage occurs when a making several parameter changes issued with a single ENTER command, the writing process may be aborted before all of the new changes have been written. Because all of the data has not yet been written, the EEPROM data error CPF06 will be displayed the next time power to the drive is cycled. To prevent CPF06, wait approximately 5 seconds after issuing the ENTER command before shutting off drive power.

■ Enter Command Function Differences Depending on the Setting of H5-11

Table 7.5 Enter Command Function Differences Depending on the Setting of H5-11

Function	H5-11 = 0	H5-11 = 1
Time when the parameter settings are enabled	When the drive receives the Enter command from the master	When you change the parameter settings
Upper and lower limit check	Checks the upper and lower limits and considers the related parameter settings.	Checks the upper and lower limit of the changed parameter only.
Default setting of related parameters	Not affected. The settings of related parameters remain unchanged. They must be changed manually, if needed.	Automatically changes the default settings for the related parameters.
Fault detection when you set more than one parameter	Accepts and responds as usual to correct setting data if the data contains parameter setting errors. The drive discards the disabled setting data, but will not return an error message.	Error occurs if only one setting is invalid. The drive discards the data that was sent.

■ Message Format

The data section of the Modbus packet contains the Modbus message. In this data section, the master sends commands to the slave, and the slave responds. The message format is configured for both sending and receiving as shown below, and the length of data packets depends on the command (function) content.

- Unit Identifier
- Function code
- Data

Unit Identifier

This field is used for intra-system routing purposes. It is typically used to communicate to a Modbus+ or a Modbus serial line slave through a gateway between a Modbus TCP/IP network and a Modbus serial line. This field is set by the Modbus master in the command and must be returned with the same value in the response by the slave. This is sometimes referred to as the Unit ID. This field is not usually used because the drive with the option does not have a gateway function. Refer to the manual of the master or gateway used when you set the value to the Unit identifier.

Function code

When sent by the master, this field identifies the command to be undertaken by the slave. It also identifies the format for the DATA section of the message. The slave normally echoes this command back to the master in its response message. When the most significant bit of this field is set in the response message, it signals an error condition has occurred.

Data

This field contains multiple bytes of varying length based upon the Function Code for commands and based upon the results of the command in the response. When sent by the master, this field contains details of the command that the slave will require to carry out the function. When sent by the slave, this field contains details of the response and sometimes error information.

■ Modbus TCP/IP Option Function Details

03 (03 (Hex.)) Read Multiple Registers

This function code is used to read the contents of a contiguous block of registers. The command specifies the starting register and the number of registers. The normal response packs two bytes per register. For each register in the response, the first byte contains the most significant bits and the second byte contains the least significant bits.

Table 7.6 Read Multiple Registers (Command)

Description	Byte No.	Data (Hex.)
Slave Address (Unit Identifier)	1	00 - FF
Function Code	1	03
Starting Register	2	0000 - FFFF
Quantity of Registers	2	N */

*1 N = Quantity of Registers (1 to 16)

Table 7.7 Read Multiple Registers (Response)

Description	Byte No.	Data (Hex.)
Slave Address (Unit Identifier)	1	00 - FF
Function Code	1	03
Number of Data Bytes	1	2 × N ^{*1}
Register Values	N ^{*1} × 2	Values contained in slave registers

*1 N = Quantity of Registers

Table 7.8 Read Multiple Registers (Error Response)

Description	Byte No.	Data (Hex.)
Slave Address (Unit Identifier)	1	00 - FF
Error Code	1	83
Exception Code	1	Refer to Modbus TCP/IP Exception Codes.

Examples of Fault Response, Read Response, and Read Multiple Registers Command

Table 7.9 lists command examples to 4 read register contents (register addresses 0020 (Hex.) to 0023 (Hex.)) from a drive with the slave address (unit identifier) 02 (Hex.).

Table 7.10 shows examples of responses indicating that multiple registers have been read successfully. The contents read from 0020 (Hex.) are 1770 (Hex.), 1770 (Hex.), 0109 (Hex.), and 0000 (Hex.).

Table 7.11 shows examples of an error response when reading multiple registers. The exception code is 02 (Hex.) (indicating a register number error).

Table 7.9 Example Read Multiple Registers Command

Description	Data (Hex.)	
Slave Address (Unit Identifier)	02	
Function Code	03	
Starting Register ^{*1}	Upper	00
	Lower	20
Quantity of Registers	Upper	00
	Lower	04

*1 This option is set up to use PLC based (holding) register addressing (base 1). The drive will automatically convert the register address to one more than the address sent over the network before it will respond.

When reading the starting register 0020 (Hex.) from the PLC:

1. The PLC sends out a command specifying the starting register 001F (Hex.) to the network.
2. The drive automatically convert the starting register 001F (Hex.) to 0020 (Hex.).
3. The drive responds the value of register address 0020 (Hex.) to the PLC.

Table 7.10 Example Read Multiple Registers Response

Description	Data (Hex.)	
Slave Address (Unit Identifier)	02	
Function Code	03	
Number of Data Bytes	08	
Starting Register	Upper	17
	Lower	70
Next Register	Upper	17
	Lower	70
Next Register	Upper	01
	Lower	09
Last Register	Upper	00
	Lower	00

Table 7.11 Example Read Multiple Registers Error Response

Description	Data (Hex.)
Slave Address (Unit Identifier)	02
Error Code	83
Exception Code	02

06 (06 (Hex.)) Write Single Register

This function code is used to write to a single register in the drive. The command specifies the address of the register to be written and the value to write. The normal response is an echo of the request, returned after the register contents have been written.

Table 7.12 Write Single Register Command

Description	Byte No.	Data (Hex.)
Slave Address (Unit Identifier)	1	00 - FF
Function Code	1	06
Register Address	2	0000 - FFFF
Register Values	2	0000 - FFFF

Table 7.13 Write Single Register Response

Description	Byte No.	Data (Hex.)
Slave Address (Unit Identifier)	1	00 - FF
Function Code	1	06
Register Address	2	0000 - FFFF
Register Values	2	0000 - FFFF

Table 7.14 Write Single Register Error Response

Description	Byte No.	Data (Hex.)
Slave Address (Unit Identifier)	1	00 - FF
Error Code	1	86
Exception Code	1	Refer to Modbus TCP/IP Exception Codes.

Examples of Register Write Command

[Table 7.15](#) lists command examples when writing register value 0003 (Hex.) to register address 0001 (Hex.) in a drive with the slave address (unit identifier) 01 (Hex.).

[Table 7.16](#) shows examples of responses indicating that the write command has been executed successfully. The command specifies the value and the register address to write to.

[Table 7.17](#) shows examples of an error response when writing to a register. The exception code is 21 (Hex.) (indicating an invalid value).

Table 7.15 Examples of Register Write Command

Description	Data (Hex.)	
Slave Address (Unit Identifier)	01	
Function Code	06	
Register Address ^{*1}	Upper	00
	Lower	01
Register Values	Upper	00
	Lower	03

*1 This option is set up to use PLC based (holding) register addressing (base 1). The drive will automatically convert the register address to one more than the address sent over the network before it will respond.

When writing the register address 0001 (Hex.) from the PLC:

1. The PLC sends out a command specifying the register address 0000 (Hex.) to the network.
2. The drive automatically convert the register address 0000 (Hex.) to 0001 (Hex.).
3. The drive responds the value of register address 0001 (Hex.) to the PLC.

Table 7.16 Example Write Single Register Response

Description		Data (Hex.)
Slave Address (Unit Identifier)		01
Function Code		06
Register Address	Upper	00
	Lower	01
Register Values	Upper	00
	Lower	03

Table 7.17 Example Write Single Register Error Response

Description	Data (Hex.)
Slave Address (Unit Identifier)	01
Error Code	86
Exception Code	21

16 (10 (Hex.)) Write Multiple Registers

This function code is used to write to a contiguous block of registers in the drive. The command specifies the starting register address, the number of registers, and the values to be written. The command packs two bytes per register. For each register in the command, the first byte contains the most significant bits, and the second byte contains the least significant bits. The normal response returns the function code, starting address, and quantity of registers written.

Table 7.18 Write Multiple Registers Command

Description	Byte No.	Data (Hex.)
Slave Address (Unit Identifier)	1	00 - FF
Function Code	1	10
Starting Register ^{*1}	2	0000 - FFFF
Quantity of Registers	2	N ^{*2}
Number of Data Bytes	1	N ^{*2} × 2
Register Values	N ^{*2} × 2	0000 - FFFF

*1 This option is set up to use PLC based (holding) register addressing (base 1). The drive will automatically convert the register address to one more than the address sent over the network before it will respond.

When writing the starting register 0258 (Hex.) from the PLC:

1. The PLC sends out a command specifying the starting register 0257 (Hex.) to the network.
2. The drive automatically convert the starting register 0257 (Hex.) to 0258 (Hex.).
3. The drive responds the value of register address 0258 (Hex.) to the PLC.

*2 N = Quantity of Registers (1 to 16)

Table 7.19 Write Multiple Registers Response

Description	Byte No.	Data (Hex.)
Slave Address (Unit Identifier)	1	00 - FF
Function Code	1	10
Starting Register	2	0000 - FFFF
Quantity of Registers	2	N ^{*1}

*1 N = Quantity of Registers

Table 7.20 Write Multiple Registers Error Response

Description	Byte No.	Data (Hex.)
Slave Address (Unit Identifier)	1	01
Error Code	1	90
Exception Code	1	Refer to Modbus TCP/IP Exception Codes.

Examples of Multiple Registers Write Command

Table 7.21 lists command examples when writing register values 0001 (Hex.) and 0258 (Hex.) to register addresses 0001 (Hex.) and 0002 (Hex.) in a drive with the slave address (unit identifier) 01 (Hex.).

Table 7.22 shows examples of responses indicating that the write command has been executed successfully. The command specifies the beginning of the register address and the number of registers.

Table 7.23 shows examples of an error response when writing to a register. The exception code is 02 (Hex.) (indicating a register number error).

Table 7.21 Examples of Multiple Registers Write Command

Description		Data (Hex.)
Slave Address (Unit Identifier)		01
Function Code		10
Starting Register <i>*1</i>	Upper	00
	Lower	01
Quantity of Registers	Upper	00
	Lower	02
Number of Data Bytes		04
First Register Data	Upper	00
	Lower	01
Next Register Data	Upper	02
	Lower	58

*1 This option is set up to use PLC based (holding) register addressing (base 1). The drive will automatically convert the register address to one more than the address sent over the network before it will respond.

When writing the starting register 0001 (Hex.) from the PLC:

1. The PLC sends out a command specifying the starting register 0000 (Hex.) to the network.
2. The drive automatically convert the starting register 0000 (Hex.) to 0001 (Hex.).
3. The drive responds the value of register address 0001 (Hex.) to the PLC.

Table 7.22 Example Write Multiple Registers Response

Description		Data (Hex.)
Slave Address (Unit Identifier)		01
Function Code		10
Starting Register	Upper	00
	Lower	01
Quantity of Registers	Upper	00
	Lower	02

Table 7.23 Example Write Multiple Registers Error Response

Description	Data (Hex.)
Slave Address (Unit Identifier)	01
Error Code	90
Exception Code	02

23 (17 (Hex.)) Read/Write Multiple Registers

This function code performs a combination of one read operation and one write operation in a single Modbus TCP/IP transaction. The write operation is performed before the read. The command specifies the starting read address, quantity of contiguous registers to read, starting write address, quantity of contiguous registers to write and the values to be written. The normal response contains the values of the registers that were read.

For both the address and the values, the first byte contains the most significant bits and the second byte contains the least significant bits.

Table 7.24 Read/Write Multiple Registers Command

Description	Byte No.	Data (Hex.)
Slave Address (Unit Identifier)	1	00 - FF
Function Code	1	17
Read Starting Register	2	0000 - FFFF
Quantity of Registers to Read	2	M <i>*1</i>

Description	Byte No.	Data (Hex.)
Write Starting Register	2	0000 - FFFF
Quantity of Registers to Write	2	N *2
Write Byte Count	1	N *2 × 2
Write Register Values	N *2 × 2	0000 - FFFF

*1 M = Quantity of Registers to Read (range is 1 - 16)

*2 N = Quantity of Registers to Write (range is 1 - 16)

Table 7.25 Read/Write Multiple Registers Response

Description	Byte No.	Data (Hex.)
Slave Address (Unit Identifier)	1	00 - FF
Function Code	1	17
Number of Data Bytes	1	M *1 × 2
Read Register Values	M *1 × 2	Values contained in slave registers

*1 M = Quantity of Registers

Table 7.26 Read/Write Multiple Registers Error Response

Description	Byte No.	Data (Hex.)
Slave Address (Unit Identifier)	1	00 - FF
Error Code	1	97
Exception Code	1	Refer to Modbus TCP/IP Exception Codes.

Read/Write Multiple Registers

Table 7.27 lists command examples when reading registers 0001 (Hex.) and 0002 (Hex.) and then writing register values 0103 (Hex.) and 0258 (Hex.) to register addresses 0102 (Hex.) and 0103 (Hex.) in a drive with the slave address (unit identifier) 01 (Hex.).

Table 7.28 shows examples of responses indicating that the read/write multiple registers command has been executed successfully. Read data 1 contains the value of register address 0001 (Hex.) (0001 (Hex.)). Read data 2 contains the value of the register address 0002 (Hex.) (0002 (Hex.)).

Table 7.29 shows examples of an error response when the command to read and write to multiple registers has failed. The exception code is 02 (Hex.) (indicating a register number error).

Table 7.27 Example Read/Write Multiple Registers Command

Description		Data (Hex.)
Slave Address (Unit Identifier)		01
Function Code		17
Read Starting Register	Upper	00
	Lower	01
Quantity of Registers to Read	Upper	00
	Lower	02
Write Starting Register	Upper	01
	Lower	02
Quantity of Registers to Write	Upper	00
	Lower	02
Write Byte Count		04
First Write Register Data	Upper	01
	Lower	03
Next Write Register Data	Upper	02
	Lower	58

Table 7.28 Example Read/Write Multiple Registers Response

Description		Data (Hex.)
Slave Address (Unit Identifier)		01
Function Code		17
Number of Data Bytes		04
Read Data 1	Upper	00
	Lower	01
Read Data 2	Upper	00
	Lower	02

Table 7.29 Example Read/Write Multiple Registers Error Response

Description	Data (Hex.)
Slave Address (Unit Identifier)	01
Error Code	97
Exception Code	02

■ Modbus TCP/IP Exception Codes

When an error occurs, remove the cause and restart communications. The response message will contain one of the Error Codes defined in [Table 7.30](#).

Table 7.30 Modbus TCP/IP Exception Codes

Error Code (Hex.)	Error Name and Cause
01	Function Code Error Attempted to set a function code from a PLC other than 03 (Hex.), 06 (Hex.), 10 (Hex.), and 17 (Hex.).
02	Register Number Error A register number specified in the command message does not exist.
03	Data Length Error <ul style="list-style-type: none"> Invalid command message quantity In a write message, the value for write byte count does not match twice the value of the stated quantity of registers to write.
21	Data Setting Error <ul style="list-style-type: none"> Control data or parameter write data is outside the allowable setting range. Attempted to write a contradictory parameter setting.
22	Write Mode Error <ul style="list-style-type: none"> Attempted to write while the drive was operating to a parameter that cannot be written to during run. During an EEPROM data error (<i>CPF06 [EEPROM Memory Data Error]</i>), the master attempted to write to a parameter other than <i>A1-00 [Language Selection]</i>, <i>A1-01 [Access Level Selection]</i>, <i>A1-02 [Control Method Selection]</i>, <i>A1-03 [Initialize Parameters]</i>, <i>A1-04 [Password]</i>, <i>A1-05 [Password Setting]</i>, <i>E1-03 [V/f Pattern Selection]</i>, or <i>o2-04 [Drive Model (KVA) Selection]</i>. Attempted to write to read-only data.
23	DC Bus Undervoltage Write Error <ul style="list-style-type: none"> Attempted to write from the master during a <i>Uv1 [DC Bus Undervoltage]</i>. Attempted to execute and Enter command during a <i>Uv1 [DC Bus Undervoltage]</i>.
24	Writing Error during Parameter Processing Master attempted writing to the drive while the drive was processing parameter data.
25	Writing into EEPROM Disabled Writing into EEPROM write is disabled, but EEPROM write was executed from the MEMOBUS/Modbus network. When this error occurs, the keypad shows a message and the drive continues operation.

■ Control Connection Timeout

The option has a safety feature that declares a fault if communications between the master and drive is lost after the master commanded the drive to run.

A controlled connection is defined as one in which a master commands the drive by writing to register 01 (Hex.). After this write, the option will begin a timer. The timer will be reset upon subsequent writes to register 01 (Hex.). If the timer exceeds the value programmed in drive parameter *F7-16 [Timeout Value]*, the option will declare a *bUS [Option Communication Error]* if the option has an active run command to the drive. A value of 0 in *F7-16* means that the timeout is disabled.

The drive reaction to a *bUS* is programmable through drive parameter *F6-01 [Communication Error Selection]*.

8 Web Interface

The option contains a series of web pages that let you use a standard web browser to view status and diagnostic information.

You can access the web page through a self-contained web server at port 80. Type the IP address of the option into a web browser to access the home page.

Example: "http://192.168.1.20"

If you do not know the IP address, use monitors *U6-80 to U6-83 [Option IP Address 1 to Option IP Address 4]* on the keypad to read the IP address of the option. Refer to [Table 6.1](#) for more information.

◆ Home Page

YASKAWA CIPR-GA80U2004
Modbus-TCP / JOHB-SMP3

Home Modbus-TCP Network Chart Login

Status Extended Status

Drive Status

Ready

RUN ZERO SPD REV RESET AT SPD READY ALARM FAULT

Drive Monitors		Digital Inputs		Digital Outputs	
Frequency Reference	0.00 Hz	<input type="checkbox"/> S1	<input type="checkbox"/> M1-M2		
Output Frequency	0.00 Hz	<input type="checkbox"/> S2	<input checked="" type="checkbox"/> M3-M4		
Motor Speed	0.00 Hz	<input type="checkbox"/> S3	<input type="checkbox"/> M5-M6		
Output Current	0.0 A	<input type="checkbox"/> S4			
DC Bus Voltage	326 VDC	<input type="checkbox"/> S5			
Torque Reference	0.0 %	<input type="checkbox"/> S6			
		<input type="checkbox"/> S7			
		<input type="checkbox"/> S8			

Analog Inputs	
A1	0.0 %
A2	0.0 %
A3	0.0 %

Drive		Option Card	
Model	GA800	Model	JOHB-SMP3
Full Model	CIPR-GA80U2004	Version	VST908200
Version	9011	Protocol	Modbus-TCP
Serial Number	1W19X32035xxxxx	Serial Number	J01067C5437xxxxx

©2020 Yaskawa America, Inc. All Rights Reserved - WEB 426 (R0) Update Time: 1 sec

Figure 8.1 Home Page View

◆ Modbus-TCP Page

YASKAWA CIPR-GA80U2004
Modbus-TCP / JOHB-SMP3

Home Modbus-TCP Network Chart Login

Modbus-TCP

Current Connections	0
Connection Delta Time (ms)	N/A

©2020 Yaskawa America, Inc. All Rights Reserved - WEB 426 (R0) Update Time: 1 sec

Figure 8.2 Modbus-TCP Page View

◆ Network Page

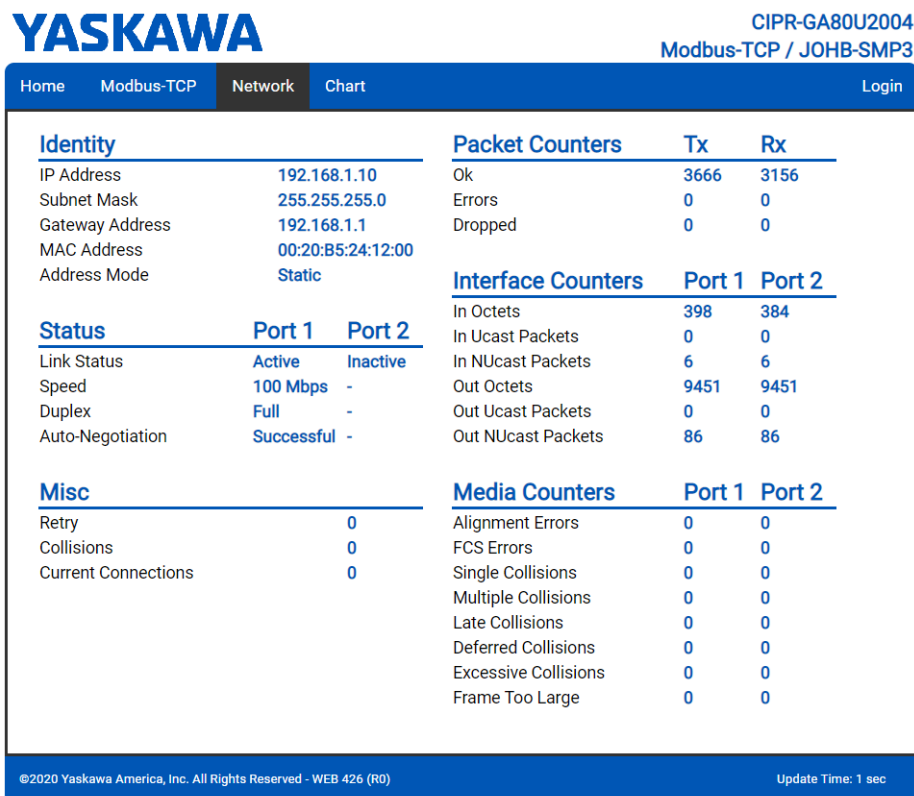

Figure 8.3 Network Page View

◆ Chart Page

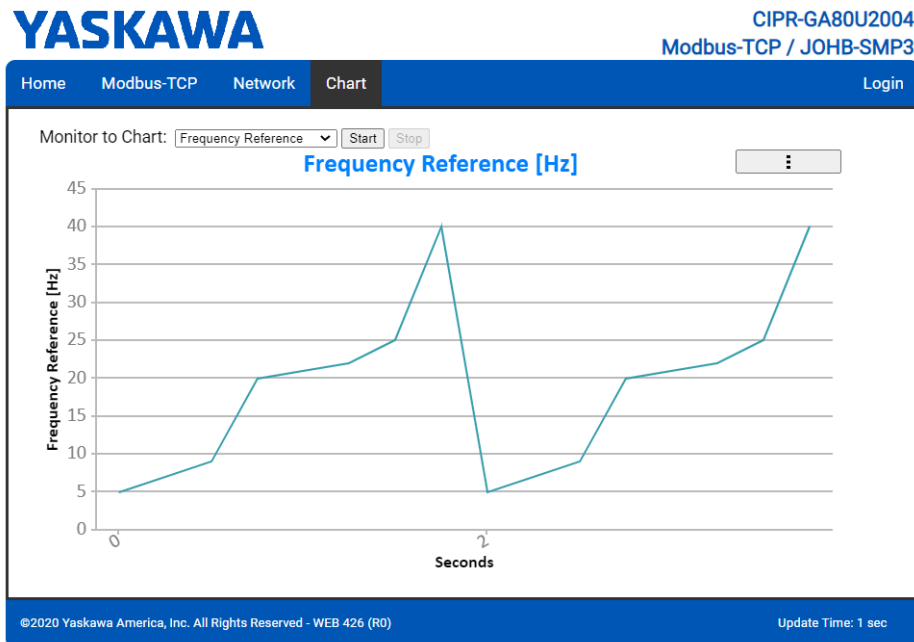

Figure 8.4 Chart Page View

◆ Email Alerts Page

Figure 8.5 Email Alerts Page View

◆ Parameter Access Page

Figure 8.6 Parameter Access Page View

◆ Settings Page

Figure 8.7 Settings Page View

9 Troubleshooting

◆ Drive-Side Error Codes

Drive-side error codes appear on the drive keypad. [Fault on page 39](#) lists causes of the errors and possible corrective actions. Refer to the drive Technical Manual for additional error codes that may appear on the drive keypad.

■ Fault

Both *bUS* [Option Communication Error] and *EF0* [Option Card External Fault] can appear as a fault. When a fault occurs, the keypad ALM LED stays lit. When an alarm occurs, the ALM LED flashes.

If communication stops while the drive is running, use these questions as a guide to help remove the fault:

- Did you correctly connect the Modbus TCP/IP™ communication line to the option?
- Is the communication line properly connected to the option? Is it loose?
- Is the PLC program working? Is the controller/PLC CPU stopped?
- Did a momentary power loss interrupt communications?

Code	Name	Causes	Possible Solutions
bUS	Option Communication Error	The drive did not receive a signal from the controller.	<ul style="list-style-type: none"> • Check for wiring errors. • Correct the wiring.
		The communications cable wiring is incorrect.	
		An existing short circuit or communications disconnection	Check disconnected cables and short circuits and repair as needed
		A data error occurred due to electric interference	<ul style="list-style-type: none"> • Prevent noise in the control circuit, main circuit, and ground wiring. • If you identify a magnetic contactor as a source of noise, install a surge absorber to the contactor coil. • Use only recommended cables or other shielded line. Ground the shield on the controller side or the drive input power side. • Separate all communication wiring from drive power lines. Install an EMC noise filter to the drive power supply input. • Decrease the effects of electrical interference from the controller.
		Option is damaged	If there are no problems with the wiring and the error continues to occur, replace the option.
		Connection Time-out	Check if the CPU of the controller is not stopped.
		Duplicate IP Address found on network	Change to a different IP address. If <i>F7-13 = 0</i> [Address Mode at Startup = Static], change parameters <i>F7-01</i> to <i>F7-04</i> [IP Address 1 to 4].
EF0	Option Card External Fault	The option received an external fault from the controller.	<ol style="list-style-type: none"> 1. Find the device that caused the external fault and remove the cause. 2. Clear the external fault input from the controller.
		A programming error occurred on the controller side.	Examine the operation of the controller program.

Code	Name	Causes	Possible Solutions
oFA00	Option Card Connection Error (CN5-A)	The option connected to connector CN5-A is not compatible.	Connect the option to the correct connector. • Use connector CN5-A when you connect the option. To use other options, refer to those option manuals.
		Invalid DIP switch S1 setting	Set the option DIP switch S1 as shown in Figure 5.2 . Monitor, U4-75 [Communication OPT Protocol] will display the DIP switch S1 setting.
oFA01	Option Card Fault (CN5-A)	The option connected to option port CN5-A was changed during run.	<ol style="list-style-type: none"> De-energize the drive. Connect the option to the correct option port.
oFA03, oFA04	Option Card Error (CN5-A)	A fault occurred in the option.	<ol style="list-style-type: none"> De-energize the drive. Make sure that the option is correctly connected to the connector. If the problem continues, replace the option.
oFA30 to oFA43	Option Card Connection Error (CN5-A)	A fault occurred in the option.	<ol style="list-style-type: none"> De-energize the drive. Make sure that the option is correctly connected to the connector. If the problem continues, replace the option.
oFb00	Option Not Compatible with Port	The option connected to connector CN5-B is not compatible.	Connect the option to the correct connector. • Use connector CN5-A when you connect the option. To use other options, refer to those option manuals.
oFb02	Option Fault	An option of the same type is already installed in option port CN5-A, CN5-B, or CN5-C.	Connect the option to the correct option port.
oFC00	Option Fault (CN5-B)	The option connected to connector CN5-C is not compatible.	Connect the option to the correct connector. • Use connector CN5-A when you connect the option. To use other options, refer to those option manuals.
oFC02	Option Fault	An option of the same type is already installed in option port CN5-A, CN5-B, or CN5-C.	Connect the option to the correct option port.
PSE	JOHB-SMP3 Protocol Set Error	Invalid DIP switch S1 setting	Set the option DIP switch S1 as shown in Figure 5.2 . Monitor, U4-75 [Communication OPT Protocol] will display the DIP switch S1 setting.

■ Minor Faults and Alarms

Code	Name	Causes	Possible Solutions
CyPo	Cycle Power to Active Parameters	Comm. Option Parameter Not Upgraded	Re-energize the drive to update the communication option parameters.
PA1	PLC Alarm 1	Port 1 is at a link speed different from Port 2 (100 Mbps and 10 Mbps). Data will not be passed between the two ports in this condition.	Set F7-14 = 1 [Duplex Mode Selection = Auto/Auto (Auto Negotiation/Auto Negotiation)], set the two connected nodes to the same speed, and make sure that F7-15 ≠ 101 or 102 [Communication Speed Selection ≠ 10/100 Mbps (10 Mbps/100 Mbps) or 100/10 Mbps (100 Mbps/10 Mbps)].

◆ bUS Fault Tolerance

■ bUS Fault Auto-Restart

Parameter F6-14 [BUS Error Auto Reset] will appear when the option is installed.

Setting F6-14 = 0 [Disabled] or F6-01 = 3, 4, 5 [Alarm Only, Alarm (Run at d1-04), Alarm - Ramp Stop] will not affect standard default drive behavior.

Setting F6-14 = 1 [Enabled] AND F6-01 = 0, 1, 2 [Ramp to Stop, Coast to Stop, Fast Stop (Use C1-09)] will cause the following operation:

- The bUS fault occurs after F7-16 [Timeout Value] delay and the Run command is removed from the drive.
- Then the option throws a bUS fault to the drive.
- When the condition is removed, the option commands a fault reset and returns control of the drive to the Modbus TCP/IP network.

Note:

The option will only read parameter F6-01 and F6-14 from the drive during power-up.

■ bUS Fault Delay

Parameter F7-16 [Timeout Value] will appear when the option is installed. The setting value of F7-16 is the length of time that the option will delay sending the bUS fault to the drive. The status LEDs on the option are not affected by the bUS delay time set in F7-16; the LEDs will indicate the bUS condition immediately.

Note:

The option will only read parameter F7-16 from the drive during power-up.

◆ Option Error Codes

■ Option Fault Monitors *U6-98* and *U6-99*

The option can declare error/warning conditions via drive monitor parameters on the drive keypad as shown in [Table 9.1](#).

Table 9.1 Option Fault Monitor Descriptions

Status	Fault Declared	Status Value (<i>U6-98/U6-99</i>)	Description
No faults	-	0	No faults
Fatal error occurred	EF0	3	Network sent a message to force this node to the fault state.
Connection Time-out	bUS	1101	The control connection timer is more than the setting value of <i>F7-16 [Timeout Value]</i> .
Duplicate IP Address	bUS	1102	This node and at least one other node have the same IP Address.
Default MAC Address	-	1103	MAC Address programmed into the option is not factory default setting. Note: Contact Yaskawa or your nearest sales representative for more information.
Network Link Down	bUS	1104	No network link to option.
Web Interface Setting Error	-	1110	Failure to read the web interface setting.

Two drive monitor parameters, *U6-98 [First Fault]* and *U6-99 [Current Fault]* assist the user in network troubleshooting.

- *U6-98* displays the first declared fault since the last power cycle. *U6-98* is only cleared upon drive power-up.
- *U6-99* displays the present option status. *U6-99* is cleared upon a network-issued fault reset and upon power-up.

If another fault occurs while the original fault is still active, parameter *U6-98* retains the original fault value and *U6-99* stores the new fault status value.

◆ Self RAM Check

Use these procedures to do a self RAM check for all areas including unused areas.

Note:

- The self RAM check completes in approximately 2.5 minutes.
- When you start the self RAM check, the drive will detect *oFA00 [Option Not Compatible with Port]*.

1. Set DIP switch S1 as shown in [Figure 9.1](#).

Note:

Use non-conductive tweezers or a tool with a tip width of approximately 0.5 mm (0.02 in) to set DIP switch S1.

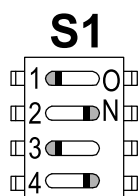

Figure 9.1 DIP Switch S1 Settings for the Self RAM Check

2. Apply power to the option.
This will start the self RAM check.
3. Look at the LEDs on the option to see the status of the self RAM check.
Refer to [Table 9.2](#) for more information.

Table 9.2 LED States during Self RAM Check

Self RAM Check Status	LED States	
	MS	NS
Checking	Lit in green	OFF
Successful termination	Lit in green	Lit in green
Abnormal termination	Lit in red	Lit in red

10 European Standards



Figure 10.1 CE Mark

The CE mark indicates compliance with European safety and environmental regulations.

European standards include the Machinery Directive for machine manufacturers, the Low Voltage Directive for electronics manufacturers, and the EMC Directive for controlling noise.

It is required for engaging in business and commerce in Europe.

This option displays the CE mark based on the EMC guidelines.

EMC Directive: 2014/30/EU

Drives used in combination with this option and devices used in combination with the drive must also be CE certified and display the CE mark.

When using drives displaying the CE mark in combination with other devices, it is ultimately the responsibility of the user to ensure compliance with CE standards. Verify that conditions meet European standards after setting up the device.

◆ EMC Directive Compliance

This option is tested according to European standard EN 61800-3:2004/A1:2012 and complies with the EMC Directive. The CE marking is declared based on the harmonized standards.

■ Option Installation

Verify the following installation conditions to make sure that other devices and machinery used with this option and drive also comply with EMC Directive:

1. Use dedicated shield cable for the option and external device (encoder, I/O device, controller), or run the wiring through a metal conduit.
2. Keep wiring as short as possible and ground the largest possible surface area of the shield to the metal panel according to [Figure 10.2](#), [Figure 10.3](#), and [Figure 10.4](#).

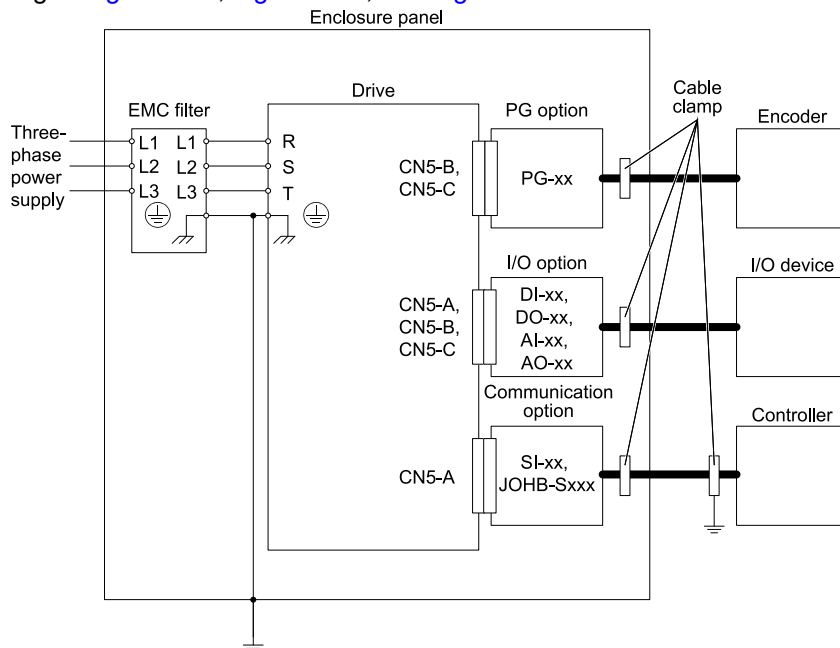

Figure 10.2 Option Installation for CE Compliance: 1000-Series, GA700, GA800, CR700

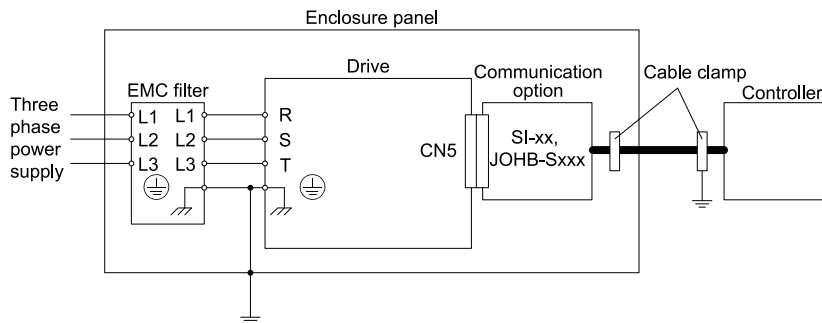

Figure 10.3 Option Installation for CE Compliance: GA500, HV600

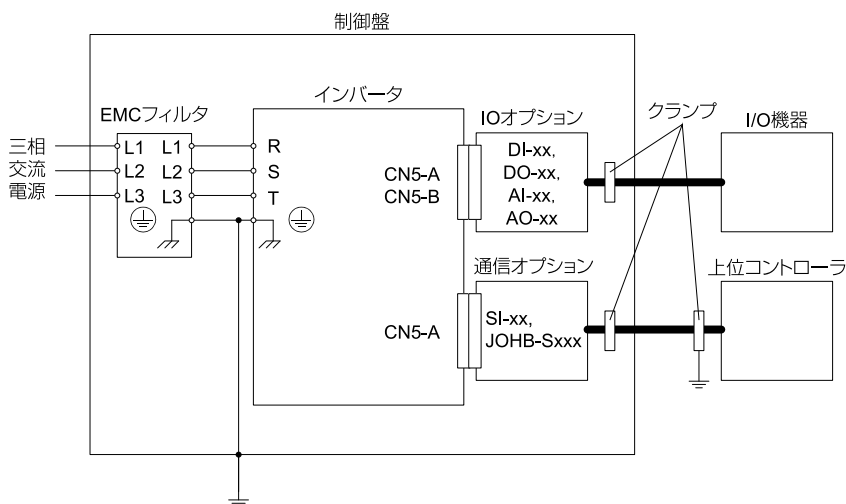
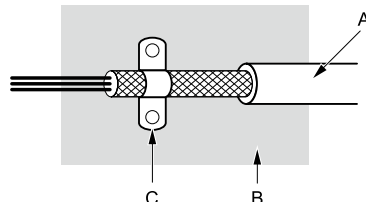

Figure 10.4 Option Installation for CE Compliance: FP605

3. Ground the largest possible surface area of the shield to the metal panel.
Yaskawa recommends using cable clamps.



A - Braided shield cable
B - Metal panel

C - Cable clamp (conductive)

Figure 10.5 Ground Area

11 Specifications

◆ Specifications

Table 11.1 Option Specifications

Items	Specifications
Model	JOHB-SMP3
Supported Messages	<ul style="list-style-type: none"> • Read Multiple Registers (03 (Hex.)) • Write Single Register (06 (Hex.)) • Write Multiple Registers (10 (Hex.)) • Read and Write Registers (17 (Hex.)) Commands that support multiple registers have a maximum Read and Write size of 16 registers.
Modbus TCP/IP Specifications	Modbus-IDA
Recommended Connector Type	Shielded Cat5e cable
Physical Layer Type	Ethernet Isolated Physical Layer

12 Disposal

Items	Specifications
IP Address Setting	Programmable from drive keypad or network
Communication Speed	Programmable from drive keypad or network: 10/100 Mbps, auto-negotiate.
Number of Connections	<ul style="list-style-type: none">• Modbus TCP/IP: 10• Web page connections: 2
Duplex Mode	<ul style="list-style-type: none">• Half/Half• Auto-negotiate• Full/Full
Address Startup Mode	<ul style="list-style-type: none">• Static• BOOTP• DHCP
Ambient Temperature	-10°C - +50°C (14°F - 122°F)
Humidity	Up to 95% RH (non-condensing)
Storage Temperature	-20°C - +60°C (-4°F - 140°F) allowed for short-term transport of the product
Area of Use	Indoors and not near: <ul style="list-style-type: none">• Oil mist, corrosive gas, flammable gas, or dust• Radioactive materials or flammable materials, including wood• Dangerous gases or fluids• Salt• Direct sunlight• Falling objects
Altitude	Up to 1000 m (3281 ft) Note: This option can be used at a maximum of 4000 m (13123 ft) depending on the model of the drive and the operating conditions. Refer to the drive manuals for more information.

12 Disposal

◆ Disposal Instructions

Correctly dispose of the product and packing material as specified by applicable regional, local, and municipal laws and regulations.

◆ WEEE Directive



The wheeled bin symbol on this product, its manual, or its packaging identifies that you must recycle it at the end of its product life.

You must discard the product at an applicable collection point for electrical and electronic equipment (EEE). Do not discard the product with usual waste.

Revision History

Date of Publication	Revision Number	Section	Revised Content
June 2022	1	All	Addition: Information on FP605
		2	Addition: For Yaskawa Customers in the North or South America Regions
		10	Revision: Reviewed and corrected "Master" Deletion: EU Declaration of Conformity
March 2021	-	-	First Edition

YASKAWA AC Drive Option Modbus TCP/IP Technical Manual

DRIVE CENTER (INVERTER PLANT)

2-13-1, Nishimiyaichi, Yukuhashi, Fukuoka, 824-8511, Japan
Phone: +81-930-25-2548 Fax: +81-930-25-3431
www.yaskawa.co.jp

YASKAWA ELECTRIC CORPORATION

New Pier Takeshiba South Tower, 1-16-1, Kaigan, Minatoku, Tokyo, 105-6891, Japan
Phone: +81-3-5402-4502 Fax: +81-3-5402-4580
www.yaskawa.co.jp

YASKAWA AMERICA, INC.

2121, Norman Drive South, Waukegan, IL 60085, U.S.A.
Phone: +1-800-YASKAWA (927-5292) or +1-847-887-7000 Fax: +1-847-887-7310
www.yaskawa.com

YASKAWA ELÉTRICO DO BRASIL LTDA.

777, Avenida Piraporinha, Diadema, São Paulo, 09950-000, Brasil
Phone: +55-11-3585-1100 Fax: +55-11-3585-1187
www.yaskawa.com.br

YASKAWA EUROPE GmbH

Hauptstraße 185, 65760 Eschborn, Germany
Phone: +49-6196-569-300 Fax: +49-6196-569-398
E-mail: info@yaskawa.eu.com
www.yaskawa.eu.com

YASKAWA ELECTRIC KOREA CORPORATION

18F, Hi Investment & Securities Building, 66 Yeoui-daero, Yeongdeungpo-gu, Seoul, 07325, Korea
Phone: +82-2-784-7844 Fax: +82-2-784-8495
www.yaskawa.co.kr

YASKAWA ASIA PACIFIC PTE. LTD

30A, Kallang Place, #06-01, 339213, Singapore
Phone: +65-6282-3003 Fax: +65-6289-3003
www.yaskawa.com.sg

YASKAWA ELECTRIC (THAILAND) CO., LTD.

59, 1F-5F, Flourish Building, Soi Ratchadapisek 18, Ratchadapisek Road, Huaykwang, Bangkok, 10310, Thailand
Phone: +66-2-017-0099 Fax: +66-2-017-0799
www.yaskawa.co.th

YASKAWA ELECTRIC (CHINA) CO., LTD.

22F, Link Square 1, No.222, Hubin Road, Shanghai, 200021, China
Phone: +86-21-5385-2200 Fax: +86-21-5385-3299
www.yaskawa.com.cn

YASKAWA ELECTRIC (CHINA) CO., LTD. BEIJING OFFICE

Room 1011, Tower W3 Oriental Plaza, No. 1, East Chang An Avenue,
Dong Cheng District, Beijing, 100738, China
Phone: +86-10-8518-4086 Fax: +86-10-8518-4082

YASKAWA ELECTRIC TAIWAN CORPORATION

12F, No. 207, Section 3, Beishin Road, Shindian District, New Taipei City 23143, Taiwan
Phone: +886-2-8913-1333 Fax: +886-2-8913-1513 or +886-2-8913-1519
www.yaskawa.com.tw

YASKAWA INDIA PRIVATE LIMITED

#17/A, Electronics City, Hosur Road, Bengaluru, 560 100 (Karnataka), India
Phone: +91-80-4244-1900 Fax: +91-80-4244-1901
www.yaskawaindia.in

YASKAWA

YASKAWA ELECTRIC
CORPORATION

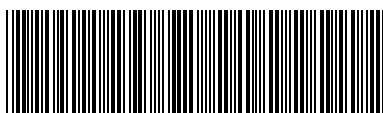

SIEPC73060001

In the event that the end user of this product is to be the military and said product is to be employed in any weapons systems or the manufacture thereof, the export will fall under the relevant regulations as stipulated in the Foreign Exchange and Foreign Trade Regulations. Therefore, be sure to follow all procedures and submit all relevant documentation according to any and all rules, regulations and laws that may apply.

Specifications are subject to change without notice for ongoing product modifications and improvements.

© 2021 YASKAWA ELECTRIC CORPORATION

MANUAL NO. SIEP C730600 01B <1>-0
Published in Japan June 2022
22-3-23
Original Instructions