

YASKAWA AC Drive Option Modbus TCP/IP Installation Manual

Type: SI-EM3

To properly use the product, read this manual thoroughly and retain for easy reference, inspection, and maintenance. Ensure the end user receives this manual.

安川インバータ オプション Modbus TCP/IP通信 取扱説明書

形 式 SI-EM3

製品を安全にお使いいただくために、本書を必ずお読みください。
また、本書をお手元に保管していただくとともに、最終的に本製品をご使用になるユーザー様のお手元に確実に届けられるよう、お取り計らい願います。

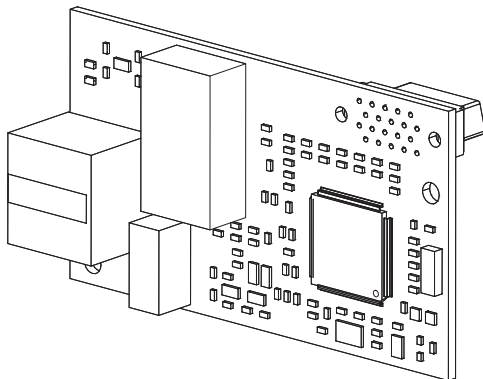

Copyright © 2016 YASKAWA ELECTRIC CORPORATION

All rights reserved. No part of this publication may be reproduced, stored in a retrieval system, or transmitted, in any form or by any means, mechanical, electronic, photocopying, recording, or otherwise, without the prior written permission of Yaskawa. No patent liability is assumed with respect to the use of the information contained herein. Moreover, because Yaskawa is constantly striving to improve its high-quality products, the information contained in this manual is subject to change without notice. Every precaution has been taken in the preparation of this manual. Yaskawa assumes no responsibility for errors or omissions. Neither is any liability assumed for damages resulting from the use of the information contained in this publication.

Table of Contents

1	PREFACE AND SAFETY	4
2	OVERVIEW	9
3	RECEIVING	12
4	OPTION COMPONENTS	13
5	INSTALLATION PROCEDURE	17
6	RELATED DRIVE PARAMETERS	40
7	MODBUS TCP/IP MESSAGING	44
8	WEB INTERFACE	49
9	TROUBLESHOOTING	53
10	OPTION INSTALLATION	58
11	SPECIFICATIONS	60

1 Preface and Safety

YASKAWA Electric supplies component parts for use in a wide variety of industrial applications. The selection and application of YASKAWA products remain the responsibility of the equipment designer or end user.

YASKAWA accepts no responsibility for the way its products are incorporated into the final system design. Under no circumstances should any YASKAWA product be incorporated into any product or design as the exclusive or sole safety control. Without exception, all controls should be designed to detect faults dynamically and fail safely under all circumstances. All products designed to incorporate a component part manufactured by YASKAWA must be supplied to the end user with appropriate warnings and instructions as to the safe use and operation of that part. Any warnings provided by YASKAWA must be promptly provided to the end user. YASKAWA offers an express warranty only as to the quality of its products in conforming to standards and specifications published in the manual. **NO OTHER WARRANTY, EXPRESS OR IMPLIED, IS OFFERED.** YASKAWA assumes no liability for any personal injury, property damage, losses, or claims arising from misapplication of its products.

◆ Applicable Documentation

The following manuals are available for the SI-EM3 Option:

SI-EM3 Option

YASKAWA AC Drive Option SI-EM3 Modbus TCP/IP Installation Manual Manual No: TOBP C730600 91 (This book)	This guide is packaged together with the product and contains information necessary to install the option and set related drive parameters.
YASKAWA AC Drive Option SI-EM3 Modbus TCP/IP Technical Manual Manual No: SIEP C730600 91	The technical manual contains detailed information about the option. Access the following sites to obtain the technical manual: U.S.: http://www.yaskawa.com Europe: http://www.yaskawa.eu.com Japan: http://www.e-mechatronics.com Other areas: Check the back cover of these manuals. For questions, contact Yaskawa or a Yaskawa representative.

Yaskawa Drive

YASKAWA AC Drive Manuals	Drive manuals contain basic installation and wiring information in addition to detailed parameter setting, fault diagnostic, and maintenance information. The most recent versions of these manuals are available for download on our documentation websites: U.S.: http://www.yaskawa.com Europe: http://www.yaskawa.eu.com Japan: http://www.e-mechatronics.com Other areas: Check the back cover of these manuals. For questions, contact Yaskawa or a Yaskawa representative.
---------------------------------	---

◆ Terms

- Note:** Indicates supplemental information that is not related to safety messages.
- Option:** YASKAWA AC Drive Option SI-EM3 Modbus TCP/IP
- Drive:**
- YASKAWA AC Drive 1000-Series (A1000, D1000, R1000, U1000, U1000L, Z1000, Z1000U)
 - YASKAWA AC Drive GA700
 - YASKAWA AC Drive GA800
- Keypad**
- LCD Operator for YASKAWA AC Drive 1000-Series
 - LED Operator for YASKAWA AC Drive 1000-Series
 - LCD Keypad for YASKAWA AC Drive GA700 and GA800
 - LED Keypad for YASKAWA AC Drive GA700 and GA800

◆ Registered Trademarks

- Modbus TCP/IP is a trademark of Modbus-IDA.
- All trademarks are the property of their respective owners.

1 Preface and Safety

◆ Supplemental Safety Information

Read and understand this manual before installing, operating, or servicing this option. The option must be installed according to this manual and local codes.

The following conventions are used to indicate safety messages in this manual. Failure to heed these messages could result in serious or possibly even fatal injury or damage to the products or to related equipment and systems.

DANGER

Indicates a hazardous situation, which, if not avoided, will cause death or serious injury.

WARNING

Indicates a hazardous situation, which, if not avoided, could cause death or serious injury.

CAUTION

Indicates a hazardous situation, which, if not avoided, could cause minor or moderate injury.

NOTICE

Indicates an equipment damage message.

■ General Safety

General Precautions

- The diagrams in this section may include options and drives without covers or safety shields to illustrate details. Reinstall covers or shields before operating any devices. The option should be used according to the instructions described in this manual.
- The diagrams in this manual are provided as examples only and may not pertain to all products covered by this manual.
- The products and specifications described in this manual or the content and presentation of the manual may be changed without notice to improve the product and/or the manual.
- Contact Yaskawa or a Yaskawa representative and provide the manual number shown on the front cover to order new copies of the manual.

DANGER

Heed the safety messages in this manual.

Failure to comply will cause death or serious injury.

The operating company is responsible for any injuries or equipment damage resulting from failure to heed the warnings in this manual.

WARNING

Electrical Shock Hazard

Do not attempt to modify or alter the drive or drive circuitry in any way not explained in this manual.

Failure to comply could cause death or serious injury and will void warranty. Yaskawa is not responsible for any modification of the product made by the user. Do not modify this product.

NOTICE

Do not modify the drive or option circuitry.

Failure to comply could result in damage to the drive or option and will void warranty. Yaskawa is not responsible for any modification of the product made by the user.

Do not expose the drive or the option to halogen group disinfectants. Do not pack the drive or the option in fumigated or sterilized wooden materials. Do not sterilize the entire package after packing the product.

Failure to comply could damage electrical components in the option.

2 Overview

This option provides a communications connection between the drive and a Modbus TCP/IP network. The option connects the drive to a Modbus TCP/IP network and facilitates the exchange of data.

This manual explains the handling, installation and specifications of this product.

The option is a communications link to connect industrial devices (such as smart motor controllers, operator interfaces, and variable frequency drives) as well as control devices (such as programmable controllers and computers) to a network. The option is a simple, networking solution that reduces the cost and time to wire and install factory automation devices, while providing interchangeability of like components from multiple vendors.

Install the option/Modbus TCP/IP option on a drive to perform the following functions from a Modbus TCP/IP master device:

- Operate the drive
- Monitor the drive operation status
- Change drive parameter settings

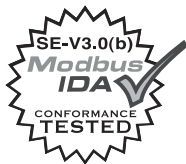

2 Overview

◆ Compatible Products

The option can be used with the products in *Table 1*.

Table 1 Compatible Products

Product Series	Model(s)	Software Version <1>
A1000	CIMR-A□2A□□□□	≥ 1020
	CIMR-A□4A0002 to 4A0675	≥ 1020
	CIMR-A□4A0930 and 4A1200	≥ 3015
	CIMR-A□5A□□□□	≥ 5040 ≥ 1020
D1000	CIMR-D□2A0005 to 4A0370	≥ 2600
	CIMR-D□4A0630	≥ 3014
R1000	CIMR-R□2A03P5 to 4A0300	≥ 2102
U1000	CIMR-U□□A□□□□	≥ 1010
	CIMR-U□□E□□□□	
	CIMR-U□□P□□□□	
	CIMR-U□□W□□□□	
U1000L	CIMR-U□□L□□□□	≥ 6210
	CIMR-U□□F□□□□	
	CIMR-U□□R□□□□	
	CIMR-U□□S□□□□	
Z1000	CIMR-Z□□A□□□□	≥ 1016
Z1000U	CIMR-Z□□A□□□□	≥ 6110
	CIMR-Z□□E□□□□	
	CIMR-Z□□P□□□□	
	CIMR-Z□□W□□□□	
GA700 <2>	CIPR-GA70□□□□□	≥ 1010
GA800 <3>	CIPR-GA80□□□□□	≥ 9010

<1> Refer to “PRG” on the drive nameplate for the software version number.

<2> Before you install the option on a YASKAWA AC Drive GA700, make sure that the option software version is PRG: 8103 or later.

<3> Before you install the option on a YASKAWA AC Drive GA800, make sure that the option software version is PRG: 8104 or later.

- Note:**
1. Refer to the option package labeling in the field designated “PRG” (four digit number)” to identify the option software version.
 2. For Yaskawa customers in the North or South America region:
If your product is not listed in *Table 1*, refer to the web page below to confirm this manual is correct for your product. The web page provides a list of option manuals by product, and a direct link to download a PDF.

Scan QR code



Or refer to: <http://www.yaskawa.com/optionlookup>

3 Receiving

After receiving the option package:







1. Make sure that the option is not damaged and no parts are missing. Contact your sales outlet if the option or other parts appear damaged.

NOTICE: Do not use damaged parts to connect the drive and the option. Failure to comply could damage the drive and option.

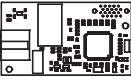
2. Confirm that the model number on the option nameplate and the model listed in the purchase order are the same. Refer to [Figure 1](#) on page 13 for details. Contact the distributor where the option was purchased or contact Yaskawa or a Yaskawa representative about any problems with the option.

◆ Option Package Contents

Table 2 Option Package Contents

Description:	Option	Ground Wire <1>	Screws (M3)	LED Labels			Installation Manual
				A1000, U1000, U1000L	Z1000	GA700 and GA800	
—							
Quantity:	1	1	3 <2>	1	1	1	1

<1> GA700 and GA800 drives do not use the ground wire.

<2> GA700 and GA800 drives use two screws only.

◆ Installation Tools

- A Phillips screwdriver. Phillips screw sizes vary by drive capacity.
- A flat-blade screwdriver (blade depth: 0.4 mm (0.02 in), width: 2.5 mm (0.1 in)).
- A pair of diagonal cutting pliers.
- A small file or medium-grit sandpaper.

4 Option Components

◆ SI-EM3 Option

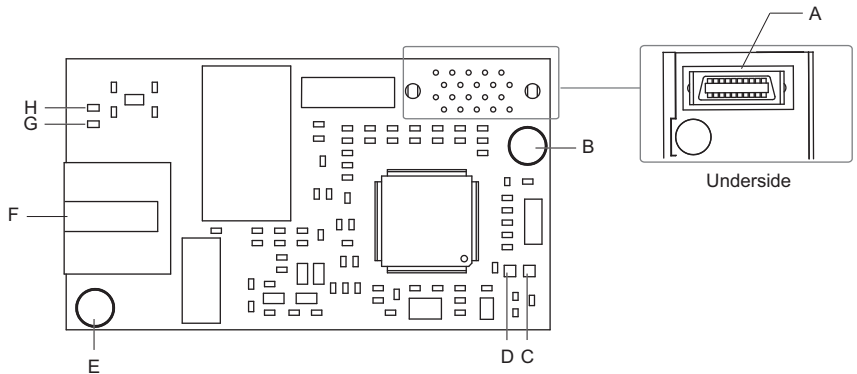

A – Connector (CN5)

B – Installation hole

C – LED (MS) <1>

D – LED (NS) <1>

E – Ground terminal (FE) and installation hole <2>

F – Communication connector CN1 (RJ45)

G – LED (LINK/ACT) <1>

H – LED (10/100) <1>

<1> Refer to *Option LED Display* on page 15 for details on the LEDs.

<2> Connect the provided ground wire during installation. Installation on GA700 and GA800 drives does not require the ground wire.

Figure 1 Option Components

4 Option Components

◆ Communication Connector CN1

The communication connector on the option is a modular RJ45 female connector designated CN1.

CN1 is the connection point for a customer supplied male Modbus network communication cable.

Table 3 Male, 8-way Ethernet Modular Connector (Customer Supplied)

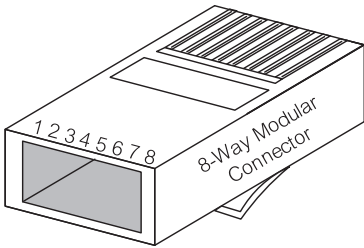
Male Ethernet 8-Way Modular Connector	Pin	Description
	1 (Pair 2)	Transmit data (TXD) +
	2 (Pair 2)	Transmit data (TXD) -
	3 (Pair 3)	Receive data (RXD) +
	4 (Pair 1)	Not used <I>
	5 (Pair 1)	Not used <I>
	6 (Pair 3)	Receive data (RXD) -
	7 (Pair 4)	Not used <I>
	8 (Pair 4)	Not used <I>

<I> Not used for 10 Mbps and 100 Mbps networks.

◆ Option LED Display

The option has four LEDs:

Bi-color Status LEDs:

- Module status (MS) red/green
- Network status (NS) red/green

Green Ethernet LEDs:

- Network speed-10/100 (MS) green
- Link status and network activity-Link/Act (NS) red/green



1000-Series Label

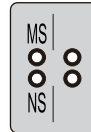

GA700 and GA800 Label

Figure 2 Option LED Labels

4 Option Components

The operational states of the option LEDs after the power-up diagnostic LED sequence is completed are described in *Table 4*. Wait at least 2 seconds for the power-up diagnostic process to complete before verifying the states of the LEDs.

Table 4 Option LED States

Name	Indication		Operating Status	Description
	Color	Status		
MS	–	OFF	Power supply OFF	Power is not being supplied to the drive
	Green	ON	Option operating	The option is operating normally
	Green	Flashing	Option initializing	The option is configuring an IP address
	Red	ON	Fatal error occurred	The option has detected a fatal (unrecoverable) error
	Red	Flashing	Non-fatal error occurred	The option has detected a non-fatal (recoverable) error
NS	–	OFF	Offline or power supply OFF	–
	Green	ON	Online communications established	The option is online and has established connections
	Green	Flashing	Control connection active	The option is online and has an established and active control connection.
	Red	ON	Communications error (fatal)	The option detected a duplicate IP address
10/100 <>	Green	OFF	10 Mbps is established	–
	Green	ON	100 Mbps is established	
LINK/ACT <>	Green	OFF	Link is not established	
	Green	ON	Link is established	
	Green	Flashing	Link is established and there is network activity	

<1> Remove the drive front cover to check the status of the LED. Be careful not to touch the main circuit terminals or the control board in the drive.

5 Installation Procedure

◆ Section Safety

DANGER

Electrical Shock Hazard

Do not inspect, connect, or disconnect any wiring while the drive is energized.

Failure to comply will cause death or serious injury.

Before servicing, disconnect all power to the equipment and wait for at least the time specified on the warning label. The internal capacitor remains charged even after the drive is de-energized. The charge indicator LED will extinguish when the DC bus voltage is below 50 Vdc. When all indicators are OFF, measure for unsafe voltages to confirm the drive is safe.

WARNING

Electrical Shock Hazard

Do not operate equipment with covers removed.

Failure to comply could cause death or serious injury.

The diagrams in this section may include options and drives without covers or safety shields to illustrate details. Reinstall covers and shields before operating the drive and run the drive according to the instructions described in this manual.

Do not allow unqualified personnel to perform work on the drive or option.

Failure to comply could cause death or serious injury.

Only authorized personnel familiar with installation, adjustment, and maintenance of AC drives and options may perform work.

Do not remove covers or touch circuit boards while the drive is energized.

Failure to comply could cause death or serious injury.

5 Installation Procedure

WARNING

Do not use damaged wires, stress the wiring, or damage the wire insulation.

Failure to comply could cause death or serious injury.

Fire Hazard

Tighten all terminal screws to the specified tightening torque.

Loose or overtightened connections could cause erroneous operation and damage to the terminal block or start a fire and cause death or serious injury.

NOTICE

Damage to Equipment

Observe proper electrostatic discharge (ESD) procedures when handling the option, drive, and circuit boards.

Failure to comply could cause ESD damage to circuitry.

Never connect or disconnect the motor from the drive while the drive is outputting voltage.

Improper equipment sequencing could damage the drive.

Do not connect or operate any equipment with visible damage or missing parts.

Failure to comply could further damage the equipment.

Do not use unshielded wire for control wiring.

Failure to comply may cause electrical interference resulting in poor system performance. Use shielded, twisted-pair wires and ground the shield to the ground terminal of the drive.

Properly connect all pins and connectors on the option and drive.

Failure to comply could prevent proper operation and damage equipment.

Confirm that all connections are correct after installing the option and connecting peripheral devices.

Failure to comply could damage the option.

◆ Procedures for Installing and Wiring Options on a Drive

Procedures for installing and wiring options differ depending on the drive model.

Refer to [Table 5](#) to check the procedures for installing and wiring options on a drive.

Table 5 Procedures for Installing and Wiring Options on a Drive

Product Series	Procedures for Installing and Wiring Options on a Drive	Page
A1000	Procedure A	20
D1000	Procedure A	20
R1000	Procedure A	20
U1000	Procedure A	20
U1000L	Procedure A	20
Z1000	Procedure B	26
GA700	Procedure C	33
GA800	Procedure C	33

5 Installation Procedure

■ Procedure A

This section shows the procedure to install and wire the option on a 1000-series drive.

Prepare the Drive for the Option

1. Correctly wire the drive as specified by the manual packaged with the drive.
2. Make sure that the drive functions correctly.
Refer to [Figure 3](#) for an exploded view of the drive with the option and related components for reference in the installation procedure.

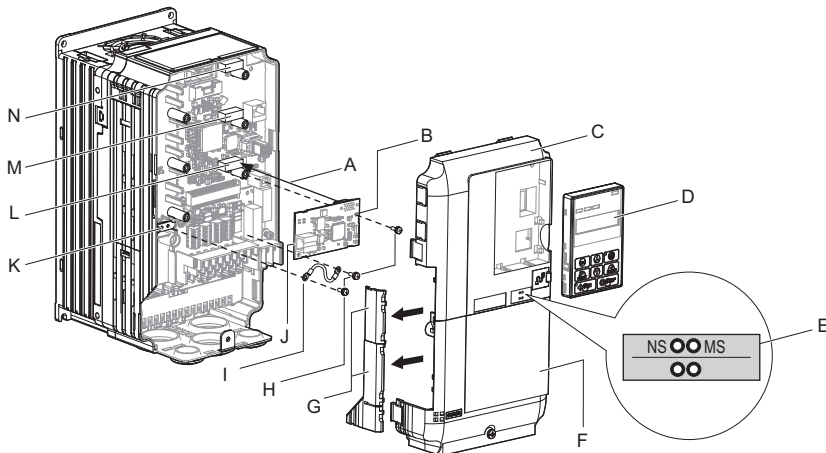

A – Insertion point for CN5 connector

B – SI-EM3 option

C – Drive front cover

D – Keypad

E – LED label

F – Drive terminal cover

G – Removable tabs for wire routing

H – Included screws

I – Ground wire

J – Option modular connector CN1

K – Drive grounding terminal (FE)

L – Connector CN5-A

M – Connector CN5-B
(Not available for communication
option installation.)

N – Connector CN5-C
(Not available for communication
option installation.)

Figure 3 Drive Components with Option

Install the Option

Remove the front covers of the drive before you install the option. Refer to the drive manual for information about how to remove the front covers. Different drive sizes have different cover removal procedures.

You can only install this option into the **CN5-A** connector on the drive control board.

DANGER! Electrical Shock Hazard. Do not inspect, connect, or disconnect any wiring while the drive is energized. Failure to comply will cause death or serious injury. Before servicing, disconnect all power to the equipment and wait for at least the time specified on the warning label. The internal capacitor remains charged even after the drive is de-energized. The charge indicator LED will extinguish when the DC bus voltage is below 50 Vdc. When all indicators are OFF, measure for unsafe voltages to confirm the drive is safe.

1. Shut off power to the drive, wait the appropriate amount of time for voltage to dissipate, then remove the keypad (D) and front covers (C, F). Refer to the manual packaged with the drive for details on keypad and cover removal.

NOTICE: Damage to Equipment. Observe proper electrostatic discharge (ESD) procedures when handling the option, drive, and circuit boards. Failure to comply could cause ESD damage to circuitry.

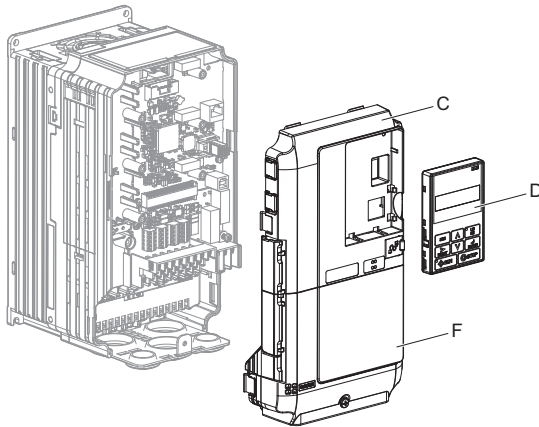

Figure 4 Remove the Keypad, Front Cover, and Terminal Cover

5 Installation Procedure

2. Affix the LED label (E) in the appropriate position on the drive front cover (C).

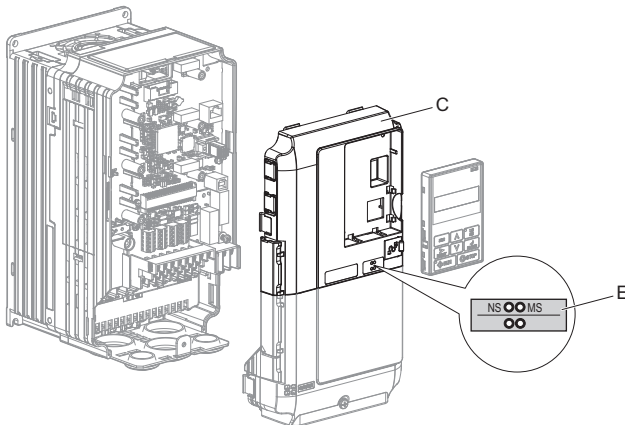

Figure 5 Affix the LED Label

3. Insert the option card (B) into the CN5-A (L) connector on the drive and fasten it into place using one of the included screws (H). Tighten the screw to 0.5 to 0.6 N·m (4.4 to 5.3 in·lb).

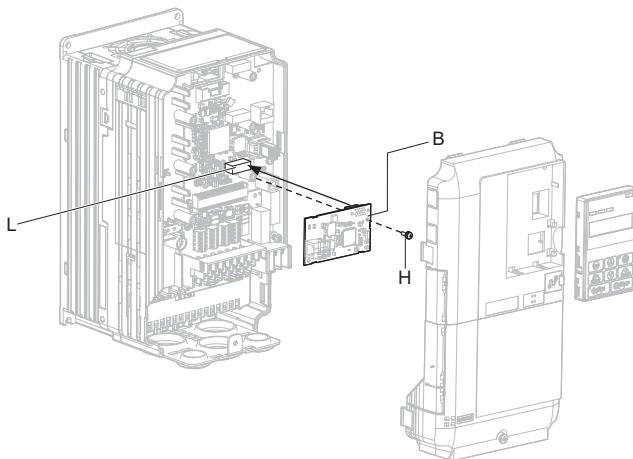

Figure 6 Insert the Option

4. Connect one end of the ground wire (I) to the ground terminal (K) using one of the remaining provided screws (H). Connect the other end of the ground wire (I) to the remaining ground terminal and installation hole on the option (B) using the last remaining provided screw (H). Tighten both screws to 0.5 to 0.6 N·m (4.4 to 5.3 in·lb).

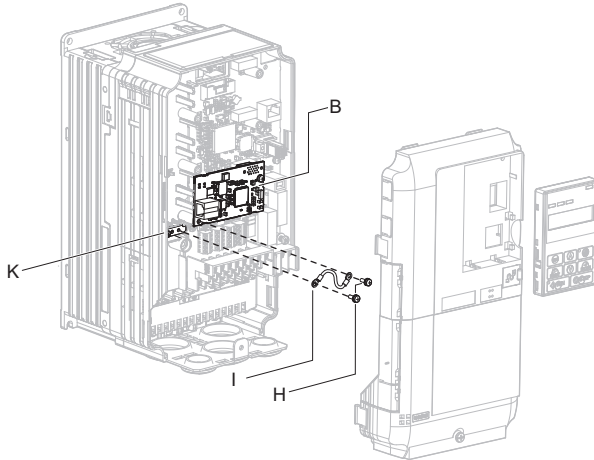

Figure 7 Connect the Ground Wire

Note: The drive has only two ground terminal screw holes (K). Two ground wires should share the same ground terminal when connecting three options.

5 Installation Procedure

5. Route the option wiring inside the enclosure as shown in **Figure 8-B**. Take proper precautions so that the front covers will easily fit back onto the drive. Users may also choose to route the option wiring through openings on the front cover of some models. Remove the perforated tabs on the left side of the front cover as shown in **Figure 8-A** to create the necessary openings on these models. Refer to the Peripheral Devices & Options section of the drive instruction manual for more information.

Note: Separate communication cables from main circuit wiring and other electrical lines to avoid potential sources of electrical interference.

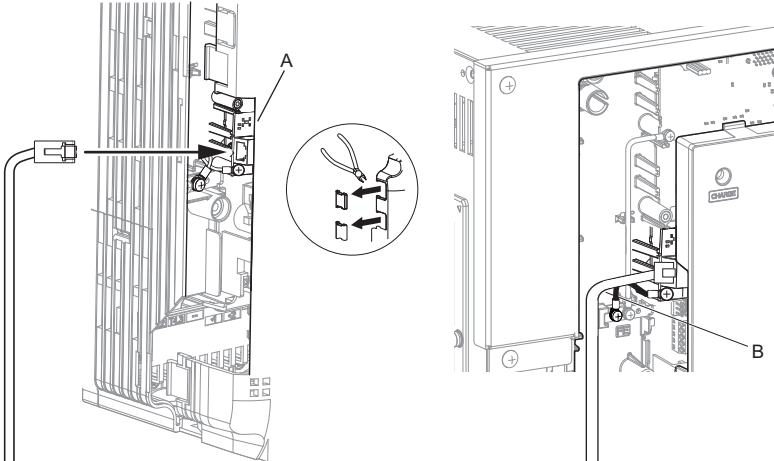

A – Route wires through the openings provided on the left side of the front cover. <1>

B – Use the open space provided inside the drive to route option wiring.

<1> The drive will not meet Enclosed wall-mounted type (IP20/UL Type 1) requirements if wiring is exposed outside the enclosure.

Figure 8 Wire Routing Examples

- Firmly connect the Ethernet communication cable to the option modular connector (CN1). Install Modbus communications cables apart from main-circuit wiring and other electrical and power lines. Ensure the cable end is firmly connected (see [Figure 23](#)). Refer to [Communication Cable Specifications on page 39](#) for details of installing.
- Reattach the drive front covers (C, F) and the keypad (D).

NOTICE: Do not pinch cables between the front covers and the drive. Failure to comply could cause erroneous operation.

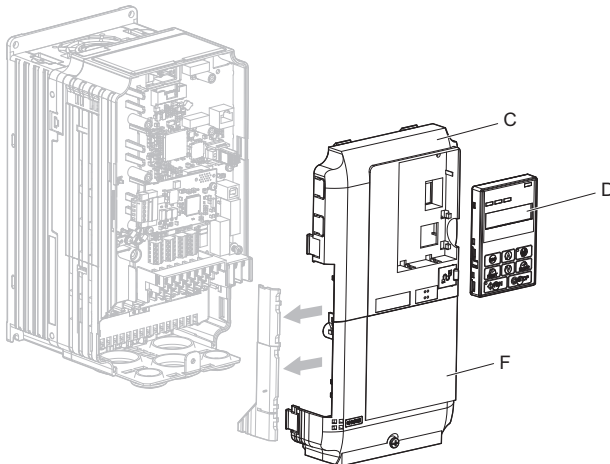

Figure 9 Replace the Front Covers and Keypad

- Set drive parameters in [Table 6](#) for correct option performance.

5 Installation Procedure

■ Procedure B

This section shows the procedure to install and wire the option on a Z1000 Drive.

Prepare the Drive for the Option

Prior to installing the option, wire the drive, make necessary connections to the drive terminals, and verify that the drive functions normally without the option installed. Refer to the User Manual packaged with the drive for information on wiring and connecting the drive.

Figure 10 shows an exploded view of the drive with the option and related components for reference.

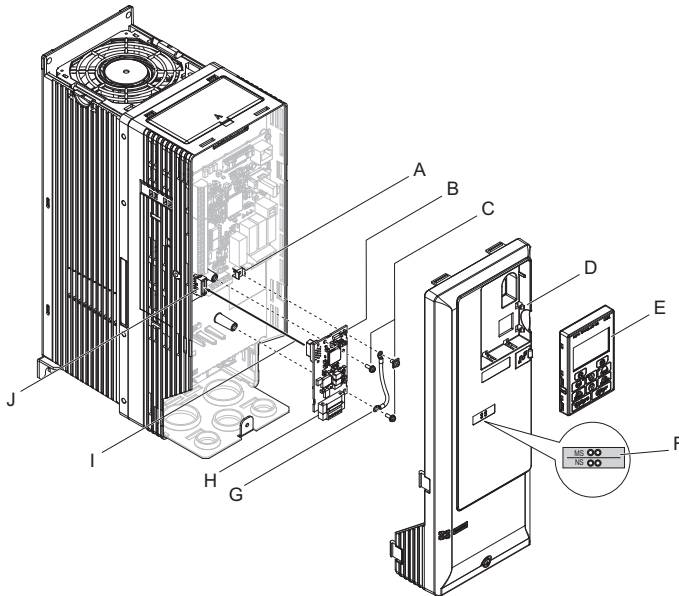

- | | |
|-----------------------------------|-------------------------------|
| A – Drive grounding terminal (FE) | F – LED label |
| B – Option card | G – Ground wire |
| C – Mounting screw | H – Terminal block CN1 |
| D – Drive front cover | I – Insert connector CN5 here |
| E – HOA keypad | J – Connector CN5 |

Figure 10 Drive Components with Option

Installing the Option

Remove the front cover of the drive before you install the option.

Refer to the drive manual for information about how to remove the front covers. Different drive sizes have different cover removal procedures.

You can only install this option into the **CN5-A** connector on the drive control board.

DANGER! *Electrical Shock Hazard. Do not connect or disconnect wiring while the power is on. Failure to comply could result in death or serious injury. Before installing the option, disconnect all power to the drive and wait at least the amount of time specified on the drive front cover safety label. After all indicators are off, measure the DC bus voltage to confirm safe level, and check for unsafe voltages before servicing. The internal capacitor remains charged after the power supply is turned off.*

1. Shut off power to the drive, wait the appropriate amount of time for voltage to dissipate, then remove the HOA keypad (E) and front cover (D).

NOTICE: *Damage to Equipment. Observe proper electrostatic discharge procedures (ESD) when handling the option, drive, and circuit boards. Failure to comply may result in ESD damage to circuitry.*

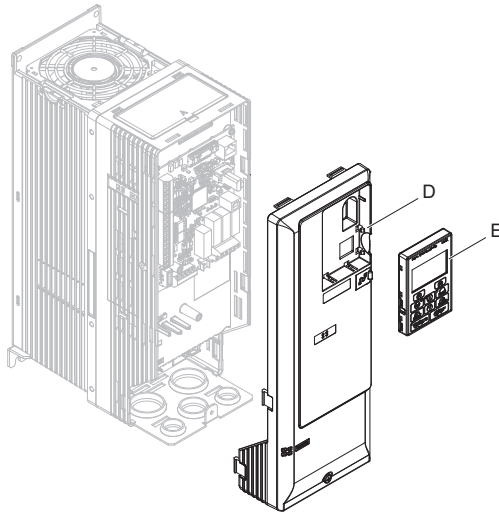

Figure 11 Remove the Front Cover and HOA Keypad

5 Installation Procedure

2. With the front cover and HOA keypad removed, apply the LED label (F) in the appropriate position on the drive front cover (D).

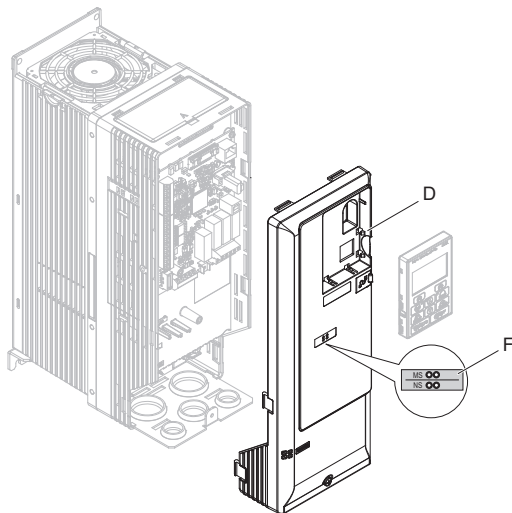

Figure 12 Apply the LED Label

3. Make sure the screws on the left and right sides of the option terminal block (H) are tightened with a tightening torque of 0.5 to 0.6 N·m (4.4 to 5.3 in·lb), then insert the option (B) into the CN5 connector (J) located on the drive and fasten it using one of the included screws (C).

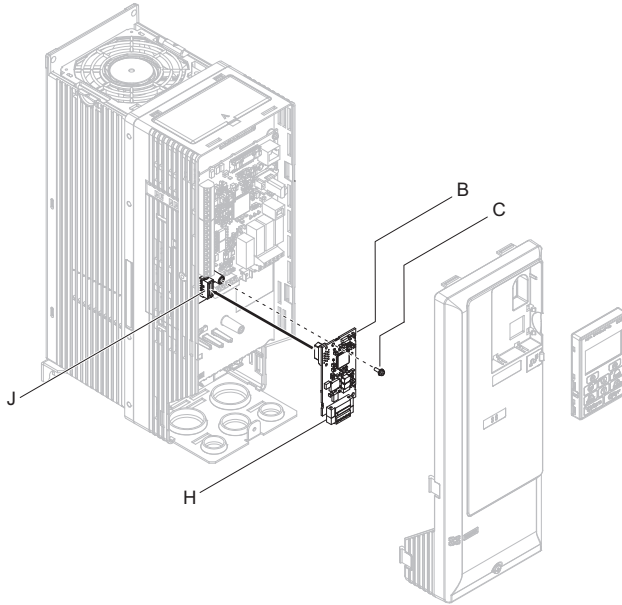

Figure 13 Insert the Option

5 Installation Procedure

4. Connect the ground wire (G) to the ground terminal (A) using one of the remaining provided screws (C). Connect the other end of the ground wire (G) to the ground terminal and installation hole on the option using the last remaining provided screw (C) and tighten both screws to 0.5 to 0.6 N·m (4.4 to 5.3 in·lb).

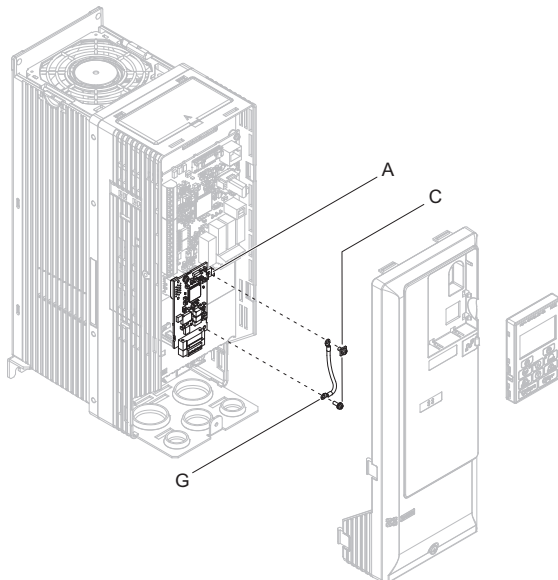

Figure 14 Connecting the Ground Wire

5. Wire the communication cables.

Note: Separate communication cables from main circuit wiring and other electrical lines.

- Connect the Ethernet communication cable to the option modular connector (CN1). To connect the option to a network, insert the RJ45 communication connector of the Cat 5e patch cable into the option modular female connector (CN1). Ensure the cable end is firmly connected (see [Figure 15](#)).

Communication Cable Specifications

Only use cable recommended for Modbus TCP/IP™. Using a cable not specifically recommended may cause the option or drive to malfunction.

Connection Diagram

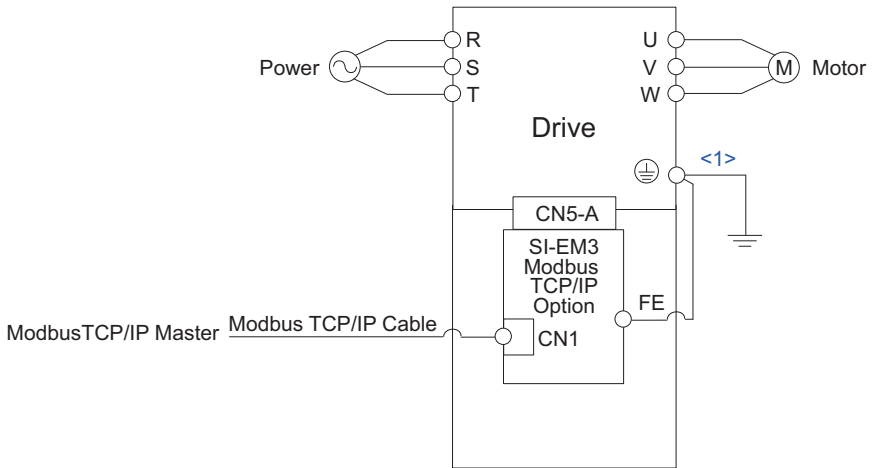

<1> The ground wire provided in the option shipping package must be connected during installation.

Figure 15 Option Connection Diagram

5 Installation Procedure

7. Reattach the drive front cover (D) and the HOA Keypad (E).

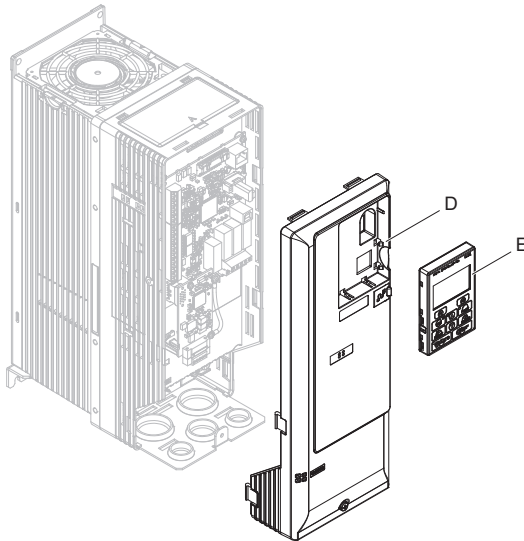

Figure 16 Replace the Front Cover and HOA Keypad

Note: Take proper precautions when wiring the option so that the front covers will easily fit back onto the drive. Make sure no cables are pinched between the front covers and the drive when replacing the covers.

8. Set drive parameters in [Table 7](#) for correct option performance.

■ Procedure C

This section shows the procedure to install and wire the option on a GA700 or GA800 drive.

Prepare the Drive for the Option

Before you install the option on a YASKAWA AC Drive GA700, make sure that the option software version is PRG: 8103 or later.

Before you install the option on a YASKAWA AC Drive GA800, make sure that the option software version is PRG: 8104 or later.

1. Correctly wire the drive as specified by the manual packaged with the drive.
2. Make sure that the drive functions correctly.
Refer to [Figure 17](#) for an exploded view of the drive with the option and related components for reference in the installation procedure.

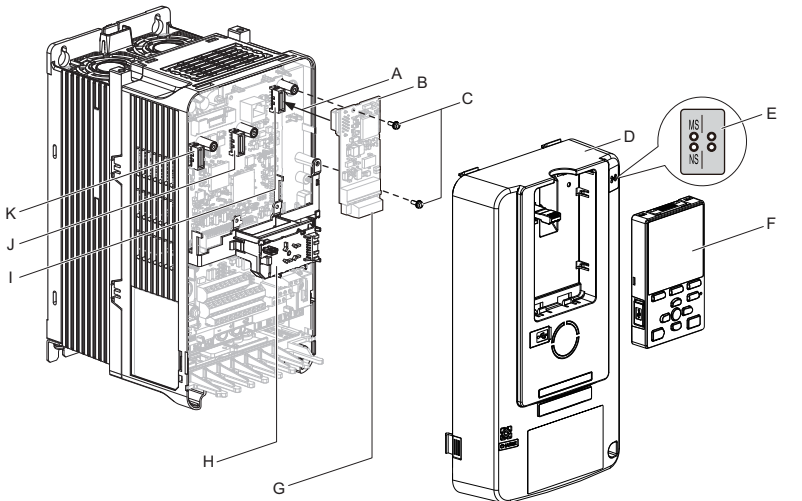

A – Insertion point for CN5 connector

B – SI-EM3 option

C – Included screws

D – Drive front cover

E – LED label

F – Keypad

G – Option modular connector CN1

H – LED Status Ring board

I – Connector CN5-A

J – Connector CN5-B
(Not available for communication option installation.)

K – Connector CN5-C
(Not available for communication option installation.)

Figure 17 Drive Components with Option

5 Installation Procedure

Install the Option

Remove the front cover of the drive before you install the option.

Refer to the drive manual for information about how to remove the front cover. Different drive sizes have different cover removal procedures.

You can only install this option into the **CN5-A** connector on the drive control board.

DANGER! *Electrical Shock Hazard. Do not inspect, connect, or disconnect any wiring while the drive is energized. Failure to comply will cause death or serious injury. Before servicing, disconnect all power to the equipment and wait for at least the time specified on the warning label. The internal capacitor remains charged even after the drive is de-energized. The charge indicator LED will extinguish when the DC bus voltage is below 50 Vdc. When all indicators are OFF, measure for unsafe voltages to confirm the drive is safe.*

1. Affix the LED label (E) in the appropriate position on the drive front cover (D).

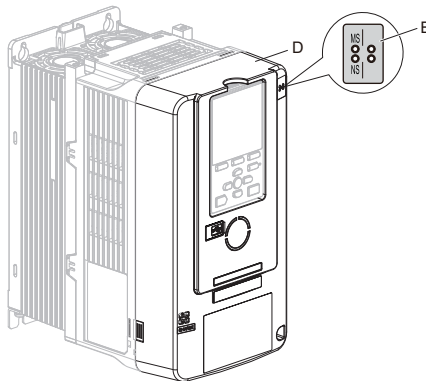

Figure 18 Affix the LED Label

5 Installation Procedure

2. Shut off power to the drive, wait the appropriate amount of time for voltage to dissipate, then remove the front cover (D). Refer to the manual packaged with the drive for details on cover removal.

NOTICE: *Damage to Equipment. Observe proper electrostatic discharge (ESD) procedures when handling the option, drive, and circuit boards. Failure to comply could cause ESD damage to circuitry.*

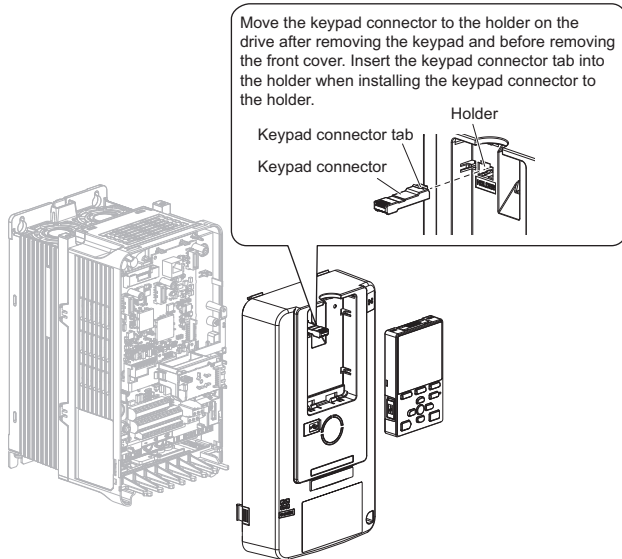

Figure 19 Remove the Front Cover and Keypad

5 Installation Procedure

- Carefully remove the LED Status Ring board (H) and place it on the right side of the drive using the temporary placement holes. Refer to the manual packaged with the drive for details on removing the LED Status Ring board.

NOTICE: Do not remove the LED Status Ring board cable connector. Failure to comply could cause erroneous operation and damage the drive.

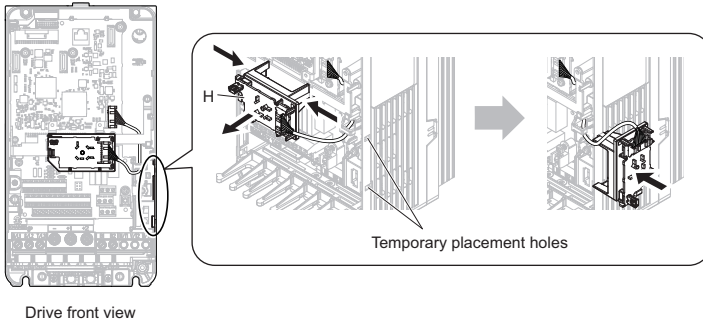

Figure 20 Remove the LED Status Ring Board

4. Insert the option card (B) into the CN5-A connector (I) on the drive and fasten it into place using the included screws (C). Tighten both screws to 0.5 to 0.6 N·m (4.4 to 5.3 in·lb).

Note: Installing the option card on GA700 and GA800 drives requires only two screws and does not require a ground wire. The option package ships with three screws and a ground wire for installation on other product series. Do not use the ground wire or the extra screw.

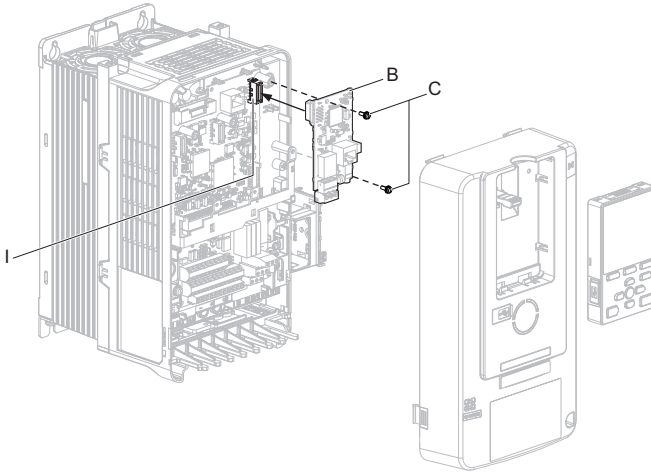

Figure 21 Insert the Option Card

5. Firmly connect the Ethernet communication cable to the option modular connector (CN1). Install Modbus communications cables apart from main-circuit wiring and other electrical and power lines. Ensure the cable end is firmly connected (see [Figure 23](#)). Refer to [Communication Cable Specifications on page 39](#) for details of installing.

Note:

1. Separate communication cables from main circuit wiring and other electrical lines.
2. Maximum transmission distance is 100 m (328 ft). Minimum wiring distance between stations is 0.2 m (7.9 in).

5 Installation Procedure

6. Reattach the LED Status Ring board (H).
Use the open space provided inside the LED Status Ring board to route option wiring.

NOTICE: Do not pinch cables between the front cover or the LED Status Ring board and the drive. Failure to comply could cause erroneous operation.

7. Reattach the drive front cover (D) and the keypad (F).

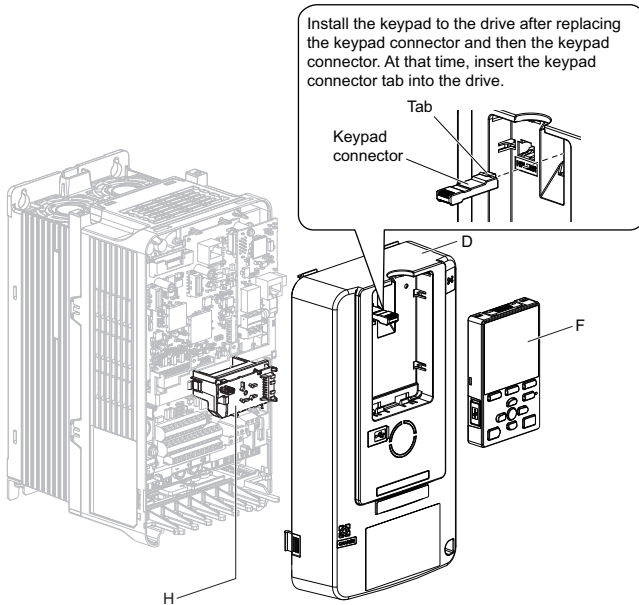

Figure 22 Replace the Front Cover and Keypad

8. Set drive parameters in [Table 6](#) for correct option performance.

◆ Communication Cable Specifications

Use only Ethernet dedicated communication cable; the Yaskawa warranty does not cover other cable types.

◆ Option Connection Diagram

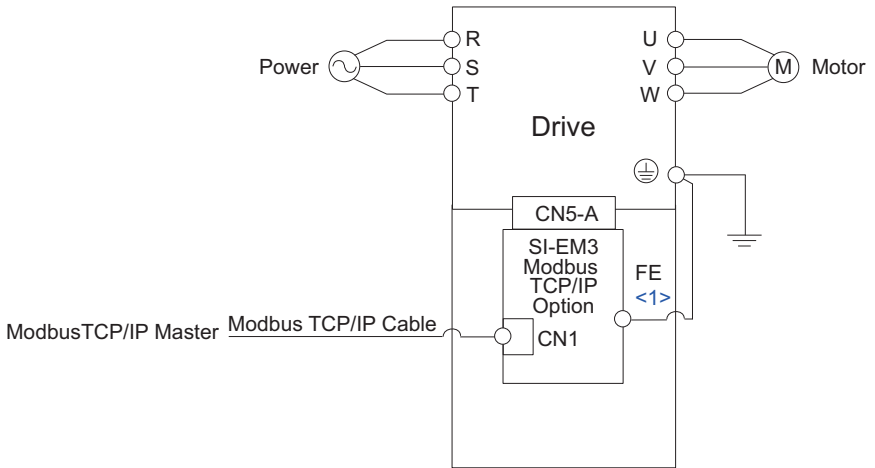

<1> Connect the provided ground wire for installations on 1000-series drives. The ground wire is not necessary for installation on GA700 or GA800 drives.

Figure 23 Option Connection Diagram

6 Related Drive Parameters

The parameters in **Table 6** set the drive for operation with the option. Confirm proper setting of all parameters in **Table 6** before starting network communications. Refer to the manual packaged with the drive for details on setting parameters.

Note: Hex.: MEMOBUS addresses that you can use to change parameters over network communication are represented in hexadecimal numbers.

Table 6 Related Parameter Settings

No. (Hex.)	Name	Description	Values
b1-01 (0180) <I>	Reference 1 Source	Selects the input method for frequency reference. 0: Keypad 1: Analog Input 2: Memobus/Modbus Communications 3: Option PCB 4: Pulse Train Input	Default: 1 Range: 0 to 4 (Set to 3)
b1-02 (0181) <I>	Run Command 1 Source	Selects the input method for the Run command. 0: Keypad 1: Digital Input 2: Memobus/Modbus Communications 3: Option PCB	Default: 1 Range: 0 to 3 (Set to 3)
F6-01 (03A2)	Communication Error Selection	Selects drive response when a bUS error is detected during communications with the option. 0: Ramp to Stop 1: Coast to Stop 2: Fast Stop (Use C1-09) 3: Alarm Only <2> 4: Alarm - Run at d1-04 <2> <3> 5: Alarm - Ramp to Stop <3>	Default: 1 Range: 0 to 5 <4>
F6-02 (03A3)	Comm External Fault (EF0) Detect	Selects the condition for external fault detection (EF0). 0: Always detected 1: Detection during run only	Default: 0 Range: 0, 1
F6-03 (03A4)	Comm External Fault (EF0) Select	Selects drive response for external fault input (EF0) detection during option communications. 0: Ramp to Stop 1: Coast to Stop 2: Fast Stop (Use C1-09) 3: Alarm Only <2>	Default: 1 Range: 0 to 3
F6-06 (03A7) <S>	Torque Reference/Limit by Comm	Enabling this parameter allows d5-01 to determine whether the value is read as the Torque Limit value (d5-01 = 0) or the Torque Reference value (d5-01 = 1). 0: Disabled 1: Enabled <6>	Default: 0 Range: 0, 1
F6-07 (03A8)	MultiStep Ref Priority Select	0: MultiStep References Disabled 1: MultiStep References Enabled	Default: 0 Range: 0, 1

6 Related Drive Parameters

No. (Hex.)	Name	Description	Values
F6-08 (036A)	Comm Parameter Reset @Initialize	Selects whether communication-related parameters F6-□□ and F7-□□ are set back to original default values when the drive is initialized using parameter A1-03. 0: No Reset - Parameters retained 1: Reset - Back to factory default Note: The setting value is not changed even when F6-08 is set to 1 and the drive is initialized using A1-03.	Default: 0 <7> Range: 0, 1
F6-14 (03BB)	Bus Error Auto Reset	Sets the automatic reset function for BUS [Option Communication Errors]. 0: Disabled 1: Enabled	Default: 0 Range: 0, 1
F6-15 (0B5B) <8>	Comm. Option Parameters Reload	Selects whether F6-□□/□□/□□/□□ communication-related parameters changed are enabled. 0: Reload at Next Power Cycle 1: Reload Now 2: Cancel Reload Request Note: F6-15 is reset to 0 after setting 1 or 2.	Default: 0 Range: 0 to 2
F7-01 (03E5) <7> <9> <10>	IP Address 1	Sets the static/fixed IP address. Parameter F7-01 sets the most significant octet.	Default: 192 Min: 0 Max: 255
F7-02 (03E6) <7> <9> <10>	IP Address 2	Sets the static/fixed IP address. Parameter F7-02 sets the second most significant octet.	Default: 168 Min: 0 Max: 255
F7-03 (03E7) <7> <9> <10>	IP Address 3	Sets the static/fixed IP address. Parameter F7-03 sets the third most significant octet.	Default: 1 Min: 0 Max: 255
F7-04 (03E8) <7> <9> <10>	IP Address 4	Sets the static/fixed IP address. Parameter F7-04 sets the fourth most significant octet.	Default: 20 Min: 0 Max: 255
F7-05 (03E9) <7>	Subnet Mask 1	Sets the static/fixed Subnet Mask. Parameter F7-05 sets the most significant octet.	Default: 255 Min: 0 Max: 255
F7-06 (03EA) <7>	Subnet Mask 2	Sets the static/fixed Subnet Mask. Parameter F7-06 sets the second most significant octet.	Default: 255 Min: 0 Max: 255
F7-07 (03EB) <7>	Subnet Mask 3	Sets the static/fixed Subnet Mask. Parameter F7-07 sets the third most significant octet.	Default: 255 Min: 0 Max: 255

6 Related Drive Parameters

No. (Hex.)	Name	Description	Values
F7-08 (03EC) <7>	Subnet Mask 4	Sets the static/fixed Subnet Mask. Parameter F7-08 sets the fourth most significant octet.	Default: 0 Min: 0 Max: 255
F7-09 (03ED) <7>	Gateway Address 1	Sets the static/fixed Gateway address. Parameter F7-09 sets the most significant octet.	Default: 192 Min: 0 Max: 255
F7-10 (03EE) <7>	Gateway Address 2	Sets the static/fixed Gateway address. Parameter F7-10 sets the second most significant octet.	Default: 168 Min: 0 Max: 255
F7-11 (03EF) <7>	Gateway Address 3	Sets the static/fixed Gateway address. Parameter F7-11 sets the third most significant octet.	Default: 1 Min: 0 Max: 255
F7-12 (03F0) <7>	Gateway Address 4	Sets the static/fixed Gateway address. Parameter F7-12 sets the fourth most significant octet.	Default: 1 Min: 0 Max: 255
F7-13 (03F1) <7>	Address Mode at Startup	Selects how the option address is set. 0: Static <10> 1: BOOTP 2: DHCP	Default: 2 Range: 0 to 2
F7-14 (03F2)	Duplex Mode Selection	Selects duplex mode setting. 0: Half/Half 1: Auto/Auto 2: Full/Full 3: Half/Auto 4: Half/Full 5: Auto/Half 6: Auto/Full 7: Full/Half 8: Full/Auto	Default: 1 Range: 0 to 8
F7-15 (03F3) <11>-<12>	Communication Speed Selection	Sets the communication speed. 10: 10/10 Mbps 100: 100/100 Mbps 101: 10/100 Mbps 102: 100/10 Mbps	Default: 10 Range: 10 to 102
F7-16 (03F4)	Timeout Value	Sets the time-out value for communication loss detection in tenths of a second. A value of 0 disables the connection time-out. Example: An entered value of 100 represents 10.0 seconds.	Default: 0.0 Min: 0.0 Max: 30.0
H5-11 (043C)	Communications ENTER Function Selection	Selects whether an Enter command is necessary to change parameter values via MEMOBUS/Modbus communications. 0: Parameter changes are activated when ENTER command is written 1: Parameter changes are activated immediately without use of ENTER command	Default: 0 <13> Range: 0, 1

- <1> Set b1-02 = 3 to start and stop the drive with the Modbus TCP/IP master device using serial communications. Set b1-01 = 3 to control the frequency reference of the drive via the master device.
- <2> Setting this parameter to 3 or 4 will cause the drive to continue operation after detecting a fault. Take proper measures such as installing an emergency stop switch when using settings 3 or 4.
- <3> Refer to the drive manual to know if settings 4 and 5 are available. Settings 4 and 5 are available in A1000 software versions PRG: 1021 and later.
- <4> The setting range for 1000-Series drives is different for different software versions. Refer to the instruction manual of a specific drive for more information.
- <5> Control method availability of this parameter depends on product series.
 - 1000-Series Drives: Parameter is available in CLV, AOLV/PM, and CLV/PM. In AOLV/PM, this value is read as the Torque Limit.
 - GA700, GA800 Drives: Parameter is available in OLV, CLV, AOLV, AOLV/PM, CLV/PM, and EZOLV. In OLV and EZOLV, this value is read as the Torque Limit.
- <6> The setting specifies that network communications provide the torque reference or torque limit. The motor may not rotate if the PLC does not supply a torque reference or torque limit.
- <7> Set F7-01 to F7-12 when F7-13 is set to 0.
- <8> Not available on 1000-series drives.
- <9> Cycle power for setting changes to take effect. Set F6-15 to 1 (Enable), to have settings take effect immediately on non-1000 series drives.
- <10> Set F7-01 to F7-04 when F7-13 is set to 0. All IP Addresses (F7-01 to F7-04) must be unique.
- <11> Set F7-15 when F7-14 is not set to 1.
- <12> Only the first portion of the setting is used. The second portion is ignored.
- <13> The default setting is different for different product series. Refer to the instruction manual of a specific drive for more information.

Table 7 Option Monitors

No.	Name	Description	Range
U6-80 to U6-83	OPT IP ADR 1 to 4	Displays IP Address currently available; <ul style="list-style-type: none"> • U6 -80: First octet • U6 -81: Second octet • U6 -82: Third octet • U6 -83: Forth octet 	0 to 255
U6-84 to U6-87	Online Subnet 1 to 4	Displays subnet currently available; <ul style="list-style-type: none"> • U6 -84: First octet • U6 -85: Second octet • U6 -86: Third octet • U6 -87: Forth octet 	0 to 255
U6-88 to U6-91	Online Gateway	Displays gateway currently available; <ul style="list-style-type: none"> • U6 -88: First octet • U6 -89: Second octet • U6 -90: Third octet • U6 -91: Forth octet 	0 to 255
U6-92	Online Speed	Displays CN1 Port 1 link speed currently available.	10: 10 Mbps 100: 100 Mbps
U6-93	Online Duplex	Displays CN1 Port 1 duplex setting currently available.	0: Half, 1: Full
U6-97	OPT SPARE 4	Displays option software version.	–
U6-98	First Fault	Displays first option fault. Refer to <i>Option Fault Monitors U6-98 and U6-99 on page 56</i> for details.	–
U6-99	Current Fault	Displays current option fault. Refer to <i>Option Fault Monitors U6-98 and U6-99 on page 56</i> for details.	–

7 Modbus TCP/IP Messaging

◆ Modbus TCP/IP Overview

The Modbus TCP/IP protocol is essentially the Modbus protocol over an Modbus TCP/IP network. A master controller (typically a PLC) sends commands to slave devices, which then perform the specified functions and send a response to the master. The drive using the option has slave functionality.

■ Supported Modbus TCP/IP Commands

Table 8 Supported Modbus TCP/IP Commands

Function Code	Function Name
03H	Read Multiple Registers
06H	Write Single Register
10H	Write Multiple Registers
17H	Read/Write Multiple Registers

■ Drive Modbus TCP/IP Option Registers

All of the command registers, monitor registers, and parameters documented in the drive Technical Manual are accessible via the option.

■ High Speed Access Drive Modbus TCP/IP Option Registers

Many of the registers required for control have been specially mapped to provide higher speed access to increase network performance. Use these registers for the best response times.

All of the drive command registers have been mapped to this high speed access area (Modbus TCP/IP registers 01H to 01FH). In addition, the monitors shown in [Table 9](#) are mapped for high speed access.

Note: The Modbus TCP/IP register is different for different product series. Refer to the instruction manual of a specific drive for more information.

Table 9 Drive Registers

Address (hex)	Drive Register (hex)	Description	Bit	Description
2000	4B	Status Word (U1-12)	0	During Run
			1	During Zero Speed
			2	During Reverse Direction
			3	During Fault Reset Signal Input
			4	During Speed Agree
			5	Drive Ready
			6	Alarm
			7	Fault
			8	During Operation Error (oPE□□)
			9	During Momentary Power Loss
			A	Motor 2 Selected
			B	Reserved
			C	Reserved
			D	Reserved
			E	ComRef Status, NetRef Status
F	ComCtrl Status, NetCtrl Status			
2001	44	Motor Speed Monitor (U1-05)		
2002	48	Torque Reference Monitor (U1-09)		
2003	F0	PG Count Channel 1		
2004	40	Frequency Reference Monitor (U1-01)		
2005	41	Output Frequency Monitor (U1-02)		
2006	26	Output Current (U1-03) (0.1 A units)		
2007	4F	Terminal A2 Input Level Monitor (U1-14)		
2008	46	DC Bus Voltage Monitor (U1-07)		

7 Modbus TCP/IP Messaging

Address (hex)	Drive Register (hex)	Description	Bit	Description
2009	C0	Error Signal 1	0	Reserved
			1	Undervoltage (Uv1)
			2	Control Power Supply Undervoltage (Uv2)
			3	Soft Charge Circuit Fault (Uv3)
			4	Short Circuit / IGBT Failure (SC)
			5	Ground Fault (GF)
			6	Overcurrent (oC)
			7	Overvoltage (ov)
			8	Heatsink Overheat (oH)
			9	Heatsink Overheat (oH1)
			A	Motor Overload (oL1)
			B	Drive Overload (oL2)
			C	Overtorque Detection 1 (oL3)
			D	Overtorque Detection 2 (oL4)
			E	Dynamic Braking Transistor Fault (rr)
			F	Braking Resister Overheat (rH)
200A	C1	Error Signal 2	0	External Fault at input terminal S3 (EF3)
			1	External Fault at input terminal S4 (EF4)
			2	External Fault at input terminal S5 (EF5)
			3	External Fault at input terminal S6 (EF6)
			4	External Fault at input terminal S7 (EF7)
			5	External Fault at input terminal S8 (EF8)
			6	Cooling fan Error (FAn)
			7	Overspeed (os)
			8	Excessive Speed Deviation (dEv)
			9	PG Disconnected (PGo)
			A	Input Phase Loss (PF)
			B	Output Phase Loss (LF)
			C	Motor Overheat (PTC input) (oH3)
			D	Keypad Connection Fault (oPr)
			E	EEPROM Write Error (Err)
			F	Motor Overheat Fault (PTC input) (oH4)

7 Modbus TCP/IP Messaging

Address (hex)	Drive Register (hex)	Description	Bit	Description
200B	C2	Error Signal 3	0	MEMOBUS/Modbus Communication Error (CE)
			1	Option Communication Error (bUS)
			2	Reserved
			3	Reserved
			4	Control Fault (CF)
			5	Zero Servo Fault (SvE)
			6	Option External Fault (EF0)
			7	PID Feedback Loss (FbL)
			8	Undertorque Detection 1 (UL3)
			9	UL4 Undertorque Detection 2 (UL4)
			A	High Slip Braking Overload (oL7)
			B	Reserved
			C	Reserved
			D	Reserved
			E	Reserved
F	Hardware Fault (includes oF□)			
200C	4E	Terminal A1 Input Level Monitor (U1-13)		
200D	49	Digital Input Terminal Status (U1-10)		
200E	50	Terminal A3 Input Level Monitor (U1-15)		
200F	F1	PG Count Channel 2		
2010	4D	Drive Software Number (Flash) (U1-25)		

7 Modbus TCP/IP Messaging

◆ Enter Command Types

The drive supports two types of Enter Commands as shown in the table below. An Enter Command is enabled by writing 0 to register number 0900H or 0910H.

■ Enter Commands

Table 10 Enter Command Types

Register Number	Description
0900H	Writes data into the EEPROM (non-volatile memory) of the drive and enables the data to RAM at the same time. Parameter changes remain even if the power supply is cycled.
0910H	Writes data in the RAM only. Parameter changes are lost when the drive is shut off.

Note: Because the EEPROM can be written to a maximum of 100,000 times, refrain from frequently writing to the EEPROM. An Enter Command is not required if reference or broadcast data are sent to the drive.

◆ Enter Command Settings

When replacing earlier Yaskawa drive models with a 1000 Series drive and keeping the MEMOBUS/Modbus communications settings, parameter H5-11 needs to be set in accordance with how the Enter Command functions in the older drive. H5-11 determines if an Enter Command is needed or not in order to activate parameter changes in the drive.

- If upgrading from a G7 or F7 series drive to 1000 Series, set parameter H5-11 to 0.
- If upgrading from a V7 series drive to 1000 Series, set parameter H5-11 to 1.

■ H5-11 and the Enter Commands

Table 11 Enter Command Types

H5-11 Settings	H5-11 = 0	H5-11 = 1
Drive being replaced.	G7, F7	V7
How parameter settings are enabled.	When the Enter Command is received from the master.	As soon as the value is changed.
Upper/lower limit check.	Upper/lower limit check is performed taking the settings of related parameters into account.	The upper/lower limit of the changed parameter is checked only.
Default value of related parameters.	Not affected. The settings of related parameters remain unchanged. Parameters must be changed manually if needed.	The default settings of related parameters are changed automatically.
Error handling when setting multiple parameters.	Data is accepted even if one setting is invalid. The invalid setting will be discarded. No error message occurs.	Error occurs if only one setting is invalid. All data sent is discarded.

8 Web Interface

The web server interface to the drive option allows management of diagnostic information through a standard web browser. The embedded web pages include:

- Home page (Status, Faults, and Information)
- Modbus-TCP page (Protocol Monitor)
- Network page (Network Monitor)

◆ Home Page (Status, Faults, and Information)

The Home page shows the status of the drive and the I/O. It also shows identifying information about the drive and the option card.

The screenshot displays the Yaskawa web interface for a CIMR-AU2A0004 Modbus-TCP / SI-EM3 drive. The interface is organized into several sections:

- Header:** YASKAWA logo on the left, and CIMR-AU2A0004 Modbus-TCP / SI-EM3 on the right.
- Navigation:** Home, Modbus-TCP, and Network tabs.
- Drive Status:** Shows 'Ready' status with a row of control buttons: RUN, ZERO SPD (highlighted in green), REV, RESET, AT SPD, READY (highlighted in green), ALARM, and FAULT.
- Drive Monitors:**

Frequency Reference	0.00 Hz
Output Frequency	0.00 Hz
Output Current	0.0 A
DC Bus Voltage	336 VDC
Torque Reference	0.0 %
- Digital Inputs:** A vertical list of 8 inputs (S1-S8), each with a grey square indicator.
- Digital Outputs:** A vertical list of 3 outputs (M1-M2, M3-M4, M5-M6). M3-M4 is highlighted in green.
- Analog Inputs:** A vertical list of 3 inputs (A1, A2, A3), each with a grey slider and a value of 0.0 %.
- Drive Information:**

Model	A1000
Full Model	CIMR-AU2A0004
Version	1024
- Option Card Information:**

Model	SI-EM3
Version	VST908104 (R0)
Protocol	Modbus-TCP
- Footer:** ©2018 Yaskawa America, Inc. All Rights Reserved - WEB 421 (R0) on the left, and Update Time: 1 sec on the right.

Figure 24 Home Page View

8 Web Interface

◆ Modbus-TCP Page (Protocol Monitor)

The Modbus-TCP page shows basic information about the protocol.

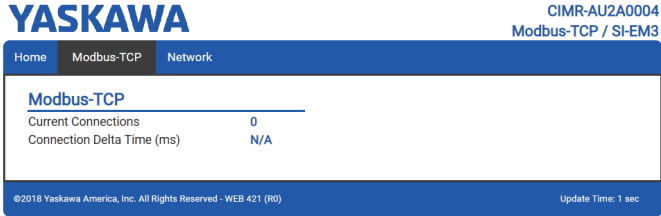

Figure 25 Modbus-TCP Page View

Table 12 Protocol Monitor Explanations

Protocol Monitor	Explanation
Current Connections	Current number of open connections.
Control Connection Delta Time	The time between the last two writes to the Control register, MEMOBUS/Modbus address 0001H.

◆ Network page (Network Monitor)

The embedded network monitor page shows the status of the option network traffic and open I/O connections.

YASKAWA CIMR-AU2A0004
Modbus-TCP / SI-EM3

Home Modbus-TCP **Network**

Identity		Packet Counters		Tx	Rx
IP Address	192.168.1.23	Ok		76325	95615
Subnet Mask	255.255.255.0	Errors		0	0
Gateway Address	192.168.1.1	Dropped		0	0
MAC Address	00:20:B5:88:56:F7	Interface Counters			
Address Mode	Static	In Octets			13222832
Status		In Ucast Packets			94923
Link Status	Active	In NUcast Packets			3631
Speed	100 Mbps	Out Octets			10827669
Duplex	Full	Out Ucast Packets			76216
Auto-Negotiation	Successful	Out NUcast Packets			47
Misc		Media Counters			
Retry	0	Alignment Errors			0
Collisions	0	FCS Errors			0
Current Connections	0	Single Collisions			0
		Multiple Collisions			0
		Late Collisions			0
		Deferred Collisions			0
		Excessive Collisions			0
		Frame Too Large			0

©2018 Yaskawa America, Inc. All Rights Reserved - WEB 421 (R0) Update Time: 1 sec

Figure 26 Network Page View

Table 13 Network Monitor Explanations

Network Monitor	Explanation
Msg Tx OK	Cumulative number of messages transmit successfully from the option.
Msg Rx OK	Cumulative number of messages received successfully to the option.
Current Connections	Current number of open connections.
Msg Tx Dropped	Cumulative number of messages dropped due to output network buffer being full and unable to hold the new message.
Msg Rx Dropped	Cumulative number of messages dropped due to input network buffer being full and unable to hold the new message.
Collisions	Cumulative number of collisions (half duplex only) reported by the MAC/PHY (Media Access Control/Physical Connection).
Msg Tx Errors	Cumulative number of transmit underruns and transmit stops reported by the MAC/PHY.

8 Web Interface

Network Monitor	Explanation
Msg Rx Errors	Cumulative number of receive overruns, receive stops, and receive error frames reported by the MAC/PHY.
Tx Retry	Cumulative number of transmits in which the 1st attempt was delayed due to busy medium reported by the MAC/PHY.
IP Address	IP Address of the option card.
Subnet Mask	Subnet Mask of the option card.
Gateway Address	The Gateway IP Address that the option card will use.
MAC Address	MAC Address of the option card.
Address Mode	Either static IP address or DHCP.
Link Status	Active if the cable is plugged in, or inactive if no cable.
Speed	Connection speed, either 10 Mbps or 100 Mbps.
Duplex	Display either Full or Half.
Auto-Negotiation	If auto-negotiation is enabled, this will show the status of the negotiation.
In Octets	Cumulative number of incoming octets.
In Ucast Packets	Cumulative number of unicast packets received.
In NUcast Packets	Cumulative number of non-unicast packets received.
Out Octets	Cumulative number of outgoing octets.
Out Ucast Packets	Cumulative number of unicast packets sent.
Out NUcast Packets	Cumulative number of non-unicast packets sent.
Alignment Errors	Cumulative number of errors for uneven packets lengths.
FCS Errors	Cumulative number of frame check sequence errors.
Single Collisions	Cumulative number of single collisions.
Multiple Collisions	Cumulative number of multiple collisions.
Late Collisions	Cumulative number of late collisions.
Deferred Collisions	Cumulative number of deferred collisions.
Excessive Collisions	Cumulative number of excessive collisions.
Frame Too Large	Cumulative number of frames that exceed the maximum frame size.

Note: Cumulative counters are reset when the power supply is cycled.

9 Troubleshooting

◆ Drive-Side Error Codes

Drive-side error codes appear on the drive keypad. *Table 14* lists causes of the errors and possible corrective actions. Refer to the drive Technical Manual for additional error codes that may appear on the drive keypad.

■ Faults

Both bUS (Option communication error) and EF0 (Option Card External Fault) can appear as an alarm or as a fault. When a fault occurs, the keypad ALM LED remains lit. When an alarm occurs, the ALM LED flashes.

If communication stops while the drive is running, use the following questions as a guide to help remedy the fault:





- Is the option properly installed?
- Is the communication line properly connected to the option? Is it loose?
- Is the controller program working? Has the controller/PLC CPU stopped?
- Did a momentary power loss interrupt communications?

Table 14 Fault Displays, Causes, and Possible Solutions

Keypad Display		Fault Name
<i>bUS</i>	bUS	Option Communication Error.
		<ul style="list-style-type: none"> • After establishing initial communication, the connection was lost. • Only detected when the run command or frequency reference is assigned to the option (b1-01 = 3 or b1-02 = 3).
Cause		Possible Solutions
No signal was received from the PLC.		<ul style="list-style-type: none"> • Check for faulty wiring. • Correct any wiring problems.
Faulty communications wiring		
An existing short circuit or communications disconnection		Check disconnected cables and short circuits and repair as needed.
A data error occurred due to electric interference.		<ul style="list-style-type: none"> • Counteract noise in the control circuit, main circuit, and ground wiring. • If a magnetic contactor is identified as a source of noise, install a surge absorber to the contactor coil. • Use only recommended cables or other shielded line. Ground the shield on the controller side or the drive input power side. • Separate all communication wiring from drive power lines. Install an EMC noise filter to the drive power supply input. • Counteract noise in the master controller (PLC).

9 Troubleshooting

The option is not properly connected to the drive.		Reinstall the option.
Option is damaged		If there are no problems with the wiring and the error continues to occur, replace the option.
Control Connection Timeout		The control connection timer value set in F7-16 has timed out.
Duplicate IP Address		The option shares IP Address with at least one other node. Check the setting value of F7-03 and F7-04 (IP Address).
Keypad Display		Fault Name
EFO	EF0	Option Card External Fault
		The alarm function for an external device has been triggered.
Cause		Possible Solutions
An external fault was received from the PLC.		<ol style="list-style-type: none"> 1. Remove the cause of the external fault. 2. Reset the external fault input from the PLC.
Problem with the PLC program		Check the PLC program.
PLC is in the Idle Mode.		<ol style="list-style-type: none"> 1. Set the PLC to the Run Mode. 2. Set the parameter F6-54 = 0 (Enabled) to ignore errors while the PLC is in the Idle Mode.
Keypad Display		Fault Name
oFA00	oFA00	Option Card Connection Error (CN5-A)
		Option is not properly connected.
Cause		Possible Solutions
The option card installed into port CN5-A is incompatible with the drive.		Connect the option to the correct option port. Note: PG option cards are supported by option ports CN5-B and CN5-C only.
Keypad Display		Fault Name
oFA01	oFA01	Option Card Fault (CN5-A)
		Option is not properly connected.
Cause		Possible Solutions
The option connected to option port CN5-A was changed during run.		De-energize the drive and plug the option into the drive according to Installation Procedure on page 17 .
Keypad Display		Fault Name
oFA03, oFA04	oFA03,	Option Card Error (CN5-A)
	oFA04	Option Card Error (CN5-A)
Cause		Possible Solutions
A fault occurred in the option.		<ol style="list-style-type: none"> 1. De-energize the drive. 2. Make sure that the option is correctly connected to the connector. 3. If the problem continues, replace the option.

Keypad Display		Fault Name
	oFA30 to oFA43	Option Card Connection Error (CN5-A)
		Communication ID error.
Cause		Possible Solutions
The option card connection to port CN5-A is faulty.		<ol style="list-style-type: none"> 1. Turn off the power. 2. Check if the option is properly plugged into the option port. 3. Replace the option if the fault continues to occur.
Keypad Display		Fault Name
	oFb00	Option Fault (CN5-B)
		Non-compatible option is connected.
Cause		Possible Solutions
The option card installed into port CN5-B is incompatible with the drive.		Connect the option to the correct option port. Note: Use connector CN5-B when connecting DO-A3, AO-A3, or two PG options. Use connector CN5-C when connecting only one PG option.
Keypad Display		Fault Name
	oFb02	Option Fault (CN5-B)
		Two identical options are connected at the same time.
Cause		Possible Solutions
An option of the same type is already installed in option port CN5-A, CN5-B, or CN5-C.		Connect the option to the correct option port.
Keypad Display		Fault Name
	oFC00	Option Fault (CN5-C)
		Non-compatible option is connected.
Cause		Possible Solutions
The option card installed into port CN5-C is incompatible with the drive.		Connect the option to the correct option port. Note: AI-A3, DI-A3, and communication options are not supported by option port CN5-C.
Keypad Display		Fault Name
	oFC02	Option Fault
		Option Flash write mode.
Cause		Possible Solutions
An option of the same type is already installed in option port CN5-A, CN5-B, or CN5-C.		Connect the option to the correct option port.

9 Troubleshooting

■ Minor Faults and Alarms

Keypad Display		Minor Fault Name	
[YP0]	CyPo	Cycle Power to Active Parameters	
		Comm. Option Parameter Not Upgraded	
Cause		Possible Solutions	Minor Fault (H2-□□ = 10)
Although F6-15 = 1 [Comm. Option Parameters Reload = Reload Now], the drive does not update the communication option parameters.		Re-energize the drive to update the communication option parameters. Note: If the option software version is not compatible or if you install an incorrect option to the drive, it will trigger an alarm.	YES

■ Option Fault Monitors U6-98 and U6-99

The option can declare error/warning conditions via drive monitor parameters on the drive keypad as shown in [Table 15](#).

Table 15 Option Fault Monitor Descriptions

Fault Condition	Fault Declared	Status Value (U6-98/U6-99)	Description
No Fault	n/a	0	No faults
Force Fault	EF0	3	Network sent a message to force this node to the fault state
Network Link Down	BUS ERROR	1200	No network link to the option
Connection Time-out	BUS ERROR	1201	The control connection timer (F7-16) timed out
Duplicate IP Address	BUS ERROR	1202	This node and at least one other node have the same IP address
Default MAC Address	None	1203	Factory default MAC Address programmed into the option. Contact Yaskawa or a Yaskawa representative for details.

Two drive monitor parameters, U6-98 and U6-99, assist the user in network troubleshooting.

- U6-98 displays the first declared fault since the last power cycle. U6-98 is only cleared upon drive power-up.
- U6-99 displays the present option status. U6-99 is cleared upon a network-issued fault reset and upon power-up.

If another fault occurs while the original fault is still active, parameter U6-98 retains the original fault value and U6-99 stores the new fault status value.

◆ Option Compatibility

Users may connect up to 3 options simultaneously depending on the type of option. Refer to [Table 16](#) for details.

Table 16 Option Compatibility

Option Card	Connector	Number of Cards Possible
PG-B3, PG-X3	CN5-B, C	2 <1>
PG-RT3 <2> <3>, PG-F3 <2> <3>	CN5-C	1
DO-A3, AO-A3	CN5-A, B, C	1
SI-C3, SI-N3, SI-P3, SI-S3, SI-T3, SI-ET3, SI-ES3, SI-B3, SI-M3, SI-W3 <4>, SI-EM3 <3>, SI-EN3 <3>, SI-EP3, AI-A3 <4>, DI-A3 <4>, SI-EN3D, SI-EM3D	CN5-A	1

- <1> When connecting two PG option cards, use both CN5-B and CN5-C. When connecting only one PG option card, use the CN5-C connector.
- <2> Not available for the application with Motor 2 Selection.
- <3> Not available with 1000-Series drive models with a capacities between 450 and 630 kW.
- <4> When you use the input status of AI-A3 and DI-A3 as a monitor, you can connect AI-A3 and DI-A3 to CN5-A, CN5-B, or CN5-C.

10 Option Installation

Verify the following installation conditions to suppress the radiated emissions from other devices and machinery used in combination with this option and drives:

1. Use dedicated shield cable for the option and external device (encoder, I/O device, master), or run the wiring through a metal conduit.
2. Keep wiring as short as possible and ground the largest possible surface area of the shield to the metal panel according to [Figure 28](#).

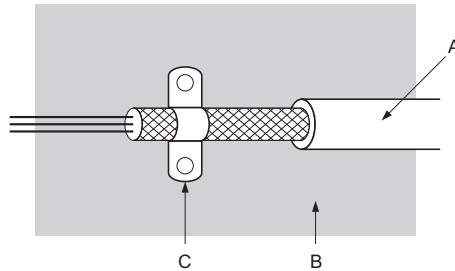

A – Braided shield cable

C – Cable clamp (conductive)

B – Metal panel

Figure 27 Ground Area

■ Option Installation: Models PG-□□, DI-□□, DO-□□, AI-□□, AO-□□, SI-□□

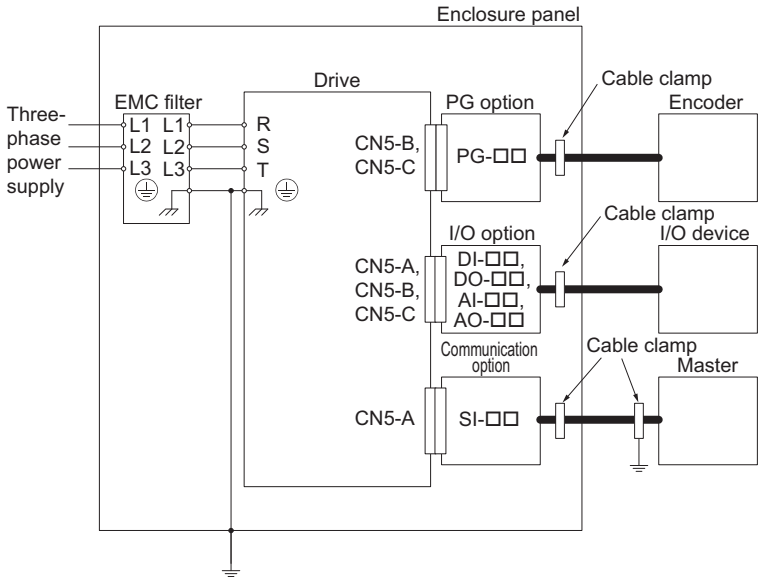

Figure 28 Option Installation (PG-□□, DI-□□, DO-□□, AI-□□, AO-□□, SI□□)

11 Specifications

Table 17 Option Specifications

Item	Specifications
Model	SI-EM3
Supported Messages	<ul style="list-style-type: none"> • Read Multiple Registers (03H) • Write Single Register (06H) • Write Multiple Registers (10H) • Read and Write Registers (17H) Commands that support multiple registers have a maximum Read and Write size of 16 registers.
Option Conformance	Modbus-IDA Passed
Connector Type	RJ45 8-pin Shielded Twisted Pair Cat 5e cable
Physical Layer Type	Isolated Physical Layer
IP Address Setting	Programmable from drive keypad or network
Communication Speed	Programmable from drive keypad or network: 10/100 Mbps, auto-negotiate.
Number of Connections	Modbus TCP/IP: 10 Web Page Access: 2
Duplex Mode	Half-forced, Auto-negotiate, Full-forced
Address Startup Mode	Static, BOOTP, DHCP
Ambient Temperature	-10 °C to +50 °C (14 °F to 122 °F)
Humidity	95% RH or lower with no condensation
Storage Temperature	-20 °C to +60 °C (-4 °F to 140 °F) allowed for short-term transport of the product
Area of Use	Indoors and free from: <ul style="list-style-type: none"> • Oil mist, corrosive gas, flammable gas, and dust • Radioactive materials or flammable materials, including wood • Harmful gas or fluids • Salt • Direct sunlight • Falling foreign objects
Altitude	1000 m (3280 ft) or lower

◆ Revision History

Revision dates and manual numbers appear on the bottom of the back cover.

MANUAL NO.

TOBP C730600 91B <1>

Revision number

Published in Japan July 2017

Date of publication

Date of Publication	Revision Number	Section	Revised Content
January 2019	<2>	All	Addition: Applicable product series Revision: Reviewed and corrected entire documentation.
		Back cover	Revision: Address
July 2017	<1>	Chapter 2	Addition: Note in Table 1
		Back cover	Revision: Address
May 2016	–	–	First edition

YASKAWA AC Drive Option Modbus TCP/IP Installation Manual

DRIVE CENTER (INVERTER PLANT)

2-13-1, Nishimiyaichi, Yukuhashi, Fukuoka, 824-8511, Japan
Phone: +81-930-25-2549 Fax: +81-930-25-3431
<http://www.yaskawa.co.jp>

YASKAWA ELECTRIC CORPORATION

New Pier Takeshiba South Tower, 1-16-1, Kaigan, Minato-ku, Tokyo, 105-6891, Japan
Phone: +81-3-5402-4502 Fax: +81-3-5402-4580
<http://www.yaskawa.co.jp>

YASKAWA AMERICA, INC.

2121, Norman Drive South, Waukegan, IL 60085, U.S.A.
Phone: +1-800-YASKAWA (927-5292) or +1-847-887-7000 Fax: +1-847-887-7310
<http://www.yaskawa.com>

YASKAWA ELÉTRICO DO BRASIL LTDA.

777, Avenida Piraporinha, Diadema, São Paulo, 09950-000, Brasil
Phone: +55-11-3585-1100 Fax: +55-11-3585-1187
<http://www.yaskawa.com.br>

YASKAWA EUROPE GmbH

Hauptstraße 185, 65760 Eschborn, Germany
Phone: +49-6196-569-300 Fax: +49-6196-569-398
<http://www.yaskawa.eu.com> E-mail: info@yaskawa.eu.com

YASKAWA ELECTRIC KOREA CORPORATION

35F, Three IFC, 10 Gukjegeumjung-ro, Yeongdeungpo-gu, Seoul, 07326, Korea
Phone: +82-2-784-7944 Fax: +82-2-784-9465
<http://www.yaskawa.co.kr>

YASKAWA ASIA PACIFIC PTE. LTD.

30A, Kallang Place, #06-01, 339213, Singapore
Phone: +65-6282-3003 Fax: +65-6289-3003
<http://www.yaskawa.com.sg>

YASKAWA ELECTRIC (THAILAND) CO., LTD.

59, 1st-5th Floor, Flourish Building, Soi Ratchadapisek 18, Ratchadapisek Road, Huaykwang, Bangkok, 10310, Thailand
Phone: +66-2-017-0099 Fax: +66-2-017-0799
<http://www.yaskawa.co.th>

YASKAWA ELECTRIC (CHINA) CO., LTD.

22F Link Square 1, No.222, Hubin Road, Shanghai, 200021, China
Phone: +86-21-5385-2200 Fax: +86-21-5385-3299
<http://www.yaskawa.com.cn>

YASKAWA ELECTRIC (CHINA) CO., LTD. BEIJING OFFICE

Room 1011, Tower W3 Oriental Plaza, No. 1, East Chang An Ave.,
Dong Cheng District, Beijing, 100738, China
Phone: +86-10-8518-4086 Fax: +86-10-8518-4082

YASKAWA ELECTRIC TAIWAN CORPORATION

12F, No.207, Sec. 3, Beishin Rd., Shindian Dist., New Taipei City 23143, Taiwan
Phone: +886-2-8913-1333 Fax: +886-2-8913-1513 or +886-2-8913-1519
<http://www.yaskawa.com.tw>

YASKAWA INDIA PRIVATE LIMITED

#17/A, Electronics City, Hosur Road, Bangalore, 560 100 (Karnataka), India
Phone: +91-80-4244-1900 Fax: +91-80-4244-1901
<http://www.yaskawaindia.in>

YASKAWA

YASKAWA ELECTRIC CORPORATION

In the event that the end user of this product is to be the military and said product is to be employed in any weapons systems or the manufacture thereof, the export will fall under the relevant regulations as stipulated in the Foreign Exchange and Foreign Trade Regulations. Therefore, be sure to follow all procedures and submit all relevant documentation according to any and all rules, regulations and laws that may apply.

Specifications are subject to change without notice for ongoing product modifications and improvements.

© 2016 YASKAWA ELECTRIC CORPORATION

MANUAL NO.

TOBP C730600 91C <2>-0

Published in Japan January 2019

18-11-20