

YASKAWA AC Drive 1000-Series Option PROFIBUS-DP Installation Manual

Type: SI-P3

To properly use the product, read this manual thoroughly and retain for easy reference, inspection, and maintenance. Ensure the end user receives this manual.

安川インバータ 1000シリーズ オプション PROFIBUS-DP通信 取扱説明書

形 式 SI-P3

製品を安全にお使い頂くために、この取扱説明書を必ずお読みください。
また、本書をお手元に保管していただくとともに、最終的に本製品をご使用になるユーザー様のお手元に確実に届けられるよう、お取り計らい願います。

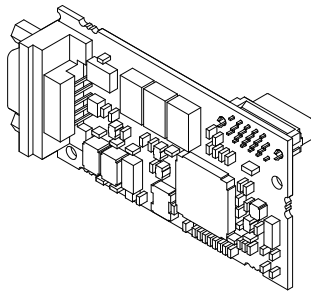

Copyright © 2008 YASKAWA ELECTRIC CORPORATION

All rights reserved. No part of this publication may be reproduced, stored in a retrieval system, or transmitted, in any form or by any means, mechanical, electronic, photocopying, recording, or otherwise, without the prior written permission of Yaskawa. No patent liability is assumed with respect to the use of the information contained herein. Moreover, because Yaskawa is constantly striving to improve its high-quality products, the information contained in this manual is subject to change without notice. Every precaution has been taken in the preparation of this manual. Yaskawa assumes no responsibility for errors or omissions. Neither is any liability assumed for damages resulting from the use of the information contained in this publication.



Table of Contents

1 PREFACE AND SAFETY	4
2 PRODUCT OVERVIEW	8
3 RECEIVING	9
4 OPTION COMPONENTS	10
5 INSTALLATION PROCEDURE	13
6 RELATED PARAMETERS	24
7 OPTION DATA AND I/O MAPS	26
8 TROUBLESHOOTING	30
9 SPECIFICATIONS	33

1 Preface and Safety

Yaskawa manufactures products used as components in a wide variety of industrial systems and equipment. The selection and application of Yaskawa products remain the responsibility of the equipment manufacturer or end user. Yaskawa accepts no responsibility for the way its products are incorporated into the final system design. Under no circumstances should any Yaskawa product be incorporated into any product or design as the exclusive or sole safety control. Without exception, all controls should be designed to detect faults dynamically and fail safely under all circumstances. All systems or equipment designed to incorporate a product manufactured by Yaskawa must be supplied to the end user with appropriate warnings and instructions as to the safe use and operation of that part. Any warnings provided by Yaskawa must be promptly provided to the end user. Yaskawa offers an express warranty only as to the quality of its products in conforming to standards and specifications published in the Yaskawa manual. **NO OTHER WARRANTY, EXPRESS OR IMPLIED, IS OFFERED.** Yaskawa assumes no liability for any personal injury, property damage, losses, or claims arising from misapplication of its products.

◆ Applicable Documentation

The following manuals are available for the option:

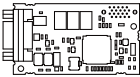
		Option
	<p>Yaskawa AC Drive 1000-Series Option PROFIBUS-DP Installation Manual Manual No: TOBPC73060042</p>	<p>Read this manual first. The installation manual is packaged with the option and contains information required to install the option and set up related drive parameters.</p>
	<p>Yaskawa AC Drive 1000-Series Option PROFIBUS-DP Technical Manual Manual No: SIEPC73060042</p>	<p>The technical manual contains detailed information about the option. Access the following sites to obtain the technical manual: U.S.: http://www.yaskawa.com Europe: http://www.yaskawa.eu.com Japan: http://www.e-mechatronics.com Other areas: Contact a Yaskawa representative.</p>

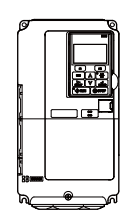
		Yaskawa Drive
	<p>Yaskawa AC Drive 1000-Series Quick Start Guide</p>	<p>The drive manuals cover basic installation, wiring, operation procedures, functions, troubleshooting, and maintenance information. The manuals also include important information about parameter settings and drive tuning. Access these sites to obtain Yaskawa instruction manuals: U.S.: http://www.yaskawa.com Europe: http://www.yaskawa.eu.com Japan: http://www.e-mechatronics.com Other areas: Contact a Yaskawa representative.</p>
	<p>Yaskawa AC Drive 1000-Series Technical Manual</p>	

◆ Terms and Abbreviations

Note:	Indicates a supplement or precaution that does not cause drive damage.
Drive:	Yaskawa AC Drive 1000-Series
Option:	Yaskawa AC Drive 1000-Series Option PROFIBUS-DP SI-P3
V/f:	V/f Control
CLV:	Closed Loop Vector Control
OLV/PM:	Open Loop Vector Control for PM
AOLV/PM:	Advanced Open Loop Vector Control for PM
CLV/PM:	Closed Loop Vector Control for PM

◆ Registered Trademarks

- PROFIBUS-DP is a registered trademark of PROFIBUS International.
- Trademarks are the property of their respective owners.

◆ Supplemental Safety Information

Read and understand this manual before installing, operating, or servicing this option. Install the option according to this manual and local codes.

The following conventions indicate safety messages in this manual. Failure to heed these messages could cause fatal injury or damage products and related equipment and systems.

DANGER

Indicates a hazardous situation, which, if not avoided, will result in death or serious injury.

WARNING

Indicates a hazardous situation, which, if not avoided, could result in death or serious injury.

1 Preface and Safety

CAUTION

Indicates a hazardous situation, which, if not avoided, could result in minor or moderate injury.

NOTICE

Indicates an equipment damage message.

■ General Safety

General Precautions

- The diagrams in this book may include options and drives without covers or safety shields to illustrate details. Be sure to reinstall covers or shields before operating any devices. Use the option according to the instructions described in this manual.
- Any illustrations, photographs, or examples used in this manual are provided as examples only and may not apply to all products to which this manual is applicable.
- The products and specifications described in this manual or the content and presentation of the manual may be changed without notice to improve the product and/or the manual.
- When ordering new copies of the manual, contact a Yaskawa representative or the nearest Yaskawa sales office and provide the manual number shown on the front cover.

DANGER

Heed the safety messages in this manual.

Failure to comply will result in death or serious injury.

The operating company is responsible for any injuries or equipment damage resulting from failure to heed the warnings in this manual.

NOTICE

Do not modify the drive or option circuitry.

Failure to comply could result in damage to the drive or option and will void warranty. Yaskawa is not responsible for any modification of the product made by the user. This product must not be modified.

Do not expose the drive or option to halogen group disinfectants.

Failure to comply may cause damage to the electrical components in the option.

Do not pack the drive in wooden materials that have been fumigated or sterilized.

Do not sterilize the entire package after the product is packed.

2 Product Overview

◆ About This Product

The SI-P3 PROFIBUS-DP Option is an open digital communication system supporting a wide range of fast, time-critical applications.

PROFIBUS Decentral Periphery (PROFIBUS-DP) is one of the three PROFIBUS variants. DP is dedicated to fast data communication between systems and peripherals at a field level. This option connects a Yaskawa drive to a field network using the PROFIBUS-DP protocol.

PROFIBUS-DP is included into the European Fieldbus Standard EN 50170.

The network is primarily used in process and factory automation.

Installing the option to a Yaskawa drive allows a PROFIBUS-DP master device to:

- operate the drive
- monitor the operation status of the drive
- change parameter settings.

◆ Applicable Models

The option can be used with the models in [Table 1](#).

Table 1 Applicable Models

Drive Series	Drive Model Number
A1000	All models





3 Receiving

Please perform the following tasks upon receiving the option:

- Inspect the option for damage. Contact the shipper immediately if the option appears damaged upon receipt.
- Verify receipt of the correct model by checking the model number printed on the option nameplate (Refer to *Figure 1* on page 10).
- Contact your supplier if you have received the wrong model or the option does not function properly.

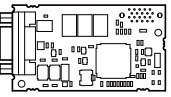
◆ Contents and Packaging

Table 2 Contents of Package

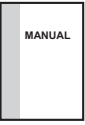
Description:	Option	Ground Wire	Screws (M3)	LED Label	Installation Manual
					
Quantity:	1	1	3	1	1

◆ Tools Required for Installation

- A Phillips screwdriver (M3 metric / #1, #2 U.S. standard size) is required to install the option.
- A pair of diagonal cutting pliers.
- A small file or medium-grit sandpaper.

Note: Tools required to prepare option cables for wiring are not listed in this manual.

4 Option Components

◆ PROFIBUS-DP SI-P3 Option

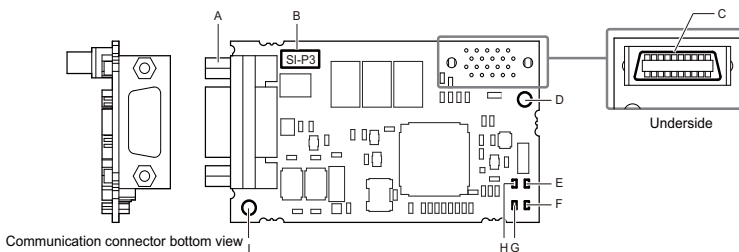

A – Communication connector

B – Model number

C – Connector (CN5)

D – Installation hole

E – LED (RUN) <1>

F – LED (COMM) <1>

G – LED (BF) <1>

H – LED (ERR) <1>

I – Ground terminal and installation hole <2>

<1> Refer to [Option LED Display on page 11](#) for details on the LEDs.

<2> The ground wire provided in the option shipping package must be connected during installation.

Figure 1 PROFIBUS-DP Option Components

◆ Communication Connector

The option has a 9-pin D-sub connector to connect to a PROFIBUS network.

Table 3 Communication Connector (9-pin D-sub)

Connector	Pin	Signal	Description
	1	Shield	Connected to the metal-shell (no direct FG-connection)
	2	–	–
	3	RxD/TxD-P	Receive/Transmit data; line B (red)
	4	CNTR-P	Control signal for repeaters (direction control)
	5	DGND	Data ground (reference voltage to VP)
	6	VP	Power supply output for bus termination (for termination resistor)
	7	–	–
	8	RxD/TxD-N	Receive/Transmit data; line A (green)
	9	–	–

◆ Option LED Display

The option has four bicolor, red/green LEDs to relay information about power, communication status, and errors.

The operational states of the LEDs after completion of the power-up diagnostic process are described in [Table 5](#). Wait at least 2 seconds for the power-up diagnostic process to complete before verifying the states of the LEDs.

Table 4 Option LED States

LED	Display		Operating Status	Remarks
	Color	Status		
RUN (Power)	Green	ON	Power supply ON	Power is supplied to the option, and the option hardware self-diagnostics check is complete.
		OFF	Power supply OFF	<ul style="list-style-type: none"> The drive has no power supply. Option and drive are not connected properly and/or no power is supplied to the option. An internal, self-diagnostic error occurred in the option.
ERR (Option Error)	Red	ON	Option error	Self-diagnostics error occurred in the option.
		Flashing	Drive connection error	Connection error between option and drive. This includes node address setting errors to parameter F6-30 on the drive side.
		OFF	Normal operation	Drive and option are properly connected.
COMM (Communication Status)	Green	ON	Communication connected	Normal send/receive between the option and the PROFIBUS-DP master.
		OFF	No data exchange	There is a problem establishing communication between the option and the PROFIBUS-DP master.
BF (PROFIBUS-DP Error)	Red	ON	Waiting for communication procedure setting	Communication-related parameters are in the process of being set or initialized by the PROFIBUS-DP master.
		Flashing	Communication setting error	Communication parameter error from PROFIBUS-DP master.
		OFF	Normal operation	LED shuts off when the PROFIBUS-DP master is finished setting communication-related parameters.

4 Option Components

Table 5 LED Operation After Power-up Diagnostic

LED				Communication Status	Possible Cause	Solution
RUN	ERR	COMM	BF			
●	●	●	●	No power	<ul style="list-style-type: none"> Drive has no power. Option is not properly connected to the drive or is not receiving enough power. 	<ul style="list-style-type: none"> Check all wiring to the drive, then turn on the power. Shut off the drive and make sure the option is connected properly. Turn the power back on.
○	●	●	●	<ul style="list-style-type: none"> Checking connection with the drive Waiting for data from the master 	<ul style="list-style-type: none"> Option is reading the node address or parameter configuration. Waiting for initial input data from master device. 	—
●	○	●	●	Option self-diagnostics error	The option is damaged.	Cycle power to the drive. If the LED status does not change, replace the option.
●	◐	●	●	Problem connecting to the drive	<ul style="list-style-type: none"> Problem initializing the drive and the option. Incorrect node address. 	<ul style="list-style-type: none"> Cycle power to the drive. If the LED status does not change, replace the option. Check the node address setting in the drive (F6-10).
○	●	●	○	Waiting for data from the master device	Waiting for data from the master device. (Set_Parm_Message or Chk_Cfg_Message)	<ul style="list-style-type: none"> Check master network settings. Make sure the master device is operating normally. Check the terminal resistance settings on the data line. Check for problems with the data line and connector. Check if the data line is connected properly to communication connector CN5.
○	●	●	◐	Incorrect data or option time out waiting for data	The communication settings in the master are set incorrectly.	Check the communication settings in the master.
○	●	○	●	Sending or receiving data	—	—

○: On / ◐ : Flashing / ●: Off

5 Installation Procedure

◆ Section Safety

DANGER

Electric Shock Hazard

Do not connect or disconnect wiring while the power is on.

Failure to comply will result in death or serious injury.

Disconnect all power to the drive and wait at least the amount of time specified on the drive front cover safety label. After all indicators are off, measure the DC bus voltage to confirm safe level, and check for unsafe voltages before servicing. The internal capacitor remains charged after the power supply is turned off.

WARNING

Electrical Shock Hazard

Do not remove the front covers of the drive while the power is on.

Failure to comply could result in death or serious injury.

The diagrams in this section may include options and drives without covers or safety shields to show details. Be sure to reinstall covers or shields before operating any devices. Use the option according to the instructions described in this manual.

Do not allow unqualified personnel to use equipment.

Failure to comply could result in death or serious injury.

Maintenance, inspection, and replacement of parts must be performed only by authorized personnel familiar with installation, adjustment, and maintenance of this product.

Do not touch circuit boards while the power to the drive is on.

Failure to comply could result in death or serious injury.

5 Installation Procedure

WARNING

Do not use damaged wires, stress the wiring, or damage the wire insulation.

Failure to comply could result in death or serious injury.

Fire Hazard

Tighten all terminal screws to the specified tightening torque.

Loose electrical connections could result in death or serious injury by fire due to overheating of electrical connections.

NOTICE

Damage to Equipment

Observe proper electrostatic discharge (ESD) procedures when handling the option, drive, and circuit boards.

Failure to comply may result in ESD damage to circuitry.

Never shut the power off while the drive is running or outputting voltage.

Failure to comply may cause the application to operate incorrectly or damage the drive.

Do not operate damaged equipment.

Failure to comply may cause further damage to the equipment.

Do not connect or operate any equipment with visible damage or missing parts.

Do not use unshielded cable for control wiring.

Failure to comply may cause electrical interference resulting in poor system performance.

Use shielded twisted-pair wires and ground the shield to the ground terminal of the drive.

Properly connect all pins and connectors.

Failure to comply may prevent proper operation and possibly damage equipment.

Check wiring to ensure that all connections are correct after installing the option and connecting any other devices.

Failure to comply may result in damage to the option.

◆ Prior to Installing the Option

Prior to installing the option, wire the drive, make the necessary connections to the drive terminals, and verify that the drive functions normally. Refer to the Quick Start Guide packaged with the drive for information on wiring and connecting the drive.

Figure 2 shows an exploded view of the drive with the option and related components for reference.

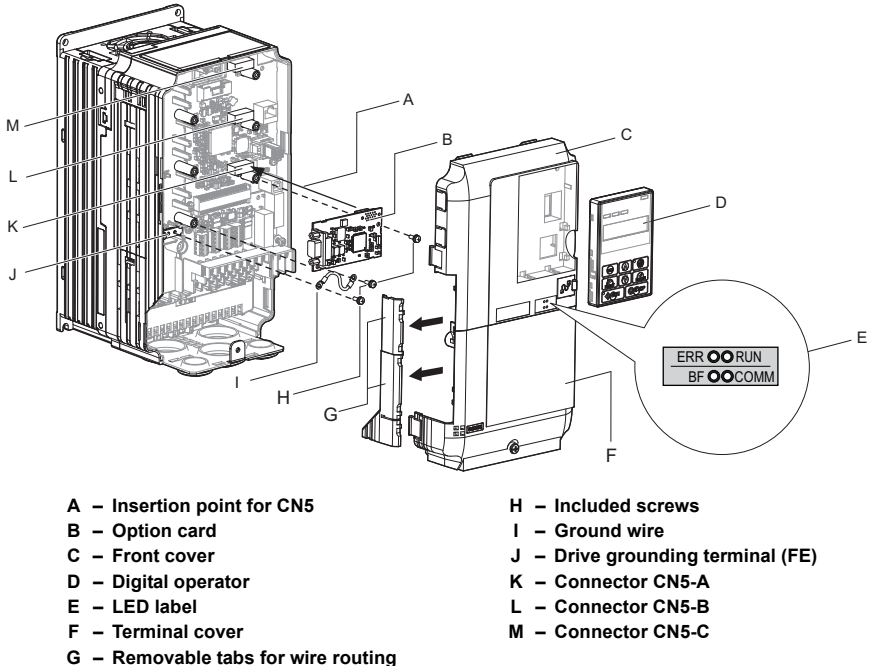

Figure 2 Drive Components with Option

5 Installation Procedure

◆ Installing the Option

Refer to the instructions below to install the option.

1. Shut off power to the drive, wait the appropriate amount of time for voltage to dissipate, then remove the digital operator (D), front cover (C), and terminal cover (F). Refer to the Quick Start Guide packaged with the drive for directions on removing the front covers. Cover removal varies depending on drive size.

DANGER! *Electrical Shock Hazard. Disconnect all power to the drive and wait at least the amount of time specified on the drive front cover safety label. After all indicators are off, measure the DC bus voltage to confirm safe level, and check for unsafe voltages before servicing to prevent electric shock. The internal capacitor remains charged even after the power supply is turned off.*

NOTICE: *Damage to Equipment. Observe proper electrostatic discharge procedures (ESD) when handling the option, drive, and circuit boards. Failure to comply may result in ESD damage to circuitry.*

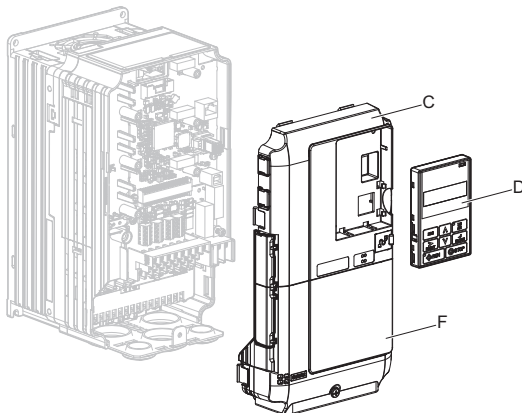

Figure 3 Remove the Front Cover, Terminal Cover, and Digital Operator

2. With the front covers and digital operator removed, apply the LED label (E) in the appropriate position on the drive top front cover (C).

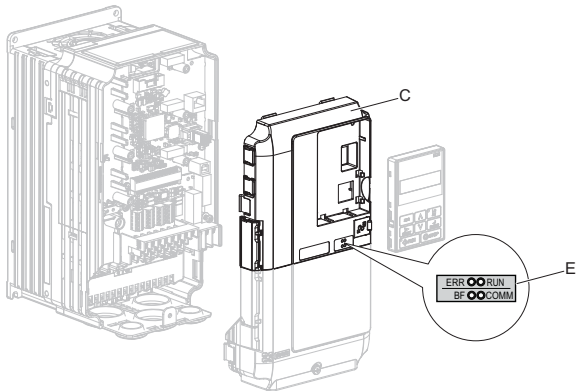

Figure 4 Apply the LED Label

3. Insert the option card (B) into the CN5-A connector (K) located on the drive and fasten it using one of the included screws (H).

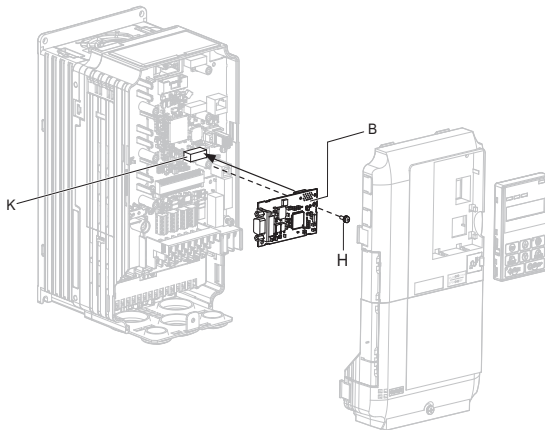

Figure 5 Insert the Option Card

5 Installation Procedure

4. Connect the ground wire (I) to the ground terminal (J) using one of the remaining provided screws (H). Connect the other end of the ground wire (I) to the remaining ground terminal and installation hole on the option using the last remaining provided screw (H).

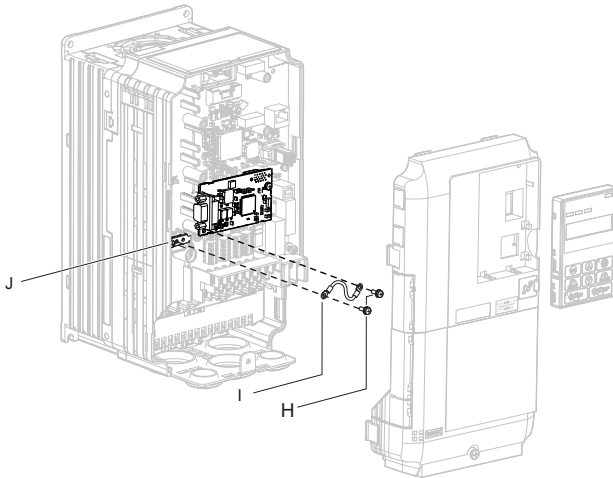

Figure 6 Connect the Ground Wire

Note: There are two screw holes on the drive for use as ground terminals. When connecting three options, two ground wires will need to share the same drive ground terminal.

5. Select the proper type of PROFIBUS-DP-dedicated cables and network cable. **Refer to Communication Cable Specifications on page 22** for details on cable selections and cable lengths. Refer to the PROFIBUS-DP website at www.profibus.com for more information on cables and connectors.

6. Connect the option to the network using PROFIBUS-DP-dedicated cables as shown in [Figure 8](#).

Connection Diagram

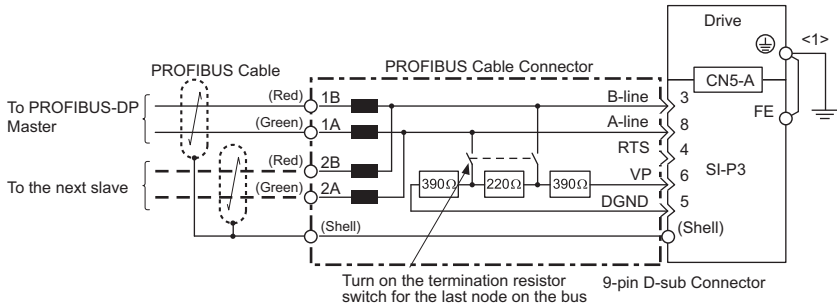

Figure 7 Option Connection Diagram

<1> The ground wire provided in the option shipping package must be connected during installation.

PROFIBUS-DP Termination

The option does not have a termination resistor. The termination resistance must be set on the final drive in the network using a switch on the 9-pin D-sub connector. Make sure that only the connector for the final drive in the network has a termination resistor; communication problems may arise if any other network drive has a termination resistor.

Use only the input side cable entry as shown in [Figure 8](#) when connecting both ends of the network. Most 9-pin D-sub connectors have a function for disconnecting the output side of the cable. Communication will not be possible between devices if the connector is reversed. Most connectors have arrows indicating the input and output sides.

5 Installation Procedure

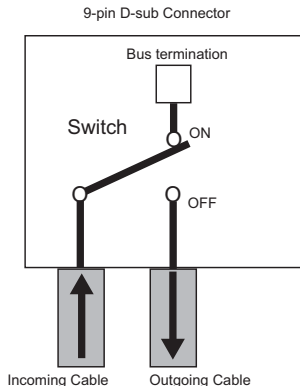
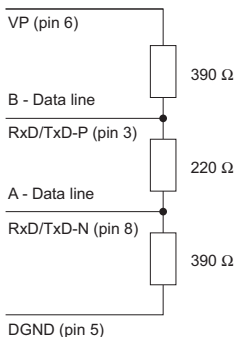

Figure 8 PROFIBUS Cable Connection with Termination Resistors

Bus termination ON = incoming and outgoing cables not connected.

Bus termination OFF = incoming and outgoing cables connected.

Termination resistors without inductors as shown in [Figure 9](#) can only be used for baud rates below 1.5 Mbps. Baud rates 1.5 Mbps and higher require termination with resistors and inductors as shown in [Figure 7](#).



**Figure 9 Cable Termination of the Option Cable to EN50170
(Pin Numbers for a 9-pin D-sub Connector)**

7. Route the option wiring.
Depending on the drive model, some drives may require routing the wiring through the side of the front cover to the outside. In these cases, use diagonal cutters to cut out the perforated openings in the left side of the drive front cover as shown in [Figure 10-A](#), and leave no sharp edges to damage wiring.

Route the wiring inside the enclosure as shown in [Figure 10-B](#) for drives that do not require routing through the front cover. Refer to the Peripheral Devices & Options section of the drive Technical Manual for more information.

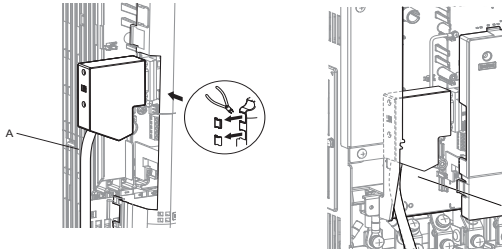

A – Route wiring through the openings on the left side of the front cover.

<1>

B – Use the open space inside the drive to route option wiring.

<1> The drive will not meet NEMA Type 1 requirements if wiring is exposed outside the enclosure.

Figure 10 Wire Routing Examples

8. After connecting the prepared cable for the 9-pin D-sub communication connector CN5, recheck the option wire routing performed in step 6.

5 Installation Procedure

9. Replace and secure the front covers of the drive (C, F) and replace the digital operator (D).

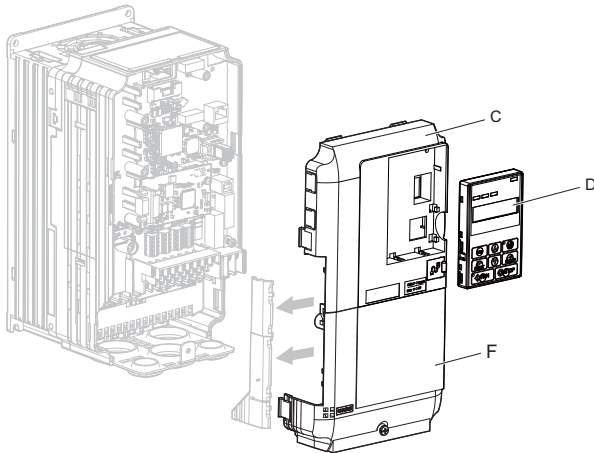

Figure 11 Replace the Front Covers and Digital Operator

Note: Take proper precautions when wiring the option so the front covers will easily fit back onto the drive. Make sure no cables are pinched between the front covers and the drive when replacing the covers.

10. Set drive parameters in [Table 8](#) for proper option performance. Be sure to set parameter F6-30 to a node address unique to the network.

◆ Communication Cable Specifications

To ensure proper performance, Yaskawa recommends using PROFIBUS-DP-dedicated cables that fulfill the specifications in [Table 6](#). Refer to the PROFIBUS-DP website at www.profibus.com for more information on cables.

■ Cable Requirements

Table 6 Communication Cable Requirements

Condition	Specifications
Impedance	135 to 165 Ω at a frequency of (3 to 20 MHz)
Capacity	30 pF/m maximum
Loop Resistance	110 Ω /km maximum
Core Cross-Section	0.34 mm ² minimum
Core Diameter	0.64 mm minimum

■ Cable Length

Communication speed determines maximum permissible cable length. [Table 7](#) shows the specifications for Type A bus cables.

Table 7 Communication Cable Length

Communication Speed (kbps)	Distance per Segment
9.6	1200 m (3937 ft.)
19.2	1200 m (3937 ft.)
45.45	1200 m (3937 ft.)
93.75	1200 m (3937 ft.)
187.5	1000 m (3280 ft.)
500	400 m (1312 ft.)
1500	200 m (656 ft.)
3000	100 m (328 ft.)
6000	100 m (328 ft.)
12000	100 m (328 ft.)

◆ GSD Files

To facilitate network implementation, obtain a GSD file from one of the following websites depending on your region:

U.S.: <http://www.yaskawa.com>

Europe: <http://www.yaskawa.eu.com>

Japan: <http://www.e-mechatronics.com>

Other areas: Contact your Yaskawa representative.

6 Related Parameters

The following parameters are used to set up the drive for operation with the option.

Confirm proper setting of all parameters in **Table 8** before starting network communications.

Table 8 Related Parameters

No. (Addr. Hex)	Name	Description	Values
b1-01 (180) </>	Frequency Reference Selection 1	Selects the frequency reference input source 0: Operator - Digital preset speed d1-01 to d1-17 1: Terminals - Analog input terminal A1 or A2 2: MEMOBUS/Modbus communications 3: Option 4: Pulse Input (Terminal RP)	Default: 1 Range: 0 to 4 (Set to 3 for SI-P3)
b1-02 (181) </>	Run Command Selection 1	Selects the run command input source 0: Digital Operator - RUN and STOP keys 1: Digital input terminals S□ 2: MEMOBUS/Modbus communications 3: Option	Default: 1 Range: 0 to 3 (Set to 3 for SI-P3)
F6-01 (3A2)	Communications Error Operation Selection	Determines drive response after a BUS error is detected during communications with the option 0: Ramp to Stop 1: Coast to Stop 2: Fast-Stop 3: Alarm Only <2>	Default: 1 Range: 0 to 3
F6-02 (3A3)	External Fault from Comm. Option Detection Selection	Sets the condition for external fault detection (EF0) 0: Always detected 1: Detected only during operation	Default: 0 Range: 0, 1
F6-03 (3A4)	External Fault from Comm. Option Operation Selection	Determines drive response for external fault input (EF0) detection during PROFIBUS communication 0: Ramp to Stop 1: Coast to Stop 2: Fast-Stop 3: Alarm Only <2>	Default: 1 Range: 0 to 3
F6-06 (3A7) <3>	Torque Reference/Torque Limit Selection from Comm. Option	0: Torque reference/torque limit via network communications are disabled. 1: Torque reference/torque limit via network communications are enabled. <4>	Default: 0 Range: 0, 1
F6-07 (3A8)	Multi-Step Speed Enable/Disable Selection when NefRef/ComRef is Selected	0: Multi-step speed reference disabled (F7 functionality) 1: Multi-step speed reference allowed (V7 functionality)	Default: 0 Range: 0, 1

No. (Addr. Hex)	Name	Description	Values
F6-08 (36A)	Reset Communication Parameters	Determines which F6-□□ and F7-□□ parameters are reset to default values when initializing the drive using A1-03. 0: Do not reset parameters 1: Reset parameters Note: Setting this parameter does not affect communication-related parameters. Setting this parameter only determines if communication-related parameters (F6-□□ and F7-□□) are also reset when initializing with A1-03.	Default: 0 Range: 0, 1
F6-30 (3CB) <5> <6>	PROFIBUS-DP Node Address	0 to 125	Default: 0 Min: 0 Max: 125
F6-31 (3CC)	PROFIBUS-DP Clear Mode Selection	Selects the action to take when a “Clear Mode” command is received 0: Resets to 0 1: Maintains the previous value	Default: 0 Range: 0, 1
F6-32 (3CD) <6>	PROFIBUS-DP Data Format Selection	0: PPO Type 1: Conventional	Default: 0 Range: 0, 1
F6-33 <6>	IND Data Size Selection	0: Word 1: Byte	Default: 0 Range: 0, 1

- <1> Set b1-02 to 3 to start and stop the drive through the PROFIBUS-DP network. Set b1-01 to 3 to control the frequency reference of the drive via the PROFIBUS-DP network.
- <2> Take proper safety measures when setting F6-03 to 3, such as installing an emergency stop switch, as the drive will continue operation when detecting an EF0 fault.
- <3> Enabled in CLV, AOLV/PM, and CLV/PM control modes (A1-02 = 3, 6, or 7). When enabled, d5-01 determines whether the value is read as the torque limit value (d5-01 = 0) or as the torque reference value (d5-01 = 1). In CLV/PM, this value is read as the torque limit.
- <4> Default setting specifies that the torque reference or torque limit is to be provided via network communications (F6-06 = 1). The motor may not rotate if no torque reference or torque limit is supplied from the PLC.
- <5> All node addresses must be unique. Node addresses 0, 1, and 2 are typically reserved for control, maintenance, and diagnostic equipment. The “Err” LED will illuminate when a value of 0 or a value greater than 125 is entered.
- <6> Cycle power for setting changes to take effect.

7 Option Data and I/O Maps

◆ Conventional Formats

The PROFIBUS-DP master configuration tool sets the I/O data length of the option from Extended Data 1 (32 bytes), Extended Data 2 (12 bytes), and Basic Data (6 bytes).

Conventional formats have two message types: High-speed I/O Data and MEMOBUS/Modbus message. Set parameter F6-32 to 1 to use conventional formats.

■ High-Speed I/O Data

High-speed I/O data is directly transferred between the drive and controller or PLC. When the drive is set for PROFIBUS-DP communications, the drive Run/Stop and Frequency Reference commands are transferred within 2 ms after being received by the option.

■ MEMOBUS/Modbus Message

MEMOBUS/Modbus message data is transferred between the drive and controller or PLC using MEMOBUS/Modbus messages. All drive parameters and data can be accessed through MEMOBUS/Modbus. The data in this message type is transferred to the drive after being received and edited by the option and more time is required to return the data to the master. The master must synchronize the timing of sending and receiving the data by a process called handshaking.

◆ Memory Maps

The following register maps show the I/O data bytes.

■ Basic and Extended Register Maps

Table 9 Number of Bytes in Basic and Extended Data Messages

	Basic Data (6 bytes)	Extended Data 1 (32 bytes)	Extended Data 2 (12 bytes)
High-speed I/O Data	Bytes 0 to 5	Bytes 0 to 15	Bytes 0 to 3
MEMOBUS/Modbus Data	–	Bytes 16 to 31	Bytes 4 to 11

Table 10 Basic Data Register Map Detail

Output (Master Device to Drive)		Input (Drive to Master Device)	
Byte	Description	Byte	Description
0	Operation Command High Byte	0	Drive Status High Byte
1	Operation Command Low Byte	1	Drive Status Low Byte
2	Frequency Reference High Byte	2	Motor Speed High Byte <3>

Output (Master Device to Drive)		Input (Drive to Master Device)	
Byte	Description	Byte	Description
3	Frequency Reference Low Byte	3	Motor Speed Low Byte <3>
4	Torque Reference/Torque Limit High Byte <1> <2>	4	Output Current High Byte <4>
5	Torque Reference/Torque Limit Low Byte <1> <2>	5	Output Current High Byte <4>

- <1> Enabled in CLV, AOLV/PM, and CLV/PM control modes (A1-02 = 3, 6, or 7).
- <2> Set when network communication is designated as the source of the torque limit and torque reference (F6-06 = 1). When enabled, d5-01 determines whether the value is read as the torque limit value (d5-01 = 0) or as the torque reference value (d5-01 = 1). In CLV/PM, this value is read as the torque limit.
- <3> Unit depends on the setting of o1-03 (Digital Operator Display Scaling). When the drive is operating in V/f Control or OLV/PM, the drive output frequency becomes the input data.
- <4> Data is displayed in units of 0.01 A for drives 7.5 kW and smaller, and in units of 0.1 A for drives 11 kW and larger. The number of decimal places in the parameter value depends on the drive model and the ND/HD selection in parameter C6-01. For details, refer to the 1.3 Model Number and Nameplate Check of the drive Technical Manual.

Table 11 Extended Data 1 Register Map

Output (Master Device to Drive)		Input (Drive to Master Device)	
Byte	Description	Byte	Description
0	Operation Command High Byte	0	Drive Status High Byte
1	Operation Command Low Byte	1	Drive Status Low Byte
2	Frequency Reference High Byte	2	Motor Speed High Byte <5>
3	Frequency Reference Low Byte	3	Motor Speed Low Byte <5>
4	Torque Reference High Byte <1> <2>	4	Torque Reference Monitor High Byte <6>
5	Torque Reference Low Byte <1> <2>	5	Torque Reference Monitor Low Byte <6>
6	Torque Compensation High Byte <1>	6	Speed Detection PG Pulse Count 1 High Byte
7	Torque Compensation Low Byte <1>	7	Speed Detection PG Pulse Count 1 Low Byte
8	Reserved	8	Frequency Reference High Byte
9		9	Frequency Reference Low Byte
10	Analog Output Channel 1 High Byte <3>	10	Output Frequency High Byte
11	Analog Output Channel 1 Low Byte <3>	11	Output Frequency Low Byte
12	Analog Output Channel 2 High Byte <3>	12	Output Current High Byte <7>
13	Analog Output Channel 2 Low Byte <3>	13	Output Current Low Byte <7>
14	Digital Output High Byte <4>	14	Analog Input Channel 1 High Byte
15	Digital Output Low Byte <4>	15	Analog Input Channel 1 Low Byte
16	MEMOBUS/Modbus Function Code	16	MEMOBUS/Modbus Function Code
17	MEMOBUS/Modbus Starting Register Address High Byte	17	MEMOBUS/Modbus Starting Register Address High Byte
18	MEMOBUS/Modbus Starting Register Address Low Byte	18	MEMOBUS/Modbus Starting Register Address Low Byte
19	MEMOBUS/Modbus Number of Data	19	MEMOBUS/Modbus Number of Data

7 Option Data and I/O Maps

Output (Master Device to Drive)		Input (Drive to Master Device)	
Byte	Description	Byte	Description
20	MEMOBUS/Modbus Data 1 High Byte	20	MEMOBUS/Modbus Data 1 High Byte
21	MEMOBUS/Modbus Data 1 Low Byte	21	MEMOBUS/Modbus Data 1 Low Byte
22	MEMOBUS/Modbus Data 2 High Byte	22	MEMOBUS/Modbus Data 2 High Byte
23	MEMOBUS/Modbus Data 2 Low Byte	23	MEMOBUS/Modbus Data 2 Low Byte
24	MEMOBUS/Modbus Data 3 High Byte	24	MEMOBUS/Modbus Data 3 High Byte
25	MEMOBUS/Modbus Data 3 Low Byte	25	MEMOBUS/Modbus Data 3 Low Byte
26	MEMOBUS/Modbus Data 4 High Byte	26	MEMOBUS/Modbus Data 4 High Byte
27	MEMOBUS/Modbus Data 4 Low Byte	27	MEMOBUS/Modbus Data 4 Low Byte
28	Reserved	28	Reserved
29		29	
30		30	
31	Handshaking Register	31	Handshaking Register

- <1> Enabled in CLV, AOLV/PM, and CLV/PM control modes (A1-02 = 3, 6, or 7).
- <2> Set when network communication is designated as the source of the torque limit and torque reference (F6-06 = 1). When enabled, d5-01 determines whether the value is read as the torque limit value (d5-01 = 0) or read as the torque reference value (d5-01 = 1). In CLV/PM, this value is read as the torque limit.
- <3> To select drive analog output channel for communications, set H4-01 (Multi-Function Analog Output Terminal FM) and H4-04 (Multi-Function Analog Output Terminal AM) to 000 (through-mode).
- <4> Drive digital output ON/OFF during communications, set H2-01 (Terminal M1, M2 and MC Function Selection (relay)), H2-02 (Terminal P1 Function Selection (open-collector)), and H2-03 (Terminal P2 Function Selection (open-collector)) to F (through-mode).
- <5> Unit depends on the setting of o1-03 (Digital Operator Display Scaling). Input data is 0 when the drive is set for V/f Control or OLV/PM.
- <6> Not possible when using V/f control, V/f with PG, or OLV/PM (A1-02 = 0, 1, or 5).
- <7> Data is displayed in units of 0.01 A for drives 7.5 kW and smaller, and in units of 0.1 A for drives 11 kW and larger. The number of decimal places in the parameter value depends on the drive model and the ND/HD selection in parameter C6-01. For details, refer to the 1.3 Model Number and Nameplate Check of the drive Technical Manual.

Table 12 Extended Data 2 Register Map

Output (Master Device to Drive)		Input (Drive to Master Device)	
Byte	Description	Byte	Description
0	Operation Command High Byte	0	Drive Status High Byte
1	Operation Command Low Byte	1	Drive Status Low Byte
2	Frequency Reference High Byte	2	Motor Speed High Byte </>
3	Frequency Reference Low Byte	3	Motor Speed Low Byte </>
4	MEMOBUS/Modbus Function Code	4	MEMOBUS/Modbus Function Code
5	MEMOBUS/Modbus Starting Register Address High Byte	5	MEMOBUS/Modbus Starting Register Address High Byte
6	MEMOBUS/Modbus Starting Register Address Low Byte	6	MEMOBUS/Modbus Starting Register Address Low Byte

Output (Master Device to Drive)		Input (Drive to Master Device)	
Byte	Description	Byte	Description
7	MEMOBUS/Modbus Data Length	7	MEMOBUS/Modbus Data Length
8	MEMOBUS/Modbus Data 1 High Byte	8	MEMOBUS/Modbus Data 1 High Byte
9	MEMOBUS/Modbus Data 1 Low Byte	9	MEMOBUS/Modbus Data 1 Low Byte
10	Reserved	10	Reserved
11	Handshaking Register	11	Handshaking Register

<1> Unit depends on the setting of o1-03 (Digital Operator Display Scaling). When the drive is operating in V/f Control or OLV/PM, the drive output frequency becomes the input data.

◆ Supported Parameter Process Data Object (PPO) Type Formats

Set drive parameter F6-32 to 0 to use PPO type formats. The PPO is defined for cyclic data transfer, allowing the master and the slave to exchange process data (PZD) and parameters. Refer to the PROFIBUS specification for more information on PPO types 1~5.

The option supports five possible PPO type formats:

- PPO type 1 (8 octets PKW + 4 octets PZD)
- PPO type 2 (8 octets PKW + 12 octets PZD)
- PPO type 3 (4 octets PZD)
- PPO type 4 (12 octets PZD)
- PPO type 5 (8 octets PKW + 20 octets PZD)

All PPO Types have the registers STW, ZSW, HSW, and HIW. These registers are not mapped directly to drive registers.

8 Troubleshooting

◆ Drive-Side Error Codes

Table 13 lists the various fault codes related to the option. Further details on various faults can be found in the drive Technical Manual.

■ Faults

Both bUS (Option Communication Error) and EF0 (External Fault Input from the option) can appear as either an alarm or as a fault. When a fault occurs, the digital operator ALM LED remains lit. When an alarm occurs, the digital operator ALM LED flashes.

Check the following items first when an error code occurs on the drive:

- Communication cable connections
- Make sure the option is properly installed to the drive
- Operation status of the controller program and controller CPU
- Did a momentary power loss interrupt communications?

Table 13 Fault Displays, Causes, and Possible Solutions

Digital Operator Display		Fault Name
<i>bUS</i>	bUS	Option Communication Error
		The connection was lost after establishing initial communication. Only detected when the run command frequency reference is assigned to the option (bl-01 = 3 or bl-02 = 3).
Cause		Possible Solution
Master controller (PLC) has stopped communicating.		Check for faulty wiring. Correct any wiring problems.
Communication cable is not connected properly.		
A data error occurred due to noise.		<ul style="list-style-type: none"> • Counteract noise in control circuit wiring, main circuit lines, and ground wiring. • If a magnetic contactor is the noise source, install a surge absorber to the contactor coil. • Use cables recommended by Yaskawa or another type of shielded line. Ground the shield on the controller side and on the option side.
Option is damaged.		If there are no wiring problems and the error continues to occur, replace the option.
Digital Operator Display		Fault Name
<i>EF0</i>	EF0	External Fault Input from the option
		The alarm function for an external device has been triggered.
Cause		Possible Solution
An external fault is being sent from the main controller (PLC).		<ul style="list-style-type: none"> • Remove the cause of the external fault. • Reset the external fault input from the PLC device.
Problem with the PLC program.		Check the program used by the PLC and make the appropriate corrections.

Digital Operator Display		Fault Name
oFA00	oFA00	Non-Compatible Option connected to drive port CN5-A
		Option is not properly connected.
Cause		Possible Solution
Non-compatible option connected to drive port CN5-A		Use only compatible options. Connect the SI-P3 to CN5-A. For other option connections, refer to the Installation Manual for those options.
Digital Operator Display		Fault Name
oFA01	oFA01	Option Fault (CN5-A)
		Option is not properly connected.
Cause		Possible Solution
Problem with the connector between the drive and option.		Turn the power off and check the connectors between the drive and option.
Digital Operator Display		Fault Name
oFA30 to oFA43	oFA30 to oFA43	Option Fault (CN5-A)
		Communication ID error.
Cause		Possible Solution
Option hardware fault.		Replace the option. Contact Yaskawa for assistance.
Digital Operator Display		Fault Name
oFb00	oFb00	Non-Compatible Option connected to drive port CN5-B
		Non-compatible option is connected.
Cause		Possible Solution
Non-compatible option connected to drive port CN5-B.		Use only compatible options. Connect the SI-P3 to CN5-A. For other option connections, refer to the Installation Manual for those options.
Digital Operator Display		Fault Name
oFb02	oFb02	Option Fault (CN5-B)
		Two of the same option are connected simultaneously.
Cause		Possible Solution
Options AI-A3 or DI-A3 connected to the CN5-B port while an option was connected to CN5-A.		Only one of these options, AI-A3, DI-A3 or SI-□□ option can be connected to the drive at the same time. The SI-N3 must be connected to CN5-A.
Digital Operator Display		Fault Name
oFc00	oFc00	Non-Compatible Option connected to drive port CN5-C
		Non-compatible option is connected.
Cause		Possible Solution
Non-compatible option connected to drive port CN5-C.		Use only compatible options. Connect the SI-P3 to CN5-A. For other option connections, refer to the Installation Manual for those options.

8 Troubleshooting

Digital Operator Display		Fault Name
	oFc02	Option Fault (CN5-C) Two of the same options are connected simultaneously.
Cause		Possible Solution
Options AI-A3 or D1-A3 connected to the CN5-C port while an option was connected to CN5-A.		Only one of these options, AI-A3, DI-A3 or SI-□□ option can be connected to the drive at the same time. The SI-N3 must be connected to CN5-A.

■ Minor Faults and Alarms

Digital Operator Display		Minor Fault Name	
	bb	Baseblock Data format and setting contents do not match.	
Cause		Possible Solution	Minor Fault (H2-□□ = 10)
The drive output is disabled. “bb” is displayed on the operator when the drive is set for control by PROFIBUS-DP, and a conventional data format is used, and the operation command bit F is set to 1, or a PPO type data format is used, and the control word (STW) bit 3 is set to 0.		Set either of the bits depending on the data format used.	No output
Digital Operator Display		Minor Fault Name	
	CALL	Serial Communication Transmission Error Communication has not yet been established.	
Cause		Possible Solution	Minor Fault (H2-□□ = 10)
Communication wiring or terminal resistor connection is faulty. There is a short circuit, or an option component is not connected properly.		Check for wiring errors and correct the wiring. Remove any ground shorts and reconnect loose wires.	Yes
Master-side programming error.		Check communications at start-up and correct programming errors.	
Damaged communication circuitry.		Perform a self-diagnostics check and replace the drive if the fault continues to occur.	

9 Specifications

Table 14 Option Specifications

Items	Specifications
Model	SI-P3
PROFIBUS-DP Data	<ul style="list-style-type: none"> • PROFIBUS-DP V0, V1 • PPO-TYPE: 1~5 (No. 3.072, Profile for Variable Speed Drives) • Extended data 1 High-speed I/O data (inputs: 16 bytes, outputs: 16 bytes) MEMOBUS/Modbus message (inputs: 16 bytes, outputs: 16 bytes) • Extended data 2 High-speed I/O data (inputs: 4 bytes, outputs: 4 bytes) MEMOBUS/Modbus message (inputs: 8 bytes, outputs: 8 bytes) • Basic data High-speed I/O data (inputs: 6 bytes, outputs: 6 bytes)
Connector	9-pin D-sub connector (#4/40 UNC thread)
Communications Speed	9.6 kbps to 12 Mbps
Ambient Temperature	-10 °C to +50 °C (14 °F to 122 °F)
Humidity	95% RH or lower with no condensation
Storage Temperature	-20 °C to +60 °C (-4 °F to 140 °F) allowed for short-term transport of the product
Area of Use	Indoor (free of corrosive gas, airborne particles, etc.)
Altitude	1000 m (3280 ft.) or lower

9 Specifications

◆ Revision History

Revision dates and manual numbers appear on the bottom of the back cover.

MANUAL NO. TOBP C730600 42A

Published in Japan April 2010 08-8 ①

└─ Date of publication
└─ Date of original publication
└─ Revision number

Date of Publication	Revision Number	Section	Revised Content
February 2014	⑥	Back cover	Revision: Address
April 2013	⑤	Back cover	Revision: Address
November 2010	④	Front cover, back cover	Revision: Format
		Entire document	Edited for procedural clarity and readability.
July 2010	③	Back cover	Revision: Address
July 2010	②	Entire document	Edited for procedural clarity and readability.
		Back cover	Revision: Address
April 2010	①	Back cover	Revision: Address
August 2008	—	—	First Edition

YASKAWA AC Drive 1000-Series Option PROFIBUS-DP Installation Manual

DRIVE CENTER (INVERTER PLANT)

2-13-1, Nishimiyaichi, Yukuhashi, Fukuoka, 824-8511, Japan
Phone: 81-930-25-3844 Fax: 81-930-25-4369
<http://www.yaskawa.co.jp>

YASKAWA ELECTRIC CORPORATION

New Pier Takeshiba South Tower, 1-16-1, Kaigan, Minatoku, Tokyo, 105-6891, Japan
Phone: 81-3-5402-4502 Fax: 81-3-5402-4580
<http://www.yaskawa.co.jp>

YASKAWA AMERICA, INC.

2121 Norman Drive South, Waukegan, IL 60085, U.S.A.
Phone: 1-800-YASKAWA (927-5292) or 1-847-887-7300 Fax: 1-847-887-7310
<http://www.yaskawa.com>

YASKAWA ELÉTRICO DO BRASIL LTDA.

Avenida Piraporinha 777, Diadema, São Paulo, 09950-000, Brasil
Phone: 55-11-3585-1100 Fax: 55-11-3585-1187
<http://www.yaskawa.com.br>

YASKAWA EUROPE GmbH

Hauptstrasse 185, 65760 Eschborn, Germany
Phone: 49-6196-569-300 Fax: 49-6196-569-398
<http://www.yaskawa.eu.com>

YASKAWA ELECTRIC KOREA CORPORATION

9F Kyobo Securities Bldg., 26-4, Yeouido-dong, Yeongdeungpo-gu, Seoul, 150-737, Korea
Phone: 82-2-784-7844 Fax: 82-2-784-8495
<http://www.yaskawa.co.kr>

YASKAWA ELECTRIC (SINGAPORE) PTE. LTD.

151 Lorong Chuan, #04-02A, New Tech Park, 556741, Singapore
Phone: 65-6282-3003 Fax: 65-6289-3003
<http://www.yaskawa.com.sg>

YASKAWA ELECTRIC (CHINA) CO., LTD.

12F, Carlton Bldg., No.21 HuangHe Road, HuangPu District, Shanghai 200003, China
Phone: 86-21-5385-2200 Fax: 86-21-5385-3299
<http://www.yaskawa.com.cn>

YASKAWA ELECTRIC (CHINA) CO., LTD. BEIJING OFFICE

Room 1011, Tower W3 Oriental Plaza, No. 1 East Chang An Ave.,
Dong Cheng District, Beijing, 100738, China
Phone: 86-10-8518-4086 Fax: 86-10-8518-4082

YASKAWA ELECTRIC TAIWAN CORPORATION

9F, 16, Nanking E. Rd., Sec. 3, Taipei, 104, Taiwan
Phone: 886-2-2502-5009 Fax: 886-2-2505-1280

YASKAWA INDIA PRIVATE LIMITED

#17A Electronics City, Hosur Road Bangalore 560 100 (Karnataka), India
Phone: 91-80-4244-1900 Fax: 91-80-4244-1901
<http://www.yaskawaindia.in>



YASKAWA ELECTRIC CORPORATION

In the event that the end user of this product is to be the military and said product is to be employed in any weapons systems or the manufacture thereof, the export will fall under the relevant regulations as stipulated in the Foreign Exchange and Foreign Trade Regulations. Therefore, be sure to follow all procedures and submit all relevant documentation according to any and all rules, regulations and laws that may apply. Specifications are subject to change without notice for ongoing product modifications and improvements.

© 2008-2014 YASKAWA ELECTRIC CORPORATION. All rights reserved.

MANUAL NO. TOBP C730600 42C

Published in Japan February 2014 08-8 -0
13-7-11