



YASKAWA

YASKAWA AC Drive-V1000 Option

DeviceNet Technical Manual

Type SI-N3/V

To properly use the product, read this manual thoroughly and retain for easy reference, inspection, and maintenance. Ensure the end user receives this manual.

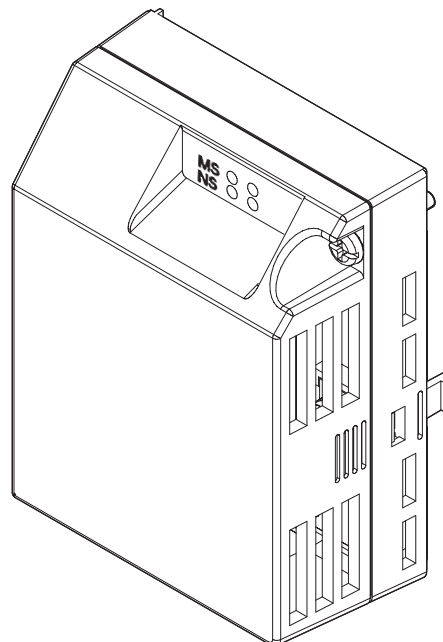

Copyright © 2008 YASKAWA ELECTRIC CORPORATION

All rights reserved. No part of this publication may be reproduced, stored in a retrieval system, or transmitted, in any form or by any means, mechanical, electronic, photocopying, recording, or otherwise, without the prior written permission of Yaskawa. No patent liability is assumed with respect to the use of the information contained herein. Moreover, because Yaskawa is constantly striving to improve its high-quality products, the information contained in this manual is subject to change without notice. Every precaution has been taken in the preparation of this manual. Yaskawa assumes no responsibility for errors or omissions. Neither is any liability assumed for damages resulting from the use of the information contained in this publication.



Table of Contents

1	PREFACE AND SAFETY	4
2	PRODUCT OVERVIEW	8
3	RECEIVING	9
4	DEVICENET OPTION COMPONENTS	10
5	INSTALLATION PROCEDURE	14
6	DEVICENET OPTION DRIVE PARAMETERS	20
7	CONFIGURING DEVICENET MESSAGING	23
8	DEVICENET OPTION DETAILS	25
9	OUTPUT ASSEMBLIES (DRIVE CONSUMES)	26
10	INPUT ASSEMBLIES (DRIVE PRODUCES)	47
11	GENERAL CLASS OBJECTS	71
12	VENDOR-SPECIFIC (YASKAWA) CLASS OBJECTS	84
13	TROUBLESHOOTING	86
14	SPECIFICATIONS	92

1 Preface and Safety

Yaskawa manufactures products used as components in a wide variety of industrial systems and equipment. The selection and application of Yaskawa products remain the responsibility of the equipment manufacturer or end user. Yaskawa accepts no responsibility for the way its products are incorporated into the final system design. Under no circumstances should any Yaskawa product be incorporated into any product or design as the exclusive or sole safety control. Without exception, all controls should be designed to detect faults dynamically and fail safely under all circumstances. All systems or equipment designed to incorporate a product manufactured by Yaskawa must be supplied to the end user with appropriate warnings and instructions as to the safe use and operation of that part. Any warnings provided by Yaskawa must be promptly provided to the end user. Yaskawa offers an express warranty only as to the quality of its products in conforming to standards and specifications published in the Yaskawa manual. **NO OTHER WARRANTY, EXPRESSED OR IMPLIED, IS OFFERED.** Yaskawa assumes no liability for any personal injury, property damage, losses, or claims arising from misapplication of its products.

◆ Applicable Documentation

The following manuals are available for the DeviceNet Option:

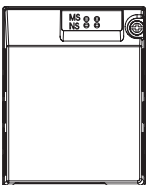
Option Unit	
	Yaskawa AC Drive -V1000 Option DeviceNet Installation Manual Manual No: TOBPC73060028
	Read this manual first. The installation manual is packaged with the DeviceNet Option and contains a basic overview of wiring, settings, functions, and fault diagnoses.
	Yaskawa AC Drive -V1000 Option DeviceNet Technical Manual Manual No: SIEPC73060028
	The technical manual contains detailed information. To obtain the technical manual access these sites: U.S.: http://www.yaskawa.com Europe: http://www.yaskawa.eu.com Japan: http://www.e-mechatronics.com Other areas: contact a Yaskawa representative.

Yaskawa Drive		
	Yaskawa AC Drive-V1000 Quick Start Guide	To obtain instruction manuals for Yaskawa products access these sites: U.S.: http://www.yaskawa.com Europe: http://www.yaskawa.eu.com Japan: http://www.e-mechatronics.com Other areas: contact a Yaskawa representative.
	Yaskawa AC Drive-V1000 Technical Manual	

◆ Terms

Note: Indicates a supplement or precaution that does not cause drive damage.

- Drive:** Yaskawa AC Drive -V1000 Series
- DeviceNet SI-N3/V Option:** Yaskawa AC Drive -V1000 Option DeviceNet
- ≥ 1011:** A drive feature or function that is only available in drive software version 1011 or later.

◆ Registered Trademarks

- DeviceNet is a trademark of the ODVA.
- All trademarks are the property of their respective owners.

◆ Supplemental Safety Information

Read and understand this manual before installing, operating, or servicing this option unit. The option unit must be installed according to this manual and local codes.

The following conventions are used to indicate safety messages in this manual. Failure to heed these messages could result in serious or possibly even fatal injury or damage to the products or to related equipment and systems.

DANGER

Indicates a hazardous situation, which, if not avoided, will result in death or serious injury.

WARNING

Indicates a hazardous situation, which, if not avoided, could result in death or serious injury.

CAUTION

Indicates a hazardous situation, which, if not avoided, could result in minor or moderate injury.

NOTICE

Indicates an equipment damage message.

■ General Safety

General Precautions

- The diagrams in this section may include option units and drives without covers or safety shields to illustrate details. Be sure to reinstall covers or shields before operating any devices. The option should be used according to the instructions described in this manual.
- Any illustrations, photographs, or examples used in this manual are provided as examples only and may not apply to all products to which this manual is applicable.
- The products and specifications described in this manual or the content and presentation of the manual may be changed without notice to improve the product and/or the manual.
- When ordering a new copy of the manual due to damage or loss, contact your Yaskawa representative or the nearest Yaskawa sales office and provide the manual number shown on the front cover.

DANGER

Heed the safety messages in this manual.

Failure to comply will result in death or serious injury.

The operating company is responsible for any injuries or equipment damage resulting from failure to heed the warnings in this manual.

NOTICE

Do not expose the drive to halogen group disinfectants.

Failure to comply may cause damage to the electrical components in the option unit.

Do not pack the drive in wooden materials that have been fumigated or sterilized.

Do not sterilize the entire package after the product is packed.

Do not modify the drive circuitry.

Failure to comply could result in damage to the drive and will void warranty.

YASKAWA is not responsible for any modification of the product made by the user. This product must not be modified.

■ Option Unit Warning Labels

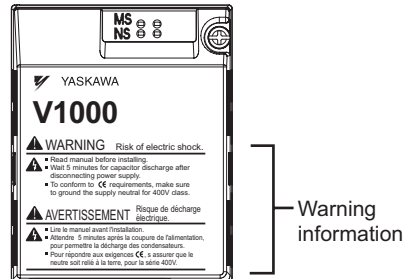

Warning information is displayed on the option unit as shown in the figure below. Follow all warnings and safety instructions when using the product.

When using the drive in an area that may require displaying warning information in Japanese or Chinese, a warning label is provided with the DeviceNet Option. This sticker can be placed over the English and French warnings on the front of the DeviceNet Option.





■ Warning Contents

WARNING Risk of electric shock.

-  Read manual before installing.
-  Wait 5 minutes for capacitor discharge after disconnecting power supply.
- To conform to **CE** requirements, make sure to ground the supply neutral for 400V class.

AVERTISSEMENT Risque de décharge électrique.

-  Lire le manuel avant l'installation.
-  Attendre 5 minutes après la coupure de l'alimentation, pour permettre la décharge des condensateurs.
- Pour répondre aux exigences **CE**, s'assurer que le neutre soit relié à la terre, pour la série 400V.

2 Product Overview

◆ About This Product

The DeviceNet option provides a communications connection between the drive and an ODVA DeviceNet network. The SI-N3/V DeviceNet Option connects the drive to a DeviceNet network and facilitates the exchange of data.

This manual explains the handling, installation and specifications of this product.

DeviceNet is a communications link to connect industrial devices (such as limit switches, photoelectric switches, valve manifolds, motor starters, smart motor controllers, operator interfaces, and variable frequency drives) as well as control devices (such as programmable controllers and computers) to a network. DeviceNet is a simple, networking solution that reduces the cost and time to wire and install factory automation devices, while providing interchangeability of "like" components from multiple vendors.

By installing the DeviceNet Option to a drive, it is possible to do the following from a DeviceNet master device:

- Operate the drive
- Monitor the operation status of the drive
- Change parameter settings.



Figure 1 DeviceNet Approved

◆ Applicable Models

The DeviceNet Option can be used with the drive models in [Table 1](#).

Table 1 Applicable Models

Drive	Software Version <1>
CIMR-V□□A□□□□□A□	≥ 1011

<1> See "PRG" on the drive nameplate for the software version number.

3 Receiving

Please perform the following tasks after receiving the DeviceNet Option:

- Inspect the DeviceNet Option for damage.
If the DeviceNet Option appears damaged upon receipt, contact the shipper immediately.
- Verify receipt of the correct model by checking the information on the nameplate (see [Figure 2](#)).
- If you have received the wrong model or the DeviceNet Option does not function properly, contact your supplier.

◆ Contents and Packaging

Table 2 Contents of Package

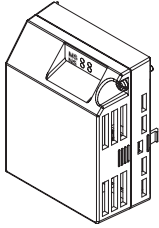
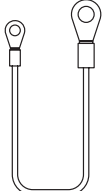
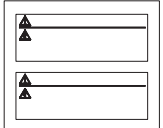
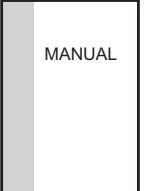
Description:	Option Unit	Ground Cables	Warning Labels	Installation Manual
—				
Quantity:	1	4	1	1

◆ Tool Requirements

A Phillips screwdriver (M3, M3.5 to M6 <I>) metric or (#1, #2 <I>) U.S. standard size is required to install the DeviceNet Option.
<I> Screw sizes vary by drive capacity. Select a screwdriver that matches the drive capacity.

Note: Tools required to prepare DeviceNet cables for wiring are not listed in this manual.

4 DeviceNet Option Components

◆ DeviceNet Option

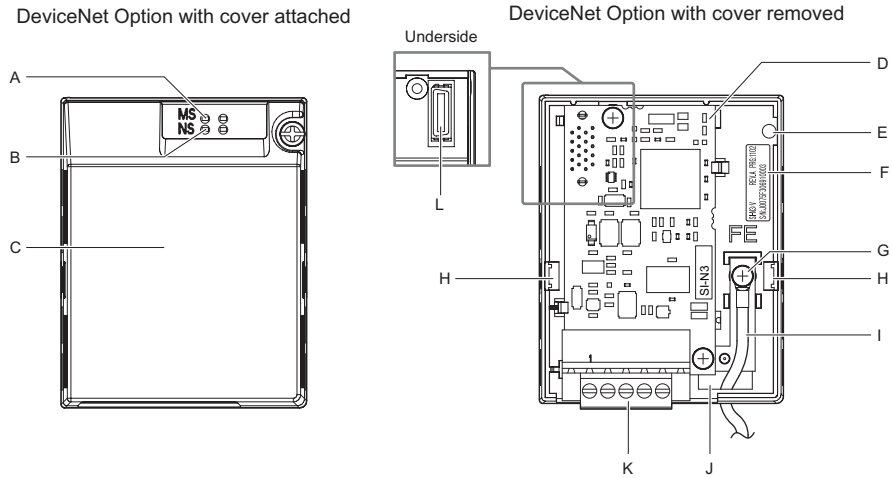

- A – LED (MS)**
- B – LED (NS)**
- C – Option cover**
- D – DeviceNet PCB**
- E – Attachment screw hole for option cover**
- F – Nameplate**
- G – Function Earth cable connection (FE)**
- H – Mounting tabs**
- I – Ground cable <1>**
- J – Pass-through hole for cable**
- K – Terminals**
- L – Option connector**

<1> Ground cables are packaged loose inside the DeviceNet Option shipping package and must be connected during installation.

Figure 2 Option Unit

Note: For details on the LEDs, [Refer to DeviceNet Option LED Display on page 12.](#)

◆ Dimensions

The installed DeviceNet Option adds 27 mm (1.06 in.) to the total depth of the drive.

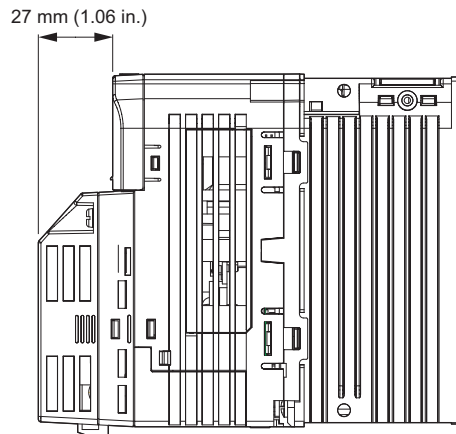

Figure 3 Dimensions

◆ Terminal Block

The communication connector is a pluggable terminal block. This pluggable terminal block is the connection point of the DeviceNet network communication cable to the Option.

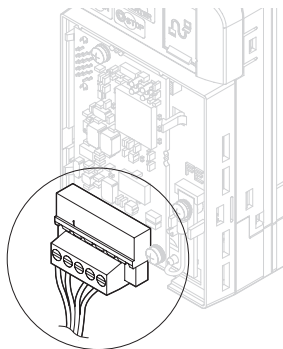
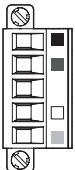

Figure 4 Pluggable terminal block

Table 3 Terminal Descriptions

Terminal	Pin	Color	Signal	Description
	1	Black	V-	Network common
	2	Blue	CAN_L	CAN data Low
	3	—	Shield	Cable shield
	4	White	CAN_H	CAN data High
	5	Red	V+	Communications DC+24V

4 DeviceNet Option Components

◆ DeviceNet Option LED Display

The DeviceNet Option has two bi-color, red/green LEDs, one for Module Status (MS) and one for Network Status (NS).

The operational states of the DeviceNet Option LEDs after the DeviceNet power-up diagnostic LED sequence is completed are described in [Table 5](#). Wait at least 2 seconds for the power-up diagnostic process to complete before verifying the states of the LEDs.

Table 4 DeviceNet Operation LED States

Name	Indication		Operating Status	Remarks
	Color	Status		
MS	–	OFF	Power supply OFF	Power is not being supplied to the drive.
	Green	ON	SI-N3/V Option operating	The SI-N3/V Option card is operating normally.
	Green	Flashing	SI-N3/V Option initializing	There is an incorrect baud rate setting or there is a MAC ID.
	Red	ON	Fatal error occurred	A fatal (irrecoverable) error occurred in the SI-N3/V Option.
	Red	Flashing	Non-fatal error occurred	A non-fatal (recoverable) error occurred.
	Green/Red	Flashing	Device self-test	Device in self-test mode.
NS	–	OFF	Offline or Power supply OFF	–
	Green	ON	Online communications established	Device is on-line and has connections in the established state.
	Green	Flashing	Online communications not established	Device is on-line but has no connections in the established state. Dup Mac-ID test has been passed, is on-line but has no open connections to other nodes.
	Red	ON	Communications error	An error occurred that disables DeviceNet communications. MAC ID duplication Bus Off detected
	Red	Flashing	Communications time-out	A communications time-out occurred with the master.
	Green/Red	Flashing	Communication faulted	Specific communication faulted device. The device has detected a network access error and is in the communications faulted state. The device has then received and accepted an Identify communication fault request-long protocol message.

■ Power-Up Diagnostics

An LED test is performed each time the drive is powered up. The initial boot sequence may take several seconds. After the LEDs have completed the DeviceNet diagnostic LED sequence, the DeviceNet Option is successfully initialized. The LEDs then assume operational conditions as shown in [Table 4](#).

Table 5 Power-Up Diagnostic LED Sequence

Sequence	Module Status (MS)	Network Status (NS)	Time (ms)
1	GREEN	OFF	250
2	RED	OFF	250
3	GREEN	GREEN	250
4	GREEN	RED	250
5	GREEN	OFF	-

◆ Set the DeviceNet Option MAC ID

■ Parameter F6-50, MAC ID Setting

Range: 0~64

The MAC ID is set by drive parameter F6-50. A MAC ID setting in the range of 0~63 is considered a valid MAC ID. A value other than 0~63 indicates the MAC ID is settable over the network.

The DeviceNet Option SI-N3/V reads the MAC ID value from parameter F6-50 upon power-up and upon a network reset.

◆ Set the DeviceNet Option Baud Rate

The DeviceNet Option will support standard baud rates of 125 kbps, 250 kbps, and 500 kbps.

Powering up the drive causes the DeviceNet Option to read parameter F6-51 and automatically configure the DeviceNet Option baud rate without the use of hardware switches.

Note: The DeviceNet Option also supports a network settable baud rate. Execution of a "Reset" service (Identity Object) will cause F6-51 to be set to a value of "0", 125 kBaud. The node will then attempt to connect to the network at 125 kBaud.

Table 6 Parameter F6-51 Baud Rate Setting

Description	Value
125 kbps	0
250 kbps	1
500 kbps	2
Programmable From Network	3
Auto Detect	4

■ Auto Baud Rate Sensing (F6-51 = 4)

Setting parameter F6-51 = 4, "Auto Detect" causes the DeviceNet Option to determine the data rate of the DeviceNet Network and configure itself appropriately.

Note: The auto baud capability will only be valid when there is more than one node physically on the DeviceNet network segment. The drive digital operator will display "bUS" and the DeviceNet option LEDs will be (NS-OFF and MS=Solid Green) as long as auto baud rate sensing fails to detect the baud rate.

5 Installation Procedure

◆ Section Safety

DANGER

Electrical Shock Hazard

Do not connect or disconnect wiring while the power is on.

Failure to comply will result in death or serious injury.

Disconnect all power to the drive, wait at least five minutes after all indicators are off, measure the DC bus voltage to confirm safe level, and check for unsafe voltages before servicing to prevent electric shock. The internal capacitor remains charged even after the power supply is turned off. The charge indicator LED will extinguish when the DC bus voltage is below 50 Vdc.

WARNING

Electrical Shock Hazard

Do not remove option cover while the power is on.

Failure to comply could result in death or serious injury.

The diagrams in this section may include option units and drives without covers or safety shields to show details. Be sure to reinstall covers or shields before operating any devices. The option should be used according to the instructions described in this manual.

Do not allow unqualified personnel to use equipment.

Failure to comply could result in death or serious injury.

Maintenance, inspection, and replacement of parts must be performed only by authorized personnel familiar with installation, adjustment, and maintenance of this product.

Do not remove option cover while the power to the drive is on.

Failure to comply could result in death or serious injury.

Do not use damaged wires, place excessive stress on wiring, or damage the wire insulation.

Failure to comply could result in death or serious injury.

Fire Hazard

Tighten all terminal screws to the specified tightening torque.

Loose electrical connections could result in death or serious injury by fire due to overheating of electrical connections.

NOTICE

Damage to Equipment

Observe proper electrostatic discharge (ESD) procedures when handling the option unit, drive, and circuit boards.

Failure to comply may result in ESD damage to circuitry.

Never shut the power off while the drive is outputting voltage.

Failure to comply may cause the application to operate incorrectly or damage the drive.

NOTICE

Do not operate damaged equipment.

Failure to comply may cause further damage to the equipment.

Do not connect or operate any equipment with visible damage or missing parts.

Do not use unshielded cable for control wiring.

Failure to comply may cause electrical interference resulting in poor system performance.

Use shielded twisted-pair wires and ground the shield to the ground terminal of the drive.

Properly connect all pins and connectors.

Failure to comply may prevent proper operation and possibly damage equipment.

Check wiring to ensure that all connections are correct after installing the option unit and connecting any other devices.

Failure to comply may result in damage to the option unit.

◆ **Wiring Diagram**

Figure 5 Wiring Diagram

<1> The FE terminal on the DeviceNet Option is supplied with a ground cable that should be connected to the ground terminal on the drive.

◆ **Prior to Installing the Option Unit**

Prior to installing the DeviceNet Option, wire the drive and make necessary connections to the drive terminals. Refer to the Quick Start Guide for information on wiring and connecting the drive. Verify that the drive functions normally prior to installing the Option.

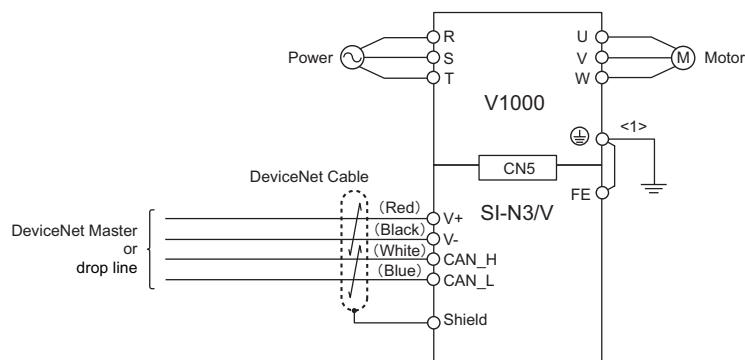
5 Installation Procedure

◆ Installing the Option Unit

Remove the front cover of the drive before installing the DeviceNet Option. Follow the directions below for proper installation.

1. Switch off the power supply to the drive.

DANGER! Electrical Shock Hazard - Do not connect or disconnect wiring while the power is on. Failure to comply will result in death or serious injury. Before installing the DeviceNet Option, disconnect all power to the drive. The internal capacitor remains charged even after the power supply is turned off. The charge indicator LED will extinguish when the DC bus voltage is below 50 Vdc. To prevent electric shock, wait at least five minutes after all indicators are off and measure the DC bus voltage level to confirm safe level.

2. Remove the front cover. The original drive front cover may be discarded because it will be replaced by the DeviceNet Option cover in step 8.

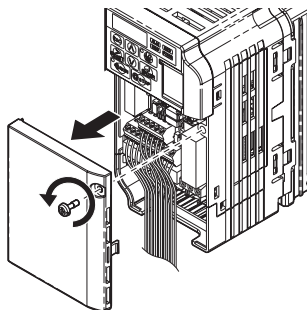

Figure 6 Remove Front Cover

3. Remove the bottom cover and connect the DeviceNet Option ground cable to the ground terminal.

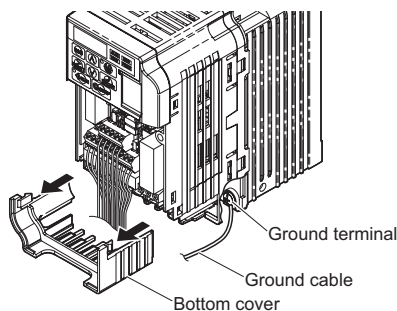
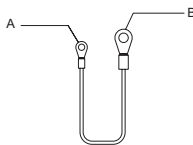

Figure 7 Connect Ground Cable

Note: The four different ground cables packaged with the DeviceNet Option connect the unit to different models. Select the proper ground cable from the DeviceNet Option kit depending on drive size.



A – Option unit connection: screw size = M3

B – Drive-side connection: screw size = M3.5 to M6

Figure 8 Ground Cable

Note: Cover removal for certain larger models with a Terminal Cover:

- Single-Phase 200 V Class: CIMR-V□BA0006 to BA0018
- Three-Phase 200 V Class: CIMR-V□2A0008 to 2A0069
- Three-Phase 400 V Class: All models

Remove the terminal cover before removing the bottom cover to install the DeviceNet Option. Replace the terminal cover after wiring the DeviceNet Option.

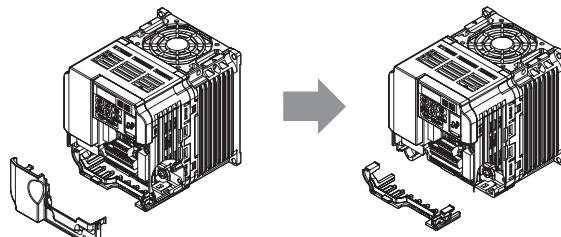

Figure 9 Models with Terminal Cover

4. Reattach the bottom cover.
5. Connect the DeviceNet Option to the drive. Properly secure the tabs on the left and right sides of the DeviceNet Option to the drive case.

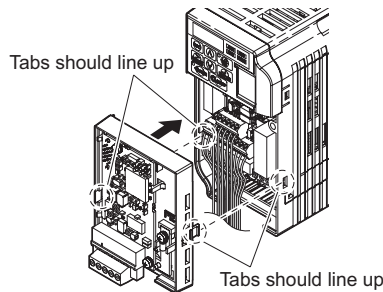

Figure 10 Attach DeviceNet Option

6. Connect the ground cable from the drive ground terminal to the DeviceNet Option ground. When wiring the DeviceNet Option, pass the ground cable through the inside of the drive bottom cover, then pass the ground cable into the through-hole at the front of the DeviceNet Option.

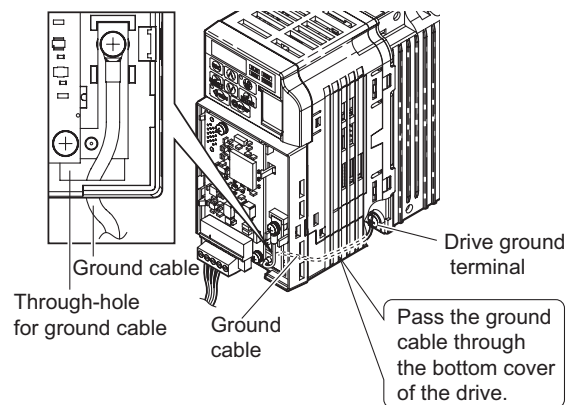

Figure 11 Ground Cable Connection

7. Connect the communications cable to the terminal block. Refer to procedure on page 18.
8. Attach the DeviceNet Option cover to the front of the DeviceNet Option.

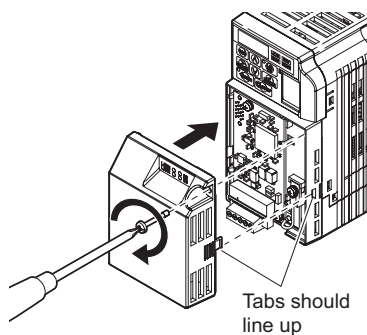

Figure 12 Attach Cover

Note: When using the drive in an area that may require displaying warning information in Japanese or Chinese, a label is provided with

5 Installation Procedure

the DeviceNet Option. This label can be placed over the English and French warnings on the front of the DeviceNet Option.

◆ Communication Cable Wiring

■ Procedure

Follow the instructions below to connect the communications cable to the terminal block.

WARNING! Tighten all terminal screws according to the specified tightening torque. Tightening screws too tight could damage the terminal block, and leaving screws too loose can cause a short-circuit or drive malfunction.

1. Connect the communications cable to the terminal block as shown in the diagram below.

Note: Communication lines should be separated from main circuit wiring and other electrical lines. (Tightening torque: 0.5 to 0.6 (N·m) or 4.4 to 5.3 (inch-lbs)) for Network Cable Wiring.

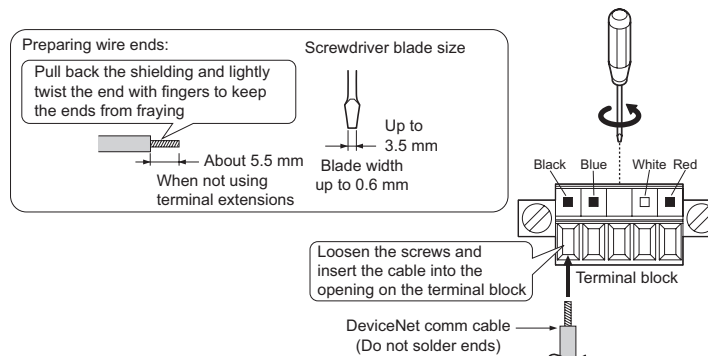

Figure 13 Communication Cable Wiring

2. Ensure all wiring connections are tightened and wire insulation is not pinched in the terminal block. Remove any stray wire strands that touch other terminals.
3. After the terminal block is fully attached to the option unit, tighten the screws on the left and right sides of the terminal block. (Tightening torque: 0.5 to 0.6 (N·m) or 4.4 to 5.3 (inch-lbs)).

Note: Be sure to put the option cover back on after all wiring is completed.

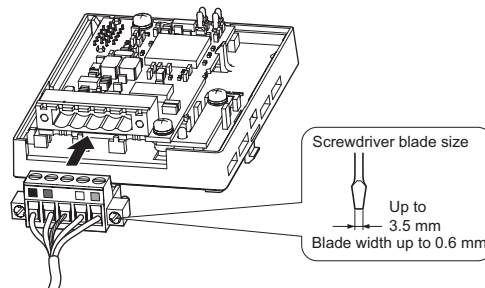

Figure 14 Terminal Block Installation

◆ Termination Resistor Connection

A network termination resistor (121Ω , $\pm 1\%$, $1/4$ W) must be connected only to nodes of the two ends of trunkline. Refer to ODVA specification for more details on DeviceNet termination.

◆ Communication Cable Specifications

Refer to the ODVA website for more information on network cabling (<http://www.odva.org/>).

◆ Cable Length

■ Trunk Line

The maximum allowed trunk line length depends on the type of cable used and the network baud rate. The total cable length includes the length of the trunk and the sum of all the drop lines.

Table 7 Trunk Line Cable Length

Baud Rate (kbps)	Thick Cable (m)	Thin Cable (m)
125	500	100
250	250	100
500	100	100

To calculate the maximum total length for trunk lines of mixed thick and thin cables, use the following formulas:

- 125 kbps: $L_{\text{thick}} + (5 \times L_{\text{thin}}) \leq 500 \text{ m}$
- 250 kbps: $L_{\text{thick}} + (2.5 \times L_{\text{thin}}) \leq 250 \text{ m}$
- 500 kbps: $L_{\text{thick}} + L_{\text{thin}} \leq 100 \text{ m}$

■ Drop Line

The drop line is measured from the tap on the trunk line to the transceiver of the DeviceNet node. Note that the total cable length includes the length of the trunk and the sum of all the drop lines.

Table 8 Drop Line Cable Length

Baud Rate (kbps)	Maximum at Each Drop (m)	Maximum Total (m)
125	6	156
250		78
500		39

◆ EDS Files

For easy network implementation of drives equipped with a SI-N3/V, an EDS file can be obtained from:

U.S.: <http://www.yaskawa.com>

Other areas: Contact a Yaskawa representative.

6 DeviceNet Option Drive Parameters

Confirm proper setting of the all parameters in [Table 9](#) before starting network communications.

Table 9 Parameter Settings

No. (Addr. Hex)	Name	Description	Values
b1-01 (180) <>	Frequency Reference Selection	Selects the frequency reference input source 0: Operator - Digital preset speed d1-01 to d1-17 1: Terminals - Analog input terminal A1 or A2 2: MEMOBUS/Modbus communications 3: Option PCB 4: Pulse Input (Terminal RP)	Default: 1 Range: 0~4 (Set to 3 for DeviceNet only)
b1-02 (181) <>	Run Command Selection	Selects the run command input source 0: Digital Operator - RUN and STOP keys 1: Digital input terminals S1 to S7 2: MEMOBUS/Modbus communications 3: Option PCB	Default: 1 Range: 0~3 (Set to 3 for DeviceNet only)
F6-01 (3A2)	Operation Selection after Communications Error	Determines drive response when a bUS error is detected during communications with the DeviceNet Option 0: Ramp to Stop 1: Coast to Stop 2: Fast-Stop 3: Alarm Only <>	Default: 1 Range: 0~3
F6-02 (3A3)	External Fault Detection Conditions (EF0)	Sets the condition for external fault detection (EF0) 0: Always detected 1: Detected only during operation	Default: 0 Range: 0~1
F6-03 (3A4)	Stopping Method for External Fault from Communication Option	Determines drive response for external fault input (EF0) detection during DeviceNet communication 0: Ramp to Stop 1: Coast to Stop 2: Fast-Stop 3: Alarm Only <>	Default: 1 Range: 0~3
F6-07 (3A8) <>	NetRef/ComRef Selection Function	0: multi-step speed reference disabled (F7 mode) 1: multi-step speed reference allowed (V7 mode)	Default: 1
F6-08 (36A) <>	Reset Communication Related Parameters	Determines which communications-related parameters are set back to their original default values when the drive is initialized. 0: Do not reset F6-□□ and F7-□□ parameters when the drive is initialized using parameter A1-03. 1: Reset F6-□□ and F7-□□ parameters when the drive is initialized using parameter A1-03. Note: Setting this parameter does not affect communication-related parameters.	Default: 0
F6-50 (3C1) <>	MAC ID	Selects the drive MAC address <> Note: Used in the DeviceNet Object	Default: 0 Range: 0~64 <>
F6-51 (3C2)	Baud Rate	DeviceNet communication speed 0: 125 kbps 1: 250 kbps 2: 500 kbps 3: Programable from Network <> 4: Detect automatically <> Note: Used in the DeviceNet Object	Default: 0 Range: 0~4 <>
F6-52 (3C3) <>	PCA setting	I/O Polled Consuming Assembly data instance Note: Used in the Connection Object	Default: 21 Range: 0~255

No. (Addr. Hex)	Name	Description	Values
F6-53 (3C4) <7>	PPA setting	I/O Polled Producing Assembly data instance Note: Used in the Connection Object	Default: 71 Range: 0~255
F6-54 (3C5)	Idle Mode Fault Detection Selection	When detection is enabled and idle messages are detected, the option will set Run and Frequency to 0. 0: Detection enabled 1: No detection	Default: 0 Range: 0~1
F6-55 (3C6) <6>	Baud rate from Network	(Read only) DeviceNet actual communication speed 0: 125 kbps 1: 250 kbps 2: 500 kbps Note: Used in the DeviceNet Object	Range: 0~2
F6-56 (3D7)	Speed Scaling	Sets the scaling factor for the Speed Monitor in the DeviceNet Object Class 2A hex Note: Used in the AC/DC Drive Object	Default: 0 Range: -15~15
F6-57 (3D8)	Current Scaling	Sets the scaling factor for the Output Current Monitor in the DeviceNet Object Class 2A hex Note: Used in the AC/DC Drive Object	Default: 0 Range: -15~15
F6-58 (3D9)	Torque Scaling	Sets the scaling factor for the Torque Monitor in the DeviceNet Object Class 2A hex Note: Used in the AC/DC Drive Object	Default: 0 Range: -15~15
F6-59 (3DA)	Power Scaling	Sets the scaling factor for the Power Monitor in the DeviceNet Object Class 2A hex Note: Used in the AC/DC Drive Object	Default: 0 Range: -15~15
F6-60 (3DB)	Voltage Scaling	Sets the scaling factor for the Voltage Monitor in the DeviceNet Object Class 2A hex Note: Used in the AC/DC Drive Object	Default: 0 Range: -15~15
F6-61 (3DC)	Time Scaling	Sets the scaling factor for the Time Monitor in the DeviceNet Object Class 2A hex Note: Used in the AC/DC Drive Object	Default: 0 Range: -15~15
F6-62 (3DD)	Heart Beat	Sets the heartbeat interval Note: Used in the Identity Object	Default: 0 Range: 0~10
F6-63 (3DE) <6>	MAC ID from Network	(Read only) Actual MAC address Note: Used in the DeviceNet Object	Range: 0~63
U6-98 (7F8)	Previous Option Fault	Displays previous faulted status. 0: No fault 1: Option failure 2: PLC in idle state 3: Forcefault 1000: Network power loss 1001: Connection time-out 1002: Duplicate MAC ID 1003: Bus-Off Note: Used in DeviceNet Option Faults	Range: 0~3; 1000~1003

6 DeviceNet Option Drive Parameters

No. (Addr. Hex)	Name	Description	Values
U6-99 (7F9)	Current Option Fault	Displays the most recent fault status. 0: No fault 1: Option failure 2: PLC in idle state 3: Force fault 1000: Network power loss 1001: Connection time-out 1002: Duplicate MAC ID 1003: Bus-Off Note: Used in DeviceNet Option Faults	Range: 0~3; 1000~1003

- <1> To start and stop the drive with the DeviceNet master device using serial communications, set b1-02 to “3” or set the “Net Control” bit in the assemblies or Control Supervisor Object. To control the frequency reference of the drive via the master device, set b1-01 to “3” or set the “Net Reference” bit in the assemblies or AC/DC object.
- <2> If F6-01 or F6-03 is set to 3, then the drive will continue to operate when a fault is detected. Take proper safety measures, such as installing an emergency stop switch.
- <3> All MAC addresses must be unique.
- <4> Software version 1011 has a setting range of 0 to 63 with a default value of 63.
- <5> F6-51=3 and 4 are not possible in software version 1011. Default value is 3.
- <6> F6-55 and F6-63 are not available in software version 1011.
- <7> PCA and PPA will be initialized if unavailable values are set.
- <8> Software versions 1012 and later have F6-07 and F6-08 both set to 1.

7 Configuring DeviceNet Messaging

This section provides information on the various methods used to control the drive on DeviceNet.

◆ Drive Configuration on DeviceNet

■ Polled Configuration

The Drive DeviceNet Polled connection must be configured before receiving commands from a Master device. The two parameters that must be configured are:

- F6-52: Polled Consuming Assembly (PCA)
Note: Output assembly consumed by the drive.
- F6-53: Polled Producing Assembly (PPA)
Note: Input assembly produced by the drive.

The default connection paths for the DeviceNet Option are set for Extended Speed Control.

The PCA and PPA parameters can be accessed by two methods.

- A software configuration tool (not supplied), and Yaskawa Electronic Data Sheet (EDS)
Note: The PCA and PPA parameters can be accessed from the “DN: Polled Config” parameter group.
- A software configuration tool (not supplied), via a DeviceNet message path, such as (Extended Speed Control)
Note: Use DeviceNet Connection Object to change the PCA or PPA if required by the application (Class 5, Instance 1, Attributes 14 and 16)

One each PCA and PPA assembly from the following table must be selected to configure the drive for polled operation.

Table 10 Supported Polled Assemblies (PCA and PPA)

Assembly Number (decimal)	Description	Type	Bytes	Page
20	<i>Basic Speed Control Output - 20 (0x14)</i>	PCA	4	26
21	<i>Extended Speed Control Output - 21 (0x15)</i> (Default Setting)	PCA	4	27
22	<i>Speed and Torque Control Output - 22 (0x16)</i>	PCA	6	28
23	<i>Extended Speed and Torque Control Output - 23 (0x17)</i>	PCA	6	29
70	<i>Basic Speed Control Input - 70 (0x46)</i>	PPA	4	47
71	<i>Extended Speed Control Input - 71 (0x47)</i> (Default Setting)	PPA	4	48
72	<i>Speed and Torque Control Input - 72 (0x48)</i>	PPA	6	49
73	<i>Extended Speed and Torque Control Input - 73 (0x49)</i>	PPA	6	50
100	<i>MEMOBUS/Modbus Message Command (Vendor Specific YE Assy) - 100 (0x64)</i>	PCA	5	30
101	<i>Standard Control (Vendor Specific YE Assy) - 101 (0x65)</i>	PCA	8	31
102	<i>Accel/Decel Time (Vendor Specific YE Assy) - 102 (0x66)</i>	PCA	8	32
105	<i>Enhanced Speed Control, Dynamic (Vendor Specific YE Assy) - 105 (0x69)</i>	PCA	8	34
106	<i>Enhanced Control (Vendor Specific YE Assy) - 106 (0x6A)</i>	PCA	8	36
107	<i>Standard DI/DO Control (Vendor Specific YE Assy) - 107 (0x6B)</i>	PCA	8	37
108	<i>Enhanced Torque Control, Dynamic (Vendor Specific YE Assy) - 108 (0x6C)</i>	PCA	8	38
120	<i>Speed Command 1 (Vendor Specific YE Assy) - 120 (0x78)</i>	PCA	4	40
121	<i>Torque Command 1 (Vendor Specific YE Assy) - 121 (0x79)</i>	PCA	4	41
122	<i>Speed Command 2 (Vendor Specific YE Assy) - 122 (0x7A)</i>	PCA	6	42
123	<i>Torque Command 2 (Vendor Specific YE Assy) - 123 (0x7B)</i>	PCA	6	43
124	<i>Speed Dynamic Assy (Vendor Specific YE Assy) - 124 (0x7C)</i>	PCA	8	44
125	<i>Torque Dynamic Assy (Vendor Specific YE Assy) - 125 (0x7D)</i>	PCA	8	45
126	<i>Speed/Torque Assy (Vendor Specific YE Assy) - 126 (0x7E)</i>	PCA	8	46
130	<i>Speed Status (Vendor Specific YE Assy) - 130 (0x82)</i>	PPA	4	51
131	<i>Current Status (Vendor Specific YE Assy) - 131 (0x83)</i>	PPA	4	52
132	<i>Current & Speed Status (Vendor Specific YE Assy) - 132 (0x84)</i>	PPA	6	53
134	<i>Speed Status Dynamic Assy (Vendor Specific YE Assy) - 134 (0x86)</i>	PPA	8	54

7 Configuring DeviceNet Messaging

Assembly Number (decimal)	Description	Type	Bytes	Page
135	<i>Current Status Dynamic Assy (Vendor Specific YE Assy) - 135 (0x87)</i>	PPA	8	55
136	<i>Torque and Speed Status (Vendor Specific YE Assy) - 136 (0x88)</i>	PPA	8	57
150	<i>MEMOBUS/Modbus Message Reply (Vendor Specific YE Assy) - 150 (0x96)</i>	PPA	5	58
151	<i>Standard Status 1 (Vendor Specific YE Assy) - 151 (0x97)</i>	PPA	8	59
152	<i>Standard Status 2 (Vendor Specific YE Assy) -152 (0x98)</i>	PPA	8	60
155	<i>Enhanced Speed Status, Dynamic (Vendor Specific YE Assy) - 155 (0x9B)</i>	PPA	8	62
156	<i>Enhanced Control Status (Vendor Specific YE Assy) -156 (0x9C)</i>	PPA	8	64
157	<i>Standard DI/DO Status (Vendor Specific YE Assy) - 157 (0x9D)</i>	PPA	8	65
158	<i>Enhanced Torque Status, Dynamic (Vendor Specific YE Assy) - 158 (0x9E)</i>	PPA	8	67
199	<i>Change of State Response (Vendor Specific YE Assy) - 199 (0xC7)</i>	PPA	8	69

<1> Torque Control is not available in the V1000 drive.

8 DeviceNet Option Details

◆ Support Message Type

Explicit Messages: Fragmentation is supported. Up to 32 Bytes can be input and output.

Polled I/O Messages: Fragmentation is not supported. Up to 8 Bytes can be input and output.

COS Messages: Fragmentation is not supported.

Faulted Node Recovery / Offline Connection Set Messages

◆ Support Connection Path Type

Logical encoding is used for the Polled Consumed and Produced connection paths. To support application tools and development tools that do not handle explicit message fragmentation this option supports Symbolic encoding. Symbolic encoding only requires a 3 byte long message where logical encoding requires eleven bytes. This option has a third method of setting Polled Consumed and Produced connection paths. Class 5, Instance 2, Attributes (100, 101) allow setting connection path with a single byte. For instance, to set the Consumed connection path to 100, write 100 (0x64) to Attribute 101. See appendix C of "The CIP Networks Library, Volume 1" for more information on CIP segments.

9 Output Assemblies (Drive Consumes)

Note: The convention in this manual is from the PLC perspective. As such, an assembly is called an “Output Assembly” when outputted from the PLC and received by this node. An “Input Assembly” is outputted from this node and read by the PLC. This section details “Output Assemblies” that are “Consumed” by this drive.

◆ Basic Speed Control Output - 20 (0x14)

Output Instance	Byte	Bit 7	Bit 6	Bit 5	Bit 4	Bit 3	Bit 2	Bit 1	Bit 0
20	0	-	-	-	-	-	Fault Reset	-	Run Fwd
	1	-							
	2	Speed Reference (Low Byte)							
	3	Speed Reference (High Byte)							

Name	Description
Run Fwd	Forward Run Command 0: Stop 1: Forward Run
Fault Reset	Fault Reset 0: No Fault Reset 1: Fault Reset
Speed Reference	Speed Command Sets the Drive's speed reference. Speed reference data: Frequency reference $\times 2^{SS}$ (SS: Speed scale) Setting range: 0 to 0xFFFF For example, when setting a reference of 1024 with a speed scale of 2: Speed reference data = $1024 \times 2^2 = 4096 = 0x1000$ Unit depends on o1-03.

◆ Extended Speed Control Output - 21 (0x15)

Output Instance	Byte	Bit 7	Bit 6	Bit 5	Bit 4	Bit 3	Bit 2	Bit 1	Bit 0
21	0	–	Net Ref	Net Ctrl	–	–	Fault Reset	Run Rev	Run Fwd
	1	–							
	2	Speed Reference (Low Byte)							
	3	Speed Reference (High Byte)							

Name	Description
Run Fwd	Forward Run Command 0: Stop 1: Forward Run
Run Rev	Reverse Run Command 0: Stop 1: Reverse Run
Fault Reset	Fault Reset 0: No Fault Reset 1: Fault Reset
NetCtrl	Run command from Network 0: Depends on b1-02 1: Enables the run command from network
NetRef	Speed reference from Network 0: Depends on b1-01 1: Enables the speed reference from network
Speed Reference	Speed Command Sets the Drive's speed reference. Speed reference data: Frequency reference $\times 2^{SS}$ (SS: Speed scale) Setting range: 0 to 0xFFFF For example, when setting a reference of 1024 with a speed scale of 2: Speed reference data = $1024 \times 2^2 = 4096 = 0x1000$ Unit depends on o1-03.

9 Output Assemblies (Drive Consumes)

◆ Speed and Torque Control Output - 22 (0x16)

Output Instance	Byte	Bit 7	Bit 6	Bit 5	Bit 4	Bit 3	Bit 2	Bit 1	Bit 0
22	0	–	–	–	–	–	Fault Reset	–	Run Fwd
	1	–							
	2	Speed Reference (Low Byte)							
	3	Speed Reference (High Byte)							
	4	Torque Reference (Low Byte), not supported							
	5	Torque Reference (High Byte), not supported							

Name	Description
Run Fwd	Forward Run Command 0: Stop 1: Forward Run
Fault Reset	Fault Reset 0: No Fault Reset 1: Fault Reset
Speed Reference	Speed Command Sets the Drive's speed reference. Speed reference data: Frequency reference $\times 2^{SS}$ (SS: Speed scale) Setting range: 0 to 0xFFFF For example, when setting a reference of 1024 with a speed scale of 2: Speed reference data = $1024 \times 2^2 = 4096 = 0x1000$ Unit depends on o1-03.
Torque Reference	Not supported

◆ Extended Speed and Torque Control Output - 23 (0x17)

Output Instance	Byte	Bit 7	Bit 6	Bit 5	Bit 4	Bit 3	Bit 2	Bit 1	Bit 0
23	0	–	Net Ref	Net Ctrl	–	–	Fault Reset	Run Rev	Run Fwd
	1	–							
	2	Speed Reference (Low Byte)							
	3	Speed Reference (High Byte)							
	4	Torque Reference (Low Byte), not supported							
	5	Torque Reference (High Byte), not supported							

Name	Description
Run Fwd	Forward Run Command 0: Stop 1: Forward Run
Run Rev	Reverse Run Command 0: Stop 1: Reverse Run
Fault Reset	Fault Reset 0: No Fault Reset 1: Fault Reset
NetCtrl	Run command from Network 0: Depends on b1-02 1: Enables the run command from network
NetRef	Speed reference from Network 0: Depends on b1-01 1: Enables the speed reference from network
Speed Reference	Speed Command Sets the Drive's speed reference. Speed reference data: Frequency reference $\times 2^{SS}$ (SS: Speed scale) Setting range: 0 to 0xFFFF For example, when setting a reference of 1024 with a speed scale of 2 Speed reference data = $1024 \times 2^2 = 4096 = 0x1000$ Unit depends on o1-03.
Torque Reference	Not supported

9 Output Assemblies (Drive Consumes)

◆ MEMOBUS/Modbus Message Command (Vendor Specific YE Assy) - 100 (0x64)

Output Instance	Byte	Bit 7	Bit 6	Bit 5	Bit 4	Bit 3	Bit 2	Bit 1	Bit 0
100	0	Function Code							
	1	Register Number (High Byte)							
	2	Register Number (Low Byte)							
	3	Register Data (High Byte)							
	4	Register Data (Low Byte)							

Note: This is a paired assembly (100/150).

Name	Description
Function Code	MEMOBUS/Modbus Function Code <i>Refer to Function Code Decode Table on page 30.</i>
Register Number	MEMOBUS/Modbus Register Number
Register Data	MEMOBUS/Modbus Register Data

Table 11 Function Code Decode Table

Function Code	MEMOBUS/Modbus Function
0x00	No Operation
0x03	Read Register
0x10	Write Register

Note: Refer to the MEMOBUS/Modbus Data Table in Appendix C of the V1000 Technical Manual for a list of monitor data using the MEMOBUS/Modbus message area.

◆ Standard Control (Vendor Specific YE Assy) - 101 (0x65)

Output Instance	Byte	Bit 7	Bit 6	Bit 5	Bit 4	Bit 3	Bit 2	Bit 1	Bit 0
101	0	–	Multi-Function Input 7	Multi-Function Input 6	Multi-Function Input 5	Multi-Function Input 4	Multi-Function Input 3	Run Rev	Run Fwd
	1	Multi-Function Photo Coupler 2	Multi-Function Photo Coupler 1	Multi-Function Digital Output	–	–	–	Fault Reset	External Fault
	2	Speed Reference (Low Byte)							
	3	Speed Reference (High Byte)							
	4	Torque Reference (Low Byte), not supported							
	5	Torque Reference (High Byte), not supported							
	6	Torque Compensation (Low Byte), not supported							
	7	Torque Compensation (High Byte), not supported							

Output Instance	Byte
Run Fwd	Forward Run Command 0: Stop 1: Forward Run
Run Rev	Reverse Run Command 0: Stop 1: Reverse Run
Multi-Function Input 3	Terminal S3 Function Input 0: Terminal S3 Function (H1-03) OFF 1: Terminal S3 Function (H1-03) ON
Multi-Function Input 4	Terminal S4 Function Input 0: Terminal S4 Function (H1-04) OFF 1: Terminal S4 Function (H1-04) ON
Multi-Function Input 5	Terminal S5 Function Input 0: Terminal S5 Function (H1-05) OFF 1: Terminal S5 Function (H1-05) ON
Multi-Function Input 6	Terminal S6 Function Input 0: Terminal S6 Function (H1-06) OFF 1: Terminal S6 Function (H1-06) ON
Multi-Function Input 7	Terminal S7 Function Input 0: Terminal S7 Function (H1-07) OFF 1: Terminal S7 Function (H1-07) ON
External Fault	External Fault EF0 0: No External Fault (EF0) 1: External Fault (EF0)
Fault Reset	Fault Reset 0: No Fault Reset 1: Fault Reset
Multi-Function Digital Output	Terminal MA/MB 0: MA/MB OFF 1: MA/MB ON This function is enabled only when H2-01 is set to F.
Multi-Function Photo Coupler 1	Terminal P1 0: P1 OFF 1: P1 ON This function is enabled only when H2-02 is set to F.
Multi-Function Photo Coupler 2	Terminal P2 0: P2 OFF 1: P2 ON This function is enabled only when H2-03 is set to F.

9 Output Assemblies (Drive Consumes)

Output Instance	Byte
Speed Reference	Speed Command Sets the Drive's speed reference. Unit depends on o1-03. Unit is not affected by Speed Scale SS.
Torque Reference	Not supported
Torque Compensation	Not supported

◆ Accel/Decel Time (Vendor Specific YE Assy) - 102 (0x66)

Output Instance	Byte	Bit 7	Bit 6	Bit 5	Bit 4	Bit 3	Bit 2	Bit 1	Bit 0
102	0	–	Multi-Function Input 7	Multi-Function Input 6	Multi-Function Input 5	Multi-Function Input 4	Multi-Function Input 3	Run Rev	Run Fwd
	1	Multi-Function Photo Coupler 2	Multi-Function Photo Coupler 1	Multi-Function Digital Output	–	–	–	Fault Reset	External Fault
	2	Speed Reference (Low Byte)							
	3	Speed Reference (High Byte)							
	4	Acceleration Time 1 (Low Byte)							
	5	Acceleration Time 1 (High Byte)							
	6	Deceleration Time 1 (Low Byte)							
	7	Deceleration Time 1 (High Byte)							

Parameter	Data
Run Fwd	Forward Run Command 0: Stop 1: Forward Run
Run Rev	Reverse Run Command 0: Stop 1: Reverse Run
Multi-Function Input 3	Terminal S3 Function Input 0: Terminal S3 Function (H1-03) OFF 1: Terminal S3 Function (H1-03) ON
Multi-Function Input 4	Terminal S4 Function Input 0: Terminal S4 Function (H1-04) OFF 1: Terminal S4 Function (H1-04) ON
Multi-Function Input 5	Terminal S5 Function Input 0: Terminal S5 Function (H1-05) OFF 1: Terminal S5 Function (H1-05) ON
Multi-Function Input 6	Terminal S6 Function Input 0: Terminal S6 Function (H1-06) OFF 1: Terminal S6 Function (H1-06) ON
Multi-Function Input 7	Terminal S7 Function Input 0: Terminal S7 Function (H1-07) OFF 1: Terminal S7 Function (H1-07) ON
External Fault	External Fault EF0 0: No External Fault (EF0) 1: External Fault (EF0)
Fault Reset	Fault Reset 0: No Fault Reset 1: Fault Reset

9 Output Assemblies (Drive Consumes)

Parameter	Data
Multi-Function Digital Output	Terminal MA/MB 0: MA/MB OFF 1: MA/MB ON This function is enabled only when H2-01 is set to F.
Multi-Function Photo Coupler 1	Terminal P1 0: P1 OFF 1: P1 ON This function is enabled only when H2-02 is set to F.
Multi-Function Photo Coupler 2	Terminal P2 0: P2 OFF 1: P2 ON This function is enabled only when H2-03 is set to F.
Speed Reference	Speed Command Sets the Drive's speed reference. Unit depends on o1-03. Unit is not affected by Speed Scale SS.
Acceleration Time 1	Acceleration Time 1 (C1-01) Unit depends on C1-10. Unit is not affected by Time Scale TS.
Deceleration Time 1	Deceleration Time 1 (C1-02) Unit depends on C1-10. Unit is not affected by Time Scale TS.

9 Output Assemblies (Drive Consumes)

◆ Enhanced Speed Control, Dynamic (Vendor Specific YE Assy) - 105 (0x69)

Output Instance	Byte	Bit 7	Bit 6	Bit 5	Bit 4	Bit 3	Bit 2	Bit 1	Bit 0
105	0	–	Multi-Function Input 7	Multi-Function Input 6	Multi-Function Input 5	Multi-Function Input 4	Multi-Function Input 3	Run Rev	Run Fwd
	1	Multi-Function Photo-coupler 2	Multi-Function Photo-coupler 1	Multi-Function Digital Output	–	Function Code High Bit	Function Code Low Bit	Fault Reset	External Fault
	2	Speed Reference (Low Byte)							
	3	Speed Reference (High Byte)							
	4	Register Number (Low Byte)							
	5	Register Number (High Byte)							
	6	Register Data (Low Byte)							
	7	Register Data (High Byte)							

Name	Description
Run Fwd	Forward Run Command 0: Stop 1: Forward Run
Run Rev	Reverse Run Command 0: Stop 1: Reverse Run
Multi-Function Input 3	Terminal S3 Function Input 0: Terminal S3 Function (H1-03) OFF 1: Terminal S3 Function (H1-03) ON
Multi-Function Input 4	Terminal S4 Function Input 0: Terminal S4 Function (H1-04) OFF 1: Terminal S4 Function (H1-04) ON
Multi-Function Input 5	Terminal S5 Function Input 0: Terminal S5 Function (H1-05) OFF 1: Terminal S5 Function (H1-05) ON
Multi-Function Input 6	Terminal S6 Function Input 0: Terminal S6 Function (H1-06) OFF 1: Terminal S6 Function (H1-06) ON
Multi-Function Input 7	Terminal S7 Function Input 0: Terminal S7 Function (H1-07) OFF 1: Terminal S7 Function (H1-07) ON
External Fault	External Fault EF0 0: No External Fault (EF0) 1: External Fault (EF0)
Fault Reset	Fault Reset 0: No Fault Reset 1: Fault Reset
Function Code	MEMOBUS/Modbus Function Code <i>Refer to Function Code Decode Table on page 35.</i>
Multi-Function Digital Output	Terminal MA/MB 0: MA/MB OFF 1: MA/MB ON This function is enabled only when H2-01 is set to F.
Multi-Function Photo Coupler 1	Terminal P1 0: P1 OFF 1: P1 ON This function is enabled only when H2-02 is set to F.

Name	Description
Multi-Function Photo Coupler 2	Terminal P2 0: P2 OFF 1: P2 ON This function is enabled only when H2-03 is set to F.
Speed Reference	Speed Command Sets the Drive's speed reference. Unit depends on o1-03. Unit is not affected by Speed Scale SS.
Register Number	MEMOBUS/Modbus Register Number </>
Register Data	MEMOBUS/Modbus Register Data

<1> Register numbers 0x0001, 0x0002, and 0x0009 are disabled.

Note: This is a paired assembly (105/155).

Table 12 Function Code Decode Table

Function Code High Byte - Low Byte	MEMOBUS/Modbus Function
0 0	No Operation
1 0	Read Register
0 1	Write Register
1 1	No Operation

Note: Refer to the MEMOBUS/Modbus Data Table in Appendix C of the V1000 Technical Manual for a list of monitor data using the MEMOBUS/Modbus message area.

9 Output Assemblies (Drive Consumes)

◆ Enhanced Control (Vendor Specific YE Assy) - 106 (0x6A)

Output Instance	Byte	Bit 7	Bit 6	Bit 5	Bit 4	Bit 3	Bit 2	Bit 1	Bit 0
106	0	–	Multi-Function Input 7	Multi-Function Input 6	Multi-Function Input 5	Multi-Function Input 4	Multi-Function Input 3	Run Rev	Run Fwd
	1	Multi-Function Photo Coupler 2	Multi-Function Photo Coupler 1	Multi-Function Digital Output	–	–	–	Fault Reset	External Fault
	2	Speed Reference (Low Byte)							
	3	Speed Reference (High Byte)							
	4	–							
	5	–							
	6	–							
	7	–							

Parameter	Data
Run Fwd	Forward Run Command 0: Stop 1: Forward Run
Run Rev	Reverse Run Command 0: Stop 1: Reverse Run
Multi-Function Input 3	Terminal S3 Function Input 0: Terminal S3 Function (H1-03) OFF 1: Terminal S3 Function (H1-03) ON
Multi-Function Input 4	Terminal S4 Function Input 0: Terminal S4 Function (H1-04) OFF 1: Terminal S4 Function (H1-04) ON
Multi-Function Input 5	Terminal S5 Function Input 0: Terminal S5 Function (H1-05) OFF 1: Terminal S5 Function (H1-05) ON
Multi-Function Input 6	Terminal S6 Function Input 0: Terminal S6 Function (H1-06) OFF 1: Terminal S6 Function (H1-06) ON
Multi-Function Input 7	Terminal S7 Function Input 0: Terminal S7 Function (H1-07) OFF 1: Terminal S7 Function (H1-07) ON
External Fault	External Fault EF0 0: No External Fault (EF0) 1: External Fault (EF0)
Fault Reset	Fault Reset 0: No Fault Reset 1: Fault Reset
Multi-Function Digital Output	Terminal MA/MB 0: MA/MB OFF 1: MA/MB ON This function is enabled only when H2-01 is set to F.
Multi-Function Photo Coupler 1	Terminal P1 0: P1 OFF 1: P1 ON This function is enabled only when H2-02 is set to F.
Multi-Function Photo Coupler 2	Terminal P2 0: P2 OFF 1: P2 ON This function is enabled only when H2-03 is set to F.

Parameter	Data
Speed Reference	Speed Command Sets the Drive's speed reference. Unit depends on o1-03. Unit is not affected by Speed Scale SS.

◆ Standard DI/DO Control (Vendor Specific YE Assy) - 107 (0x6B)

Output Instance	Byte	Bit 7	Bit 6	Bit 5	Bit 4	Bit 3	Bit 2	Bit 1	Bit 0	
107	0	–	Multi-Function Input 7	Multi-Function Input 6	Multi-Function Input 5	Multi-Function Input 4	Multi-Function Input 3	Run Rev	Run Fwd	
	1	–	–	–	–	–	–	Fault Reset	External Fault	
	2	–	–	Multi-Function Photo Coupler 2	Multi-Function Photo Coupler 1	Multi-Function Digital Output	–	–	–	
	3	–	–	–	–	–	–	–	–	
	4	Analog Output 1 (Low Byte)								
	5	Analog Output 1 (High Byte)								
	6	Speed Reference (Low Byte)								
	7	Speed Reference (High Byte)								

Parameter	Data
Run Fwd	Forward Run Command 0: Stop 1: Forward Run
Run Rev	Reverse Run Command 0: Stop 1: Reverse Run
Multi-Function Input 3	Terminal S3 Function Input 0: Terminal S3 Function (H1-03) OFF 1: Terminal S3 Function (H1-03) ON
Multi-Function Input 4	Terminal S4 Function Input 0: Terminal S4 Function (H1-04) OFF 1: Terminal S4 Function (H1-04) ON
Multi-Function Input 5	Terminal S5 Function Input 0: Terminal S5 Function (H1-05) OFF 1: Terminal S5 Function (H1-05) ON
Multi-Function Input 6	Terminal S6 Function Input 0: Terminal S6 Function (H1-06) OFF 1: Terminal S6 Function (H1-06) ON
Multi-Function Input 7	Terminal S7 Function Input 0: Terminal S7 Function (H1-07) OFF 1: Terminal S7 Function (H1-07) ON
External Fault	External Fault EF0 0: No External Fault (EF0) 1: External Fault (EF0)
Fault Reset	Fault Reset 0: No Fault Reset 1: Fault Reset
Multi-Function Digital Output	Terminal MA/MB 0: MA/MB OFF 1: MA/MB ON This function is enabled only when H2-01 is set to F.

9 Output Assemblies (Drive Consumes)

Parameter	Data
Multi-Function Photo Coupler 1	Terminal P1 0: P1 OFF 1: P1 ON This function is enabled only when H2-02 is set to F.
Multi-Function Photo Coupler 2	Terminal P2 0: P2 OFF 1: P2 ON This function is enabled only when H2-03 is set to F.
Analog Output 1	Analog Output AM This function is enabled only when H4-01 is set to 000.
Speed Reference	Speed Command Sets the Drive's speed reference. Unit depends on o1-03. Unit is not affected by Speed Scale SS.

◆ Enhanced Torque Control, Dynamic (Vendor Specific YE Assy) - 108 (0x6C)

Output Instance	Byte	Bit 7	Bit 6	Bit 5	Bit 4	Bit 3	Bit 2	Bit 1	Bit 0
108	0	–	Multi-Function Input 7	Multi-Function Input 6	Multi-Function Input 5	Multi-Function Input 4	Multi-Function Input 3	Run Rev	Run Fwd
	1	Multi-Function Photo-coupler 2	Multi-Function Photo-coupler 1	Multi-Function Digital Output	–	Function Code High Bit	Function Code Low Bit	Fault Reset	External Fault
	2	Torque Reference (Low Byte), not supported							
	3	Torque Reference (High Byte), not supported							
	4	Register Number (Low Byte)							
	5	Register Number (High Byte)							
	6	Register Data (Low Byte)							
	7	Register Data (High Byte)							

Name	Description
Run Fwd	Forward Run Command 0: Stop 1: Forward Run
Run Rev	Reverse Run Command 0: Stop 1: Reverse Run
Multi-Function Input 3	Terminal S3 Function Input 0: Terminal S3 Function (H1-03) OFF 1: Terminal S3 Function (H1-03) ON
Multi-Function Input 4	Terminal S4 Function Input 0: Terminal S4 Function (H1-04) OFF 1: Terminal S4 Function (H1-04) ON
Multi-Function Input 5	Terminal S5 Function Input 0: Terminal S5 Function (H1-05) OFF 1: Terminal S5 Function (H1-05) ON
Multi-Function Input 6	Terminal S6 Function Input 0: Terminal S6 Function (H1-06) OFF 1: Terminal S6 Function (H1-06) ON
Multi-Function Input 7	Terminal S7 Function Input 0: Terminal S7 Function (H1-07) OFF 1: Terminal S7 Function (H1-07) ON

Name	Description
External Fault	External Fault EF0 0: No External Fault (EF0) 1: External Fault (EF0)
Fault Reset	Fault Reset 0: No Fault Reset 1: Fault Reset
Function Code	MEMOBUS/Modbus Function Code <i>Refer to Function Code Decode Table on page 35.</i>
Multi-Function Digital Output	Terminal MA/MB 0: MA/MB OFF 1: MA/MB ON This function is enabled only when H2-01 is set to F.
Multi-Function Photo Coupler 1	Terminal P1 0: P1 OFF 1: P1 ON This function is enabled only when H2-02 is set to F.
Multi-Function Photo Coupler 2	Terminal P2 0: P2 OFF 1: P2 ON This function is enabled only when H2-03 is set to F.
Torque Reference	Not supported
Register Number	MEMOBUS/Modbus Register Number <1>
Register Data	MEMOBUS/Modbus Register Data

<1> Register number 0x0001, and 0x0009 are disabled.

Note: This is a paired assembly (108/158).

Note: Refer to the MEMOBUS/Modbus Data Table in Appendix C of the V1000 Technical Manual for a list of monitor data using the MEMOBUS/Modbus message area.

9 Output Assemblies (Drive Consumes)

◆ Speed Command 1 (Vendor Specific YE Assy) - 120 (0x78)

Output Instance	Byte	Bit 7	Bit 6	Bit 5	Bit 4	Bit 3	Bit 2	Bit 1	Bit 0
120	0	–	Multi-Function Input 7	Multi-Function Input 6	Multi-Function Input 5	Multi-Function Input 4	Multi-Function Input 3	Run Rev	Run Fwd
	1	–	–	–	–	–	–	Fault Reset	External Fault
	2	Speed Reference (Low Byte)							
	3	Speed Reference (High Byte)							

Parameter	Data
Run Fwd	Forward Run Command 0: Stop 1: Forward Run
Run Rev	Reverse Run Command 0: Stop 1: Reverse Run
Multi-Function Input 3	Terminal S3 Function Input 0: Terminal S3 Function (H1-03) OFF 1: Terminal S3 Function (H1-03) ON
Multi-Function Input 4	Terminal S4 Function Input 0: Terminal S4 Function (H1-04) OFF 1: Terminal S4 Function (H1-04) ON
Multi-Function Input 5	Terminal S5 Function Input 0: Terminal S5 Function (H1-05) OFF 1: Terminal S5 Function (H1-05) ON
Multi-Function Input 6	Terminal S6 Function Input 0: Terminal S6 Function (H1-06) OFF 1: Terminal S6 Function (H1-06) ON
Multi-Function Input 7	Terminal S7 Function Input 0: Terminal S7 Function (H1-07) OFF 1: Terminal S7 Function (H1-07) ON
External Fault	External Fault EF0 0: No External Fault (EF0) 1: External Fault (EF0)
Fault Reset	Fault Reset 0: No Fault Reset 1: Fault Reset
Speed Reference	Speed Command Sets the Drive's speed reference. Unit depends on o1-03. Unit is not affected by Speed Scale SS.

◆ Torque Command 1 (Vendor Specific YE Assy) - 121 (0x79)

Output Instance	Byte	Bit 7	Bit 6	Bit 5	Bit 4	Bit 3	Bit 2	Bit 1	Bit 0
121	0	–	Multi-Function Input 7	Multi-Function Input 6	Multi-Function Input 5	Multi-Function Input 4	Multi-Function Input 3	Run Rev	Run Fwd
	1	–	–	–	–	–	–	Fault Reset	External Fault
	2	Torque Reference (Low Byte), not supported							
	3	Torque Reference (High Byte), not supported							

Parameter	Data
Run Fwd	Forward Run Command 0: Stop 1: Forward Run
Run Rev	Reverse Run Command 0: Stop 1: Reverse Run
Multi-Function Input 3	Terminal S3 Function Input 0: Terminal S3 Function (H1-03) OFF 1: Terminal S3 Function (H1-03) ON
Multi-Function Input 4	Terminal S4 Function Input 0: Terminal S4 Function (H1-04) OFF 1: Terminal S4 Function (H1-04) ON
Multi-Function Input 5	Terminal S5 Function Input 0: Terminal S5 Function (H1-05) OFF 1: Terminal S5 Function (H1-05) ON
Multi-Function Input 6	Terminal S6 Function Input 0: Terminal S6 Function (H1-06) OFF 1: Terminal S6 Function (H1-06) ON
Multi-Function Input 7	Terminal S7 Function Input 0: Terminal S7 Function (H1-07) OFF 1: Terminal S7 Function (H1-07) ON
External Fault	External Fault EF0 0: No External Fault (EF0) 1: External Fault (EF0)
Fault Reset	Fault Reset 0: No Fault Reset 1: Fault Reset
Torque Reference	Not supported

9 Output Assemblies (Drive Consumes)

◆ Speed Command 2 (Vendor Specific YE Assy) - 122 (0x7A)

Output Instance	Byte	Bit 7	Bit 6	Bit 5	Bit 4	Bit 3	Bit 2	Bit 1	Bit 0
122	0	–	Multi-Function Input 7	Multi-Function Input 6	Multi-Function Input 5	Multi-Function Input 4	Multi-Function Input 3	Run Rev	Run Fwd
	1	–	–	–	–	–	–	Fault Reset	External Fault
	2	Speed Reference (Low Byte)							
	3	Speed Reference (High Byte)							
	4	NetRef							
	5	NetCtrl							

Parameter	Data
Run Fwd	Forward Run Command 0: Stop 1: Forward Run
Run Rev	Reverse Run Command 0: Stop 1: Reverse Run
Multi-Function Input 3	Terminal S3 Function Input 0: Terminal S3 Function (H1-03) OFF 1: Terminal S3 Function (H1-03) ON
Multi-Function Input 4	Terminal S4 Function Input 0: Terminal S4 Function (H1-04) OFF 1: Terminal S4 Function (H1-04) ON
Multi-Function Input 5	Terminal S5 Function Input 0: Terminal S5 Function (H1-05) OFF 1: Terminal S5 Function (H1-05) ON
Multi-Function Input 6	Terminal S6 Function Input 0: Terminal S6 Function (H1-06) OFF 1: Terminal S6 Function (H1-06) ON
Multi-Function Input 7	Terminal S7 Function Input 0: Terminal S7 Function (H1-07) OFF 1: Terminal S7 Function (H1-07) ON
External Fault	External Fault EF0 0: No External Fault (EF0) 1: External Fault (EF0)
Fault Reset	Fault Reset 0: No Fault Reset 1: Fault Reset
Speed Reference	Speed Command Sets the Drive's speed reference. Unit depends on o1-03. Unit is not affected by Speed Scale SS.
NetRef	Speed reference form Network 0x00: Depends on b1-01 0x01: Enables the speed reference from network
NetCtrl	Run command form Network 0x00: Depends on b1-02 0x01: Enables the run command from network

◆ Torque Command 2 (Vendor Specific YE Assy) - 123 (0x7B)

Output Instance	Byte	Bit 7	Bit 6	Bit 5	Bit 4	Bit 3	Bit 2	Bit 1	Bit 0
123	0	–	Multi-Function Input 7	Multi-Function Input 6	Multi-Function Input 5	Multi-Function Input 4	Multi-Function Input 3	Run Rev	Run Fwd
	1	–	–	–	–	–	–	Fault Reset	External Fault
	2	Torque Reference (Low Byte), not supported							
	3	Torque Reference (High Byte), not supported							
	4	NetRef							
	5	NetCtrl							

Parameter	Data
Run Fwd	Forward Run Command 0: Stop 1: Forward Run
Run Rev	Reverse Run Command 0: Stop 1: Reverse Run
Multi-Function Input 3	Terminal S3 Function Input 0: Terminal S3 Function (H1-03) OFF 1: Terminal S3 Function (H1-03) ON
Multi-Function Input 4	Terminal S4 Function Input 0: Terminal S4 Function (H1-04) OFF 1: Terminal S4 Function (H1-04) ON
Multi-Function Input 5	Terminal S5 Function Input 0: Terminal S5 Function (H1-05) OFF 1: Terminal S5 Function (H1-05) ON
Multi-Function Input 6	Terminal S6 Function Input 0: Terminal S6 Function (H1-06) OFF 1: Terminal S6 Function (H1-06) ON
Multi-Function Input 7	Terminal S7 Function Input 0: Terminal S7 Function (H1-07) OFF 1: Terminal S7 Function (H1-07) ON
External Fault	External Fault EF0 0: No External Fault (EF0) 1: External Fault (EF0)
Fault Reset	Fault Reset 0: No Fault Reset 1: Fault Reset
Torque Reference	Not supported
NetRef	Speed reference from Network 0x00: Depends on b1-01 0x01: Enables the speed reference from network
NetCtrl	Run command from Network 0x00: Depends on b1-02 0x01: Enables the run command from network

9 Output Assemblies (Drive Consumes)

◆ Speed Dynamic Assy (Vendor Specific YE Assy) - 124 (0x7C)

Output Instance	Byte	Bit 7	Bit 6	Bit 5	Bit 4	Bit 3	Bit 2	Bit 1	Bit 0
124	0	–	Multi-Function Input 7	Multi-Function Input 6	Multi-Function Input 5	Multi-Function Input 4	Multi-Function Input 3	Run Rev	Run Fwd
	1	Service Code							
	2	Class							
	3	Attribute							
	4	Data (Low Byte)							
	5	Data (High Byte)							
	6	Speed Reference (Low Byte)							
	7	Speed Reference (High Byte)							

Parameter	Data
Run Fwd	Forward Run Command 0: Stop 1: Forward Run
Run Rev	Reverse Run Command 0: Stop 1: Reverse Run
Multi-Function Input 3	Terminal S3 Function Input 0: Terminal S3 Function (H1-03) OFF 1: Terminal S3 Function (H1-03) ON
Multi-Function Input 4	Terminal S4 Function Input 0: Terminal S4 Function (H1-04) OFF 1: Terminal S4 Function (H1-04) ON
Multi-Function Input 5	Terminal S5 Function Input 0: Terminal S5 Function (H1-05) OFF 1: Terminal S5 Function (H1-05) ON
Multi-Function Input 6	Terminal S6 Function Input 0: Terminal S6 Function (H1-06) OFF 1: Terminal S6 Function (H1-06) ON
Multi-Function Input 7	Terminal S7 Function Input 0: Terminal S7 Function (H1-07) OFF 1: Terminal S7 Function (H1-07) ON
Service Code	Service Code <i>Refer to Service Code Decode Table on page 44</i>
Class	Class Valid Classes are Control Supervisor Object (41) and AC/DC Object (42). Instance will always be 1.
Attribute	Attribute
Data	Data
Speed Reference	Speed Command Sets the Drive's speed reference. Unit depends on o1-03. Unit is not affected by Speed Scale SS.

Note: This is a paired assembly (124/134).

Table 13 Service Code Decode Table

Service Code	Function
0x00	No Operation
0x0E	Get Attribute Single
0x10	Set Attribute Single

◆ Torque Dynamic Assy (Vendor Specific YE Assy) - 125 (0x7D)

Output Instance	Byte	Bit 7	Bit 6	Bit 5	Bit 4	Bit 3	Bit 2	Bit 1	Bit 0
125	0	–	Multi-Function Input 7	Multi-Function Input 6	Multi-Function Input 5	Multi-Function Input 4	Multi-Function Input 3	Run Rev	Run Fwd
	1	Function Code							
	2	Class							
	3	Attribute							
	4	Data (Low Byte)							
	5	Data (High Byte)							
	6	Torque Reference (Low Byte), not supported							
	7	Torque Reference (High Byte), not supported							

Parameter	Data
Run Fwd	Forward Run Command 0: Stop 1: Forward Run
Run Rev	Reverse Run Command 0: Stop 1: Reverse Run
Multi-Function Input 3	Terminal S3 Function Input 0: Terminal S3 Function (H1-03) OFF 1: Terminal S3 Function (H1-03) ON
Multi-Function Input 4	Terminal S4 Function Input 0: Terminal S4 Function (H1-04) OFF 1: Terminal S4 Function (H1-04) ON
Multi-Function Input 5	Terminal S5 Function Input 0: Terminal S5 Function (H1-05) OFF 1: Terminal S5 Function (H1-05) ON
Multi-Function Input 6	Terminal S6 Function Input 0: Terminal S6 Function (H1-06) OFF 1: Terminal S6 Function (H1-06) ON
Multi-Function Input 7	Terminal S7 Function Input 0: Terminal S7 Function (H1-07) OFF 1: Terminal S7 Function (H1-07) ON
Service Code	Service Code <i>Refer to Service Code Decode Table on page 44</i>
Class	Class Valid Classes are Control Supervisor Object (41) and AC/DC Object (42). Instance will always be 1.
Attribute	Attribute
Data	Data
Torque Reference	Not supported

Note: This is a paired assembly (125/135).

9 Output Assemblies (Drive Consumes)

◆ Speed/Torque Assy (Vendor Specific YE Assy) - 126 (0x7E)

Output Instance	Byte	Bit 7	Bit 6	Bit 5	Bit 4	Bit 3	Bit 2	Bit 1	Bit 0
126	0	–	Multi-Function Input 7	Multi-Function Input 6	Multi-Function Input 5	Multi-Function Input 4	Multi-Function Input 3	Run Rev	Run Fwd
	1	–	–	–	–	–	–	Fault Reset	External Fault
	2	Speed Reference (Low Byte)							
	3	Speed Reference (High Byte)							
	4	Torque Reference (Low Byte), not supported							
	5	Torque Reference (High Byte), not supported							
	6	Torque Compensation (Low Byte), not supported							
	7	Torque Compensation (High Byte), not supported							

Parameter	Data
Run Fwd	Forward Run Command 0: Stop 1: Forward Run
Run Rev	Reverse Run Command 0: Stop 1: Reverse Run
Multi-Function Input 3	Terminal S3 Function Input 0: Terminal S3 Function (H1-03) OFF 1: Terminal S3 Function (H1-03) ON
Multi-Function Input 4	Terminal S4 Function Input 0: Terminal S4 Function (H1-04) OFF 1: Terminal S4 Function (H1-04) ON
Multi-Function Input 5	Terminal S5 Function Input 0: Terminal S5 Function (H1-05) OFF 1: Terminal S5 Function (H1-05) ON
Multi-Function Input 6	Terminal S6 Function Input 0: Terminal S6 Function (H1-06) OFF 1: Terminal S6 Function (H1-06) ON
Multi-Function Input 7	Terminal S7 Function Input 0: Terminal S7 Function (H1-07) OFF 1: Terminal S7 Function (H1-07) ON
External Fault	External Fault EF0 0: No External Fault (EF0) 1: External Fault (EF0)
Fault Reset	Fault Reset 0: No Fault Reset 1: Fault Reset
Speed Reference	Speed Command Sets the Drive's speed reference. Unit depends on o1-03. Unit is not affected by Speed Scale SS.
Torque Reference	Not supported
Torque Compensation	Not supported

10 Input Assemblies (Drive Produces)

Note: The convention in this manual is from the PLC perspective. As such, an assembly is called an “Output Assembly” when outputted from the PLC and received by this node. An “Input Assembly” is outputted from this node and read by the PLC. This section details “Input Assemblies” that are “Produced” by this drive.

◆ Basic Speed Control Input - 70 (0x46)

Input Instance	Byte	Bit 7	Bit 6	Bit 5	Bit 4	Bit 3	Bit 2	Bit 1	Bit 0
70	0	–	–	–	–	–	Running 1 (FWD)	–	Faulted
	1	–							
	2	Speed Actual (Low Byte)							
	3	Speed Actual (High Byte)							

Parameter	Data
Faulted	Faulted 0: No Faults Occurred 1: Fault Occurred
Running1	Forward Running 0: Stop or Reverse Running 1: Forward Running
Speed Actual	Actual Drive Speed Monitored the Drive's output frequency. Speed actual data: Output frequency / 2 ^{SS} (SS: Speed scale) Range: 0 to 0xFFFF For example, when output frequency of 4096 with a speed scale of 2 Speed actual data = 4096 / 22 = 1024 = 0x0400 Unit depends on 01-03.

10 Input Assemblies (Drive Produces)

◆ Extended Speed Control Input - 71 (0x47)

Input Instance	Byte	Bit 7	Bit 6	Bit 5	Bit 4	Bit 3	Bit 2	Bit 1	Bit 0
71	0	At Speed	Ref from Net	Ctrl from Net	Ready	Running 2 (REV)	Running 1 (FWD)	Warning	Faulted
	1	-							
	2	Speed Actual (Low Byte)							
	3	Speed Actual (High Byte)							

Name	Description
Faulted	Faulted 0: No Faults Occurred 1: Fault Occurred
Warning	Warning 0: No Warning Occurred 1: Warning Occurred
Running 1 (FWD)	Forward Running 0: Stop or Reverse Running 1: Forward Running
Running 2 (REV)	Reverse Running 0: Stop or Forward Running 1: Reverse Running
Ready	Drive Ready 0: Not Ready 1: Ready
Ctrl from Net	Status of Run command from Network 0: Run command is not from network 1: Run command is from network
Ref from Net	Status of Speed reference from Network 0: Speed reference is not from network 1: Speed reference is from network
At Speed	Speed Agree 0: No Speed Agree 1: Actual speed at speed reference
Speed Actual	Actual Drive Speed Monitored the Drive's output frequency. Speed actual data: Output frequency / 2 ^{SS} (SS: Speed scale) Range: 0 to 0xFFFF For example, when output frequency of 4096 with a speed scale of 2 Speed actual data = 4096 / 2 ² = 1024 = 0x0400 Unit depends on o1-03.

◆ Speed and Torque Control Input - 72 (0x48)

Input Instance	Byte	Bit 7	Bit 6	Bit 5	Bit 4	Bit 3	Bit 2	Bit 1	Bit 0
72	0	-	-	-	-	-	Running 1 (FWD)	-	Faulted
	1	-							
	2	Speed Actual (Low Byte)							
	3	Speed Actual (High Byte)							
	4	Torque Actual (Low Byte), not supported							
	5	Torque Actual (High Byte), not supported							

Name	Description
Faulted	Faulted 0: No Faults Occurred 1: Fault Occurred
Running 1	Forward Running 0: Stop or Reverse Running 1: Forward Running
Speed Actual	Actual Drive Speed Monitored the Drive's output frequency. Speed actual data: Output frequency / 2 ^{SS} (SS: Speed scale) Range: 0 to 0xFFFF For example, when output frequency of 4096 with a speed scale of 2 Speed actual data = 4096 / 2 ² = 1024 = 0x0400 Unit depends on 01-03.
Torque Actual	Output Torque, not supported

10 Input Assemblies (Drive Produces)

◆ Extended Speed and Torque Control Input - 73 (0x49)

Input Instance	Byte	Bit 7	Bit 6	Bit 5	Bit 4	Bit 3	Bit 2	Bit 1	Bit 0
73	0	At Speed	Ref from Net	Ctrl from Net	Ready	Running 2 (REV)	Running 1 (FWD)	Warning	Faulted
	1	-							
	2	Speed Actual (Low Byte)							
	3	Speed Actual (High Byte)							
	4	Torque Actual (Low Byte), not supported							
	5	Torque Actual (High Byte), not supported							

Name	Description
1. Faulted	Faulted 0: No Faults Occurred 1: Fault Occurred
1. Warning	Warning 0: No Warning Occurred 1: Warning Occurred
1. Running 1 (FWD)	Forward Running 0: Stop or Reverse Running 1: Forward Running
1. Running 2 (REV)	Reverse Running 0: Stop or Forward Running 1: Reverse Running
1. Ready	Drive Ready 0: Not Ready 1: Ready
1. Ctrl from Net	Status of Run command from Network 0: Run command is not from network 1: Run command is from network
1. Ref from Net	Status of Speed reference from Network 0: Speed reference is not from network 1: Speed reference is from network
1. At Speed	Speed Agree 0: No Speed Agree 1: Actual speed at speed reference
1. Speed Actual	Actual Drive Speed Monitored the Drive's output frequency. Speed actual data: Output frequency / 2 ^{SS} (SS: Speed scale) Range: 0 to 0xFFFF For example, when output frequency of 4096 with a speed scale of 2 Speed actual data = 4096 / 2 ² = 1024 = 0x0400 Unit depends on o1-03.
1. Torque Actual	Output Torque, not supported

◆ Speed Status (Vendor Specific YE Assy) - 130 (0x82)

Input Instance	Byte	Bit 7	Bit 6	Bit 5	Bit 4	Bit 3	Bit 2	Bit 1	Bit 0
130	0	FAULT	ALARM	READY	Speed Agree	Reset	REV Running	ZSP	Running
	1	-	-	Multi-Function Photo Coupler 2	Multi-Function Photo Coupler 1	Multi-Function Digital Output	Local/Remote	UV	-
	2	Output Frequency (Low Byte)							
	3	Output Frequency (High Byte)							

Parameter	Data
Running	Running 0: Stop 1: Forward or Reverse Running
ZSP	Zero Speed 0: Running 1: Stop or DC Injection Braking
REV Running	Reverse Running 0: Not Reverse Running 1: Reverse Running
Reset	Reset 0: No Reset 1: Reset
Speed Agree	Speed Agree 0: No Speed Agree 1: Actual speed at speed reference
READY	Drive Ready 0: Not Ready 1: Ready
ALARM	Drive Alarm 0: No Drive Alarm 1: Alarm
FAULT	Drive Fault 0: No Drive Fault 1: Fault
UV	Under Voltage 0: No Under Voltage 1: Under Voltage
Local/Remote	Status of Run command from Network 0: Run command is not from network 1: Run command is from network
Multi-Function Digital Output	Terminal MA/MB 0: Terminal MA/MB OFF 1: Terminal MA/MB ON
Multi-Function Photo Coupler 1	Terminal P1 0: Terminal P1 OFF 1: Terminal P1 ON
Multi-Function Photo Coupler 2	Terminal P2 0: Terminal P2 OFF 1: Terminal P2 ON
Output Frequency	Actual Drive Speed Monitored the Drive's output frequency. Unit depends on o1-03. Unit is not affected by Speed Scale SS.

10 Input Assemblies (Drive Produces)

◆ Current Status (Vendor Specific YE Assy) - 131 (0x83)

Input Instance	Byte	Bit 7	Bit 6	Bit 5	Bit 4	Bit 3	Bit 2	Bit 1	Bit 0
131	0	FAULT	ALARM	READY	Speed Agree	Reset	REV Running	ZSP	Running
	1	-	-	Multi-Function Photo Coupler 2	Multi-Function Photo Coupler 1	Multi-Function Digital Output	Local/Remote	UV	-
	2	Actual Current (Low Byte)							
	3	Actual Current (High Byte)							

Parameter	Data
Running	Running 0: Stop 1: Forward or Reverse Running
ZSP	Zero Speed 0: Running 1: Stop or DC Injection Braking
REV Running	Reverse Running 0: Not Reverse Running 1: Reverse Running
Reset	Reset 0: No Reset 1: Reset
Speed Agree	Speed Agree 0: No Speed Agree 1: Actual speed at speed reference
READY	Drive Ready 0: Not Ready 1: Ready
ALARM	Drive Alarm 0: No Drive Alarm 1: Alarm
FAULT	Drive Fault 0: No Drive Fault 1: Fault
UV	Under Voltage 0: No Under Voltage 1: Under Voltage
Local/Remote	Status of Run command from Network 0: Run command is not from network 1: Run command is from network
Multi-Function Digital Output	Terminal MA/MB 0: Terminal MA/MB OFF 1: Terminal MA/MB ON
Multi-Function Photo Coupler 1	Terminal P1 0: Terminal P1 OFF 1: Terminal P1 ON
Multi-Function Photo Coupler 2	Terminal P2 0: Terminal P2 OFF 1: Terminal P2 ON
Actual Current	Actual Output Current Monitored the Drive's output current. Unit is 0.01 A for drives set up to 11 kW in Heavy Duty or Normal Duty and 0.1 A for drives set up for 15 kW and above. Unit is not affected by Current Scale CS.

◆ Current & Speed Status (Vendor Specific YE Assy) - 132 (0x84)

Input Instance	Byte	Bit 7	Bit 6	Bit 5	Bit 4	Bit 3	Bit 2	Bit 1	Bit 0
132	0	FAULT	ALARM	READY	Speed Agree	Reset	REV Running	ZSP	Running
	1	–	–	Multi-Function Photo Coupler 2	Multi-Function Photo Coupler 1	Multi-Function Digital Output	Local/Remote	UV	–
	2	Actual Current (Low Byte)							
	3	Actual Current (High Byte)							
	4	Output Frequency (Low Byte)							
	5	Output Frequency (High Byte)							

Parameter	Data
Running	Running 0: Stop 1: Forward or Reverse Running
ZSP	Zero Speed 0: Running 1: Stop or DC Injection Braking
REV Running	Reverse Running 0: Not Reverse Running 1: Reverse Running
Reset	Reset 0: No Reset 1: Reset
Speed Agree	Speed Agree 0: No Speed Agree 1: Actual speed at speed reference
READY	Drive Ready 0: Not Ready 1: Ready
ALARM	Drive Alarm 0: No Drive Alarm 1: Alarm
FAULT	Drive Fault 0: No Drive Fault 1: Fault
UV	Under Voltage 0: No Under Voltage 1: Under Voltage
Local/Remote	Status of Run command from Network 0: Run command is not from network 1: Run command is from network
Multi-Function Digital Output	Terminal MA/MB 0: Terminal MA/MB OFF 1: Terminal MA/MB ON
Multi-Function Photo Coupler 1	Terminal P1 0: Terminal P1 OFF 1: Terminal P1 ON
Multi-Function Photo Coupler 2	Terminal P2 0: Terminal P2 OFF 1: Terminal P2 ON

10 Input Assemblies (Drive Produces)

Parameter	Data
Actual Current	Actual Output Current Monitored the Drive's output current. Unit is 0.01 A for drives set up to 11 kW in Heavy Duty or Normal Duty and 0.1 A for drives set up for 15 kW and above. Unit is not affected by Current Scale CS.
Output Frequency	Actual Drive Speed Monitored the Drive's output frequency. Unit depends on o1-03. Unit is not affected by Speed Scale SS.

◆ Speed Status Dynamic Assy (Vendor Specific YE Assy) - 134 (0x86)

Input Instance	Byte	Bit 7	Bit 6	Bit 5	Bit 4	Bit 3	Bit 2	Bit 1	Bit 0
134	0	FAULT	ALARM	READY	Speed Agree	Reset	REV Running	ZSP	Running
	1	Service Code							
	2	Class							
	3	Attribute							
	4	Data (Low Byte)							
	5	Data (High Byte)							
	6	Output Frequency (Low Byte)							
	7	Output Frequency (High Byte)							

Parameter	Data
Running	Running 0: Stop 1: Forward or Reverse Running
ZSP	Zero Speed 0: Running 1: Stop or DC Injection Braking
REV Running	Reverse Running 0: Not Reverse Running 1: Reverse Running
Reset	Reset 0: No Reset 1: Reset
Speed Agree	Speed Agree 0: No Speed Agree 1: Actual speed at speed reference
READY	Drive Ready 0: Not Ready 1: Ready
ALARM	Drive Alarm 0: No Drive Alarm 1: Alarm
FAULT	Drive Fault 0: No Drive Fault 1: Fault
Service Code	Service Code <i>Refer to Service Code Decode Table on page 44</i>
Class	Class Valid Classes are Control Supervisor Object (41) and AC/DC Object (42). Instance will always be 1.
Attribute	Attribute

Parameter	Data
Data	Data If Service Code is 0x94, Data is Error Code.
Output Frequency	Actual Drive Speed Monitored the Drive's output frequency. Unit depends on o1-03. Unit is not affected by Speed Scale SS.

Note: This is a paired assembly (124/134).

Table 14 Reply Mapping - 134

Byte	Write Success	Read Success	Write Failure	Read Failure	Busy	Illegal Function Code	Function Code Equals Zero
1	0x90	0x8E	0x94	0x94	0x8E/0x90	0x94	0
2	Class Number	Class Number	0	0	Class Number	0	0
3	Attribute Number	Attribute Number	0	0	Attribute Number	0	0
4	0	Data Low Byte	DeviceNet Error Code	DeviceNet Error Code	0	0x08	0
5	0	Data High Byte	0xFF	0xFF	0	0xFF	0

◆ Current Status Dynamic Assy (Vendor Specific YE Assy) - 135 (0x87)

Input Instance	Byte	Bit 7	Bit 6	Bit 5	Bit 4	Bit 3	Bit 2	Bit 1	Bit 0
135	0	FAULT	ALARM	READY	Speed Agree	Reset	REV Running	ZSP	Running
	1	Service Code							
	2	Class							
	3	Attribute							
	4	Data (Low Byte)							
	5	Data (High Byte)							
	6	Actual Current (Low Byte)							
	7	Actual Current (High Byte)							

Parameter	Data
Running	Running 0: Stop 1: Forward or Reverse Running
ZSP	Zero Speed 0: Running 1: Stop or DC Injection Braking
REV Running	Reverse Running 0: Not Reverse Running 1: Reverse Running
Reset	Reset 0: No Reset 1: Reset
Speed Agree	Speed Agree 0: No Speed Agree 1: Actual speed at speed reference
READY	Drive Ready 0: Not Ready 1: Ready

10 Input Assemblies (Drive Produces)

Parameter	Data
ALARM	Drive Alarm 0: No Drive Alarm 1: Alarm
FAULT	Drive Fault 0: No Drive Fault 1: Fault
Service Code	Service Code <i>Refer to Service Code Decode Table on page 44</i>
Class	Class Valid Classes are Control Supervisor Object (41) and AC/DC Object (42). Instance will always be 1.
Attribute	Attribute
Data	Data If Service Code is 0x94, Data is Error Code.
Actual Current	Actual Output Current Monitored the Drive's output current. Unit is 0.01 A for drives set up to 11 kW in Heavy Duty or Normal Duty and 0.1 A for drives set up for 15 kW and above. Unit is not affected by Current Scale CS.

Note: This is a paired assembly (125/135).

Table 15 Reply Mapping - 135

Byte	Write Success	Read Success	Write Failure	Read Failure	Busy	Illegal Function Code	Function Code Equals Zero
1	0x90	0x8E	0x94	0x94	0x8E/0x90	0x94	0
2	Class Number	Class Number	0	0	Class Number	0	0
3	Attribute Number	Attribute Number	0	0	Attribute Number	0	0
4	0	Data Low Byte	DeviceNet Error Code	DeviceNet Error Code	0	0x08	0
5	0	Data High Byte	0xFF	0xFF	0	0xFF	0

◆ Torque and Speed Status (Vendor Specific YE Assy) - 136 (0x88)

Input Instance	Byte	Bit 7	Bit 6	Bit 5	Bit 4	Bit 3	Bit 2	Bit 1	Bit 0
136	0	FAULT	ALARM	READY	Speed Agree	Reset	REV Running	ZSP	Running
	1	-	-	Multi-Function Photo Coupler 2	Multi-Function Photo Coupler 1	Multi-Function Digital Output	Local/Remote	UV	-
	2	Actual Torque (Low Byte), not supported							
	3	Actual Torque (High Byte), not supported							
	4	Output Frequency (Low Byte)							
	5	Output Frequency (High Byte)							
	6	Speed Reference (Low Byte)							
	7	Speed Reference (High Byte)							

Parameter	Data
Running	Running 0: Stop 1: Forward or Reverse Running
ZSP	Zero Speed 0: Running 1: Stop or DC Injection Braking
REV Running	Reverse Running 0: Not Reverse Running 1: Reverse Running
Reset	Reset 0: No Reset 1: Reset
Speed Agree	Speed Agree 0: No Speed Agree 1: Actual speed at speed reference
READY	Drive Ready 0: Not Ready 1: Ready
ALARM	Drive Alarm 0: No Drive Alarm 1: Alarm
FAULT	Drive Fault 0: No Drive Fault 1: Fault
UV	Under Voltage 0: No UV Fault 1: Fault
Local/Remote	Status of Run command from Network 0: Run command is not from network 1: Run command is from network
Multi-Function Digital Output	Terminal MA/MB 0: Terminal MA/MB OFF 1: Terminal MA/MB ON
Multi-Function Photo Coupler 1	Terminal P1 0: Terminal P1 OFF 1: Terminal P1 ON
Multi-Function Photo Coupler 2	Terminal P2 0: Terminal P2 OFF 1: Terminal P2 ON

10 Input Assemblies (Drive Produces)

Parameter	Data
Actual Torque	Output Torque, not supported
Output Frequency	Actual Drive Speed Monitored the Drive's output frequency. Unit depends on o1-03. Unit is not affected by Speed Scale SS.
Speed Reference	Frequency Reference Monitored the Drive's frequency reference. Unit depends on o1-03. Unit is not affected by Speed Scale SS.

◆ MEMOBUS/Modbus Message Reply (Vendor Specific YE Assy) - 150 (0x96)

Input Instance	Byte	Bit 7	Bit 6	Bit 5	Bit 4	Bit 3	Bit 2	Bit 1	Bit 0
150	0	Function Code							
	1	Register Number (High Byte)							
	2	Register Number (Low Byte)							
	3	Register Data (High Byte)							
	4	Register Data (Low Byte)							

Note: This is a paired assembly (100/150).

Table 16 Reply Mapping - 150

Byte	Write Success	Read Success	Write Failure	Read Failure	Illegal Function Code	Function Code Equals Zero
0	0x10	0x03	0x90	0x83	Function Code Or-ed with 0x80	0
1	Output Assembly Register Number (High Byte)	Output Assembly Register Number (High Byte)	Output Assembly Register Number (High Byte)	Output Assembly Register Number (High Byte)	Output Assembly Register Number (High Byte)	0
2	Output Assembly Register Number (Low Byte)	Output Assembly Register Number (Low Byte)	Output Assembly Register Number (Low Byte)	Output Assembly Register Number (Low Byte)	Output Assembly Register Number (Low Byte)	0
3	0	Read Data (High Byte)	0	0	0	0
4	0	Read Data (Low Byte)	Error Code	Error Code	1	0

Table 17 Error Replies - 150

Error Code	Description
0x01	Invalid Function Code
0x02	Invalid Register Number
0x21	Upper/Lower Limit Error
0x22	Option generated busy event. The MEMOBUS/Modbus requested operation is in the process loop but the drive is not done yet. Writing "Enter" when drive is running. Attempt to write data that is read only. Attempt to write a constant when drive is running. During a CPF06 event attempting to write to registers other than A1-00 to A1-05, E1-03, o2-04.
0x23	Attempting to write during a drive undervoltage (Uv) event.
0x24	Attempting to write while the drive is storing data.

Note: Refer to the MEMOBUS/Modbus Data Table in Appendix C of the V1000 Technical Manual for a list of monitor data using the MEMOBUS/Modbus message area.

◆ Standard Status 1 (Vendor Specific YE Assy) - 151 (0x97)

Output Instance	Byte	Bit 7	Bit 6	Bit 5	Bit 4	Bit 3	Bit 2	Bit 1	Bit 0
151	0	FAULT	ALARM	READY	Speed Agree	Reset	REV Running	ZSP	Running
	1	–	–	Multi-Function Photo Coupler 2	Multi-Function Photo Coupler 1	Multi-Function Digital Output	Local/Remote	UV	OPE
	2	Output Frequency (Low Byte)							
	3	Output Frequency (High Byte)							
	4	Actual Torque (Low Byte), not supported							
	5	Actual Torque (High Byte), not supported							
	6	Actual Current (Low Byte)							
	7	Actual Current (High Byte)							

Parameter	Data
Running	Running 0: Stop 1: Forward or Reverse Running
ZSP	Zero Speed 0: Running 1: Stop or DC Injection Braking
REV Running	Reverse Running 0: Not Reverse Running 1: Reverse Running
Reset	Reset 0: No Reset 1: Reset
Speed Agree	Speed Agree 0: No Speed Agree 1: Actual speed at speed reference
READY	Drive Ready 0: Not Ready 1: Ready
ALARM	Drive Alarm 0: No Drive Alarm 1: Alarm
FAULT	Drive Fault 0: No Drive Fault 1: Fault
OPE	OPE Fault 0: No OPExx Fault 1: OPExx
UV	Under Voltage 0: No Under Voltage 1: Under Voltage
Local/Remote	Status of Run command from Network 0: Run command is not from network 1: Run command is from network
Multi-Function Digital Output	Terminal MA/MB 0: Terminal MA/MB OFF 1: Terminal MA/MB ON
Multi-Function Photo Coupler 1	Terminal P1 0: Terminal P1 OFF 1: Terminal P1 ON

10 Input Assemblies (Drive Produces)

Parameter	Data
Multi-Function Photo Coupler 2	Terminal P2 0: Terminal P2 OFF 1: Terminal P2 ON
Output Frequency	Actual Drive Speed Monitored the Drive's output frequency. Unit depends on o1-03. Unit is not affected by Speed Scale SS.
Actual Torque	Output Torque, not supported
Actual Current	Actual Output Current Monitored the Drive's output current. Unit is 0.01 A for drives set up to 11 kW in Heavy Duty or Normal Duty and 0.1 A for drives set up for 15 kW and above. Unit is not affected by Current Scale CS.

◆ Standard Status 2 (Vendor Specific YE Assy) -152 (0x98)

Input Instance	Byte	Bit 7	Bit 6	Bit 5	Bit 4	Bit 3	Bit 2	Bit 1	Bit 0
152	0	FAULT	ALARM	READY	Speed Agree	Reset	REV Running	ZSP	Running
	1	-	-	Multi-Function Photo Coupler 2	Multi-Function Photo Coupler 1	Multi-Function Digital Output	Local/Remote	UV	OPE
	2	Output Frequency (Low Byte)							
	3	Output Frequency (High Byte)							
	4	Speed Reference (Low Byte)							
	5	Speed Reference (High Byte)							
	6	Actual Current (Low Byte)							
	7	Actual Current (High Byte)							

Parameter	Data
Running	Running 0: Stop 1: Forward or Reverse Running
ZSP	Zero Speed 0: Running 1: Stop or DC Injection Braking
REV Running	Reverse Running 0: Not Reverse Running 1: Reverse Running
Reset	Reset 0: No Reset 1: Reset
Speed Agree	Speed Agree 0: No Speed Agree 1: Actual speed at speed reference
READY	Drive Ready 0: Not Ready 1: Ready
ALARM	Drive Alarm 0: No Drive Alarm 1: Alarm
FAULT	Drive Fault 0: No Drive Fault 1: Fault

Parameter	Data
OPE	OPE Fault 0: No OPExx Fault 1: OPExx
UV	Under Voltage 0: No Under Voltage 1: Under Voltage
Local/Remote	Status of Run command from Network 0: Run command is not from network 1: Run command is from network
Multi-Function Digital Output	Terminal MA/MB 0: Terminal MA/MB OFF 1: Terminal MA/MB ON
Multi-Function Photo Coupler 1	Terminal P1 0: Terminal P1 OFF 1: Terminal P1 ON
Multi-Function Photo Coupler 2	Terminal P2 0: Terminal P2 OFF 1: Terminal P2 ON
Output Frequency	Actual Drive Speed Monitored the Drive's output frequency. Unit depends on o1-03. Unit is not affected by Speed Scale SS.
Frequency Reference	Frequency Reference Monitored the Drive's frequency reference. Unit depends on o1-03. Unit is not affected by Speed Scale SS.
Actual Current	Actual Output Current Monitored the Drive's output current. Unit is 0.01 A for drives set up to 11 kW in Heavy Duty or Normal Duty and 0.1 A for drives set up for 15 kW and above. Unit is not affected by Current Scale CS.

10 Input Assemblies (Drive Produces)

◆ Enhanced Speed Status, Dynamic (Vendor Specific YE Assy) - 155 (0x9B)

Output Instance	Byte	Bit 7	Bit 6	Bit 5	Bit 4	Bit 3	Bit 2	Bit 1	Bit 0
155	0	FAULT	ALARM	READY	Speed Agree	Reset	REV Running	ZSP	Running
	1	Multi-Function Photo Coupler 2	Multi-Function Photo Coupler 1	Multi-Function Digital Output	Local / Remote	Function Code High Bit	Function Code Low Bit	UV	OPE
	2	Output Frequency (Low Byte)							
	3	Output Frequency (High Byte)							
	4	Register Number (Low Byte)							
	5	Register Number (High Byte)							
	6	Register Data (Low Byte)							
	7	Register Data (High Byte)							

Parameter	Data
Running	Running 0: Stop 1: Forward or Reverse Running
ZSP	Zero Speed 0: Running 1: Stop or DC Injection Braking
REV Running	Reverse Running 0: Not Reverse Running 1: Reverse Running
Reset	Reset 0: No Reset 1: Reset
Speed Agree	Speed Agree 0: No Speed Agree 1: Actual speed at speed reference
READY	Drive Ready 0: Not Ready 1: Ready
ALARM	Drive Alarm 0: No Drive Alarm 1: Alarm
FAULT	Drive Fault 0: No Drive Fault 1: Fault
OPE	OPE Fault 0: No OPExx Fault 1: OPExx
UV	Under Voltage 0: No Under Voltage 1: Under Voltage
Function Code	MEMOBUS/Modbus Function Code <i>Refer to Function Code Decode Table on page 35</i>
Local/Remote	Status of Run command from Network 0: Run command is not from network 1: Run command is from network
Multi-Function Digital Output	Terminal MA/MB 0: Terminal MA/MB OFF 1: Terminal MA/MB ON
Multi-Function Photo Coupler 1	Terminal P1 0: Terminal P1 OFF 1: Terminal P1 ON

Parameter	Data
Multi-Function Photo Coupler 2	Terminal P2 0: Terminal P2 OFF 1: Terminal P2 ON
Output Frequency	Actual Drive Speed Monitored the Drive's output frequency. Unit depends on o1-03. Unit is not affected by Speed Scale SS.
Register Number	MEMOBUS/Modbus Register Number
Register Data	MEMOBUS/Modbus Register Data

Note: This is a paired assembly (105/155).

Note: Refer to the MEMOBUS/Modbus Data Table in Appendix C of the V1000 Technical Manual for a list of monitor data using the MEMOBUS/Modbus message area.

Table 18 Reply Mapping - 155

Function Code Bits/Byte	Write Success	Read Success	Write Failure	Read Failure	Function Code Equal to 0 0
Function Bits (High/Low)	1 1	1 1	0 1	0 1	0 0
4	Output Assembly Register Number (Low Byte)	Output Assembly Register Number (Low Byte)	Output Assembly Register Number (Low Byte)	Output Assembly Register Number (Low Byte)	0
5	Output Assembly Register Number (High Byte)	Output Assembly Register Number (High Byte)	Output Assembly Register Number (High Byte)	Output Assembly Register Number (High Byte)	0
6	0	Read Data (Low Byte)	Error Code	Error Code	0
7	0	Read Data (High Byte)	0	0	0

Table 19 Error Replies - 155

Error Code	Description
0x02	Invalid Register Number
0x21	Upper/Lower Limit Error
0x22	Option generated busy event. The MEMOBUS/Modbus requested operation is in the process loop but the drive is not done yet. Writing "Enter" when drive is running. Attempt to write data that is read only. Attempt to write a parameter when drive is running. During a CPF06 event attempting to write to registers other than A1-00 to A1-05, E1-03, o2-04.
0x23	Attempting to write during a drive undervoltage (Uv) event.
0x24	Attempting to write while the drive is storing data.

Note: Refer to the MEMOBUS/Modbus Data Table in Appendix C of the V1000 Technical Manual for a list of monitor data using the MEMOBUS/Modbus message area.

10 Input Assemblies (Drive Produces)

◆ Enhanced Control Status (Vendor Specific YE Assy) -156 (0x9C)

Input Instance	Byte	Bit 7	Bit 6	Bit 5	Bit 4	Bit 3	Bit 2	Bit 1	Bit 0
156	0	FAULT	ALARM	READY	Speed Agree	Reset	REV Running	ZSP	Running
	1	Multi-Function Photo Coupler 2	Multi-Function Photo Coupler 1	Multi-Function Digital Output	–	Multi-Function Input 4	Multi-Function Input 3	Multi-Function Input 2	Multi-Function Input 1
	2	Output Frequency (Low Byte)							
	3	Output Frequency (High Byte)							
	4	–							
	5	–							
	6	Actual Current (Low Byte)							
	7	Actual Current (High Byte)							

Parameter	Data
Running	Running 0: Stop 1: Forward or Reverse Running
ZSP	Zero Speed 0: Running 1: Stop or DC Injection Braking
REV Running	Reverse Running 0: Not Reverse Running 1: Reverse Running
Reset	Reset 0: No Reset 1: Reset
Speed Agree	Speed Agree 0: No Speed Agree 1: Actual speed at speed reference
READY	Drive Ready 0: Not Ready 1: Ready
ALARM	Drive Alarm 0: No Drive Alarm 1: Alarm
FAULT	Drive Fault 0: No Drive Fault 1: Fault
Multi-Function Input 1	Terminal S1 0: Terminal S1 OFF 1: Terminal S1 ON
Multi-Function Input 2	Terminal S2 0: Terminal S2 OFF 1: Terminal S2 ON
Multi-Function Input 3	Terminal S3 0: Terminal S3 OFF 1: Terminal S3 ON
Multi-Function Input 4	Terminal S4 0: Terminal S4 OFF 1: Terminal S4 ON
Multi-Function Digital Output	Terminal MA/MB 0: Terminal MA/MB OFF 1: Terminal MA/MB ON

Parameter	Data
Multi-Function Photo Coupler 1	Terminal P1 0: Terminal P1 OFF 1: Terminal P1 ON
Multi-Function Photo Coupler 2	Terminal P2 0: Terminal P2 OFF 1: Terminal P2 ON
Output Frequency	Actual Drive Speed Monitored the Drive's output frequency. Unit depends on o1-03. Unit is not affected by Speed Scale SS.
Actual Current	Actual Output Current Monitored the Drive's output current. Unit is 0.01 A for drives set up to 11 kW in Heavy Duty or Normal Duty and 0.1 A for drives set up for 15 kW and above. Unit is not affected by Current Scale CS.

◆ Standard DI/DO Status (Vendor Specific YE Assy) - 157 (0x9D)

Input Instance	Byte	Bit 7	Bit 6	Bit 5	Bit 4	Bit 3	Bit 2	Bit 1	Bit 0	
157	0	FAULT	ALARM	READY	Speed Agree	Reset	REV Running	ZSP	Running	
	1	-	-	-	-	-	Local/Remote	UV	OPE	
	2	-	Multi-Function Input 7	Multi-Function Input 6	Multi-Function Input 5	Multi-Function Input 4	Multi-Function Input 3	Multi-Function Input 2	Multi-Function Input 1	
	3	-	-	Multi-Function Photo Coupler 2	Multi-Function Photo Coupler 1	Multi-Function Digital Output	-	-	-	
	4	Analog Input 1 (Low Byte)								
	5	Analog Input 1 (High Byte)								
	6	Output Frequency (Low Byte)								
	7	Output Frequency (High Byte)								

Parameter	Data
Running	Running 0: Stop 1: Forward or Reverse Running
ZSP	Zero Speed 0: Running 1: Stop or DC Injection Braking
REV Running	Reverse Running 0: Not Reverse Running 1: Reverse Running
Reset	Reset 0: No Reset 1: Reset
Speed Agree	Speed Agree 0: No Speed Agree 1: Actual speed at speed reference

10 Input Assemblies (Drive Produces)

Parameter	Data
READY	Drive Ready 0: Not Ready 1: Ready
ALARM	Drive Alarm 0: No Drive Alarm 1: Alarm
FAULT	Drive Fault 0: No Drive Fault 1: Fault
OPE	OPE Fault 0: No OPExx Fault 1: OPExx
UV	Under Voltage 0: No Under Voltage 1: Under Voltage
Local/Remote	Status of Run command from Network 0: Run command is not from network 1: Run command is from network
Multi-Function Input 1	Terminal S1 0: Terminal S1 OFF 1: Terminal S1 ON
Multi-Function Input 2	Terminal S2 0: Terminal S2 OFF 1: Terminal S2 ON
Multi-Function Input 3	Terminal S3 0: Terminal S3 OFF 1: Terminal S3 ON
Multi-Function Input 4	Terminal S4 0: Terminal S4 OFF 1: Terminal S4 ON
Multi-Function Input 5	Terminal S5 0: Terminal S5 OFF 1: Terminal S5 ON
Multi-Function Input 6	Terminal S6 0: Terminal S6 OFF 1: Terminal S6 ON
Multi-Function Input 7	Terminal S7 0: Terminal S7 OFF 1: Terminal S7 ON
Multi-Function Digital Output	Terminal MA/MB 0: Terminal MA/MB OFF 1: Terminal MA/MB ON
Multi-Function Photo Coupler 1	Terminal P1 0: Terminal P1 OFF 1: Terminal P1 ON
Multi-Function Photo Coupler 2	Terminal P2 0: Terminal P2 OFF 1: Terminal P2 ON
Analog Input 1	Analog Input A1
Output Frequency	Actual Drive Speed Monitored the Drive's output frequency. Unit depends on o1-03. Unit is not affected by Speed Scale SS.

◆ Enhanced Torque Status, Dynamic (Vendor Specific YE Assy) - 158 (0x9E)

Input Instance	Byte	Bit 7	Bit 6	Bit 5	Bit 4	Bit 3	Bit 2	Bit 1	Bit 0
158	0	FAULT	ALARM	READY	Speed Agree	Reset	REV Running	ZSP	Running
	1	Multi-Function Photo Coupler 2	Multi-Function Photo Coupler 1	Multi-Function Digital Output	Local/Remote	Function Code High Bit	Function Code Low Bit	UV	OPE
	2	Actual Torque (Low Byte), not supported							
	3	Actual Torque (High Byte), not supported							
	4	Register Number (Low Byte)							
	5	Register Number (High Byte)							
	6	Register Data (Low Byte)							
	7	Register Data (High Byte)							

Parameter	Data
Running	Running 0: Stop 1: Forward or Reverse Running
ZSP	Zero Speed 0: Running 1: Stop or DC Injection Braking
REV Running	Reverse Running 0: Not Reverse Running 1: Reverse Running
Reset	Reset 0: No Reset 1: Reset
Speed Agree	Speed Agree 0: No Speed Agree 1: Actual speed at speed reference
READY	Drive Ready 0: Not Ready 1: Ready
ALARM	Drive Alarm 0: No Drive Alarm 1: Alarm
FAULT	Drive Fault 0: No Drive Fault 1: Fault
OPE	OPE Fault 0: No OPExx Fault 1: OPExx
UV	Under Voltage 0: No Under Voltage 1: Under Voltage
Local/Remote	Status of Run command from Network 0: Run command is not from network 1: Run command is from network
Multi-Function Digital Output	Terminal MA/MB 0: Terminal MA/MB OFF 1: Terminal MA/MB ON
Multi-Function Photo Coupler 1	Terminal P1 0: Terminal P1 OFF 1: Terminal P1 ON

10 Input Assemblies (Drive Produces)

Parameter	Data
Multi-Function Photo Coupler 2	Terminal P2 0: Terminal P2 OFF 1: Terminal P2 ON
Actual Torque	Output Torque, not supported
Register Number	MEMOBUS/Modbus Register Number
Register Data	MEMOBUS/Modbus Register Data

Note: This is a paired assembly (108/158).

Note: Refer to the MEMOBUS/Modbus Data Table in Appendix C of the V1000 Technical Manual for a list of monitor data using the MEMOBUS/Modbus message area.

Table 20 Reply Mapping - 158

Function Code Bits/ Byte	Write Success	Read Success	Write Failure	Read Failure	Function Code Equal to 0 0
Function Bits (High/Low)	1 1	1 1	0 1	0 1	0 0
4	Output Assembly Register Number (Low Byte)	Output Assembly Register Number (Low Byte)	Output Assembly Register Number (Low Byte)	Output Assembly Register Number (Low Byte)	0
5	Output Assembly Register Number (High Byte)	Output Assembly Register Number (High Byte)	Output Assembly Register Number (High Byte)	Output Assembly Register Number (High Byte)	0
6	0	Read Data (Low Byte)	Error Code	Error Code	0
7	0	Read Data (High Byte)	0	0	0

Table 21 Error Replies - 158

Error Code	Description
0x02	Invalid Register Number
0x21	Upper/Lower Limit Error
0x22	Option generated busy event. The MEMOBUS/Modbus requested operation is in the process loop but the drive is not done yet. Writing "Enter" when drive is running. Attempt to write data that is read only. Attempt to write a constant when drive is running. During a CPF06 event attempting to write to registers other than A1-00 to A1-05, E1-03, o2-04.
0x23	Attempting to write during a drive undervoltage (Uv) event.
0x24	Attempting to write while the drive is storing data.

◆ Change of State Response (Vendor Specific YE Assy) - 199 (0xC7)

Input Instance	Byte	Bit 7	Bit 6	Bit 5	Bit 4	Bit 3	Bit 2	Bit 1	Bit 0	
199	0	Multi-Function Input 4	Multi-Function Input 3	NetCtrl	NetRef	Fault Reset	External Fault	Run Rev	Run Fwd	
	1	–	–	–	–	–	Multi-Function Input 7	Multi-Function Input 6	Multi-Function Input 5	
	2	FAULT	ALARM	READY	Speed Agree	Reset	REV Running	ZSP	Running	
	3	NetCtrl (Status)	NetRef (Status)	–	–	–	2nd Motor	UV	OPE	
	4	Output Frequency (Low Byte)								
	5	Output Frequency (High Byte)								
	6	Actual Torque (Low Byte), not supported								
	7	Actual Torque (High Byte), not supported								

Parameter	Data
Run Fwd	Forward Run command from Network 0: Forward Run command is not from network 1: Forward Run command is from network
Run Rev	Reverse Run command from Network 0: Reverse Run command is not from network 1: Reverse Run command is from network
External Fault	External Fault command from Network 0: External Fault command is not from network 1: External Fault command is from network
Fault Reset	Fault Reset command from Network 0: Fault Reset command is not from network 1: Fault Reset command is from network
NetRef	Reference command from Network 0: Reference command is not from network 1: Reference command is from network
NetCtrl	Run command from Network 0: Run command is not from network 1: Run command is from network
Multi-Function Input 3	Terminal S3 command by Network 0: Terminal S3 command OFF 1: Terminal S3 command ON
Multi-Function Input 4	Terminal S4 command by Network 0: Terminal S4 command OFF 1: Terminal S4 command ON
Multi-Function Input 5	Terminal S5 command by Network 0: Terminal S5 command OFF 1: Terminal S5 command ON
Multi-Function Input 6	Terminal S6 command by Network 0: Terminal S6 command OFF 1: Terminal S6 command ON
Multi-Function Input 7	Terminal S7 command by Network 0: Terminal S7 command OFF 1: Terminal S7 command ON
Running	Running 0: Stop 1: Forward or Reverse Running

10 Input Assemblies (Drive Produces)

Parameter	Data
ZSP	Zero Speed 0: Running 1: Stop or DC Injection Braking
REV Running	Reverse Running 0: Not Reverse Running 1: Reverse Running
Reset	Reset 0: No Reset 1: Reset
Speed Agree	Speed Agree 0: No Speed Agree 1: Actual speed at speed reference
READY	Drive Ready 0: Not Ready 1: Ready
ALARM	Drive Alarm 0: No Drive Alarm 1: Alarm
FAULT	Drive Fault 0: No Drive Fault 1: Fault
OPE	OPE Fault 0: No OPExx fault 1: OPExx
UV	Under Voltage 0: No Under Voltage 1: Under Voltage
2nd Motor	Status of Second Motor 0: First Motor Select 1: Second Motor Select
NetRef (Status)	Status of reference command from Network 0: Reference command is not from network 1: Reference command is from network
NetCtrl (Status)	Status of Run command from Network 0: Run command is not from network 1: Run command is from network
Output Frequency	Actual Drive Speed Monitored the Drive's output frequency. Unit depends on o1-03. Unit is not affected by Speed Scale SS.
Actual Torque	Output Torque, not supported

11 General Class Objects

◆ Identity Object - 1 (Class 0x01)

■ Services Supported

Service Code No. (hex)	Service Name
0E	Get Attribute Single
10	Set Attribute Single
05	Reset

■ Attributes Supported

Instance ID	Attribute	Name	Descriptions	Get	Set	Size	Range	Default
0	1	Object Software Revision	Identity Object software revision	○	–	Word	–	1
1	1	Vendor ID	Manufacturer code. 44 (2C Hex): Yaskawa Electric	○	–	Word	–	44 (YASKAWA)
1	2	Device Type	Device profile. The profile for this product is an AC drive. 2: AC drive	○	–	Word	–	2 (AC Drives)
1	3	Product Code	Product codes determined by the manufacturer.	○	–	Word	–	<>
1	4	Revision	Software revision for the option card.	○	–	Word	–	Depends on software
1	5	Status	Shows the comm. status for the drive.	○	–	Word	–	0
1	6	Serial Number	Option card serial number	○	–	Long	–	Each unit is unique
1	7	Product Name	Product name.	○	–	String (14 Bytes)	–	Product dependant ex) CIMR-VA2A0001
1	8	State	Operation status of the drive. 3: Drive ready 4: Fault	○	–	Byte	–	3
1	9	Configuration Consistency Value	–	○	–	Word	–	0000
1	10	Heartbeat Interval	Heartbeat interval.	○	○	Word	0-10	0=disabled

<1> Product code is 2 bytes. The first byte is the drive type and the second byte is the model number of the drive.

◆ Message Router Object - 2 (Class 0x02)

■ Services Supported

Service Code No. (hex)	Service Name
0E	Get Attribute Single

■ Attributes Supported

Instance ID	Attribute	Name	Descriptions	Get	Set	Size	Range	Default
0	1	Object Software Revision	Shows the Message Router object software revision	○	–	Word	–	1

11 General Class Objects

◆ DeviceNet Object - 3 (Class 0x03)

■ Services Supported

Service Code No. (hex)	Service Name
0E	Get Attribute Single
10	Set Attribute Single
05	Reset

■ Attributes Supported

Instance ID	Attribute	Name	Description	Get	Set	Size	Range	Default (Hex)
0	1	Object Software Revision	DeviceNet object software revision.	O	–	Word	–	2
1	1	MAC ID	Current Value of MAC Address	O	O <1>	Byte	0-63	63
1	2	Baud Rate	Current Value of Baud Rate	O	O <2>	Byte	0-3	00
1	3	Bus Off Interruption (BOI)	Operation at a Bus Off Detection is shown.	O	–	Byte	00-01	00
1	4	Bus Off Counter	The number of Bus Off Detection is shown	O	–	Byte	0-255	00
1	5	Allocation Information	DeviceNet communication connection information.	O	–	Byte x2	–	00, 00
1	6	MAC ID Switch Changed	Indication that MAC Address Switch Changed since last Power-up	O	–	Bool	–	0
1	7	Baud Rate Switch Changed	Indication that Baud Rate Switch Changed since last Power-up	O	–	Bool	–	0
1	8	MAC ID Switch Value	MAC ID setting value. Setting is done through drive operator, F6-50.	O	–	Byte	0-64	–
1	9	Baud Rate Switch Value	Baud rate setting value. Setting is done through drive operator.	O	–	Byte	0-4	–

<1> Set only settable when Attribute 08, F6-50 = 64

<2> Set only valid when Attribute 09, F6-63 = 3.

◆ Assembly Object - 4 (Class 0x04)

■ Services Supported

Service Code No. (hex)	Service Name
0E	Get Attribute Single
10	Set Attribute Single

■ Attributes Supported

Instance ID	Attribute	Name	Descriptions	Get	Set	Size	Range	Default
0	1	Object Software Revision	Show the DeviceNet Object software revision	○	–	Word	–	2
20	3	Data	Same function as the Basic Speed Control (Output Assembly)	○	○	Array 4 bytes	–	00 00 00 00
21	3	Data	Same function as the Extended Speed Control (Output Assembly)	○	○	Array 4 bytes	–	00 00 00 00
22	3	Data	Same function as the Speed and Torque Control (Output Assembly)	○	○	Array 6 Bytes	–	00 00 00 00 00 00
23	3	Data	Same function as the Extended Speed and Torque Control (Output Assembly)	○	○	Array 6 Bytes	–	00 00 00 00 00 00
70	3	Data	Same function as the Basic Speed Control (Input Assembly)	○	–	Array 4 bytes	–	00 00 00 00
71	3	Data	Same function as the Extended Speed Control (Input Assembly)	○	–	Array 4 bytes	–	00 00 00 00
72	3	Data	Same function as the Speed Control (Input Assembly)	○	–	Array 6 bytes	–	00 00 00 00 00 00
73	3	Data	Same function as the Speed and Torque Control (Input Assembly)	○	–	Array 6 bytes	–	00 00 00 00 00 00
100	3	Data	Same function as the MEMOBUS/ Modbus Message Command (Output Assembly)	○	○	Array 5 bytes	–	00 00 00 00 00
101	3	Data	Same function as the Standard Control (Output Assembly)	○	○	Array 8 bytes	–	00 00 00 00 00 00 00 00
102	3	Data	Same function as the Accel/ Decel Time (Output Assembly)	○	○	Array 8 bytes	–	00 00 00 00 00 00 00 00
105	3	Data	Same function as the Enhanced Torque Control, Dynamic (Output Assembly)	○	○	Array 8 bytes	–	00 00 00 00 00 00 00 00
106	3	Data	Same function as the Enhanced Control (Output Assembly)	○	○	Array 8 bytes	–	00 00 00 00 00 00 00 00
107	3	Data	Same function as the Standard DI/ DO Control (Output Assembly)	○	○	Array 8 bytes	–	00 00 00 00 00 00 00 00
108	3	Data	Same function as the Enhanced Torque Control, Dynamic (Output Assembly)	○	○	Array 8 bytes	–	00 00 00 00 00 00 00 00
120	3	Data	Same function as the Speed Command 1 (Output Assembly)	○	○	Array 4 bytes	–	00 00 00 00
121	3	Data	Same function as the Torque Command 1 (Output Assembly)	○	○	Array 4 bytes	–	00 00 00 00
122	3	Data	Same function as the Speed Command 2 (Output Assembly)	○	○	Array 6 bytes	–	00 00 00 00 00 00
123	3	Data	Same function as the Torque Command 2 (Output Assembly)	○	○	Array 6 bytes	–	00 00 00 00 00 00
124	3	Data	Same function as the Speed Dynamic Assy (Output Assembly)	○	○	Array 8 bytes	–	00 00 00 00 00 00 00 00

11 General Class Objects

Instance ID	Attribute	Name	Descriptions	Get	Set	Size	Range	Default
125	3	Data	Same function as the Torque Dynamic Assy (Output Assembly)	○	○	Array 8 bytes	–	00 00 00 00 00 00 00 00
126	3	Data	Same function as the Speed / Torque Assy (Output Assembly)	○	○	Array 8 bytes	–	00 00 00 00 00 00 00 00
130	3	Data	Same function as the Speed Status 1 (Input Assembly)	○	–	Array 4 bytes	–	00 00 00 00
131	3	Data	Same function as the Current Status 1 (Input Assembly)	○	–	Array 4 bytes	–	00 00 00 00
132	3	Data	Same function as the Current & Speed Status 1 (Input Assembly)	○	–	Array 6 bytes	–	00 00 00 00 00 00
134	3	Data	Same function as the Speed Status Dynamic Assy (Input Assembly)	○	–	Array 8 bytes	–	00 00 00 00 00 00 00 00
135	3	Data	Same function as the Current Status Dynamic Assy (Input Assembly)	○	–	Array 8 bytes	–	00 00 00 00 00 00 00 00
136	3	Data	Same function as the Torque and Speed Status (Input Assembly)	○	–	Array 8 bytes	–	00 00 00 00 00 00 00 00
150	3	Data	Same function as the MEMOBUS/ Modbus Message Reply (Input Assembly)	○	–	Array 5 bytes	–	00 00 00 00 00
151	3	Data	Same function as the Standard Status (Input Assembly)	○	–	Array 8 bytes	–	00 00 00 00 00 00 00 00
152	3	Data	Same function as the Standard Status 2 (Input Assembly)	○	–	Array 8 bytes	–	00 00 00 00 00 00 00 00
155	3	Data	Same function as the Enhanced Speed Status (Input Assembly)	○	–	Array 8 bytes	–	00 00 00 00 00 00 00 00
156	3	Data	Same function as the Enhanced Control Status (Input Assembly)	○	–	Array 8 bytes	–	00 00 00 00 00 00 00 00
157	3	Data	Same function as the Standard DI/ DO Status (Input Assembly)	○	–	Array 8 bytes	–	00 00 00 00 00 00 00 00
158	3	Data	Same function as the Enhanced Torque Status, Dynamic (Input Assembly)	○	–	Array 8 bytes	–	00 00 00 00 00 00 00 00
199	3	Data	Same function as the Change of State Response (Input Assembly)	○	–	Array 8 bytes	–	00 00 00 00 00 00 00 00

◆ DeviceNet Connection Object - 5 (Class 0x05)

■ Services Supported

Service Code No. (hex)	Service Name
0E	Get Attribute Single
10	Set Attribute Single

■ Attributes Supported

Instance ID	Attribute	Name	Descriptions	Get	Set	Size	Range	Default
0	1	Object Software Revision	DeviceNet Connection object software revision	○	–	Word	–	1
1 Explicit	1	State	Status of the instance. 00: Network not found or not yet connected. 01: Online, awaiting connection from the master. 02: Waiting to write the connection ID. 03: Connected successfully. 04: Time-out.	○	–	Byte	–	3
	2	Instance type	Shows the instance type. 00: Explicit message 01: I/O message	○	–	Byte	–	0
	3	Transport class trigger	Defines behavior of the connection.	○	–	Byte	–	83h
	4	Produced connection ID	Label used in the comm. header for the drive.	○	–	Word	–	–
	5	Consumed connection ID	Set once the comm. connection is complete.	○	–	Word	–	–
	6	Initial comm characteristics	Code for the comm. type.	○	–	Byte	–	21h
	7	Produced connection size	Maximum number of bytes that can be transmitted.	○	–	Byte	–	–
	8	Consumed connection size	Maximum number of bytes received.	○	–	Byte	–	–
	9	Expected packet rate	The time it takes to time-out after receiving a comm. request. Rounds up to the nearest 10 ms.	○	○	Word	0 ~ 65535	0
	12	Watchdog time-out action	Action taken after timeout. 00: Save value until reset or power is shut off 01: Auto delete 02: Restart while remaining connected	○	–	Byte	–	1
	13	Produced connection path length	Number of bytes for the transmission connection path.	○	–	Word	–	0
	14	Produced connection path	Specifies the application object that will produce data by this Connection Object.	○	–	Array	–	–
	15	Consumed connection path length	Number of bytes in the consumed connection path.	○	–	Word	–	0
	16	Consumed connection path	Specifies the Application Object that will receive data consumed by this Connection Object.	○	–	Array	–	–

11 General Class Objects

Instance ID	Attribute	Name	Descriptions	Get	Set	Size	Range	Default
2 Polled I/O	1	State	Status of the instance. 00: Network not found or not yet connected. 01: Online, awaiting connection from the master. 02: Waiting to write the connection ID. 03: Connected successfully. 04: Timeout.	○	–	Byte	–	3
	2	Instance type	Shows the instance type. 00: Explicit message 01: I/O message	○	–	Byte	–	1
	3	Transport class trigger	Defines behavior of the connection.	○	–	Byte	–	–
	4	Produced connection ID	Label used in the comm. header for the drive.	○	–	Word	–	–
	5	Consumed connection ID	Set once the comm. connection is complete.	○	–	Word	–	–
	6	Initial comm characteristics	Code for the comm. type.	○	–	Byte	–	–
	7	Produced connection size	Maximum number of bytes that can be transmitted.	○	–	Byte	–	4
	8	Consumed connection size	Maximum number of bytes received.	○	–	Byte	–	4
	9	Expected packet rate	The time it takes to time-out after receiving a comm. request. Rounds up to the nearest 10 ms.	○	○	Word <>	0 ~ 65535	0
2 Polled I/O	12	Watchdog time-out action	Action taken after timeout. 00: Save value until reset or power is shut off 01: Auto delete 02: Restart while remaining connected	○	○	Byte	0 ~ 2	0
	13	Produced connection path length	Number of bytes for the transmission connection path.	○	–	Word <>	–	6
	14	Produced connection path	Specifies the application object whose data will be produced by this Connection Object.	○	○	Array <>	–	20h 04h 24h 47h 30h 03h
	15	Consumed connection path length	Number of bytes in the consumed connection path.	○	–	Word <>	–	6
	16	Consumed connection path	Specifies the Application Object that will receive data consumed by this Connection Object.	○	○	Array <>	–	20h 04h 24h 15h 30h 03h
	100	Produced connection path	Number of bytes in the consumed connection path.	○	○	Byte	–	71
	101	Consumed connection path	Specifies the Application Object that will receive data consumed by this Connection Object.	○	○	Byte3	–	21

Instance ID	Attribute	Name	Descriptions	Get	Set	Size	Range	Default
3 COS	1	State	Status of the instance. 00: Network not found or not yet connected. 01: Online, awaiting connection from the master. 02: Waiting to write the connection ID. 03: Connected successfully. 04: Timeout.	○	–	Byte	–	1
	2	Instance type	The instance type. 00: Explicit message 01: I/O message	○	–	Byte	–	1
	3	Transport class trigger	Defines behavior of the connection.	○	–	Byte	–	0x10
	4	Produced connection ID	Label used in the comm. header for the drive. Set once the comm. connection is complete.	○	–	Word	–	-
	5	Consumed connection ID		○	–	Word	–	0xFFFF
	6	Initial comm characteristics	Code for the comm. type.	○	–	Byte	–	0x0F
	7	Produced connection size	Maximum number of bytes that can be transmitted.	○	–	Byte	–	8
	8	Consumed connection size	Maximum number of bytes received.	○	–	Byte	–	0
	9	Expected packet rate	The time it takes to time-out after receiving a comm. request. Rounds up to the nearest 10 ms.	○	○	Word	–	0
	12	Watchdog time-out action	Action taken after timeout. 00: Save value until reset or power is shut off 01: Auto delete 02: Restart while remaining connected	○	○	Byte	–	0
	13	Produced connection path length	Number of bytes for the transmission connection path.	○	–	Word <I>	–	6
	14	Produced connection path	Specifies the application object whose data will be produced by this Connection Object.	○	–	Array <I>	–	20h 04h 24h C7h 30h 03h
	15	Consumed connection path length	Number of bytes in the consumed connection path.	○	–	0	–	0
	16	Consumed connection path	Specifies the Application Object that will receive data consumed by this Connection Object.	○	–	Array <I>	–	0
	17	Production inhibit time	–	○	○	Word	–	0

<1> These attributes default on power-up to Logical encoding. If a message is received that is in Symbolic encoding, a three-byte Symbolic encoded message is returned.

<2> A polled EPR time. Timing out will cause the drive to fault with a “bUS” fault.

11 General Class Objects

◆ Motor Data Object - 40 (Class 0x28)

■ Services Supported

Service Code No. (hex)	Service Name
0E	Get Attribute Single
10	Set Attribute Single

■ Attributes Supported

Instance ID	Attribute	Name	Descriptions	Get	Set	Size	Range	Default
0	1	Object Software Revision	Motor Data Object software revision	○	–	Word	–	1
1	3	Motor Type	Differs by the motor control mode that is selected. When set for Open Loop Vector for PM motors (A1-02 = 5), value becomes 3 (PM motor). When the drive is set for V/f Control (A1-02 = 0) or Open Loop Vector (A1-02 = 2), value becomes 7 (squirrel cage motor).	○	–	Byte	–	Depends on A1-02, Control Method Selection
1	6	Rated Current [0.1 A]	Motor rated current. Displayed in 0.1 A units. Changes according to the current scale (CS).	○	○	Byte		Depends on Capacity
1	7	Rated Voltage [1 V]	Motor rated voltage. Displayed in 1 V units. Changes according to the voltage scale (VS).	○	○	Byte		Depends on Capacity

■ Corresponding Data on V1000 MEMOBUS/Modbus

Instance ID	Attribute	Description	Data
1	3	Motor Type	The value of this parameter is dependent of the value of A1-02, Control Method Selection. If A1-02 is equal to “5”, PM Open Loop Vector (PM), set this parameter to “3”, Permanent Magnet Motor. Else, set this parameter to “7”, Induction Motor.
1	6	Rated Current [0.1 A]	Motor Rated Current The unit of value returned is 0.1[A]. Uses current scale.
1	7	Rated Voltage [1 V]	Uses voltage scale.

◆ Control Supervisor Object - 41 (Class 0x29)

■ Services Supported

Service Code No. (hex)	Service Name
0E	Get Attribute Single
10	Set Attribute Single
05	Reset

■ Attributes Supported

Instance ID	Attribute	Name	Descriptions	Get	Set	Size	Range	Default
0	1	Object Software Revision	Revision number of the Control Supervisor Object.	○	–	Word	–	1
1	3	Run 1 (Forward Run Command)	Forward Running 0: Stop 1: Forward Running	○	○	Byte	0,1	0
1	4	Run 2 (Reverse Run Command)	Reverse Running 0: Stop 1: Reverse Running	○	○	Byte	0,1	0
1	5	NetCtrl (Command)	Run command from Network 0: Depends on b1-02 1: Enables the run command from network	○	○	Byte	0,1	0
1	6	State	Drive status. 2: Not ready 3: Ready (stopped) 4: Enabled (Run command present) 5: Deceleration to stop 6: Fault stop 7: Fault	○	–	Byte	–	3
1	7	Running 1 (FWD)	Forward Running 0: Stop 1: Forward Running	○	–	Byte	–	0
1	8	Running 1 (REV)	Reverse Running 0: Stop 1: Reverse Running	○	–	Byte	–	0
1	9	Ready	Drive Ready 0: Not ready 1: Ready	○	–	Byte	–	1
1	10	Fault	Drive Fault 0: No Drive Fault 1: Fault	○	–	Byte	–	0
1	11	Warning	Warning 0: No Warning 1: Warning	○	–	Byte	–	0
1	12	Fault Reset	Fault Reset 0: No Fault Reset 1: Fault Reset	○	○	Byte	0,1	0
1	13	Fault Code	Current Fault Refer to DeviceNet Fault Code Conversion Table on page 81 for details	○	–	Word	–	0000
1	15	Control from Net (Status)	Run Command from DeviceNet 0: Enables the run command from except for DeviceNet 1: Enables the run command from DeviceNet	○	–	Byte	–	0
1	16	DeviceNet Fault Mode	Normal 2 (vendor specific)	○	–	Byte	–	2

11 General Class Objects

Instance ID	Attribute	Name	Descriptions	Get	Set	Size	Range	Default
1	17	Force Fault	External fault 0: No External fault 1: External fault (EF0) Triggered by the rising edge of the signal	○	○	Byte	0,1	0
1	18	Force Reset	External fault status 0: No External fault 1: External fault Triggered by the rising edge of the signal.	○	-	Byte	-	0

■ Corresponding Data on V1000 MEMOBUS/Modbus (Control Supervisor Object)

Instance ID	Attribute	Description	Data
1	3	Run 1	Forward Run Command
1	4	Run 2	Reverse Run Command
1	5	NetCtrl (Command)	Net Control Command
1	6	State	Drive Status 2 = Not ready (complement of Ready) 3 = Ready, Drive Ready 4 = Enable 5 = Stopping 6 = Stopping due to fault 7 = Faulted
1	7	Running 1	Forward Running
1	8	Running 2	Reverse Running
1	9	Ready	Drive Ready
1	10	Faulted	Drive Fault
1	11	Warning	Drive Alarm
1	12	Fault Reset	Fault Reset
1	13	Fault Code	Current Fault
1	15	Control from Net (Status)	Status of Run command source (1 = Network) 0 = As set by b1-02 1 = Network
1	16	DeviceNet Fault Mode	Always set to "2" (Vendor specific)
1	17	Force Fault	External Fault, 0 -> 1
1	18	Force Reset	0 -> 1

■ DeviceNet Fault Code Conversion Table

V1000 Fault Code [Dec] (MEMOBUS/Modbus #0080hex)	DeviceNet Fault Code [hex]	Description
0	0000	None
2	3220	DC Bus Undervolt (Uv1)
3	5110	CTL PS Undervolt (Uv2)
4	3222	MC Answerback (Uv3)
6	2120	Ground Fault (GF)
7	2300	Over Current (oC)
8	3210	DC Bus Overvolt (ov)
9	4200	Heatsink Overtemp (oH)
10	4210	Heatsink Max Temp (oH1)
11	2220	Motor Overload (oL1)
12	2200	Inv Overload (oL2)
13	2221	Overtorque Det 1 (oL3)
14	2222	Overtorque Det 2 (oL4)
15	7110	DynBrk Transistor (rr)
16	7112	DynBrk Resistor (rH)
17	9000	External Fault 3 (EF3)
18	9000	External Fault 4 (EF4)
19	9000	External Fault 5 (EF5)
20	9000	External Fault 6 (EF6)
21	9000	External Fault 7 (EF7)
24	7310	Overspeed Det (oS)
25	7310	Speed Deviation (dEv)
26	7301	PG Open (PGo)
27	3130	Input Phase Loss (PF)
28	3130	Output Phase Loss (LF)
30	5300	Operator Disconnected (oPr)
31	6320	EEPROM R/W Error (Err)
33	7500	MEMOBUS/Modbus Com Fault (CE)
34	7500	DeviceNet communication Error (bUS)
37	8321	Out of Control (CF)
39	9000	External Fault 0 (EF0)

11 General Class Objects

◆ AC/DC Drive Object - 42 (Class 0x2A)

■ Services Supported

Service Code No. (hex)	Service Name
0E	Get Attribute Single
10	Set Attribute Single

■ Attributes Supported

Instance ID	Attribute	Name	Descriptions	Get	Set	Size	Range	Default
0	1	Object Software Revision	Revision number of AC/DC Drive object	○	–	Word	–	1
1	3	Speed Agree	Speed Agree 0: – 1: Speed Agree	○	–	Byte	–	0
1	4	NetRef (Command)	Status of reference command from DeviceNet 0: Reference command from DeviceNet 1: Reference command from except for DeviceNet	○	–	Byte	–	0
1	6	Drive Mode	Drive control mode. 0: Open Loop Vector for PM motors 1: V/f Control 2: Open Loop Vector	○	○	Byte	0 ~ 2	0
1	7	Speed Actual	Actual drive speed Unit is not affected by Speed Scale SS.	○	–	Word	–	3
1	8	Speed Reference	Frequency Reference Monitored the Drive's frequency reference Unit is not affected by Speed Scale SS.	○	○	Word	–	0
1	9	Current Actual	Actual Output Current Unit is 0.01 A for drives set up to 11 kW in Heavy Duty or Normal Duty and 0.1 A for drives set up for 15 kW and above. Unit is not affected by Current Scale CS.	○	–	Word	–	0
1	11	Torque Actual	Not supported	○	–	Word	–	0
1	12	Torque Reference	Not supported	○	○	Word	–	0
1	15	Power Actual [W]	Drive Output Power Unit is affected by Power Scale PS	○	–	Word	–	0
1	16	Input Voltage [V]	Drive Input Voltage Unit is affected by Voltage Scale VS	○	–	Word	–	Depends on Capacity
1	17	Output Voltage [V]	Drive Output Voltage Unit is affected by Voltage Scale VS	○	–	Word	–	0
1	18	Accel Time [ms]	Acceleration Time 1 (C1-01) Units set in parameter C1-10. Unit is affected by Time scale (TS).	○	○	Word	–	2710h
1	19	Decel Time [ms]	Deceleration Time 1 (C1-02) Units set in parameter C1-10. Unit is affected by Time scale (TS).	○	○	Word	–	2710h
1	20	Low Speed Limit Percent of Max Speed	Frequency Reference Lower Limit (d2-02)	○	○	Word	0 ~ 1100	0
1	21	High Speed Limit Percent of Max Speed	Frequency Reference Upper Limit(d2-01)	○	○	Word	0 ~ 1100	3E8h
1	22	Speed Scale (–15 to 15)	Reference and setting for F6-56, scale of units for speed-related data	○	○	Byte	–15 ~ 15	0
1	23	Current Scale (–15 to 15)	Reference and setting for F6-57, scale of units for current-related data	○	○	Byte	–15 ~ 15	0

Instance ID	Attribute	Name	Descriptions	Get	Set	Size	Range	Default
1	24	Torque Scale (-15 to 15)	Reference and setting for F6-58, scale of units for torque-related data	○	○	Byte	-15 ~ 15	0
1	26	Power Scale (-15 to 15)	Reference and setting for F6-59, scale of units for power-related data	○	○	Byte	-15 ~ 15	0
1	27	Voltage Scale (-15 to 15)	Reference and setting for F6-60, scale of units for voltage-related data	○	○	Byte	-15 ~ 15	0
1	28	Time Scale (-15 to 15)	Reference and setting for F6-61, scale of units for speed-related data	○	○	Byte	-15 ~ 15	0
1	29	Reference from Net (Status)	Status of reference command from DeviceNet 0: Reference command from DeviceNet 1: Reference command from except for DeviceNet	○	-	Byte	-	0

■ Corresponding Data on V1000 MEMOBUS/Modbus (AC/DC Drive Object)

Instance ID	Attribute	Description	Data
1	3	At Reference	Speed Agree
1	4	Net Reference (Command)	Net Reference Command
1	6	Drive Mode	Sets the Control Method
1	7	Speed Actual [RPM]	Speed Feedback or Output frequency
1	8	Speed Reference [RPM]	Speed Command
1	9	Current Actual [0.01A]	Output Current
1	10	Current Limit	Not Supported
1	11	Torque Actual	Not Supported
1	12	Torque Reference	Not Supported
1	15	Power Actual [W]	Monitor Parameter U1-08
1	16	Input Voltage [V]	Parameter E1-01
1	17	Output Voltage [V]	Monitor Parameter U1-06
1	18	Accel Time [ms]	Parameter C1-01
1	19	Decel Time [ms]	Parameter C1-02
1	20	Low Speed Limit Percent of Max Speed	Parameter d2-02
1	21	High Speed Limit Percent of Max Speed	Parameter d2-01
1	22	Speed Scale (-15 to 15)	Parameter F6-56
1	23	Current Scale (-15 to 15)	Parameter F6-57
1	24	Torque Scale (-15 to 15)	Parameter F6-58
1	26	Power Scale (-15 to 15)	Parameter F6-59
1	27	Voltage Scale (-15 to 15)	Parameter F6-60
1	28	Time Scale (-15 to 15)	Parameter F6-61
1	29	Reference from the Net (Status)	Status of reference command (1 = Network) 0 = As set by bl-01, 1 = Network

12 Vendor-Specific (Yaskawa) Class Objects

◆ Yaskawa Drive Parameters Object - 100 (Class 0x64)

■ Services Supported

Service Code No. (hex)	Service Name
0E	Get Attribute Single
10	Set Attribute Single

This is a dynamic explicit Class Object. With this Class object any drive parameter with a MEMOBUS/Modbus address greater than 0x00FF can be accessed. The mapping of Class Object instance / attribute to MEMOBUS/Modbus address is as follows.

Given a typical MEMOBUS/Modbus Address of 0xXXYY

The DeviceNet Instance value is equal to XX

The DeviceNet Attribute value is equal to YY

As an example, to access parameter b5-12 (MEMOBUS/Modbus Address =0x01B0)

Class Object is 100 (0x64) (Always for this Class Object)

Instance = 0x01, Attribute = 0xB0

Note: Writing a zero to 0x0900 (Enter) stores changed parameters to the drive non-volatile memory. Writing a zero to 0x0910 (Accept) allows the drive to use the changed parameters. This normally is automatically sent when the parameter is changed. Read Enter Command 0x0900 or Accept Command 910 will always return a value of 0x0001.

■ Attributes Supported

Instance ID	Attribute	Name	Descriptions	Get	Set	Size	Range	Default
0	1	Object Software Revision	Yaskawa Drive Parameters object software revision	○	–	Word	–	1
1	00	MEMOBUS/Modbus Register 0x0100	Language selection	○	○	Word	0 ~ 7	1
1	01	MEMOBUS/Modbus Register 0x0101	Parameter access level	○	○	Word	0 ~ 2	2
1	YY	MEMOBUS/Modbus Registers 0x0100 ~ 0x01FF	MEMOBUS/Modbus registers 0x0100 to 0x01FF	○	○	Word	–	–
2 thru 255	YY	MEMOBUS/Modbus Registers 0x0200 ~ 0x02FF	MEMOBUS/Modbus registers 0x0200 to 0x02FF	○	○	Word	–	–
	–	–	–	○	○	Word	–	–
	YY	MEMOBUS/Modbus Register 0xFF00 ~ 0xFFFF	MEMOBUS registers 0xFF00 to 0xFFFF	○	○	Word	–	–

Note: Attempting to set a read-only parameter results in a DeviceNet error code of 0x0E, Attribute Not Settable.

Note: Attempting to access an invalid parameter results in a DeviceNet error code of 0x09, Invalid Attribute Value

Note: Refer to the MEMOBUS/Modbus Data Table in Appendix C of the V1000 Technical Manual for a list of monitor data using the MEMOBUS/Modbus message area.

◆ Yaskawa Monitor/Control Object - 125 (Class 0x7D)

■ Services Supported

Service Code No. (hex)	Service Name
0E	Get Attribute Single
10	Set Attribute Single

This is a dynamic explicit Class Object. With this Class object any parameter with a MEMOBUS/Modbus address less than 0x0100 can be accessed. This class is similar to the Drive Parameters Object Class 100, except that since the most significant byte of MEMOBUS/Modbus address is always zero, the instance in this class remains at "1".

Given a typical MEMOBUS/Modbus Address of 0x00YY

The DeviceNet Instance value is equal to 0x01

The DeviceNet Attribute value is equal to YY

As an example, to access Drive Status (MEMOBUS/Modbus Address = 0x002C)

Class Object is 125 (0x7D) (Always for this Class Object)

Instance = 0x01

Attribute = 0x2C

■ Attributes Supported

Instance ID	Attribute	MEMOBUS/Modbus Address	Description	Get	Set	Size
0	1	-	Object Software Revision	O	-	Word
1	1	0x0001	Drive Command Bits	O	O	Word
1	2	0x0002	Frequency Instruction	O	O	Word
-	thru	-	-	O	O	Word
1	255	0x00FF	Unused	O	O	Word

Note: Attempting to set a read-only parameter results in a DeviceNet error code of 0x0E, Attribute Not Settable.

Note: Attempting to access an invalid parameter results in a DeviceNet error code of 0x09, Invalid Attribute Value

Note: Refer to the MEMOBUS/Modbus Data Table in Appendix C of the V1000 Technical Manual for a list of monitor data using the MEMOBUS/Modbus message area.

13 Troubleshooting

◆ Drive-Side Error Codes

Drive-side error codes appear on the drive's LED operator. Causes of the errors and corrective actions are listed in [Table 22](#).

For additional error codes that may appear on the LED operator screen, refer to the technical manual for the drive.

■ Faults

Both bUS (DeviceNet Option Communication Error) and EF0 (External Fault Input from the DeviceNet Option) can appear as an alarm or as a fault. When a fault occurs, the digital operator ALM LED remains. When an alarm occurs, the digital operator ALM LED flashes.

If communication stops while the drive is running, answer the following questions to help remedy the fault:

- Is the DeviceNet Option properly installed?
- Is the communication line properly connected to the DeviceNet Option? Is it loose?
- Is the controller program working? Has the controller CPU stopped?
- Did a momentary power loss interrupt communications?

Table 22 Fault Display and Possible Solutions

LED Operator Display		Fault Name
<i>bUS</i>	bUS	DeviceNet Option Communication Error After establishing initial communication, the connection was lost. Only detected when the run command frequency reference is assigned to the option (bl-01=3 or bl-02=3).
Cause		Possible Solution
Master controller (PLC) has stopped communicating.		Check for faulty wiring. Correct any wiring problems.
Communication cable is not connected properly.		
A data error occurred due to noise.		Check the various options available to minimize the effects of noise. Take steps to counteract noise in the control circuit wiring, main circuit lines, and ground wiring. If a magnetic contactor is identified as a source of noise, install a surge absorber to the contactor coil. Make sure the cable used fulfills the DeviceNet requirements. Ground the shield on the controller side and on the DeviceNet Option side.
DeviceNet Option is damaged.		If there are no problems with the wiring and the error continues to occur, replace the DeviceNet Option.
Network power loss		The power on the DeviceNet network cable is 0. Verify power is available between option terminals V+ (red) and V- (black).
Connection time-out		The DeviceNet option Expected Packet Rate (EPR) timer timed out. Make sure that EPR time is set properly.
Duplicate MAC ID		The DeviceNet option MAC ID and at least one other mode have the same MAC ID. Verify F6-50 is set properly.

LED Operator Display		Fault Name
<i>EF0</i>	EF0	External Fault Input from DeviceNet Option The alarm function for an external device has been triggered.
Cause		Corrective Action
An external fault is being sent from the upper controller (PLC).		Remove the cause of the external fault. Reset the external fault input from the PLC device.
Problem with the PLC program.		Check the program used by the PLC and make the appropriate corrections.

LED Operator Display		Fault Name
oFA00	oFA00	DeviceNet Option Fault
		DeviceNet Option is not properly connected.
Cause		Possible Solution
Non-compatible option connected to the drive.		Connect an option that is compatible with the drive.

LED Operator Display		Fault Name
oFA01	oFA01	DeviceNet Option Fault
		DeviceNet Option is not properly connected.
Cause		Possible Solution
Problem with the connectors between the drive and DeviceNet Option.		Turn the power off and check the connectors between the drive and DeviceNet Option.

LED Operator Display		Fault Name
oFA03	oFA03	DeviceNet Option Fault
		DeviceNet Option self-diagnostics error.
Cause		Possible Solution
DeviceNet Option hardware fault.		Replace the DeviceNet Option.

LED Operator Display		Fault Name
oFA04	oFA04	DeviceNet Option Fault
		DeviceNet Option Flash write mode
Cause		Possible Solution
DeviceNet Option hardware fault.		Replace the DeviceNet Option.

LED Operator Display		Fault Name
oFA30 to oFA43	oFA30 to oFA43	DeviceNet Option Fault (port A)
		Communication ID error
Cause		Possible Solution
CC-Link Option hardware fault		⇒ Replace the DeviceNet Option. Contact Yaskawa for assistance.

■ Minor Faults and Alarms

LED Operator Display		Fault Name	
CALL	CALL	Serial Communication Transmission Error	
		Communication has not yet been established.	
Cause		Possible Solution	Minor Fault (H2-□□ = 10)
Communication wiring or terminal resistor connection is faulty, there is a short circuit, or something is not connected properly.		Check for wiring errors. ⇒ Correct the wiring. ⇒ Remove and ground shorts and reconnect loose wires.	Yes
Programming error on the master side		⇒ Check communications at start-up and correct programming errors.	
Communication circuitry is damaged.		Perform a self-diagnostics check. ⇒ Replace the drive if the fault continues to occur.	

◆ Explicit Message Communications Errors

When there is a problem with a request message sent from the master in explicit communications, the drive will return a response message with 94 as the service code well as one of the following error codes as the data.

13 Troubleshooting

Error Code	Description	Cause	Possible Solution
08FF	Service not supported	The service code is incorrect.	Correct the service code.
09FF	Invalid attribute value	The attribute is incorrect.	Correct the attribute.
0CFF	Object state conflict	Attempted to change an drive constant that cannot be changed while the drive is running.	Stop the drive.
0EFF	Attribute not settable	Attempted to change a read-only attribute.	Correct the service code or attribute setting.
13FF	Not enough data	The data size is incorrect.	Correct the data size.
14FF	Attribute not supported	Attempted to execute a service that is not defined for the attribute.	Correct the service code or attribute setting.
15FF	Too much data	The data size is incorrect.	Correct the data size.
16FF	Object does not exist	An unsupported object was specified.	Correct the class or instance setting.
1FFF	Vendor specific error	Attempted to change an Inverter constant that cannot be changed while the drive is running. Attempted to change an drive constant to a value outside of the setting range.	Stop the drive. Specify a value that is within the setting range.
20FF	Invalid parameter	Attempted to change to a data value outside of the setting range.	Specify a data value that is within the setting range.

Note: Refer to the MEMOBUS/Modbus Data Table in Appendix C of the V1000 Technical Manual for a list of monitor data using the MEMOBUS/Modbus message area.

◆ DeviceNet Option Error Codes

Table 23 DeviceNet Option Error Codes

Drive Error Code (hex) <1>	DeviceNet Error Code (hex)	Description	Corrective Action
00	0000	None	-
01	5120	DC Bus Fuse Open (PUF)	Output Transistor Failure – Replace the drive
02	3220	DC Bus Undervolt (UV1)	Input power fluctuation too large
03	5110	CTL PS Undervolt (UV2)	Cycle drive power – Replace drive if fault continues
04	3222	MC Answerback (UV3)	Cycle drive power – Replace drive if fault continues
05	2130	Short Circuit (SC)	Check drive wiring Cycle drive power – Replace drive if fault continues.
06	2120	Ground Fault (GF)	Check for motor and/or cable damage
07	2300	Over Current (OC)	Check motor, motor load and acc/dec rates
08	3210	DC Bus Overvolt (OV)	Check incoming voltage Check deceleration time
09	4200	Heatsink Overtemp (OH)	Check ambient temperature Check drive cooling fan
0A	4210	Heatsink Max Temp (OH1)	Check drive cooling fan
0B	2220	Motor Overload (OL1)	Check the load, acc/dec and cycle times Check motor rated current (E2-01)
0C	2200	Inv Overload (OL2)	Check the load, acc/dec and cycle times Check drive rating
0D	2221	Overtorque Det 1 (OL3)	Check L6-02 and L6-03 settings Check system mechanics
0E	2222	Overtorque Det 2 (OL4)	Check L6-05 and L6-06 settings Check system mechanics
0F	7110	DynBrk Transistor (RR)	Cycle drive power – Replace drive if fault continues
10	7112	DynBrk Resistor (RH)	Check load, operating speed and deceleration time
11	9000	External Fault 3 (EF3)	Multifunction digital input set to external fault Circuit at terminal is closed
12	9000	External Fault 4 (EF4)	
13	9000	External Fault 5 (EF5)	
14	9000	External Fault 6 (EF6)	
15	9000	External Fault 7 (EF7)	
16	9000	External Fault 8 (EF8)	
17	4140	Heatsink Fan (FAN)	Check drive cooling fan
18	7310	Overspeed Det (OS)	Check reference and reference gain Check F1-08 and F1-09 settings
19	7310	Speed Deviation (DEV)	Check load, acc/dec times and system mechanics Check F1-10 and F1-11 settings
1A	7301	PG Open (PGO)	Check PG card connections
1B	3130	Input Phase Loss (PF)	Excessive input voltage fluctuation
1C	3130	Output Phase Loss (LF)	Check for broken wire/loose terminals Check motor rating
1D	5210	None	-
1E	5300	Operator Disconnected (OPR)	Reconnect the digital operator
1F	6320	EEPROM R/W Error (ERR)	Cycle drive power – Replace drive if fault continues
20	0000	None	
21	7500	DeviceNet Comm Error (BUS)	Check DeviceNet network cable connections. Check 24VDC power supply voltage.
22			Check DeviceNet Option Card installation and connections.
23			Cycle drive power – Replace DeviceNet Option or drive if fault continues.
24			

13 Troubleshooting

Drive Error Code (hex) <1>	DeviceNet Error Code (hex)	Description	Corrective Action
25	8321	Out of Control (CF)	Check motor parameters Auto-tune
27	9000	External Fault 0 (EF0)	Check PLC program Check MI switch setting Check DeviceNet Option Card LEDs for fault indication

<1> Drive error code is stored in MEMOBUS/Modbus address 0080 hex.

■ DeviceNet Option Fault Monitors U6-98 and U6-99

The DeviceNet Option SI-N3/V can declare the error/warning conditions via drive monitor parameters as shown in .

Table 24 DeviceNet Option Fault Monitor Descriptions

Fault Condition	Fault Declared	Status Value (U6-99/ U6-98)	Description
No Fault	n/a	0	No faults.
CPU Error	EF0	1	Option board failure.
PLC in Idle State	EF0	2	PLC is sending polled I/O with all data set to zero.
Force Fault	EF0	3	Network sent a message to force this node to the fault state.
Network Power Loss	BUS ERROR	1000	Power on DeviceNet network is off.
Connection Time-out	BUS ERROR	1001	This nodes timer (Expect Packet Rate) timed out.
Dup MAC ID	BUS ERROR	1002	This node and at least one other node have the same MAC ID. Another node sent it's MAC ID to the network first.
Bus-Off	BUS ERROR	1003	CAN transceiver senses network error.

Two drive monitor parameters, U6-99 (OPTN ACTIVE STAT) and U6-98 (OPTN LATCH STAT) assist the user in network troubleshooting.

- U6-99 displays the present DeviceNet Option SI-N3/V status.
- U6-98 displays the first declared fault since the last fault reset or power cycle.

These parameters are accessible from the DeviceNet network the or the drive digital operator. A drive fault reset or power off clears and refreshes both U6-99 and U6-98.

Note: In the event of a PLC idle state, the action taken by the DeviceNet Option SI-N3/V is dependent on the value of parameter F6-54 (Idle Mode Fault Detection).

◆ Automatic Device Replacement (ADR)

This DeviceNet Interface is compatible with the ADR feature associated with Rockwell controllers and DeviceNet Scanners. ADR features Configuration Recovery and Auto Address Recovery.

Note: Drive software version ≥ 1013 is necessary to support the ADR functionality

■ Configuration Recovery (CR)

CR is the scanner's ability to download previously uploaded and saved configuration data to the DeviceNet node.

When a DeviceNet node is removed and returned to the network or replaced with another device, an ADR-enabled scanner reads the device's Electronic Key that is configured in the scanner. A typical setup of the Electronic Key is: Vendor Id, Product Code, Model Number and Product Revision. When the CR feature is enabled, the stored configuration is downloaded to the DeviceNet node.

If the scanner reads the Configuration Consistency Value (CCV), it will use this value to determine if a download will occur. If the CCV in the scanner does not equal the CCV in the DeviceNet node, the configuration information saved in the scanner will be downloaded to the DeviceNet node. In this implementation of DeviceNet, the CCV will always be 0.

■ Auto Address Recovery (AAR)

AAR is the ability of the scanner to change the MAC ID of a node to a predetermined MAC ID. To use this feature the DeviceNet node must have its MAC ID switch (F6-50) set to 64 and its actual MAC ID (F6-63) equal to 63.

If the recovering node is a replacement for another device, putting the new device on the network enables the AAR feature. A scanner with AAR enabled will search the network for a node with a MAC ID of 63 and then read its Electronic Key. If the Electronic Key matches the node being replaced, the scanner will change the found device's MAC ID to the MAC ID of the device it is replacing.

After the device's MAC ID is changed the device sends its duplicate MAC IDs and executes the CR feature. Example: With current Rockwell PLCs, the AAR feature can only be enabled if the CR feature is also enabled.

14 Specifications

◆ Specifications

Table 25 Option Specifications

Model	SI-N3/V (PCB model: SI-N3)
SI-N3/V Supported Messages	<ul style="list-style-type: none"> • Group 2 Server (UCMM capable) • Explicit Messages: Fragmentation is supported. Up to 32 bytes can be input and output. • Polled I/O Messages: Fragmentation is not supported. Up to 8 bytes can be input and output. • Faulted Node Recovery / Offline Connection Set Messages / Automatic Device Replacement (ADR) • Change of State Message (COS). <p>Note: COS can be used as an I/O Input Assembly.</p>
I/O Assembly Instance	Input: 17 types (4~8 bytes) Output: 18 types (4~8 bytes)
DeviceNet Specification	Conformance Level 19: Passed
DeviceNet Profile	AC Drive
Input Power	Voltage: 11~25 Vdc Current: 40 mA
Connector Type	5-pin open-style screw connector
Physical Layer Type	Isolated Physical Layer CAN transceiver + photocoupler
MAC ID Setting	Programmable from drive keypad or network: MAC ID 0 to 63
Communications Speed/Baud Rate	Programmable from drive keypad or network: 125/250/500 kbps <ul style="list-style-type: none"> • Auto Baud Rate • Idle Mode Detect • Heartbeat
Ambient Temperature	-10 °C to +50 °C
Humidity	up to 95% RH (no condensation)
Storage Temperature	-20 °C to +60 °C (allowed for short-term transport of the product)
Area of Use	Indoor (free of corrosive gas, airborne particles, etc.)
Altitude	up to 1000 m

◆ Revision History

The revision dates and the numbers of the revised manuals appear on the bottom of the back cover.

MANUAL NO. TOBP C730600 28A

Published in Japan April 2008 08-4

Date of publication
Date of original publication

Date of Publication	Revision Number	Section	Revised Content
April 2008	—	—	First edition

YASKAWA AC Drive-V1000 Option

DeviceNet

Technical Manual

IRUMA BUSINESS CENTER (SOLUTION CENTER)

480, Kamifujisawa, Iruma, Saitama 358-8555, Japan
Phone 81-4-2962-5696 Fax 81-4-2962-6138

YASKAWA ELECTRIC AMERICA, INC.

2121 Norman Drive South, Waukegan, IL 60085, U.S.A.
Phone 1-847-887-7000 or (800) YASKAWA (927-5292), Fax 1-847-887-7370

YASKAWA ELÉTRICO DO BRASIL LTDA.

Avenida Fagundes Filho, 620 São Paulo-SP CEP 04304-000, Brazil
Phone 55-11-3585-1100 Fax 55-11-5581-8795

YASKAWA ELECTRIC EUROPE GmbH

Hauptstraße 185, 65760 Eschborn, Germany
Phone: 49-6196-569-300 Fax: 49-6196-569-398

YASKAWA ELECTRIC UK LTD.

1 Hunt Hill Orchardton Woods Cumbernauld, G68 9LF, United Kingdom
Phone 44-1236-735000 Fax 44-1236-458182

YASKAWA ELECTRIC KOREA CORPORATION

7F, Doore Bldg. 24, Yeoido-dong, Youngdungpo-Ku, Seoul 150-877, Korea
Phone 82-2-784-7844 Fax 82-2-784-8495

YASKAWA ELECTRIC (SINGAPORE) PTE. LTD.

151 Lorong Chuan, #04-01, New Tech Park 556741, Singapore
Phone 65-6282-3003 Fax 65-6289-3003

YASKAWA ELECTRIC (SHANGHAI) CO., LTD.

No.18 Xizang Zhong Road, Room 1702-1707, Harbour Ring Plaza Shanghai 200001, China
Phone 86-21-5385-2200 Fax 86-21-5385-3299

YASKAWA ELECTRIC (SHANGHAI) CO., LTD. BEIJING OFFICE

Room 1011A, Tower W3 Oriental Plaza, No.1 East Chang An Ave.,
Dong Cheng District, Beijing 100738, China
Phone 86-10-8518-4086 Fax 86-10-8518-4082

YASKAWA ELECTRIC TAIWAN CORPORATION

9F, 16, Nanking E. Rd., Sec. 3, Taipei, Taiwan
Phone 886-2-2502-5003 Fax 886-2-2505-1280



YASKAWA

YASKAWA ELECTRIC CORPORATION

In the event that the end user of this product is to be the military and said product is to be employed in any weapons systems or the manufacture thereof, the export will fall under the relevant regulations as stipulated in the Foreign Exchange and Foreign Trade Regulations. Therefore, be sure to follow all procedures and submit all relevant documentation according to any and all rules, regulations and laws that may apply.

Specifications are subject to change without notice for ongoing product modifications and improvements.

© 2008 YASKAWA ELECTRIC CORPORATION. All rights reserved.

MANUAL NO. SIEP C730600 28A

Published in U.S.A April 2008 08-4
07-11-2